



## **LIFECON DELIVERABLE D2.3**

### **METHODS FOR OPTIMISATION AND DECISION MAKING IN LIFETIME MANAGEMENT OF STRUCTURES**

**Jérôme Lair, CSTB**  
**Tommi Rissanen, VTT**  
**Asko Sarja, VTT**

#### **Shared-cost RTD project**

Project acronym: **LIFECON**

Project full title: **Life Cycle Management of Concrete Infrastructures for Improved Sustainability**

Project Duration: 01.01.2001 - 31.12.2003

Co-ordinator: Technical Research Centre of Finland (VTT)  
VTT Building Technology  
Professor, Dr. Asko Sarja

Date of issue of the report : 03.02.2004



Project funded by the European Community under the  
Competitive and Sustainable Growth Programme  
(1998-2002)

# Project Information

**CONTRACT N°:** G1RD-CT-2000-00378

**ACRONYM:** LIFECON

**PROJECT TITLE:** Life Cycle Management of Concrete Infrastructures for Improved Sustainability



**PROJECT CO-ORDINATOR:** Technical Research Centre of Finland (VTT),  
VTT Building Technology  
Professor, Dr. Asko Sarja

## **PARTNERS:**

The Finnish Road Administration, Finland	Norwegian Building Research Institute, Norway
CT LAASTIT Oy Ab, Finland;	Kystdirektoratet, Norway
Optiroc Oy Ab, Finland	Millab Consult A.S., Norway
Technische Universität München, Germany	Centre for Built Environment, Sweden
OBERMAYER PLANEN+BERATEN, Germany	Gävle Kommun, Sweden
Norwegian University of Science and Technology, Norway	Ljustech Konsults AB, Sweden
Interconsult Group ASA, (Since 01. 01.2003: Interconsult Norgit AS), Norway	L.Öhmans Bygg AB, Sweden
	British Energy Generation Ltd, UK
	Heriot-Watt University, UK
	Centre Scientifique et Technique du Batiment CSTB, France.

**PROJECT DURATION:** FROM 01. 01.2003 TO 31. 12.2003



Project funded by the European Community under the  
Competitive and Sustainable Growth Programme  
(1998-2002)

## Deliverable Information

<b>Programme name:</b>	Growth Programme
<b>Sector:</b>	TRA 1.9 Infrastructures
<b>Project acronym:</b>	LIFECON
<b>Contract number:</b>	G1RD-CT-2000-00378
<b>Project title:</b>	Life Cycle Management of Concrete Infrastructures for Improved Sustainability
<b>Deliverable number:</b>	D2.3
<b>Deliverable title:</b>	METHODS FOR OPTIMISATION AND DECISION MAKING IN LIFETIME MANAGEMENT OF STRUCTURES Part I : Multi Attribute Decision Aid Methodologies (MADA) Part II : Quality Function Deployment (QFD) Part III : Risk Assessment and Control
<b>Deliverable version number:</b>	Updated Final Report
<b>Work package contributing to deliverable:</b>	WP 2
<b>Nature of the deliverable: (PR/RE/SP/TO/WR/OT)</b>	RE
<b>Dissemination level (PU/RE/CO):</b>	PU
<b>Type of deliverable (PD/WR):</b>	PD
<b>Contractual date of delivery:</b>	Final Delivery: Month 36
<b>Date of delivery:</b>	03.02.2004
<b>Author(s):</b>	Part I : Jérôme Lair, Asko Sarja Part II : Asko Sarja Part III : Tommi Rissanen
<b>Project co-ordinator:</b>	Asko Sarja

***Nature:***

PR - prototype (demonstrator), RE - report, SP - specification, TO - tool, WR - working report  
OT - other

***Dissemination level:***

PU - public usage, RE - restricted to project participants, CO - restricted to commission

***Type:***

PD - project deliverable, WR - working report

<b>Quality Assurance Form</b>		
Deliverable ID	D2.3	
Title	METHODS FOR OPTIMISATION AND DECISION MAKING IN LIFETIME MANAGEMENT OF STRUCTURES Part I : Multi Attribute Decision Aid Methodologies (MADA) Part II : Quality Function Deployment (QFD) Part III : Risk Assessment and Control	
Deliverable type	FINAL REPORT	
Author(s) of deliverable (Name and organisation)	Part I : Jérôme Lair, CSTB; Asko Sarja, VTT Part II : Asko Sarja, VTT Part III : Tommi Rissanen, VTT	
Reviewer(s)	Part I : Christine Kühn, Sascha Lay Part II : Christine Kühn, Sascha Lay Part III : Jérôme Lair, Marja-Kaarina Söderqvist	
Approved by reviewer(s)  (Reviewer's name and date)	P a r t I	Sign.: _____ Sign.: _____ Date: _____ Date: _____
	P a r t II	Sign.: _____ Sign.: _____ Date: _____ Date: _____
	P a r t III	Sign.: _____ Sign.: _____ Date: _____ Date: _____
Approved for release WP Leader / Co-ordinator	Sign.: _____ Sign.: _____ Date: _____ Date: _____	

## Lifecon Deliverables

<b>Deliverable No</b>	<b>Title of the Deliverable</b>
<b>D1.1</b>	Generic technical handbook for a predictive life cycle management system of concrete structures (Lifecon LMS)
<b>D1.2</b>	Generic instructions on requirements, framework and methodology for IT-based decision support tool for Lifecon LMS
<b>D1.3</b>	IT-based decision support tool for Lifecon LMS
<b>D2.1</b>	Reliability based methodology for lifetime management of structures
<b>D2.2</b>	Statistical condition management and financial optimisation in lifetime management of structures <ul style="list-style-type: none"> <li>• Part 1: Markov chain based LCC analysis</li> <li>• Part 2: Reference structure models for prediction of degradation</li> </ul>
<b>D2.3</b>	Methods for optimisation and decision making in lifetime management of structures <ul style="list-style-type: none"> <li>• Part I: Multi attribute decision aid methodologies (MADA)</li> <li>• Part II: Quality function deployment (QFD)</li> <li>• Part III: Risk assessment and control</li> </ul>
<b>D3.1</b>	Prototype of condition assessment protocol
<b>D3.2</b>	Probabilistic service life models for reinforced concrete structures
<b>D4.1</b>	Definition of decisive environmental parameters and loads
<b>D4.2</b>	Instructions for quantitative classification of environmental degradation loads onto structures
<b>D4.3</b>	GIS-based national exposure modules and national reports on quantitative environmental degradation loads for chosen objects and locations
<b>D5.1</b>	Qualitative and quantitative description and classification of RAMS (Reliability, Availability, Maintainability, Safety) characteristics for different categories of repair materials and systems
<b>D5.2</b>	Methodology and data for calculation of life cycle costs (LCC) of maintenance and repair methods and works
<b>D5.3</b>	Methodology and data for calculation of LCE (Life Cycle Ecology) in repair planning
<b>D6.1</b>	Validation of Lifecon LMS and recommendations for further development

**List of Contents**

PART I:.....	9
Multi Attribute Decision Aid Methodologies (MADA).....	9
Abstract.....	10
List of Contents.....	11
List of terms, definitions and symbols.....	13
1 Introduction.....	15
1.1 Objective.....	15
1.2 An introductory example.....	15
1.3 Methodology.....	15
1.4 Thresholds.....	16
1.4.1 Definition.....	16
1.4.2 Types of criteria.....	17
1.5 Weights (of criteria).....	19
1.5.1 Entropy methodology.....	19
1.5.2 Successive comparisons methodology.....	21
1.5.3 Analytical Hierarchy Process (AHP).....	22
1.6 Further definitions.....	25
2 Selection methods.....	27
2.1 “American way of thinking” / Complete aggregation.....	27
2.1.1 Additive Weighting Method.....	27
2.1.2 Weighted Product Method.....	28
2.1.3 Analytical Hierarchy Process (ASTM Standard: E 1765-98).....	29
2.2 “French way of thinking” / Partial aggregation.....	30
2.2.1 ELECTRE methods (Elimination Et Choix Traduisant la REalité).....	30
2.2.2 PROMETHEE.....	32
2.2.3 MELCHIOR.....	34
2.2.4 BORDA.....	34
2.2.5 COPELAND.....	35
2.2.6 ORESTE.....	35
2.3 Summary.....	35
3 Proposed methodology for LIFECON.....	39
3.1 General Objectives / Alternatives definition.....	40
3.1.1 Network, Object, Module, Component, detail and Material.....	40
3.1.2 Alternative definition.....	40
3.2 Attributes/Criteria.....	40
3.2.1 Assessment.....	43
3.2.2 Weights assessment.....	43
3.3 Alternative assessment.....	43
3.4 Multi-Attribute Decision Aid.....	43
3.5 Results.....	44
3.6 Sensitivity analysis.....	44

3.6.1	Generalities.....	44
3.6.2	Monte-Carlo simulation .....	44
4	Illustration .....	46
4.1	Objectives / Alternatives.....	46
4.2	Attributes / Criteria.....	46
4.2.1	Criteria.....	46
4.2.2	Weights.....	46
4.3	Alternative assessment.....	47
4.4	MADA.....	47
4.4.1	Additive weighting.....	48
4.4.2	Copeland.....	49
4.4.3	ELECTRE III .....	49
4.5	Results .....	51
4.6	Sensitivity analysis .....	53
4.6.1	Variation of the weights .....	53
4.6.2	Variation of the assessments .....	54
5	References .....	57
	APPENDIX 1.....	58
	APPENDIX 2.....	61
	PART II: .....	65
	Quality Function Deployment (QFD).....	65
	Abstract.....	66
	List of Contents.....	67
6	QFD method in the performance based management planning procedure of Lifecon LMS ..	68
6.1	QFD in performance based and optimising planning procedure .....	68
7	Principles of Quality Function Deployment Method .....	70
7.1	Short history of the QFD method .....	70
7.2	General use of QFD method.....	70
7.3	Generic description of QFD method.....	71
8	Procedure of QFD in Lifecon LMS .....	73
8.1	Alternative applications .....	73
8.2	Phases of the QFD procedure .....	73
8.3	Requirements and Properties in Lifecon LMS .....	74
8.3.1	Hierarchy of the requirements and properties .....	74
8.3.2	Performance Requirements and Properties .....	75
8.4	Aggregation of life cycle performance Requirements and Properties.....	78
8.4.1	Aggregation methods .....	78
8.4.2	Aggregation procedures .....	79
8.5	Selection of the Primary Requirements and Properties .....	83
9	IT support for QFD method .....	84
9.1	Direct Excel applications.....	84

9.2 Commercial programs .....	84
10 References .....	85
APPENDIX: Examples on the QFD procedure .....	87
PART III: .....	93
Risk Assessment and Control .....	93
Abstract .....	94
List of Contents .....	95
List of terms, definitions and symbols .....	96
11 Introduction .....	98
11.1 Aim of Lifecon risk assessment and control .....	98
11.2 Role of risk in construction sector .....	98
11.3 Quantification problem .....	99
12 Risk analysis methods .....	102
12.1 Common factors to all risk analysis methods .....	102
12.2 Preliminary hazard analysis (PHA) .....	103
12.3 Hazard and operability study (HAZOP) .....	103
12.4 Failure mode and effect analysis (FMEA) .....	104
12.5 Event tree analysis (ETA) .....	105
12.6 Fault tree analysis (FTA) .....	109
13 Lifecon risk assessment and control procedure .....	116
13.1 Introduction .....	116
13.2 The steps of the procedure .....	117
13.2.1 Identification of adverse incidents .....	117
13.2.2 Analysis of the identified adverse incidents .....	118
13.2.3 Quantitative risk analysis .....	121
13.2.4 Risk-based decision making .....	122
13.3 Using Lifecon risk assessment and control procedure in practice .....	123
13.4 Qualitative or quantitative risk analysis; Discussion .....	125
14 References .....	126
Appendices .....	127
A. Illustrative example of Lifecon risk quantification procedure .....	127



## **PART I:**

# **Multi Attribute Decision Aid Methodologies (MADA)**

**Authors: Jérôme Lair & Asko Sarja**

## **Keywords**

Lifecon, multi-criteria, multi-attribute, AHP, weighted method, decision making

## **Abstract**

This paper contains:

1 – Multi-Attribute Decision Aid terminology,

This first part presents the terms and notations used in Multi-Attribution Decision Analysis. Alternatives, Criteria (and their different types), Thresholds, and types of MADA method are presented. Tables of the main notations and definition are explained to simplify the reading.

2 – Presentation of the various existing methodologies (bibliographical study),

Several methodologies based on both “American and French ways of thinking” are presented more in details. A graph for selection is proposed as a summary (Chapter 2.3).

3 – Presentation of the proposed approach and the MADA software developed for LIFECON.

This last part firstly presents the methodology proposed for LIFECON LMS as well as the softwares developed during this project (MADA and Sensitivity analysis softwares). Finally a basic example is presented (Chapter 4).

## List of Contents

### Authors of Part I: Jérôme Lair & Asko Sarja

PART I:.....	9
Multi Attribute Decision Aid Methodologies (MADA).....	9
Abstract.....	10
List of Contents.....	11
List of terms, definitions and symbols.....	13
1 Introduction.....	15
1.1 Objective.....	15
1.2 An introductory example.....	15
1.3 Methodology.....	15
1.4 Thresholds.....	16
1.4.1 Definition.....	16
1.4.2 Types of criteria.....	17
1.5 Weights (of criteria).....	19
1.5.1 Entropy methodology.....	19
1.5.2 Successive comparisons methodology.....	21
1.5.3 Analytical Hierarchy Process (AHP).....	22
1.6 Further definitions.....	25
2 Selection methods.....	27
2.1 “American way of thinking” / Complete aggregation.....	27
2.1.1 Additive Weighting Method.....	27
2.1.2 Weighted Product Method.....	28
2.1.3 Analytical Hierarchy Process (ASTM Standard: E 1765-98).....	29
2.2 “French way of thinking” / Partial aggregation.....	30
2.2.1 ELECTRE methods (Elimination Et Choix Traduisant la REalité).....	30
2.2.2 PROMETHEE.....	32
2.2.3 MELCHIOR.....	34
2.2.4 BORDA.....	34
2.2.5 COPELAND.....	35
2.2.6 ORESTE.....	35
2.3 Summary.....	35
3 Proposed methodology for LIFECON.....	39
3.1 General Objectives / Alternatives definition.....	40
3.1.1 Network, Object, Module, Component, detail and Material.....	40
3.1.2 Alternative definition.....	40
3.2 Attributes/Criteria.....	40
3.2.1 Assessment.....	43
3.2.2 Weights assessment.....	43
3.3 Alternative assessment.....	43
3.4 Multi-Attribute Decision Aid.....	43

3.5	Results .....	44
3.6	Sensitivity analysis .....	44
3.6.1	Generalities.....	44
3.6.2	Monte-Carlo simulation .....	44
4	Illustration .....	46
4.1	Objectives / Alternatives.....	46
4.2	Attributes / Criteria.....	46
4.2.1	Criteria.....	46
4.2.2	Weights.....	46
4.3	Alternative assessment.....	47
4.4	MADA .....	47
4.4.1	Additive weighting .....	48
4.4.2	Copeland.....	49
4.4.3	ELECTRE III .....	49
4.5	Results .....	51
4.6	Sensitivity analysis .....	53
4.6.1	Variation of the weights .....	53
4.6.2	Variation of the assessments .....	54
5	References .....	57
	APPENDIX 1 .....	58
	APPENDIX 2.....	61

## List of terms, definitions and symbols

$a_i$	Alternative i
$C_j$	Criteria j
$w_j$	Weight associated to the criteria j
I	Indifference relation
Q	Weak preference relation
P	Strict preference relation
S	Outclassing relation
$>^v$	Veto threshold
$q(U_j)$	Indifference threshold (for the criteria j)
$p(U_j)$	Strict preference threshold (for the criteria j)
$U_j$	Utility function for a criteria j
$R(a_i)$	Ranking of the alternative i
$C_{ik}$	Concordance index (Electre method)
$D_{ik}$	Discordance index (Electre method)

Aggregation	<i>Process leading from information on the preferences by criteria to information on a global preference between alternatives.</i>
Comparison	<ul style="list-style-type: none"> <li>- <i>Method 1. (Choice) – We clarify the decision by choosing a subset of alternatives (as small as possible) in order to choose the final alternative. This subset contains optimum and sufficient alternatives, i.e. the satisfying alternatives.</i></li> <li>- <i>Method 2. (Sorting) – We sort the alternatives by categories. Each alternative is assigned to one and a single category (independent of other categories).</i></li> <li>- <i>Method 3 (Ranking) – We rank all or some of the alternatives (the most satisfying ones), by assigning a rank of ordering which allows a total or partial ranking.</i></li> <li>- <i>Method 4. (Description) – The problem is correctly stated by describing alternatives and their consequences.</i></li> </ul>
Alternative	<i>Alternatives of plans or designs or actions are the various possibilities to be compared.</i>
Attribute	<p><i>Attribute is the description of a property of a plan or design alternative.</i></p> <p><i>In order to choose between the alternatives, the decision-maker knows at least one of the following attributes:</i></p> <ul style="list-style-type: none"> <li>- <i>attributes with numerical assessment (cost, speed, environmental impact...), of a quantitative manner,</i></li> <li>- <i>other attributes, with a qualitative character (aesthetic, biodiversity...)</i></li> </ul>
Criteria	<p><i>Criteria are the different points of view used to select between the alternatives.</i></p> <p><i>A criterion expresses a decision-maker preference for a given attribute.</i></p>
Compensation	<i>Compensation between alternatives in the decision process means that an alternative with a very negative assessment on a criterion can be counterbalanced by other positive assessments, and thus becomes better than an alternative which has medium values for all the criteria.</i>
Cut threshold	<i>Lower limit defined for the degree of credibility in order to select only the more credible outclassing relations.</i>
Degree of credibility	<i>Computed value, in the range [0, 1], defining the “strength” of an outclassing relation.</i>
Discrimination threshold	<p><i>Value defining the limit:</i></p> <ul style="list-style-type: none"> <li>- <i>between two situation of preference for a considered criteria (concordance, discordance, indifference, preference and veto threshold)</i></li> </ul>

	<ul style="list-style-type: none"> <li>- between two situation of preference for a set of criteria (global concordance, global discordance),</li> <li>- between two values for the credibility of an outclassing relation.</li> </ul>
Distillation (Chapter 2.2.1)	<i>Downward and Upward Distillations: Calculations used in the ELECTRE method to rank respectively from the worst alternative, and from the best one.</i>
Incomparability	<i>No ability to choose between two alternatives.</i>
Indifference (Chapter 1.4)	<p><i>Two alternatives are considered indifferent if the difference between the values for a given criteria is lower than the indifference threshold.</i></p> <p><i>Let <math>q(U_j)</math> be an indifference threshold associated to criterion <math>j</math>.</i></p> <p><i>Then the indifference relation <math>I</math> is defined by:</i></p> <p><i><math>\forall a, b \in A, "a I b" \text{ if } U_j(b) - q(U_j) \leq U_j(a) \leq U_j(b) + q(U_j)</math></i></p>
Minimisation	<p><i>For some criteria, the less could be the worst as for quality ("Low quality" = "Bad alternative") or the best as for cost ("Low cost" = "Good alternative").</i></p> <p><i>In the second case, criteria are minimised before any calculation.</i></p>
Outclassing (Chapter 1.4)	<p><i>An outclassing relation <math>S</math> expresses the fact that alternative <math>a</math> is not strictly worse than alternative <math>b</math> with:</i></p> <p><i><math>\forall a, b \in A, "a S b" \text{ if } U_j(a) \geq U_j(b) + q(U_j(b))</math></i></p>
Pseudo criteria	<i>Refer to chapter 0</i>
Strict preference (Chapter 1.4)	<p><i>Let <math>p(U_j)</math> be a strict preference threshold associated to criterion <math>j</math>.</i></p> <p><i>Then the strict preference relation <math>P</math> is defined by:</i></p> <p><i><math>\forall a, b \in A, "a P b" \text{ if } U_j(a) &gt; U_j(b) + p(U_j)</math></i></p>
True criteria	<i>Refer to chapter 0</i>
Veto (Chapter 1.4)	<i>The difference between two alternatives "a" and "b" for criterion <math>j</math> is such that <math>a</math> is definitely unacceptable in comparison with <math>b</math> (the outclassing of <math>a</math> compared to <math>b</math> is rejected even if <math>a</math> outclass <math>b</math> concerning all the other criteria).</i>
Weak preference (Chapter 1.4)	<p><i>The weak preference relation <math>Q</math> is defined by:</i></p> <p><i><math>\forall a, b \in A, "a Q b" \text{ if } U_j(b) + q(U_j) &lt; U_j(a) \leq U_j(b) + p(U_j)</math></i></p>

# 1 Introduction

## 1.1 Objective

The objective of this report is the proposition of a decision aid methodology based on multi-criteria tools for the use in the Lifecon LMS Life Cycle Management System

We provide the users (mainly owners, planners and designers of infrastructures) with multi-attribute decision aid methodologies to enable the decision on criteria regarding the various human requirements, lifetime economy, lifetime ecology and cultural aspects, and further decisions based on these criteria.

## 1.2 An introductory example

As an example, we propose **attributes** and corresponding **criteria** that could be taken into account for the choice between cars (Figure 1):

- attribute “economy” (composed of two criteria: purchasing cost and maintenance cost),
- attribute “Human requirements”(maximum speed, comfort, level of equipments, Noise),
- attribute “Environment” (gas consumption, impact on air pollution, recycle-ability of materials).

	ATTRIBUTES / CRITERIA							
	Economy		Human requirements			Environment		
ALTERNATIVES	Purchasing cost	Maintenance cost	Maximum speed	Comfort	Noise	Average gas consumption	Impact on air pollution	Recycle-ability
Car 1	12000 €	Low	165 km/h	Medium	4	8 l/100km	High	Medium
Car 2	16000 €	Medium	195 km/h	Good	2	6 l/100km	Low	Good

Figure 1: Multi-attribute decision example

For each **criterion**, a **utility function** is defined:

- “Cost” is a quantitative criterion; in the range [0, 100 000 €],
- “Maintenance cost” is a qualitative criterion, in the domain of (Low, Medium, High),
- ...
- “Noise” is a qualitative numerical criterion, with values of [0, 1, 2, 3, 4, 5]

## 1.3 Methodology

### Aggregation:

“Aggregation” is a process leading from information on the preferences by criteria to information on a global preference between alternatives.

### Comparison method:

- Method 1. ( Choice) – We clarify the decision by choosing a subset of alternatives (as small as possible) in order to choose the final alternative. This subset contains optimum and sufficient satisfying alternatives.
- Method 2. (Problematic  $\beta$  - Sorting) – We assign the alternatives to categories. Each alternative is assigned to a single category (independent of other categories).
- Method 3. ( Ranking) – We rank all or some of the alternatives (the most satisfying ones), by assigning a rank of ordering which allows a total or partial ranking.
- Method 4. ( Description) – The problem is correctly stated by describing alternatives and their consequences.

### Core:

The core is a subset of alternatives fulfilling the following conditions:

- any alternative not belonging to the core is outclassed by at least one alternative of the core,
- no alternative belonging to the core is outclassed by another alternative of the core.

## 1.4 Thresholds

### 1.4.1 Definition

The utility function  $U_j$  describes the criterion  $j$  ( $U_j(a)$  and  $U_j(b)$  are the values of alternative  $a$  and  $b$  for the considered criterion  $j$ ), with  $A$  being the set of alternatives.

#### Strict preference (“P”):

Let  $p(U_j)$  be a strict preference threshold associated to criterion  $j$ .

Then the strict preference relation  $P$  is defined by

$$\forall a, b \in A, \text{“} a P b \text{” if } U_j(a) > U_j(b) + p(U_j)$$

*Example: If the preference threshold for the criteria “Average maximum speed” is  $p(U_{Speed}) = 20$  km/h*

$$\text{Then } U_{Speed}(Car 2) > U_{Speed}(Car 1) + p(U_{Speed})$$

$$\text{since } 195 > 165 + 20$$

*→ Car 2 is strictly preferred to Car 1*

#### Indifference (“I”):

Let  $q(U_j)$  be an indifference threshold associated to criterion  $j$ .

Then the indifference relation  $I$  is defined by

$$\forall a, b \in A, \text{“} a I b \text{” if } U_j(b) - q(U_j) \leq U_j(a) \leq U_j(b) + q(U_j)$$

*Example: If the indifference threshold for the criteria “Average maximum speed” is  $q(U_{Speed}) = 40$  km/h*

$$\text{Then } U_{Speed}(Car 2) \leq U_{Speed}(Car 1) + q(U_{Speed})$$

$$\text{since } 165 - 40 \leq 195 \leq 165 + 40$$

*→ Choice between Car 1 and car 2 is indifferent (we can't prefer one to the other)*

#### Weak preference (“Q”):

The weak preference relation  $Q$  is defined by

$$\forall a, b \in A, \text{“} a Q b \text{” if } U_j(b) + q(U_j) < U_j(a) \leq U_j(b) + p(U_j)$$

*Example: If the preference threshold for the criteria “Average maximum speed” is  $p(U_{Speed}) = 40$  km/h*

*and the indifference threshold is  $q(U_{Speed}) = 20$  km/h*

$$\text{Then } U_{Speed}(Car 1) + q(U_{Speed}) \leq U_{Speed}(Car 2) \leq U_{Speed}(Car 1) + p(U_{Speed})$$

$$\text{since } 165 + 20 \leq 195 \leq 165 + 40$$

*→ Car 1 is weakly preferred to Car 2*

*→ BUT not strictly preferred (we don't have  $U_{Speed}(Car 2) > U_{Speed}(Car 1) + p(U_{Speed})$ )*

#### Outclassing (“S”):

An outclassing relation  $S$  expresses the fact that alternative  $a$  is not “strictly worse” than alternative  $b$  with:

$$\forall a, b \in A, \text{“} a S b \text{” if } U_j(a) \geq U_j(b) + q(U_j(b))$$

“Outclassing” means “A strictly preferred to B” OR “A weakly preferred to B”.

*Example: If the indifference threshold for the criteria “Average maximum speed” is  $q(U_{Speed}) = 20$  km/h*



Then  $U_{Speed}(Car\ 2) \geq U_{Speed}(Car\ 1) + q(U_{Speed})$   
 since  $195 \geq 165 + 20$   
 $\rightarrow$  Car 2 outclasses Car 1 (Weak preference)

*Example:* If the indifference threshold for the criteria "Average maximum speed" is  $q(U_{Speed}) = 20$  km/h and the preference threshold is  $p(U_{Speed}) = 40$  km/h, and  $U_{Speed}(Car\ 2) = 210$  km/h (instead of 195 km/h)

Then  $U_{Speed}(Car\ 2) \geq U_{Speed}(Car\ 1) + q(U_{Speed})$  AND  $U_{Speed}(Car\ 2) \geq U_{Speed}(Car\ 1) + p(U_{Speed})$   
 since  $210 \geq 165 + 20$  AND  $210 \geq 165 + 40$   
 $\rightarrow$  Car 2 outclasses Car 1 (Strict preference)

### Veto:

A veto threshold  $>^v$  is also defined.

$a >^v b$  means that the difference between a and b for criterion j is such that a is definitely unacceptable in comparison with b (the outclassing of a compared to b is rejected even if a outclass b concerning all the other criteria).

*Example:* If the veto threshold for the criteria "Average maximum speed" is  $v(U_{Speed}) = 20$  km/h

Then  $U_{Speed}(Car\ 1) + v(U_{Speed}) < U_{Speed}(Car\ 2)$   
 since  $165 + 20 < 195$   
 $\rightarrow$  Car 2 is definitely preferred to Car 1 (whatever are the other criteria)

These definitions are not valid for some criteria. Indeed, according to the criteria, the less could be the worst as for quality, speed, ... or the best as for noise, cost, consumption. This characteristic is called minimisation.

### 1.4.2 Types of criteria

Various types of criteria could be defined according to the quantity of considered thresholds: true, quasi, pseudo and pre-criteria.

When comparing the values "a" and "b" of two alternatives for one criterion, various potential decisions are possible according to the type of criterion (Figure 2).

*Example:*

Let A and B be two alternatives, "a" and "b" their respective value for the considered criterion.

Then for the *true criteria*:

- if  $a > b$  then "A outclasses B",
- if  $a = b$  then there is "indifference between A and B",
- if  $a < b$  then "A is outclassed by B".

*True criteria* are too limited: it's a "white or black decisions", i.e. preference of one alternative except if alternative values are equal.

*Pseudo-criteria* include a gradation in preference (strict, weak preference or indifference). However, they require more information, i.e. the definition of the strict preference (p) and weak preference (q) thresholds.

Then:

- if  $b < (a - p)$  then "A strictly preferred to B",
- if  $(a - p) < b < (a - q)$  then "A weakly preferred to B",
- if  $(a - q) < b < (a + q)$  then "Indifference between A and B",
- if  $(a + q) < b$  then "B weakly preferred to A",
- if  $(a + p) < b$  then "B strictly preferred to A".

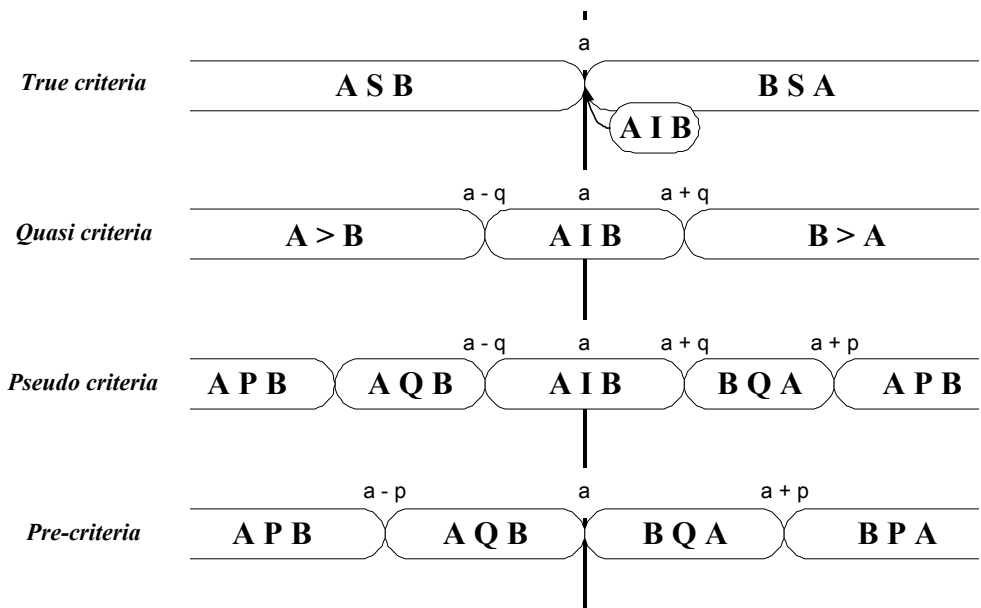

Figure 2: Criteria definition

We will use pseudo-criteria which are the most complete. They enable “fuzzy comparisons” instead of “white or black decisions”. Figure 3 and Figure 4 illustrate this principle. When comparing two alternatives A and B, the decision is:

- based on the comparison of the values of A and B for *true criteria*,
- based on the comparison of the values of A and B AND the value of the difference (A-B) for *pseudo-criteria*.

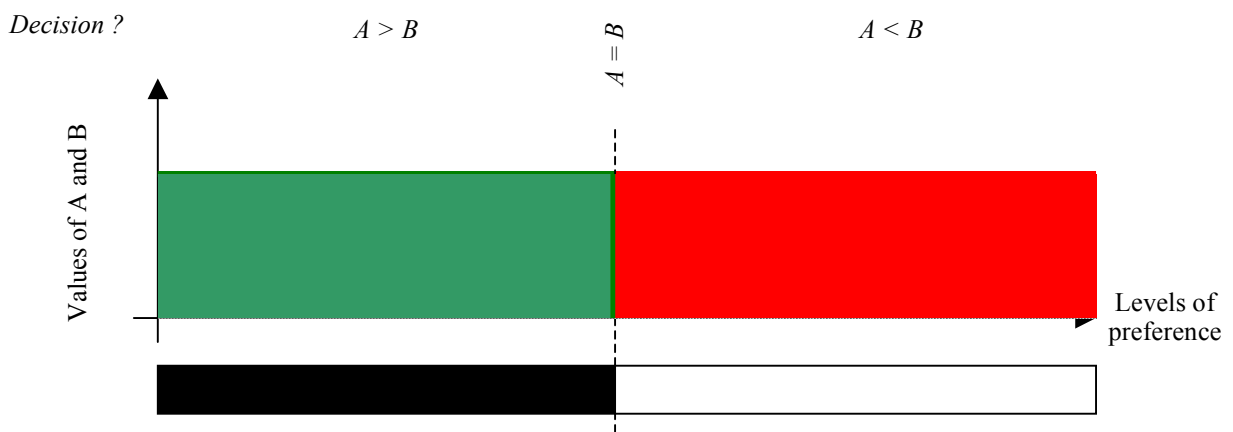

Figure 3: "White or black decisions"

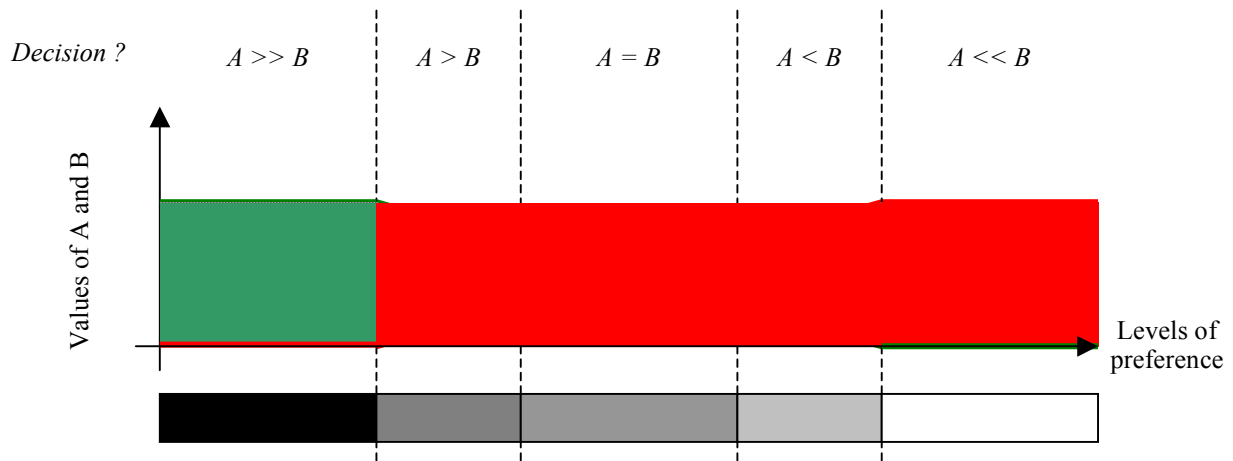

Figure 4: "Fuzzy decisions"

## 1.5 Weights (of criteria)

A weight expresses the importance given by the user to a criterion.

They have to be assessed in order to represent the decision maker preferences: the higher the weight is, the higher the preference is.

The relative importance of each criterion is difficult to be assessed. In order to help the user who doesn't know the criteria weights, we propose some guidelines.

Several methodologies for weight determination are available:

- entropy methodology,
- simple ranking methodology,
- simple cardinal assessment methodology,
- successive comparisons methodology,
- eigen values methodology,
- analytical Hierarchy Process (AHP): ASTM E1765-9.

We will not detail with each methodology, but only the entropy methodology, the "successive comparisons methodology" ("Revised Churchman Ackoff Technique") and the "Analytical Hierarchy Process".

The last one is programmed into LIFECON software.

### 1.5.1 Entropy methodology

The relative importance of a criterion  $j$ , measured by a weight  $w_j$ , is proportional to the quantity of information supplied by this criterion. The larger the range of values for a criterion (i.e. the more easy it is to rank the alternatives), the higher is the weight of the particular criterion. The procedure is as follows:

(1) normalisation of alternatives evaluations ( $a_{ij}$ ): dividing by the sum (for each criterion),

(2) entropy ( $E$ ) assessment for each criterion ( $j$ ) with  $E_j = -\frac{1}{\ln(m)} \cdot \sum_i a_{ij} \cdot \ln(a_{ij})$  ( $m$  number of alternatives),

(3) assessment of the scattering measure  $D_j = 1 - E_j$ ,

(4) assessment of weights with  $w_j = \frac{D_j}{\sum_j D_j}$ .

Example:

Let us assess the weights of the following criteria, for the following set of alternatives.

	Criteria					
	Safety	Health	Investment costs	Future costs	Environmental impacts	Aesthetic
Alternative 1	4	1	100	20	4	16
Alternative 2	3	1	80	30	1	14
Alternative 3	2	1	85	30	5	6
Alternative 4	4	2	130	25	3	10
Alternative 5	1	1	30	35	6	2
Alternative 6	1	1	90	30	2	12
Alternative 7	2	1	88	20	7	8

Figure 5: Weights determination with entropy methodology

(1) The first step consists in normalisation.

The sum of alternatives for each column gives:

Criteria	Safety	Health	Investment costs	Future costs	Environmental impacts	Aesthetic
Sum	17	8	603	190	28	68

The new table, obtained after normalisation is:

	Criteria					
	Safety	Health	Investment costs	Future costs	Environmental impacts	Aesthetic
Alternative 1	0.235	0.125	0.166	0.105	0.143	0.235
Alternative 2	0.176	0.125	0.133	0.158	0.036	0.206
Alternative 3	0.118	0.125	0.141	0.158	0.179	0.088
Alternative 4	0.235	0.250	0.216	0.132	0.107	0.147
Alternative 5	0.059	0.125	0.050	0.184	0.214	0.029
Alternative 6	0.059	0.125	0.149	0.158	0.071	0.176
Alternative 7	0.118	0.125	0.146	0.105	0.250	0.118

(2) We then calculate the entropy for each criterion by means of  $E_j = -\frac{1}{\ln(m)} \cdot \sum_i a_{ij} \cdot \ln(a_{ij})$  (with  $m = 7$ ):

	Safety	Health	Investment costs	Future costs	Environmental impacts	Aesthetic
$E_j$	0.937	0.980	0.970	0.990	0.930	0.937

(3) We assess the scattering measure  $D_j$  for each criterion:

	Safety	Health	Investment costs	Future costs	Environmental impacts	Aesthetic
$D_j$	0.063	0.020	0.030	0.010	0.070	0.063

(4) We finally assess the weights by means of  $w_j = \frac{D_j}{\sum_j D_j}$ , with  $\sum_j D_j = 0,2564$

	<b>Safety</b>	<b>Health</b>	<b>Investment costs</b>	<b>Future costs</b>	<b>Environmental impacts</b>	<b>Aesthetic</b>
<b>w<sub>j</sub></b>	0.245	0.080	0.118	0.038	0.274	0.245

This methodology is totally objective. This “neutral” aspect is interesting in conflicting context or when it becomes difficult to determine weights.

Nevertheless, decision makers can intervene by multiplying each weight by a factor taking into account his preferences. Weights then gather objectivity of scattering measure as well as decision makers subjective preferences.

### 1.5.2 Successive comparisons methodology

The successive steps are:

- (1) ranking of criteria according to the importance,
- (2) assessment of criteria according to a cardinal scale,
- (3) systematic comparison of each criteria to the union of the following ones (comparisons between criteria and coalition of criteria),
- (4) checking of the consistence between the cardinal ranking (step 2) and the comparisons (step 3): possible modification of the value in case of conflict with the relations obtained by comparisons
- (5) normalisation of the obtained values.

Example:

- (1) ranking of criteria according to the importance,

1<sup>st</sup> Performance (P)

2<sup>nd</sup> Cost (C)

3<sup>rd</sup>/4<sup>th</sup> (placed equal) Energy consumption (EC) and Service life (SL)

5<sup>th</sup> Waste (W)

- (2) assessment of criteria according to a cardinal scale,

<i>Criteria</i>	<i>P</i>	<i>C</i>	<i>EC</i>	<i>SL</i>	<i>W</i>
<i>Weights</i>	5	4	2,5*	2,5*	1

\* Share of the points between the criteria for which the alternatives are placed equal (2,5 instead of 3 and 2).

- (3) systematic comparison of each criteria to the union of the following ones

1 - P compared with C+EC+SL+W	4 - C compared with EC+SL+W	6 - EC compared with SL+W
2 - P compared with C+EC+SL	5 - C compared with EC+SL	
3 - P compared with C+EC		

Starting with the first set of criteria (first column above), the user has to go down till the left criterion (in the example here: P) is considered as less important than the right coalition (C+EC+SL+W, C+EC+SL, ...). The user proceeds similarly for the two other columns.

Let us assume that the user answers:

- 1)  $P > C+EC$  but  $P < C+EC+SL$

- 2)  $C < EC + SL$
- 3)  $EC = SL$  (already known by the ranking)

(4) checking of the coherence between the cardinal ranking (step 2) and the comparisons (step 3): possible modification of the value in case of conflict with the relations obtained by comparisons

Comparing with the cardinal assessment:

- 3)  $EC = SL \rightarrow 2,5 = 2,5$  Correct
- 2)  $C < EC + SL \rightarrow 4 < 2,5 + 2,5$  Correct
- 1)  $P > C + EC \rightarrow 5 < 4 + 2,5$  Incorrect

Weights have to be modified to achieve a correct comparison.

(5) normalisation of the obtained weights.

Criteria	<i>P</i>	<i>C</i>	<i>EC</i>	<i>SL</i>	<i>W</i>
Weights	0,44	0,23	0,14	0,14	0,06

### 1.5.3 Analytical Hierarchy Process (AHP)

The Analytical Hierarchy Process is a multi-criteria decision-making approach and was introduced by Saaty (1977). The AHP has attracted the interest of many researchers mainly due to the fact that the required input data are rather easy to obtain. The AHP is a decision support tool which can be used to solve complex decision problems. This method is standardised for practical use in ASTM standard E 1765-98.

The relevant information is derived by using a set of pairwise comparisons. These comparisons are used to obtain the weights of importance of the decision criteria. A Consistency Index indicates whether the pairwise comparisons are consistent.

The principle of this methodology is the assessment of the relative importance of each criterion over the others. In the following table (Figure 6), the values of the pairwise comparisons are members of the set  $\{9; 8; 7; 6; 5; 4; 3; 2; 1; 1/2; 1/3; 1/4; 1/5; 1/6; 1/7; 1/8; 1/9\}$ . The meaning of these values is detailed in Figure 7. If the preference of criterion *i* over criterion *j* is valued *x*, then the preference of criterion *j* over criterion *i* is valued  $1/x$ . The user just has to fill in the lower part of the matrix (white cells). Intermediate values 2, 4, 6 and 8 and their inverse values  $1/2$ ,  $1/4$ ,  $1/6$  and  $1/8$  are used to introduce more latitude in the comparison.

	Criterion 1	Criterion 2	...	Criterion i	...	Criterion j	...	Criterion n
Criterion 1	1							
Criterion 2		1						
...			1					
Criterion i				1				
...					1			
Criterion j						1		
...							1	
Criterion n								1

Figure 6: Pairwise comparisons

Preference of criterion i over criterion j	Definition	Preference of criterion j over criterion i
1	Equal importance	1
2		1/2
3	Weak importance of one over another	1/3
4		1/4
5	Essential or strong importance	1/5
6		1/6
7	Demonstrated importance	1/7
8		1/8
9	Absolute importance	1/9

Figure 7: Levels of preference

“Given a judgement matrix with pairwise comparisons, the corresponding maximum left eigenvector is approximated by using the geometric mean of each row”<sup>1</sup> (that is to say, the elements in each row are multiplied with each other and then the n-th root is taken, with n being the number of criteria). Next, the numbers are normalized by dividing them with their sum. We obtain a vector called *vector of priorities*.

Perfect consistency rarely occurs in practice. “In the AHP the pairwise comparisons in a judgement matrix are considered to be adequately consistent if the corresponding *Consistency Ratio* (CR) is less than 10%”.

First, the *Consistency Index* (CI) is assessed. “This is done by adding up the columns in the judgement matrix and multiplying the resulting vector by the vector of priorities”. We thus obtain  $\delta_{\max}$ . With this, we calculate

$$CI = \frac{\delta_{\max} - n}{n - 1}.$$

“The concept of *Random Consistency Index* (RCI) was also introduced by Saaty in order to establish an upper limit on how much inconsistency may be tolerated in a decision process”. The RCI values for different n values are given in Figure 8.

n	1	2	3	4	5	6	7	8	9	10	11	12	13	14	15
RCI	0	0	0.58	0.9	1.12	1.24	1.32	1.41	1.45	1.49	1.51	1.48	1.56	1.57	1.59

Figure 8: Random Consistency Index (function of the number of criteria)

Then  $CR = \frac{CI}{RCI}$ . If the CR value is greater than 0.10, then a re-evaluation of the pairwise comparisons is recommended.

The whole methodology has been programmed in order to simplify the use of the AHP method.

We suggest the user to build a pre-ranking of criteria before establishing pairwise comparisons in order to reach more easily the 10% limit of the Consistency Ratio.

<sup>1</sup> From “Determining the most important criteria in maintenance decision making” E. Triantaphyllou et al. Published in Quality in Maintenance Engineering, Vol.3, No.1, pp. 16-28, 1997.

Example:

Let us assess the weights of the criteria listed in Figure 1 for the selection of cars (The user just have to fill in the yellow cells of the table).

The pre-ranking of criteria by the user is the following:

- “Purchasing cost”, “Comfort”, “Gas consumption” and “Maintenance cost” are the four major criteria,
- “Noise” and “Maximum speed” are secondary criteria,
- Finally, “Impact on air pollution” and “Recycleability” are minor criteria.

Accordingly, he then fills in the pairwise comparisons table (horizontally) with the rate of preference, on the basis of the levels of preference listed in Figure 7.

The easiest way may be:

- to start with the second criteria “Maintenance cost” and compare it with “Purchasing cost” (first criteria), for instance “Purchasing cost” has an “essential or strong importance” relatively to “Maintenance cost” (the value is lower than one because the considered criteria “Maintenance cost” is less important than the criteria “Purchasing cost”,
- to do the same with the third criteria (maximum speed),
- and to go on with the other criteria.

		1	2	3	4	5	6	7	8
		Purchasing cost	Maintenance cost	Maximum speed	Comfort	Noise	Gas consumption	Impact on air pollution	Recycle-ability
1	Purchasing cost	1	5	9	1	7	3	9	9
2	Maintenance cost	1/5	1	5	3	3	1	5	9
3	Maximum speed	1/9	1/5	1	1/7	1	1/5	1	3
4	Comfort	1	1/3	7	1	3	1	7	9
5	Noise	1/7	1/3	1	1/3	1	1/3	3	5
6	Gas consumption	1/3	1	5	1	3	1	5	7
7	Impact on air pollution	1/9	1/5	1	1/7	1/3	1/5	1	3
8	Recycle-ability	1/9	1/9	1/3	1/9	1/5	1/7	1/3	1

Figure 9: Pairwise comparisons

For each row of the table, we calculate the product of values, to the power “1/number of criteria”:

The first value corresponding to the first row is:  $V(1) = (1 \times 5 \times 9 \times 1 \times 7 \times 3 \times 9 \times 9)^{1/8}$

We obtain the following vector of priorities:  $V = (4,078; 2,118; 0,457; 2,141; 0,729; 1,907; 0,398; 0,214)$  which is normalised dividing each term by the sum of its terms.

The sum is  $4,078+2,118+0,457+2,141+0,729+1,907+0,398+0,214=12,042$ ,

The normalised vector of priorities is:  $V = (0,339; 0,176; 0,038; 0,178; 0,060; 0,158; 0,033; 0,018)$

The consistency index is then calculated.

The sum of the columns in Figure 9 gives:  $S = (3,009; 8,178; 29,333; 6,730; 18,533; 6,876; 31,333; 46)$

S and V are multiplied to obtain  $\delta_{\max}$ :  $\delta_{\max} = S(1) \times V(1) + S(2) \times V(2) + \dots + S(8) \times V(8) = 8,831$ .

The Consistency Index CI is  $CI = \frac{\delta_{\max} - n}{n - 1} = \frac{8,831 - 8}{8 - 1} = 0,1187$ .

With  $RCI = 1,41$  (corresponding to 8 criteria), we obtain:  $CR = \frac{CI}{RCI} = \frac{0,1187}{1,41} = 0,084 < 0,1$



CR being lower than 0,1, the pairwise comparisons are consistent and we can use the weights produced with this methodology. If not, the user just has to refine the pairwise comparison, identifying the ones that are not consistent with the obtained ranking of criteria. Successive refinements will lead to a consistent result.

## 1.6 Further definitions

### Compensation:

Compensation between alternatives in the decision process means that an alternative with a very negative assessment on a criterion can be counterbalanced by other positive assessments, and thus becomes equal or better than an alternative which has medium values for all the criteria.

For instance, we compare the two alternatives  $A_1$  and  $A_2$  by means of 5 criteria (in the range  $[0, 15]$ ).

The “mean value” leads to “ $A_1$  is equal to  $A_2$ ”, even though  $A_1$  has a bad assessment for  $C_5$ .

The “mean value” involves compensation.

Alternatives	Criteria					Mean
	$C_1$	$C_2$	$C_3$	$C_4$	$C_5$	
	$U=[0, 15]$	$U=[0, 15]$	$U=[0, 15]$	$U=[0, 15]$	$U=[0, 15]$	
$A_1$	12	12	12	12	2	10
$A_2$	10	10	10	10	10	10

Figure 10: Compensation

### Incomparability:

Incomparability between alternatives means that we are not able to choose one of them.

For instance (Figure 11), when comparing the alternatives  $A_1$  and  $A_2$  by means of 2 criteria  $C_1$  and  $C_2$  (in the range  $[0, 15]$ ), with the same weights  $W_1$  and  $W_2$ , we are not able to decide which one is preferable.

Alternatives	Criteria	
	$C_1$	$C_2$
	$U=[0, 15]$	$U=[0, 15]$
	$W_1=1$	$W_2=1$
$A_1$	10	5
$A_2$	5	10

Figure 11: Incomparability

Note: Incomparability also appears in the decision process when there are uncertainties in the available information. Two alternatives could be considered as incomparable even if there is a slight difference in the assessment (uncertainty in measurements for instance).

### Properties of a set of criteria:

A set of criteria should have three properties:

- exhaustive,
- consistent,
- non redundant.

These notions are defined hereafter.

### Exhaustive:

For a set of criteria, we must not have two equal alternatives A and B for the considered set of criteria if we can say “A is preferred to B” or “B is preferred to A”.

Consistent:

If two alternatives A and B are equal for a set of criteria, then the increase of the value A for one criterion and/or the decrease of B for another criterion must involve “A is preferred to B”.

Non redundant:

Removing one criterion leads to the loss of the exhaustivity and consistency properties.

Independence of criteria:

We must be able to rank the alternatives for a given criteria, without knowing the values of these alternatives for other criteria.

For instance, when studying “raw material depletion”, we usually consider:

- consumed quantities,
- available resources,
- renewability.

Dependence is for instance: “We couldn’t judge the impact of the consumption of 50kg of one material in comparison of 100kg of another one if we don’t know their available resources and their renewability.”

Minimisation:

For some criteria, the less could be the worst as for quality (“Low quality” = “Bad alternative”) or the best as for cost (“Low cost” = “Good alternative”).

In the second case, criteria are minimised before any calculation (transformation of the utility function so that the less means the worst).

## 2 Selection methods

This chapter describes the most common methods for selection between alternatives.

Three types of methodologies have been collected in the literature (refer to chapter 5):

- weighted methods such as additive weighting and weighted product (set of methodologies making use of the relative importance of criteria thanks to weights and leading to an aggregated results, i.e. a mark),
- outclassing methods such as ELECTRE, PROMETHEE, ... methodologies (set of methodologies making use of *outclassing*<sup>2</sup> concept),
- ordinal methods (set of methodologies for which the result only depends on the initial ordinal ranking).

Type of method	Method	Selection procedure	Type of criteria	Thresholds <sup>3</sup>
Aggregation method	Additive weighting	Ranking	True	NO
	Weighting product	Ranking	True	NO
Outclassing method	ELECTRE IS	Choice	Pseudo	YES P, I, V
	ELECTRE III	Ranking	Pseudo	YES P, I, V
	ELECTRE IV	Ranking	Pseudo	YES P, I, V
	ELECTRE TRI	Sorting	Pseudo	YES P, I, V
	PROMETHEE I	Choice	All	YES P, I
	PROMETHEE II	Ranking	All	YES P, I
	EXPROM I	Choice	All	YES P, I
	EXPROM II	Ranking	All	YES P, I
Ordinal method	MELCHIOR	Choice	Pseudo	YES P, V
	BORDA	Ranking	True	NO
	COPELAND	Ranking	True	NO
	ORESTE	Choice	Pseudo	YES P, V

Figure 12: MADA methodologies

Other methods such as MUNDA, MAUT and UTA, REGIME, QUALIFLEX, PRAGMA, MACBETH, STEM, will not be detailed here, either because they are not commonly used, or because they are slight evolutions of method presented in Figure 12, or because they are not able to solve our problem.

In the following chapters, let us consider:

- m alternatives:  $a_1, \dots, a_i, \dots, a_m$ ,
- n criteria:  $C_1, \dots, C_j, \dots, C_n$ .
- the weights of the n criteria:  $w_1, \dots, w_i, \dots, w_n$ .

### 2.1 “American way of thinking” / Complete aggregation

#### 2.1.1 Additive Weighting Method

*Comparison method:* Ranking

*Criteria:* True criteria

*Thresholds:* No thresholds

<sup>2</sup> These methodologies compare alternatives two by two, criterion by criterion and lead to concordance and discordance indexes.

<sup>3</sup> P, I, V stands respectively for “Strict Preference”, “Indifference” and “Veto”.

*Principle:*

It is a simple well-known method based on aggregation (i.e. result is a mark) but too easily influenced by arbitrary choices (normalisation).

*Description:*

- normalisation step (data preparation). Four normalisation procedures are available:

Normalisation procedures	Procedure n°1	Procedure n°2	Procedure n°3	Procedure n°4
<b>Definition</b>	$V_i = \frac{a_i}{\max(a_i)} \cdot 100$	$V_i = \frac{a_i - \min(a_i)}{\max(a_i) - \min(a_i)} \cdot 100$	$V_i = \frac{a_i}{\sum a_i} \cdot 100$	$V_i = \frac{a_i}{\sqrt{\sum a_i^2}}$
<b>Interpretation</b>	% of the maximum of $a_i$	% of the range ( $\max a_i - \min a_i$ )	% of the total $\sum_i a_i$	Component n°i of the unit vector

Figure 13: Normalisation procedures

- normalisation of weights (division by the sum),
- assessment of ranking value  $R(a_i) = \sum_j w_j \cdot a_{ij}$  for each alternative,
- ranking of alternatives (The best alternative is the highest  $R(a_i)$ ).

*Note:*

- Criteria must be independent,
- Method is subject to compensation (an alternative with a very negative assessment on a criteria can be counterbalanced by other positive assessments)

### 2.1.2 Weighted Product Method

*Comparison method:* Ranking

*Criteria:* True criteria

*Thresholds:* No thresholds

*Principle:*

It's a similar methodology to chapter 2.1.1, but we multiply instead of adding up the values.

It is used to avoid the influence of the normalisation method on the final results (additive weighting).

*Description:*

- normalisation of weights (division by the sum),
- assessment of  $P(a_i) = \prod_j a_{ij}^{w_j}$  for each alternative,
- ranking of alternatives (The best alternative is the highest  $P(a_i)$ ).

*Note:*

- The main drawback of this methodology is the fact that it gives advantage/disadvantage to the utility that is far from the mean.
- Normalisation of criteria not needed.

### 2.1.3 Analytical Hierarchy Process (ASTM Standard: E 1765-98)

This standard deals with “Standard Practice for Applying Analytical Hierarchy Process (AHP) to Multiattribute Decision Analysis of Investments Related to Buildings and Building Systems”.

The Analytical Hierarchy Process (AHP) is one of a set of multi-attribute decision analysis (MADA) methods that considers non-monetary attributes (qualitative and quantitative) in addition to common economic evaluation measures (such as life-cycle costing or net benefits) when evaluating project alternatives.

The principles are mainly similar or same as presented above in connection to the French methods. Because the method is presented in details in the ASTM standard E 1765-98, only a short general presentation of the method is described in this report. Each user can directly apply the standard in all calculations using the Lifecon classification of attributes and criteria, as to be presented in this report in Chapter 3.

The procedure of this method is as follows:

1. Identify the elements of your problem to confirm that a MADA analysis is appropriate. Three elements are common to MADA problems:
  - MADA problems involve analysis of a finite and generally small set of discrete and predetermined options or alternatives.
  - In MADA problems no single alternative is dominant, that is, no alternative exhibits the most preferred value or performance in all attributes.
  - The attributes in a MADA problem are not all measurable in the same unit.
2. Identify the goal of the analysis, the attributes to be considered, and the alternatives to evaluate. Display the goal and attributes in a **hierarchy**.
  - A set of attributes refers to a complete group of attributes in the **hierarchy** which is located under another attribute or under the problem goal.
  - A **leaf attribute** is an attribute which has no attribute below in the hierarchy.
3. Construct a decision matrix with data on the performance of each alternative with respect to **each leaf attribute**.
4. Compare **in pairwise fashion** each alternative against every other alternative as to how much better one is than the other with respect to each leaf attribute. Repeat this process for each leaf attribute in the hierarchy.
5. Make **pairwise comparison** of the relative importance of each attribute in a given set; starting with sets at the bottom of the hierarchy, with respect to the attribute or goal immediately above that set.
6. Compute the final, overall desirability score for each alternative (this mathematical procedure is presented in details in the ASTM Standard: E 1765-98)

The ASTM Standard: E 1765-98 includes also examples which help in understanding and applying the method for different types of buildings. This standard refers also to several other ASTM standards which support the applications on different fields, e.g. the following:

- E 1670 Classification of the Serviceability of an office facility for management of operations and maintenance
- E 1701 Classification of serviceability of an office facility for manageability
- E 917 Practice for measuring life-cycle costs of buildings and building systems
- E 1480 Terminology of facility management (building related)
- ASTM Adjunct: Computer program and user’s guide to building maintenance, repair and replacement database for life cycle cost analysis, Adjunct to practices E917, E964, E1057, E1074 and E1121

ASTM Software Product: AHP/Expert Choice for ASTM building evaluation, Software to support practice E 1765.

## 2.2 “French way of thinking” / Partial aggregation

### 2.2.1 ELECTRE methods (Elimination Et Choix Traduisant la REalité)

The principle of this type of methodology is OUTCLASSING. Alternatives are compared two by two, criterion by criterion.

Let us note:

- $P^+(a_i, a_k) = \sum P_j$  ,  $j \in J^+(a_i, a_k)$ , i.e. the sum of the weights of criteria for which  $a_i$  is better than  $a_k$ .
- $P^=(a_i, a_k) = \sum P_j$  ,  $j \in J^=(a_i, a_k)$ , i.e. the sum of the weights of criteria for which  $a_i$  is equal to  $a_k$ .
- $P^-(a_i, a_k) = \sum P_j$  ,  $j \in J^-(a_i, a_k)$ , i.e. the sum of the weights of criteria for which  $a_i$  is worse than  $a_k$ .

*Concordance* expresses how much the criteria support the hypothesis between alternatives a and b: “a outclasses b”

*Concordance index* is  $C_{ik} = \frac{P^+(a_i, a_k) + P^=(a_i, a_k)}{P}$ , with  $P = P^+ + P^= + P^-$

*Discordance* (opposite to concordance) measures the opposition to the hypothesis: “a outclasses b” expressed by discordant criteria.

*Discordance index* is expressed by:

$$D_{ik} = \begin{cases} 0 & \text{if } J^-(a_i, a_k) = \emptyset \text{ (}\emptyset \text{ being the empty set)} \\ \frac{1}{\delta_j} \cdot \max\{g_j(a_k) - g_j(a_i)\} & ; j \in J^-(a_i, a_k) \end{cases}$$

$g_i(a_i)$  is the value of alternative  $a_i$  for criteria  $j$

Where  $\delta_j$  is the amplitude of the criteria  $j$  scale, criteria for which we have the maximum of discordance (i.e. alternative b is the “more better” than a).

*Outclassing* results from these two definitions:

“a outclasses b” means that concordance test is satisfied (a is at least as good as b for most of the criteria, concordance index is upper than a defined threshold c) and that the remaining criteria don’t involve a too strong opposition to this proposition “a outclasses b” (discordance index is lower than a defined threshold d).

The main differences between the various ELECTRE methods are (see Figure 12):

- the different use of concordance index,
- the different types of criteria (but we present only methods using pseudo-criteria).

#### 2.2.1.1 Choice method: ELECTRE IS (S stands for “Seuil” in French, i.e. “Threshold”)

*Comparison method:* Choice

*Criteria:* Pseudo-criteria

*Thresholds:* Strict preference, indifference, veto (one for each criterion).  
Global concordance

*Description:*

- construction of concordance matrix for each criterion ( $c_j(a_i, a_k)$ ),
- gathering of results in a global concordance matrix ( $C_{ik}$ ),
- construction of discordance matrix for each criterion ( $d_j(a_i, a_k)$ ),
- gathering of results in a global discordance matrix ( $D_{ik}$ ),
- from concordance and discordance matrices, construction of outclassing matrix ( $S(a_i, a_k)$ ),
- results expressed with outclassing graph and search of the core.

*Note:*

- easier than ELECTRE III,
- management of incomparability and indifference.

### 2.2.1.2 Ranking method: ELECTRE III

*Comparison method:* Ranking

*Criteria:* Pseudo-criteria

*Thresholds:* Strict preference, indifference, veto (one for each criterion).  
Discrimination (refer to List of terms, definitions and symbols).

*Description:*

- construction of concordance matrix for each criterion ( $c_j(a_i, a_k)$ ),
- results gathering in a global concordance matrix ( $C_{ik}$ ),
- construction of discordance matrix for each criterion ( $d_j(a_i, a_k)$ ),
- from global concordance matrix and discordance matrices, construction of belief matrix ( $\delta_{ik}$ ),
- ranking algorithm (downward and upward distillations, i.e. calculations ranking firstly from the worst alternative, secondly from the best one),
- ranking of alternatives according to their ranks in each distillation.

*Note:*

- use of “fuzzy outclassing” concept.
- management of incomparability and indifference.
- complex methodology taking into account minor differences in the assessments.

### 2.2.1.3 Ranking method: ELECTRE IV

*Comparison method:* Ranking

*Criteria:* Pseudo-criteria

*Thresholds:* Strict preference, indifference, veto (one for each criterion).  
Discrimination

*Description:*

- comparison of each couple of alternatives towards each criterion,
- for each couple of alternatives (a,b), search of a  $S_q$  b, a  $S_c$  b, a  $S_p$  b or a  $S_v$  b relations,
- affectation of a belief value to each outclassing relation,
- construction of a matrix of belief degrees,
- ranking algorithm (downward and upward distillations),
- ranking of alternatives according to their ranks in each distillation.

*Note:*

- method without weights.
- use of “fuzzy outclassing” concept.
- management of incomparability and indifference.
- complex methodology taking into account minor differences in the assessments.

#### **2.2.1.4 Sorting method: ELECTRE TRI**

*Comparison method:* Sorting

*Criteria:* Pseudo-criteria

*Thresholds:* Strict preference, indifference, veto (one for each criterion)  
Cut threshold  $\lambda$

*Description:*

- definition of “reference alternatives”, either without any consideration of potential alternatives (e.g. use of standards), or in order to sort alternatives by groups.
- assessment of concordance matrix by criterion using comparison of each alternative to a reference alternative.
- assessment of global concordance index.
- assessment of discordance matrix by criterion.
- construction of a belief degree matrix.
- implementation of outclassing relations (from belief degrees and cut threshold  $\lambda$ ).
- Allocation of each alternative to the various categories.

*Note:*

- judgement of each alternative independently of other alternatives (less sensitive than  $\gamma$  methodologies concerning alternatives with similar assessments).
- definition of one or several reference values (standards, etc...) for alternatives acceptance.

#### **2.2.2 PROMETHEE**

In PROMETHEE (Preference Ranking Organisation METHod for Enrichment Evaluation) alternatives are compared two by two, criterion by criterion. PROMETHEE methods are based on preference information.

EXPROM methods are extensions of PROMETHEE methods and allow the distinction between strict and weak preferences.

##### **2.2.2.1 PROMETHEE I**

*Comparison method:* Choice

*Criteria:* All types

*Thresholds:* Strict preference, indifference (no thresholds for true criteria)

*Description:*

- construction of a preference matrix for each criterion ( $S_j(a_i, a_k)$ ),
- normalisation of weights,
- results gathering in a global preference matrix ( $C_{ik} = \sum_j w_j \cdot S_j(a_i, a_k)$ ),
- assessment of input and output flows (respectively  $\phi_{i+} = \sum_k C_{ik}$  and  $\phi_{i-} = \sum_k C_{ki}$ )



- and identification of the outclassing relations between alternatives, on the basis of the following rule: the

$$\text{alternative } a_i \text{ outclasses } a_k \text{ if: } = \begin{cases} \phi_{i+} > \phi_{k+} \text{ and } \phi_{i-} < \phi_{k-} \\ \text{or } \phi_{i+} > \phi_{k+} \text{ and } \phi_{i-} = \phi_{k-} , \\ \text{or } \phi_{i+} = \phi_{k+} \text{ and } \phi_{i-} < \phi_{k-} \end{cases}$$

*Note:*

- methodology less sensitive to the variations of the values of pseudo criteria thresholds,
- management of indifference.

### 2.2.2.2 PROMETHEE II

*Comparison method:* Ranking

*Criteria:* All types

*Thresholds:* Strict preference, indifference (no thresholds for true criteria)

*Description:*

- construction of a preference matrix for each criterion ( $S_j(a_i, a_k)$ ),
- normalisation of weights,
- results gathering in a global preference matrix ( $c_{ik} = \sum_j w_j \cdot S_j(a_i, a_k)$ ),
- assessment of input and output flows,
- from input and output flows (similar to PROMETHEE I), assessment of net flows ( $\phi_i = \phi_{i+} - \phi_{i-}$ ),
- identification the outclassing relations between alternatives and ranking (the higher the net flow is, the best is the alternative).

*Note:*

- methodology less sensitive to the variations of the values of pseudo criteria thresholds,
- management of indifference.

### 2.2.2.3 EXPROM I (Extension of PROMETHEE)

*Comparison method:* Choice

*Criteria:* All types

*Thresholds:* Strict preference, indifference (no thresholds for true criteria)

*Description:*

- normalisation of weights,
- construction of a preference matrix for each criterion,
- results gathering in a global weak preference matrix,
- construction of a strict preference matrix for each criterion,
- results gathering in a global strict preference matrix,
- construction of a global preference matrix from weak and strict preference matrices,
- assessment of input and output flows,
- identification of the outclassing relations between alternatives.

*Note:*

- management of indifference.

#### **2.2.2.4 EXPROM II**

*Comparison method:* Ranking

*Criteria:* All types

*Thresholds:* Strict preference, indifference (no thresholds for true criteria)

*Description:*

- normalisation of weights,
- construction of a preference matrix for each criterion,
- results gathering in a global weak preference matrix,
- construction of a strict preference matrix for each criterion,
- results gathering in a global strict preference matrix,
- construction of a global preference matrix from weak and strict preference matrices,
- assessment of input and output flows,
- from input and output flows, assessment of net flows,
- identification of the outclassing relations between alternatives and ranking.

*Note:*

- management of indifference.

#### **2.2.3 MELCHIOR**

*Comparison method:* Choice

*Criteria:* Pseudo-criteria

*Thresholds:* Strict preference, veto.

*Principle:*

The principle of MELCHIOR (Methode d'ELimination et de CHOix Incluant les relations d'ORDre) methodology is OUTCLASSING. Alternatives are compared two by two, criterion by criterion.

*Description:*

- for each couple of alternatives (a, b), exclusion of couples for which veto thresholds is exceeded.
- for each couple of alternatives (a, b), search of criteria supporting and non supporting the statement "a outclass b",
- identification of the outclassing relations between alternatives (masking concept : belief in supporting or non supporting criteria).

*Note:*

- management of indifference and incomparability,
- time consuming method (limitation of the number of alternatives).

#### **2.2.4 BORDA**

*Comparison method:* Ranking

*Criteria:* True criteria.

*Thresholds:* No thresholds.

*Principle:*

BORDA is an Ordinal methodology (methodology only based on the initial ordinal ranking).

*Description:*

- for each criteria, attribution of n points to the best alternative towards the considered criterion, m ( $m < n$ ) points to the second, etc... (these points are called Borda coefficients).

- then, sum of the points obtained by each alternative for all the criteria and ranking of alternatives (the best is the one with the maximum of points).

*Note:*

- compensation between alternatives.
- results depending on the insertion/suppression of alternatives.

### 2.2.5 COPELAND

*Comparison method:* Ranking

*Criteria:* True criteria

*Thresholds:* No thresholds.

*Principle:*

COPELAND is an Ordinal methodology (methodology only based on the initial ordinal ranking).

*Description:*

- for each couple of alternatives (a, b), identification of preference relation (based on the number of criteria favourable to alternatives).
- then, sum of the coefficient obtained by each alternative and ranking of alternatives (the best is the one with the maximum of points).

*Note:*

- compensation between alternatives.

### 2.2.6 ORESTE

*Comparison method:* Choice

*Criteria:* Pseudo-criteria

*Thresholds:* Strict preference, veto.

*Principle:*

ORESTE (Organisation, Rangement Et Synthèse de données relaTionElles) is an Ordinal methodology i.e. methodology only based on the initial ordinal ranking.

*Description:*

- arrangement in order of alternatives according to the decision maker's ranking,
- determination of outclassing relations between alternatives.

*Note:*

- no use of weights on criteria.
- management of indifference.

## 2.3 Summary

The following graph summarises the characteristics of each methodology, in order to help the choice for the best methodology for our objectives.

For this purpose, various decision parameters have been selected:

- type of criteria,
- weights determination,
- problematic,

- management of indifference and incomparability,
- risk of compensation existence,
- ...

Other characteristics can be added to refine the choice:

- subjectivity of the thresholds values,
- time-consuming methodology,
- ...

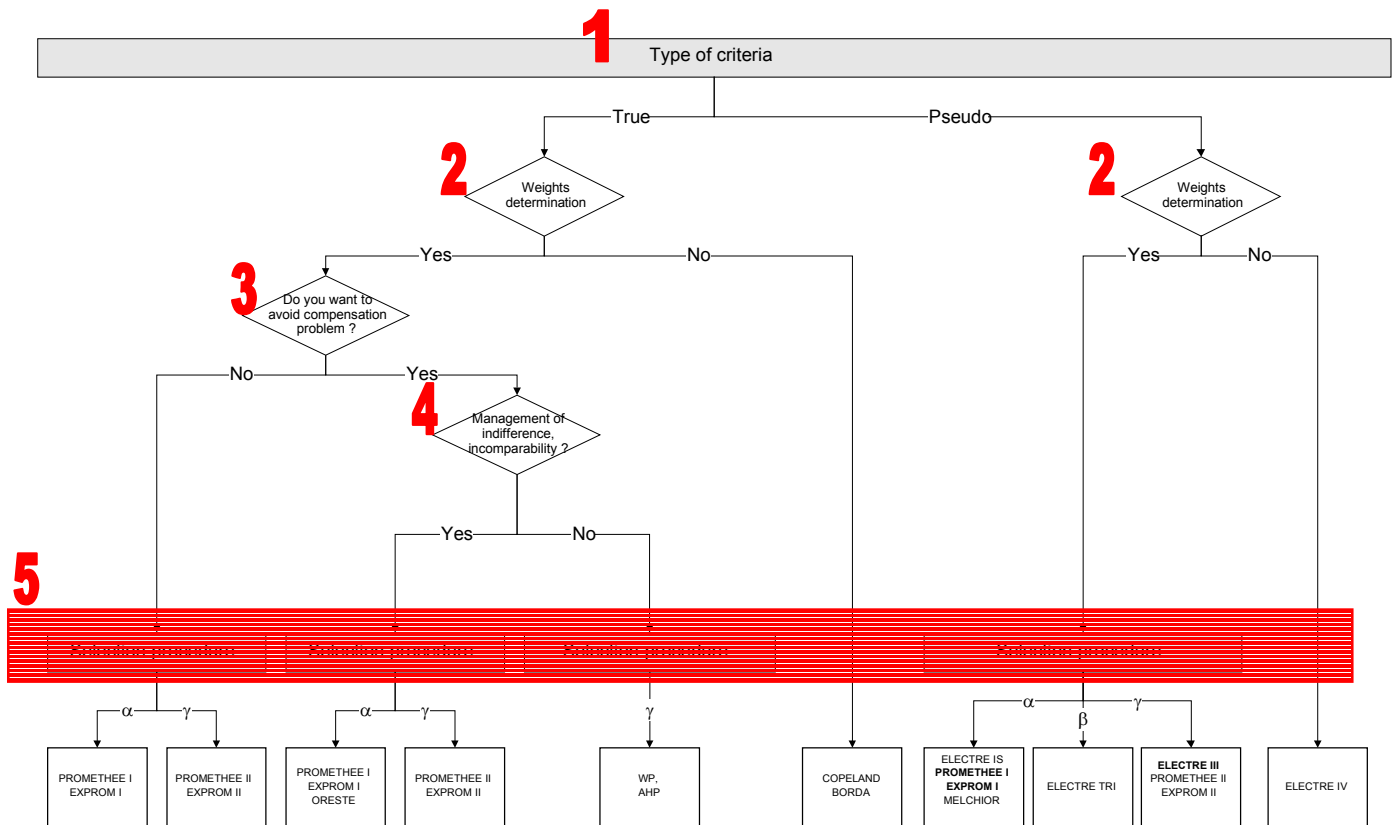

Figure 14: Choice of MADA methodology.

1 – The first decision concerns the type of criteria (chapter 1.4.2).

The question is: “Do you want to use true criteria or pseudo criteria?”

True criteria	Pseudo-criteria
You will only have a “white or black decisions”.	You will be able to include “grey decisions”.
Result: for the considered criteria, preference of one alternative except if alternatives values are equal: $A \gg B$ ; $A=B$ or $A \ll B$	Result: For the considered criteria, strict or weak preferences, indifference: $A \gg B$ ; $A > B$ , $A=B$ , $A < B$ or $A \ll B$

2 – The second decision concerns the weights (chapter 1.5).

The question is: “Do you want to assess the weights?”

YES (assessment of weights)	NO (No assessment)
The user assess the weight according to his preferences.	The weights are not required (based on ordinal relations)

3 – The third question concerns the alternatives (chapter 1.6).

The question is: “Do you want to avoid compensation?”

YES (Avoid compensation problems)	NO (Let compensation be possible)
The method will limit the effect of compensation	An alternative with a very negative assessment on a criterion is counterbalanced by other positive assessments, and can become equal or better than an alternative which has medium values for all the criteria.

4 – The fourth question concerns the alternatives (chapter 1.6).

The question is: “Do you want to manage indifference and incomparability?”

YES (manage indifference and incomparability)	NO (do not manage indifference and incomparability)
The method will limit the effect of compensation	An alternative with a very negative assessment on a criterion is counterbalanced by other positive assessments, and can become equal or better than an alternative which has medium values for all the criteria.

5 – The fifth question concerns the problematic (chapter 1.3).

The question is: “What is your problematic?”

Choice	Sorting	Ranking	Description
We clarify the decision by choosing a subset of alternatives (as small as possible) in order to choose the final alternative. This subset contains optimum and sufficient satisfying alternatives.	We assign the alternatives by categories. Each alternative is assigned to a single category (independent of other categories).	We rank all or some of the alternatives (the most satisfying ones), by assigning a rank of ordering which allows a total or partial ranking.	The problem is correctly stated by describing alternatives and their consequences.

Amongst all these methodologies, three have been chosen. This choice according to the level of requirements fits LIFECON objectives: several methods are suggested, the most useful for the user will be chosen. When applying the methodology, the decision maker will then have several solutions:

- ADDITIVE WEIGHTING which is a very simple method that don't avoid compensation and is not able to take into account indifference (refer to the definitions in chapter 1.6),
- COPELAND which is a very simple method that doesn't require weights definition,
- ELECTRE III, a more complex but more powerful method than the previous two ones.

We will thus have a software with various levels of complexity, a software that could be further developed and adapted according to the user's needs.

Obviously, the more degrees of freedom we leave to the user, the more he needs information and know-how.

We will assume that whenever possible (availability of information):

- we process pseudo-criteria in order to keep a gradation in preference, to manage indifference and incomparability (in some way to take into account the uncertainties on alternatives assessment)<sup>4</sup>,
- we don't accept compensation,
- we prefer outclassing methodologies to weighted methodologies.

---

<sup>4</sup> We can't decide with certainty if the alternative 1 (Service life is 70 years) is better than the alternative 2 (Service life is 80 years) because of the uncertainty on service life assessment.

### 3 Proposed methodology for LIFECON

We propose a methodology that is able to rank the alternatives in order of preference (preference is measured by means of human requirements, lifetime economy, lifetime ecology and cultural criteria). In order to help the user, we have elaborated a framework identifying and explaining the different steps (6 steps).

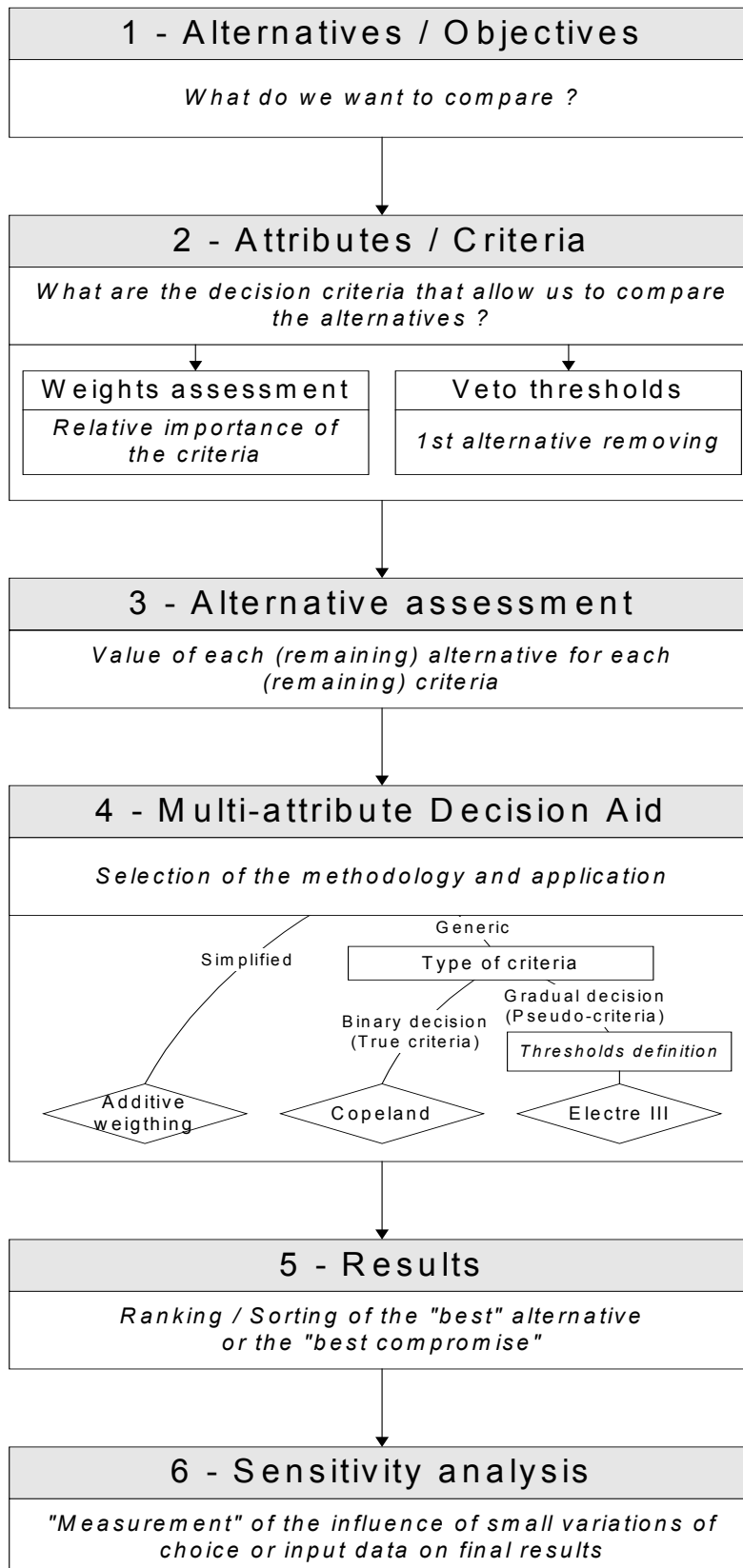

Figure 15: MADA Flow-chart

In the following paragraphs, we will explain and detail each step, before illustrating them in the illustration chapter (4).

### 3.1 General Objectives / Alternatives definition

*“What do we want to do?”*

#### 3.1.1 Network, Object, Module, Component, detail and Material

The first step consists in identifying the level of decision and the phase in the decision process as presented in the Lifecon LMS Handbook.

The decision maker could decide at different phases of maintenance planning:

- Network level: Network level (among all the objects of the stock), which one(s) is (are) identified as having priority for intervention?
- Object level: which part(s) of the object is (are) identified as having priority (e.g. during condition assessment)?
- Module, Component, Detail and Material levels: what are the best solutions to keep or upgrade the level of requirements in performance?

#### 3.1.2 Alternative definition

An alternative is defined accordingly to the objectives. It could be:

- an entity amongst a set of objects (Bridge 1, Bridge 2, ... Bridge i, ..., Bridge n),
- an action amongst a set of maintenance and repair solutions (M&R solutions).

As an example, once identified the need of intervention on an object (by means of the condition assessment of the stock of objects), various actions (strategies for object management) are possible:

- No action
- Maintenance solutions
- Repair solutions
- Restoration solutions
- Rehabilitation solutions
- Modernisation solutions
- Demolition and new construction.

### 3.2 Attributes/Criteria

*“What are the decision criteria that allow us to compare the alternatives?”*

Once the alternatives are defined, we have to identify the various parameters (human, economical, ecological, cultural) characterising alternatives and allowing the comparison, as well as the importance of these parameters (by means of a weight)

To each criterion, corresponds an indicator (measure of the criteria).

As examples, in order to give some guidelines to the users, we propose:

- general requirements criteria,
- techno-economic criteria.

#### **General requirements**

The general requirements usually used are:



	ATTRIBUTES				
	<b>A HUMAN CONDITIONS</b>	<b>B ECONOMY</b>	<b>C ECOLOGY (Economy of nature)</b>	<b>D CULTURE</b>	
<b>CRITERIA</b>	1	Functionality and usability	Investment economy	Raw materials resources economy	Building traditions
	2	Safety	Building costs	Energy resources economy	Life style
	3	Health	Life cycle costs	Pollution of air	Business culture
	4	Comfort		Pollution of soil	Aesthetics
	5			Pollution of water	Architectural styles and trends
	6			Waste economy	Image
	7			Loss of biodiversity	
	8				
	9				

Figure 16: General requirements of Life Cycle Management LMS

**Attributes/criteria selection and definition / Techno-economic level**

As a second step, we refine the selection by using the following techno-economic indicators and factors for fulfilling the primary criteria.

	ATTRIBUTES					
	<b>A Lifetime Usability</b>	<b>B Lifetime Economy</b>	<b>C Lifetime Performance</b>	<b>D Lifetime Environmental impact</b>	<b>E Recovery</b>	
<b>CRITERIA</b>	1	Functioning of spaces	Investment economy	Static and dynamic safety and reliability in use	Non Energetic resources economy	Recycling of wastes in manufacture of materials, components and modules
	2	Functional connections between spaces	Construction cost	Service life	Energetic resources economy	Ability for Selective dismantling
	3	Health and internal air quality	Operation cost	Hygro-thermal performance	Production of pollutants into air	“Reuse-ability” of components and modules
	4	Accessibility	Maintenance cost	Safe quality of internal air	Production of pollutants into water	“Recycling-ability” of dismantling materials
	5	Experienceness	Repair costs	Safe quality of drinking water	Production of pollutants into soil	Hazardous wastes
	6	Flexibility in use	Restoration costs	Acoustical performance		
	7	Maintainability	Rehabilitation costs	Changeability of structures and building services		
	8	Refurbishment-ability	Renewal costs	Operability		

Figure 17.

**Relation between General requirements / Techno-economic level:**

We can establish a link between the general requirements and this techno-economic level. Figure 18 states, for information only, the potential influence of the technico-economic criteria on the general requirements.

	A - HUMAN			B - ECONOMY			C - ENVIRONMENT						D - CULTURE							
	Functionality and usability	Safety	Health	Comfort	Investment economy	Building costs	Life cycle costs	Raw materials resources economy	Energy resources economy	Pollution of air	Pollution of soil	Pollution of water	Waste economy	Loss of biodiversity	Building traditions	Life style	Business culture	Aesthetics	Architectural styles and trends	Image
A - Lifetime Usability	Functioning of spaces	X	X		X											X			X	
	Functional connections between spaces	X	X		X											X			X	
	Health and internal air quality	X	X	X	X					X	X	X				X				
	Accessibility	X	X	X	X													X	X	
	Experienceness																			
	Flexibility in use	X					X	X	X				X	X		X				
	Maintainability	X	X	X	X		X	X	X	X	X	X	X	X						
	Refurbishment-ability	X	X	X	X		X	X	X	X	X	X	X	X					X	
B - Lifetime Economy	Investment economy				X															
	Construction cost					X														
	Operation cost						X													
	Maintenance cost						X													
	Repair costs						X													
	Restoration costs						X													
	Rehabilitation costs						X													
C - Lifetime Performance	Renewal costs						X													
	Static and dynamic safety and reliability in use		X																	
	Service life						X	X	X	X	X	X	X					X		
	Hygro-thermal performance	X	X	X					X									X		
	Safe quality of internal air			X	X					X										
	Safe quality of drinking water			X								X								
	Acoustical performance			X	X															
D - Lifetime Environmental impact	Changeability of structures and building services	X				X	X													
	Operability	X	X	X	X															
	Non Energetic resources economy					X	X					X	X	X	X					
E - Recovery	Energetic resources economy					X		X	X			X	X	X	X					
	Production of pollutants into air		X	X		X			X	X	X		X	X						
	Production of pollutants into water			X		X				X	X		X	X						
	Production of pollutants into soil			X		X				X	X		X	X						
	Recycling of wastes of materials, components and modules					X	X	X		X		X		X					X	
E - Recovery	Ability for Selective dismantling					X	X					X		X				X		
	"Reuse-ability" of components and modules					X	X	X	X	X	X	X		X				X	X	
	"Recycling-ability" of dismantling materials					X	X	X	X	X	X	X							X	
	Hazardous wastes		X	X				X		X	X	X		X						

Figure 18: Relation between General requirements / Techno-economic level

### 3.2.1 Assessment

A method of assessment and a scale is associated to each criteria.

- Some are quantitative criteria and require a unit (Investment cost in M€, Future costs in M€/year).
- Some are qualitative criteria (5-level or 10-level scale) and are thus expressed with a textual description (For instance a 5-level scale could be “very good”, “good”, “medium”, “bad”, and “very bad”).

We also have to define the characteristic called Minimisation (Y/N). Indeed, according to the criteria, the less could be the worst as for quality (Minimisation = Yes) or the best as for cost (Minimisation = No)  
(Refer to chapter 1.4).

### 3.2.2 Weights assessment

The AHP methodology is used within LIFECON. Based on the assessment of the relative importance of each criterion over the others, it clearly takes into account the expert opinion. This method was programmed in an Excel sheet to be easily usable.

## 3.3 Alternative assessment

*“What are the characteristics of the alternatives to be compared?”*

We assess the value of each alternative for each criterion.

## 3.4 Multi-Attribute Decision Aid

*“Which MADA methodology are we going to use?”*

A software was developed to simplify the calculation.

The problem is now totally defined and we can process the information. Each step is automated: from the value of each alternative for each criterion, as well as the weights, the software ranks the alternatives.

### Simplified methodology: Additive weighting

When using the software, a normalisation procedure is needed. They usually give the same results but we recommend the use of the fourth one (in chapter 2.1.1, i.e. division by the square root of the square sum) which is the most powerful normalisation method in some very specific cases.

### Copeland

COPELAND needs no intervention of the user.

### ELECTRE III

#### Thresholds

For ELECTRE III, we need the definition of 3 thresholds: Strict preference threshold, indifference threshold and veto threshold.

Let us take a simple example to illustrate the meaning of each threshold.

	Safety	Health	Investment costs	Future costs	Environmental impacts	Aesthetic
Strict preference threshold	3 <b>b</b>	4	50	15	4	8
Indifference threshold	1	2	20	10 <b>a</b>	2	4
Veto threshold	5	6	30 <b>c</b>	20	6	12

- (a) Indifference threshold means that we don't have preference between two entities for a given criterion, if the difference is lower than this threshold. For instance, if Future Costs (Object 1) = 5 and Future Costs (Object 2) = 10 then Object 1 is equivalent to Object 2 for criteria "Future Costs" ( $10-5 < 10$ ).
- (b) Strict preference threshold means that we prefer one bridge to another one for a given criterion if the difference between assessments is above the threshold. For instance, if Safety (Object 1) = 4 and Safety(Object 2) = 1 then Object 1 is preferred to Object 2 for criteria "Safety" ( $4-1 > 2$ ).
- (c) Veto threshold means that we definitely prefer an alternative if the difference between assessments is above the threshold for at least one criterion. For instance, if Investment costs (Object 1) = 190 and Investment costs (Object 2) = 100 then Object 1 is definitely preferred to Object 2.

### Calculations

Two different calculations have to be done successively:

- downward distillation (chapter 2.2.1.2),
- upward distillation.

Each calculation gives a ranking. The final ranking is the mean of the two rankings.

- If the rankings are equivalent for the two calculations then the final ranking could be considered as the real ranking (the incomparableness indicator given in sheet "Electre III" is equal to 0).
- If the rankings are totally different for the two calculations, then there is a doubt (the incomparableness indicator is far from 0). These alternatives are considered as disruptive elements. They have to be studied more in details (checking the assessment for each criterion, doing pairwise comparisons ...).

## **3.5 Results**

***"What is the best alternative / the worst alternative / the ranking of alternative?"***

MADA methodology leads to the ranking of alternatives by order of preference. It is used to:

- Select the best alternative or possibly the best compromise,
- Select the actions to be applied to a stock of entities given a restricted budget (refer to the handbook).

## **3.6 Sensitivity analysis**

***"Is the decision influenced by the previous choices?"***

### 3.6.1 Generalities

The subjectivity of weights assessment as well as the uncertainty of the assessment of some criteria could lead to a great variation in the results. We have to measure the influence of small variations on the ranking of alternatives. We propose a method that shows the stability of the chosen MADA methodology: a small variation on the weights or on the assessment of some alternatives doesn't involve changes on decisional indicators, and thus ranking of alternatives.

### 3.6.2 Monte-Carlo simulation

We propose a sensitivity analysis based on Monte-Carlo methodology.

In order to "measure" the influence of decision on the results (during subjective steps), we will have a look on:

- the influence of the weights,
- the influence on alternatives assessments (range of value instead of deterministic values).

Note: The second aspect is partially taken into account in ELECTRE methods through thresholds.

With the first MADA analysis, from criteria, weights and alternatives assessments for these criteria, we obtain a ranking of alternatives.

Sensitivity analysis with Monte-Carlo simulation consists then in four steps (Figure 19):

- 1 – Random assessment of the weights or alternatives assessments simulating small variations (e.g.  $\pm 5\%$ ,  $\pm 10\%$  ...),
- 2 – Application of the Multi-Attribute Decision Aid methodology,
- 3 – Ranking of alternatives
- 4 – Statistical analysis of the various rankings.

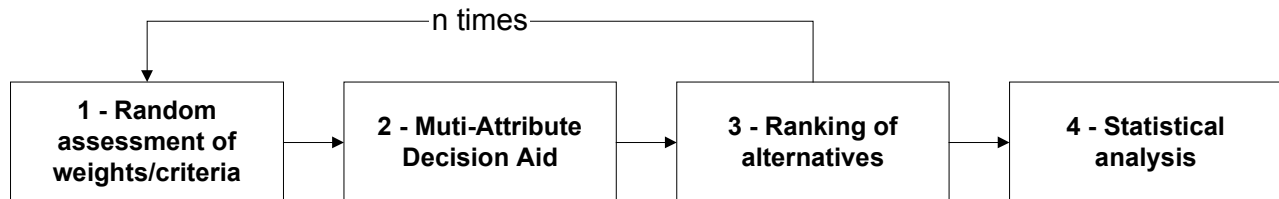

Figure 19: Monte-Carlo simulation

A simulated weight/alternative assessment is obtained by multiplying the initial weight/alternative assessment (given by the user) by a multiplicative factor (variation) modelling small variations.

For instance, an initial weight  $W=30$ , subjected to small variations  $[-10\%, +10\%]$ , will vary in the range  $[30 \times 0,9 ; 30 \times 1,1]$ , i.e.  $[27, 33]$ .

These small variations can be calculated by means of a bounded gaussian distribution defined with:

$$\begin{cases} \text{Mean : } \mu = 1 \\ \text{Standard deviation : } \sigma = \text{variation} / 3 \end{cases}$$

It is then bounded in lower values and upper values respectively by  $(1-\text{variation})$  and  $(1+\text{variation})$ .

The bounds and standard deviation are chosen that way to include 99,7% of the values (99,7% of a Gaussian distribution is included between  $(\mu-3\sigma)$  and  $(\mu+3\sigma)$ ).

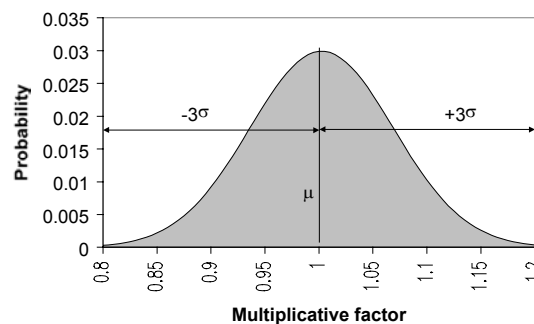

Figure 20: Example of multiplicative factor (Variation 20%)

After  $n$  simulations, we study the various ranking of alternatives and analyse the variations. If some alternatives are classified differently function of the simulations and with similar probabilities, then we could consider that the ranking is sensitive to the input parameters.

For instance, if an alternative is ranked 1<sup>st</sup> for 60% of the simulations and 2<sup>nd</sup> for 40% of the simulations then the results will be considered as sensitive to the input parameters.

Example: refer to chapter 4.6.

## 4 Illustration

### 4.1 Objectives / Alternatives

Let us assume that we have to manage a stock of objects (7 objects to simplify the study).

The objective is to “measure” the importance of each object in order to select the one(s) that require(s) a MR&R action.

### 4.2 Attributes / Criteria

#### 4.2.1 Criteria

Each object is characterised by means of 6 criteria.

The following table gives the characteristics of each criterion.

	Quantit./Qualitat.	Range	Unit	Minimisation <sup>5</sup>
<b>Safety</b>	Qualitative	[0-5]	-	No
<b>Health</b>	Qualitative	[0-5]	-	No
<b>Investment costs</b>	Quantitative	[0-200]	M€	Yes
<b>Future costs</b>	Quantitative	[0-50]	M€/year	Yes
<b>Environmental impacts</b>	Quantitative <sup>6</sup>	[0-10]	-	Yes
<b>Aesthetic</b>	Qualitative	[0-20]	-	No

Figure 21: Criteria definition

#### 4.2.2 Weights

The next step is the identification of the relative importance of the criteria.

We suggest to establish an a priori ranking of the criteria.

For instance:

Aesthetic > Safety > Investment costs > Future costs > Health > Environmental impacts

Then AHP methodology is easier.

The user just has to fill in the yellow cells with values representing the pairwise preferences (according to the values given in Figure 7).

		1	2	3	4	5	6						
		Safety	Health	Investment costs	Future costs	Environmental impacts	Aesthetic						
1	Safety	1	5	2	3	7	1	1	1	1	1	1	1
2	Health	1/5	1	1/4	1/3	1	1/7	1	1	1	1	1	1
3	Investment costs	1/2	4	1	3	6	1/3	1	1	1	1	1	1
4	Future costs	1/3	3	1/3	1	5	1/2	1	1	1	1	1	1
5	Environmental impacts	1/7	1	1/6	1/5	1	1/6	1	1	1	1	1	1
6	Aesthetic	1	7	3	2	6	1	1	1	1	1	1	1

Consistency ratio = 0.04108

Figure 22: AHP methodology for weight definition

<sup>5</sup> YES means that the criterion is desired to be minimised.

<sup>6</sup> This criterion could be partly quantitative, partly qualitative (biodiversity for instance).

Reminder: The consistency ratio has to be lower than 10% (0,1) in order to have consistent comparisons.

The resulting weights are then (column Q on the right of the table in the AHP sheet):

Criteria	Safety	Health	Investment costs	Future costs	Environmental impacts	Aesthetic
Weights	30	5	19	12	4	31

Figure 23: Weights definition

### 4.3 Alternative assessment

For each object, we assess its values (for each criterion).

	Safety	Health	Investment costs	Future costs	Environmental impacts	Aesthetic
<b>Weight</b>	30	5	19	12	4	31
<b>Minimization</b>			Yes	Yes		
<b>Alternative1</b>	4	0	100	20	4	16
<b>Alternative2</b>	3	0	80	30	1	14
<b>Alternative3</b>	2	0	85	30	5	6
<b>Alternative4</b>	4	1	130	25	3	10
<b>Alternative5</b>	1	0	30	35	6	2
<b>Alternative6</b>	1	0	90	30	2	12
<b>Alternative7</b>	2	0	88	20	7	8

Figure 24: Alternative assessment

### 4.4 MADA

The problem is now totally defined and we can process the information. Each step is automated: from the value of each alternative for each criterion, as well as the weights, the software ranks the alternatives.

Launch the MADA macro in the Excel software (Tools menu → Macro → Macros → MADA)

The user interface shown hereafter allows data input in the software (tick the yes if the criteria has to be minimised).

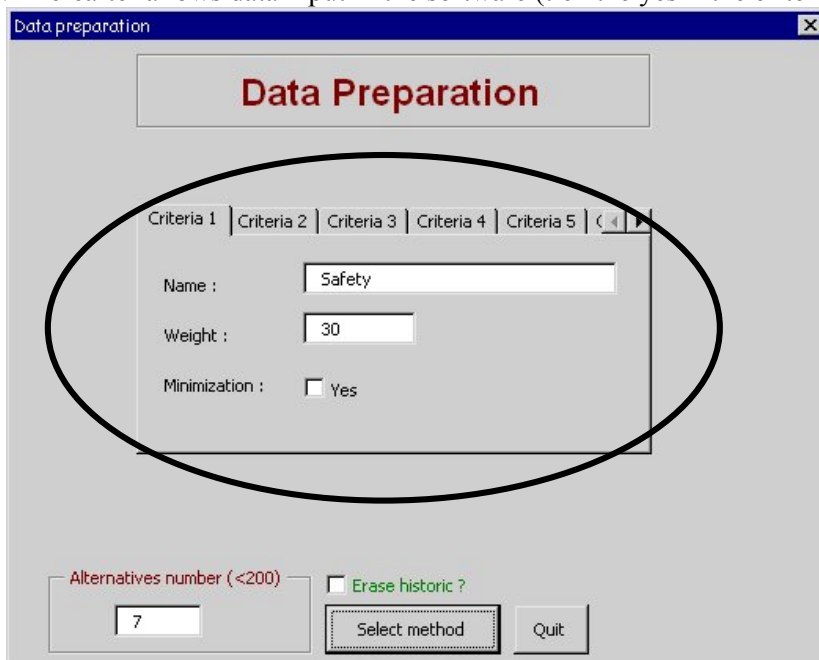
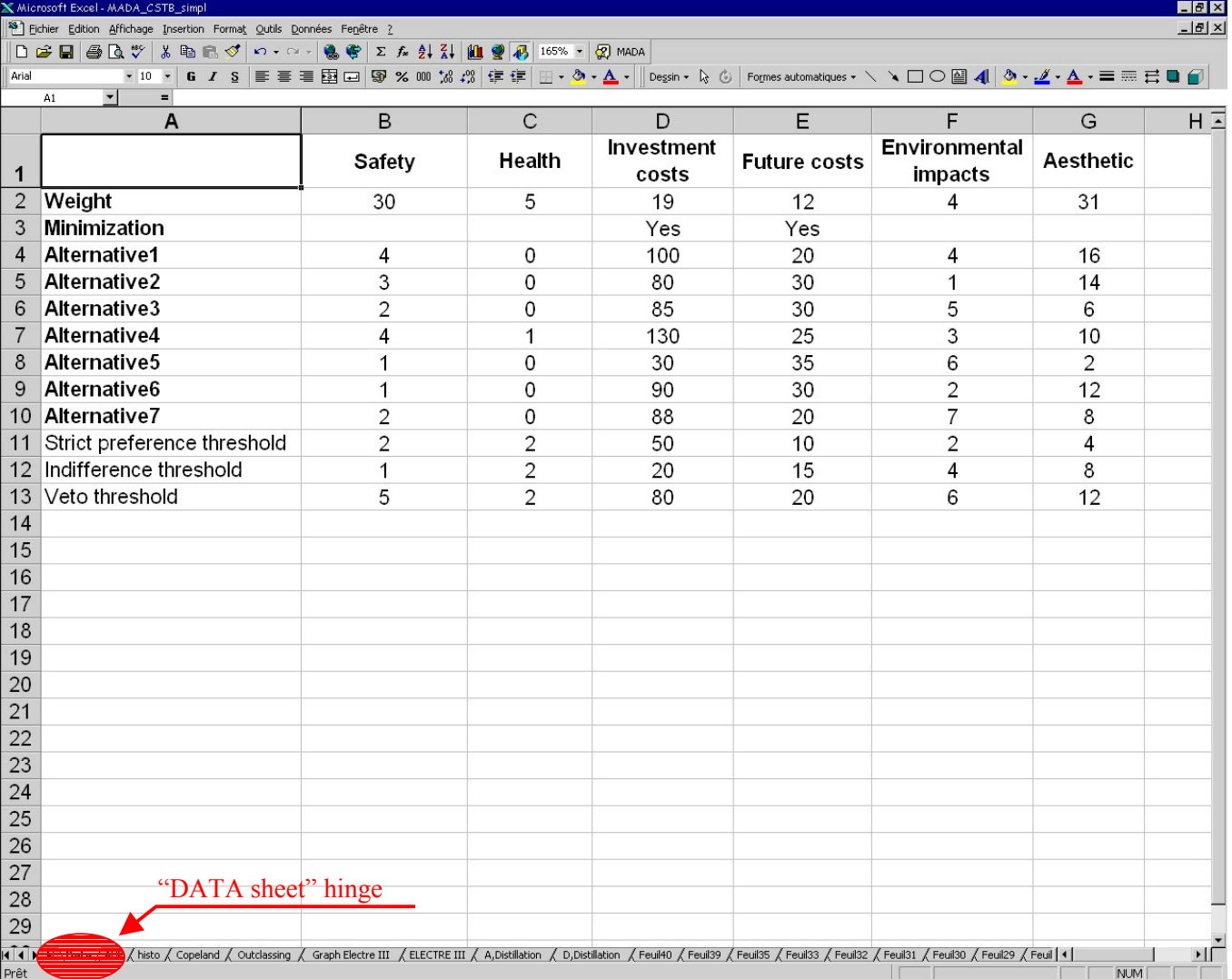

Figure 25: Main MADA software interface

All the information concerning the criteria are stored in the sheet “DATA” (shown hereafter Figure 26).

Note: When starting a new MADA study, the user has to tick the “Erase historic” box. The results stored in the “HISTO” sheet will be deleted.



	A	B	C	D	E	F	G	H
1		Safety	Health	Investment costs	Future costs	Environmental impacts	Aesthetic	
2	Weight	30	5	19	12	4	31	
3	Minimization			Yes	Yes			
4	Alternative1	4	0	100	20	4	16	
5	Alternative2	3	0	80	30	1	14	
6	Alternative3	2	0	85	30	5	6	
7	Alternative4	4	1	130	25	3	10	
8	Alternative5	1	0	30	35	6	2	
9	Alternative6	1	0	90	30	2	12	
10	Alternative7	2	0	88	20	7	8	
11	Strict preference threshold	2	2	50	10	2	4	
12	Indifference threshold	1	2	20	15	4	8	
13	Veto threshold	5	2	80	20	6	12	
14								
15								
16								
17								
18								
19								
20								
21								
22								
23								
24								
25								
26								
27								
28								
29								

Figure 26: Data sheet

This table is not screened automatically. The user has to select the sheet titled “DATA”.

Then click on the *SELECT METHOD* button to select one of the three methods:

- ADDITIVE WEIGHTING in the weighting method category,
- ELECTRE III in the outclassing method category,
- COPELAND in the ordinal method.

#### 4.4.1 Additive weighting

The following interface is opened. As seen previously, a normalisation procedure is needed (Figure 13 page 28). They usually give the same results but we recommend the use of the fourth one which is the most powerful one.



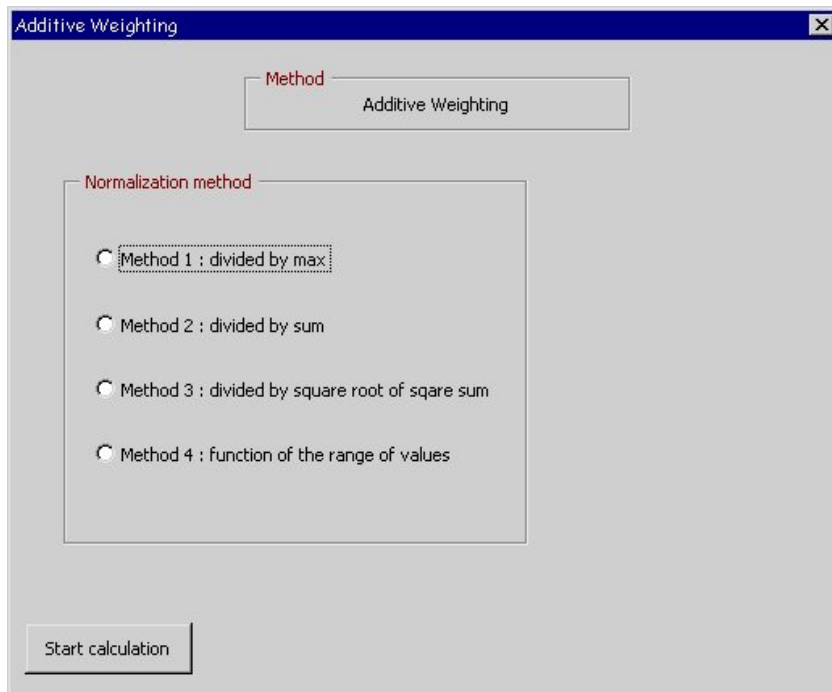

Figure 27: Additive weighting – Choice of the normalisation procedure

The results are given in the following interface.

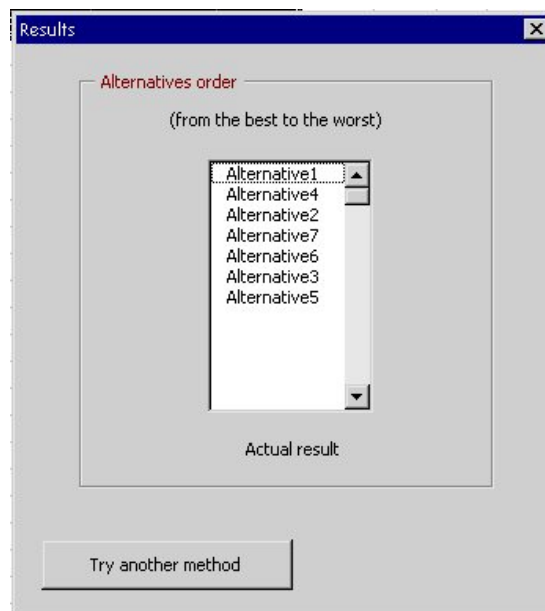

Figure 28: Additive weighting - Results

#### 4.4.2 Copeland

Just START CALCULATION.

The calculation is done and the ranking is stored in the HISTO sheet.

#### 4.4.3 ELECTRE III

##### 4.4.3.1 Threshold definition

For ELECTRE III method, we have seen that various threshold have to be defined.

The user interface shown hereafter allows the threshold input.

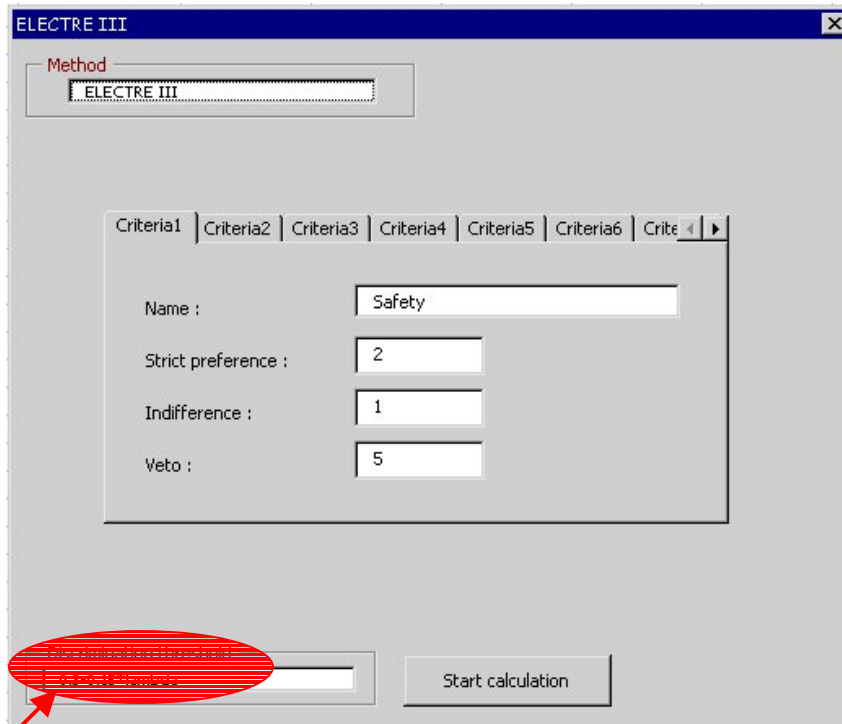

[Refer to list of terms](#)

Figure 29: ELECTRE III – Thresholds definition

This discrimination threshold is a default value that could be left as default.

#### 4.4.3.2 Calculation

Click on the START CALCULATION button.

- first step is Downward distillation
- click again on the START CALCULATION button and then on Ascending distillation.

#### 4.4.3.3 Results

Two types of results are proposed.

The first is table that gives the ranking for the descending and ascending row, as well as the median ranking and the incomparableness index.

Alternatives	Row			Incomparableness
	Descending	Ascending	Median	
Alternative1	1	1	1	0
Alternative2	2	1	1.5	-0.5
Alternative5	3	2	2.5	-0.5
Alternative4	4	4	4	0
Alternative7	6	3	4.5	-1.5
Alternative6	5	5	5	0
Alternative3	6	6	6	0

Figure 30: ELECTRE III – Results

The second is a plotting of the previous results (Figure 31).

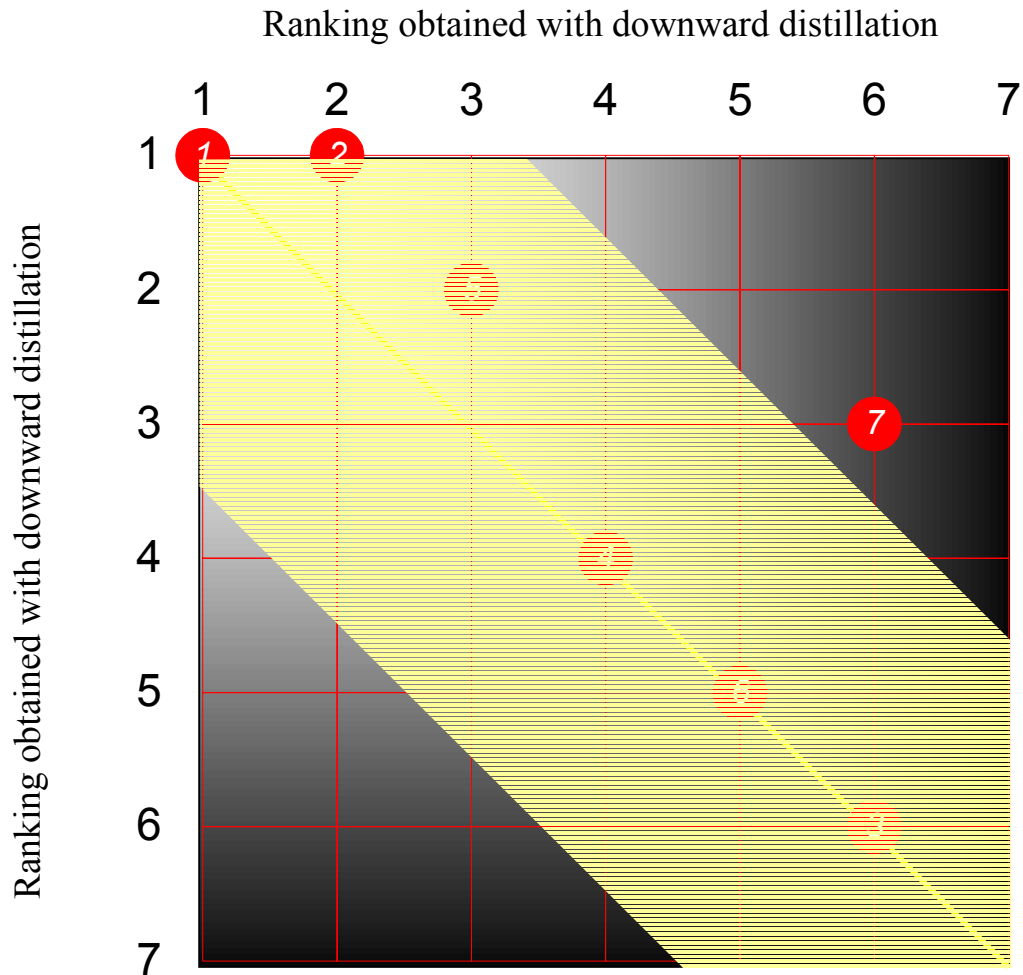

*Figure 31: ELECTRE III - Plotting*

The alternatives located on the left upper corner are the best ones (ranked one for the two calculations). The more the dots go away (to the right lower corner of the graph), the worse is the alternative.

The alternative numbered 7 is clearly far from the diagonal (yellow line). Outside the yellow zone, there is a difference of 2 ranks between downward (medium ranking) and upward distillations (worst ranking). Alternative 7 is then a disruptive element, and should be studied more deeply.

#### 4.5 Results

All the results are stored in a sheet titled HISTO. It gives the ranking for the three methods (and makes the distinction between the four different normalisation methods).

Additive Weighting Arrangement Problems Function of the range of utilities	ELECTRE III Ranking Problems Not needed (Outclassing method)	Copeland Arrangement Problems Not needed
Alternative1	Alternative1 (1, 1)	Alternative1
Alternative4	Alternative2 (2, 1)	Alternative4
Alternative2	Alternative5 (3, 2)	Alternative2
Alternative7	Alternative4 (4, 4)	Alternative7 ex
Alternative6	Alternative7 (6, 3)	Alternative3
Alternative3	Alternative6 (5, 5)	Alternative5
Alternative5	Alternative3 (6, 6)	Alternative6 ex

Figure 32: HISTO sheet

Note:

For the Copeland method, the results indicate “placed equal” alternatives (Alternatives 2 and 7, as well as 5 and 6 have to be considered as equivalent).

The results are in this example rather different for the various methods.

Searching for the commonalities between methods, we can draw a graph (Figure 33) showing the average ranking obtained with the three methods for each alternative (blue cross), as well as the minimum and maximum rankings (red line).

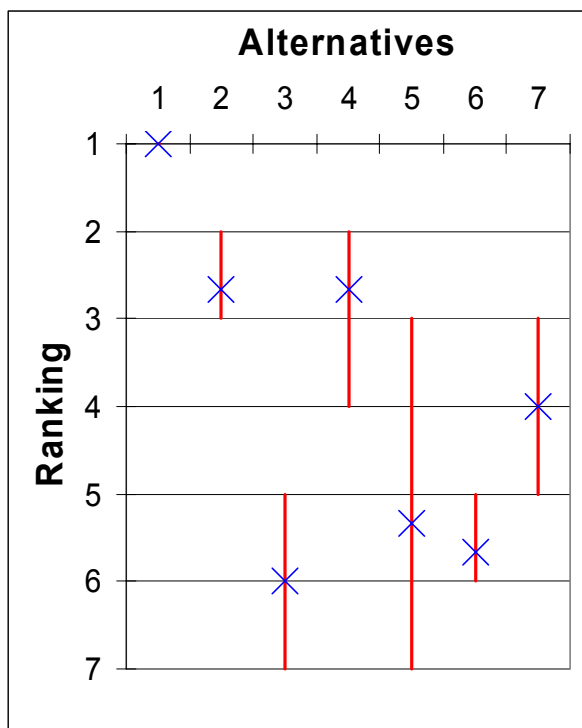

Figure 33: Comparison of the results

We identify that:

- alternative 1 is clearly the best one,
- alternatives 2 and 4 are acceptable, and seem to be secondly ranked (but we could not decide if one is better than the other one),
- alternative 7 is a “medium” alternative,
- alternatives 3 and 6 are bad alternatives.

As for the alternative 5, it's difficult to obtain information from the MADA procedure since it could be medium or bad alternative.

#### 4.6 Sensitivity analysis

This part was not totally developed in the LIFECON project. We will illustrate the sensitivity analysis with a basic example and give the code used to process this sensitivity analysis (MATLAB code in APPENDIX 1 and APPENDIX 2).

For instance, we have performed a sensitivity analysis with additive weighting methodology, first looking at the influence of a small variation on the weights, and second a small variation on the assessments.

##### 4.6.1 Variation of the weights

Using the Matlab code given in the APPENDIX 1 with variations of 20% and 50% on the weights, we obtain the following results (Figure 34 and Figure 35).

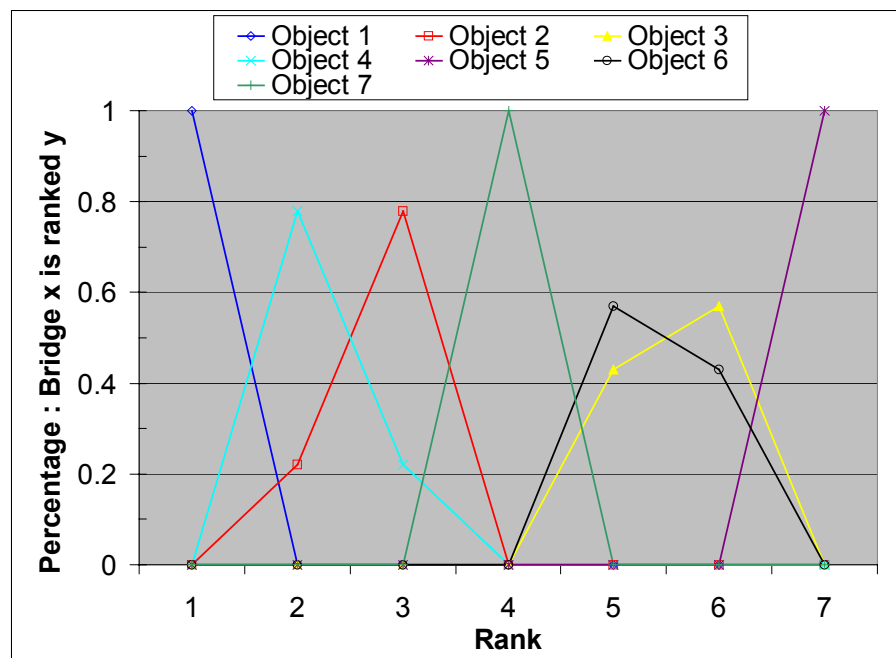

Figure 34: Additive weighting - Weights +/-20%

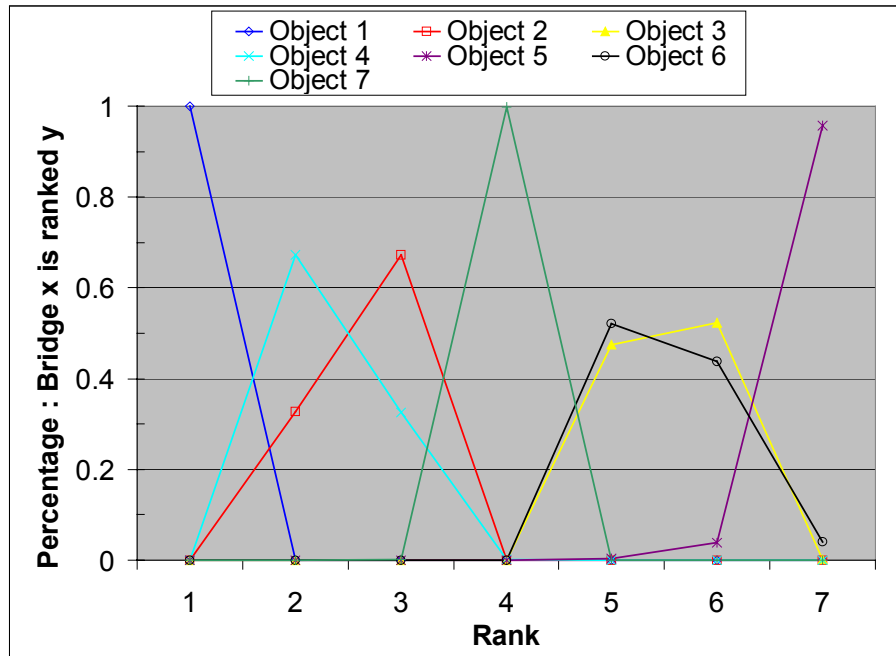

Figure 35: Additive weighting - Weights +/-50%

For variations of 20% or 50%, we notice that the object 1 is always ranked number 1, the object 7 is always ranked 4, the object 5 is always ranked 7 (95% of the simulations for a 50% variation). The ranking is then very reliable. Concerning the objects 2 and 4 on the one hand, and objects 3 and 6 on the other hand, we can't be sure of the ranking for a 50% variation.

	Rank 2	Rank 3
Object 2	33%	67%
Object 4	67%	33%

	Rank 6	Rank 7
Object 3	48%	52%
Object 6	52%	44%

Note: Object 6 is ranked 7 in 4% of the simulation.

The final ranking is then:

Rank	1	2	3	4	5	6	7
Object	1	4 or maybe 2	2 or maybe 4	7	3 or 6	3 or 6	5

#### 4.6.2 Variation of the assessments

The same reasoning can be done for variations of assessments using the Matlab code given in APPENDIX 2.

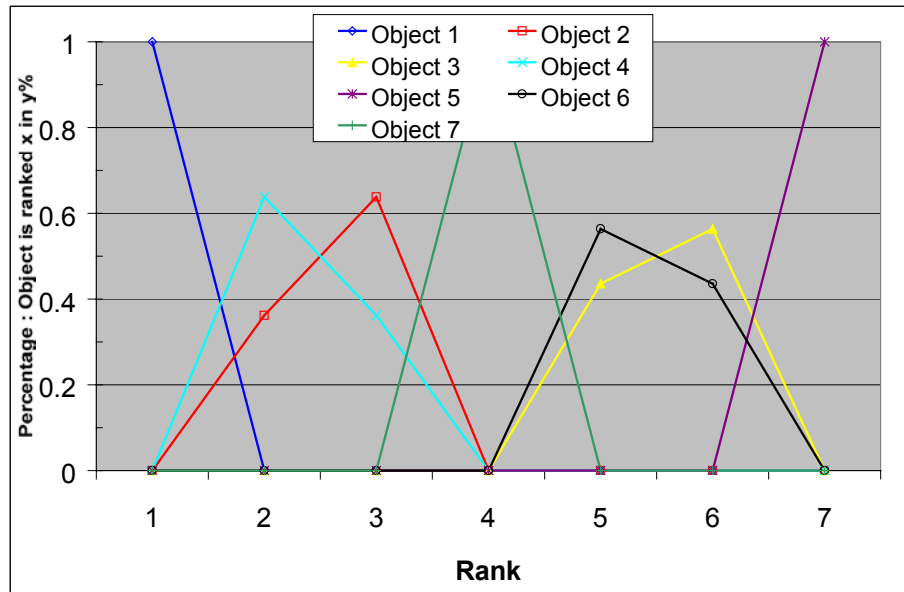

Figure 36: Additive weighting - Assessments +/-10%

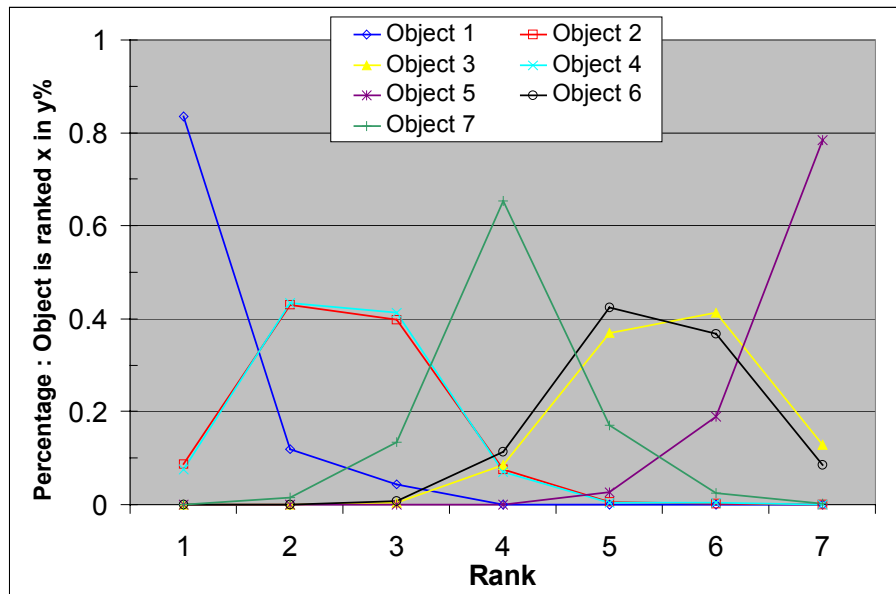

Figure 37: Additive weighting - Assessments +/-30%

In case of variations of 10%, the results are rather stable. We just have uncertainty on the ranking of objects 4 and 2 on the one hand (Indecision 63%/37% for being ranked 2 or 3), and objects 6 and 3 on the other hand (Indecision 58%/42% for being ranked 5 or 6).

In case of variations of 30%, the results are:

Rank	1	2	3	4	5	6	7
<b>Object 1</b>	1 83,6%	2 43,0%	4 41,2%	7 65,4%	6 42,4%	3 41,2%	5 78,4%
<b>Object 2</b>	2 8,8%	4 43,0%	2 39,8%	6 11,4%	3 37,0%	6 36,8%	3 12,8%
<b>Object 3</b>	4 7,6%	1 12,0%	7 13,4%	3 8,6%	7 17,0%	5 19,0%	6 8,6%
<b>Object 4</b>		7 2,0%	1 4,4%	2 7,6%	5 2,6%	7 2,4%	7 0,2%
<b>Object 5</b>			6 0,8%	4 7,0%	2 0,6%	4 0,4%	
<b>Object 6</b>			3 0,4%		4 0,4%	2 0,2%	

Figure 38: Ranking probabilities

We thus can conclude that the final results are:

<b>Rank</b>	<b>1</b>	<b>2</b>	<b>3</b>	<b>4</b>	<b>5</b>	<b>6</b>	<b>7</b>
Object	1	2 or 4	4 or 2	7	6 or 3	3 or 6	5

In this chapter, we have just given some guidelines to the user in order that he is able to do a basic sensitivity analysis. The aim of this study is to control the influence of the user's choices (concerning weights and assessments) on the final results. Such study gives more confidence in the results.



## 5 References

ASTM (1995) *Standard Practice for Applying the Analytic Hierarchy Process to Multiattribute Decision Analysis of Investments Related to Buildings and Building Systems*. ASTM Designation E 1765-95.

ASTM Standard: E 1765-98: Standard Practice for Applying Analytical Hierarchy Process (AHP) to Multiattribute Decision Analysis of Investments Related to Buildings and Building Systems

ASTM (1995) *Standard Practice for Applying the Analytic Hierarchy Process to Multiattribute Decision Analysis of Investments Related to Buildings and Building Systems*. ASTM Designation E 1765-95.

POMEROL, J.-C. BARBA-ROMERO, S. (1993), « *Choix multicritère dans l'entreprise* », Hermes.

MAYSTRE, L. Y. PICTET, J. SIMOS, J. (1994), « *Méthodes multicritères ELECTRE* », Collection Gérer l'environnement vol 8, Presses polytechniques et universitaires Romandes.

NORRIS, G. A. and MARSHALL, H. E. (1995) “*Multiattribute Decision Analysis Method for Evaluating Buildings and Building Systems*”. NISIR 5663, National Institute of Technology, Gaithersburg, MD.

ROOZENBURG, N and EEKELS, J. (1990) “*EVAD, Evaluation and Decision in Design. (Bewerten und Entscheiden beim Konstruieren)*”. Schriftenreihe WDK 17, Edition HEURISTA: Zürich.

ROY, B. (1985), « *Méthodologie Multicritère d'Aide à la Décision* », vol.1, Collection Gestion, Editions Economica.

SARJA, Asko, *Integrated Life Cycle Design of Structures*. 142 pp. Spon Press, London 2002. ISBN 0-415-25235-0.

**APPENDIX 1**

MATLAB code for the sensitivity analysis

Additive weighting method- Influence of the variation of the weights

Clear all;

```

%-----
% FIRST MODULE: PROBLEM DEFINITION
%-----

% Criteria weights
w=[30,5,19,12,4,31];

% Minimisation (1 -> minimisation / 0 -> maximisation)
m=[0,0,1,1,0,0];

% Matrix with assessments
assessment = [4      0      100      20      4      16 ; 3      0
              80     30      1      14 ; 2      0      85      30
              5      6 ; 4      1      130      25      3      10 ; 1
              0      30      35      6      2 ; 1      0      90
              30     2      12; 2      0      88      20      7
              8];

% e = error (10%->e=0.1)
e = 0.5;
% n = number of iterations
n = 500;

% Number of alternatives (anb) and criteria (cnb)

anb=size(assessment,1);
cnb=size(assessment,2);

%-----
% SECOND MODULE: RANDOM WEIGHTS
%-----

for i=1:n
    for j=1:cnb
        w_sim(i,j)=w(j)*(1+(2*rand-1)*e);    % Creation of a matrix with all simulated weights
    end
end

%-----
% THIRD MODULE: AHP METHOD
%-----

```

**% Normalisation of weights**

```

for i=1:n
    for j=1:cnb
        w_sim_norm(i,j)=w_sim(i,j)/sum(w_sim(i,:));
    end
end

```

**% Normalisation and minimisation of alternatives**

```

for i=1:cnb
    minimum(i)=min(assessment(:,i));
    maximum(i)=max(assessment(:,i));
end

for i=1:anb
    for j=1:cnb
        assess_norm(i,j)=(assessment(i,j)-minimum(j))/(maximum(j)-minimum(j));
    end
end

for i=1:cnb
    if m(i)==1
        for j=1:anb
            assess_norm(j,i)=1 - assess_norm(j,i);
        end
    end
end

```

**% Agregation sum(weights\*assessment)**

```

for i=1:n
    for j=1:anb
        temp=0;
        for k=1:cnb
            temp=temp+w_sim_norm(i,k)*assess_norm(j,k);
        end
        res(i,j)=temp;
    end
end

```

**% Increasing order (rank)**

```

for i=1:n
    vect=res(i,:);
    for j=1:floor((anb+1)/2)
        mini=min(vect);
        maxi=max(vect);
        order(i,anb+1-j)=mini;
        order(i,j)=maxi;
    end
end

```

```
v=1;
test1=0; test2=0;
for k=1:anb+2-2*j
    if vect(k)==mini | vect(k)==maxi
        test1=1;
    else
        tem(v)=vect(k);
        v=v+1;
        test2=1;
    end
end
if test1==1
    vect=mini;
end
if test2==1
    clear vect;
    vect=tem;
    clear tem;
end
end
end
```

#### % Assessment of rank

```
for i=1:n
    for j=1:anb
        for k=1:anb
            if res(i,j)==order(i,k)
                rank(i,j)=k;
            end
        end
    end
end
end
```

**APPENDIX 2**

MATLAB code for the sensitivity analysis

Additive weighting method - Influence of the variation of the assessments

Clear all;

```

%-----
% FIRST MODULE: PROBLEM DEFINITION
%-----

% Criteria weights
w=[30,5,19,12,4,31];

% Minimisation (1-->minimisation 0-->maximisation)
m=[0,0,1,1,0,0];

% Matrix with assessments
assessment = [4      0      100      20      4      16 ; 3      0
              80      30      1      14 ; 2      0      85      30
              5      6 ; 4      1      130      25      3      10 ; 1
              0      30      35      6      2 ; 1      0      90
              30      2      12; 2      0      88      20      7
              8];

% e = error (10%-->e=0.1)
e = 0.1;
% n = number of iterations
n = 500;

% Number of alternatives (anb) and criteria (cnb)

anb=size(assessment,1);
cnb=size(assessment,2);

%-----
% SECOND MODULE: WEIGHTS
%-----

% Normalisation of weights
for i=1:cnb
    w_norm(i)=w(i)/sum(w(:));
end

%-----
% THIRD MODULE: AHP METHOD
%-----

```

```
for nb=1:n
```

```
    % Random assessment of alternatives
```

```
    for i=1:anb
        for j=1:cnb
            assessment_sim(i,j)=assessment(i,j)*(1+(2*rand-1)*e);
        end
    end
```

```
    % Normalisation and minimisation of alternatives
```

```
    for i=1:cnb
        minimum(i)=min(assessment_sim(:,i));
        maximum(i)=max(assessment_sim(:,i));
    end
```

```
    for i=1:anb
        for j=1:cnb
            assessment_sim_norm(i,j)=(assessment_sim(i,j)-minimum(j))/(maximum(j)-minimum(j));
        end
    end
```

```
    for i=1:cnb
        if m(i)==1
            for j=1:anb
                assessment_sim_norm(j,i)= 1 - assessment_sim_norm(j,i);
            end
        end
    end
```

```
    % Agregation sum(weights*assessment)
```

```
    for j=1:anb
        temp=0;
        for k=1:cnb
            temp=temp+w_norm(k)*assessment_sim_norm(j,k);
        end
        res(nb,j)=temp;
    end
```

```
    % Increasing order (rank)
```

```
    vect=res(nb,:);
    for j=1:floor((anb+1)/2)
        mini=min(vect);
        maxi=max(vect);
        order(nb,anb+1-j)=mini;
        order(nb,j)=maxi;
    end
```

```
v=1;
test1=0; test2=0;
for k=1:anb+2-2*j
    if vect(k)==mini | vect(k)==maxi
        test1=1;
    else
        tem(v)=vect(k);
        v=v+1;
        test2=1;
    end
end
if test1==1
    vect=mini;
end
if test2==1
    clear vect;
    vect=tem;
    clear tem;
end
end
```

**% Assessment of rank**

```
for j=1:anb
    for k=1:anb
        if res(nb,j)==order(nb,k)
            rank(nb,j)=k;
        end
    end
end
end
```

end

European Community. Fifth Framework Program: GROWTH

RDT Project: Life Cycle Management of Concrete Infrastructures for Improved Sustainability: LIFECON



## **PART II:**

# **Quality Function Deployment (QFD)**

**Author: Asko Sarja**

## Keywords

QFD, lifetime, asset management, optimisation, decision making, requirements, properties, weights

## Abstract

Quality Function Deployment (QFD) method is related to methods of linear programming which have been developed in 1950's and were widely used in 1960's in product development of industry. In different fields of application appeared a need to modify the basic linear programming methodology for specific needs of each application field. Results of these applications are all the methods mentioned above: QFD, MADA and RAMS.

QFD provides an empty matrix "House of Quality", which will be filled with Requirements and their Weighting Factors in the rows along the left hand side, and Performance Properties of the actual alternative in the columns along the top portion. The centre describes the matrix-relationship of requirements and corresponding solutions. The importance measures (weight factors) are at the bottom, and the right hand side of the box shows the evaluation of competing alternatives.

QFD method basically means handling the Requirements and Properties, analysing their interrelations and correlations as well as their weights and finally optimising the LCQ (Life Cycle Quality) Properties and selecting between alternative solutions of asset management strategies or MR&R plans, designs, methods and products. This is why QFD can be applied in many variables, depending on the characteristic aims and contents of each application. The correlations and weights can not usually be estimated with exact calculations, but they must be estimated with expertise knowledge, client questionnaires, long term experiences and expectations on the future trends. The weights can be expressed in different scales, for example on the range of 0 (no importance) to 10 (extremely important). As final results of the matrix calculations the weight factors of Requirements and Properties are normalised.

In Lifecon LMS QFD can be used for following purposes:

- Identifying Requirements of owner, user and society
- Interpreting and aggregating functional Requirements into primary Performance Properties
- Interpreting the Performance Properties into Technical Specifications of the actual object
- Optimising the Performance Properties and Technical Specifications in comparison to Requirements
- Selection between different design and repair alternatives and
- Selection between different products

QFD can be used on all levels of Lifecon LMS system:

- Network level: prioritising the requirements of users, owners and society, strategic optimisation and decision making between alternative MR&R strategies
- Object level: ranking of priorities between objects, optimising and decision between MR&R alternatives, technologies, methods and products
- Module, Component and Detail/Materials levels: refined optimising and decision between MR&R alternatives, technologies, methods and products

The general content and use of QFD is described in this Lifecon Deliverable D2.3, while a specific Lifecon LMS application for MR&R (Maintenance, Repair, Rehabilitation) planning is described in Lifecon Deliverable D5.1.

## List of Contents

### Author of Part II: Asko Sarja

PART II: .....	65
Quality Function Deployment (QFD) .....	65
Abstract .....	66
List of Contents .....	67
6 QFD method in the performance based management planning procedure of Lifecon LMS... 68	
6.1 QFD in performance based and optimising planning procedure .....	68
7 Principles of Quality Function Deployment Method .....	70
7.1 Short history of the QFD method .....	70
7.2 General use of QFD method .....	70
7.3 Generic description of QFD method .....	71
8 Procedure of QFD in Lifecon LMS .....	73
8.1 Alternative applications .....	73
8.2 Phases of the QFD procedure .....	73
8.3 Requirements and Properties in Lifecon LMS .....	74
8.3.1 Hierarchy of the requirements and properties .....	74
8.3.2 Performance Requirements and Properties .....	75
8.4 Aggregation of life cycle performance Requirements and Properties .....	78
8.4.1 Aggregation methods .....	78
8.4.2 Aggregation procedures .....	79
8.5 Selection of the Primary Requirements and Properties .....	83
9 IT support for QFD method .....	84
9.1 Direct Excel applications .....	84
9.2 Commercial programs .....	84
10 References .....	85
APPENDIX: Examples on the QFD procedure .....	87

## 6 QFD method in the performance based management planning procedure of Lifecon LMS

### 6.1 QFD in performance based and optimising planning procedure

The integrated and predictive lifetime management planning methodology is aiming at regulating optimisation and guaranteeing the **lifetime quality** of infrastructure. The *lifetime quality* means the capability of the object to fulfil the requirements of users, owners and society over entire life cycle, in relation to human conditions, economy, cultural compatibility and ecology. These requirements and criteria can be modelled with technical performance properties, which again can be concretised into alternative solutions with the aid of technical specifications of the objects, as presented in Figure 39.

The phases of performance based planning and design are:

1. **Analysis and optimisation** of the **functional** requirements of the owner, user and society
2. **Aggregation** of *Individual Requirements* into *Primary Requirements*
3. **Analysis and optimisation** of the **performance properties** of the object, structural system, module, component, detail or material, basing on the functional requirements
4. **Specification** of the **technical properties** of the alternative solutions of planning, design, method or product, basing on the performance properties.

This procedure scheme is as presented in Figure 39.

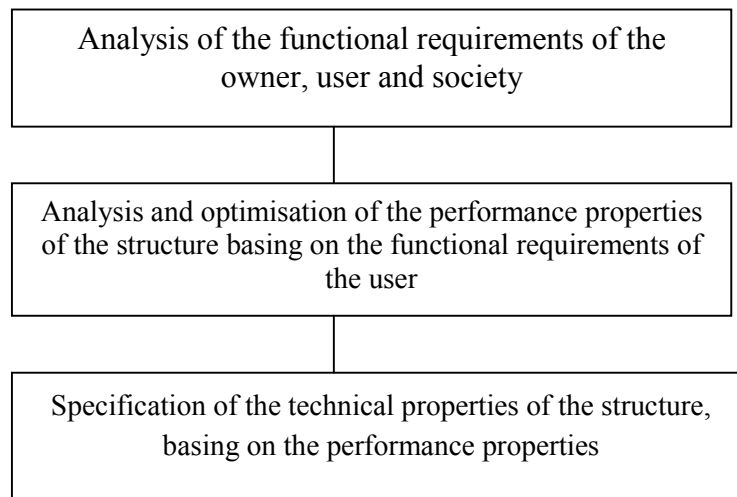

Figure 39. Procedure scheme from functional requirements through performance parameters into technical specifications.

Methods, which can be used in this procedure, are:

1. QFD: Quality Function Deployment
2. RAMS: Reliability, Availability, Maintainability and Safety analysis [Lifecon Deliverable D5.1]

3. MADA: Multiple Attribute Decision Aid [Lifecon Deliverable D2.3, Part I]
4. Risk analysis [Lifecon Deliverable D2.3, Part III]
5. Markovian Chain method [Lifecon Deliverable D2.2]

In all of these methodologies can be applied the reliability principles regarding to mechanical (static and dynamic) reliability, durability reliability and obsolescence reliability [Lifecon Deliverable D2.1]. Each of these methods have pros and cons, which affect in different application fields. This is why we present these alternative methods as components of the open Lifecon LMS for individual choices.

Often two or more of these methods can be also combined. The combination of QFD and RAMS is presented in Lifecon Deliverable D5.1, where QFD is serving as a quantitative method and RAMS as a qualitative and ranking method in relation those factors, which cannot be quantified.

QFD (Quality Function Deployment) is a tool for optimisation and decision making, which has a strong numerical character thus serving especially following functions:

- analysis and weighting of the requirements
- optimisation of solutions with a choice between different modifications of the solution
- choice between alternatives of plans, designs, methods or products.

## 7 Principles of Quality Function Deployment Method

### 7.1 Short history of the QFD method

Quality Function Deployment (QFD) method is related to methods of linear programming which have been developed in 1950's and were widely used in 1960's in product development of industry. In different fields of application appeared a need to modify the basic linear programming methodology for specific needs of each application field. Results of these applications are all the methods mentioned above: QFD, MADA and RAMS.

In current formulation QFD was developed in Japan and it was first used in 1972 by Kobe Shipyard of Mitsubishi heavy industries in 1972 [1]. QFD has been increasingly used in Japan and since 1980's also in USA and Europe and world wide. Mainly the use until now has been in mechanical and electronics industry, but applications exist also in construction sector. In industrial engineering, manufacturing companies have successfully applied Quality Function Deployment to determine customers' needs for the features of the product into design at its early stages of development, to integrate design of products and their related processes, and to consider all elements of the product life cycle [2]. Customer-oriented “champion products” may also be priced higher than their competitors, and still become as market leaders. QFD has been little applied in construction. Examples have been reported for example from Japan, United States, Finland, Sweden and Chile, which show its potential also in building design, construction planning and asset management [ [3], [4], [5], [6] ] .

### 7.2 General use of QFD method

QFD can be applied both on strategic level and on operational level of construction and asset management organisations. The strategic development of the owner, user, construction or management organisation may have following focuses:

- strategic planning of the organisation
- product development (product can be an entity: house, office, road, bridge, tunnel etc.), or a more detailed product (module, component or material)

In practical construction or repair process QFD has to be applied in four stages:

1. Analysis of the Requirements of the client, and their weights of importance.
2. Choice of the Properties of the Product (e. g. a house, office, bridge, railway, tunnel etc.) basing on the Requirements and their weights, which have been resulted from stage 1.
3. Analysis of the Requirements of the Product for the Production Process.
4. Analysis of the Requirements of the Production Process for the Product.

This means, that interactions between all phases of the planning, design and production are analysed and optimised with the QFD method. As results of the first stage are the weights of *Requirements*. Result of the second stage is a list of the *Properties* of the *Product*, and the weights of these *Properties*. Third stage results in a list of *Requirements* of the product and their weights for a fluent production process. This stage consists of analysis of correlations between focused phases of the production process and the properties that the product requires from these phases. Fourth stage includes analysis on, what the production process and its phases require

from the product. This leads into an iterative optimisation between the properties of the product and the properties of the production process. The Requirements from the first stage serve as constraints in this optimisation but they may have to be slightly modified, if the iteration does not converge otherwise. An example of this procedure is presented in the repair planning examples of Lifecon deliverable D5.1, where QFD is used in combination with RAMS (reliability, availability, maintainability, safety) methodology. The words in the title: RAMS include the requirements of the properties of the product and manufacturing process for the alternative repair technologies or materials. This in fact is a mix of points 3 and 4 above [D5.1].

QFD can be used in planning and design on quite different ways, for example:

- for interpreting any Requirements into Specifications, which can be either Performance Properties or Technical Specifications.
- QFD can serve as an optimising or selective linking tool between Requirements, Performance Properties and Technical Specifications.
- QFD can be used both at product development, at design of individual civil infrastructures or buildings, and at maintenance and repair planning.

Simply the QFD method means building of a matrix between Requirements and Performance Properties or Technical Specifications. Usually the Performance Properties are serving only as a link between Requirements and Technical Specifications, why the Performance Properties sometimes are not treated with QFD method. Additionally weighting factors of Requirements and Technical Specifications as well as correlations between Requirements and Technical Specifications are identified and determined numerically. As a computer tool is Excel program very suited for this calculation, as it has been used in examples [D5.1].

### 7.3 Generic description of QFD method

In practical planning and design the application shall be limited into few key Requirements and key Specifications in order to maintain good control of variables and in order not to spend too much efforts for secondary factors. At product development some more detailed application can be used. A model table “house of quality” is presented in Figure 40.

QFD provides an empty matrix "House of Quality", as presented in Figure 40. This matrix will be filled with Requirements and their Weighting Factors in the rows along the left hand side, and Performance Properties of the actual alternative in the columns along the top portion. The centre describes the matrix-relationship of requirements and corresponding solutions. The importance measures (weight factors) are at the bottom, and the right hand side of the box shows the evaluation of competing alternatives.

The correlations and weights can not usually be estimated with exact calculations, but they must be estimated with expertise knowledge, client questionnaires, long term experiences and expectations on the future trends. The weights can be expressed in different scales, for example on the range of 0 (no importance) to 10 (extremely important). As final results of the matrix calculations the weight factors of Requirements and Properties are normalised, as shown in examples of the attached APPENDIX and in Lifecon Deliverbale [D5.1].

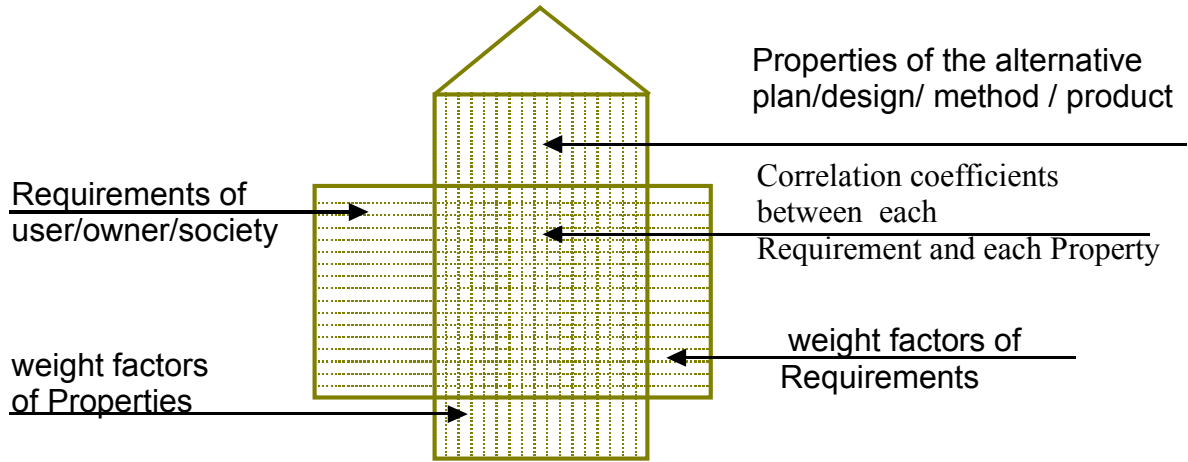

Figure 40. House of Quality [[1], [2] ,[3], [4], [5] ].



## 8 Procedure of QFD in Lifecon LMS

### 8.1 Alternative applications

QFD method basically means only handling the Requirements and Properties, analysing their interrelations and correlations as well as their weights and finally optimising the LCQ (Life Cycle Quality) Properties and selecting between alternative solutions of asset management strategies or MR&R plans, designs, methods and products. This is why QFD can be applied in many variables, depending on the characteristic aims and contents of each application.

In Lifecon LMS QFD can be used for following purposes:

- Identifying functional Requirements of owner, user and society
- Interpreting and aggregating functional Requirements into primary Performance Properties
- Interpreting the Performance Properties into Technical Specifications of the actual object
- Optimising the Performance Properties and Technical Specifications in comparison to Requirements
- Selection between different design and repair alternatives and
- Selection between different products

QFD can be used on all levels of Lifecon LMS system:

- Network level: prioritising the requirements of users, owners and society, strategic optimisation and decision making between alternative MR&R strategies
- Object level: ranking of priorities between objects, optimising and decision between MR&R alternatives, technologies, methods and products
- Module, Component and Detail/Materials levels: refined optimising and decision between MR&R alternatives, technologies, methods and products

### 8.2 Phases of the QFD procedure

QFD procedure usually has three main phases, as presented in the application examples in attached Appendix and in Deliverable D5.1:

1. Selection of the Primary Requirements and their weight factors from a set of numerous detailed Requirements with the aid of QFD matrix
2. Moving the Primary Requirements and weight factors into second QFD matrix for selection between the alternatives of plans, designs, methods or products
3. Sensitivity analysis with simulation of variances of Primary Requirements and Properties [D5.1].

The following detailed procedure can be applied in LIFECON LMS when using QFD for analysis of functional requirements against owner's and user's needs, technical specifications against functional requirements, and design alternatives or products against technical specifications:

1. Identify and list factors for “Requirements” and “Properties”
2. Aggregate and select the Requirements into Primary Requirements

3. Evaluate and list priorities or weighting factors of “Primary Requirements”
4. Evaluate correlation between “Requirements” and “Properties”
5. Calculate the factor: correlation times weight for each “Property”
6. Normalise the factor “correlation times weight” of each “Property” for use as a priority factor or weighting factor of each “Property” at the next steps

### 8.3 Requirements and Properties in Lifecon LMS

#### 8.3.1 Hierarchy of the requirements and properties

Lifecon LMS is aiming to fulfil the requirements of sustainable development, which in the society are defined with very general terms. These generic Requirements are the specified in more detailed factors as presented in Table 1 [D2.1]. For the application of QFD in practice of Lifecon LMS are needed systematisation, which is somehow different from the systematisation in other methods. Therefore this systematisation of Requirements and Properties is presented in more details for QFD.

*Table 1. Generic LIFECON Requirements [D2.1].*

<p>1. Human requirements</p> <ul style="list-style-type: none"> <li>• functionality in use</li> <li>• safety</li> <li>• health</li> <li>• comfort</li> </ul>	<p>2. Economic requirements</p> <ul style="list-style-type: none"> <li>• investment economy</li> <li>• construction economy</li> <li>• lifetime economy in:               <ul style="list-style-type: none"> <li>○ operation</li> <li>○ maintenance</li> <li>○ repair</li> <li>○ rehabilitation</li> <li>○ renewal</li> <li>○ demolition</li> <li>○ recovery and reuse</li> <li>○ recycling of materials</li> <li>○ disposal</li> </ul> </li> </ul>
<p>3. Cultural requirements</p> <ul style="list-style-type: none"> <li>• building traditions</li> <li>• life style</li> <li>• business culture</li> <li>• aesthetics</li> <li>• architectural styles and trends</li> <li>• imago</li> </ul>	<p>4. Ecological requirements</p> <ul style="list-style-type: none"> <li>• raw materials economy</li> <li>• energy economy</li> <li>• environmental burdens economy</li> <li>• waste economy</li> <li>• biodiversity</li> </ul>

In QFD the following categories of compatible Requirements and Properties can be used:

1. Generic Requirements (Table 1)
2. Generic performance Properties (Table 1, Table 2)
3. Generic Performance Properties as Attributes of Lifetime Quality (Table 3 and Table 4)
4. Application-specific Performance Properties as Attributes of Lifetime Quality (D5.1, attached APPENDIX of D2.3 Part II: QFD)
5. Aggregated or primary application-specific Performance Properties as Attributes of Lifetime Quality (Chapter 8.4)
6. Technical Specifications of products (D5.1)

Generic Requirements are always applied as basic requirements independently of the application. These can be described and modelled with the aid of generic performance Properties.

When moving into a specific application of QFD in practice, the generic Performance Properties will be interpreted into generic Attributes, and further into application-specific Attributes of the actual object.

Examples of this procedure have been presented in Lifecon deliverable D5.1, which explain the practical application of the hierarchy of the requirements and properties in details [D5.1].

### 8.3.2 Performance Requirements and Properties

The generic requirements of lifetime quality (Table 1) cannot be used directly in planning and design procedures of Lifecon LMS, because it is not possible to model and describe the solutions of planning, design, methods or products of the asset management and MR&R (Maintenance, Repair, Rehabilitation) planning. Therefore the Requirements and Properties must be defined in each application separately. As a link between Generic Lifetime Quality Requirements and specific calculations, the lists presented below in Table 2, Table 3 and Table 4 can be used [4]. The requirements, which are presented in the column titles of Table 3 and Table 4, must be interpreted for calculations with performance indicators. These performance indicators, which are presented in the cells of Table 3 and Table 4, are variables, which can be expressed in quantitative (numerical) values, and thus can be used in numerical calculations. This is possible, when dealing with so called laboratory problems [Lifecon D 2.1]. When dealing with so called real world problems these indicators have to be expressed qualitatively [Lifecon D2.1]. Table 3 refers to civil infrastructures and Table 4 to buildings.

*Table 2. Specified categories of Generic Requirements [[10], [11], [12], [13]].*

#### **A Performance**

##### A1 Conformity

- A1.1 Core processes
- A1.2 Supporting processes
- A1.3 Corporate image
- A1.4 Accessibility

##### A2 Location

- A2.1 Site characteristics
- A2.2 Transportation
- A2.3 Services
- A2.4 Loadings to immediate surroundings

##### A3 Indoor conditions

- A3.1 Indoor climate
- A3.2 Acoustics
- A3.3 Illumination

##### A4 Service life and deterioration risks

- A4.1 Service life
- A4.2 Deterioration risks

##### A5 Adaptability

- A5.1 Adaptability in design and use

A5.2 Space systems and pathways

A6 Safety

A6.1 Structural safety

A6.2 Fire safety

A6.3 Safety in use

A6.4 Intrusion safety

A6.5 Natural catastrophes

A7 Comfort

## **B Cost and environmental properties**

B1 Life cycle costs

B1.1 Investment costs

B1.2 Service costs

B1.3 Maintenance costs

B1.4 Disposal and value

B2 Land use

B3 Environmental burdens during operation

B3.1 Consumption and loads, building

B3.2 Consumption and loads, users

B4 Embodied environmental impacts

B4.1 Non-renewable natural materials

B4.2 Total energy

B4.3 Greenhouse gases

B4.4 Photochemical oxidants

B4.5 Other production related environmental loads

B4.6 Recycling

## **C Requirements of the process**

C1 Design and construction process

C1.1 Design process

C1.2 Site operations

C2 Operations

C2.1 Usability

C2.2 Maintainability

Table 3. Performance indicators of *civil infrastructures* in LIFECON LMS [D2.1, D2.3 Part I].

	PRIMARY REQUIREMENTS					
	<b>A Lifetime Usability</b>	<b>B Lifetime Economy</b>	<b>C Lifetime Performance</b>	<b>D Lifetime Ecology</b>	<b>E Culture</b>	
<b>Performance indicators</b>	1	Functioning in use	Investment economy	Static and dynamic serviceability in use	Non Energetic resources economy	compatibility with local building traditions
	2	Flexibility in use	Construction cost	Service life	Energetic resources economy	compatibility with local natural and built environment
	3	Health in construction	Operation cost	Hygro-thermal performance	Production of pollutants into air	aesthetic acceptability
	4	Health in use and maintenance	Maintenance cost	Acoustical performance	Production of pollutants into water	acceptability in imago requirements of the built environment
	5	Comfort in use	Repair costs	Operability	Production of pollutants into soil	
	6	Maintainability	Restoration costs	Changeability of structures	Reuse-ability	
	7	Safety in construction	Rehabilitation costs		Recycling-ability	
	8	Safety in use	Renewal costs	Operability	Loss of biodiversity	

Table 4. Performance indicators of *buildings* in LIFECON LMS [D2.1, D2.3 Part I].

	PRIMARY REQUIREMENTS					
	<b>A Lifetime Usability</b>	<b>B Lifetime Economy</b>	<b>C Lifetime Performance</b>	<b>D Lifetime Ecology</b>	<b>E Culture</b>	
<b>Performance indicators</b>	1	Functioning of spaces	Investment economy	Static and dynamic safety and reliability in use	Raw materials economy	building traditions
	2	Functional connections between spaces	Construction cost	Service life	Energetic resources economy	life style
	3	Health and internal air quality	Operation cost	Hygro-thermal performance	Production of pollutants into air	business working culture
	4	Accessibility	Maintenance cost	Safe quality of internal air	Production of pollutants into water	aesthetics
	5	Experienceness	Repair costs	Safe quality of drinking water	Production of pollutants into soil	architectural styles and trends
	6	Flexibility in use	Rehabilitation costs	Acoustical performance	“Reuse-ability” of components and modules	imago
	7	Maintainability	Renewal costs	Changeability of structures and building services	Recycling of wastes in manufacture and repair works	
	8	Refurbishment-ability	Demolition, recovery, recycling and disposal costs	Operability	Loss of biodiversity	

## 8.4 Aggregation of life cycle performance Requirements and Properties

### 8.4.1 Aggregation methods

Because of the complexity of the building system, the decisions between design alternatives of the building, as well as between its technical system, module and product alternatives must be simplified limiting the number of parameters used at the final decisions. For this aim the aggregation of a number of design parameters will be done.

As described earlier, the final objective of LMS system is the optimised life cycle quality which is consisting of four dominant groups of parameters:

1. Lifetime Human Requirements
2. Lifetime Economy
3. Lifetime Cultural aspects
4. Lifetime Ecology

The optimisation and decision making in lifetime management includes often quite numerous variables both on the level of generic requirements and on the level of technical and economic criteria. This can lead to very complex optimisation and decision making procedures. Therefore these parameters of generic and techno-economic levels are aggregated into primary parameters in selection between repair alternatives and products. They are called here "Primary Technical Properties". This can be done applying specific methods, which are presented in Table 5.

*Table 5. Methods used in aggregating the Life Cycle Quality (LCQ) Properties from technical life cycle Properties.*

Life Cycle Quality Property	Aggregation method	Criterion
1. Life Cycle Functionality	Quality Function Deployment (QFD)	Functional efficiency Normative minimum requirements and classifications
2. Life Cycle Monetary Economy LCME	Life Cycle Costing	Economic efficiency (Normative minimum requirements and classifications)
3. Life Cycle Natural Economy (Ecology) LCNE	EPA Science Advisory Board study. Harvard University Study	Ecoefficiency Normative minimum requirements and classifications
4. Life Cycle Human Conditions LCHC	Analysis of Total Volatile Organic Compound (VOC) Emissions. Evaluation of fungi risk. Evaluation of risk of radioactive radiation from materials and from earth. Evaluation of ventilating air quality. Evaluation of health risks of water quality.	Quality classifications of indoor air quality and other indoor air conditions. Quality classifications of acoustic performance. Normative minimum criteria and classifications of safety, health and comfort.
5. Overall Life Cycle Quality	Multi-Attribute Decision Making	Life Cycle Quality (LCQ)

#### 8.4.2 Aggregation procedures

An important phase of the optimisation or decision making procedure is the aggregation of a large number of specific Performance Properties into the LCQ (Life Cycle Quality) Properties. The aggregation procedure includes following stages:

- listing the parameters to be aggregated
- defining the values and weights of these parameters
- summing the values times weights of the parameters into aggregated values.

Examples of these aggregation schemes of LCQ-Parameters are presented in following figures:

- basic HumanConditions Properties in Figure 41.
- functional Properties in Figure 42.
- Life Cycle Costs (LCC) in Figure 43.
- ecological Properties (LCE) in Figure 44.

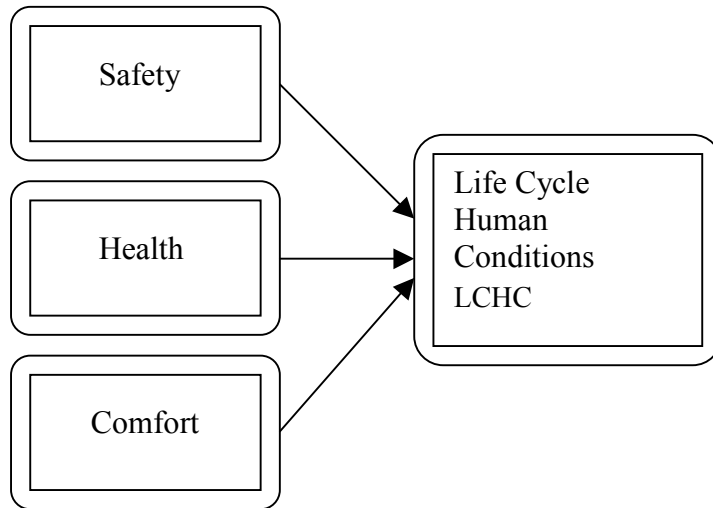

Figure 41. An example of the aggregation of basic Human Conditions Properties.

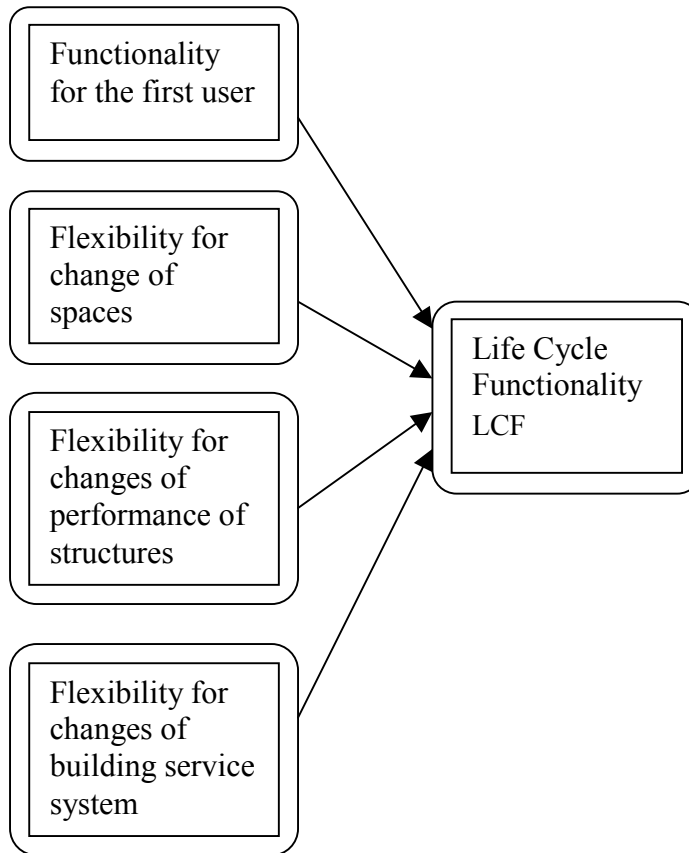

Figure 42. An example of the aggregation of functional Performance Properties.



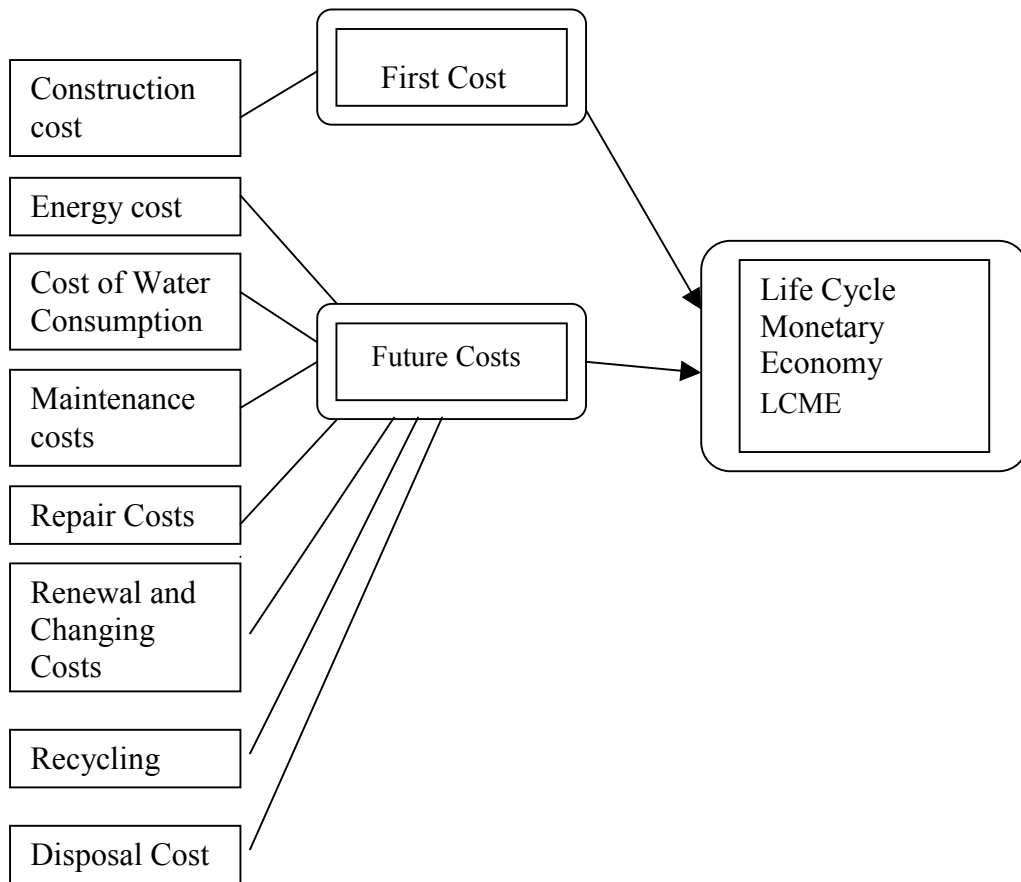

Figure 43. An example of aggregation of Life Cycle Costs (LCC).

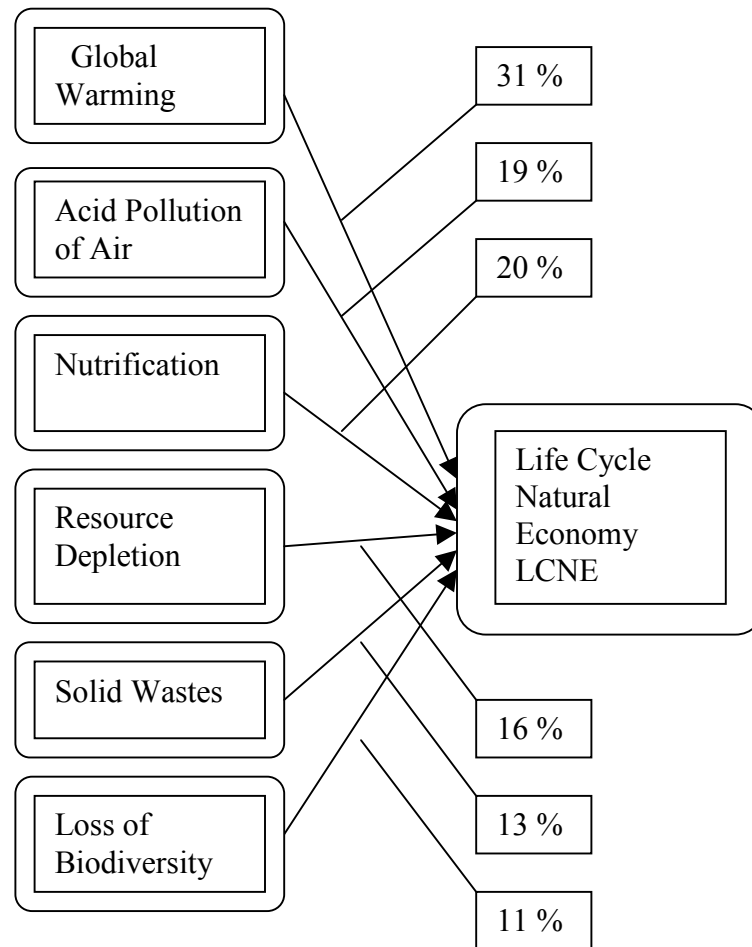

Figure 44. An example of aggregation of ecological Properties, and the weighting coefficients in percentages (LCE) [[7], [8], [14]].

The weighting in aggregation of ecological properties is made on following levels:

1. Global level
2. Regional level
3. Local level

Typical global properties, which always shall have high weight, are the consumption of energy, and the air pollution, which include the factors of global climatic change.

Typical regional properties are e.g. consumption of raw materials and water. On some areas and places these properties are extremely important, but on some other areas they, or some of them, hardly have any meaning.

The aggregation method of ecological properties, which is presented above, can be applied regionally and locally with slightly different weightings. The weights presented above are mainly done from the perspective of USA. Some regional and local applications and simplified methods have been presented. An example of these is the Nordic method [15], which is made for

Northern European conditions. Because most of natural raw materials and water resources are not critical, this method includes only the factors, which are related to consumption of non-renewable energy and pollution of air, soil and water.

The weighting between safety, health and comfort can be made individually. Usually the weights of safety and health are very high, while the weight of comfort can vary in larger range. In any case, safety and health must fulfil the minimum requirements of regulations, which usually are quite strong.

As an example we can take the weights in northern Europe (Scandinavian Countries). There is in a wide use a weighting, where the factors of climatic change and air pollution: CO<sub>2</sub> eqv , SO<sub>2</sub> eqv and ethene<sub>eqv</sub> are taken into account (eqv. means equivalence).

The general aggregated environmental Life Cycle Natural Economy value LCNE, which is described above, can be used in calculating normalised ecoefficiency property ECOEFF. The property ECOEFF can be calculated as a ratio between LCNE of a reference object (product, design solution, building concept, production method etc.) and the LCNE of the actual object, using the equation

$$ECOEFF = LNCE_{ref} / LNCE_{actual} ,$$

where

ECOEFF is the normalised ecological efficiency property

LNCE<sub>ref</sub> Life Cycle Natural Economy parameter LCNE of the reference object

LNCE<sub>actual</sub> Life Cycle Natural Economy parameter LCNE of the actual object

## 8.5 Selection of the Primary Requirements and Properties

The selection of Primary Requirements and Properties of each alternative under selection or optimisation can be based on some of the following methods, which have been described above:

1. Direct strategic decisions of the user organisation between the Generic Lifecon Requirements (choosing between list of Table 1, Table 2, Table 3, Table 4 and Table 5).
2. Analysis of weights of the multiple Requirements and Properties using QFD matrix. The selection is made ranking the Requirements and Properties directly into the order of their weights, which have been gained as a result of this QFD analysis.
3. Handling all or some of the aggregated Requirements and Properties of Figure 41, Figure 42, Figure 43 and Figure 44 as Primary Requirements and Properties.

## **9 IT support for QFD method**

### 9.1 Direct Excel applications

Every user can in principle apply directly Excel program for programming the individual application of QFD matrix calculations with Excel program. This has been done in Deliverable D5.1 and in the examples, which are presented in the attached APPENDIX of this report.

### 9.2 Commercial programs

In continuous use it is more practical to apply some commercial QFD program, which includes a user interface and Excel calculation procedures. As examples of these can be mentioned one of the oldest commercial programs: "QFD/Capture", which is a product of ITI (International Techne Group Incorporated), "QFDwork" of Total Quality Software and "QFD Designer" of Qualosoft firm.

Extensive and updated information on QFD can be found in Internet Website of QFD Institute, USA: <http://www.qfdi.org/>.

## 10 References

- [1] Zairi, M. and Youssef M. A. (1995) “*Quality function deployment: a main pillar for successful total quality management and product development*”. International Journal of Quality & Reliability Management, Volume 12, Number 6 p. 9 – 23.
- [2] Akao, Y., Quality Function Deployment GFD, Integrating Customer Requirements into Product Design. Productivity Press. Cambridge, Massachusetts, USA 1990, 369 pp.
- [3] Quality function deployment, awareness manual. American Supplier Institute, Inc. Dearborn, Michigan 1989. Pp. 106
- [4] Nieminen, Jouni and Huovila, Pekka, Quality Function Deployment (QFD) in design process decision –making. In: Sarja, Asko (Editor), Integrated Life-Cycle Design of Materials and Structures ILCDES 2000. Proceedings of the RILEM/CIB/ISO International Symposium. RILEM Proceedings PRO 14. RIL-Association of Finnish Civil Engineers. Helsinki 2000. Pp. 51-56.
- [5] SARJA, Asko, Integrated Life Cycle Design of Structures. 142 pp. Spon Press, London 2002. ISBN 0-415-25235-0.
- [6] Lakka, Antti, Laurikka, Petri/Vainio, Mikko. Quality Function Deployment, QFD in construction. Technical Research Centre of Finland VTT, Research Notes 1685. Espoo, Finland, 1995. Pp. 54+ App.. (in Finnish)
- [7] Lippiatt, B., Building for Environmental and Economic Sustainability (BEES). Building and Fire Research Laboratory, National Institute of Standards and Technology, Gaithersburg, USA. Manuscript for CIB/RILEM Symposium: “Materials and Technologies for Sustainable Construction”, Royal Institute of Technology, Centre of Built Environment, Gävle, June 1998. 8 p.
- [8] Lippiat, Barbara C., BEES 1.0. Building for Environmental and Economic Sustainability. Technical Manual and User Guide. NISTIR 6144. NIST U. S. Department of Commerce, Technology Administration. National Institute of Standards and Technology. Office of Applied Economics, Building and Fire Research Laboratory, Gaithersburg, Maryland, April 1998. 84 p.
- [9] ISO 6240-1980, Performance standards in building-Contents and presentation
- [10] ISO 6241-1984, Performance standards in building-Principles for their preparation and factors to be considered.
- [11] ISO 6242-Building performance-Expression of functional requirements of users-Thermal comfort, air purity, acoustical comfort, visual comfort and energy saving in heating.
- [12] ISO 7162-1992, Performance standards in building- Contents and format of standards for evaluation of performance.

- [13] ISO 9699-1994, Performance standards in building- Checklist for briefing- Contents of brief for building design.
- [14] Vicki Norberg-Bohm et al, International Comparisons of Environmental Hazards: Development and Evaluation of a Method for Linking Environmental Data with the Strategic Debate Management Priorities for Risk Management, Center for Science & International Affairs, John F. Kennedy School of Government, Harvard University, October 1992.
- [15] Lindfors, L. G. et al, Nordic Guidelines on Life Cycle Assessment, Nord 1995. Nordic Council of Ministers. Århus 1995, 222 pages.

## **APPENDIX: Examples on the QFD procedure**

QFD procedure is strictly guided with the standard formats. Therefore the steps of this procedure are easy to learn. A difficulty is, how the requested correlations are really evaluated in each specific case. This can not be given as a given procedure, but it is a question of expertise.

There are two kinds of problems related to the relations and correlation between requirements and properties: the problems are either so called laboratory problems or real world problems [Lifecon D2.1]. The laboratory problems can be modelled numerically, usually on the base of natural sciences or simulations etc.. The real world problems and variables can not be presented numerically as models, but they must be evaluated with qualitative descriptions first, and then presented subjectively numerically, if possible. Ranking and numerical classifications can be used as a help. This kinds of procedures are presented in following examples.

### 1. DESIGN OBJECTIVES FOR A HOUSING DEVELOPMENT PROJECT [4]

QFD was experimented in an afternoon brainstorming session to set design guidelines for a prototype building to be constructed for Tuusula Housing Fair 2000. The house of quality matrices were formed to judge how well the the original design criteria meet customer requirements and, to judge how well the technical solutions meet the customer requirements.

The exercise was conducted together with ten experts of different backgrounds. The following objectives were set for the working session:

- to share common understanding of the performance-based objectives of the end product (a building to be designed and constructed)
- to prioritise the project objectives
- to strive for innovative design solutions that meet these objectives.

The first matrix (Figure 45) shows the selected main objectives of a housing project (adaptability, indoor conditions, economy, environment friendliness, constructability and architecture) taken as a basis for building design. The second matrix (Figure 46) shows the structured approach in the design process based on the selection made in phase 1.

 <b>PHASE 1</b> Properties		Requirements																			Importance factor
		adaptability	resale value	indoor conditions	attractiveness	economy	autonomy	friendliness to the environment	future	habitability	respond to the environment	good indoor climate	constructability	identity	total ecology	architecture	simple user interfaces	recyclable fair house	transferability	dismountability	
<b>functionality</b>	Utilisability	9	9	9	9	3	9	3	0	9	0	9	0	1	1	0	9	3	1	0	5
	Adaptability	9	3	0	9	3	1	9	3	9	0	0	1	1	9	0	1	9	9	9	2
	Maintainability	3	3	3	3	9	9	9	0	9	0	3	0	0	9	1	3	1	1	1	2
<b>environmental loading</b>	Operation	9	3	9	3	9	9	9	1	1	9	9	0	0	9	0	0	0	0	4	
	Construction	0	0	0	3	3	0	9	0	0	0	0	9	1	9	1	0	9	9	2	
<b>resource use</b>	Energy	9	3	9	3	9	9	9	9	0	9	9	0	3	9	0	0	1	1	5	
	Water	9	1	0	1	3	9	9	3	1	0	0	0	0	3	0	1	0	0	1	
	Materials	3	9	9	3	9	1	9	9	9	0	9	9	9	9	3	0	9	9	1	
<b>life cycle cost</b>	Investment cost	9	9	3	3	9	3	0	0	0	3	3	9	1	0	0	1	3	3	3	
	Operating cost	9	9	1	3	9	9	9	3	0	3	1	0	3	3	9	9	3	3	4	
	Maintenance cost	9	9	3	9	9	9	9	9	0	9	3	0	3	3	9	3	3	3	2	
<b>indoor quality</b>	Acoustic comfort	9	9	9	9	0	0	0	9	9	0	0	3	3	0	9	0	0	0	2	
	Thermal comfort	9	9	9	9	0	0	3	9	9	9	9	3	3	0	9	3	0	0	3	
	Lighting	9	9	9	9	3	9	3	9	9	9	0	3	9	1	9	1	0	0	4	
	Indoor climate	3	9	9	9	0	0	3	9	9	9	9	9	9	1	0	0	0	0	5	
<b>architecture</b>	Architecture	9	9	9	9	9	3	0	9	9	3	0	9	9	0	9	1	3	3	3	
	Weight factor	393	355	322	307	285	273	258	250	248	246	241	182	180	179	169	118	112	102	4317	
	Weight factor %	9%	8%	7%	7%	7%	6%	6%	6%	6%	6%	6%	4%	4%	4%	4%	3%	3%	2%	100%	
	Votes	4	1	3		2	1	3				1	2		4	4	1	1			
	Selected	x		x		x		x					x			x					

Figure 45. Design objectives for a housing project, phase 1.



PHASE 2								
Properties								
Requirements		SPACE	PROCESS	STRUCTURES	MATERIALS	ENERGY	EQUIPMENT	Importance factor (P1)
adaptability, simple interfaces, re-usable fair house		9	9	9	3	3	1	3
indoor conditions, responds to the environment		9	9	9	9	9	9	4
economy, resale value		9	9	9	9	9	9	1
environmental, autonomy, total ecology		9	3	9	9	9	9	5
constructability		1	9	3	1	1	1	3
architecture		9	9	3	9	1	0	2
Weight factor (P1)		138	134	133	120	104	95	724
Weight factor %		19 %	19 %	18 %	17 %	14 %	13 %	100 %

Figure 46. Design objectives for a housing project, phase 2.

2. ENERGY-EFFICIENT DESIGN CONCEPTS FOR OFFICE REFURBISHMENT [4]

The second case study was done in an IEA task 23 Workshop together with Danish, Dutch, Japanese, Norwegian and Finnish experts. The group consisted of practitioners and researchers, architects and engineers. The session was structured and main decisions were documented using QFD (Figure 47). The selected design concepts (daylighting system, new windows, new construction, energy management system, double facades and solar walls) were taken as a basis for building design.

Properties																						
Requirements		daylighting system	new windows	big atrium	new construction	nat ventil & heat rec.	extra insulation	energy mgmt system	demolition	underground space	new lighting system	window renovation	decentr. wat. heating system	double facades	shading	opening facades	roof extension	solar walls PV	new office concept	archive basement	Importance/Weight factor (P1)	
functionality	flexibility	3	0	3	9	1	0	0	1	0	0	0	0	0	0	0	3	0	9	3	3	
	public spaces: access	0	0	3	9	0	0	0	3	3	0	0	0	0	0	0	0	0	0	0	4	
	public spaces: character	3	0	9	3	0	0	0	3	3	3	0	0	0	0	3	0	0	0	0	3	
longevity	comfort	9	9	9	3	3	9	9	3	0	9	9	9	3	3	3	1	0	1	0	5	
	200 years for the bldg	9	3	1	0	3	9	1	0	3	3	3	1	3	3	0	0	0	0	0	3	
	20 years for the first user	9	9	3	0	9	9	9	0	3	3	9	9	3	3	1	0	3	3	0	5	
energy efficiency	- 60 % energy use	3	9	3	0	9	9	9	0	1	3	3	3	9	3	1	0	3	3	0	4	
	daylight	9	0	9	3	0	0	0	9	0	9	0	0	0	0	9	0	0	0	0	4	
	natural ventilation	0	9	3	9	9	0	3	9	0	0	3	0	3	3	3	0	0	0	0	3	
others	architecture?	9	3	9	9	0	0	0	9	9	1	1	0	3	3	3	9	3	3	0	4	
	facades	0	3	0	0	0	0	0	0	1	0	3	0	9	3	0	0	9	1	0	2	
	800 m2 extra for public	0	0	3	9	0	0	0	1	9	0	0	0	0	0	0	9	0	0	9	5	
	environmental friendly	9	9	3	0	9	9	9	0	9	9	3	9	3	9	1	0	9	3	3	4	
Weight factor (P1)		255	243	240	234	198	189	183	170	168	166	151	141	135	123	103	95	93	85	66	0	3038
Weight factor %		8 %	8 %	8 %	8 %	7 %	6 %	6 %	6 %	6 %	5 %	5 %	5 %	4 %	4 %	3 %	3 %	3 %	3 %	2 %	0 %	100 %
Selected		X	X		X			X						X				X				

Figure 47. Design concepts for office refurbishment.

### 3. DESIGN PRIORITIES IN AN ENVIRONMENTAL FRIENDLY NURSERY SCHOOL [4]

The third QFD example was to set the project objectives with a view to the building user's needs and requirements and, to show how the chosen criteria and the view, the user's view affect the results. QFD matrix was used to capture, record and verify the client's requirements and, to test the dependency between the requirements and the properties of the introduced building concept.

The project used in the test is a nursery school for about 100 children to be built in the year 2000. The design process of the building is to be finished towards the end of 1999, based on an architectural competition. The nursery school Merituuli will be built in a new suburban housing area, a former industrial area, where the basic infrastructure has already been developed (streets, access to main roads, district heating net, etc.). The location of the area is very close to the city of Helsinki with a good public access to the city, a fact that has made the area very popular especially among young families. This has also grown to be a design feature for the nursery school building and its connection to the surrounding housing area.

The building will serve as a nursery school daytime, and in the evening as a meeting point for local inhabitant activities. The total building area is 1260 m<sup>2</sup> one storey. The owner of the building is the City of Helsinki, and the building is constructed by the Construction Management Division of the City of Helsinki (HKR).

In a number development sessions, arranged both between HKR and VTT in the beginning of the project and, later on between the designers, project management and VTT, the project goals and limits were discussed and the requirements were set. The design briefing tool ECOProP was used as guidelines for the sessions and to document the results and decisions reached during the sessions.

The decision making in the project was tested against the main criteria adopted from the IEA Task 23 frame work. The results of the design briefing sessions were used as building owner defined sub-requirements in compiling the QFD matrix (Figure 48).

VTT	PHASE 1 Properties																		Importance/Weight factor (P1)			
	Requirements	district heat	bicycle access to site	cleanable ducts	multi-use playrooms	low energy envelope	mechanical ventilation + HR	changeable duct components	separated service space	super windows	floor heating	solar control	yard facing South	stimulating spaces, child scale	L-form	separated public evening use	ordinary windows	traditional envelope		radiators		
LCC	low investment cost	9	1	0	9	0	0	0	0	0	0	0	0	0	3	0	0	0	0	5		
	low service cost	9	1	9	3	9	0	0	3	9	3	3	0	0	3	0	0	0	0	4		
	low maintenance cost	9	1	9	3	0	0	9	9	0	1	0	0	0	1	0	0	0	3	1		
resource use	low electricity consumption	9	0	3	3	1	0	0	0	0	0	3	9	0	0	0	1	0	0	4		
	low water consumption	0	0	0	0	0	0	0	0	0	0	0	0	0	0	0	0	0	0	4		
	long service life	0	0	3	0	0	0	9	3	0	0	3	0	0	0	0	0	0	1	3		
environmental loading	low CO2, NOx, SO2 emissions	9	0	0	0	9	9	0	0	9	0	9	0	0	0	0	0	0	0	5		
	particles	0	0	9	0	3	9	9	0	0	0	0	0	0	0	0	0	0	0	5		
	existing infrastructure	9	3	0	0	0	0	0	0	0	0	0	0	0	0	3	0	0	0	1		
archit. quality	home-like	0	9	0	9	0	0	0	1	0	3	0	3	3	1	0	0	0	1	3		
	attractive to children	0	3	0	9	0	0	0	0	0	9	0	3	9	1	0	0	0	0	4		
	public service building	3	9	3	0	1	3	3	1	1	0	0	0	0	1	9	0	0	0	1		
indoor quality	air purity + emissions	0	9	9	0	0	3	3	0	0	0	0	0	0	0	0	0	0	0	5		
	high thermal quality	0	0	0	0	9	9	0	0	9	9	9	0	0	0	0	0	0	1	3		
	illumination	0	0	0	0	0	0	0	0	0	0	0	3	0	3	0	3	0	0	5		
	echoing	0	0	0	0	0	0	0	0	0	0	0	0	0	0	0	0	0	0	1		
	low HVAC noise	0	0	1	0	3	0	0	9	0	1	0	0	0	0	0	0	0	0	2		
functionality	user access to site	0	9	0	0	0	0	0	0	0	0	0	0	0	3	0	0	0	0	4		
	service access	0	0	0	0	0	0	0	9	0	0	0	0	0	3	0	0	0	0	3		
	safety in use	3	3	0	0	0	0	3	9	0	3	0	3	9	3	0	0	0	0	5		
	evening use	0	9	0	0	0	0	0	0	0	0	0	3	0	0	9	0	0	0	1		
	high adaptability	0	0	1	9	1	0	9	3	1	3	1	0	0	1	9	0	0	0	2		
Weight factor (P1)		207	169	163	153	136	135	132	130	111	108	107	90	90	89	42	24	15	12	0	0	1913
Weight factor %		11%	9%	9%	8%	7%	7%	7%	7%	6%	6%	6%	5%	5%	5%	2%	1%	1%	1%	0%	0%	100%
Selected		X	X	X	X	X	X	X	X	X	X	X	X	X	X	X	X	X	X	X	X	X

Figure 48. Design priorities for a nursery school.

Using the ECOProP requirements listing, properties for a nursery school building were discussed and selected keeping in mind the most important requirements for the building:

- low investment and service costs
- low environmental impacts in use
- good indoor climate
- existing infrastructure
- safety in use
- attractive to children.

A set of building concepts was developed for evaluation purposes. The energy performance and environmental impacts of the concepts, ranging from an typical nursery school building in Helsinki to a low-energy building utilising solar energy, were analysed using the results of energy analysis as a starting point. The environmental impacts were compared with the requirements set in the pre-design phase.

This evaluations shows, that the environmental targets of the project can be fulfilled with a typical building type used in construction of nurseries and nursery schools. However, there is conflict between the environmental goals and life cycle costs, in terms of low service and

investment costs. The extra building costs of a low-energy building are in the order of magnitude 50 - 100 Euro/m<sup>2</sup>.

Technical properties of the building alternatives, corresponding to the above mentioned criteria were documented as properties in the QFD matrix (Figure 48). The dependencies between the given requirements and properties were checked. According to the QFD results, the main properties of the nursery school building corresponding to the given requirements are

- district heat
- bicycle access to the site
- cleansable ventilation ductwork
- multi-use playrooms for children
- low-energy building envelope.

According to the QFD results, the requirements dealing with functionality or air quality in a nursery school are dominating the pre-design process. The present energy (district heat) price is so low, that the extra costs of energy saving are difficult to argue.

## **PART III:**

# **Risk Assessment and Control**

**Author: Tommi Rissanen**

## Keywords

Lifecon, risk, risk analysis, fault tree, event tree, decision making

## Abstract

This part of the deliverable D2.3 focuses on risk management issues in concrete facility management. The central terms of risk discipline are first briefly described, as well as the most utilised risk analysis methods. Preconceptions about 'risk' are corrected and with the help of few examples the meaning of risk management discipline and risk-based decision making is presented in understandable format.

The major part of this report concentrates on presenting a generic risk management procedure that respects the Lifecon principle of being predictive and integrated. Risks are analysed for the whole lifetime of the infrastructure and categorised to the four classes according to generic Lifecon division: human, cultural, economic and ecological. The roles of different stakeholders are clarified: facility owners, end users, contractors, society, authorities and risk analysts all have tasks and responsibilities in the generic Lifecon risk proposal.

The generic Lifecon risk proposal is not bound to any specific software. However, some risk analysis methods are preferred in Lifecon risk proposal. These are fault and event tree analysis. The perspicuity and flexibility of those two methods are big advantages in establishing a new way of handling risks. The analyses can be performed qualitatively or quantitatively and they can be easily updated for the future challenges. In case of quantification the use of simulation is recommended.

The generic Lifecon risk proposal procedure can be described with the following four steps:

1. Identification of adverse incidents
2. Analysis of the identified adverse incidents
  - deductively, in order to find causes
  - inductively, in order to find consequences
3. Quantitative risk analysis
4. Risk-based decision making (and continuous updating of risk database)

The examples of the report make the Lifecon risk proposal very understandable for the reader. However, to fully apply the presented approach in practice is not an easy task, because it requires changes to the current way of thinking and working. The most important requirements on *mental* level are:

- Commitment - Risk management should be an integral part of concrete facility management. That needs resources and strategic decisions from management.
- Multi-disciplinary, efficient co-operation and openness - As there are many stakeholders involved in concrete facility management, the co-operation between different parties should be very smooth in order to have efficient progress and development.
- Patience - Changes take time, despite the aspirations of prevailing quarter economy philosophy. Especially the required changes in human behaviour, attitude and way of thinking need time.

## List of Contents

### Author of Part III: Tommi Rissanen

PART III:.....	93
Risk Assessment and Control.....	93
Abstract .....	94
List of Contents .....	95
List of terms, definitions and symbols .....	96
11 Introduction .....	98
11.1 Aim of Lifecon risk assessment and control .....	98
11.2 Role of risk in construction sector .....	98
11.3 Quantification problem .....	99
12 Risk analysis methods .....	102
12.1 Common factors to all risk analysis methods .....	102
12.2 Preliminary hazard analysis (PHA).....	103
12.3 Hazard and operability study (HAZOP) .....	103
12.4 Failure mode and effect analysis (FMEA).....	104
12.5 Event tree analysis (ETA) .....	105
12.6 Fault tree analysis (FTA) .....	109
13 Lifecon risk assessment and control procedure.....	116
13.1 Introduction.....	116
13.2 The steps of the procedure .....	117
13.2.1 Identification of adverse incidents.....	117
13.2.2 Analysis of the identified adverse incidents .....	118
13.2.3 Quantitative risk analysis.....	121
13.2.4 Risk-based decision making .....	122
13.3 Using Lifecon risk assessment and control procedure in practice .....	123
13.4 Qualitative or quantitative risk analysis; Discussion .....	125
14 References.....	126
Appendices .....	127
A. Illustrative example of Lifecon risk quantification procedure.....	127

## List of terms, definitions and symbols

<b><i>Adverse incident</i></b>	Unwanted event, mishap, accident, failure, unintended hazardous outcome, that causes detrimental consequences.
<b><i>ALARP</i></b>	ALARP (As Low As Reasonably Practicable) refers to a level of risk that is neither negligibly low nor intolerably high, for which further investment of resources for risk reduction is not justifiable.
<b><i>Common cause failure</i></b>	An event or mechanism that can cause two or more failures simultaneously is called a common cause. The failures are referred to as common cause failures.
<b><i>Cut set</i></b>	Any group of fault tree initiators which, if all occur, will cause the top event to occur.
<b><i>Decision-maker, end user, facility owner</i></b>	Used in alternative sense in this deliverable D2.4, refers to the "owner" in Generic Handbook Terminology: Person or organisation for whom/which structure is constructed and/or the person or organisation that has the responsibility for maintenance and upkeep of structural, mechanical and electrical systems of the building.
<b><i>Event tree analysis (ETA)</i></b>	A logical network that begins with an initiating event and progresses through a series of branches that represent expected system performance and arrives to final events and consequences.
<b><i>Failure mode and effect analysis (FMEA)</i></b>	A process for hazard identification where all conceivable failure modes of components or features of a system are considered in turn and undesired outcomes noted.
<b><i>Failure mode, effect and criticality analysis (FMECA)</i></b>	An FMEA where additionally the criticality of a failure mode or failure cause is assessed by estimating the severity and probability of the failure. Severity and probability are each expressed as ranking indices.
<b><i>Fault tree analysis (FTA)</i></b>	A logic diagram showing the causal relationships between events, which singly or in combination result in the occurrence of a higher-level event. It is used to determine the frequency of a "top event" which may be a type of accident or an unintended hazardous outcome.
<b><i>Hazard and operability study (HAZOP)</i></b>	A study performed by application of guidewords to identify the deviations from the intended functions of a system which have undesirable causes and effects for safety and operability.
<b><i>Hazard identification</i></b>	A hazard is a source of potential harm or a situation with a potential to cause adverse effect. Hazard identification looks at the source of the risk, or the characteristics of the site that might lead to risk.
<b><i>Initiating event</i></b>	The first of a sequence of events leading to a hazardous situation or accident.



<b><i>Minimal cut set</i></b>	A least group of fault tree initiators which, if all occur, will cause the top event to occur.
<b><i>Monitoring</i></b>	To check, supervise, observe critically, or record the progress of an activity, action or system on a regular basis in order to identify change.
<b><i>Risk</i></b>	A measure of the likelihood that an undesirable event will occur together with a measure of the resulting consequence within a specified time, i.e. the combination of the frequency and the severity of the consequence. (Can be either a quantitative or qualitative measure.)
<b><i>Risk acceptance</i></b>	Informed decision to accept the likelihood and the consequences of a particular risk.
<b><i>Risk analysis</i></b>	A systematic use of available information to determine how often specified events may occur and the magnitude of their likely consequences.
<b><i>Risk assessment</i></b>	The process used to determine risk management priorities by evaluating and comparing the level of risk against pre-determined standards, target risk levels or other criteria.
<b><i>Risk-based decision-making</i></b>	A process that organises information about the possibility for one or more unwanted outcomes to occur into a broad, orderly structure that helps decision-makers make more informed management choices.
<b><i>Risk control</i></b>	The part of risk management that involves the provisions of policies, standards and procedures to eliminate, avoid or minimise risks.
<b><i>Risk estimation</i></b>	The scientific determination of the characteristics of risks, usually in as quantitative a way as possible. These characteristics include the magnitude, spatial scale, duration and intensity of adverse consequences and their associated probabilities as well as a description of the cause and effect links.
<b><i>Risk evaluation</i></b>	A component of risk assessment in which judgements are made about the significance and acceptability of risk.
<b><i>Risk management</i></b>	Discipline or systematic process which ensures that an organisation does not assume an unacceptable level of risk.
<b><i>Top event</i></b>	The event at the very top of the fault tree, referred to as adverse incident, for which the fault tree analysis determines the causes and frequency.

## 11 Introduction

### 11.1 Aim of Lifecon risk assessment and control

The aim of this deliverable is to cope with lifetime risks of concrete facility management keeping in mind the four principal viewpoints of Lifecon, i.e human conditions, culture, economy and ecology. The main objectives of Lifecon risk assessment and control are:

- to make facility owner aware of the risks *in Lifecon extent* (meaning the four viewpoints)
- to form a solid framework and base for risk-based decision making
- to give guidelines how to use the Lifecon risk approach in decision-making process

In this first chapter some background information is given to get the readers on the same starting line. In the second chapter the most utilised risk analysis methods are briefly presented, and finally in chapter 13 the Lifecon risk assessment and control proposal is introduced.

### 11.2 Role of risk in construction sector

Risk is a subject that has normally been interlinked with highly complex and complicated systems, like operation of power plants, processing industry, pipelines, oil rigs, space industry and so on. Risk analysis techniques have also for long been a part of project management when economical issues have been treated.

In construction industry risks have traditionally been treated just in structural safety context. Of course that is the main concern and target of the designer: how to design and maintain a structure in such a way that it satisfies the structural safety limits set by the authorities but at the same time would not be too conservatively designed and maintained?

Differing from processing industry, in construction sector the facilities can be in quite poor condition and still "satisfy" the basic need. In processing industry for example cracks in the pipelines can not be accepted, because they would be fatal for the system. In concrete facilities cracks are unwanted but unfortunately rather common phenomena, but unlike in processing industry, the cracks do not cause immediate fatal threat to the safety of the system.

Fortunately, the present societal trends in construction industry promote sustainable development and customer orientation and satisfaction, which all work in favour of better-maintained concrete facilities. Little by little limit states are becoming more and stricter. With increasing national and global wealth more emphasis is placed also on environmental, human and cultural issues and not just on minimising construction and maintenance costs. At the same time with the development of the computational potency of modern computers, better and more accurate decision making and risk analysis methods have been and are being developed. This fact is known also by authorities, stakeholders and funding partners, and consequently the decisions as well as the explanations for allocation of expenses must be better optimised and argued. As an answer to these new challenges, risk analysis techniques have been proposed. They are flexible and can be applied to help in decision making in very wide range. However, the construction industry in general is very traditional discipline with old role models, and implementing new ideas and methods take time, but sooner or later risk analysis methods will be routine also in construction sector.

Dealing with risks should not be a separate item to be introduced just in case of emergency. Instead, it should be a part of the management like any management: cost management, time management, etc. and it should have a logical structure. A possible structure for risk management is shown in figure 49.

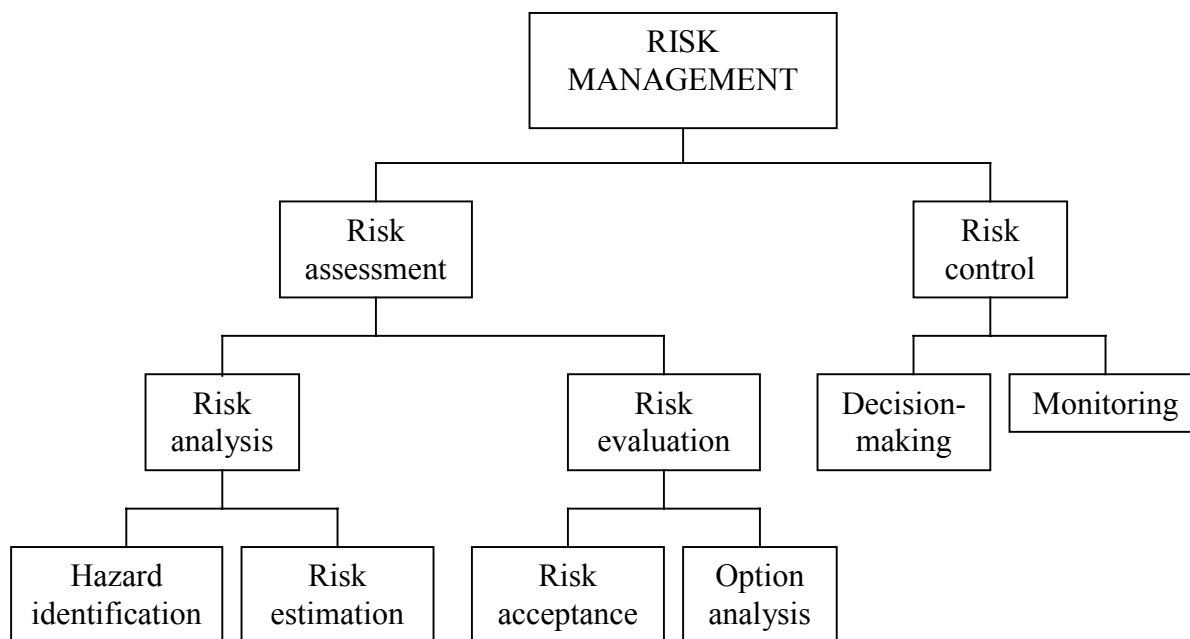

Figure 49. Structure of risk management [1].

As can be seen in figure 49, risk analysis is an essential part of the risk management, but on the other hand, just doing a risk analysis is not enough, it must not be excluded from the bigger context. Traditionally 'risks' have been treated in two different ways. The other is **diagnostic risk analysis** and the other **risk-based decision making**. The former is basics, concentrating on identification of the main contributors of risks, while the latter goes much further, trying to use the information of diagnostic risk analysis and then quantify the risks. Theories and methods for quantification exist, but the implementation into practise is still low in construction sector.

### 11.3 Quantification problem

Qualitative approach in risk analysis is quite simple. More than anything it is logical thinking, structuring down the problem into smaller pieces, which can then be dealt with, one by one. An experienced engineer can produce rough estimations for failure frequencies and consequences, and a brainstorm session of many experts can make the estimations even better. If relative measures are used the quality of results normally maintains a good level. But if exact numbers are wanted, the situation is not the same. In some discussions it has been estimated, that even the best risk calculations should be regarded as accurate to only within 1 or 2 orders of magnitude, when it comes to small probabilities [2].

Problems are caused also by the lack of established limits. In structural safety matters some limits are gaining consensus, namely  $10^{-3}$  for the service limit state and  $10^{-6}$  for the ultimate limit state, when new structures are concerned. However, the situation is different when old structures are concerned, and the consensus about the probabilities of failure is no more complete.

Numbers between  $10^{-2}$  and  $6 \cdot 10^{-4}$  have been suggested but even then the discussion has been considering only the ultimate limit state [3]. In Lifecon context this structural safety issue is only one part of the human viewpoint, and there are three more whole viewpoints (i.e. economical, ecological and cultural) without any established number-based limits. Of course there are some legislation about these issues also, but the regulations and restrictions are of qualitative form.

With fatal accidents a principle of ALARP (As Low As Reasonably Practicable) is gaining popularity. The idea of ALARP is that if the probability of death is low enough (the frequency of death for an individual is for example  $10^{-6}$ /year), the situation is acceptable. But if the frequency is greater than say  $10^{-3}$ /year, the situation is unacceptable and improvements for the safety must be made immediately. In between these two limits the ALARP principle is applied: the probability of death is reduced to As Low As Reasonably Practicable, meaning that if the costs of reducing the probability of death exceed the benefits or improvements gained, then the original risk is accepted. The question is once again of qualitative form, "reasonably practicable". And what are the ALARP-limits for cultural, ecological and economical risks?

One problem in quantification is the use of deterministic values instead of statistical distributions. It is true that stakeholders (practical engineers, decision-makers, facility owners etc.) are more familiar with exact numbers than distributions, but if a numerical estimation for risk is required, then using distributions in calculations gives better results. By using a characteristic value and a safety factor it is possible to check if some condition for the risk is fulfilled, but the actual value of risk is not obtained. The variation and uncertainty of variables are best described with either standard mathematical or experimental distributions. The simulation methods will eliminate the problem of the difficult analytical integration. Most commercial QRA (Quantified Risk Analysis) softwares use simulation techniques. By using distributions in calculations the results of analyses will also be distributions which tell a lot more than a single value.

Unfortunately, to find out the source distributions for different variables is not an easy task. In processing industry (where the risk analysis methods were developed) the situation is easier. Although the whole process may seem highly complex, it can be split into discrete phases, where the successful operation of that phase is a function of just few variables. The high degree of automation has reduced the possibility of a human error, the operation conditions are always the same, access to the area is restricted etc. All this has enabled consistent gathering of relevant information from the functioning of the process. With concrete civil infrastructures the situation is different. The facilities stand in various open environments, access is quite easy for everybody, construction and maintenance require a lot of manpower, etc. The multi-dependent nature of construction or maintenance project is not easy to handle or model. A characteristic feature in construction industry compared to processing industry is the lack of consistent source data and information, which causes problems in quantification the uncertainty and risks.

One more problem in quantitative analysis is caused by the mathematical definition of risk. Risk, being a product of two uncertain factors (i.e. probability of occurrence of a scenario and consequences of that scenario) can mislead the decision-maker, if it is introduced as one number only. This is illustrated in the figure 50. The two cases have the same yearly risk (the numbers are more or less arbitrarily chosen for illustration purpose only), but for the facility owner the second case is disastrous, while the first one can be handled. The case number two is not as

probable as the first one, but the consequences are huge and will bankrupt the owner if the scenario comes true. But still the **risk** is the same in both cases, namely 150 €/year.

Case (= adverse scenario)	Probability of occurrence	Consequences	Risk
Power failure silences the skyscraper for two hours	0,0001/year	1 500 000 €	<b>150 €/year</b>
Aeroplane crashes the skyscraper	0,00000001/year	15 000 000 000 €	<b>150 €/year</b>

*Figure 50. Illustration of the shortcoming of defining risk with only one number.*

The example in figure 50 is quite macabre, but it clarifies the problem when using only one number for risk. On the other hand, this very example highlights one more unsolved problem of risk analysis, namely "the low probability - high consequences" -problem. These scenarios can not be included in normal risk analysis models, but somehow they should be taken into account in decision making.

## 12 Risk analysis methods

The risk analysis methods were developed within the processing industry, where the systems and procedures are quite automatic and the role of human activity is not decisive. However, the principles of the methods are quite applicable also in other sectors of industry. For example, many routines in concrete facility management can be thought as discrete processes with logical structure, so in evaluating uncertainties the general risk analysis methods can be applied.

### 12.1 Common factors to all risk analysis methods

The risk analysis methods as such are simple logical chains of thinking, there is no higher mathematics included in the principle. As mentioned before, the methods were first used in processing industry, and because that sector had the early head start there exist many detailed and case-tailored risk analysis methods in processing industry, while in construction sector more general methods are used. But the three basic questions to be answered remain the same, regardless of the method:

- What can go wrong?
- How likely is it?
- What are the consequences?

The choice of analysis method depends on many variables like source data, resources, expertise, risk category, phase of the project, and especially the nature of the problem. In every method the basic structure of "dealing with risks and uncertainty" is a logical, phased process that is roughly divided in five steps. These steps are:

1. Identification of the possible adverse incidents (hazards, mishaps, accidents)
2. Identification of the causes and consequences of the adverse incidents, and building of structured causal relationships between them
3. Estimation of the likelihood of causes and consequences, as well as the severity of the consequences
4. Evaluation and quantification of the risks
5. Decisions and actions to deal with the risks

The first two steps are an essential part of any risk analysis (being a part of qualitative diagnostic risk analysis), while the next two are necessary only if some quantitative values are needed. The last step is again an obviousness.

Apart from the logic of risk analysis procedure, another fact binds the different risk analysis methods: strong expertise is needed and the results depend highly on how rigorously the analyses are performed. No shortcuts should be taken if real benefits are wanted. It should be remembered that a huge part of the accidents, failures and unintended events happen due to negligence, not ignorance. All risk analysis methods (when pertinently carried out) include brainstorming and prioritisation processes performed by a **multi-discipline** team consisting of members from different stakeholder groups. These people who give "raw material" (data, opinions, estimations etc.) for risk analyses, must be experts with solid experience in their business. These are for example maintenance engineers, facility owners, statisticians, inspectors, material suppliers, etc.

The person who conducts a risk analysis, on the other hand, does not have to be an expert in facility management, repair methods or materials etc. Instead, he must have other skills, for example such as:

- experience in the risk management process
- routine and experience with risk management tools
- neutrality in the project (e.g. no partnership with contractors)
- analytical way of thinking
- superior facilitation skills
- excellent communication skills

The most utilised risk analysis methods are briefly presented in the following chapters, with some guidelines about their normal use and applications, and notes about their benefits and shortcomings.

## **12.2 Preliminary hazard analysis (PHA)**

This method is an initial effort to identify potential problem areas. It is a basic qualitative study considering larger operational components, not detailed interactions. The main benefit of PHA is the awareness of the hazards it creates. Depending on the depth of the analysis, the time to complete PHA is normally relatively short. PHA is not the most systematic or established method, and for example in the literature the results of PHA vary from presentiments of possible hazards to the evaluation of the risks, but it gives a good starting point to the further analysis. The normal output of PHA is a list of possible hazards, classified for example by the phases of the process or system, or by the targets (personnel, product, environment, structure, reputation etc.). A very thorough PHA output could include following information:

- hazard description (source - mechanism - outcome)
- mission/system/project/process phases covered
- targets (meaning the potential hazard "victims")
- probability interval
- subjective assessment of severity of consequences (for each target)
- subjective assessment of probability of occurrence (for each target)
- assessment of risk (product of the previous two)
- countermeasures, safeguards, actions

In some contexts the PHA and HAZOP (presented in the chapter 12.3) have been used in alternative sense, but of those two HAZOP is a real risk analysis method while PHA has a little bit more unofficial reputation.

## **12.3 Hazard and operability study (HAZOP)**

HAZOP method is mainly used in processing industry to find out hazards, but in the wide context some routine phases of construction can be thought as processes, and in the very preliminary stage this method can be used. The idea of HAZOP is to study what kind of consequences can occur in case of little deviations from the intended use or operation of the process.

In the HAZOP method the process is first described completely and then it is divided in phases (called nodes) and the deviations are addressed at those nodes. The brainstorming team will

consider one node at a time and the results will be recorded for each node in columnar form, under the following headings:

- deviation
- cause
- consequence
- safeguards (the existing protective methods/devices to prevent the cause, or safeguard against adverse consequence)
- action (to be taken in case of too serious consequences, for example applying the rule of the three R's: Remove the hazard, Reduce the hazard, Remedy the hazard)

HAZOP method consumes a lot of time and resources, but it is very easy to learn. The long practical experience in the operational sector is of great help and use.

#### **12.4 Failure mode and effect analysis (FMEA)**

FMEA describes potential failure modes in a system and identifies the possible effects on the performance of the system. In the five-step-process (described in chapter 12.1) FMEA mostly deals with the steps one and two, although some semi-quantitative estimations can be given. The product of an FMEA is a table of information that summarises the analysis of all possible failure modes. Traditionally FMEA has been used for concrete processes or structures where the system can be divided into smaller parts, modules, components etc. but theoretically it can be used in more abstract projects also.

First the system must be described in such a way that the operation, interrelationship and interdependency of the functional entities of the system become clear to all parties involved. Then the FMEA starts by identifying the possible failure modes - meaning the manners in which a component or system failure occurs - for all the components. Theoretically there are innumerable failure modes for each component (and no limit to the depth one can go), but practically there is a point, after which the additional costs exceed the benefits.

After finding out the failure modes, the failure mechanisms must be identified. In this phase the question to be answered is: "How could the component or system fail in this failure mode?" A very simple illustration of this is obtained from the durability of concrete: the erosion. The failure mode is the erosion and the failure mechanism is the flowing water acting on concrete. One failure mode can of course have more than just one failure mechanism. The failure modes of the components are normally known, but the failure mechanisms (the causes) are sometimes more difficult to identify.

The FMEA continues with the identification of the failure effects. The consequences of each failure mode must be carefully examined. In the erosion example above the obvious effect is a surface deterioration but it can have worse effects too, like reduced bearing capacity and finally a collapse. The effects of the component failure should be studied on all the abstraction levels of the system (from the component level to the system level).

Once the failure modes are identified, the failure detection features for each failure mode should be described. Also, at each abstraction level (component, module, system) provisions that alleviate the effect of failure should be identified.



The analysis above is carried out in a qualitative way, but it is possible to add some semi-quantitative features in FMEA. When some estimations of the likelihood of occurrence of the failure modes and severity of the failure effects are given, the FMEA method is called FMECA. The letter C stands for Criticality, which is the combination of the likelihood and severity. The criticality indicates the importance of that particular failure in risk analysis.

The results of FMEA are presented in table form. The practical minimum for the number of columns is four, i.e. the element (component), the failure mode, the failure mechanism and the failure effect. However, normally the columns are tailored for the case in question, and can have for example following labels on the top row:

- event identification
- name of the element
- concise description of the function of the element
- modes of failure of the element
- causes of failure and operational conditions under which it can occur
- consequences of the failure on the system (locally and globally)
- means of detecting a failure of the element
- means of preventing the appearance of failure (redundancies, alarms, ...)
- classification of severity
- comments and remarks
- probability of occurrence (estimate) in FMECA
- criticality (calculation) in FMECA

Like any other risk analysis method, the FMEA also should be introduced into the project from the very beginning. Being more qualitative than quantitative method, the FMEA is never pointless. It reduces uncertainty in decision making even if exact numbers are not required. Depending on the need, the FMEA can be tailored from very rough to very detailed. For years, FMEA has been an integral part of engineering design and has grown to be one of the most powerful and practical process control and reliability tools in manufacturing environments. Especially, FMEA is a tool for identifying reliability, safety, compliance, and product non-conformities **in the design stage** rather than during the production process. A shortcoming in FMEA is that it is performed for only one failure at a time. So it may not be adequate for systems in which multiple failure modes can occur at the same time. Deductive methods (for example FTA, presented in chapter 12.6) are better in identifying these kinds of failures. FMEA does not include human action interface, system interaction nor common cause failures. FMEA generally provides basic information for FTA.

### 12.5 Event tree analysis (ETA)

If the successful operation of a system (or project, process, etc.) consists of chronological but discrete operation of its units, components or sub-systems, then ETA is a very useful method to analyse the possible risks of the case. ETA is an inductive method, it starts with a real or hypothetical event (called **initial event**) and proceeds with forward analysis to identify all the possible consequences and final outcomes of that initial event. The driving question in ETA is: "What happens, if...?"

No specific symbols are used in ETA (like is done with FTA, see chapter 12.6), but just simple logic. Normally event trees are developed in binary format, meaning that the possible events either occur or do not occur. This is quite logical for example in case of some accident in processing industry, where some initial event should wake the safeguard operation. This operation then occurs or does not occur (success or failure), and then comes the next event and so on, until the final event is reached.

However, in general case the initial or subsequent event can of course have more than just two outcomes. In such a situation the events stemming from the node (the inception of the subsequent event) are chosen such as being mutually exclusive. This means that no simultaneous occurrence of two or more subsequent events is possible and as a consequence, the sum of the probabilities at a node is always equal to one. The general case is presented in figure 51.

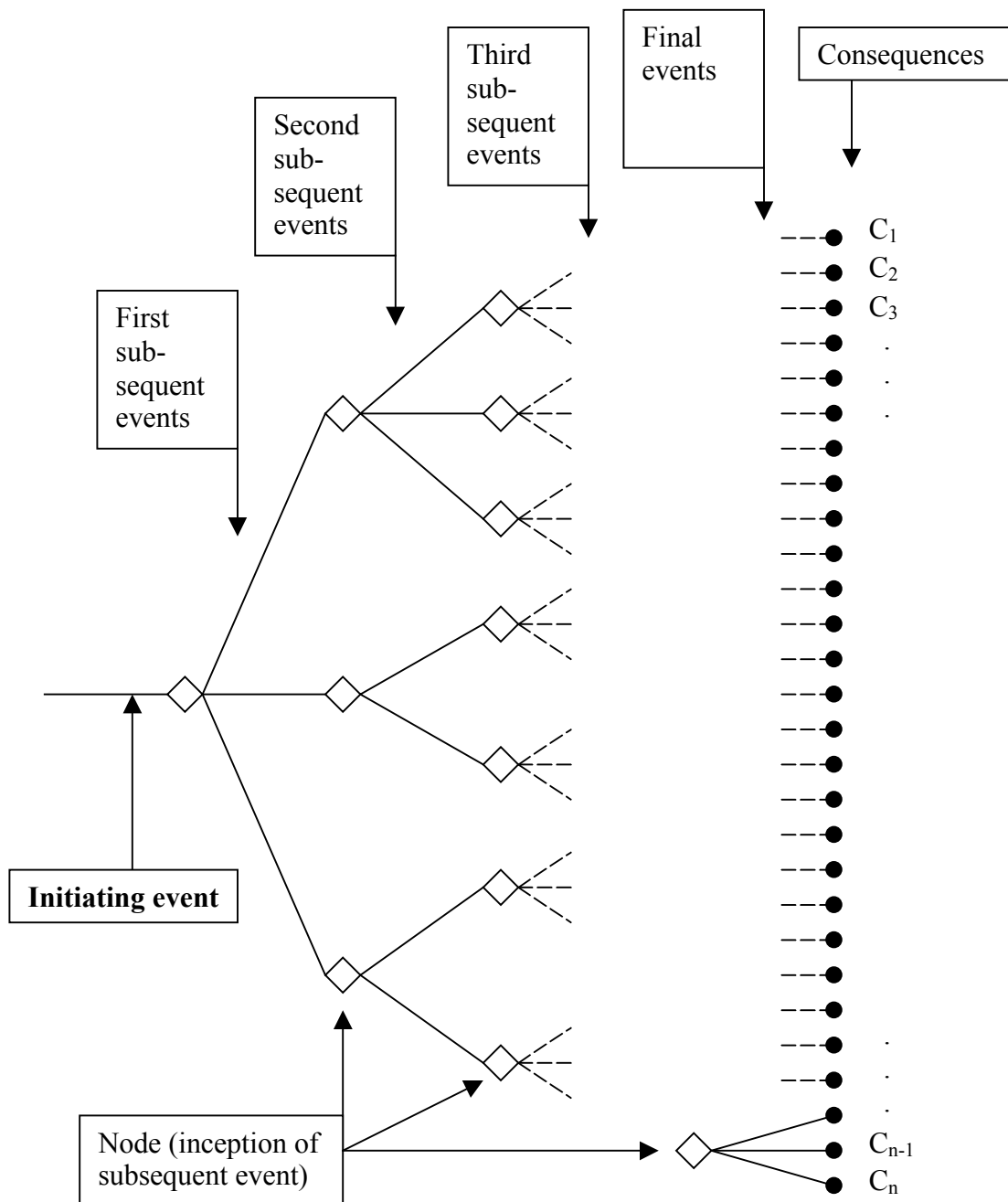

Figure 51. The event tree (general case).

The more common binary format use of ETA is illustrated in figures 52 and 53. Like in the general case, the construction of the event tree starts from the left. The preceding events (normally the safety systems and operations) are listed in chronological order on the upper edge of the figure. On the right are mentioned the final outcomes, consequences and calculated frequencies.

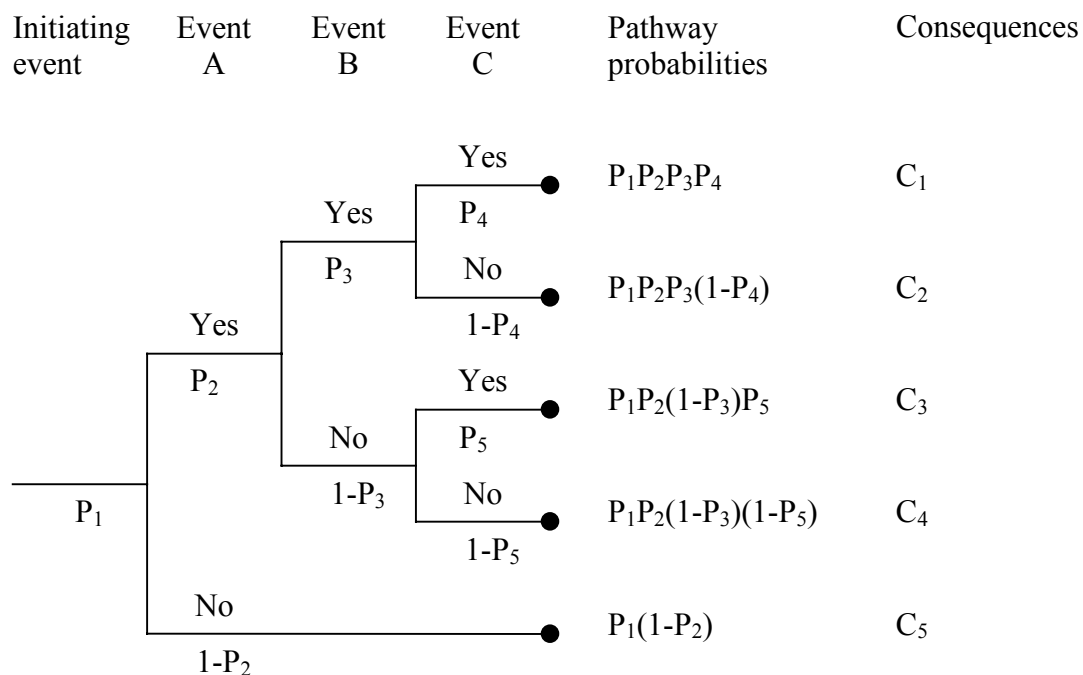

Figure 52. The event tree (binary case, general illustration).

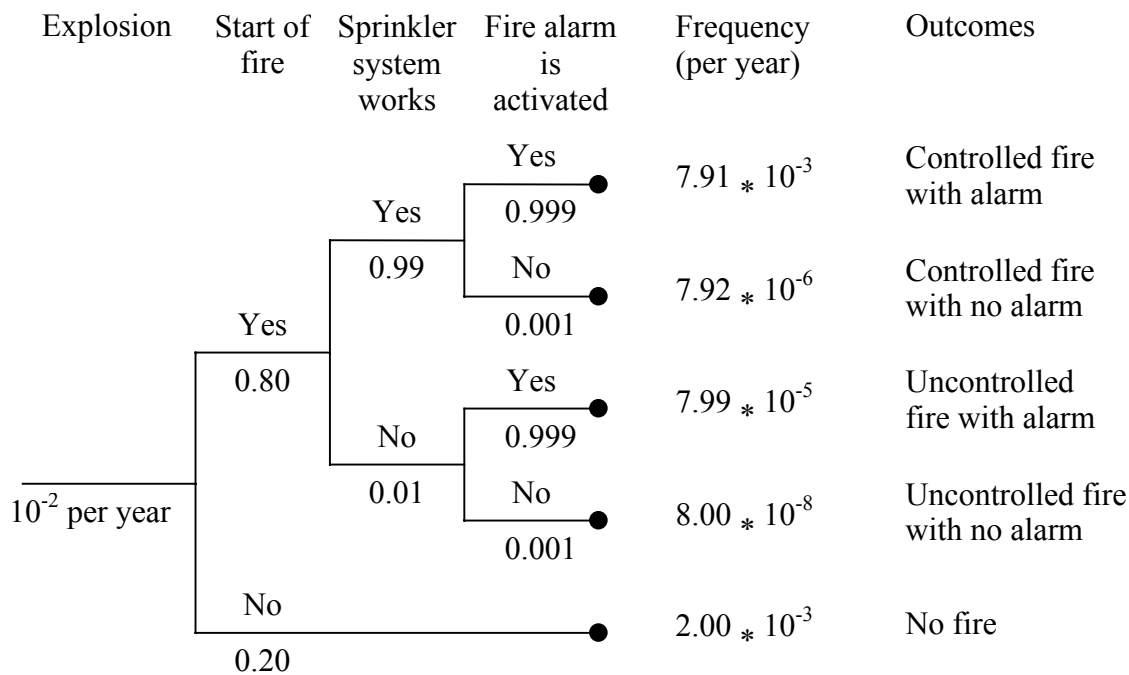

Figure 53. The event tree (binary case, explosion example).

The event tree is very effective in determining how various initiating events can result in accidents. On the other hand, the sequence of the events is analysed only for that initiating event. So to get an exhaustive risk analysis, the selection of the initiating events is a crucial task. Another limitation of ETA is the assumed independence of the events. In reality there is always some subtle dependencies (for example common components, operators...), that may be

overlooked in ETA. One more shortcoming of ETA is the "fail - not fail" -dictionomy, because systems often degrade without sudden failure.

Although ETA is mostly used to analyse accident scenarios, it can be applied for almost any type of risk assessment, especially when it is used together with PHA, HAZOP and FTA. One special application of ETA is Human Reliability Analysis. In this analysis (gross) human errors can be avoided by using ETA.

## 12.6 Fault tree analysis (FTA)

Fault tree analysis is one of the best and most used risk analysis methods. It is a deductive method, trying to answer to the question: "What causes...?" The idea of FTA is to go backwards from the failure or accident (so called **top event**) and trace all the possible events that can cause that top event, and then go on to the lower levels until the final level is reached and the basic causes are found.

Like any other risk analysis method, FTA starts with the description of the system (or project, process, etc.), where the fault tree is going to be applied. The bounds of the system and the level of complexity must be clearly defined.

The fault tree is constructed by using standard logical symbols. The most used symbols and their meanings are presented in figures 54 and 55. Although many more symbols exist, most fault tree analyses can be carried out using just four symbols (rectangle, circle, and-gate and or-gate).

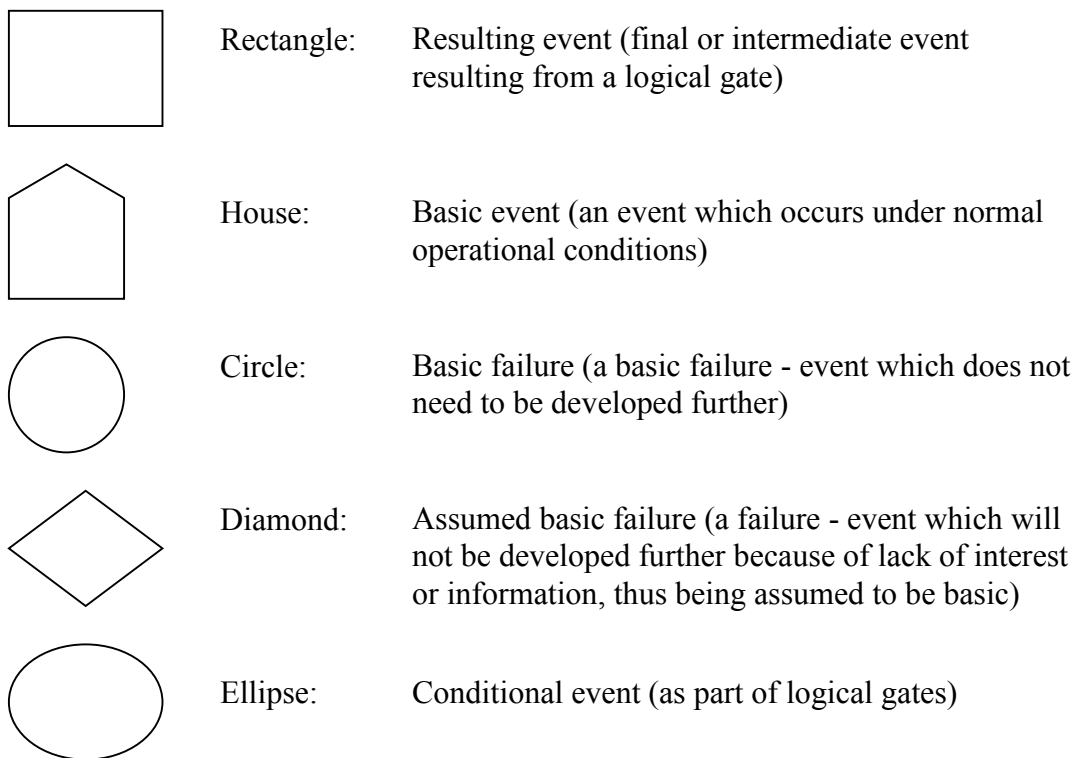

Figure 54. The basic symbols for events in fault tree analysis.

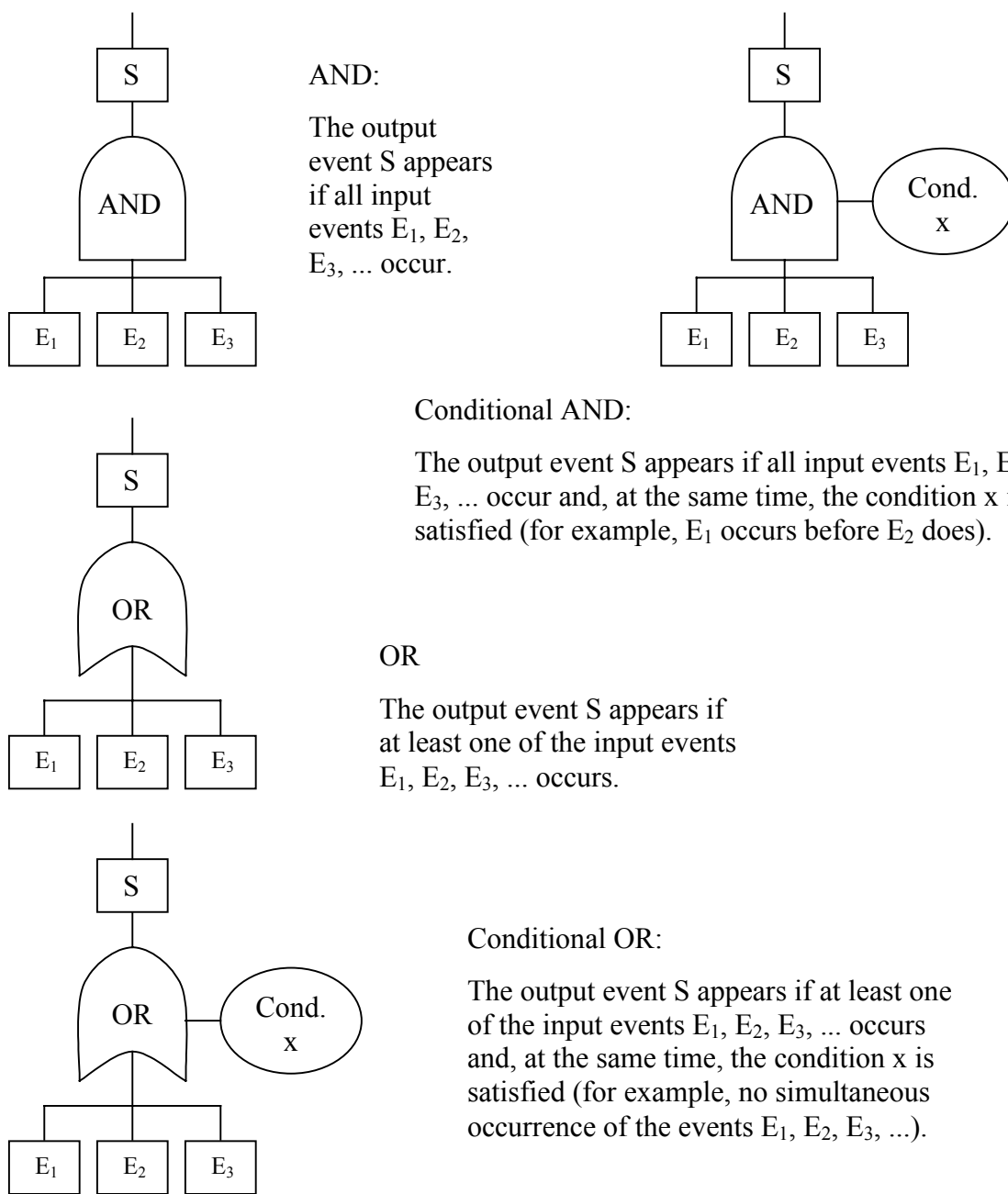

Figure 55. The basic symbols for logical gates in fault tree analysis.

The identification of the top event starts the construction of the fault tree. The top event is normally some undesired event, for example fire in a tunnel, falling of a worker from scaffolding, exposure to asbestos, cracking of an abutment etc. There are basically no strict rules for the definition of the top event, but the identification of the top event sets the framework for the elaborateness of the analysis. The process of constructing a fault tree is explained in figure 56.

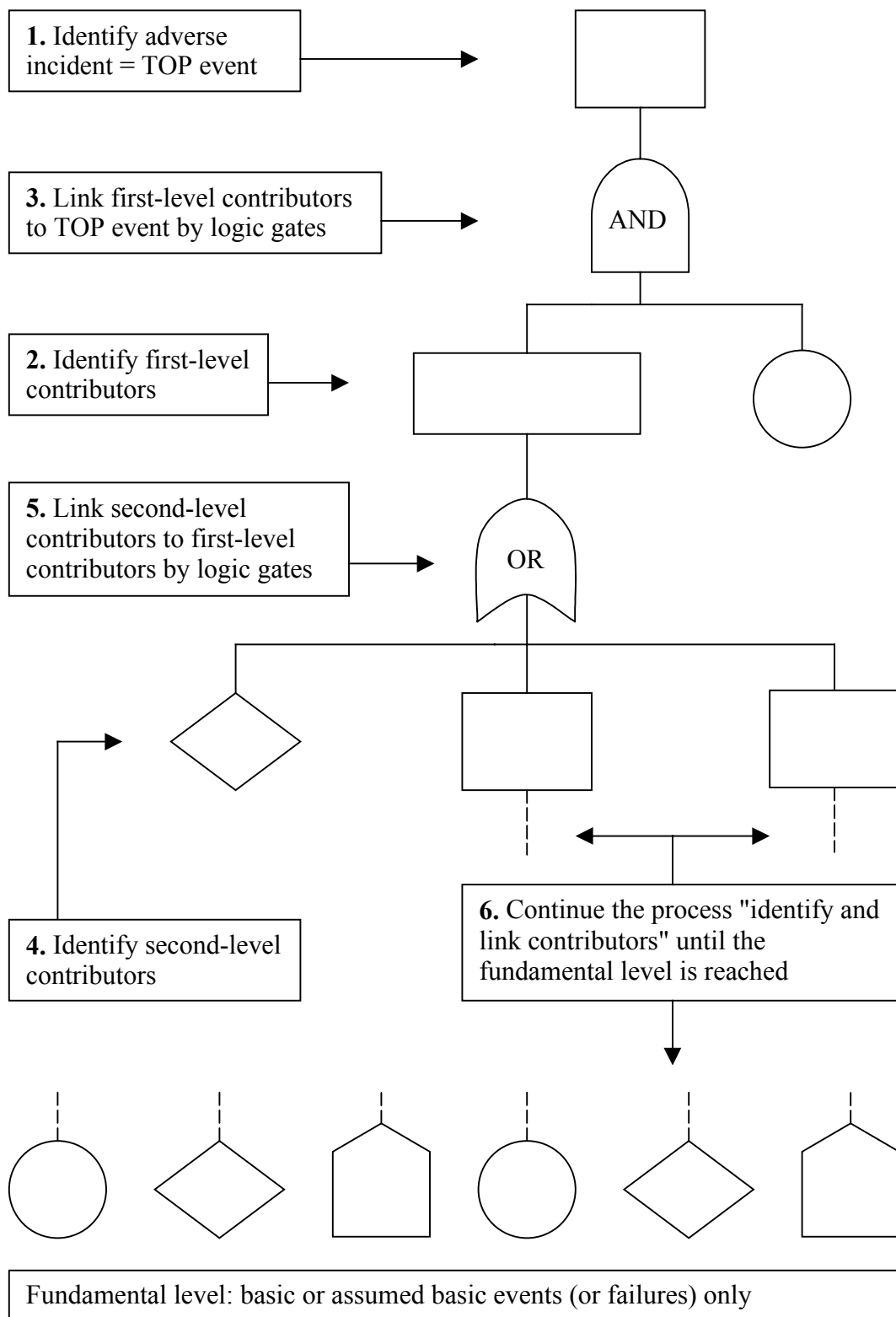

Figure 56. "Step by step" -construction of the fault tree. Note the order (numbers) of the steps.

FTA is very useful because it can take into account not just internal causes of the system, but also external factors like human carelessness, natural disasters and so on. FTA can be used qualitatively or quantitatively. For most cases the qualitative part of the FTA is enough, because the construction of the fault tree forces "the risk team" to improve their understanding of the

system characteristics, and most of the errors and hazards can be removed or reduced to acceptable level already in that phase.

In quantitative phase of FTA the target is to find the probability for the occurrence of the top event. The probabilities for the other events of the fault tree are evaluated, and using the **minimal cut sets** (the smallest combination of basic events which, if they all occur, will cause the top event to occur) the probability for the top event can be calculated very easily. The OR-gate represents *union* and the AND-gate represents *intersection*, and the probabilities are obtained by *summing* and *multiplying*, respectively. The mathematical expression of union and intersection is explained in figure 57.

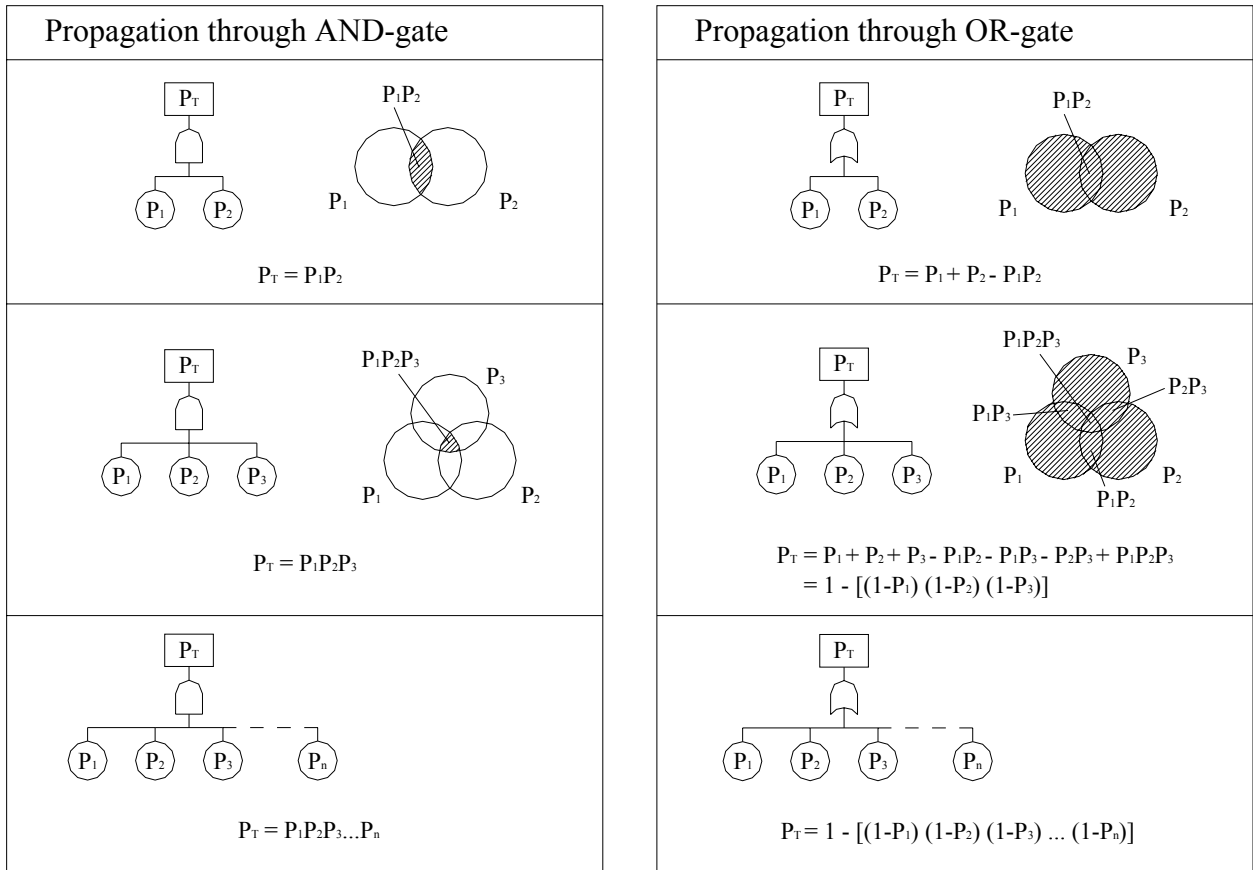

Figure 57. Mathematical expression of intersection (AND-gate) and union (OR-gate) in FTA.

As an illustration of the procedure from fundamental level to top event, a fictitious fault tree is constructed in figure 58, with fictitious probabilities of the basic (or assumed basic) events. The probability of the top event of this fictitious fault tree is calculated in figure 59.



Probabilities of the basic events:

- $P(E_1) = 0.001$
- $P(E_2) = 0.3$
- $P(E_3) = 0.2$
- $P(E_4) = 0.4$
- $P(E_5) = 0.07$
- $P(E_6) = 0.25$
- $P(E_7) = 0.1$
- $P(E_8) = 0.15$

Probabilities to be calculated:

$P(E_9) \dots P(E_{12})$   
and the probability  $P(E)$  of the TOP event E

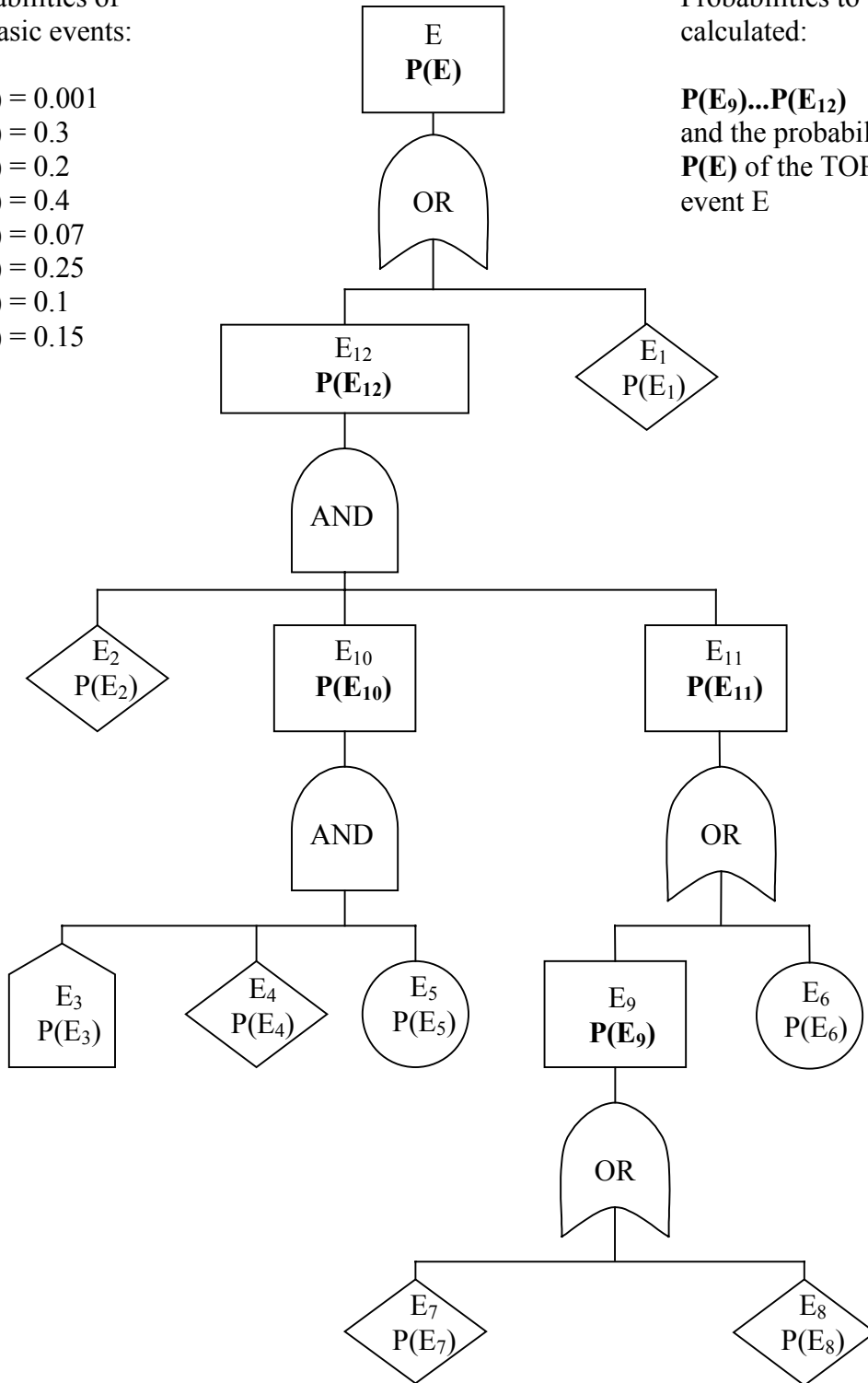

Figure 58. Illustrative example of a fault tree, with fictitious events ( $E_i$ ) and the probabilities of their occurrence ( $P(E_i)$ ).

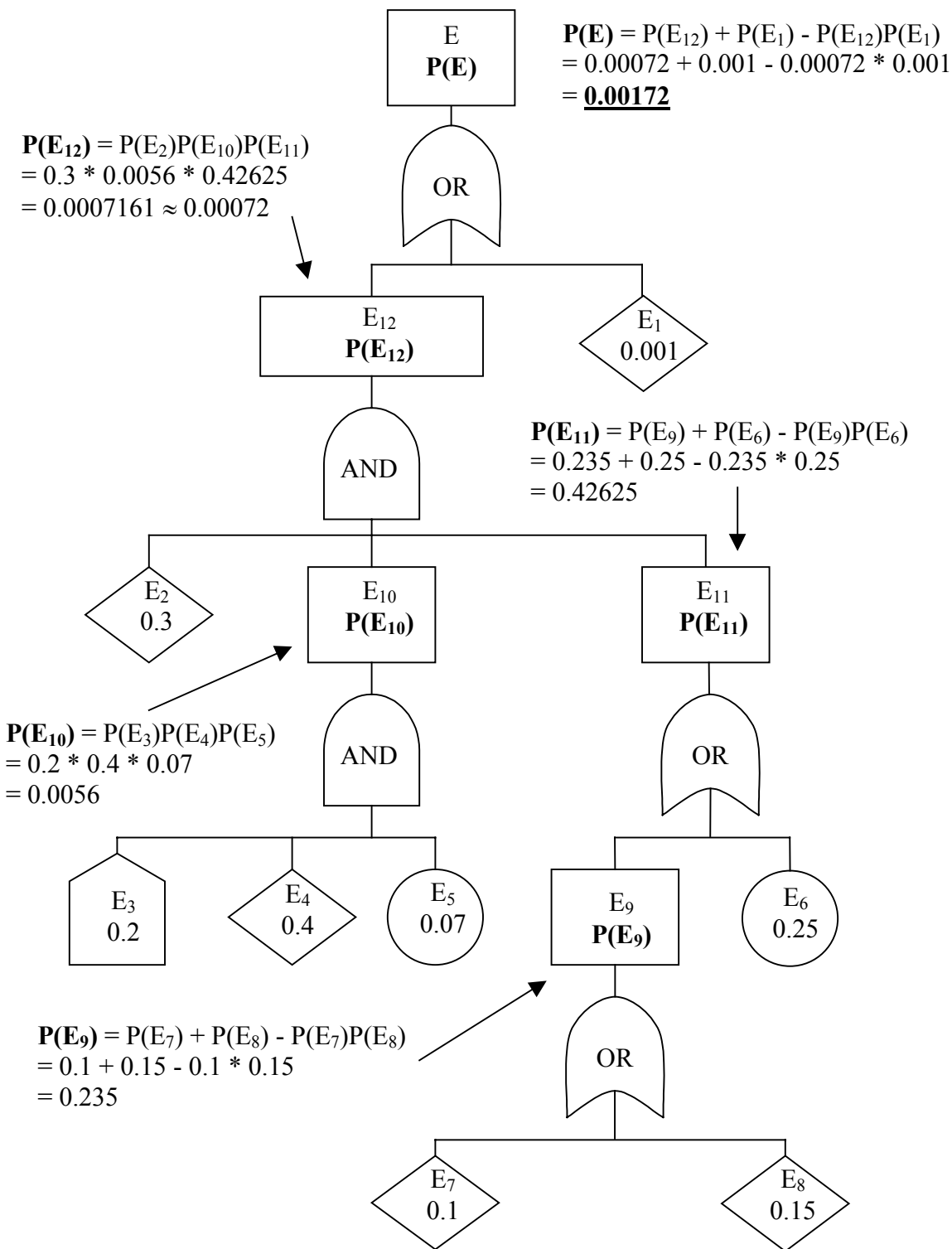

Figure 59. Calculation of the probability of occurrence of the top event (it is assumed, that the events (E<sub>i</sub>) are independent from one another) of the fault tree of figure 58.

FTA can be used for almost every type of risk assessment application, but it is used most effectively to find out the fundamental causes of specific accidents, where complex combination of events are present. FTA has (like any other risk analysis method) some limitations. It examines only one specific accident at a time, and to analyse the next one, another fault tree

must be created. This is expensive and time consuming. FTA is also very dependent of the analyst and his experience. Two analysts with the same technical experience will probably get different fault trees. Third drawback is the same as with all the other risk analysis methods, namely the quantification problem. It needs a lot of expertise, knowledge, effort, data, patience, etc.

However, carried out properly, FTA is extremely "readable" and it makes the causes and interrelationship very visible. As a consequence, the actions and corrections are easily channelled to where they are most needed.

## 13 Lifecon risk assessment and control procedure

### 13.1 Introduction

In Lifecon the subject risk is treated in a very wide scale. Not just structural risks, but also environmental, ecological, cultural and human risks are taken into account. The idea is to make facility owner **aware** of different risks throughout the whole lifetime of the facility, and to offer logical and easy procedure to deal consistently with them. Traditionally risk analysis has been used only in big construction or repair projects, but within Lifecon it is going to be an integrated information and optimisation tool in a predictive concrete facility management system. Change from traditional point-in-time effort to continuous process sets some requirements for the risk analysis module of the Lifecon LMS:

- the module must have an informative role (instead of checking up)
- the module must have a well-documented, updatable database structure
- the module must be powerful and extendable enough for future challenges
- the module must be compatible with other Lifecon decision making tools

Lifecon risk control proposal respects existing management systems. It does not demand abandonment of the old systems in order to work, but more likely offers a parallel system to be utilised with the old system. The biggest challenge for this risk control proposal is the implanting of new way of thinking that it brings along. While there do not exist normative limits in all Lifecon categories, it is up to the end user to decide which parts of the generic risk control proposal to exploit, in which extent and in which phases of the management process. The generic Lifecon viewpoint categories are presented in figure 60.

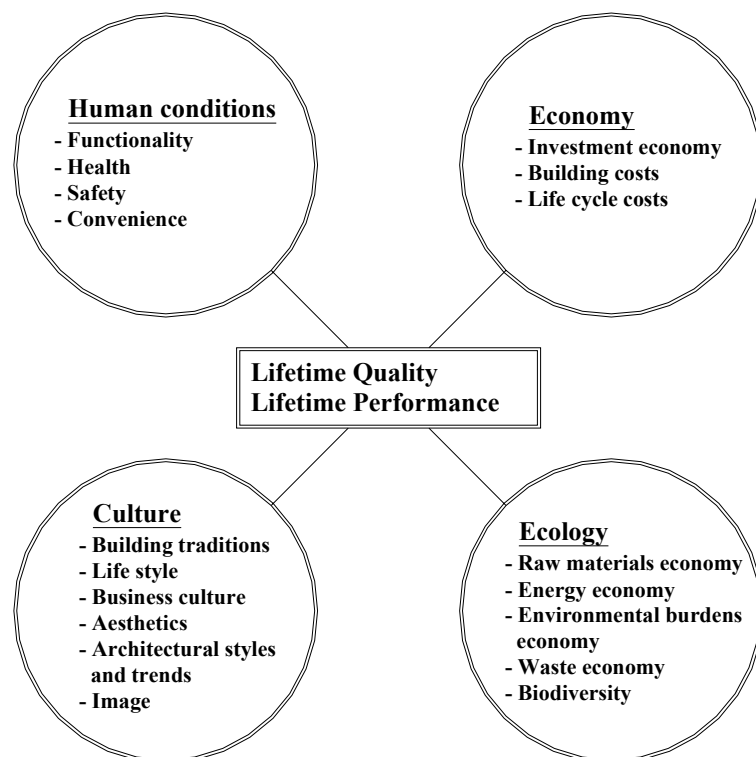

*Figure 60. Lifecon viewpoints and categories.*

## 13.2 The steps of the procedure

In short the Lifecon risk assessment and control procedure can be described with the following four steps, which are then explained in the sub-chapters.

1. Identification of adverse incidents
2. Analysis of the identified adverse incidents
  - deductively (downwards), in order to find causes
  - inductively (upwards), in order to find consequences
3. Quantitative risk analysis
4. Risk-based decision making (and continuous updating of risk database)

The steps 1, 2 and 4 are always performed if risk analysis is used, forming qualitative risk analysis. The step 3 is only performed if qualitative risk analysis is not enough for decision making *and* if quantification is possible.

A very important feature in the procedure is the continuance. Management of concrete infrastructures is a continuous process and new experience gained every day. The same applies to risk management. The steps described above form Lifecon risk management *loop* that is continuously maintained and updated, with strict documentation.

### 13.2.1 Identification of adverse incidents

The risk analysis starts with identification and listing of adverse incidents (threats, fears, unwanted happenings, mishaps), with regard to the whole lifetime of a facility or stock of facilities. Adverse incident means the same as top event in fault tree analysis (see chapter 12.6) or initiating event in event tree analysis (see chapter 12.5). For easy follow-up and updating, the identified adverse incidents should be logically labelled and stored into the database. "The whole lifetime of a facility" is too big a category, so smaller categories must be created. The lifetime of a facility is built up of a few functionally different, but chronologically overlapping or coinciding phases. While identifying adverse incidents, also the phase - i.e. the moment when the adverse incident can happen - is automatically identified. A logical categorisation of adverse incidents follows those functional phases, which are normally

- every day use
- inspection and condition assessment
- MR&R actions
- extremities (high floods, exceptional snow loads, collisions, high overloads etc.)

Of course facility owner can categorise the identified adverse incidents differently, according to his/her own preferences. In theory there is no limit for the number of categories, but easily the database becomes cumbersome, if the number of categories increases too much.

It is not *only* facility owner's task to identify adverse incidents. Incidents are best identified by those who deal with them in their every day work, i.e. contractor can help in identifying adverse incidents connected with MR&R actions, inspectors are suitable persons to identify the mishaps at inspection work, and so on. In addition to instinct and experience, information about possible adverse incidents are gathered from statistics, research, expert opinions, statistics, accident

reports, failure logs, MR&R data, monitoring data, material tests, material producers, future studies, etc.

The importance of *rationality* in identification of adverse incidents cannot be overemphasised. The idea is not to create horror scenarios, but to answer *reasonably* to the first question of risk analysis: "What can go wrong". In Lifecon this means "What can go wrong in the management of a concrete facility, during its whole lifetime". Possible adverse incidents to be identified in this first step could be for example (functional phase in brackets):

- inspector hit by a car (inspection and condition assessment)
- falling from road bridge in every day use (every day use)
- exceeding of limit state in spite of LMS system (every day use)
- exceeding of MR&R budget (MR&R actions).

### 13.2.2 Analysis of the identified adverse incidents

After the adverse incidents are identified, they are analysed further. The goal of this second step of Lifecon risk control procedure is twofold: firstly to find the underlying *causes* of the adverse incidents, and secondly to find the *consequences* of the adverse incidents. The result - unbroken nexus of events from causes to consequences - forms a structured skeleton that helps decision-maker to perceive causalities and logic of the risk problem at hand. This step is the most important in the whole risk analysis process and that is why it should be made very carefully. The sources of information for construction of the skeleton are the same as in step one. It must be noted that risk analysis is not "one man's show", but requires multi-discipline expertise.

The downward analysis - to find causes for the identified adverse incidents - is made using fault tree analysis (FTA). As explained in chapter 12.6, the primary factors that lead up to top event (i.e. adverse incident) are looked for. The intermediate events are linked with corresponding logic gates, until the desired fundamental level is reached. The desired fundamental level depends on the end user. For example, for one end user it can be enough to know that there happens approximately one severe car accident on a certain bridge every year, while another one wants to go further and find out why the accident frequency is so high.

The structure of a fault tree is illustrated in figure 61. The top event refers to the adverse incident example from step one, namely the "falling from road bridge". The standard forms of FTA drawing objects are explained in chapter 12.6.

The fault tree of figure 61 is presented only for illustrative purpose. The idea is to show what a fault tree looks like and how it can be utilised. The depth of the analysis is stopped to a level that satisfies the fictitious decision-maker. At first glance the leftmost branch in figure may seem strange. Why should facility owner worry about intentional falling? The answer is that if the number of falling accidents is relatively high, the authorities may require some explanations. Consequently, if it is revealed that the bridge for some reason tempts people to climb on the railings, the authorities may demand immediate actions to impede climbing. For example, in high rise buildings, lighthouses etc. the access to the top is normally controlled, whereas with bridges the access is (logically) free.

In figure 61 the two branches on the right are not developed further, because the fictitious decision-maker is not interested in traffic accident induced fallings or fallings during MR&R works, but wants to focus only on fallings under normal circumstances, in every day use.

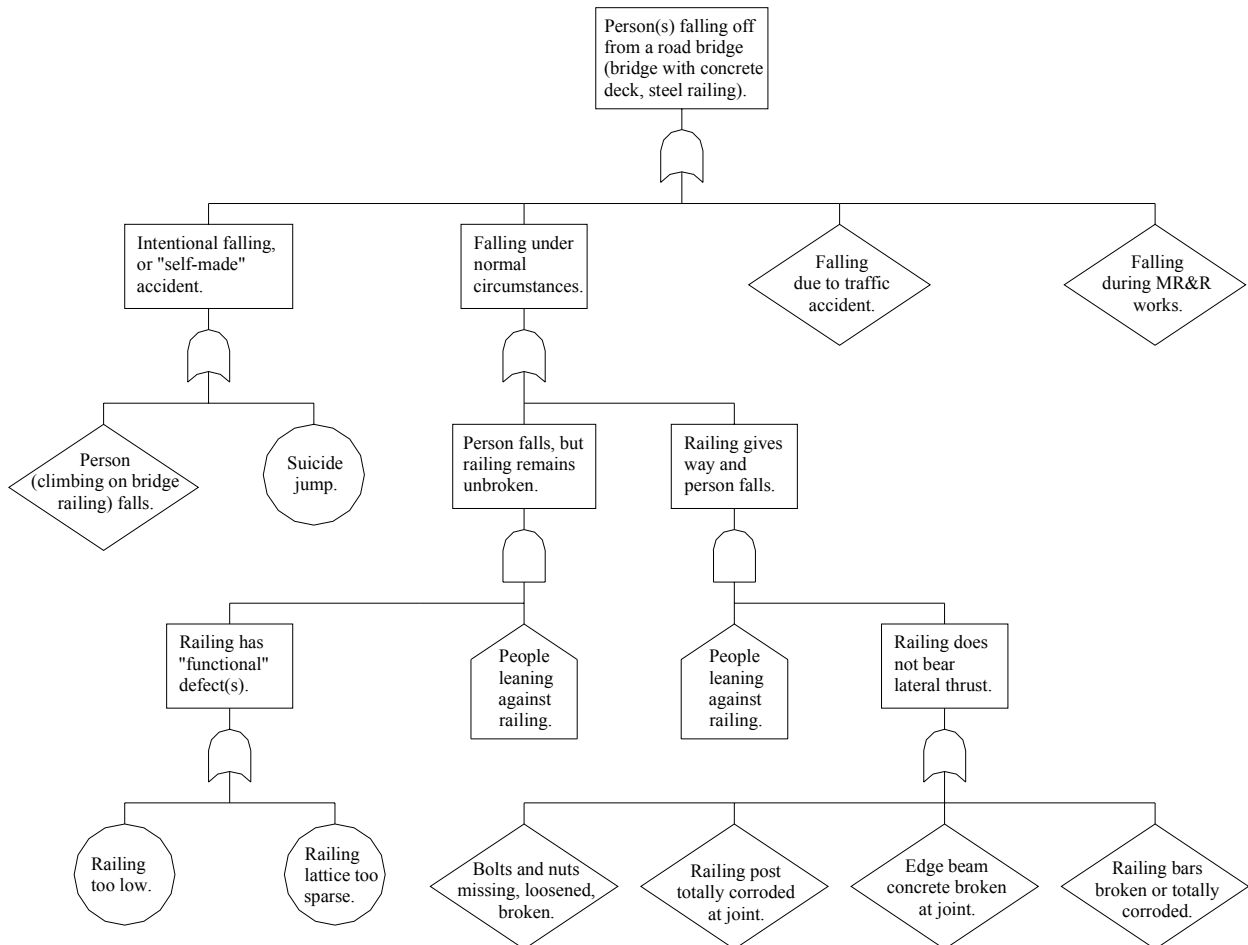

Figure 61. Illustration of a fault tree.

The upward analysis - to find consequences for the identified adverse incidents - is made using event tree analysis (ETA). As explained in chapter 12.5, the goal of event tree analysis is to find consequences and final outcomes for initiating event (i.e. adverse incident). In Lifecon the consequences are divided in four main categories, which are

- human conditions
- culture
- economy
- ecology.

The four main categories are further divided into sub-categories, see figure 60. In Lifecon risk control procedure all these categories are examined (one by one) when finding out consequences for the identified adverse incidents. Once again it is up to the facility owner to decide, how strictly the general Lifecon categorisation is complied with, when looking for consequences. For

example, one facility owner may be interested only in direct economic consequences, whereas a more conscious facility owner takes into account also the consequences for culture. Of course all adverse incidents do not necessarily have consequences in all Lifecon categories.

The event tree analysis in Lifecon is not as exhaustive as fault tree analysis described above. Normally after one or two nodes the final consequences can be reached. Sometimes the identified adverse incidents are incidents that must not happen (collapse of main girder, pollution of ground water, fire in tunnel, etc.). In such cases the fault tree analysis is enough, revealing causes of the incident, and if the top event probability is too high, decision must be made to lower the probability.

An illustration of a possible event tree is presented in figure 62. The consequences of falling result mainly from safety category because the repair costs of a railing are almost nil compared to possible compensations in case of death or permanent injury. Falling from bridge can induce consequences also in culture category, if for example the 100-year-old decorated railing is found to be the cause of the falling and consequently authorities demand that the old railing must be replaced by a modern standard railing.

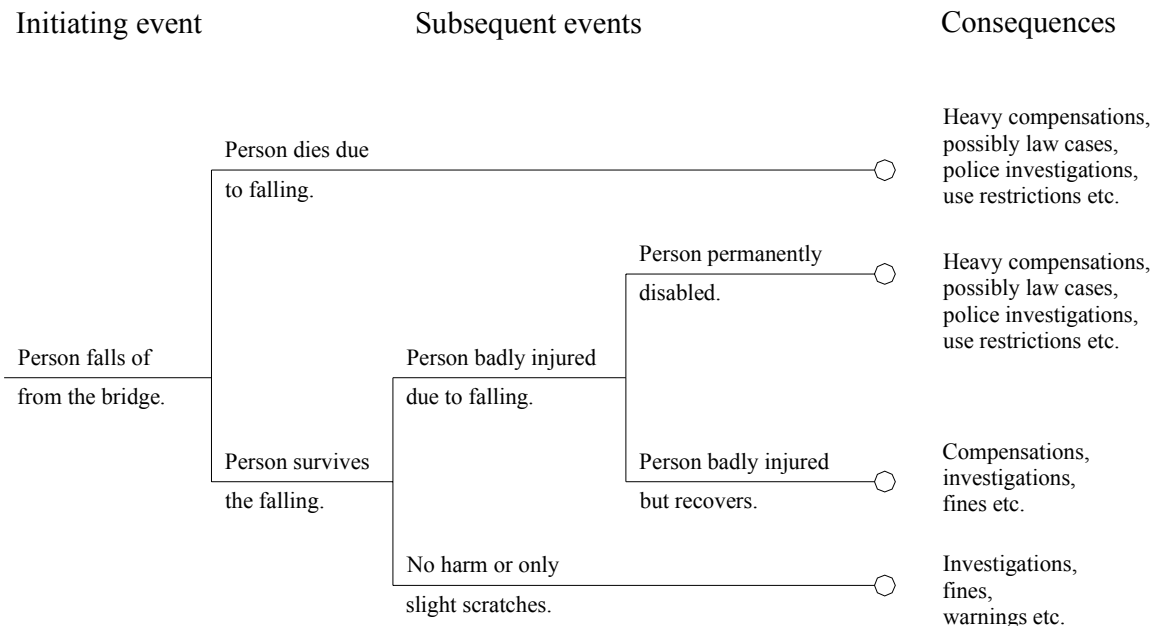

Figure 62. Illustration of an event tree.

The first two steps described above, i.e. the "identification of adverse incidents" and the "analysis of the identified adverse incidents", are enough if risks are treated qualitatively only. With the aid of a visual, logical causes-consequences structure a facility owner can in most cases estimate the risk and make a consistent decision, even if no numbers are presented in the analysis.



### 13.2.3 Quantitative risk analysis

If the qualitative risk analysis - described in steps one and two above - is not enough, a quantitative risk analysis must be performed. The quantitative risk analysis utilises the same fault and event tree skeletons that were created in step two above.

In this quantitative phase, estimations about probabilities of basic events (or assumed basic events or failures, see figures 54 and 56) are added to the fault tree part of the analysis. Likewise, in the event tree part of the analysis, estimations about the probabilities of the subsequent events (see figure 51) are added to the event tree skeleton. The initiating event probability of ETA is the same numerical value that is obtained as a result from the fault tree analysis, i.e. top event probability of FTA.

Because risk is defined as the product of probability and consequence, mere estimation and calculation of probabilities is not enough in calculating risk. Also the consequences must be evaluated numerically. In Lifecon, consequences of very different categories (figure 60) are taken into account, so there is no commensurate unit for all these different consequences. However, in practice the *very final* consequences are always calculated using some monetary unit. That is also the Lifecon approach: in this quantitative phase of risk analysis, all the ETA consequences generated in the qualitative phase are estimated in euros. In estimation of probabilities and consequences, the same sources of information are of help as in qualitative analysis, i.e. statistical data, experience and subjective opinions of experts. It must be noted that if quantification is not possible, quantitative risk analysis should not be requested at all.

In literature (and also in chapters 12.5 and 12.6) the quantification is usually presented using deterministic values for probabilities. However, in reality it is impossible to give exact numerical values for uncertain probabilities and consequences. For that reason the use of distributions and simulation is preferred in this quantitative part of Lifecon risk procedure. When giving estimates for probabilities and consequences, it is much easier to find a range of possible values instead of one consensual value. In FTA part the basic probabilities are expressed with appropriate distributions and after that the top event can be calculated using simulation. Likewise, in ETA part the numeric values for subsequent events and consequences are expressed with distributions. Then, using top event probability of FTA as the initiating event probability of ETA, the risk can be calculated with the aid of simulation. The result is of course a distribution, as all the input parameters are distributions.

In appendix A the whole quantification procedure is presented for the step one adverse incident, namely the "falling from road bridge". The quantification example is illustrative only, as the numeric values for probabilities and consequences are quite arbitrarily invented. In the example the consequences have been estimated only in "Safety" sub-category, which belongs to "Human conditions" main category. In full Lifecon risk procedure also the other categories should be examined for possible consequences. On the other hand, consequence costs of "falling from road bridge" accumulate mostly from that "Safety" category.

### 13.2.4 Risk-based decision making

When the identified adverse incidents have been analysed and risks estimated (qualitatively or quantitatively, according to need), risk evaluation can be performed. In this phase judgements are made about the significance and acceptability of the risks, and finally, decisions are made on how to deal with the risks.

In this phase all the adverse incidents should be already analysed and stored into the risk database with documentation. If the analyses described above are performed in Lifecon extent, there should be risks in all four main categories and their sub-categories. If quantitative analyses have been performed for the adverse incidents the risks can be summed category-wise. If only qualitative risk analysis has been performed, still the number of adverse incidents that have impact on a certain Lifecon consequence category is easily obtained. With normal database commands the primary factors of these risks in certain category can be easily listed, and consequently they can be dealt with.

If the risk is acceptable, it is enough that the decision-maker is aware of the risk attendant upon the decision, but the evaluated risk does not have to be reduced. The decision is then made according to Lifecon decision making procedure. Whether the risk is in that case one of the factors having impact on the decision, is up to the end user. If the risk is estimated and evaluated quantitatively, it can be easily included to the decision tree or MADA as a criterion. In decision tree the limit for risk criterion is decided by the end user and in MADA the impact of risk is taken into account by giving appropriate weight to the risk criterion.

If the risk is not acceptable, further considerations must be made. Basically, there are four options to choose from:

- lowering the probability of the adverse incident
- reducing the consequences of the adverse incident
- rejecting the risk
- transferring the risk

The best option is to lower the probability of the adverse incident. With visual causes-consequences structure (created in step two of the Lifecon risk procedure, see chapter 13.2.2) it is easy to see, which factors affect the top event, and consequently effort can be effectively directed to the problematic factors. If quantitative risk analysis has been performed, the allocating of efforts is even easier, because sensitivity analysis reveals automatically the biggest contributors to the top event.

Another way of reducing risk is to reduce the consequences of the adverse incident. Sometimes it can be easier to accept relatively high probability of adverse incident and create safeguards against severe consequences than to overspend resources in trying to reduce the probability. For example, input errors - when inserting information manually into any system - are unavoidable, but the system can be created so that one input error does not affect the system. Floods cannot be easily prevented, but an old stone bridge in weak condition can be closed for the flood peaks to avoid casualties, etc.

Rejecting risk in this context means rejecting an option in which unacceptable risk is involved. In Lifecon decisions are normally made between different alternatives, so rejecting one alternative because of too high risk can be very usable means in Lifecon decision making process.

Risk transfer is used a lot but it cannot be recommended, if sustainable development is to be emphasised. If this means is chosen, the risk itself does not diminish at all, only the responsibility is transferred to another party. In practise risk transfer means taking out insurance against the risk.

Whatever the risk-based decision is, it must be well documented (who made the decision, what were the circumstances, etc.). By this means the quality of the decision can be followed up and improvements and updatings made to the fault tree and event tree analyses for future needs.

### **13.3 Using Lifecon risk assessment and control procedure in practice**

In theory all problems that involve uncertainty are best solved with risk analysis approach, but in Lifecon approach risk analysis forms only a part of the decision making and optimisation procedure. The reason for this is quite clear: many time-dependent phenomena (e.g. corrosion or carbonation) are studied and modelled accurately, and those models are or are being widely approved. However, in concrete facility management there exist a lot of moments where suspicion arises but no models are available. In these situations risk analysis approach is best applied. For example, in the following hypothetical decision making situations risk analysis can offer help:

- Bridge is always congested but in very good shape. Suspicion: Is it safe for the users or should it be widened or replaced with a broader one?
- Old bridge seems to be in good condition, but in the same subsoil area settlements of abutments have been reported. Suspicion: Is there a danger of settlement with this bridge also?
- A certain MR&R method works perfectly in one country and is used a lot there, but has not been used in another. Suspicion: Is the method applicable in this other country also, or should the facility owner keep using the traditional method?
- Long dark underpass in a suburb always full of graffiti, otherwise the condition is good. Suspicion: Do the image and worth of the area suffer and do people have uneasy feeling because of the old underpass, and consequently should the underpass be modified?
- Old building needs rehabilitation urgently, but should the façade be replaced with the same method and materials as were used when first built? Suspicion: The old building is very dear for people, and strong modifications can raise resistance.

In Lifecon, decision making and optimisation is performed on two hierarchical levels, i.e. the network level and the object level. Network means the whole stock of facilities, e.g. all the bridges owned by community or road administration, all the tunnels, all the lighthouses, etc. Object means logically one of these facilities: a certain bridge, a certain tunnel, a certain lighthouse. As can be seen in the examples above, risk-based decision making is best applied on object level, because only then all the local factors can be taken into account. When the identified adverse incidents are analysed using the presented Lifecon risk procedure, there will be found also causes that can and should be treated on network level (e.g. low quality of

inspection, bad safety policy, difficult data storing system, etc.). However, sensitivity analyses always show that object level factors contribute more to the probability of adverse incidents than network level causes.

Given that *risk* is very case sensitive variable and depends a lot on the facility owner's company strategy and preferences, a lot of responsibility is left for the end user in implementing the Lifecon risk procedure. Only general guidelines can be given about how the risk procedure can be *introduced* and how it can be *used* in the long run (maintained and updated). The prerequisite for successful risk management is that it will be taken seriously as any part of management, and that there are enough resources reserved for risk management. The corporate strategy and preferences concerning the Lifecon risk consequence categories (human, cultural, ecological and economical) and the risk acceptance levels in those categories should be clarified already at the outset. Also, it must be decided before the analyses, *how* the results will be used: is *category-wise risk* going to be only one criterion in MADA among the other criteria, or is it going to be used separately like veto, what is the importance (or weight) of risk in decision-making etc.

The Lifecon risk assessment and control procedure should be introduced first only on object level, taking some *well-studied object* as a pilot example. Then the first two steps of the Lifecon risk procedure should be performed as extensively as possible. In finding out causes and consequences, innovation and imagination should not be restricted but rules of FTA and ETA should be followed. When the qualitative analyses are ready, the contributors and consequences of the identified adverse incidents are ready to be quantified. This next step (quantification) is the giant one and the reason why a well-studied object was chosen to be a pilot example. Normally some estimates can be found, but for most of the contributors even a guess can be difficult to get. However, this very moment of helplessness is a positive improvement to present practise: the end user is forced to see these weak (or blank) points in his maintenance and management policy! Consequently, he should revise the analyses, cut off the most improbable (or almost impossible) scenario branches, and after trimming the logical trees allocate his effort to the problematic contributors and scenarios.

Finally, the end user makes the decision and compares it with the decisions made in reality. If there is a lot of difference in the decisions, the reasons should be studied. Finding of reasons can be difficult, because in real life the decisions may not be documented, or the company has a written strategy, but it is not necessarily followed very accurately in practice etc. An important point to be remembered all the time is that in management of concrete infrastructures reasonable and optimised decisions have been made during years without Lifecon risk approach, so big differences normally indicate that the *new system* needs adjustments.

At the outset of establishing the Lifecon risk assessment and control procedure, the depth of the analyses will certainly be on a rather general level, because the system can not be introduced, installed, established and verified in a day. But when the fault and event trees exist and more information flows in, these analyses will get more detailed and consequently the results more accurate. However, at best the process of establishing and adjusting the new system will take years and needs a lot of patience and commitment.

### 13.4 Qualitative or quantitative risk analysis; Discussion

In many cases of management troubles the qualitative evaluation of risks is enough for decision making. The qualitative evaluation shows the weakest links and areas to the facility owner, and counsels him to put more effort into solving problems on those areas. The routines (modelling, inspections, MR&R actions, etc.) are basically well established, and if some deviations from the plans occur, they are most probable due to human activity (negligence, carelessness, etc.). Unfortunately, in the management (and especially with MR&R actions) of concrete facilities human labour is needed in all phases, and unlike with machines and processes, the human behaviour in different situations is very difficult to predict.

If there is no real need or possibility to get exact numbers for risks, then the heavy-scale quantitative risk analysis should not be carried out. Qualitative analysis and comparative estimations are more reliable and readable than absolute values, especially when single numbers are used instead of distributions in quantification. It should always be remembered that running a rigorous quantified risk analysis is extremely expensive at present (mostly due to lack of consistent source data) and in normal cases out of question in maintenance policies.

So far there have not been demands for the quantitative risk analyses from the authorities in maintenance sector, but the trend is in favour of more accurately calculated and explained decisions and in the future quantitative risk analyses can be some kind of routine. For example, in off shore oil industry there are already regulations about quantitative risk analysis. However, the quantified analyses in oil industry are not applied as extensively as is the goal of Lifecon (economical, ecological, human and cultural aspects), but have concentrated more on the human safety and environmental issues.

Applying qualitative risk analyses in the maintenance policy will be an improvement to the present day practise. The risk procedure proposed above does not require any miracles or higher wisdom from facility owners, when used in *a qualitative way*. In addition, by applying FTA- and ETA-based qualitative risk analysis to the management policy already now the facility owner can prepare for the future, because this qualitative phase always precedes the quantitative analysis.

The qualitative risk analysis vs. quantitative risk analysis is a topic for endless discussion. This topic was already briefly touched in chapter 11.3 where some problems were brought out as an introduction to the whole risk discipline. Of course decisions are easier to explain and justify if they are based on numeric facts. Unfortunately in construction sector these numeric facts have not been easy to find. Methodologies exist but without appropriate numeric input they do not give consistent numeric results. On the other hand, the qualitative versions of risk methods can be applied already with good results, but they do not help decision-makers who are playing only with numeric values.

## 14 References

- [1] Thoft-Christensen P., Faber M.H., Darbre G. and Høj N.P., *Risk and Reliability in Civil Engineering - Short Course*, Lecture Notes. Zürich 2001.
- [2] James M. (Ed.), *Risk management in civil, mechanical and structural engineering*, Conference Proceedings, Thomas Telford, London 1996.
- [3] Rissanen T., *Probabilistic Traffic Load Model Applied Especially to Composite Girder Bridges*, Master's Thesis, Espoo, 2001. (in Finnish)
- [4] Modarres M., *What Every Engineer Should Know About Reliability and Risk Analysis*, Marcel Dekker, Inc., New York, 1993.
- [5] Goldberg B.E., Everhart K., Stevens R., Babbitt III N., Clemens P. and Stout L., *System Engineering "Toolbox" for Design-Oriented Engineers*, NASA Reference Publication 1358, 1994.
- [6] Vose D., *Quantitative Risk Analysis: A Guide to Monte Carlo Simulation Modelling*, John Wiley & Sons, Chichester, 1996, 328 pp.
- [7] Wang J.X. and Roush M.L., *What Every Engineer Should Know About Risk Engineering and Management*, Marcel Dekker, Inc., New York, 2000.
- [8] Faber M.H., *Risk and Safety in Civil Engineering, Lecture Notes*, Swiss Federal Institute of Technology, 2001.
- [9] *Risk Assessment and Risk Communication in Civil Engineering*, CIB report, Publication 259, March 2001.
- [10] *Safety, Risk and Reliability - Trends in Engineering*, Conference Report, Malta, March 2001.
- [11] Sarja A., *Integrated Life Cycle Design of Structures*, Spon Press, London, 2002, 142 pp.
- [12] Söderqvist M.-K. and Vesikari E., *Generic Technical Handbook for a Predictive Life Cycle Management System of Concrete Structures (LMS)*, Lifecon Deliverable, draft, 2003.
- [13] Lair J. and Sarja A., *Multi-Attribute Decision Aid Methodologies*, Lifecon Deliverable, draft, 2003.

## Appendices

### A. Illustrative example of Lifecon risk quantification procedure

In this appendix an example of the quantitative use of Lifecon risk procedure is presented. The adverse incident to be further analysed is "falling from road bridge". The bridge has concrete deck and steel railing.

The steps to be taken in this quantification phase are:

1. Estimation of probabilities of events in fault tree
2. Estimation of probabilities of events in event tree
3. Estimation of numeric values for consequences in event tree
4. Calculation of the probability of top event in fault tree
5. Calculation of the expected costs in case of falling
6. Combining of fault tree and event tree calculations to obtain the value for risk.

In this example the risk is calculated both in deterministic way and probabilistic way in order to show the difference between the two approaches. The deterministic calculations are performed using normal spreadsheet software (Excel), but for the probabilistic calculations simulation is used. In this example the simulations are performed using software called @RISK, which is an add-in programme to Excel.

#### 1. Estimation of probabilities of events in fault tree

The fault tree used in this quantification phase is the one presented in figure 61. The probabilities must be estimated for the diamond, circle and house symbols. Rectangle values are then calculated according to principle presented in figure 57. For easier follow-up of calculations, the fault tree of figure 61 is re-drawn and re-coded in figure A1.

The probabilities for diamond, circle and house events, presented in table A1, are illustrative only. In true case they could be very different, like the fault tree itself, depending on the case.

Table A1. Illustrative frequency values for fault tree example.

Frequency values for P <sub>1</sub> ...P <sub>13</sub> (basic events, basic failures or assumed basic failures)		
Event	Deterministic value	Probabilistic value (distribution with parameters, standard format)
P <sub>1</sub>	0	0
P <sub>2</sub>	0	0
P <sub>3</sub>	0.08	Extvalue (0.07, 0.018, truncate (0, 0.2))
P <sub>4</sub>	0.01	Extvalue (0.007, 0.005, truncate (0, 0.2))
P <sub>5</sub>	1	1
P <sub>6</sub>	0.008	Extvalue (0.006, 0.0035, truncate (0, 0.1))
P <sub>7</sub>	0.007	Extvalue (0.005, 0.0033, truncate (0, 0.15))
P <sub>8</sub>	0.002	Uniform (0, 0.004)
P <sub>9</sub>	0.004	Uniform (0, 0.008)
P <sub>10</sub>	0.001	Triang (0, 0.001, 0.002)
P <sub>11</sub>	0.001	Triang (0, 0.001, 0.002)

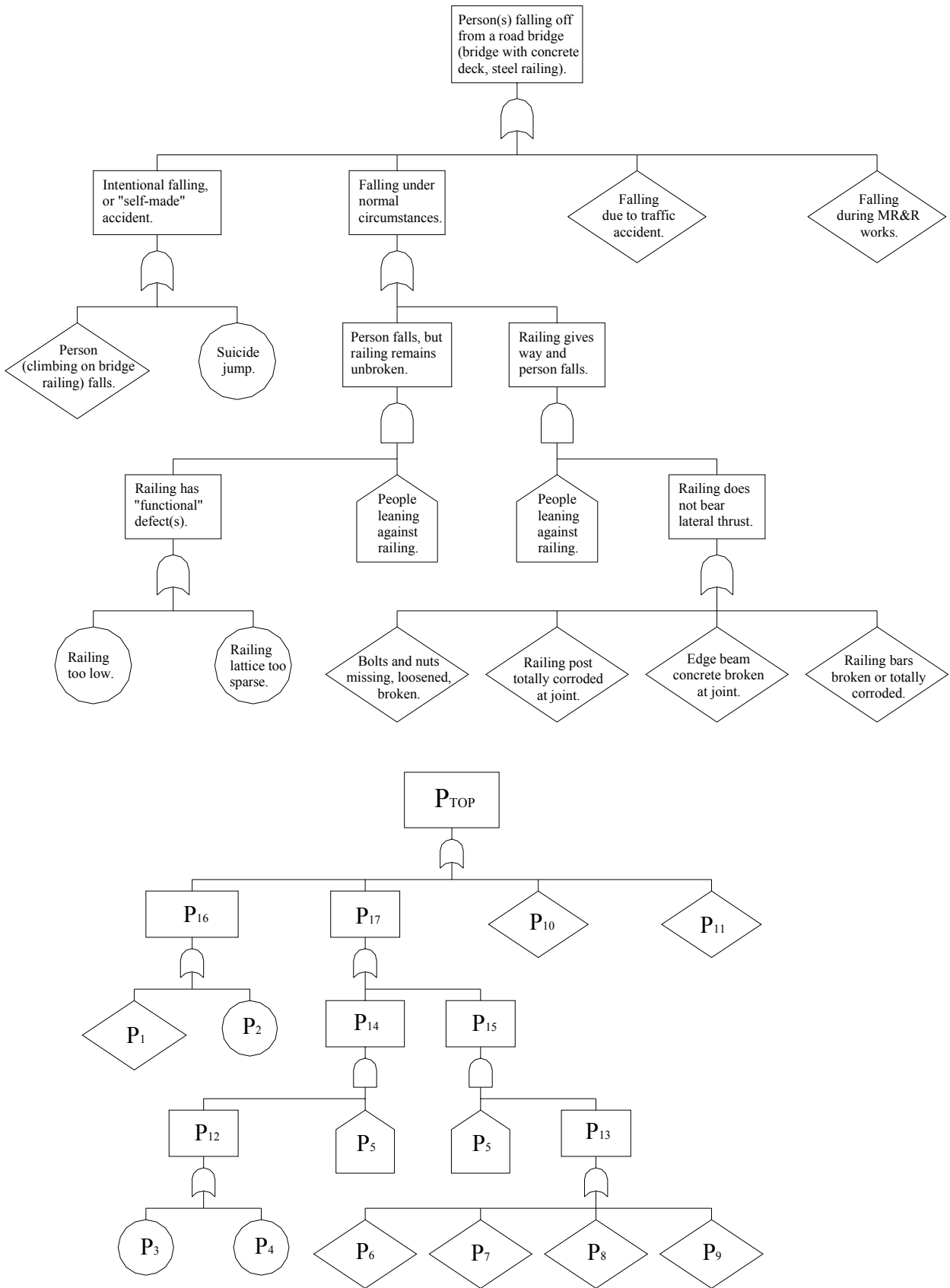

Figure A1. Abbreviations for the fault tree events. The P's stand for probabilities of the corresponding events. The logic of numbering order is from left to right and from basic events - diamond, circle, house - through intermediate events to top).



## 2. Estimation of probabilities of events in event tree

The event tree used in this quantification phase is the one presented in figure 62. In that figure is presented four possible final outcomes from falling. Those outcomes are

- Person dies
- Person remains permanently disabled
- Person injures badly, but recovers
- Person gets only scratches or no harm at all

Figure 62 is re-drawn for easy follow-up in figure A2. The three subsequent events are numbered  $E_1 \dots E_3$  and their outcome options  $E_{11} \dots E_{32}$ . The outcome probabilities for these subsequent events are presented in table A2. The probabilities are illustrative only.

Table A2. Outcome probabilities for subsequent and final events of event tree.

Outcome probabilities of subsequent events, <i>in case the falling has happened.</i>			
Event	Path	Deterministic value	Probabilistic value (distribution with parameters, standard format)
$E_1$	$E_{11}$	0.1	Uniform (0,1) ; if $>0.9 \Rightarrow$ path $E_{11}$ is chosen, otherwise $E_{12}$
	$E_{12}$	$1 - E_{11} = 0.9$	
$E_2$	$E_{21}$	0.9	Uniform (0,1) ; if $>0.9 \Rightarrow$ path $E_{22}$ is chosen, otherwise $E_{21}$
	$E_{22}$	$1 - E_{21} = 0.1$	
$E_3$	$E_{31}$	0.2	Uniform (0,1) ; if $>0.8 \Rightarrow$ path $E_{31}$ is chosen, otherwise $E_{32}$
	$E_{32}$	$1 - E_{31} = 0.8$	

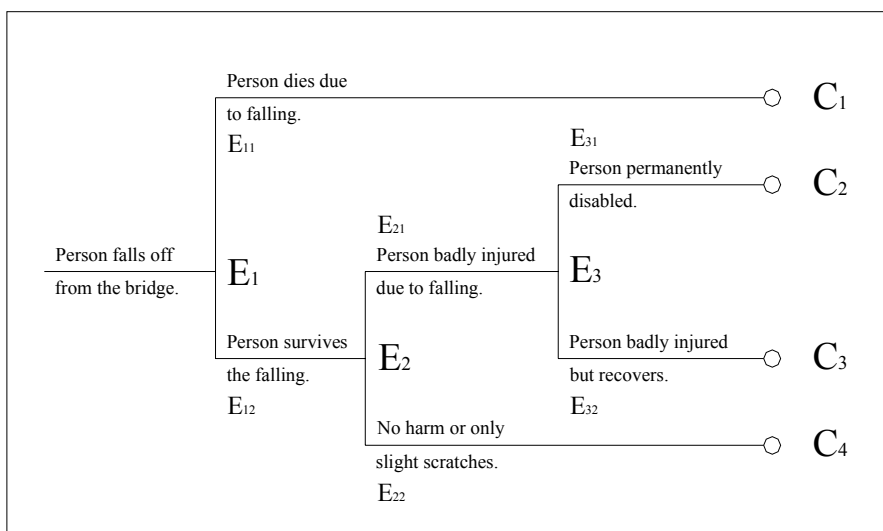

Figure A2. Event tree example, with events and outcomes numbered.

## 3. Estimation of numeric values for consequences in event tree

The outcomes shown in figure A2 are:

- $C_1$  - Person dies
- $C_2$  - Person remains permanently disabled
- $C_3$  - Person injures badly, but recovers
- $C_4$  - Person gets only scratches or no harm at all

In table A3 below the consequences are numerically estimated, and once again, the numbers are more or less arbitrary and illustrative only.

Table A3. Illustrative values for consequences.

Consequence values (€) for C <sub>1</sub> ...C <sub>4</sub>		
Event	Deterministic value	Probabilistic value (distribution with parameters, standard format)
C <sub>1</sub>	1000000	Normal (1000000,200000, truncate (0,5000000))
C <sub>2</sub>	100000	Normal (100000,10000, truncate (0,1000000))
C <sub>3</sub>	10000	Triang (0,10000,20000)
C <sub>4</sub>	1000	Triang (0,1000,2000)

#### 4. Calculation of the probability of top event in fault tree

With the help of figures 57 and A1 the probabilities of the intermediate events and finally top event can be easily derived and calculated. The equations for solving the "rectangle" probabilities are:

$$\begin{aligned}
 P_{12} &= 1 - [(1-P_3)(1-P_4)] \\
 P_{13} &= 1 - [(1-P_6)(1-P_7)(1-P_8)(1-P_9)] \\
 P_{14} &= P_{12} P_5 \\
 P_{15} &= P_5 P_{13} \\
 P_{16} &= 1 - [(1-P_1)(1-P_2)] \\
 P_{17} &= 1 - [(1-P_{14})(1-P_{15})] \\
 P_{TOP} &= 1 - [(1-P_{16})(1-P_{17})(1-P_{10})(1-P_{11})]
 \end{aligned}$$

Now the event frequencies can be calculated by inserting the starting values (either deterministic or distributions) from table A1 into the equations above. With deterministic starting values the frequencies for intermediate events and top event are obtained immediately. The result is:

$$\begin{aligned}
 P_{12} &= 0.0892 \\
 P_{13} &= 0.020846 \\
 P_{14} &= 0.0892 \\
 P_{15} &= 0.020846 \\
 P_{16} &= 0 \\
 P_{17} &= 0.108187 \\
 P_{TOP} &= 0.10997
 \end{aligned}$$

When distributions and simulation is used, the result is a distribution also. With this example 10000 simulations were used. The resulting distribution for top event is presented in figure A3. As can be seen in figure, the mean of the distribution is close to the deterministic value, which is logical. However, with the distribution result the confidence interval can be easily seen. Also the sensitivity analysis is performed automatically, as can be seen in figure A4. The two biggest contributors to the top event are the factors P3 and P4, which can be identified in figure A1.

In the following figures (which are screenshots of the @RISK programme) there appear letter-number codes preceded by slash on the titles and sides of the screenshots, for example in figure A1 there appears a code /E23 in the title. These codes refer to the Excel worksheet cells used in this quantification example. This Excel worksheet is presented in figure A9.

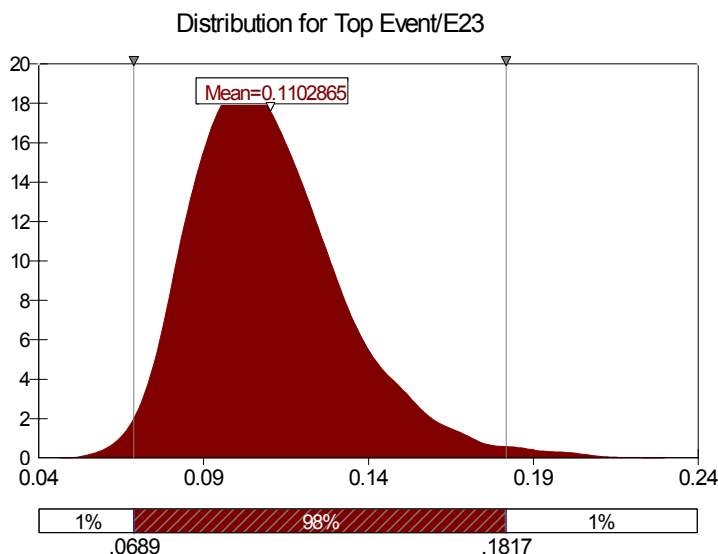

Figure A3. Simulated distribution for top event frequency.

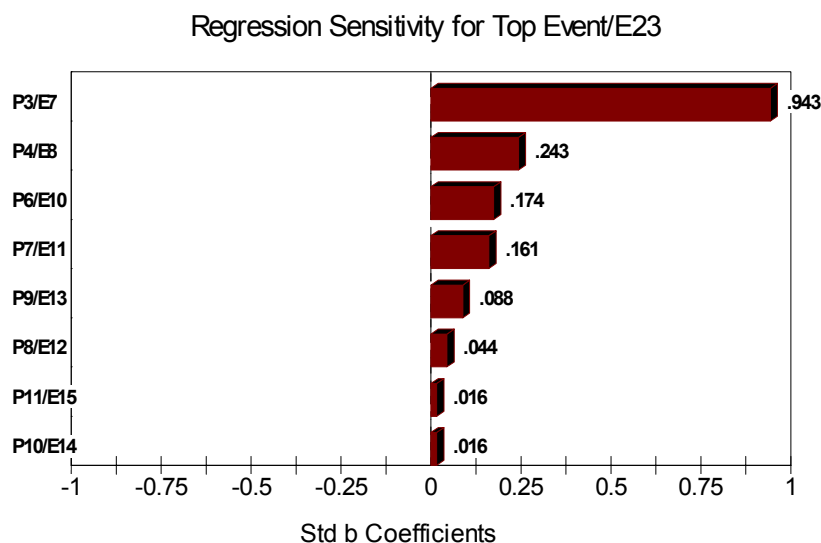

Figure A4. Sensitivity analysis for top event.

## 5. Calculation of the expected costs in case of falling

The different possible consequences of falling in safety category are presented in figure A2, and in tables A2 and A3 the numeric values have been estimated. Now the expected costs in case of falling can be easily calculated:

$$C_{\text{falling}} = E_{11}C_1 + E_{12}[E_{22}C_4 + E_{21}(E_{31}C_2 + E_{32}C_3)]$$

With deterministic values the result is obtained immediately by inserting the starting values into the equation above. The result is:

$$C_{\text{falling}} = 122770 \text{ €}$$

When probabilistic values and simulation is used, the result differs a lot from the deterministic solution. This is due to difference in logics: while in deterministic model mean (or expected) values are used, simulation randomly chooses different scenarios, and repeats the procedure as long as wanted. As there is discontinuity in consequence values of different outcomes, more than one peak is expected in the resulting distribution. The distribution of consequence costs after 10000 simulations is presented in figure A5, and in figure A6 the result of sensitivity analysis is shown. The event E<sub>1</sub> has the biggest contribution to the consequences.

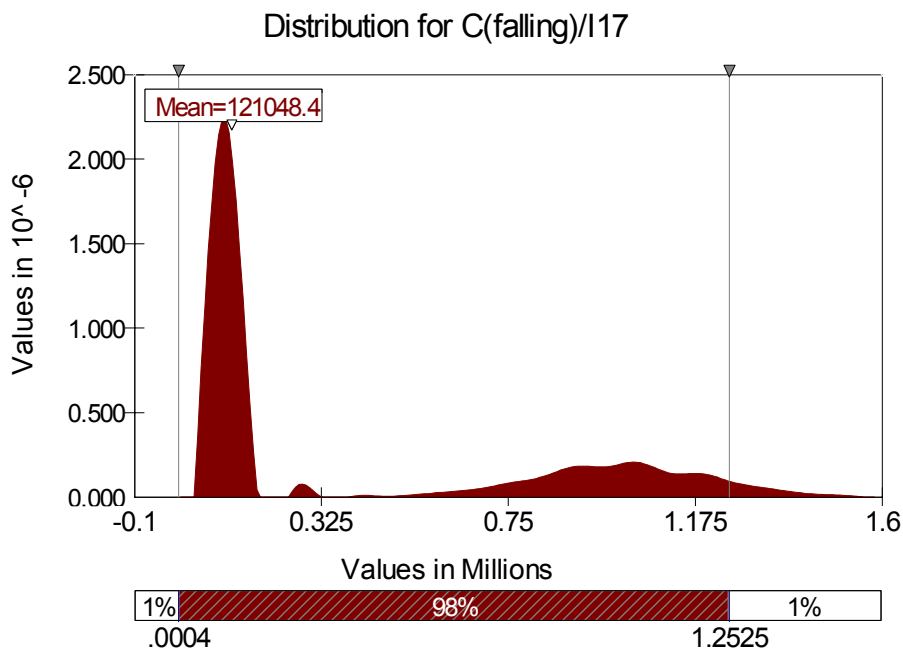

Figure A5. Distribution for consequence costs in case of falling.

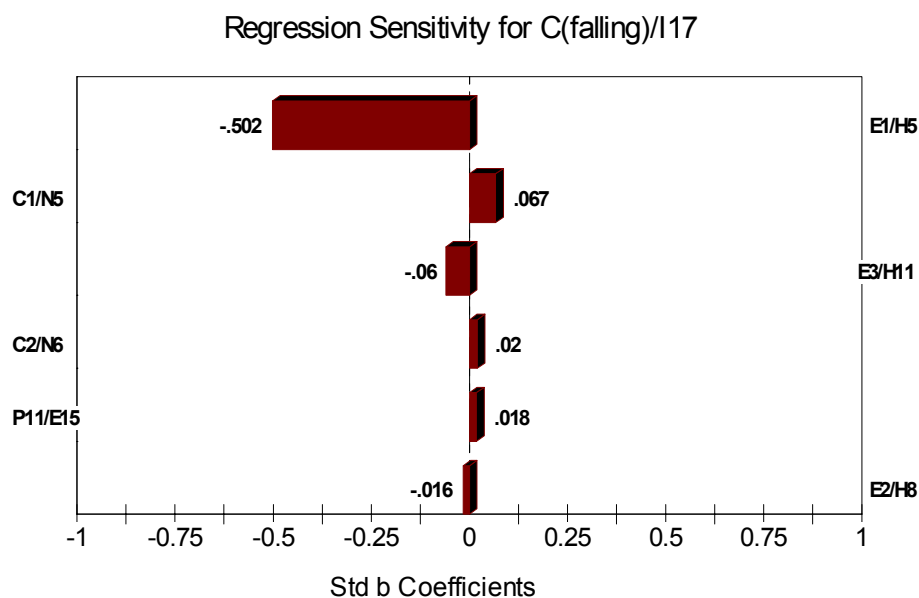

Figure A6. Sensitivity analysis for consequence costs in case of falling.

## 6. Combining of fault tree and event tree calculations to obtain the value for risk

When both the probability of top event and the expected costs have been calculated, the value of risk is obtained simply as a product of those two factors. In case of deterministic values the result is:

$$\text{Risk} = P_{\text{TOP}} * C_{\text{falling}} = 0.10997/\text{year} * 122770 \text{ €} = 13500.98 \text{ €/year}$$

When using simulation for calculation, the risk is (like in the deterministic case) product of the top event probability and consequence cost. But instead of calculating value for the expected costs of falling, the consequence value is simulated on each simulation round and that obtained consequence value is multiplied with the top event value of the same simulation round. The resulting risk value is stored, and after certain number of simulations a distribution for risk can be drawn. The distribution in figure A7 is obtained after 10000 simulations. The sensitivity analysis is presented in figure A8.

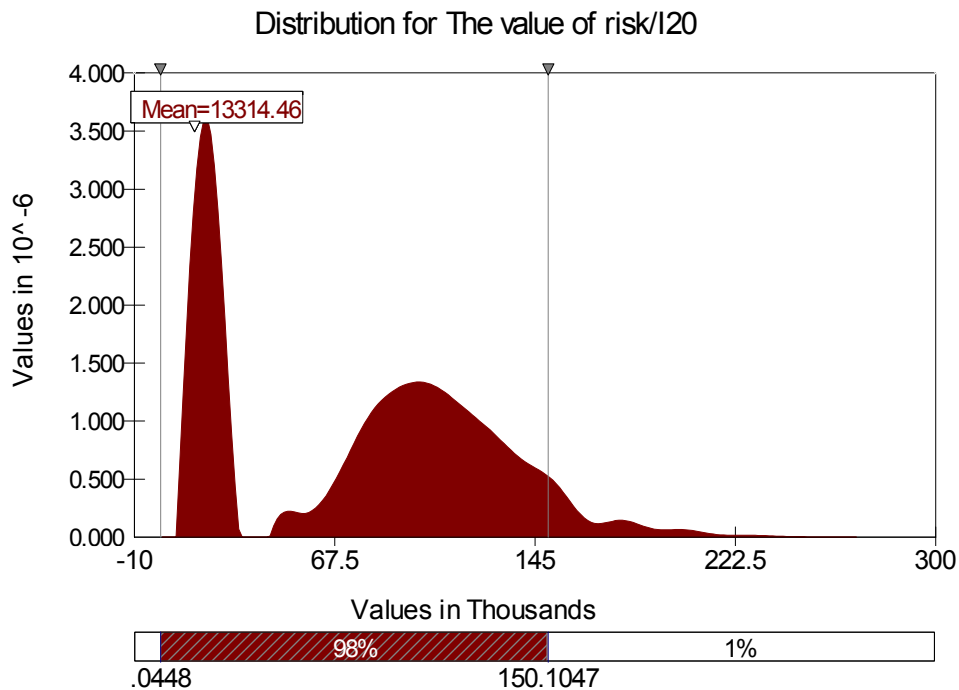

Figure A7. Distribution for the risk.

As can be seen, the simulation results reveal the advantage of using distributions. While the deterministic calculation gives only one value for risk (a mean), simulation presents in addition the whole range of possible values for risk. By changing the confidence interval limits the chance for high consequences can be examined. Most of the simulation programmes perform also the sensitivity analysis automatically.

The example above was for illustrative purpose only, to show the quantified use of fault tree and event tree. However, the presented quantification possibility does not help an end user who does not have numerical source data or expertise to be inserted in the fault and event tree. In those cases the analyses are performed only qualitatively.

Regression Sensitivity for The value of risk/I20

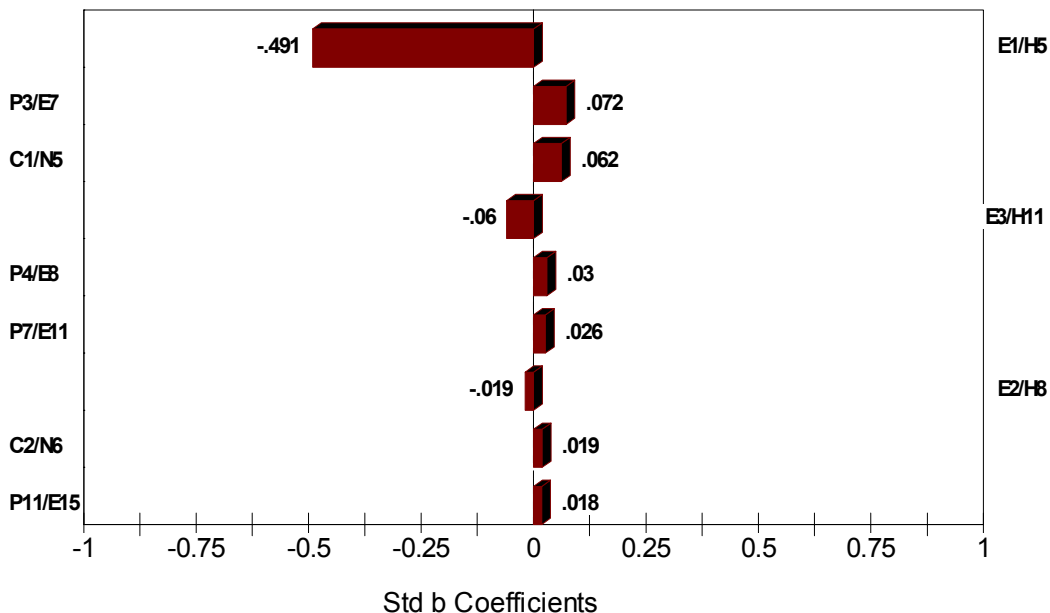

Figure A8. Sensitivity analysis for the risk.

	A	B	C	D	E	F	G	H	I	J	K	L	M	N	
1	<b>Deterministic risk</b>			<b>Simulated risk</b> (Input distributions in light shaded cells, output distributions in dark shaded cells)											
2															
3	FTA deterministic			FTA simulation				ETA simulation		limit value	(Table A2)		ETA consequences		
4	(Table A1)			(Table A1)							E11	E12	(Table A3)		
5	P1	0		P1	0		E1	0.5	0.9	0	1	C1	1000000		
6	P2	0		P2	0							C2	100000		
7	P3	0.08		P3	0.08026		E2	0.5	0.9	1	0	C3	10000		
8	P4	0.01		P4	0.010061							C4	1000		
9	P5	1		P5	1		E3	0.5	0.8	0	1				
10	P6	0.008		P6	0.008042										
11	P7	0.007		P7	0.006974										
12	P8	0.002		P8	0.002										
13	P9	0.004		P9	0.004										
14	P10	0.001		P10	0.001										
15	P11	0.001		P11	0.001										
16	P12	0.0892		P12	0.089514										
17	P13	0.020846		P13	0.020862										
18	P14	0.0892		P14	0.089514										
19	P15	0.020846		P15	0.020862										
20	P16	0		P16	0										
21	P17	0.108187		P17	0.108509										
22	PTOP	0.10997		PTOP	0.110291										
23															
24															
25	ETA deterministic (Tables A2 and A3)			Expected cost (deterministic)											
26	probability			cons.value				in case of falling:							
27	E11	0.1	C1	1000000	<u>122770 €</u>										
28	E12	0.9	C2	100000											
29	E21	0.9	C3	10000											
30	E22	0.1	C4	1000	<u>13501 €/year</u>										
31	E31	0.2													
32	E32	0.8													
33															

Figure A9. The Excel worksheet used for the quantification procedure. Note: The comparison of deterministic and simulated risk cannot be made by comparing directly the numbers in cells F27 and I17 for the consequence costs, or the cells F30 and I20 for the value of risk. The comparable simulation results are presented in figures A5 and A7.