

# Wideband Adaptive Isolator for UHF RFID Reader

Pekka Pursula, Ilkka Marttila, and Kaj Nummila

VTT Technical Research Centre of Finland, Tietotie 3, 02150 Espoo, Finland, email pekka.pursula@vtt.fi.

*Abstract:* This paper introduces a wideband adaptive isolator for UHF RFID reader with a minimum component count. The operation of the device is based on a reflection from a variable load, which is connected to a port of a hybrid coupler. The other ports are connected to the RX, TX and Antenna ports of the reader. The isolator provides an isolation of 50 dB from TX to RX at 800 MHz - 1 GHz band, covering all the UHF RFID bands worldwide. The adaptive system ensures high isolation up to an antenna return loss of 6 dB, or reflection coefficient 0.5. The measured loss in the TX-to-Antenna and Antenna-to-RX paths is 4 dB.

*Introduction:* A known problem in Radio Frequency Identification (RFID) at UHF band is the signal coupling from transmitter (TX) to receiver (RX) port. The transmit power of up to  $4 W_{\text{eirp}}$  couples to the receiver, deteriorating the sensitivity of the reader by saturating the receiver front end [1] and coupling transmitter noise to the receiver [2]. The problem is becoming more and more important, because the newly introduced semi passive transponders provide longer read ranges, and hence fainter backscattered signals to the reader. The problem is known from FMCW radar [3] and later analysed also in UHF RFID [1].

In the case of UHF RFID, the problem has been addressed in [4-5] by directional coupler design, providing good isolation at a narrow band. But as static devices, these cannot adapt to any change of the coupling. Any variation of the near environment of the antenna affects the input impedance of the antenna. Hence the coupling is effectively defined by the return loss, or reflection coefficient, of the antenna. In [2-3, 6] active isolator circuits are described. The circuits are based on the addition of an antiphase signal. The compensation line has quadrature attenuator and couplers in TX and RX. The adaptive solution provides wider band and possibility to eliminate the changes in the environmental reflection, but with the expense of complexity. A possibility to reduce the system complexity is to use a hybrid transformer and realise an impedance measurement bridge, as in [7].

But, an isolator based on reflection, rather than addition, requires fewer components, and provides isolation at even wider band, because the signal path lengths can be minimised. The reflection-based isolator described in this paper requires only a hybrid coupler, and a variable quadrature load. The system is less complex, encompassing all the static phase shift crucial to adapter stability within the hybrid component. This minimization of the signal path difference maximises the isolator bandwidth.

The system is analyzed in detail in the next section, after which measurement results are presented and the paper concluded.

*Theory:* The isolator consists of a hybrid and a variable load. The block diagram of the isolator is presented in Fig 1. The analysis and operation principle hold for a 90 or 180 degree hybrid, as well as for a directional coupler.

In this paper, a 90 degree hybrid with the ideal scattering parameters

$$[s] = \frac{1}{\sqrt{2}} \begin{bmatrix} 0 & j & -1 & 0 \\ j & 0 & 0 & -1 \\ -1 & 0 & 0 & j \\ 0 & -1 & j & 0 \end{bmatrix} \quad (1)$$

is used. The load connected to the port  $n$  of the hybrid have the external reflection coefficients  $\Gamma_n$ . Assuming matched TX and RX ports, i.e.  $\Gamma_1 = 0$  and  $\Gamma_4 = 0$ , the overall S-parameters for ports 1 and 4 take the form

$$\begin{bmatrix} S_{11} & S_{14} \\ S_{41} & S_{44} \end{bmatrix} = \begin{bmatrix} (-\Gamma_2 + \Gamma_3)/2 & -j(\Gamma_2 + \Gamma_3)/2 \\ -j(\Gamma_2 + \Gamma_3)/2 & (\Gamma_2 - \Gamma_3)/2 \end{bmatrix}. \quad (2)$$

The isolation criterion can be seen from Eq. (2). Minimising the coupling between ports 4 and 1, we require  $S_{41} = 0$ , i.e.  $\Gamma_3 = -\Gamma_2$ . Isolation can be achieved by adjusting the variable load reflection coefficient to the opposite of the reflection at the antenna port. The drawback is power loss, because some power has to be coupled to the variable load. In the case of the hybrid, the power loss is ideally 3 dB. A directional coupler would deliver lower TX power loss, but higher RX power loss.

The variable load can be easily realised as a parallel resonator with a PIN-diode as the variable resistor and a varactor diode as the variable capacitor.

*Measurement results:* The realised circuit was measured with a matched load at the antenna port to experimentally show the wideband characteristics of the device. The

maximum isolation achieved by tuning the load is presented at four different frequencies in Fig 2. Over 50 dB of isolation is achieved over a tuning bandwidth of 200 MHz, from 800 to 1000 MHz. The isolation bandwidth is approximately 5 MHz at an isolation of 40 dB, which is more than required for the UHF RFID, where data bandwidths are less than 1 MHz. The Fig 2 also presents TX and RX losses, i.e.  $S_{21}$  and  $S_{42}$  respectively, when the device is tuned for maximum isolation at 867 MHz.

The tuning range, i.e. the antenna port loads  $\Gamma_2$  that can be isolated, of the device was measured by connecting a known (almost matched) load to the antenna port. The variable load was adjusted to the extrema values of the tuner impedance. Using the isolation criterion, the extrema of the antenna impedances that can be isolated can be calculated from S-parameters  $S_{41}$ ,  $S_{11}$  and  $S_{44}$ ,

$$\Gamma_2 = -\Gamma_3 = 2jS_{41} + \frac{1}{2}(S_{44}^0 - S_{11}^0), \quad (3)$$

where the superscript 0 refers to S-parameters that are measured at isolation, i.e., when  $S_{41} = 0$ .

The Fig 3. presents the area of the reflection coefficients of the antenna that can be isolated at 867 MHz in polar form. The simulated values are calculated using the parallel resonator model introduced in Fig 1. The simulated values support the measured values. All antenna loads with  $\Gamma_2 < 0.5$  or antenna return loss up to 6 dB can be isolated.

*Conclusion:* This paper presented the theory and measurement results of a reflection-based active isolator for UHF RFID reader. The device consists of a hybrid coupler connected to reader RX, TX and Antenna ports, as well as a variable quadrature load. The isolator provides an isolation of 50 dB from TX to RX. The adaptive system delivers the

isolation at 800 MHz – 1 GHz band, covering all the UHF RFID bands worldwide, up to an antenna return loss of 6 dB, or reflection coefficient 0.5. The isolator has the measured loss of 4 dB in the TX-to-Antenna and Antenna-to-RX paths.

*Acknowledgments:* This research has been financially supported by the European Union under Indisputable Key project.

## References

- 1 Curty J.-P., Declercq M., Dehollain C., and Joehl N.: "Design and Optimization of Passive UHF RFID Systems", (Springer, 2007).
- 2 Pursula P., Kiviranta M., and Seppä H.: "UHF RFID Reader with Reflected Power Canceller", *IEEE Microw. Wireless Compon. Lett.*, 2009, 19, (1), pp. 48-50.
- 3 Stove A. G.: "Linear FMCW radar techniques", *IEE Proceedings-F*, 1992, 139, (5), pp. 343-350.
- 4 Wei F., Shi X. W., Huang Q. L., Chen D. Z., and Wang X. H.: "A New Directional Coupler for UHF RFID Reader", *Microw Opt Tech Lett*, 2008, 50, (7), pp. 1973-1975.
- 5 Kim W.-K., Na W., Yu J.-W., and Lee M.-Q.: "A High Isolated Coupled-Line Passive Circulator for UHF RFID Reader", *Microw Opt Tech Lett*, 2008, 50, (10), pp. 2597-2600.

6 Jung J.-W., Roh H.-H., Kwak H.-G., Jeong M. S., and Park J.-S.: "Adaptive TRX Isolation Scheme by Using TX Leakage Canceller at Variable Frequency", *Microw Opt Tech Lett*, 2008, 50, (8), pp. 2043-2045.

7 Pursula P. and Seppä H.: "Hybrid Transformer Based Adaptive RF Front End for UHF RFID Mobile Phone Readers", *IEEE Int. Conf. on RFID*, April 2008, Las Vegas, pp. 150-155.

## Captions

Fig. 1 Block diagram of the isolator circuit.

Fig. 2 Measured S-parameters of the isolator circuit: The isolation ( $S_{41}$ ) with different tuner circuit values. Transmission loss ( $S_{21}$ ) and reception loss ( $S_{42}$ ) are presented when isolation is optimised at 867 MHz.

Fig 3. Measured and simulated values of the antenna reflection coefficient that can be isolated at 867 MHz.

Figure 1

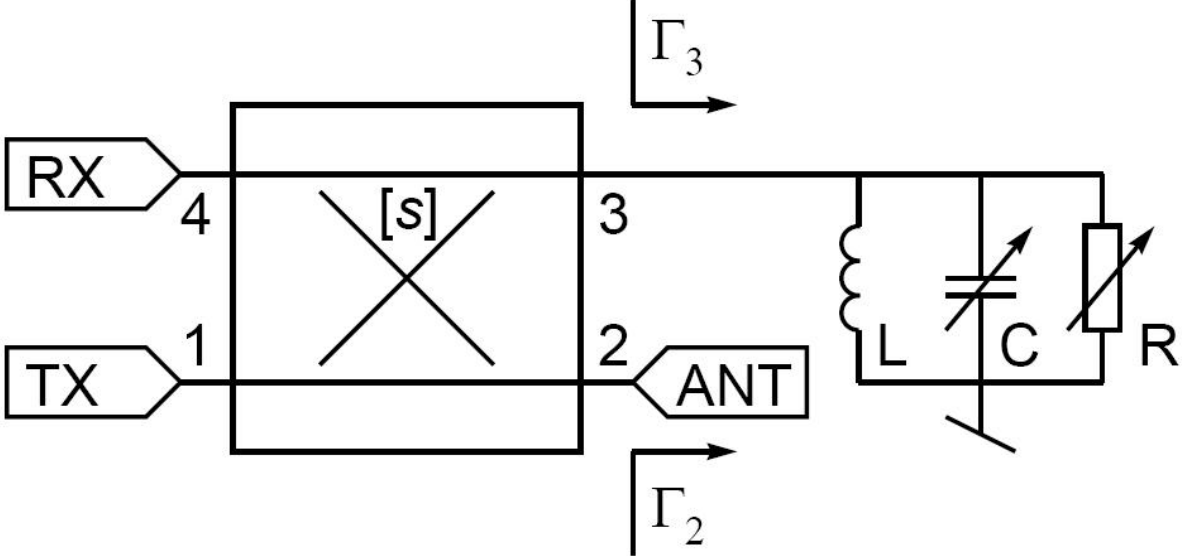



Figure 2

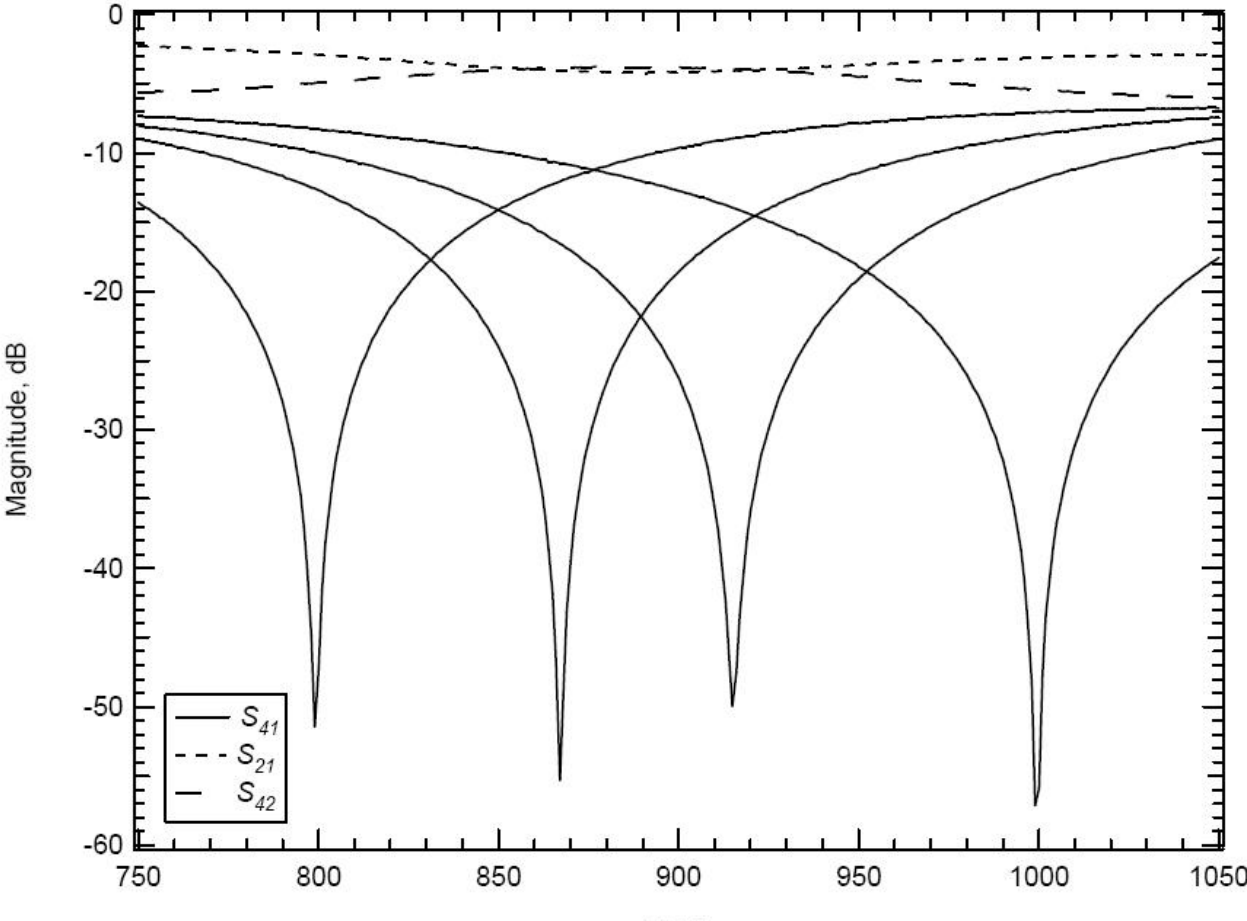

Figure 3

