

# UHF RFID Reader With Reflected Power Canceller

Pekka Pursula, Mikko Kiviranta, and Heikki Seppä

**Abstract**—Reflected power imposes severe linearity problems to the receiver in radio frequency identification (RFID) readers. In this letter, the design and realization of a ultra high frequency RFID reader with a reflected power canceller circuit based on quadrature feedback are presented. Theory and measurements of the signal and noise in the receiver are presented as a function of incident carrier power. The receiver sensitivity is even better than without the canceller with high incident carrier power: A noise spectral density at the data band is  $-140$  dBm/Hz at  $+12$  dBm incident carrier power. At the same time, input compression point of  $+15$  dBm is achieved. The dynamic range of the receiver is improved by 10 dB.

**Index Terms**—Carrier suppression, high-Q active filter, reflection canceller, radio frequency identification (RFID), ultra high frequency (UHF).

## I. INTRODUCTION

A known problem in a ultra high frequency radio frequency identification (UHF RFID) reader is carrier power leakage from the transmitter to the receiver [1]. This creates high linearity requirements for the receiver. Similar problems have been encountered in frequency modulated continuous wave (FMCW) radars, where several solutions have been documented: a reflected power canceller (RPC) circuit with PIN diodes [2], [3] and a balanced topology front end [4].

A similar approach can be used in UHF RFID. The idea has been described by the authors [5] and others [6]. However, these patents include several possible RPC circuits without presenting thorough analysis of the circuits.

In this letter, a UHF RFID reader with a RPC circuit is analysed theoretically, and measurement results are presented, clearly showing the benefit of the chosen topology, especially the usage of PIN diodes. The authors have also presented another approach to achieve these goals in RFID readers [7].

In the next section, the signal and noise in the electronics is analysed. Then measurement results from a prototype are presented, and the letter is concluded.

## II. THEORY

The quadrature, or Cartesian, feedback is known from many applications, e.g., PA linearization [8] and FMCW radar [3]. The principle is most concisely expressed for complex-valued signals. Referring to Fig. 1, the received signal has the complex

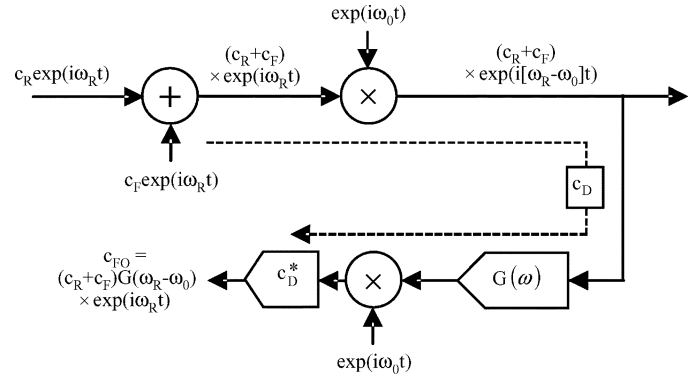

Fig. 1. Signal flow of the quadrature feedback in the case of complex-valued signals.

amplitude  $c_R$ . Complex amplitude  $c_F$  is assumed for the compensating feedback signal. The open-loop feedback signal  $c_{FO}$  can be calculated as done in Fig. 1 and equated with assumed feedback signal  $c_F$ . Solving  $c_F$  gives the amplitude of the signal fed to the downmixer, when the feedback loop is closed

$$c_R + c_F = c_R \frac{1}{1 - c_D^* c_D G(\omega_R - \omega_0)}. \quad (1)$$

Here,  $c_D = \exp(i\theta)$  is the phase shift due to the delay and parasitics in the signal path, compensated by the  $c_D^*$  term designed into the circuit. When a single-pole low-pass loop filter  $G(\omega) = -G_0/(1 + i\omega/\omega_C)$  is chosen and perfect delay compensation  $c_D^* c_D = 1$  is assumed, the downmixer signal becomes

$$c_R + c_F = c_R \left( 1 + G_0 \frac{\omega_C}{\omega_C + i(\omega_R - \omega_0)} \right)^{-1} \quad (2)$$

which is equivalent to applying a notch filter with bandwidth  $\omega_C$  and center frequency  $\omega_0$  to the received signal. Because the  $\omega_0$  is determined by the local oscillator, which is independent of the  $\omega_C$ -determining loop filter, tremendously effective  $Q$ -values can be obtained. In the context of RFID such a steep notch can be used to filter away the carrier power, and still pass the tag-backscattered side bands to the downmixer. In this manner the downmixer and the low noise amplifier (LNA) associated with it can be kept from saturating.

Without the quadrature feedback, the dynamic range of a RFID receiver is typically determined as the difference between the noise floor and high-power compression point of the downmixer or LNA. In the compensator-equipped circuit in Fig. 1, the dynamic range of the upmixer in the feedback path becomes the bottleneck, and nothing is gained if the upmixer is fabricated using the same technology as the downmixer, because the two then tend to have the same dynamic range limitation. Fortunately PIN-diodes offer a very large dynamic range and can be used as upmixers. Their noise floor is effectively thermally limited and power handling capacity exceeds

Manuscript received June 19, 2008; revised September 08, 2008. First published December 22, 2008; current version published January 08, 2009. The work was supported in part by the European Union through FP6 and Tekes, and the Finnish Funding Agency for Technology and Innovation.

The authors are with VTT, Technical Research Centre of Finland, Espoo FIN 02150, Finland (e-mail: pekka.pursula@vtt.fi).

Color versions of one or more of the figures in this letter are available online at <http://ieeexplore.ieee.org>.

Digital Object Identifier 10.1109/LMWC.2008.2008607

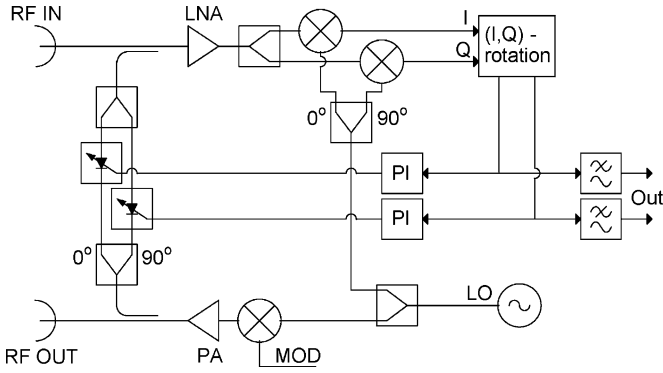

Fig. 2. Block diagram of the reader.

+20 dBm. Because their reaction speed to the control current is typically limited to below 100 kHz, they cannot be used directly as downmixers.

The proposed circuit for two real-valued quadrature signals rather than one complex-valued signal is presented in Fig. 2. The feedback includes two parallel analog loops, that are orthogonalized at the base band. The electronics can also be implemented with a single antenna and a circulator.

The sensitivity of the receiver is described by the input referred noise power spectral density  $S$ . The LNA and downmixer noise contributions are lumped into  $S_{RX}$ . The noise power radiated by the transmitter is a constant fraction  $\alpha_O$  of the radiated carrier power, so that the noise contribution at the receiver due to the reflection from the environment  $S_{TX} = \alpha_O P_{in}$  can be expressed in terms of the received carrier power  $P_{in}$ . When the RPC loop is closed, the baseband circuitry adds a constant noise term  $S_F$  caused by base band amplifiers and a power-dependent noise term  $\alpha_F P_{in}$  caused by PIN diode shot noise and downmixer-to-upmixer leakage at data band. The input referred noise can then be expressed as

$$S = S_{RX} + \alpha_O P_{in} \quad (3)$$

when the RPC is inactive, and as

$$S = S_{RX} + S_F + \frac{\alpha_O P_{in}}{G_0} + \alpha_F P_{in} \quad (4)$$

when the RPC is functioning. The RPC suppresses the  $S_{TX}$  by carrier frequency loop gain  $G_0$ , because the compensating and received signals are derived from the same source, so that noise of the compensating signal is correlated with  $S_{TX}$ . In the case  $G_0 \gg 1$ , the ratio  $\alpha_F/\alpha_O$  determines whether activation of the RPC circuit increases or decreases the noise power at the data band, given a received carrier power level  $P_{in}$ .

The feedback limits the dynamic range: The LNA stays linear as far as the incident carrier power is less than the maximum output power of the feedback path, and the noise level is determined by the feedback noises  $S_F$  and  $\alpha_F$ . Especially, if diode ring mixer is used as the feedback mixer, the noise floor can be thermally limited, but their maximum output power is limited to around 0 dBm. Adding an RF amplifier after the mixer improves output power by the amplifier gain, but also raises  $S_F$  by the same gain. Thus dynamic range cannot be improved with such a device. The PIN diode attenuator provides both low noise and high output power without an additional amplifier, and dynamic range is improved.

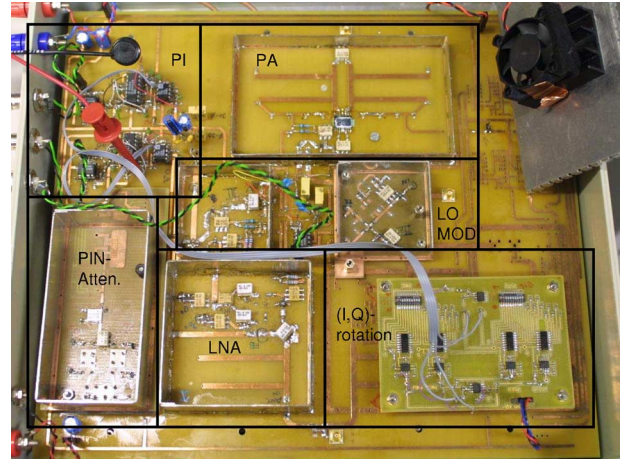

Fig. 3. Photograph of the 865 MHz electronics.

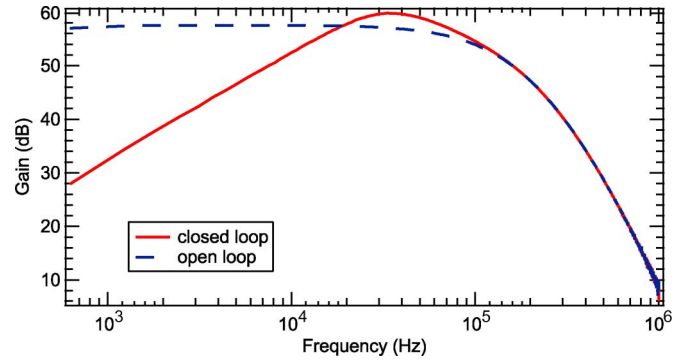

Fig. 4. Measured gain from RF input single side band to base band output as a function of offset frequency from the carrier.

### III. PROTOTYPE AND MEASUREMENTS

Two prototype systems have been realized; one at the 865 MHz band for the European UHF RFID, and another for the 2.4 GHz ISM band. The 2.4 GHz version was built using the Maxim MAX2701/2721 chipset and the I/Q compensation control implemented digitally in an Altera Cyclone II FPGA.

The measurement results from the 865 MHz reader are presented here. The electronics was made of discrete components, and all the base band components used analog electronics: The (I,Q)—rotation circuit was realized using multiplying D/A—converters. Loop filters are analog PI controllers. PIN-diode attenuators similar to [9] were used as upmixers. A photograph of the prototype is presented in Fig. 3. The maximum RF power of the transmitter is 0.5 W.

The system was measured with a FFT analyzer. The side band signal gain was measured to see the carrier suppression. The stop band near the carrier is seen from Fig. 4. The upper cutoff is realized by a low pass filter in the base band output. The input referred noise of the receiver is presented in Fig. 5. The measurements show that the reflected power canceller (RPC) presented here suppresses the carrier, yet leaves data band at 10–100 kHz intact. The overshoot in the closed loop gain is due to insufficient phase margin in the feedback loop.

The input compression point and the noise spectral density of the receiver as a function of incident carrier power was measured by routing the transmitter output through an attenuator to

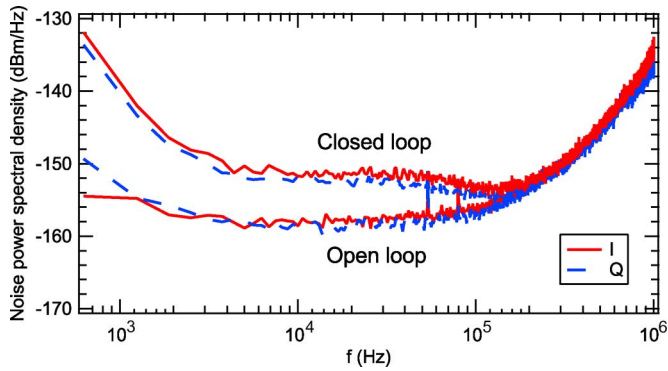

Fig. 5. Measured input referred noise spectral density as a function of offset frequency from the carrier.

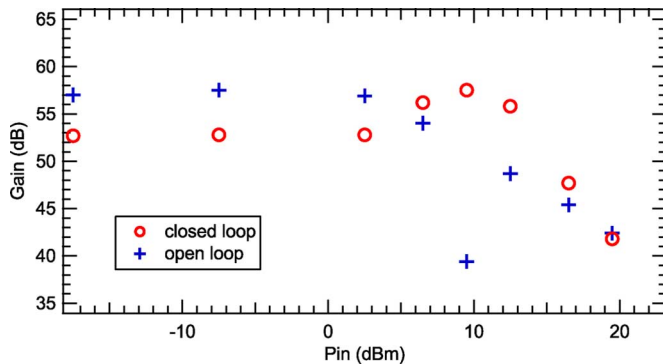

Fig. 6. Measured gain from RF input single side band to base band output at data band (offset 20 kHz) as a function of incident carrier power. Signal power is kept constant throughout the measurement, and only carrier power is altered.

the receiver. A mixer was connected parallel to the attenuator to add a CW side band signal to the data band with a constant amplitude to simulate the transponder backscattering. The incident carrier power was swept but the power of the CW signal at data band was unaltered. The gain from the RF single side band to base band output as a function of the incident carrier power is presented in Fig. 6. The figure shows that the reflected power canceller raises the compression point of the receiver by about 10 dB. The limiting factor is the power driving capability of the RPC. The overshoot in the closed loop signal level is due to a change in the controller loop gain, which is power-dependent due to the power-law response of the PIN diode to the control current.

The input referred noise spectral density at the data band as a function of received carrier power is presented in Fig. 7, as well as a fit according to (3) and (4). The feedback increases noise of the receiver by about 5 dB at low incident carrier power. At high incident carrier power the feedback reduces the noise by about 3 dB. Better noise reduction is to be expected, if the feedback loop gain cutoff is moved nearer to the carrier, because this diminishes leakage from the downmixer. The achieved noise spectral density of  $-140$  dBm/Hz at  $+12$  dBm incident carrier power converts to total sensitivity of about  $-90$  dBm with 100 kHz bandwidth, but comparison to commercial products is not straightforward. For example, in [10] a reader sensitivity of  $-80$  dBm is promised, but no comment on incident carrier power is given.

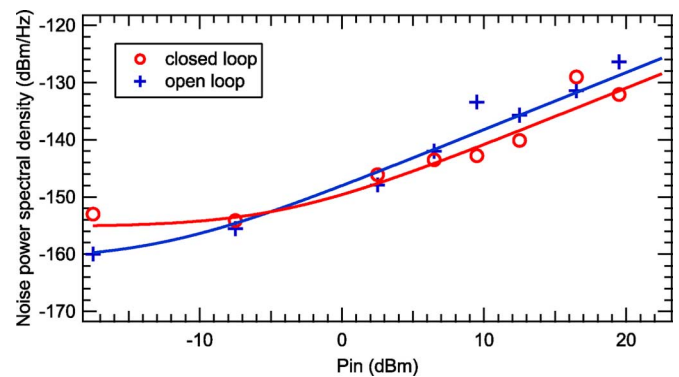

Fig. 7. Measured input referred noise spectral density at data band (offset 50 kHz) as a function of received carrier power.

#### IV. CONCLUSION

We have suggested a reflected power canceller (RPC) based on quadrature feedback for UHF RFID reader. The RPC suppresses the incident carrier at the receiver input. Hence the carrier cannot saturate the receiver, and high sensitivity of the receiver can be preserved even with high reflected carrier power.

The measurements show that the reflected power canceller presented here suppresses the carrier, yet leaves the data band intact. The noise performance of the receiver is not compromised by the feedback: In fact, the noise spectral density of the receiver is even less than without the RPC with high incident carrier power, because of the noise compensation behavior of the system. The input compression point of the receiver is about  $+15$  dBm. The receiver sensitivity of  $-140$  dBm/Hz at  $+12$  dBm incident carrier power is achieved. Overall, the reader dynamic range is increased by 10 dB.

#### REFERENCES

- [1] J.-P. Curty, M. Declercq, C. Dehollain, and N. Joehl, *Design and Optimization of Passive UHF RFID Systems*. New York: Springer, 2007.
- [2] P. D. L. Beasley, A. G. Stove, B. J. Reits, and B.-O. As, "Solving the problems of a single antenna frequency modulated CW radar," in *Proc. IEEE Radar Conf.*, 1990, pp. 391–395.
- [3] A. G. Stove, "Linear FMCW radar techniques," *Proc. Inst. Elect. Eng. F*, vol. 139, no. 5, pp. 343–350, Oct. 1992.
- [4] J.-G. Kim, S. Ko, S. Jeon, J.-W. Park, and S. Hong, "Balanced topology to cancel Tx leakage in CW radar," *IEEE Microw. Wireless Compon. Lett.*, vol. 14, no. 9, pp. 443–445, Sep. 2004.
- [5] H. Seppä, T. Varpula, P. Pursula, and M. Kiviranta, "RFID Reading Apparatus and Method," International patent WO/2007/006840, Jan. 2007.
- [6] A. Safarian, A. Sharneli, A. Rofougaran, and M. Rofougaran, "Integrated Blocker Filtering RF Front End," U.S. patent US/2008/0009258, Jan. 2008.
- [7] P. Pursula and H. Seppä, "Hybrid transformer based adaptive RF front end for UHF RFID mobile phone readers," in *Proc. IEEE Int. Conf. RFID*, Las Vegas, NV, Apr. 16–17, 2008, pp. 150–155.
- [8] J. L. Dawson and T. H. Lee, "Cartesian feedback for RF power amplifier linearization," in *Proc. Amer. Control Conf.*, 2004, vol. 1, pp. 361–366.
- [9] W.-T. Kang, I.-S. Chang, and M.-S. Kang, "Reflection-type low-phase-shift attenuator," *IEEE Trans. Microw. Theory Tech.*, vol. 46, no. 7, pp. 1019–1021, Jul. 1998.
- [10] Elektrobit Company, "EB RFID Reader EB UR1000-ETSI Datasheet," May 2008 [Online]. Available: [www.elektrobit.com/file.php?110](http://www.elektrobit.com/file.php?110)