

Title UHF RFID Based Tracking of Logs in the
Forest Industry
Author(s) Häkli, Janne; Jaakkola, Kaarle; Pursula,
Pekka; Huusko, Mika; Nummila, Kaj
Citation 2010 IEEE International Conference on RFID
(IEEE RFID 2010). Orlando, FL, USA, 14-16
April 2010, pp. 245-251
Date 2010
URL <http://dx.doi.org/10.1109/RFID.2010.5467272>
Rights Copyright © [2010] IEEE.
Reprinted from 2010 IEEE International
Conference on RFID (IEEE RFID 2010).
Orlando, FL, USA, 14 - 16 April 2010.
ISBN 978-1-4244-5742-7.

This material is posted here with permission of the IEEE. Such permission of the IEEE does not in any way imply IEEE endorsement of any of VTT Technical Research Centre of Finland's products or services. Internal or personal use of this material is permitted. However, permission to reprint/republish this material for advertising or promotional purposes or for creating new collective works for resale or redistribution must be obtained from the IEEE by writing to pubspermissions@ieee.org.

By choosing to view this document, you agree to all provisions of the copyright laws protecting it.

<p>VTT http://www.vtt.fi P.O. box 1000 FI-02044 VTT Finland</p>	<p>By using VTT Digital Open Access Repository you are bound by the following Terms & Conditions.</p> <p>I have read and I understand the following statement:</p> <p>This document is protected by copyright and other intellectual property rights, and duplication or sale of all or part of any of this document is not permitted, except duplication for research use or educational purposes in electronic or print form. You must obtain permission for any other use. Electronic or print copies may not be offered for sale.</p>
---	---

UHF RFID Based Tracking of Logs in the Forest Industry

Janne Häkli, *Member, IEEE*, Kaarle Jaakkola, Pekka Pursula, Miika Huusko, and Kaj Nummila

Sensors and Wireless Devices
VTT Technical Research Centre of Finland
Espoo, Finland
firstname.surname@vtt.fi

Abstract— This paper describes a prototype of a UHF RFID based log marking and tracking system developed for the challenging four-season outdoor conditions in Scandinavia. The RFID system comprises of novel pulping compatible EPC Class 1 Generation 2 transponders, and of robust readers with novel performance boosting features. A wedge-shaped transponder is inserted into the log end with a special tool so that it is protected and held firmly in place by wood during the transportation and processing of timber. A robust EPC-compliant RFID reader featuring an adaptive RF front end was developed for use in a harvesting machine. Readability tests at saw mills with test logs using specially adapted commercial UHF readers show nearly a 100 % readability for the transponders inside fresh moist logs.

Keywords—UHF RFID; Forest industry; log marking; timber tracking; wood traceability

I. INTRODUCTION

In the forest industry wood is treated mostly as a bulk raw material and it is graded at the final stages of the production. Significant savings can be achieved if the right kind of timber, is used for the end product that it is best suited for, so that the unnecessary down-grading is minimized and the yield of the desired product is maximized. Better overall control of the information and material flows helps to optimize the production efficiency in the forestry and to minimize the environmental burden. The key for implementing this control is the identification and tracking of the timber items, i.e. tree trunks and logs. Automated log identification in the wood supply chain helps to eliminate the need for multiple measurements and repeated inventories of timber stocks that are currently common. Traceability of timber also provides means to verify the chain of custody and the origin of the timber, and thus helps to prevent illegal loggings and to promote sustainable forestry practices.

Several marking technologies have been used or considered for tracking of timber. They include conventional and special paint markings, chisel labels, branding hammers, attached plastic or paper tags, barcode tags, smart cards, chemical, genetic or biological fingerprinting, and RFID [1]. RFID technology has a number of advantages over the other marking methods in the forestry: line of sight is not needed, the reading can be done over a distance allowing highly automated identification, the transponders are not sensitive to dirt or

moisture, and there is a large number of unique identification codes or memory for coded data available. RFID offers also advanced security features and transponders can be hidden in the timber. Different utilization methods and scenarios of RFID based log tracking are discussed and compared in [2]. In this study it is concluded that the commercially most viable way to utilize RFID in the forestry supply chain is an open loop system using inexpensive transponders, i.e. the transponders are to be used only once and left in the timber.

Pilots and trials using RFID transponders for marking trees manually have been carried out using commercial HF and UHF transponder products and their suitability for this purpose has been evaluated for example in [3-5]. The conclusion in the trials has usually been that HF transponders are more suitable as their performance is less affected by moisture and rain outdoors than that of the UHF transponders. Another common conclusion observed in the trials is that the RFID transponders in the market have limited applicability for large scale tree or log marking partially because they were not intended for use in forestry. HF transponders have been used for automatic marking of logs in forest by a harvester when logs are cut – by inserting a glass transponder into a hole drilled into the log [6] or by stapling an HF transponder card onto the log end [7]. In both of these pilots there have been challenges in the automatic application of the transponders and with the limited read range of the HF transponders.

This paper describes an RFID log tracing system based on a novel passive UHF transponder specifically developed to the forest industry use for manual and automatic marking of timber and robust RFID readers for forest and saw mill use. Other traceability system components are also been developed such as software solutions [8-10]. The developed RFID reader and reader installations tailored for the use in the forest industry are discussed in this paper together with log marking test results at a saw mill.

II. RFID SYSTEM FOR THE LOG SUPPLY CHAIN

The forest industry sets a number of unique requirements for the RFID system, which include outdoor operation in harsh weather conditions in rough terrain or in a harsh industrial environment in saw mills, and limitations for the use of transponder materials. The electromagnetic properties of fresh wood are also challenging for transponder design; wet wood

has a high loss and the permittivity varies strongly with the moisture content of wood. Reading of the transponders is also challenging as heavy machinery with large metal surfaces is used, and such an electromagnetic environment poses challenges for the reader operation.

The basic log supply chain in the Nordic forest industry is illustrated in Fig. 1. After a tree is felled it is cut to logs by a harvester, and then a forwarder transfers the logs to a pile on the road side. Transportation to the saw mill is done by truck, train or by floating along the rivers and lakes. The logs are received and sorted by their characteristics such as their dimensions at the saw mill. Before sawing the logs are debarked. Measurement data of the logs is mainly collected at the harvesting, at the log sorting and prior to sawing into boards; inventories of the logs are done in the forwarding and during the transportation steps. RFID based log marking can be utilized to reduce the need for repeated measurements of the logs and to make the log inventory more automatic and efficient.

The RFID system consists of the transponders, readers and the necessary middleware for integration of the system to the information processing and production control system in the forest industry. RFID readers are needed in several locations along the supply chain to achieve complete traceability of logs. The developed RFID system described in this paper focuses on the identification of logs at the most important measurement points: harvesting, log sorting and sawing. In Section III, the requirements for a UHF transponder for log marking are discussed and the developed novel transponder meeting these requirements is described. Commercial solutions for mobile and fixed readers for operators and vehicles exist. Therefore, the focus in the reader technology development was at reader solutions for the most important measurement data collection points.

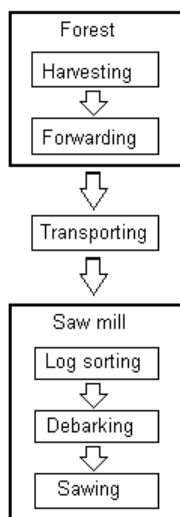

Figure 1. Nordic log supply chain.

The harvester felling the trees and cutting the logs is an especially challenging platform for a reader and a prototype of a robust UHF reader was specially developed for these conditions. Commercial readers and antennas were adapted for the saw mill environment. The readers are described in Section V and VI.

III. PASSIVE UHF TRANSPONDER

A. Requirements for the Transponder

The main requirements for a transponder suitable for log marking in the Nordic forest industry can be summarized as

- Readable; long reading range for automatic log identification and high survivability in the logs in the forest and at saw mills
- Pulpable; materials harmless in the pulp- and paper making
- Applicable; suitable for simple manual and fast automatic attachment to the logs
- Inexpensive; suitable for mass production and thus suitable for large-scale adoption in the forest industry

The basic requirement for all RFID transponders is that they need to be readable where they are used. Wood is an organic inhomogeneous material; the complex permittivity varies within and between logs due to variations in the moisture content, grain orientation and density. The logs are subjected to all-season outdoor conditions – rain, snow, ice and dirt, to repeated handling with forklifts and cranes, and to conveyor transportation. The best transponder survivability is achieved if the transponder is inserted into the log so that it is protected and firmly held in place by wood. The long reading distance can be achieved using UHF RFID technology and carefully designing the transponders for the moist environment.

The logs are sawn into boards at the saw mill and the wood that is not sawn or is left over in the sawing is usually chipped and sold for pulping mills to be used as raw material in paper making. Therefore, transponders or their pieces may end up in a pulping mill in the wood chips. In principle, no plastics, metals or coal is allowed in the wood to avoid contamination of the pulp that may cause problems in paper making or reduce the quality of the paper. The transponders may not contain significant amounts of plastics or metal in order to be compatible with the pulping and paper making processes. Some metal in the transponder is unavoidable as a highly-conductive material for the antenna is needed. The main part of the plastic in the transponder is in the casing containing the antenna inlay, and most of the harmful plastics can be eliminated using a pulping-friendly casing material. Hard artificial wood material, Arboform by Tecnar GmbH [11], is used as the transponder casing material. The material contains lignin, cellulose fibers (natural main ingredients of wood) and some processing aids. Although the material is biodegradable it has a relatively low water absorption, which makes it suitable for outdoor use as the logs are normally sawn within a few weeks from the felling. The material has also reasonably low electrical losses so it can be used as a transponder material.

In high volume applications the transponder has to be applied into the logs automatically by the harvesting machine. Means for manual transponder application into the logs is also needed for other uses in the forest industry, and for smaller scale adoption and tests in parts of the supply chain. The automatic application has to be fast so that the efficiency of the harvesting process is not significantly reduced and the manual working tool needs to be simple to operate. For easy application into a log the transponder has to be as small as possible without compromising the readability. The transponder position in the log end allows reading of the transponder also in log piles and in transportation loads.

B. Developed Transponder

The developed wedge-shaped transponder (patents pending) shown in Fig. 2 is optimized to operate inside wet wood. Moist wood is a challenging electromagnetic environment for an antenna; the typical moisture content of a freshly cut softwood log is of the order of 100 % (water content compared to the dry matter). At UHF RFID frequencies the dielectric constant ϵ_r is approximately 2.3 - 5 for samples cut from fresh logs and the loss tangent is of the order of 0.1. The electrical properties of wood vary strongly as a function of the moisture content and the moisture content varies between the logs and within a log. Therefore, the transponder antenna has to tolerate the varying complex permittivity of the surrounding media. The dielectric constant of the transponder casing material was measured to be 3.1 and the loss tangent was 0.030 at 867 MHz.

The transponder was designed using electromagnetic simulations of the antenna inside a log with HFSS by Ansoft using the simulator model shown in Fig. 3. The electrical losses of the transponder casing material limited the feasible antenna choices to dipole antennas.

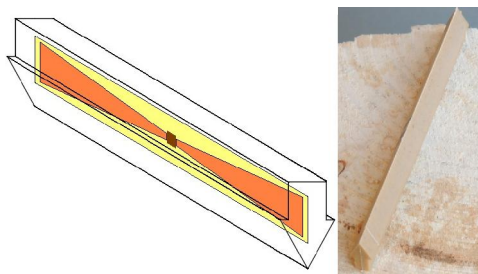

Figure 2. Wedge-shaped transponder

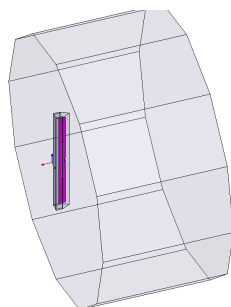

Figure 3. Simulator model of the transponder inside the log.

The designed antenna is a planar dipole antenna conjugate-matched to the RFID microchip (NXP Ucode G2XM). The basic antenna structure is presented in Fig. 4.

The transponder is suitable for inexpensive mass production as the wedge-shaped transponder casing encloses an inlay with the antenna etched on thin copper- or aluminum-plated PET-foil and a glue-bonded EPC Generation 2 Class 1 –compatible microchip. The casing is injection molded using common plastics manufacturing processes.

Several versions of the antenna were manufactured and prototype transponders with these antenna versions were molded. The reading range of the test transponders was measured in laboratory using test logs and readability tests were carried out at saw mills (discussed in Section VI). The reading range was measured using Voyantic Tagformance™.

The final antenna inlay design is 74 × 5 mm and it is fitted into a wedge-shaped casing of the size of 80 mm × 10 mm × 5.7 mm (length × height × width) as shown in Fig. 2. This size was found to be a good compromise between compact transponder size and performance. The measured reading range of this transponder design when inside moist wood is shown in Fig. 5.

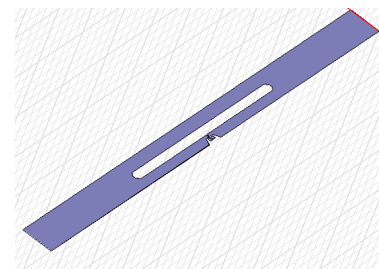

Figure 4. Planar dipole antenna for the transponder.

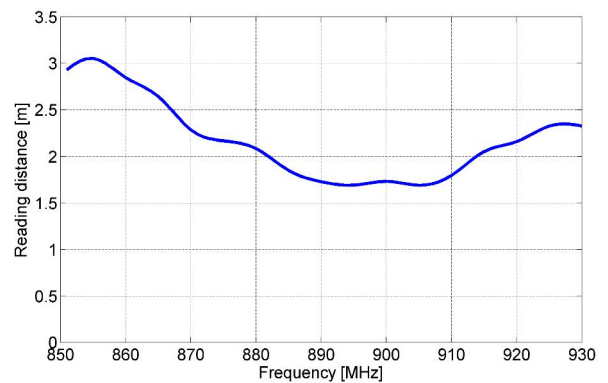

Figure 5. Measured reading range of the transponder.

The measured reading range inside a freshly cut log is approximately 2.5 m at the European RFID frequency band 865.6 - 867.6 MHz; reading range of over 1.6 m is achieved at 850 - 930 MHz covering most of the UHF RFID frequencies in the world. This reading range is sufficient for automatic log tracking in the timber supply chain, in [7] it is estimated that a reading range of the order of 1 m is needed in the forwarder for automatic log identification. Similar reading distances occur in the harvester and at the conveyors in the saw mills. However, a reasonable margin for the reading range measured in laboratory is needed to ensure good readability under actual conditions in the forest industry as the operation environment is far from ideal. Multiple reflections causing fading in the radio channel, presence of water and snow, and lack of direct line-of-sight tend to reduce the operation range.

IV. TRANSPONDER APPLICATOR

The wedge-shaped transponder is applied into the butt end of the log. This can be done either automatically in the harvester when the log is cut or manually at later stages of the timber supply chain. A prototype of the automatic applicator for a harvester is being developed by Rottne Industries AB in Sweden. Tools for manual transponder application have been manufactured by Bohult Maskin AB, Sweden. The application principle is illustrated in Fig. 6.

The transponder is hit into the fresh log and as the tool retracts the wood compresses around the transponder holding it tightly in the wood. The manual applicator tool is constructed from an axe with a transponder holder in the blade. Fig. 7 shows the application of a transponder into a log and a close-up of the transponder in the log end.

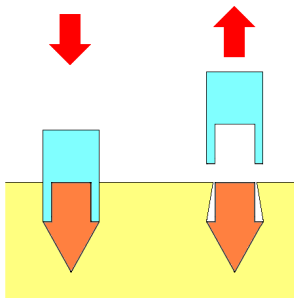

Figure 6. Application principle.



Figure 7. Manual transponder application and the applied transponder in the log end.

An experienced applicator user may apply approximately 100 transponders per hour into logs with a success rate of over 95 % with the first try. Application trials have been carried out in varying conditions both in winter and summer – at low temperatures in the range of -30°C the logs are much harder and a higher force is needed. Knots in the log may also break the transponder and the user should avoid them when hitting the transponder in.

V. RFID READER FOR THE HARVESTER

The RFID reader in the harvester head experiences high vibrations and mechanical shocks during tree felling and log cutting and the frequent sawing produces sprays of dust and oil. The Nordic weather exposes the reader to water, snow and ice, while temperatures vary from freezing winter morning of below -30°C to sunny summer afternoon of up to $+30^{\circ}\text{C}$.

The harsh environment imposed strict specifications on the mechanical structure of the reader. A robust cast-aluminum IP67 enclosure was used to ensure a fully dust-proof casing that is water-proof to the depth of one meter. The circuit board was mounted on a thick metal plate that was securely attached to the bottom of the aluminum enclosure, which was then filled with polyurethane resin. The structure provides mechanical rigidity for the PCB and the components, and eliminates possible problems due to moisture condensation inside the casing. To ensure operation at a wide range all components were selected to comply with the industrial temperature range of -40°C - $+85^{\circ}\text{C}$.

The reader antenna has to be mounted in close proximity to metal in the harvester head. The sprays of water, dust and oil, as well as the piling up of snow and ice on the reader antenna make the operating environment electrically very challenging. The extra dielectric material on the antenna, or in its close vicinity, tends to detune the antenna. This does not only decrease the radiated power, but also creates a strong, time-varying coupling from the transmitter to the receiver of the reader. This reflection is known to diminish the sensitivity of the receiver, causing lower read range and reliability [12].

The reader electronics shown in Fig. 8 consists of four main parts: the adaptive front end, the reader integrated circuit (IC), frequency generation, and the microprocessor (μC).

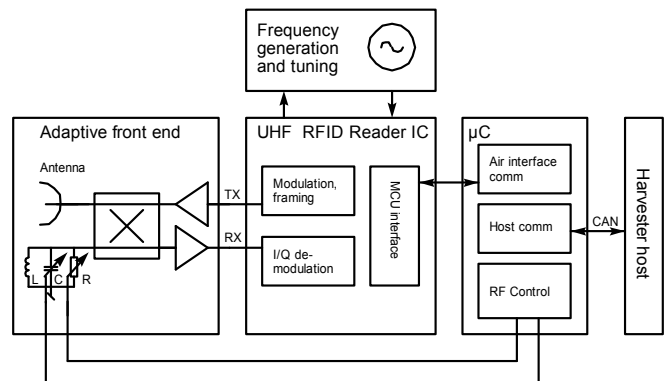

Figure 8. Block diagram of the harvester reader.

A novel adaptive RF front end was designed to isolate the receiver (RX) from the transmitter (TX). The operation principle of the front end can be simplified as follows: the DC component of the mixer output of the receiver is a measure of the carrier power incident to the receiver. This measured result is utilized to tune the variable load until no, or very little, carrier is present at the receiver input. The feedback operation is limited well below the signal frequencies to allow unhindered reception of the transponder signal. A detailed description of the hybrid-based isolator can be found in [13].

The embedded system of the RFID reader is implemented using a 32-bit ARM7 processor and the developed software consists mainly of three parts: a host communication module, an air interface communication module and an RF control module. The host communication module handles the communication media, CAN-bus in the harvester, and low level protocols as well as the reader management protocol, i.e. EPC Reader Protocol. The air interface communication module controls the reader-transponder interaction using EPC UHF Class 1 Generation 2 air interface protocol. The RF control module takes care of the RF front end of the harvester reader, including implementation of the software part of the novel adaptive front end.

The chosen ARM processor includes an internal CAN controller and has enough memory and capabilities to simultaneously handle the air-interface communication with tags, the EPCglobal Reader Protocol operations and the host communication over the CAN bus.

The operation of the reader is handled by the host communication module of the software. The harvester reader is controlled using the command/response operation mode. The host is expected to send commands and, if no commands are received, no operations are executed. Consequently, the RF control and air interface communication units are needed only when there are pending operations in the host communication module to read or access RFID transponders. Every time a log is marked, the harvester reader inventories the RFID tag population found in the RF field of the reader antenna and reports the results to the host software. The host system sends the information forward to be stored in remote databases.

The forest harvester where the reader is used, uses CAN network and proprietary CAN protocols and utilizes only a simplified CANopen interface to be used by the RFID reader. A proprietary CAN Application level protocol was developed to enable a transparent transmission medium for the EPC Reader Protocol messages.

Furthermore, the marking of the logs and the reading of the RFID tags must be synchronized. Therefore, a real-time operation is required from the RFID reader during the transponder inventory to fulfill the strict time constraints of both the EPCglobal air interface protocol and the harvester operations [14].

The reader was tested for environmental resistance according to the highest shock and vibration levels specified in ISO 15003 (50 G shocks, 2 G vibrations at 10-2000 Hz). The reader operated normally during the tests. The operation under

outdoor temperatures was also tested. The reader circuit board operates normally in the temperature range $-20^{\circ}\text{C} \dots +80^{\circ}\text{C}$, but additional reset-commands had to be sent to the reader circuit board in the temperatures of -20°C to -40°C . In laboratory conditions with a regular RFID patch antenna and common commercial tags the reader provides a reading distance of 4 to 5 meters with $2 W_{\text{erp}}$ transmitted power, which is comparable to commercial readers.

The reader was installed on the harvester together with a specially designed, compact and impact resistant reader antenna for testing in realistic conditions. The antenna installation is shown in Fig. 9. The read range of the system when reading tags applied to the end of a fresh log varied between 0.3 m and 0.5 m with about $1 W_{\text{erp}}$ of transmitted power. The low read range, as well as the high variation of it, can be explained by the varying moisture content of the logs and variations in transponder position and orientation, and by reflections inside the harvester head causing variation in the signal strength.

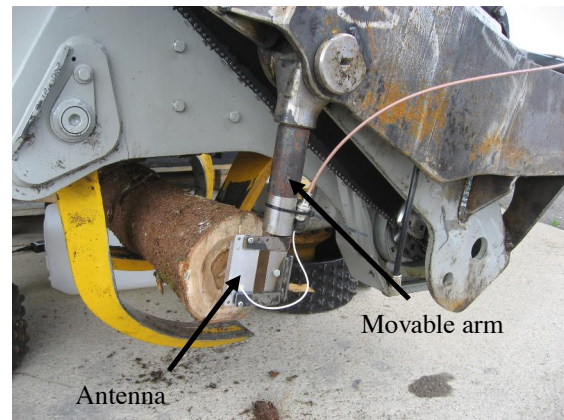

Figure 9. Reader antenna on a movable arm in the harvester head.

VI. READABILITY AT SAW MILLS

The performance of the RFID system was evaluated with transponder readability tests under actual conditions at two saw mills. RFID readers were placed at the saw mill at two locations: at log sorting where the logs are received and at the saw intake where the logs are sawn into boards. At these two locations the log dimensions and shape are measured with a 3D-scanner. Fig. 10 shows the log sorting reader set-up in Sweden. The logs are unloaded from trucks and sorted when received by the saw mill. The antenna frame shown in Fig. 11 was assembled around the log conveyor at the saw intake of a saw mill in Finland to identify the logs to be sawn. In both cases, the distance between the reader antenna and the logs is less than 1 m. Sirit Infinity 510 readers were used with three or four circularly polarized antennas. The fourth antenna was found to be mostly redundant.

Table I summarizes the reading tests. In the log sorting reading tests 82 logs were marked with the UHF transponders in both log ends and the same logs were sorted and identified twice. In the saw intake log identification test 143 logs were marked with transponders only in the butt end of the log. The read rate is the number of read transponder compared to the



Figure 10. Reader antenna set-up at the log sorting.



Figure 11. Reader antenna set-up at sawing.

TABLE I. READABILITY TEST RESULTS AT SAW MILLS.

Test	Number of tags	Read rate	Number of readings per transponder	Standard deviation
Log sorting test 1	164	100 %	190	120
Log sorting test 2	164	99.4 %	180	120
Sawing	143	99.3 %	390	150

total number of transponders in the test. The number of readings tells how many times on average the reader received the EPC code of a tag when the tag passed the reader once. The average number of the readings per tag and its standard deviation were found to be a good measure of the readability of the transponder at a reading location and these figures provide a simple way of comparing reader set-ups or transponders.

In the log sorting tests the same batch of marked logs was used twice and one transponder in the second run was not read. It may have been broken during the log handling. Similarly, in the sawing test the logs were marked several days in advance at the log yard and one transponder may have been damaged during the extra handling of logs needed for the marking of the logs. The conveyor speed was approximately 55 - 70 m/min at the sawing and 90 - 120 m/min in the log sorting, respectively. The number of readings corresponds approximately to the time that the marked log spends in the fields of the reader antennas at these two locations. The metal floor and other structures in the log sorting station cause multipath propagation and rapid fading in the signal of the reader. This causes the higher deviation in relation to the average number of repeated readings for the transponders at this site.

VII. CONCLUSIONS

Forest industry presents unique challenges in the RFID system design and development. UHF RFID technology enables automatic identification and tracking of timber allowing improved control of the production and the origin of the wood. The all-weather outdoor conditions and the harsh industrial environment at saw mills require specialized technical solutions. Therefore, novel pulping compatible passive UHF transponder made of a wood composite material was developed for marking of logs together with robust RFID readers for the harvester and saw mills.

The 80-mm long wedge-shaped transponder is inserted into the log end so that it is protected by wood. The transponder has a measured reading range of approximately 2.5 m from fresh moist logs. The transponder is mass-producible by injection moulding, and the materials are compatible with pulping.

A robust RFID reader for identifying the logs during the harvesting was developed. The reader features a water- and dust-proof IP67 casing and it was tested to operate normally when subjected to 50 G shocks and 2 G vibrations at 10 - 2000 Hz corresponding to the conditions in the harvester head during tree felling. To improve the reliability of the reader, an adaptive RF front end compensates the varying reflections

from the nearby metal objects as well as the reader antenna detuning by water, ice and other dielectrics. The reader has functioned as designed in the field tests in the harvester.

Readability tests under actual conditions in two saw mills were carried out. High readability of the transponders in test logs was observed; the read rate was nearly 100 %. The main factor affecting the transponder readability is their survival in the logs in the timber supply chain.

The work has shown that the developed UHF RFID technology provides for a technically feasible tracking platform for the forest industry. Further improvement is needed in the automatic applicator of the transponders to maintain the high efficiency of the harvesting process..

ACKNOWLEDGMENT

Mr. Matti Ritamäki from Confidex Ltd, Dr. Kari Kolppo and Ms. Eeva Reunanen from Tampere University of Technology are thanked for their contribution in the development of the transponder manufacturing. The authors are grateful to Mr. Olli Raunio from Raunio Sawmill and Mr. Bo Andersson from Setra Malå sawmill for arranging the opportunity to test the RFID system under actual conditions at the saw mills.

REFERENCES

- [1] D. P. Dykstra, G. Kuru, R. Taylor, R. Nussbaum, W. B. Magrath, J. Story, "Technologies for wood tracking," Environmental and Social Development East Asia and Pacific Region Discussion Paper, World Bank ,2002.
- [2] D. Timpe, RFID in Forestry: Prospects of an RFID-based log tracking system as an alternative to stamping, Mid Sweden University, Sundsvall, Sweden, FSCN-rapport R-06-63, ISSN 1650-5387 2006:39, 2006.
- [3] N. Mohamed, A. H. Garoot, Z. M. Hazza, "A case study on impact of RFID adoption in tree inventory management," *2nd IEEE International Conference on Computer Science and Information Technology (ICCSIT)*, 8-11 Aug. 2009, pp. 624-628.
- [4] T.-W. Jung, J.-M. Koo, K.-M. Kim, M.-W. Pyeon), "Research on RFID system recognition test under the forestry environment for tree management," *Fifth International Joint Conference on INC, IMS and IDC*, 25-27 Aug. 2009, pp. 1180-1184.
- [5] S.-S. Lin, T.-C. Wu, J.-S. Wu, Y.-P. Huang, M.-H. Chang, S.-W. Fan, J.-J. Liao, "POC of RFID application in forest sample zone investigation," in *Global Perspective for Competitive Enterprise, Economy and Ecology*, S.-Y. Chou, A. Trappey, J. Pokovski, S. Smith, Eds., London, United Kingdom, Springer, 2009, part 10, Proceedings of the 16th ISPE International Conference on Concurrent Engineering, pp. 541-552.
- [6] R. Uusijärvi, "Environmentally Sustainable and Efficient Transformation processes (LINESET)," SP Technical Research Institute of Sweden, Wood Technology (SP Trätekt), QLRT-1999-01476 Final Report, Research Report no. P 0309034, 2003.
- [7] S. Korten, C. Kaul, "Application of RFID (radio frequency identification) in the timber supply chain," *Croatian Journal of Forest Engineering*, Vol. 29, No. 1, 2008, pp. 85-94.
- [8] <http://www.indisputablekey.com>
- [9] A. Sirkka, "Modelling traceability in the forestry wood supply chain," *IEEE 24th International Conference on Data Engineering Workshop (ICDEW)*, 7-12 April 2008, pp. 104-105.
- [10] A. Björk, M. Erlandsson, J. Häkli, K. Jaakkola, Å. Nilsson, K. Nummila, V. Puntanen, A. Sirkka, "Monitoring Environmental Performance of the Forestry Supply Chain using RFID," submitted for publication.
- [11] <http://www.tecnaro.de/english/willkommen.htm>
- [12] P. Pursula, M. Kiviranta, H. Seppä, UHF RFID Reader with Reflected Power Canceller, *IEEE Microwave and Wireless Component Letters*, Vol. 19, No. 1, pp. 48-50, Jan. 2009.
- [13] P. Pursula, I. Marttila, K. Nummila: Wideband adaptive isolator for UHF RFID reader, *IEE Electronics Letters*, Vol. 45, No. 12, pp. 636-637, June 2009.
- [14] M. Huusko, Embedded System for the Networked Real-Time RFID Reader, M.S. thesis, Helsinki University of Technology, Espoo, Finland, 2009.