

Title Design, Implementation and  
Experimental Results of a Wireless  
Sensor Network for Underground Metro  
Station

Author(s) Hiltunen, Jouni; Valta, Mikko;  
Ylisaukko-oja, Arto; Nurchis, Maddalena

Citation International Journal of Computer  
Science & Communication Networks  
vol. 4(2014):3, pp. 58 - 66

Date 2014

URL <http://www.ijcscn.com/vol4issue3.php>

Rights Copyright © (2014) IJCSCN.  
This article may be downloaded for  
personal use only

<p>VTT <a href="http://www.vtt.fi">http://www.vtt.fi</a> P.O. box 1000 FI-02044 VTT Finland</p>	<p>By using VTT Digital Open Access Repository you are bound by the following Terms &amp; Conditions.</p> <p>I have read and I understand the following statement:</p> <p>This document is protected by copyright and other intellectual property rights, and duplication or sale of all or part of any of this document is not permitted, except duplication for research use or educational purposes in electronic or print form. You must obtain permission for any other use. Electronic or print copies may not be offered for sale.</p>
---	---

## Design, Implementation and Experimental Results of a Wireless Sensor Network for Underground Metro Station

Jouni Hiltunen, Mikko Valta, Arto Ylisaukko-oja, Maddalena Nurchis  
 VTT Technical Research Centre of Finland -Kaitoväylä 1, 90571 Oulu, Finland  
 Jouni.Hiltunen@vtt.fi, Mikko.Valta@vtt.fi, Arto.Ylisaukko-oja@vtt.fi, ext-maddalena.nurchis@vtt.fi

### Abstract

*Wireless sensor networks provide a prominent approach for environmental monitoring system in many different scenarios. Typically, sensors communicate through a mesh network architecture, in which each device functions also as a relay for other devices. The usage of multi-hop wireless paths raises the challenge of achieving robust communication and low energy consumption while optimizing the system maintenance costs due to battery replacements and network management. In this paper, we present the design and implementation of a wireless monitoring system deployed in an underground metro station, developed as a flexible cross-layer solution able to integrate time synchronization, duty-cycling and lightweight routing mechanisms. We provide detailed description of the system together with experimental results on the achievable energy efficiency improvement and on the adaptability of the routing protocol to the dynamicity observed in the station environment, providing relevant insights into properties and challenges of real WSN deployments.*

### 1. Introduction

Wireless sensor networks (WSNs) provide a prominent approach for environmental monitoring systems. Typically, a WSN consists of a set of wireless sensor nodes - containing radio transceiver, sensing components and data processing system - and a back-end infrastructure that enables the gathering and further processing of the sensor node measurement data. The advantages of WSNs derive from the easy installation they enable: the system can be deployed mostly without communication and power wirings, which could restrict the installation location of the sensor nodes or prevent the

installation because the wiring is not achievable or it is too expensive to deploy. The potential drawbacks of WSNs include less robust operation in terms of wireless data delivery and the risk of increased maintenance cost because of battery replacements.

The applicability of the WSN approach depends also on the duration of the monitoring campaign as well as the system requirements that are the basis for the cost-benefit analysis. In addition, the dynamicity of many of the typical operating contexts can significantly affect the radio communication. Therefore, experimental results of WSN deployments, together with a sufficient description of the implemented energy efficient communication protocols, provide valuable information for promoting the possibilities of such advanced measurement systems in the future.

In this paper, we describe the design and implementation of a real WSN-based monitoring system deployed in an underground metro station, where we observed that dynamic station conditions influence system performance. We propose a cross-layer solution able to combine time synchronization, duty-cycling and routing schemes in a restricted operational time period in which nodes are in active mode, with the main objective of energy efficiency and reliable packet transmission. Preliminary results on data delivery and energy consumption show the potentiality of our system to reach the desired target despite the challenging conditions, and provide useful observations on the characteristics of such scenarios. We briefly overview some of the existing works on WSN in section 2. Then, we present our system in detail in section 3 and experimental observations in section 4. Finally we conclude with section 5.

### 2. Background

The pilot deployment was done in the scope of the EU FP7 research project called SEAM4US [1] in a metro station located in Barcelona operated by

Transports Metropolitans de Barcelona. The demand for indoor environmental monitoring in a metro station emerged fundamentally from ambition towards more sustainable development and forecasts of increase in energy cost, as the goal was to save substantial amount of energy through optimal control of the station subsystems, such as ventilation and illumination. The WSN was used for gathering real-time information about ambient conditions of the station to provide feedback to facility automation control, as well as to control strategy development through station modelling, as described by Ansuini et al [2].

WSN deployments have been analysed in the literature in many different use cases, usually with customized hardware and communication protocols [3][4][5]. A complete overview of the rich literature is out of the scope of this paper, thus we briefly discuss some of the works related to the main aspects encompassed in our solution.

Wireless sensor networks are considered as an effective low-cost and flexible solution for monitoring purpose in many different contexts [6][7][8][20][21]. In [6], the authors describe a building monitoring system designed to assess earthquake damage. Strain sensing modules are located at the lowest level, acceleration sensing modules are placed at all floors, and a set of dedicated routers is distributed among floors to allow multi-hop data sending from sensors to a central base station. The validation of the system is performed in a laboratory setup with earthquake simulation, showing good correlation between accelerometer signal output and reference signals as well as the need for individual calibration for strain sensors. The work presented in [7] is focused on data reduction and energy minimization in a WSN deployed in India for landslide detection. To this aim, the set of devices sensing the maximum values are identified, and the rest of the nodes are switched off for an estimated period of time, showing performance improvement in terms of data transmitted, energy consumption and battery lifetime. Moreover, the authors adopt multiple policies to dynamically change the measurement frequency: setting the rate based on a forecast model leads to longer battery lifetime than technique based on simpler thresholds.

Our solution is based on an energy efficient MAC protocol called R-MAC, which is proposed by Koskela et al. [9]. R-MAC is basically a cross-layer approach in which the radio and the underlying MAC protocol is duty-cycled by R-MAC based on requisite data sampling rate and the delay requirements of the prevailing application. R-MAC can turn off the radio during the network idle times when transmissions in the network are not

expected. Therefore, low duty-cycles can be achieved, especially if the nodes periodically send data towards the gateway node in long intervals (>30 s) and the transmissions are synchronized.

Another challenge, especially in underground metro WSNs, is achieving robust packet delivery in spite of peculiar environmental conditions and sensor nodes installation. Wang Qianping et al. [10] propose a hybrid network approach suitable for underground laneways, in which dedicated relay nodes bear most of the long distance communication. Jin-ling Song et al. [11] enhance radio interfaces by OFDM modulation and V-MIMO (Virtual Multiple Input Multiple Output) node co-operation technique to increase capacity of the wireless channel suffering from serious diffraction, attenuation, multi-path and scattering in underground coal mines.

Recent underground metro WSN case studies are presented by Liu Qiong et al. [12] and Jae-Woo Nam et al. [13]. Liu Qiong et al. propose an architecture for metro rescue system focusing on data collection strategy of the sink, data transport control protocols and network quality of service. Jae-Woo Nam et al. developed a wireless measurement system for ventilation control of a metro station in which they focus on evaluation of PM10 measurement solutions and radios operating in 424MHz and 2.4GHz frequencies.

The innovative contribution of our work is that it integrates three essential mechanisms for WSNs in a flexible cross-layer solution, which can achieve multiple objectives and can be remotely configured to adapt to the variable environment. In addition, the experimental investigation gives precious insights on issues specific to real deployments in underground metro station contexts and shows some promising observations.

### 3. System design

The system design was based on a set of use case requirements and assumptions about the operating environment that are described below. The rationale for the sensor requirements and positions are presented by Ansuini et al. [14].

- A wireless approach was selected because the metro station is a public space located underground, which hinders the wiring installations considerably, and because many of the sensors were installed temporarily for system development purposes.
- The sensor nodes are battery powered and the battery replacement interval should not be less than five years. In our use case, the energy harvesting was not implemented since the data of the suitability of the ambient conditions for

cost-effective energy harvesting was not available and we did not want to restrict the locations of the sensor nodes. The energy harvesting may be used to complement our battery powered solution in the future.

- The WSN form a dense topology in which 2.4GHz radio operating in ISM frequency range provides a sufficient communication range for each node to reach a neighbour node, while mesh routing can be utilized to connect each node to the gateway node.
- A metro station is considered a dynamic radio environment because of narrow thick-walled corridors that may be almost completely blocked by passengers and trains. This environmental variability is considered because Turner et al. [15] show that the presence of people moving in indoor significantly affects the signal strength in the used radio technique.
- In order to minimize manual intervention and to increase flexibility and adaptability of the system, the WSN must have sufficient self-configuration properties that enable complete remote control of the system.
- Sensing measurements are performed every minute and must be available at the server PC for post-processing every ten minutes. However, the sensor sampling rate must be managed remotely for system control. The maximum desired data loss is 10% because the environmental factors sensed in this scenario, such as temperature, do not change significantly over such a short-time period.

### 3.1. System overview

The system architecture overview is depicted in Fig. 1, where we can identify two types of wireless nodes. The Gateway Node (GW) communicates with the gateway server PC through RS485 and forwards measurement data from the nodes to the server and management data from the server to the nodes; the Sensor nodes communicate with each other through ZigBee radio (IEEE 802.15.4), providing mesh routing capability. The sensor nodes may contain multiple sensing components for environmental measurements, and transceivers to communicate with the gateway node and other sensor nodes. The weather station is a special type of environmental monitoring component since it is based on a single off-the-shelf device. It sends the measurement data through a RS485 link to gateway server. The gateway server is accessible from the internet through a virtual private network access.

### 3.2. Node design

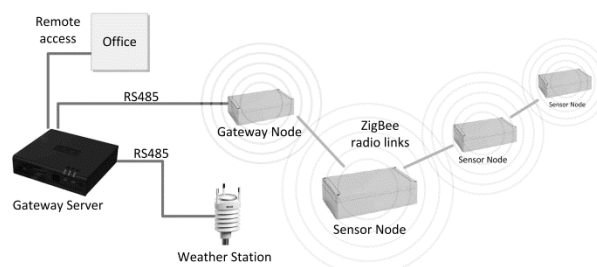
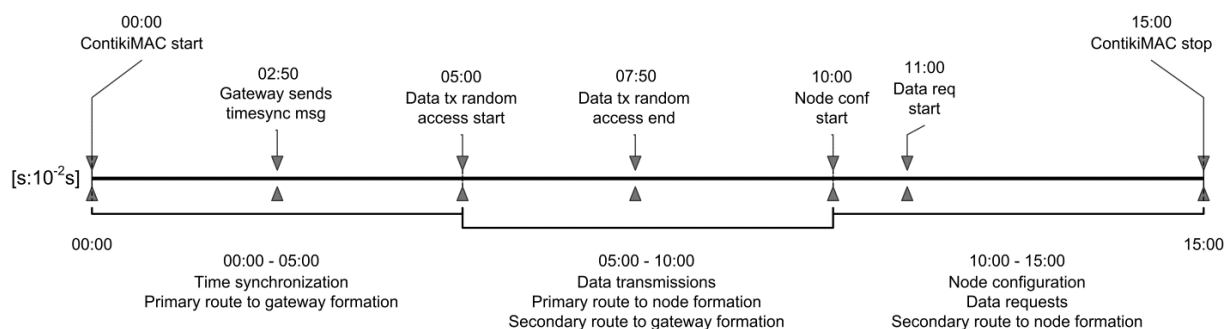

Figure 1- System architecture overview

Both the gateway node and the sensor nodes are implemented on a commercially available processing and communications board by Redwire LLC, called Econotag. This board includes an ARM7 based system-on-chip by Freescale, namely MC13224V, which includes an ARM7TDMI-S processing core and an IEEE 802.15.4 compatible 2.45 GHz short-range radio transceiver. The MC13224V has a total memory of 96 kB divided flexibly between program code and RAM memory. In addition, MC13224V has the IEEE 802.15.4 MAC layer readily implemented in ROM.

The Econotag board is supplemented with an additional 32 KHz oscillator and a sensor board of our own design. Four different sensor board types were designed, each containing several different sensors. There is also an RS485 interface implemented on each of the sensor boards, enabling them to act as a gateway node when needed. The sensor boards also include voltage regulation (voltages depending on the sensor requirements on each board type) and a power switch. The sensor board types are as follows:

1. Sensor Board 1: surface temperature sensor, air temperature sensor, bi-directional rotating vane anemometer, absolute air pressure sensor.
2. Sensor Board 2: carbon dioxide sensor type 1, absolute pressure sensor, PM10 sensor (particulate measurement, type 1), relative humidity sensor.
3. Sensor Board 3: surface temperature sensor, differential pressure sensor, low speed hot-wire anemometer
4. Weather Station Board: solar radiation sensor (pyranometer), carbon dioxide sensor type 2, PM10 sensor (particulate measurement, type 2). The sensor node based on this board supplements the commercial off-the-shelf weather station with additional sensors.



**Figure 2- Communication protocol operation timeline**

The majority of the sensor nodes in the network are based on Sensor Board 1. In the current system, this is also the only sensor node type that is battery operated; the others have batteries only as a backup power source for situations where wired power supply is temporarily lost. In part, this is because the other sensor board types include sensors that are power hungry due to relatively high power consumption and long stabilization time. On the other hand, these sensors typically operate also as gateway nodes at the same time and therefore have wires installed anyway.

The power consumption of Sensor Board 1 is kept to the minimum by switching on only the required sensors and only for the short period of the measurement. This is controlled by the software residing on the MC13224V's microcontroller. Power save modes of each sensor are utilized when available, or dedicated MOSFET power switches are used to power down a sensor completely. To achieve lowest energy consumption for the Econotag board, the on-board UART IC and linear regulator were also disconnected.

Software in the gateway node and sensor nodes are running on Contiki OS [16], which is an open-source operating system written in C being under development since 2002. It provides functions such as memory handling, event processing, energy usage profiling and protocols - e.g. medium access control, multi-hop communications and duty cycling for multiple embedded hardware platforms - in addition to generic network applications.

### 3.3. Communication protocol design

The main idea behind our system design was to achieve sensor nodes energy efficiency and reliable packet delivery in a dynamic environment, which led to a compact cross-layer solution as depicted in Fig. 3. The monitoring system relies on three main features: 1) network time synchronization, 2) efficient duty-cycling, 3) lightweight routing. The timeline of each node is organized as a set of subsequent network transmission intervals, each of them consisting of a sleeping mode period and a 15

seconds active network period, in which the three above components operate, as showed in Fig. 2. The 15 seconds duration for the active network period was found suitable as it enables sufficient time-frames to perform radio channel random access, retransmissions and transmission backoffs caused by network congestion. The network transmission interval is determined by the sensor network management software as the highest common nominator of all node transmission intervals, i.e. time periods in which each node sends the measurements to the gateway node, based on the specific node's application.

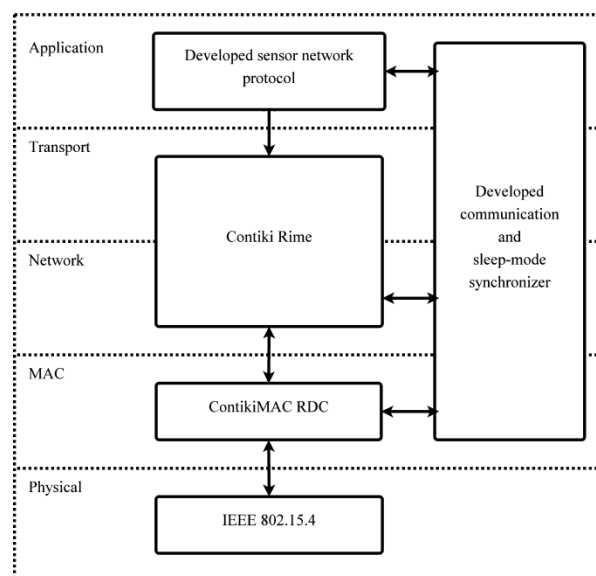

**Figure 3 - Communication protocol stack**

The first essential requirement is time synchronization: the whole network must be in active mode at the same time to enable mesh routing. Moreover, it allows the sensor nodes to timestamp each measurement that may be transmitted later towards the gateway server. The gateway server, gateway node and sensor nodes are time synchronized based on the gateway server clock, which is maintained by a standard network time protocol defined in RFC 5905. The time

synchronization is achieved through periodic broadcast transmissions initiated by the gateway node. The packet includes a timestamp that indicates the current time as well as the network transmission interval. Each node forwards the packet with the updated synchronization information. The accuracy of the time synchronization protocol is usually  $\sim 20$ ms, which was found convenient because the time resolution of the nodes is 10ms. However, the accuracy depends on the difference of ambient conditions between nodes and on the time update interval. For example, 20ms accuracy can be easily achieved if the update interval is 5 min and the ambient conditions do not change drastically in the network because of time-counting 32 KHz crystals included in the nodes. An additional failure recovery mechanism is used because network operations are based on time synchronized sending intervals. Therefore, the node keeps count of the missed time synchronization packets and reboots if predefined amount of packets are missed. After the reboot, the node's duty cycling is based only on ContikiMAC protocol until the node is synchronized. In addition, failures caused by software loops are recovered by a hardware watchdog timer.

The developed duty-cycle mechanism enhances ContikiMAC [17], which is a Contiki OS MAC implementation that enables a continuous duty cycled operation. Based on periodic sampling of the radio interface, it is able to put the node in sleep mode most of the time, while ensuring communication with other nodes in the network. In the default configuration, it turns on the node to active mode every 125ms to find out if there are transmissions to be received. Therefore, each transmission must be repeated a minimum number of times to be sure that the receiving node is in active mode during the transmission. In case of unicast communication, it is possible to optimize the number of required transmissions, e.g. by storing the duty cycle phase of the neighbour nodes and timing the packet sending based on this information. However, broadcast packets must be sent always extensive number of times to ensure that all reachable nodes will be in active mode during the transmissions. Inspired by the R-MAC principle, our duty-cycle protocol enhances the energy efficiency of ContikiMAC by disabling it during idle network periods -when not in active network period- and keeping the nodes in sleep mode if no data processing is needed.

When utilizing the described duty cycle protocols, the battery replacement interval depends mainly on the network transmission interval. In practice, each node is configured with a multiple of smallest transmission interval needed in the

network to optimize the network transmission interval. Fig. 4 depicts the battery replacement interval based on the following parameters, assuming energy consumed during data processing in idle network periods is negligible:

- Battery capacity: 2900 mAh (@3V, linear discharge based on Energizer L91 AA Lithium battery [18])
- Sleep mode current consumption: 0.02 mA (based on our measurements done with nodes)
- Average active mode current consumption: 30 mA (based on our measurements done with nodes)
- ContikiMAC duty-cycle: 5% (based on our measurements done with the deployment setup)

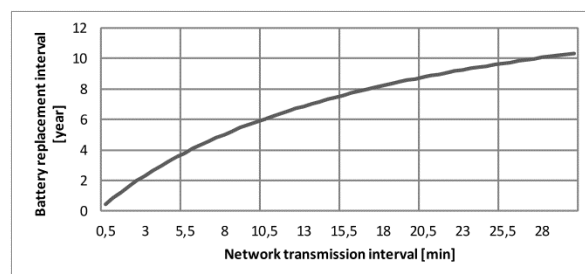

**Figure 4 - Battery replacement interval**

The routing protocol definition was driven by two main principles: low complexity and dynamicity. The former aims to minimize the computational burden and storage requirement of resource-limited sensor nodes, with the main objective of energy efficiency. The latter is required to properly adapt routing decisions to the variability of environmental conditions, as partly shown in the experimental results. For this purpose, multi-hop routes from sensor nodes to the gateway node are formed at the beginning of each active period. In order to minimize traffic due to routing, paths are usually discovered by taking advantage of packets exchanged among nodes, relying on explicit routing procedure only when really needed. In more details, routing information is piggybacked on broadcast time synchronization and unicast data packets. Time synchronization packets include end-to-end route quality information of the traversed path, which is based on the Link Quality Indicator (LQI) calculated on the radio chip and on the hop count of the received packet. The end-to-end cost is updated each time the packet is rebroadcasted as follows: if, in the last hop,  $LQI < 25$  then add 10, else if  $LQI < 45$  then add 3, else add 1. The values were chosen after a preliminary experimental analysis of LQI-packet loss correlation carried out on a smaller test-bed. The main goal was to identify

and avoid poor links without requiring complex metric computation.

Similarly, the primary method of determining the route toward each sensor node is based on data transmissions. When the gateway node receives a data packet or a sensor node is requested to forward a packet towards the gateway node, the last hop information is stored in the node's routing table leading to up-to-date multi-hop paths. Motivated by simplicity and energy efficiency requirements, we do not take into account potential link asymmetries. However, the preliminary results shown in this paper do not highlight any performance limitation due to this assumption, the investigation of which is left as a future work.

The secondary method of determining the multi-hop routes is triggered only if the node or the gateway wants to transmit a packet but a suitable route in the routing table is not found. In this case, Contiki OS mesh multi-hop routing is utilized, which is based on the on-demand routing protocol AODV that involves broadcast route-request packets and unicast route-reply packets. The main application protocol configuration parameters for each sensor are the measurement and transmission intervals as well as measurement options, such as periodic measurements, transmitting measurement if defined thresholds are exceeded and on-request measurements. For each node the user initiated setups include options for node reset and over-the-air re-programming.

### 3.4. Application protocol design

The developed application protocol enables the self-configuring and remote management of the WSN. The protocol is based on open-source implementation available in [19] and therefore it encompasses a wider scope than the current requirements of the use case. The message types and their purpose are described in Table I.

## 4. Experimental results

The WSN deployment consists of 35 sensor nodes and 5 gateway nodes with total of 80 environmental sensors in a rather complex environment including underground corridors, halls, stairs and a metro platform. Each sensor node is associated with a single gateway node to form separated radio subnets in terms of utilized 802.15.4 radio channels to reduce interference between subnets.

For the purpose of the evaluation, we considered hourly packet delivery ratio for each sensor and estimated hourly passenger occupancy at the station provided by the metro operator. Each

data packet sent by the nodes includes also the next hop information of the route towards the gateway node, which enabled analysis of the routing end-to-end paths. In subsections A and B the data was gathered during 12 and 4 working days, respectively.

**TABLE I**  
**APPLICATION PROTOCOL MESSAGE TYPE**

Message	Source	Dest	Description
JOIN	node	GS	Join the network
REQC	GS	node	Set the configuration parameters for each node
REPC	node	GS	Acknowledge REQC message
DATA	node	GS	Send measurement data
REQDATA	GS	node	Request measurement data from sensors
PROG	GS	node	Re-program nodes over-the-air
ACK	node	GS	Acknowledge reception of PROG message

**TABLE II**  
**MAIN CONTIKIOS COMMUNICATION PROTOCOL SETUP**

Parameter	Value	Description
NETSTACK_NETWORK	rime	Rime network stack is used
NETSTACK_MAC	csma	MAC driver applies a carrier sense multiple access
CSMA_MAX_TRANSMISSIONS	3	Maximum number of retransmissions in case packet loss is detected in MAC driver
NETSTACK_RDC	contiki mac	ContikiMAC power-saving driver is used as radio duty cycling (RDC) protocol
SHORTEST_PACKET_SIZE	43	Minimum packet size
RDC_CHANNEL_CHECK_RATE	GS	RDC radio sampling frequency
WITH_PHASE_OPTIMIZATION	node	ContikiMAC phase optimization was not applied

It is worth highlighting that the objective of this section is to provide some preliminary observations on the influence of station dynamics on routing decisions and packet loss. Due to space constraints, a complete analysis is out of scope of this paper, but it is part of our ongoing work.

In Table II and Table III, the main communication and application protocol setups are presented.

**TABLE III**  
**Main application protocol setup**

Parameter	Value	Description
MEAS_INTERVAL	60 s	Interval of periodical measurement
SEND_INTERVAL	180 s	Interval of sending data towards gateway server
MIN_NET_WAKE_UP_TIME	15 s	Active network period duration
MAX_MEAS_DATA_IN_DATA_PACKET	4	Number of measurements stored in a single aggregated DATA packet
MISSING_DATA_REQUESTS	enabled	Gateway server makes a data request in case of packet loss
MISSING_DATA_VERIFIER_PACKET_LIMIT	20	Number of previous measurements in which the MISSING_DATA_REQUESTS is based on

#### 4.1. Unipath routing

The experimental evaluation is based on the governing assumption that the deployment environment's radio conditions are dynamic because of the passenger occupancy variance at the station. In Fig. 5, a part of the deployment is presented to back up our assumption. This section of the WSN was selected because the gateway node (GW) in question was serving only 4 nodes with total of 8 sensors and the routes towards the GW were stable over time, which reduces the variable effect of communication protocols to the packet delivery ratios. Route from node 34 to GW was formed via node 33 with a line-of-sight radio link between the nodes 33 and 34. Route from node 4 and 3 to GW was formed through a router without line-of-sight links.

The overall packet delivery ratios for the nodes 3, 4, 33 and 34 were 86%, 62%, 99%, and 99%, respectively. Most of the packet loss for nodes 3 and 4 was happening during high passenger occupancy hours (peaks at 9:00 and 19:00) with normalized covariance in (format: {normalized covariance, p-value, 95% confidence interval}) between packet delivery rate and passenger occupancy levels for node 3: {-0.5, 4e-09, -0.6, -0.3} and for node 4: {-0.7, 7e-21, -0.8, -0.6}. Since the node 33 and the router are out of their communication ranges, a hidden node problem might explain some of the packet loss. However, the hidden node problem alone is not causing the packet loss because during low passenger occupancy there is no such packet loss present. Therefore, it is concluded that the passengers may

cause disturbances to the radio communication between some nodes.

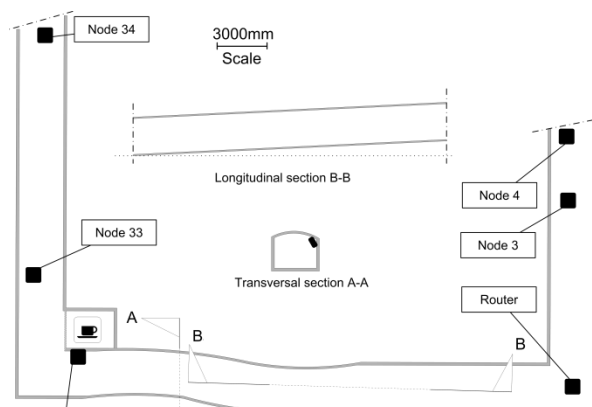

**Figure 5 - Deployment schematics for a U shaped underground corridor**

#### 4.2. Multipath routing

In order to investigate more on the effects of station dynamics on radio conditions, we focused on the sensor nodes located on the metro station platform, depicted in Fig. 6, where passenger occupancy and train crossing can particularly affect radio propagation, by causing phenomena such as signal refraction and interference.

Based on station opening/closing time, train schedule and passengers occupancy estimation, we define day time from 06:00 to 23:59, and night time from 00:00 to 05:59. We concentrated on two metrics and observed the difference between values over day and night. The Packet Reception Ratio (PRR) reports the percentage of packets correctly received at the gateway server from each node, and the Next Hops Number (NHN) is the total number of (neighbour) nodes that have been selected as next hop to reach the gateway node. Motivated by the tendency in routing decisions - some next hops selected only a negligible number of times, i.e. less than 10% - we decided to consider and compare the number of next hops selected at least once and those selected at least 10% of the time (specified as "0.1" in the graphs). Due to space constraints, we do not include analysis of next hop selection probability and of cost and number of hops of routing paths.



Fig. 7 reports CDF and per-node values of the above metrics. PRR values are considered satisfactory, as losing not more than 10% of data does not make a valuable difference in our scenario. The only exception is node 21, which is in a peculiar location where line-of-sight signals to other nodes are usually covered by trains, thus packet loss percentage during the day is slightly higher (approx. 13%). As expected, PRR and NHN distribution during the night are shifted around higher and lower values respectively, as the station is empty. In addition, during the night, the nodes closer to the gateway node (25,26,28 and 29) select that node as the next hop with a very high probability (ranging from 0.86 to 0.99), whereas all the other nodes often have to rely on more (multi-hop) paths also during the night. We noticed that for the nodes farther from the gateway node, the cost to reach it is usually similar when passing through any of the nodes that are selected most of the time; hence, in these cases there is not a node that is significantly better than the others as the next hop. The general trend is a high variability in the number of selected next hops (comparing day and night and different nodes) and a considerable number of them selected with very low probability, especially during the day.

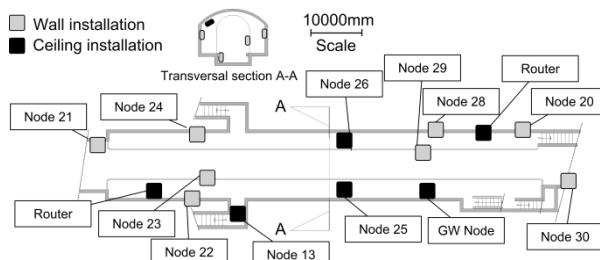

Figure 6 - Deployment schematics of a metro station platform

considerations suggest that signal propagation and routing decisions are influenced by the station conditions, which are more dynamic during the day, thus most of the nodes have to rely on more alternative (multi-hop) paths to be able to reach the gateway node.

### Acknowledgment

This work was carried out in SEAM4US (Sustainable energy management for underground stations) project and during the tenure of an ERCIM "Alain Bensoussan" Fellowship Programme. The research leading to these results has received funding from the European Union

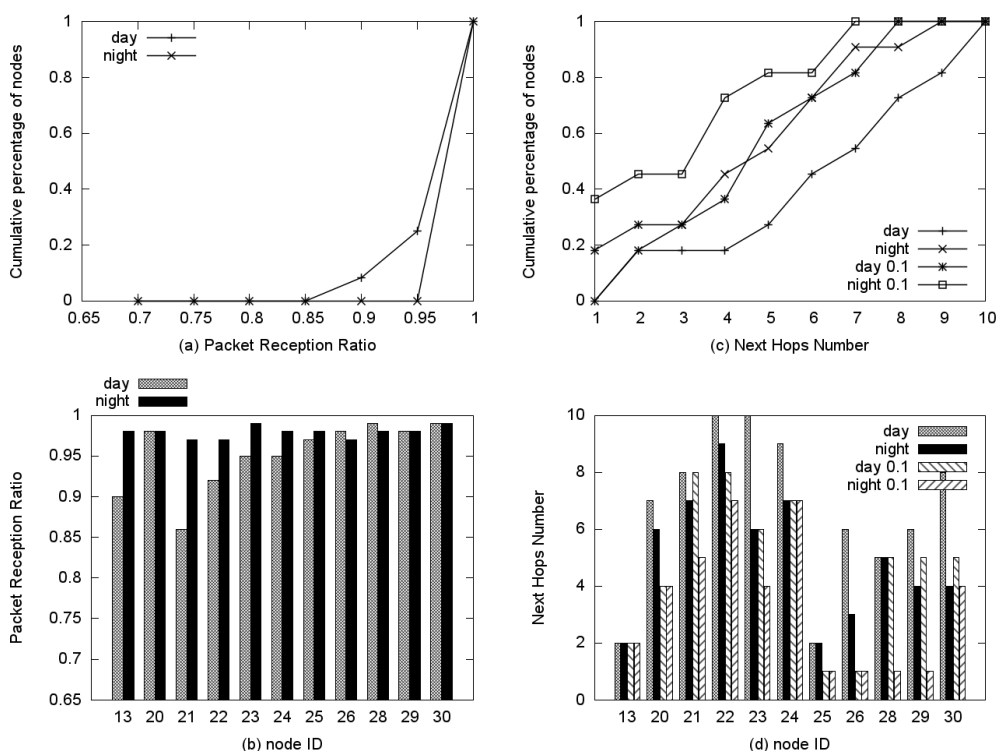

Figure 7 - Packet Reception Ratio (PRR) and Next Hops Number (NHN) count during day and night: CDF (a) and (c), per node values (b) and (d).

Seventh Framework Programme (FP7/2007-2013) under grant agreements n° 285408 and 246016

## 5. Conclusion

In this paper we present the design, implementation and preliminary experimental evaluation of a wireless monitoring system deployed in an underground metro station. The focus is on the description of the developed energy-efficient communication and duty-cycle protocols, whereas a deep analysis of the system performance is out of the scope of this paper. The experimental evaluation shows that wireless communication and routing decisions are influenced by the dynamics of the station, e.g. passengers and trains, exhibiting higher packet loss and usage of more alternative paths when the station is operating. A deeper analysis of the system performance evaluation can surely provide a more complete understanding of characteristics, issues and potentiality of real deployments. Hence, we are now investigating more intensively on the routing approach, especially in terms of packet loss, adaptation to changing conditions and influence of other external factors. As a future work, we would like to improve the routing scheme by including additional metrics in path computation while keeping complexity and overhead low.

## 6. Reference

- [1] SEAM4US project homepage, accessed March 3th 2014, URL: <http://seam4us.eu/>
- [2] R. Ansuini, M. Vaccarini, A. Giretti, and S. Ruffini, "Models for the real-time control of subway stations," in IBPSA'13, Chambéry (FR), 2013, pp.1793-1801
- [3] V. Gallart, S. Felici-Castell, M. Delamo, A. Foster, J.J. Perez, "Evaluation of a real, low cost, urban WSN deployment for accurate environmental monitoring," in IEEE MASS, Wuhan, China, 2011, pp. 634-639
- [4] M. Navarro, T.W. Davis, Y. Liang, X. Liang, "A study of long-term WSN deployment for environmental monitoring," in IEEE PIMRC, 2013, pp. 2093-2097
- [5] C. Oliveira, G. Gonçalves, "Environmental Monitoring Services and wireless sensor networks applied on Urban spaces," in IEEE AQTR, 2010, Vol. 3, pp. 1-6
- [6] T. Torfs et al., "Low power wireless sensor network for building monitoring," IEEE Sensor Journal, vol. 13, no. 3, pp. 909-915, March 2013
- [7] M.V. Ramesh, and V.P. Rangan, "Data reduction and energy sustenance in multisensory networks for landslide monitoring," IEEE Sensor Journal, vol. 14, no. 5, pp. 1555-1563, March 2014
- [8] L. Peralta, and L. PestanaLeão de Brito, "An integrating platform for environmental monitoring in museums based on wireless sensor networks," IJANS, vol. 3, no. 2, pp. 114-124, March 2011
- [9] P. Koskela, M. Valta, T. Frannti, "Energy efficient MAC for wireless sensor networks," Sensors and Transducers Journal, vol. 121, no.10, pp.133 – 143, Oct. 2010
- [10] W. Qianping, L. Liangli, W. Qun, Z. Rui, "Routing algorithm based-on relay nodes in underground WSN," in SWS, , pp.136-140, 26-28 Oct. 2011
- [11] J. Song, H. Gao, Y. Song, "Research on Transceiver System of WSN Based on V-MIMO Underground Coal Mines," in CMC, 2010, vol.2, pp.374-378
- [12] L. Qiong, X. Lihua, "Metro environmental monitoring using wireless sensor networks," in ICCASM, 2010, vol.6, pp.504-508
- [13] J. Nam, H. Kim, B. Min, K. Kim, G. Kim, J. Kim, "Ventilation control of subway station using USN environmental sensor monitoring system," in ICCAS, 2011, pp.305-308
- [14] R. Ansuini, M. Lemma, A. Giretti, "Monitoring System for Energy Management of Buildings. Design of Models and Sensor Networks for Supporting Control Systems," in 39th IAHS World Congress, Milan, pp.565-572, September 2013
- [15] J.S.C. Turner, M.F. Ramli, L.M. Kamarudin, ; A. Zakaria,; et al., "The study of human movement effect on Signal Strength for indoor WSN deployment," in IEEE CWISE, 2013, pp. 30-35
- [16] Contiki OS: 'dak-contikimac-rebase' -head of the malvira-fork, accessed Nov. 5th 2012, URL: <http://git.dev1.org/?p=malvira/contiki-2.x.git;h=refs/heads/dak-contikimac-rebase>
- [17] Dunkels, "The ContikiMAC Radio Duty Cycling Protocol," Swedish Institute of Computer Science, Tech. Rep. T2011:13, Dec. 2011. [Online]: <http://www.sics.se/~adam/dunkels11contikimac.pdf>
- [18] Energizer L91 datasheet, accessed March 3th 2014, URL: <http://data.energizer.com/PDFs/l91.pdf>
- [19] Open source implementation of WSN management API. URL: <http://virtual.vtt.fi/virtual/esna/>
- [20] T. He, et al., "VigilNet: an integrated sensor network system for energy-efficient surveillance", ACM Trans. on Sensor Networks, vol. 2, no. 1, pp. 1-38, Feb. 2006.
- [21] M. Ceriotti, et al., "Monitoring Heritage Buildings with wireless sensor networks: the Torre Aquila deployment", in IPSN, San Francisco, CA, 2009, pp. 277-288