



RESEARCH REPORT

VTT-R-00050-23

Calibration of PBF-LB 316L for Ultrasound Testing

Authors: Yasemin Inc

Confidentiality: Public

Version:



beyond the obvious

Report's title	
Calibration of PBF-LB 316L for Ultrasound Testing	
Customer, contact person, address	Order reference
SAFIR2022 Research Programme	
Project name	Project number/Short name
Additive Manufacturing in Nuclear Power Plants	131753 / AMNPP
Author(s)	Pages
Yasemin Inc	10
Keywords	Report identification code
AM, NDT	VTT-R-00050-23
Summary	
<p>Accurate ultrasonic sound velocity is crucial for the calibration of Ultrasonic Testing (UT) equipment used for material's flaw characterisation and material's properties studies [1], especially for anisotropic additive manufacturing (AM) products. This report communicates the results of a twofold-objective study. First, velocity measurements of the ultrasonic longitudinal waves in different directions on additively manufactured metallic parts using the pulse-echo technique to quantify the effect of anisotropy on the sound velocity, which can be then used for reliable equipment calibration or study of mechanical properties. Second, generation of the Distance-Amplitude Correction (DAC) curves for inspecting the additively manufactured metallic parts.</p>	
Confidentiality	Public
Espoo 30.3.2023	
Written by	Reviewed by
Yasemin Inc, Research Engineer	Mohammed Siddig Senior Scientist
VTT's contact address	
VTT Technical Research Centre of Finland Ltd., PO-Box 1000, FI-02044 VTT	
Distribution (customer and VTT)	
SAFIR2022 stakeholders, pdf VTT, original & pdf	
<p><i>The use of the name of "VTT" in advertising or publishing of a part of this report is only permissible with written authorisation from VTT Technical Research Centre of Finland Ltd.</i></p>	

Approval

VTT TECHNICAL RESEARCH CENTRE OF FINLAND LTD

Date: 30.03.2023

Signature: **Saarenheimo**
Arja 91252369T

Digitally signed by
Saarenheimo Arja 91252369T
Date: 2023.03.30 15:14:35
+03'00'

Name: Arja Saarenheimo

Title: Research Team Leader

CONTENTS

1. Introduction.....	4
2. Ultrasonic wave velocity measurement.....	4
2.1 Experimental setup.....	4
2.2 Results.....	6
3. Distance-Amplitude Correction.....	6
3.1 Experimental setup.....	6
3.2 Results.....	8
4. Conclusions.....	9
5. References.....	10

1. Introduction

Accurate ultrasonic sound velocity is crucial for the calibration of Ultrasonic Testing (UT) equipment used for material's flaw characterisation and material's properties studies [1], especially for anisotropic additive manufacturing (AM) products [2]. Ultrasonic sound velocity is measured using the pulse-echo technique [3], where the Time-of-Flight (TOF) of the ultrasonic beam between two surfaces of a specimen with a known thickness is measured, and sound velocity is then calculated as the ratio of the sound path (specimen thickness) and TOF.

This report communicates the results of a twofold-objective study. First, velocity measurements of the ultrasonic longitudinal waves in different directions on additively manufactured octagonal metallic parts using the pulse-echo technique to quantify the effect of anisotropy on the sound velocity, which can be then used for reliable equipment calibration or study of mechanical properties.

The second objective is to demonstrate the generation of the Distance-Amplitude Correction (DAC) curves [4] for inspecting the additively manufactured metallic parts. The DAC curve compensates for the attenuation of the ultrasonic wave with the increasing distance from the ultrasonic transducer. The wave is attenuated in any material, even if with small attenuation coefficients, which affects the distance sensitivity, and echo signals from the same flaws appear with different sizes at different distances. Therefore, the effects of attenuation should be considered in the inspection with a DAC curve that provides the reference sensitivity level.

For both two objectives, including the octagonal calibration block and seven samples- the additive manufacturing process was Powder Bed Fusion – Laser Beam (PBF-LB).

2. Ultrasonic wave velocity measurement

2.1 Experimental setup

The sound velocity was measured at room temperature using a 3D printed octagonally shaped 316L stainless steel calibration block [5] pictured in Figure 1.

The thickness, which is assumed to be the sound path length, was measured using a digital calliper (Mahr 16EX 150mm) from three different points at the sides of the octagonal sample. The thicknesses varied between 48.16 mm and 48.5 mm, and the mean value of the measurements was used as the thickness value.

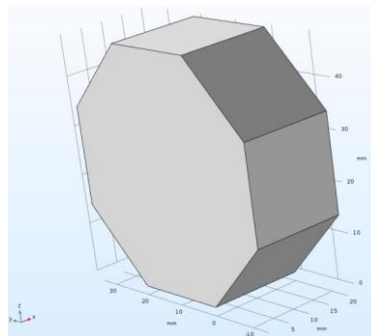

Figure 1. Octagonal sample for sound velocity measurement

The measurements were conducted with the compact A-Scan ultrasonic flaw detector Ge USM Go+ and a 5 MHz contact transducer (Panametrics 5 MHz 0.5B 258564). Water was used as acoustic coupling

between the sample and the probe. The A-scan display (Figure 2) gives the time vs the echo signal amplitude and the time difference between the front and back wall echoes was used to calculate the TOF.

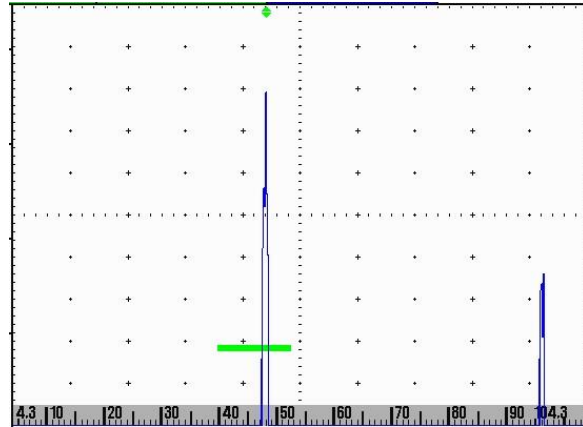

Figure 2. A-Scan screen with two back-wall signals

The ratio between the sound path (measured thickness) and the obtained TOF was used to calculate the sound velocity (Equation 1):

$$sound\ velocity = \frac{sound\ path\ length}{time\ of\ flight} \tag{1}$$

The TOF was measured in three different orientations: vertical, horizontal, and two oblique directions (Figure 3). Fourteen measurements were carried out in each orientation: seven measurements in the direction 1 => 2 and other seven in the opposite direction 2 => 1. For example, for the vertical orientation, seven measurements were taken in the direction V-1 to V-2 and other seven measurements in the direction V-2 to V-1 to make a total of fourteen measurements. The measurements in the horizontal and oblique orientations were performed similarly.

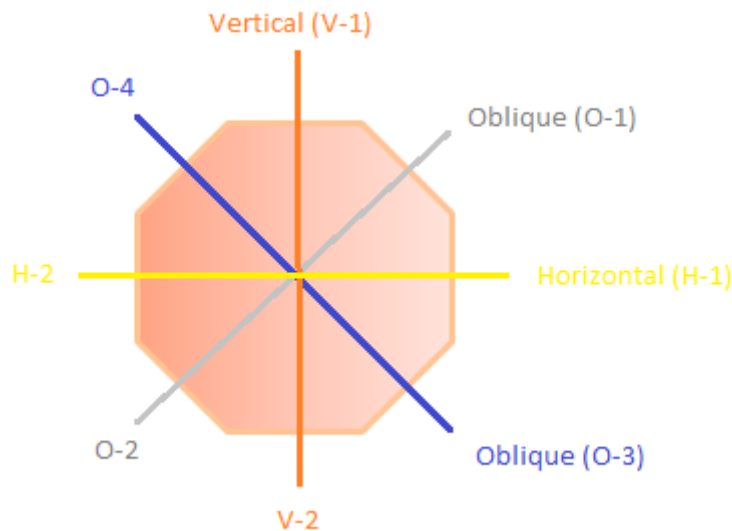

Figure 3. Identification of the measurement directions

2.2 Results

The measured sound velocities were plotted in Figure 4. As clearly can be seen from the measurements, the sound velocities were changing with different orientations. For the entire block, sound velocities were between 5578m/s and 5856m/s, with the faster velocity being in the oblique orientations. The sound velocities in the horizontal orientation were steady, while there were a few irregularities in the vertical and oblique orientations, which are open to future studies.

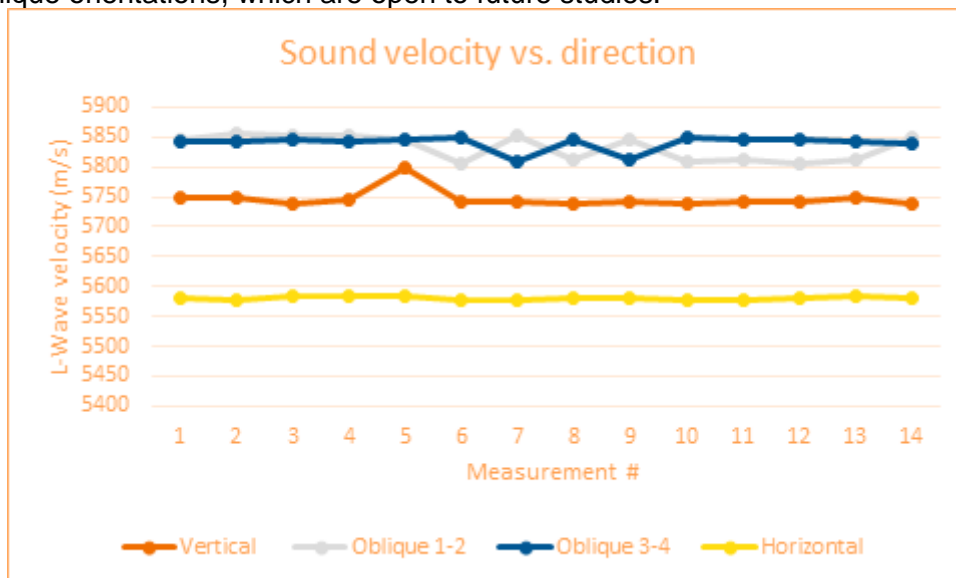

Figure 4. Sound velocities in the identified directions

3. Distance-Amplitude Correction

3.1 Experimental setup

The distance-amplitude curve was generated by measuring the amplitude response of 1 mm and 2 mm diameter drilled holes with known distances from the specimen and then fitting the exponential curve (Figure 5) [5].

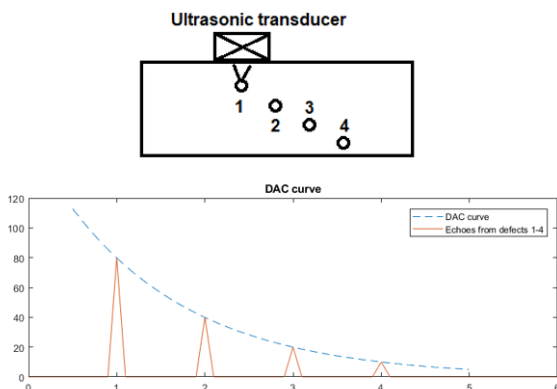

Figure 5. The basic concept of generating the DAC curve

Because of the anisotropic properties of the specimens, seven *Rectangular* DAC blocks with dimensions of 20 mm x 20 mm x 80 mm were manufactured with different orientations to generate the curves. The 1 mm and 2 mm holes were drilled after the blocks were manufactured, with descriptions depicted in Figure 6 and Table 1, and the images of the blocks are shown in Figure 7.

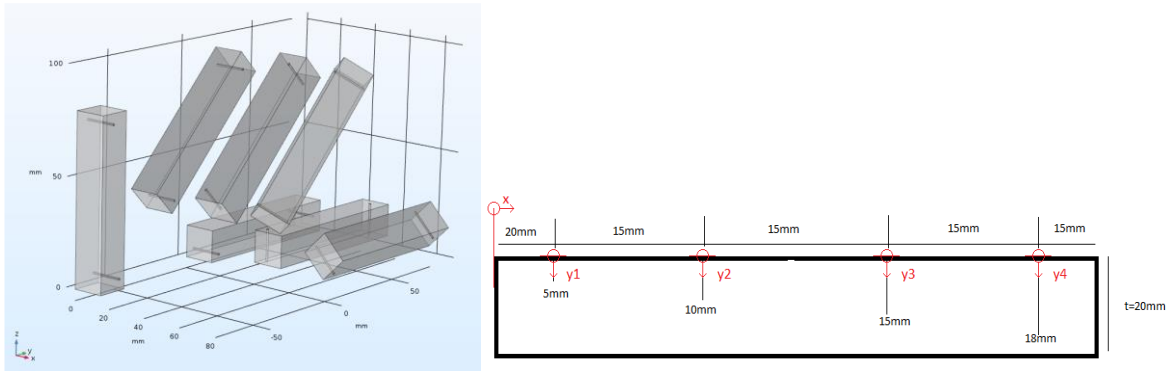

Figure 6. DAC blocks and the locations and diameters of the drilled holes.

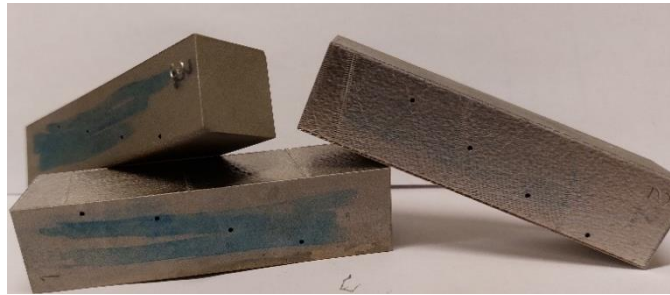

Figure 7. Three manufactured DAC blocks

Table 1. Coordination of the holes in 7 blocks

Block 1 (1mm)	Hole 1	Hole 2	Hole 3	Hole 4	Block 5 (1mm)	Hole 1	Hole 2	Hole 3	Hole 4
X	20,28	35,42	50,42	65,42	X	20,48	35,64	50,55	65,57
Y	4,91	9,59	14,51	17,52	Y	5,01	10,01	14,74	17,70
Block 2 (2mm)	Hole 1	Hole 2	Hole 3	Hole 4	Block 6 (1mm)	Hole 1	Hole 2	Hole 3	Hole 4
X	19,98	35,11	NA	65,16	X	20,34	35,29	50,51	65,68
Y	5,04	10,10	NA	17,82	Y	5,15	9,93	14,74	17,82
Block 3 (1mm)	Hole 1	Hole 2	Hole 3	Hole 4	Block 7 (1mm)	Hole 1	Hole 2	Hole 3	Hole 4
X	20,20	35,47	50,27	65,64	X	20,29	35,20	50,55	65,39
Y	4,94	9,87	14,62	17,76	Y	4,95	9,71	14,64	18,00
Block 4 (2mm)	Hole 1	Hole 2	Hole 3	Hole 4					
X	20,06	35,04	50,27	NA					
Y	4,99	9,84	14,95	NA					

It was first planned to drill 1 mm holes, but the variation in blocks' material properties caused drilling complications that entailed increasing the drill diameter to 2 mm, and yet; some holes could not be drilled (marked with NA in Table 1), and they were not used in the DAC curves plotting.

The UT flaw detector Ge USM Go+ with DAC/TCG features was used for the measurements with four different probes (described in Table 2), and the acoustic coupling medium was water.

Table 2. Specifications of the transducers used for the DAC curves generation

Transducer type	Nominal frequency
0° angle longitudinal contact	5 MHz
0° angle longitudinal contact	4 MHz
45° angle shear contact	4 MHz
60° angle shear contact	4 MHz

3.2 Results

The curves were created with -6dB and -12dB offset using 20mm range for longitudinal waves (L-waves) and 40mm range for shear waves (S-waves). Examples of the obtained curves are shown in Figure 8.

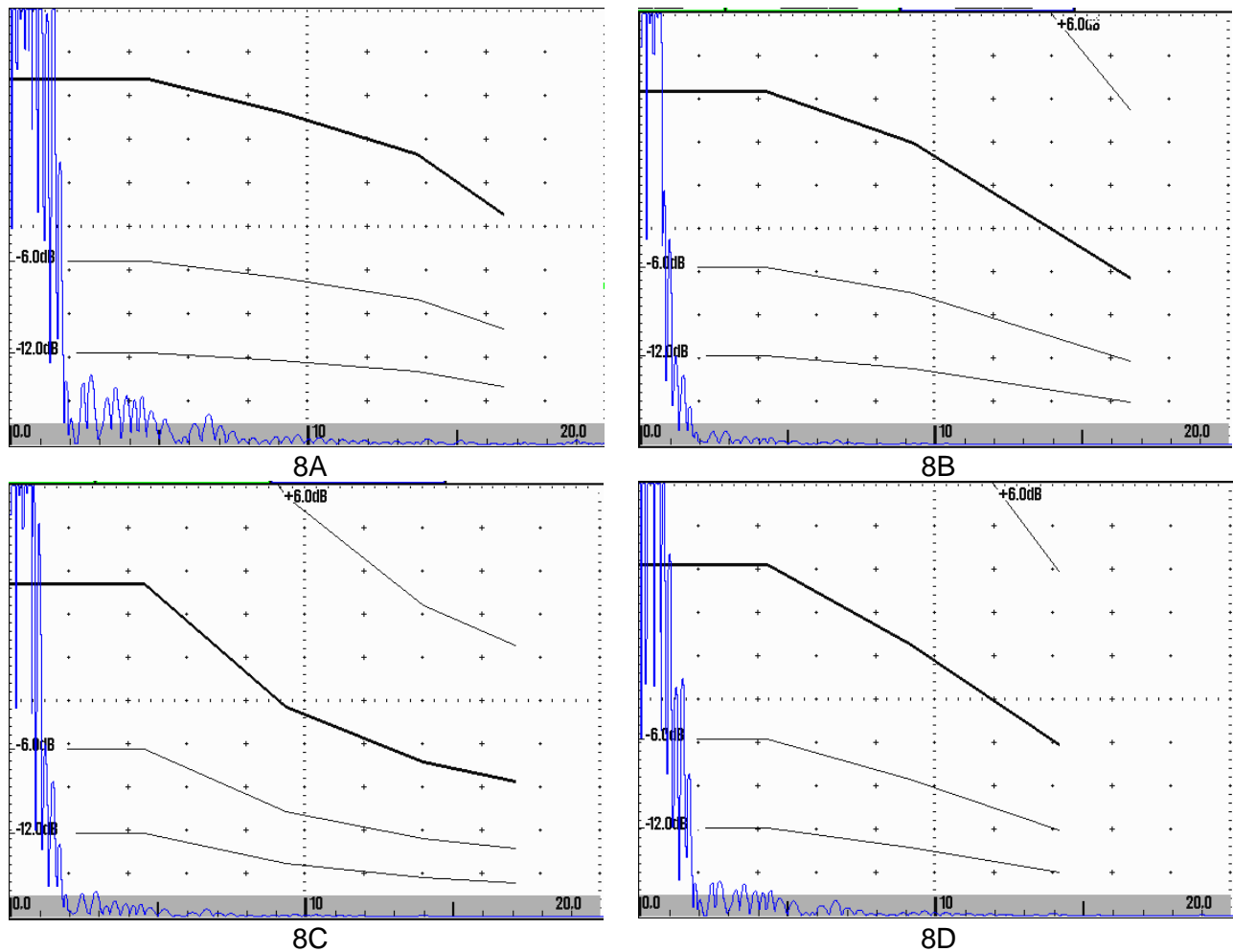

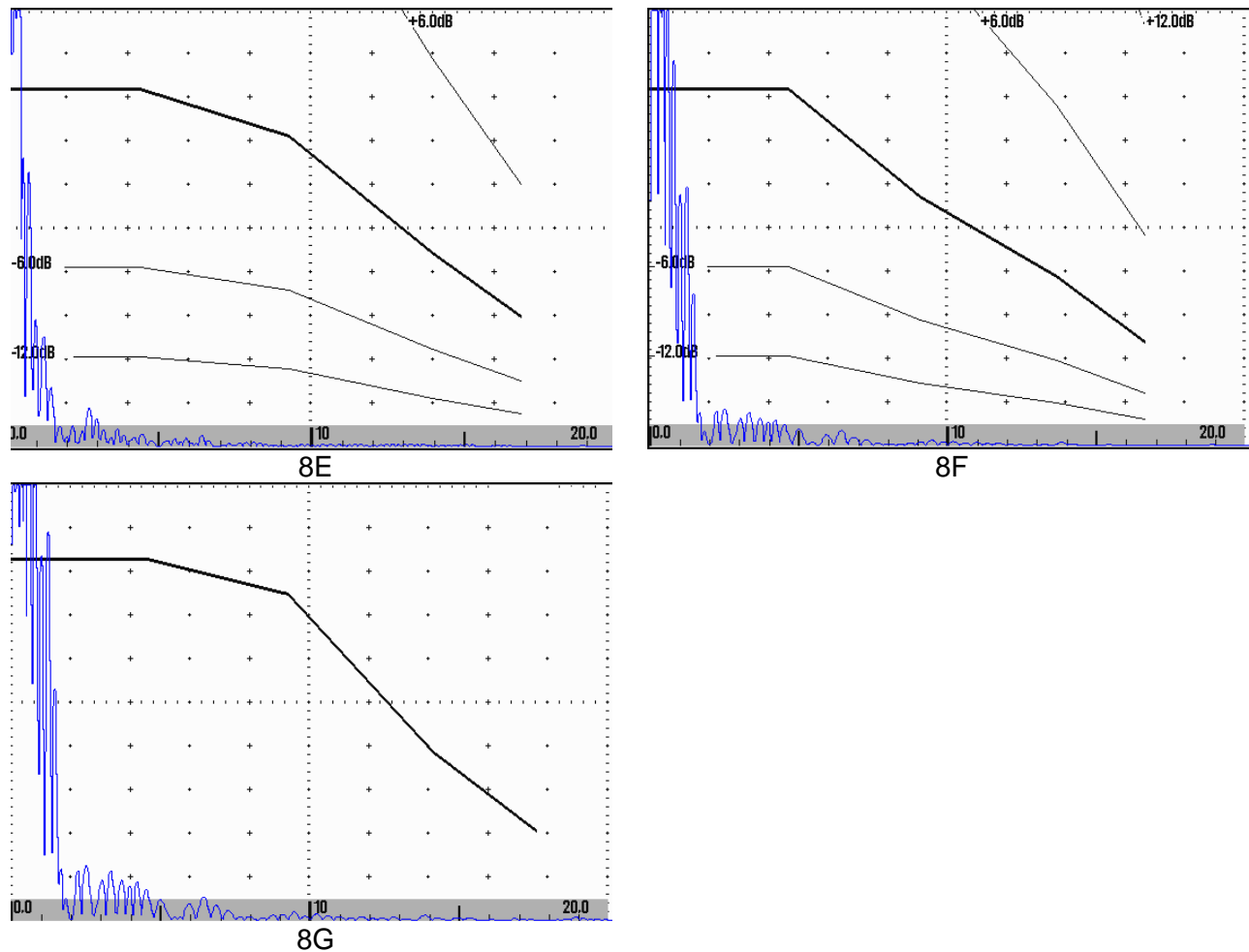

Figure 8. DAC curves generated with 5MHz longitudinal probe: 8A to 8G: Blocks No. 1 to No.7

4. Conclusions

The significance of the AM, also known as 3D printing, is increasingly recognised in the industry. AM produces light and strong components with geometries and shapes otherwise hard to achieve.

Nevertheless, AM products are limited by anisotropy, which poses challenges for Non-Destructive Testing (NDT), especially UT. Therefore, reliable calibration is crucial for UT, where the sound velocity of the material should be accurately measured. Since additively manufactured metal structures are anisotropic, the directional dependency examination must be included in the calibration process.

Moreover, DAC curves provide sensitivity reference to help estimating the relation between defect size and spatial distance, especially in the testing of AM components, where even at small distances, the effect of the attenuation can be observed. It is quite important to have DAC curves for future inspection sensitivity.

This report described the methods used to measure sound velocity to create DAC curves for AM components. The established procedures and obtained results can be used for future studies.

5. References

- [1] Ensminger, D., & Bond, L.J. (2011). Ultrasonics: Fundamentals, Technologies, and Applications, Third Edition (3rd ed.), Chapter 6. CRC Press. <https://doi.org/10.1201/b11173>,
- [2] Javidrad, Hamidreza & Riahi, Mohammad. (2020). Production of Ultrasonic Test Piece by Utilization of Additive Manufacturing Technique. Russian Journal of Nondestructive Testing. 56. 843–852. 10.1134/S106183092010006X.
- [3] Gary L. Workman, Doron Kishoni, Patrick o. Moore. Non-Destructive Testing Handbooks, Third edition, Volume 7; Ultrasonic Testing, ASNT, Chapter 8
- [4] EN 16810:2012, Non-destructive testing — Ultrasonic testing — Part 1: General principles
- [5] VTT-CR-00095-20 _6.7.2020_ TN4: Material Samples Manufacturing and Test Plan