



(12) **EUROPEAN PATENT SPECIFICATION**

(45) Date of publication of patent specification :
12.07.95 Bulletin 95/28

(51) Int. Cl.⁸ : **G01K 7/30, G01K 7/36**

(21) Application number : **90902791.4**

(22) Date of filing : **14.02.90**

(86) International application number :
PCT/FI90/00046

(87) International publication number :
WO 91/12503 22.08.91 Gazette 91/19

(54) **METHOD AND APPARATUS FOR MEASURING THE TEMPERATURE OF AN ELECTRICALLY CONDUCTIVE MATERIAL.**

(43) Date of publication of application :
02.12.92 Bulletin 92/49

(73) Proprietor : **VALTION TEKNILLINEN
TUTKIMUSKESKUS
Vuorimiehentie 5
SF-02150 Espoo 15 (FI)**

(45) Publication of the grant of the patent :
12.07.95 Bulletin 95/28

(72) Inventor : **SEPPÄ, Heikki
VTT/Säh,
Otakaari 7 B
SF-02150 Espoo (FI)
Inventor : **HOLAPPA, Lauri
Tekninen Korkeakoulu
SF-02150 Espoo (FI)****

(84) Designated Contracting States :
DE FR GB IT SE

(56) References cited :
**DE-A- 2 256 887
GB-A- 1 360 940
GB-A- 1 425 013
US-A- 4 095 469**

(74) Representative : **Klunker . Schmitt-Nilson .
Hirsch
Winzererstrasse 106
D-80797 München (DE)**

EP 0 515 356 B1

Note : Within nine months from the publication of the mention of the grant of the European patent, any person may give notice to the European Patent Office of opposition to the European patent granted. Notice of opposition shall be filed in a written reasoned statement. It shall not be deemed to have been filed until the opposition fee has been paid (Art. 99(1) European patent convention).

Description

The present invention relates to a method for measuring the temperature of an electrically conductive material as defined in the introductory part of the independent claim. The invention also relates to an apparatus for implementing the method. The method and apparatus allow the temperature of a hot, solid or molten conductive material to be measured without a contact between the measuring sensor and the object under measurement.

High temperatures of several hundreds or thousands of degrees ($^{\circ}\text{C}$) are mainly measured using a pyrometer or a thermoelement. The former is based on the measurement of the thermal radiation emitted by the object, the latter on the thermoelectric effect.

The radiation pyrometer is a device for contactless temperature measurement. It is capable of measuring the temperature from a fairly long distance from the object. A drawback with the radiation pyrometer e.g. in measurements in the metallurgic industry is the fact that the emissivity of the radiating object depends, in addition to its temperature, also on the radiating material. Therefore, e.g. in the measurement of the temperature of a metal surface, an oxidic recement layer on the surface or a layer of slag on the surface of molten metal may cause significant errors that are difficult to compensate. Similarly, smoke, dust, water vapour etc. cause errors.

The thermoelement is commonly used especially for measuring the temperature of molten metals. This device is used for direct measurement, i.e. the thermo-element is sunk into the object under measurement. The problem is the aggressivity of the circumstances. The sensors used for the measurements are generally of a disposable design and the measurements therefore relate to specific points in the objects. For continuous measurements, it is necessary to use protective tubes, and these retard the transmission of heat, increasing the measuring time lag of the element.

For practical reasons, the thermoelement is difficult to use for measuring the temperature of moving hot objects, e.g. casting or rolling blooms. Therefore, thermoelements attached to the object surface have only been used for research purposes.

It is known that the noise in a thermally balanced electric circuit is directly proportional to the temperature. A general formulation of this law is given in the dissipation theorem, which, when applied to an electric resistance, yields the so-called Nyquist theorem. A device for measuring noise temperature based on this theorem has been constructed. Using this device, the temperature can be realized by using the Boltzmann constant. This principle has been employed for accurate measurements of both low and very high temperatures. In these measurements, the noise is measured from a resistor thermally anchored on the object under measurement. However, the use of this method and device for temperature measurements on hot and particularly moving objects is prevented by the fact that the connecting leads, contacts and the resistor itself are destroyed in high temperatures.

The object of the present invention is to produce a new and improved method and apparatus for measuring the temperature of electrically conductive materials, allowing contactless measurement of the temperature of a body or an object. As for the features characteristic of the invention, reference is made to claim 1 regarding the method, and to claim 8 regarding the apparatus.

The method of the invention is based on the measurement of thermal noise using a resonant circuit without contact with the material under measurement, especially a hot object. In this method, the fluctuation of the magnetic field generated by the random motion of the charge carriers in a metal or other conductive material is measured from a distance from the surface of the material.

The method and apparatus of the invention have the following advantages. The measurement can be performed without contact with the object under measurement. Insulating materials, e.g. air, dust, water vapour and other impurities, will not disturb the measurement significantly. Therefore, the method and the apparatus are especially applicable in industrial measurements, e.g. for the measurement of the temperature of hot casting and rolling blooms. Continuous temperature measurement on moving blooms is also possible. The method also permits the measurement of the temperature of molten metals through an insulating layer of facing material. In closely controlled laboratory conditions, the measurement can be performed with a very high accuracy, so that the method can be used to obtain reference temperatures for the calibration of thermoelements or pyrometers.

In the following, the invention is described in detail by referring to the appended drawings, in which

Fig. 1 shows a block diagram representing an embodiment of the apparatus of the invention;

Fig. 2 represents the noise model of the apparatus of fig. 1;

Fig. 3 shows a perspective view of an embodiment of the apparatus of the invention, partially sectioned;

Fig. 4 shows a block diagram representing another embodiment of the apparatus of the invention together with a measuring unit;

Fig. 5 illustrates the results obtained with the apparatus of the invention in experimental measurements on a steel object.

On the basis of the Nyquist theorem, an electric resistor in a state of thermal balance relative to its environment can supply a noise energy of $k_B T$ per band unit into a resistor at the absolute zero temperature. This applies to low frequencies only, because at high frequencies the thermal energy is discharged into the environment in the form of quanta and the power transfer per band unit becomes frequency-dependent. This phenomenon only occurs at very high frequencies, so that, as far as the method and apparatus of the invention are concerned, the power is evenly distributed over different frequencies. Put simply, the Nyquist theorem means that every electric loss is associated with a thermal noise voltage, the magnitude of which depends on the temperature T , the magnitude of the resistance R and the width B_N of the noise band associated with the measurement. Correspondingly, the generation of the noise can be described as an equivalent current generator connected in parallel with the resistance. In other words

$$\langle e_n^2 \rangle = 4k_B T B_N R \quad (1)$$

$$\langle i_n^2 \rangle = 4k_B T B_N / R \quad (2)$$

where k_B is the Boltzmann constant (1.38×10^{-23} W/K). When the energy associated with the quantum hf (h being the Planck constant and f the quantum frequency) approaches the thermal energy $k_B T$, equations (1) and (2) are no longer valid.

In the apparatus of the invention in figs. 1 and 2, the losses of the object 1 under measurement are applied to the input of the amplifier 2 through a partially open resonant circuit 3. In this case, the resonant circuit 3 uses a coil 4. The inductance of the resonant circuit is L_K , and its wasteful resistances are reduced to a parallel resistance R_K and a corresponding noise current generator i_K . The parallel resistance R_K represents the equivalent losses of the object 1 under measurement in the resonant circuit 3, and i_K the current noise resulting from the losses. Since the conductive object 1 also influences the distribution of the external field, the resonant circuit inductance L depends on the distance s between the coil 4 and the object 1. By using static protectors the inductance of the coil 4 can be regarded as only changing, consisting of a constant part L_K , and the change in the resonant frequency f_o (ω_o) is represented by a variable inductance L_x . The amplifier noise in fig. 2 is represented by current and voltage noise generators i_{fet} and e_{fet} , respectively, connected to the output. The load capacity of the amplifier is represented by a resistance R_f . The temperatures T_x , T_K and T_f represent the temperature of the object under measurement, the coil noise temperature and the amplifier noise temperature, respectively. All capacitances of the circuit are included in the capacitor C , which is assumed to be independent of the distance s between the object 1 and the sensor 5, which in its simplest form consists of a coil 4 and an amplifier 5. It is to be noted that the effects of other losses in the coil 4 have not been considered in the model.

After the amplifier 2, the noise can be detected by means of a suitable detector or measuring unit 6 either directly or by mixing the noise with low frequencies and detecting it by means of a suitable detector circuit.

In an embodiment of the method and apparatus of the invention, the noise is mixed down with a frequency corresponding to the resonant frequency $\omega_o = 1/(LC)$ of the resonant circuit 3. Fig. 4 illustrates such an apparatus. The measurement unit 6, which corresponds to the detector unit 6 in fig. 1, comprises a high-pass filter 7, a voltage-controlled oscillator 8, two mixers 9 and 10, high-pass filters 11 and 12, an adder 13, a r.m.s converter 14, a voltage amplifier 15 and current amplifiers or integrators 16 and 17. In addition, the sensor 5 is provided with a summing amplifier 18 and, if required, a coupling capacitor 19.

In the measurement circuit 6, high-pass filter 7 is connected to mixers 9 and 10. The output terminals 8a and 8b of the voltage-controlled oscillator 8, providing cosine and sine signals respectively, are connected to mixers 10 and 9, respectively. The outputs of the mixers 9, 10 are connected to high-pass filters 11, 12, and the outputs of these are connected to the inputs of the adder 13, whose output is connected to the r.m.s converter 14, whose output provides the measurement signal U_{rms} . Output 8b of the voltage-controlled oscillator 8 is connected via amplifier 15 to the second input 18b of the summing amplifier 18. Output 8a of the voltage-controlled oscillator 8 is connected via the coupling capacitor 19 to the input of the amplifier 2 in the sensor 5. The output of amplifier 2 is connected to the first input 18a of the summing amplifier 18. The output of mixer 9 is connected via current amplifier 16 to the second input of amplifier 15, allowing control of the gain. The output of mixer 10 is connected via current amplifier 17 to the input of the voltage-controlled oscillator 8.

In the apparatus illustrated by fig. 4, the measured noise is mixed down with a frequency corresponding to the resonant frequency $\omega_o = 2\pi f_o$ of the resonant circuit 3. Due to interference, the mixed signal has to be filtered with a high-pass filter 7 with a response of $H_m(j\omega)$. Taking the resonant circuit response and the filter 11,12 after the mixer 9,10 into account, the variance of the output voltage can be expressed as

$$\langle U_{\Sigma}^2 \rangle = \frac{2k_B T_e R}{\pi \omega_0} \int_0^{\infty} \left[\left[1 + \frac{\omega^2}{\omega_0^2} \left[1 - \left(\frac{\omega}{\omega_0} \right)^2 \right]^{-2} + \frac{RT_f}{R_{fo} T_e} \right] \left| H_m(j(\omega - \omega_0)) \right|^2 \right] \omega d\omega \quad (3)$$

where the equivalent temperature T_e of the resonant circuit can be expressed using the component temperatures as follows:

$$T_e = R \left(\frac{T_x}{R_x} + \frac{T_k}{R_k} + \frac{1}{2} \frac{T_f}{R_{fo}} \right) \quad (4)$$

The load resistance R of the resonant circuit is obtained from the equation

$$R^{-1} = (1/R_x + 1/R_k + 1/R_f) \quad (5)$$

In equation (3), ω_0 is the natural frequency R/L of the coil. The noise temperature of the amplifier is T_f for an optimal input impedance R_{fo} . Both T_f and R_{fo} are constants characteristic of the amplifier.

When the resonant frequency ω_0 and total impedance R of the resonant circuit 3 are measured, the temperature T_x of the object 1 can be determined unambiguously from equations (3) - (5).

If the coupling to the object 1 is very good $R \approx R_x$, then $T_e \approx T_x$. If it is additionally assumed that the amplifier has a low noise temperature, i.e. $T_f \ll T_x$, and that the bandwidth of the high-pass filter 11,12 after the mixer 9,10 is clearly larger than that of the resonant circuit 3, then equation (3) will be reduced to the following simple form

$$\langle U_{\Sigma}^2 \rangle = A^2 K_B T_x / C \quad (6)$$

where A is the overall gain before detection and C is the capacitance of the resonant circuit. It can be shown that better results are achieved if a filter bandwidth $H_m(j\omega)$ close to the resonant circuit bandwidth is selected, which means in practice that it is necessary to measure the impedance R and resonant frequency ω_0 of the resonant circuit and to calculate T_x on the basis of these results.

The essential point about the equations presented above is that the detected voltage $\langle U^2 \rangle$ is an unambiguous function $\langle U_{\Sigma}^2 \rangle = f(T_x, R, \omega_0)$ of the object temperature T_x and the loaded impedance R and resonant frequency ω_0 of the coil 4; in other words, object temperature $T_x = g(\langle U_{\Sigma}^2 \rangle, R, \omega_0)$. Correction can be effected either by using equations (3) and (5) or by measuring the output voltage for different temperatures and from different distances and applying the results to a suitable mathematical model.

The object temperature T_x is determined by measuring the variance of the amplified voltage. The variance (inaccuracy of the temperature measurement) of the measured variance σ^2 depends on the measuring time τ and the equivalent noise bandwidth B_e in accordance with the following equation:

$$\text{Var} [\sigma] = \frac{\sigma^2}{B_e \tau} \quad (7)$$

Thus, the relative resolution of the temperature measurement is $\varepsilon = \Delta T/T = (B_e \tau)^{-1/2}$. If the resonant circuit is tuned to a frequency of about 1 MHz, then it is possible to achieve a 100 kHz noise band, so that a 10-second measuring time leads to a resolution of 10^{-3} . The final impedance is determined from the inaccuracy of the impedance measurement, the changes in the noise temperatures of the amplifier and the open coil and from possible interference.

In the apparatus shown in fig. 4, the resonant circuit 3 receives a current via capacitance 19 from output 8a of the voltage-controlled oscillator 8, and a voltage from output 8b via the variable amplifier 15. When the resonant circuit is purely real, the output signal of the summing amplifier 18 has a phase shift of 90° relative to the cosine signal at the oscillator output 8a, and thus the phase detector 10 output becomes zero and the output of the integrator 17 controlling the voltage-controlled oscillator remains unchanged. If the voltage induced in the resonant circuit by the current supplied through output 8a of the voltage-controlled oscillator does not cancel the voltage added to it in the summing amplifier 18, then the output of phase detector 9 will not become zero either, and thus the output of the integrator 16 controlling the gain of amplifier 15 will change until balance is reached. The outputs of both integrators 16, 17 will only become zero when the resonant circuit 3 is fed with a resonant-frequency signal and if the voltage fed into amplifier 18 cancels the voltage obtained from the resonant circuit. Thus, the output of integrator 16 becomes proportional to the real part R of the resonant-circuit impedance during resonance, whereas the output of integrator 15 becomes directly proportional to the resonant frequency ω_0 . After the mixers, the signals associated with the measurement of the impedance R and resonant frequency ω_0 have a low frequency and they have been filtered by the high-pass filters 11 and 12. The noise signals obtained after these filters from both mixers are proportional to the temperature T_x of the object under measurement. The signals are summed by the summing amplifier 13, and the root-mean-square value U_{rms} of the noise is detected by the r.m.s. converter 14.

If necessary, the measuring unit 6 can be provided with one or more absorbing circuits tuned to radio trans-

mitter frequencies close to the resonant frequency. In this way it is possible to avoid the interference caused by these radio stations.

The detected voltage U obtained from the measuring unit 6 can be transferred via an A/D converter to a data processing unit, such as a microcomputer, and used e.g. for process control or supervision.

5 Fig. 3 illustrates an embodiment of the apparatus of the invention, especially the sensor 5, in perspective and partly sectioned. The sensor 5 comprises a coil 4, in this case a winding 3b provided with a ferrite core 3a and fitted inside a frame 3c made of a suitable material, e.g. teflon. The coil 4 is placed at distance s from the material whose temperature T_x is to be measured, as described above. Moreover, the sensor comprises a preamplifier 2 and possibly a mixer amplifier 18 (fig. 4). The preamplifier 2 is built on a circuit board 2a placed in the immediate vicinity of the coil 4. The sensor is mounted inside a static screening, in this case a frame 20 made of a conductive material, such as copper.

The frame 20 is provided with a cooling means 21, which preferably consists of a tubular element wound in a spiral around that end of the frame 20 where the coil 3 is located. A suitable coolant is circulated through the cooling means during measurement.

15 The frame 20 is provided with a shield plate 22 or equivalent placed between the coil 4 and the material under measurement. The shield is made of a heat-resistant and neutral material, e.g. sapphire. In principle, the coil 4 of the sensor 5 is so designed as to make it as insensitive as possible to homogeneous magnetic fields, so that it will only sense the magnetic field fluctuations occurring on the surface of the object under measurement.

20 Fig. 5 shows a graph representing the output U_o of the r.m.s. converter 14 when measuring the temperature of a steel object being heated. The left-hand vertical axis of the graph represents the square $\langle U_o^2 \rangle$ of the r.m.s. value of the noise voltage, representing the measured temperature (K) in accordance with formula (3). The right-hand vertical axis represents the impedance of the coil 4 at the resonant frequency. The horizontal axis represents the temperature (K) of the steel object. The results presented have been normalized by multiplying them with a constant. The r.m.s. value of the noise is linearly dependent on the temperature of the steel object. Therefore, the temperature has been obtained in these measurements by using the formula $T_x = U_o^2/R + B$, where A and B are constants. It can be concluded from the measurement results that the square $\langle U_o^2 \rangle$ of the r.m.s. value of the noise voltage follows the surface temperature T_x of steel quite well. The accuracy of the apparatus can be further improved by increasing the measuring bandwidth, which can be achieved by increasing the resonant frequency. At high frequencies, the amplifier noise temperature can be reduced by cooling the preamplifier as well.

The apparatus of the invention for measuring surface temperatures can be so realized that the measuring accuracy is below $\pm 3K$. A very high accuracy will be achieved by replacing the copper winding of the coil 4 with a superconductor winding, preferably made of ceramic materials. Superconductor windings made of ceramic materials are already usable at the temperature ($+77^\circ K$) of liquid nitrogen.

35 In the above description, the reactance in the resonant circuit 3 consists of an inductance, but it is obvious that this can as well be replaced with a capacitance. In this case, the impedance of the object under measurement is adapted to a level suited for a low-noise preamplifier by means of a capacitance tuned into resonance, e.g. a capacitor, instead of an inductance, e.g. a coil. The measurement is performed fully analogously with the method described above.

40 In the above, the invention has been described by referring to one of its preferred embodiments, but it is obvious that it can be varied in many ways within the scope of the idea of the invention as defined in the following claims.

45

Claims

1. Method for measuring the temperature of an electrically conductive material, based on the measurement of the thermal noise of the material, **characterized** in that the fluctuation of the magnetic field generated by the random motion of the charge carriers in the conductive material is measured using a resonant circuit (3) without contact with the material (1) under measurement.
2. Method according to claim 1, **characterized** in that the measured high-frequency noise is mixed down with low frequencies and detected.
- 55 3. Method according to claim 2, **characterized** in that the mixing is performed at the frequency of the resonant circuit (3).

4. Method according to claim 2 or 3, **characterized** in that the mixed noise signal ($\langle U_o^2 \rangle$) is detected, the resonant frequency (ω_o) and resistance (R) of the resonant circuit (3) are measured and the temperature (T_x) of the object under measurement is calculated from these results.
- 5 5. Method according to claim 4, **characterized** in that the resistance (R) of the resonant circuit (3) is measured by supplying the circuit with a current (I) and a voltage (U) of inverted phase relative to the current, that the frequency and the current amplitude are so adjusted that the signals generated by the current and voltage will cancel each other, so that in the balanced state the resonant frequency (ω_o) is obtained directly from the frequency and the voltage/current ratio (U/I) is directly proportional to the resistance (R)
- 10 of the resonant circuit (3).
6. Method according to claim 3 or 4, **characterized** in that, after the mixing, in order to remove the lower frequencies so as to eliminate interference, the signal is filtered using a filtering bandwidth at least roughly corresponding to the band-width of the resonant circuit (3).
- 15 7. Apparatus for measuring the temperature of an electrically conductive material, the temperature being determined from low-frequency thermal noise measured by the apparatus, **characterized** in that the apparatus comprises
- a sensor (5) provided with a resonant circuit (3), the reactance element of which is placed at a distance (s) from the material (1) whose temperature is to be measured;
 - a preamplifier (2);
- 20 said sensor (5) being mounted inside a frame (20) made of a conductive material, such as copper.
8. Apparatus according to claim 7, **characterized** in that the frame is provided with a cooling means (21).
- 25 9. Apparatus according to claim 7 or 8, **characterized** in that the frame (20) is provided with a shield plate (22) or equivalent placed between the reactance element and the material under measurement, the shield being made of a heat-resistant, neutral material, e.g. sapphire.
10. Apparatus according to claim 7, **characterized** in that the reactance element is a coil (3) consisting of a superconductor winding, preferably made of a ceramic superconductor.
- 30 11. Apparatus according to any one of the preceding claims, **characterized** in that the apparatus additionally comprises a measuring unit (6) including at least a mixer (9, 10) and a detector circuit (14), by means of which the measured noise is mixed down with low frequencies.
- 35 12. Apparatus according to claim 11, **characterized** in that the apparatus additionally comprises a summing amplifier (18) fitted in the sensor (5), and in the measuring unit (6) a high-pass filter (7), a voltage-controlled oscillator (8) with outputs (8a, 8b) for cosine and sine signals, two mixers (8, 9), high-pass filters (11, 12), an adder (13), a r.m.s converter (14), a voltage amplifier (15) and two integrators (16, 17), said high-pass filter (7) being connected to the mixers (9, 10), the outputs (8a, 8b) of the voltage-controlled oscillator (8) to the mixers (9, 10) respectively, the outputs of the mixers (9, 10) to the high-pass filters (11, 12) and the outputs of the high-pass filters (11, 12) to the inputs of the adder (13), the output of which is connected to the r.m.s. converter, whose output provides a measurement signal (U_{rms}) proportional to the temperature of the object under measurement, and in which apparatus the output (8b) of the voltage-controlled oscillator (8) is connected via amplifier (15) to the second input (18b) of the summing amplifier (18), the output (8a) of the voltage-controlled oscillator (8) is connected (19) to the input of the amplifier (2) in the sensor (5) and the output of amplifier (2) is connected to the first input (18a) of the summing amplifier (18), and in which the output of mixer (9) is connected via current amplifier (16) to the second input of amplifier (15) and the output of mixer (10) is connected via current amplifier (17) to the input of the voltage-controlled oscillator (8).
- 40
- 45
- 50

Patentansprüche

- 55 1. Verfahren zum Messen der Temperatur eines elektrisch leitenden Materials auf der Grundlage der Messung des thermischen Rauschens des Materials, dadurch gekennzeichnet, daß die Fluktuation des durch die Zufallsbewegung der Ladungsträger in dem leitenden Material erzeugten magnetischen Feldes unter Verwendung einer Resonanzschaltung (3) ohne

Berührung mit dem auszumessenden Material (1) gemessen wird.

2. Verfahren nach Anspruch 1,
dadurch gekennzeichnet, daß das gemessene hochfrequente Rauschen mit niedrigen Frequenzen her-
5 untergemischt und demoduliert wird.
3. Verfahren nach Anspruch 2,
dadurch gekennzeichnet, daß das Mischen bei der Frequenz der Resonanzschaltung (3) vorgenommen
wird.
- 10 4. Verfahren nach Anspruch 2 oder 3,
dadurch gekennzeichnet, daß das gemischte Rauschsignal ($\langle U_o^2 \rangle$) demoduliert, die Resonanzfrequenz
(ω_0) und der Widerstand (R) der Resonanzschaltung (3) gemessen und die Temperatur (Tx) des Meßob-
jekts aus diesen Ergebnissen berechnet wird.
- 15 5. Verfahren nach Anspruch 4,
dadurch gekennzeichnet, daß der Widerstand (R) der Resonanzschaltung (3) dadurch gemessen wird,
daß in die Schaltung ein Strom (I) eingespeist und an die Schaltung eine Spannung (U) mit bezüglich des
Stroms invertierter Phase angelegt wird, daß die Frequenz und die Stromamplitude derart eingestellt wer-
den, daß die durch den Strom und die Spannung erzeugten Signale einander auslöschen, so daß im ab-
geglichenen Zustand die Resonanzfrequenz (ω_0) direkt aus der Frequenz erhalten wird und das
20 Spannungs-/Strom-Verhältnis (U/I) direkt proportional zum Widerstand (R) der Resonanzschaltung (3)
ist.
- 25 6. Verfahren nach Anspruch 3 oder 4,
dadurch gekennzeichnet, daß nach dem Mischen zur Beseitigung der niedrigeren Frequenzen zwecks Be-
seitigung von Störungen das Signal unter Verwendung einer Filterbandbreite gefiltert wird, die zumindest
grob der Bandbreite der Resonanzschaltung (3) entspricht.
- 30 7. Vorrichtung zum Messen der Temperatur eines elektrisch leitenden Materials, wobei sich die Temperatur
bestimmt aus niederfrequentem thermischen Rauschen, das von der Vorrichtung gemessen wird,
dadurch gekennzeichnet, daß die Vorrichtung aufweist
 - einen Sensor (5), der mit einer Resonanzschaltung (3) ausgestattet ist, deren Reaktanzelement mit
einem Abstand (s) von dem Material (1) angeordnet wird, dessen Temperatur gemessen werden soll;
 - einen Vorverstärker (2);
 wobei der Sensor (5) im Inneren eines Rahmens (20) aus leitendem Material, beispielsweise Kupfer, ge-
35 lagert ist.
8. Vorrichtung nach Anspruch 7,
dadurch gekennzeichnet, daß der Rahmen mit einer Kühleinrichtung (21) ausgestattet ist.
- 40 9. Vorrichtung nach Anspruch 7 oder 8,
dadurch gekennzeichnet, daß der Rahmen (20) mit einer Abschirmplatte (22) oder einem dazu äquiva-
lenten Mittel ausgestattet ist, angeordnet zwischen dem Reaktanzelement und dem auszumessenden
Material, wobei die Abschirmung aus einem hitzebeständigen, neutralen Material, z. B. Saphir, hergestellt
45 ist.
10. Vorrichtung nach Anspruch 7,
dadurch gekennzeichnet, daß das Reaktanzelement eine Spule (3) ist, bestehend aus einer Supraleiter-
Wicklung, die vorzugsweise aus einem Keramik-Supraleiter hergestellt ist.
- 50 11. Vorrichtung nach einem der vorhergehenden Ansprüche,
dadurch gekennzeichnet, daß die Vorrichtung zusätzlich aufweist: eine Meßeinheit (6) mit mindestens ei-
nem Mischer (9, 10) und einer Demodulatorschaltung (14), mit deren Hilfe das gemessene Rauschen mit
niedrigen Frequenzen heruntergemischt wird.
- 55 12. Vorrichtung nach Anspruch 11,
dadurch gekennzeichnet, daß die Vorrichtung zusätzlich aufweist: einen Summierverstärker (18), der in
den Sensor (5) eingebaut ist, und in der Meßeinheit (6) ein Hochpaßfilter (7), einen spannungsgesteuerten

Oszillator (8) mit Ausgängen (8a, 8b) für Kosinus- und Sinussignale, zwei Mischer (9, 10), Hochpaßfilter (11, 12), einen Addierer (13), einen Mittelwertwandler (14), einen Spannungsverstärker (15) und zwei Integratoren (16, 17), von denen das Hochpaßfilter (7) an die Mischer (9, 10) angeschlossen ist, die Ausgänge (8a, 8b) des spannungsgesteuerten Oszillators (8) an die jeweiligen Mischer (9, 10) angeschlossen sind, die Ausgänge der Mischer (9, 10) an die Hochpaßfilter (11, 12) angeschlossen sind, und die Ausgänge der Hochpaßfilter (11, 12) an die Eingänge des Addierers (13) gelegt sind, dessen Ausgang an den Mittelwertwandler angeschlossen ist, dessen Ausgang ein Meßsignal (U_{rms}) liefert, das proportional zu der Temperatur des Meßobjekts ist, und wobei in der Vorrichtung der Ausgang (8b) des spannungsgesteuerten Oszillators (8) über Verstärker (15) an den zweiten Eingang (18b) des Summierverstärkers (2) in dem Sensor (5) angeschlossen ist, und der Ausgang des Verstärkers (2) mit dem ersten Eingang (18a) des Summierverstärkers (18) gekoppelt ist, und wobei der Ausgang des Mixers (9) über einen Stromverstärker (16) an den zweiten Eingang des Verstärkers (15) und der Ausgang des Mixers (10) über einen Stromverstärker (17) an den Eingang des spannungsgesteuerten Oszillators (8) angeschlossen ist.

Revendications

1. Procédé pour mesurer la température d'un matériau électriquement conducteur, basé sur la mesure du bruit thermique du matériau, caractérisé en ce qu'on mesure la fluctuation du champ magnétique engendré par le mouvement désordonné des porteurs de charges dans le matériau conducteur en utilisant un circuit résonant (3) hors de contact avec le matériau (1) à mesurer.
2. Procédé selon la revendication 1, caractérisé en ce que le bruit à haute fréquence mesuré est mixé avec des basses fréquences et détecté.
3. Procédé selon la revendication 2, caractérisé en ce que le mixage est réalisé à la fréquence du circuit résonant (3).
4. Procédé selon l'une des revendications 2 et 3, caractérisé en ce qu'on détecte le signal de bruit mixé ($\langle U_o^2 \rangle$), qu'on mesure la fréquence de résonance (ω_o) et la résistance (R) du circuit résonant (3) et qu'on calcule à partir de ces résultats la température (T_x) de l'objet à mesurer.
5. Procédé selon la revendication 4, caractérisé en ce qu'on mesure la résistance (R) du circuit résonant (3) en fournissant au circuit un courant (I) et une tension (U) ayant une phase inversée par rapport au courant, que la fréquence et l'amplitude du courant sont ajustées de telle sorte que les signaux produits par le courant et la tension s'annulent mutuellement, grâce à quoi à l'état d'équilibre la fréquence de résonance (ω_o) est obtenue directement à partir de la fréquence et le rapport tension/courant (U/I) est directement proportionnel à la résistance (R) du circuit résonant (3).
6. Procédé selon l'une des revendications 3 et 4, caractérisé en ce que, après le mixage, afin de supprimer les basses fréquences de façon à éliminer les interférences, on filtre le signal en utilisant une largeur de bande de filtrage correspondant au moins grossièrement à la largeur de bande du circuit résonant (3).
7. Appareil pour mesurer la température d'un matériau électriquement conducteur, la température étant déterminée à partir du bruit thermique à basse fréquence mesuré par l'appareil, caractérisé en ce que l'appareil comprend :
 - un capteur (5) muni d'un circuit résonant (3) dont l'élément à réactance est placé à une certaine distance (s) du matériau (1) dont la température doit être mesurée;
 - un préamplificateur (2);
 ledit capteur (5) étant monté à l'intérieur d'un châssis (20) réalisé en un matériau conducteur tel que le cuivre.
8. Appareil selon la revendication 7, caractérisé en ce que le châssis est muni de moyens de refroidissement (21).
9. Appareil selon l'une des revendications 7 et 8, caractérisé en ce que le châssis (20) est muni d'une plaque écran (22) ou équivalent placée entre l'élément à réactance et le matériau à mesurer, l'écran étant réalisé en un matériau neutre résistant à la chaleur, par exemple le saphir.

10. Appareil selon la revendication 7, caractérisé en ce que l'élément à réactance est une bobine (3) constituée par un enroulement de supraconducteur, réalisé de préférence en un supraconducteur céramique.
- 5 11. Appareil selon l'une des revendications précédentes, caractérisé en ce que l'appareil comprend en outre une unité de mesure (6) comportant au moins un mélangeur (9, 10) et un circuit détecteur (14), au moyen desquels le bruit mesuré est mixé avec des fréquences basses.
- 10 12. Appareil selon la revendication 11, caractérisé en ce que l'appareil comprend en outre un amplificateur sommateur (18) incorporé dans le capteur (5), et dans l'unité de mesure (6) un filtre passe-haut (7), un oscillateur commandé en tension (8) ayant des sorties (8a, 8b) pour des signaux sinus et cosinus, deux mélangeurs (8, 9), des filtres passe-haut (11, 12), un additionneur (13), un convertisseur de valeurs efficaces (14), un amplificateur de tension (15) et deux intégrateurs (16, 17), ledit filtre passe-haut (7) étant raccordé aux mélangeurs (9, 10), les sorties (8a, 8b) de l'oscillateur commandé en tension (8) aux mélangeurs (9, 10) respectivement, les sorties des mélangeurs (9, 10) aux filtres passe-haut (11, 12) et les sorties des filtres passe-haut (11, 12) aux entrées de l'additionneur (13), dont la sortie est raccordée au convertisseur de valeurs efficaces, la sortie de celui-ci fournissant un signal de mesure (U_{rms}) proportionnel à la température de l'objet à mesurer, et dans lequel appareil la sortie (8b) de l'oscillateur commandé en tension (8) est raccordée par l'intermédiaire de l'amplificateur (15) à la seconde entrée (18b) de l'amplificateur à sommation (18), la sortie (8a) de l'oscillateur commandé en tension (8) est raccordée (19) à l'entrée de l'amplificateur (2) dans le capteur (5) et la sortie de l'amplificateur (2) est raccordée à la première entrée (18a) de l'amplificateur sommateur (18), et dans lequel la sortie du mélangeur (9) est raccordée par l'intermédiaire de l'amplificateur de courant (18) à la seconde entrée de l'amplificateur (15) et la sortie du mélangeur (10) est raccordée par l'intermédiaire de l'amplificateur de courant (17) à l'entrée de l'oscillateur commandé en tension (8).
- 15
- 20
- 25

30

35

40

45

50

55

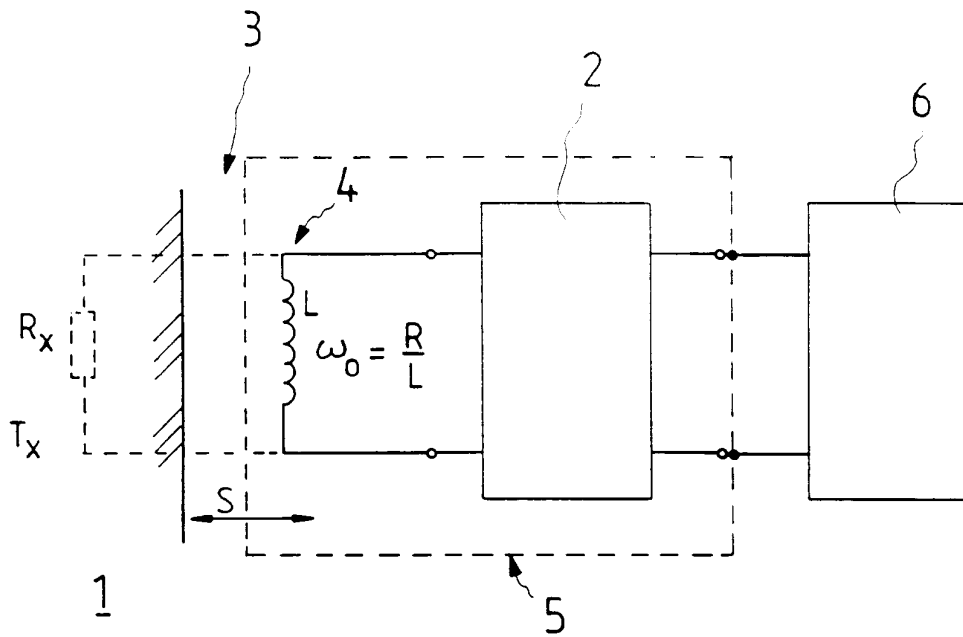

Fig.1

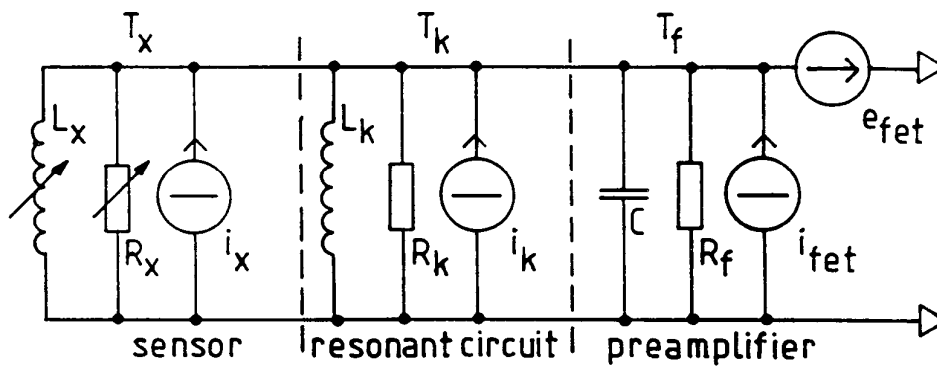

Fig.2

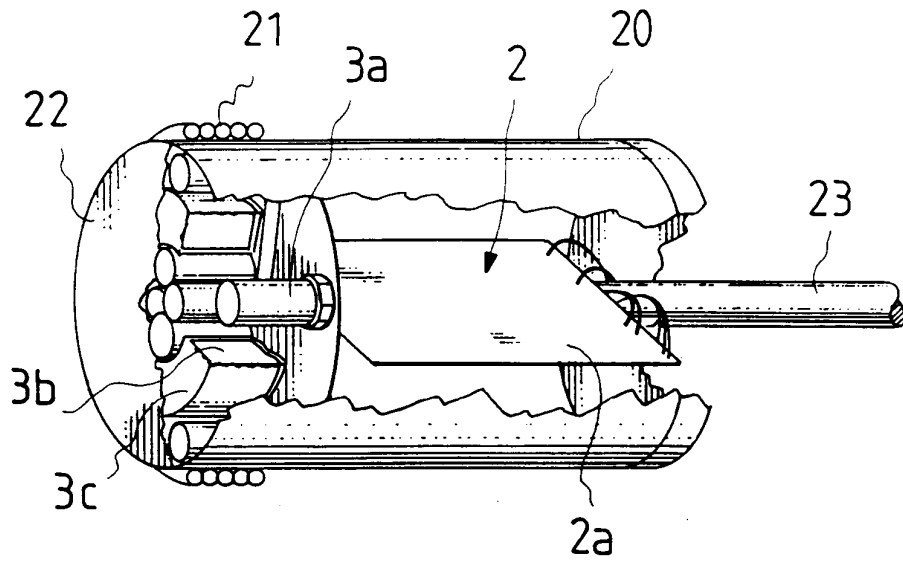

Fig. 3

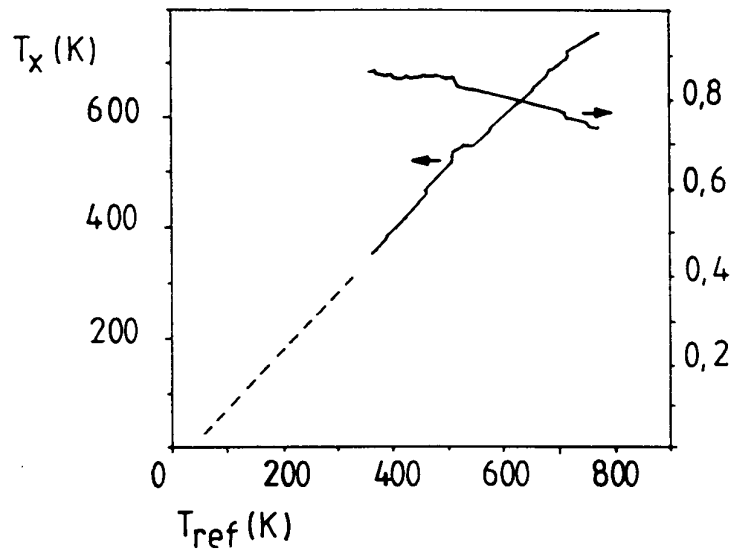

Fig. 5

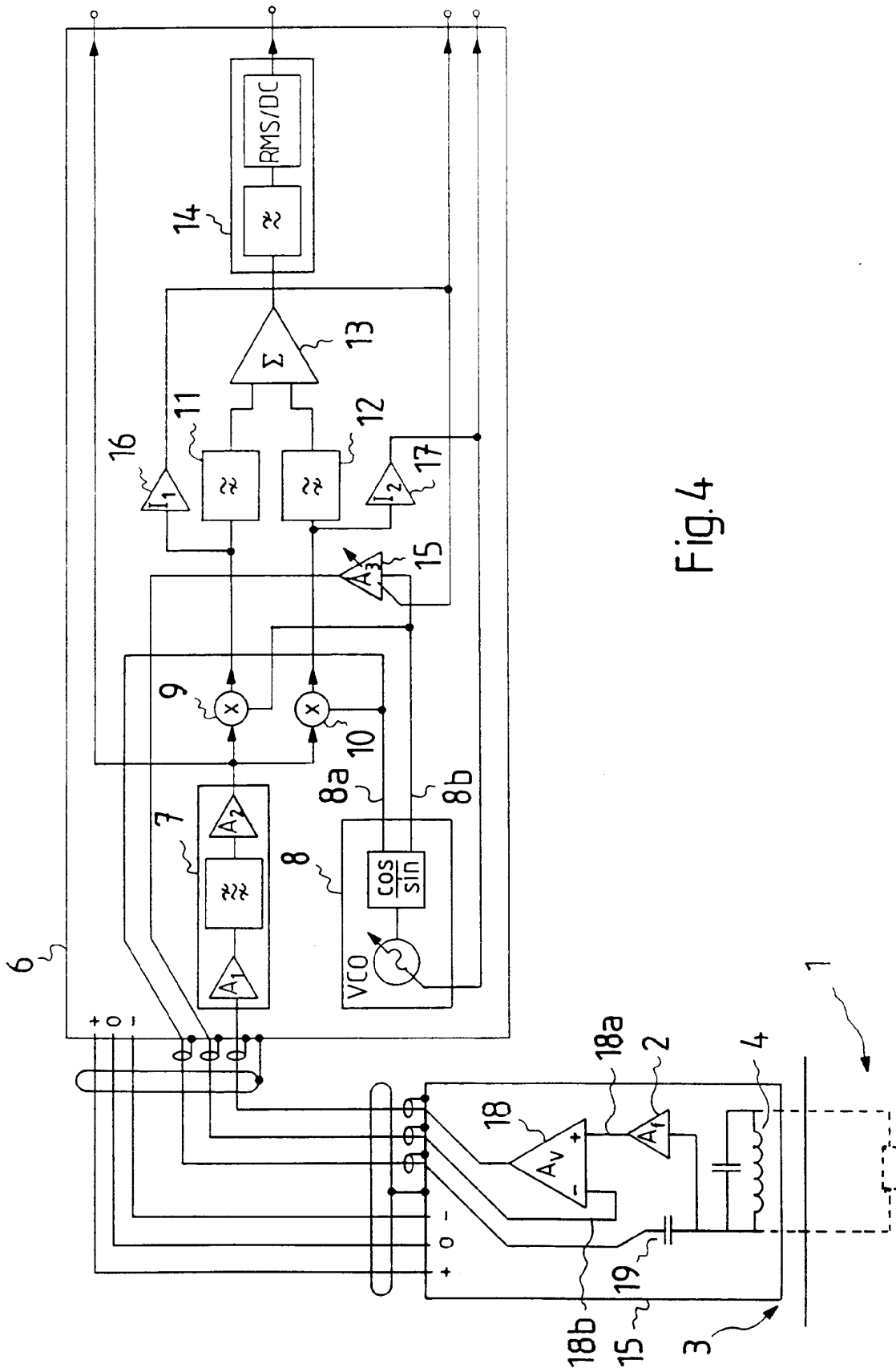

Fig. 4