



Impact of waste-to energy on the demand and supply relationships of recycled fibre

Petri Ristola

Impact of waste-to-energy on the demand and supply relationships of recycled fibre

Petri Ristola

*Doctoral dissertation for the degree of Doctor of Science in Technology
to be presented with due permission of the School of Science for public
examination and debate in Auditorium TU1 at the Aalto University School
of Science (Espoo, Finland) on the 4th of June, 2012, at 12 noon.*

ISBN 978-951-38-7451-3 (soft back ed.)

ISSN 2242-119X (soft back ed.)

ISBN 978-951-38-7452-0 (URL: <http://www.vtt.fi/publications/index.jsp>)

ISSN 2242-1203 (URL: <http://www.vtt.fi/publications/index.jsp>)

Copyright © VTT 2012

JULKAISIJA – UTGIVARE – PUBLISHER

VTT

PL 1000 (Vuorimiehentie 5, Espoo)

02044 VTT

Puh. 020 722 111, faksi 020 722 4374

VTT

PB 1000 (Bergsmansvägen 5, Esbo)

FI-2044 VTT

Tfn. +358 20 722 111, telefax +358 20 722 4374

VTT Technical Research Centre of Finland

P.O. Box 1000 (Vuorimiehentie 5, Espoo)

FI-02044 VTT, Finland

Tel. +358 20 722 111, fax + 358 20 722 4374

Impact of waste-to-energy on the demand and supply relationships of recycled fibre

[Jätteiden energiakäytön vaikutukset kiertokuidun kysyntä- ja tarjontasuhteisiin]
Petri Ristola. Espoo 2012. VTT Science 4. 190 p. + app. 130 p.

Abstract

Today, recycled fibre is globally the most important papermaking raw material in terms of volume. Its collection and use has tripled in absolute terms since 1990 and its market share of all fibres used in papermaking has increased by roughly 1 %-unit per year. Still, globally speaking, about a third of the volume of used paper that could potentially be used for recycling is just disposed of. Thus, recycled fibre can, and is expected to, further increase its market share of papermaking fibres.

There is, however, increasing turmoil in the market for papermaking raw materials as a consequence of the political agenda aimed at mitigating global warming and decreasing the use of fossil fuels. This has already become evident in the European fuel wood market, and there is also growing interest in the efficient utilisation of the fuel component in solid wastes, including the discarded paper that currently remains outside recycling. Today in Europe, just about a third of the solid waste is recovered as energy, mostly at relatively low-efficiency waste incineration facilities.

The paper industry has recently played an active role in these trends, too. Recycled-fibre-based paper mills in Europe have started to employ modern technology for the sole and co-combustion of refuse-derived fuels and process tailings. These units are dimensioned for the energy needs of the paper mills and have been found to be highly effective in cutting the energy bill for recycled-fibre-based papermaking. In continuance of this theme, proposals have been made concerning more advanced concepts that employ fibre separation techniques from different solid waste streams for further utilisation in the manufacturing of paper products, or, for instance, in ethanol conversion. This development underlines the strong technical synergies between recycled-fibre-based papermaking and modern waste-to-energy technologies. At the same time it poses serious questions concerning the expected further increase in the usage of recycled fibre in papermaking.

This dissertation discusses the application of modern waste-to-energy technologies in the paper industry as a means of improving individual paper mills' competitive positions and financial performance. Their impact is found to be clearly significant and therefore the on-going investment activity can be expected to continue. As the use of various solid wastes for fuel potentially interferes with the targeted increase in paper recycling, there emerges a need to analyse the impacts of this development on the recycled fibre markets. This is achieved by developing a quantifiable model for analysing the composite market for various discarded-paper-containing waste flows and by conducting a Delphi study on the supply-

demand behaviour of recycled fibre. The Delphi study utilised a panel of experts to i) gain support and feedback concerning the construction of the composite market model, ii) gain qualitative insight on the likely development scenarios for the recovered paper market, and iii) create a basis for preliminary quantification and testing of the model.

By combining the results of the Delphi study and the composite market model, this study paints a picture of a future scenario for the composite RCF market in Europe in 2020. The main scenario is complemented by a selection of alternative views of the future that stem from the Delphi process. It becomes evident that the times of inexpensive recycled fibre for papermaking are past, and that the energy sector is also developing significant paying capabilities for recycled-fibre-containing waste flows.

Keywords pulp and paper industry, recycled fibre, recovered paper, wastepaper, waste-to-energy, foresight study, Delphi, price theory, constructive research

Jätteiden energiakäytön vaikutukset kiertokuidun kysyntä- ja tarjontasuhteisiin

[Impact of waste-to-energy on the demand and supply relationships of recycled fibre]
Petri Ristola. Espoo 2012. VTT Science 4. 190 s. + liitt. 130 s.

Tiivistelmä

Kiertokuitu on nykyisin määrällisesti mitattuna maailmanlaajuisesti merkittävin paperinvalmistuksen raaka-aine. Sen keräily ja käyttö on tonneissa kolminkertaistunut vuodesta 1990 ja markkinaosuus kaikesta paperiteollisuuden käyttämästä kuidusta on kasvanut vuosittain noin yhdellä prosenttiyksiköllä. Maailmanlaajuisesti tarkasteltuna edelleen noin kolmannes käytöstä poistetusta paperista, joka teoriassa voitaisiin kierrättää, hävitetään. Siten kiertokuitu voi ja sen edelleen myös odotetaan kasvattavan markkinaosuuttaan paperinvalmistuksen kuituraaka-aineiden joukossa.

Yhtäältä ilmastonmuutoksen hillitsemiseen ja toisaalta riippuvuutemme vähentämiseen fossiilisista polttoaineista, tähtäävät poliittiset päätökset ovat aiheuttaneet kasvavaa epävarmuutta paperinvalmistuksen raaka-ainemarkkinoilla. Kehityksen seuraukset ovat jo nähtävissä Euroopan energiapuumarkkinoilla. Myös kiinteisiin jätteisiin ja erityisesti niiden palavan jakeen tehokkaaseen hyödyntämiseen kohdistuu kasvavaa kiinnostusta. Tämä jae sisältää myös kierrätyksen ulkopuolella olevan jätepaperin. Nykyisin Euroopassa, ainoastaan noin kolmannes kiinteistä jätteistä hyödynnetään energiana, siitäkin suurin osa melko heikon hyötysuhteen jätteenpolttolaitoksissa.

Myös paperiteollisuus on viime aikoina ollut aktiivinen tässä kehityksessä. Kiertokuituun perustuvat paperitehtaat ovat ryhtyneet ottamaan käyttöön modernia voimalaitosteknologiaa kierrätyspolttoaineiden ja tuotantojätteiden yhteispoltossa. Nämä yksiköt on tyypillisesti mitoitettu vastaamaan paperitehtaan energiatarpeeseen, ja ne pystyvät tehokkaasti pienentämään kiertokuitupohjaisten paperitehtaiden energiakustannuksia. Tähän liittyen on ehdotettu myös edistyksellisempiä konsepteja, jotka hyödyntävät kuidun erotustekniikoita erilaisista jätevirroista, jolloin jätevirtojen kuituosuus voidaan hyödyntää raaka-aineena paperin tai esimerkiksi etanolin valmistuksessa. Tämä kehityssuunta alleviivaa nykyaikaisen jätteiden energiakäytön ja paperinvalmistuksen synergioita, mutta samanaikaisesti herättää kysymyksen, voiko kiertokuidun markkinaosuus jatkaa odotettua kasvuaan paperinvalmistuksessa.

Väitöskirja tarkastelee nykyaikaisten jätteiden energiakäyttökoneiden käyttöönottoa paperitehtailta keinona parantaa niiden kilpailuasemaa ja taloudellista kannattavuutta. Vaikutuksen todetaan olevan merkittävä, ja siksi nykyisen kehityksen voidaan olettaa jatkuvan. Koska erinäisten kiinteiden jätevirtojen hyödyntäminen polttoaineena saattaa häiritä tavoitteita lisätä paperin kierrätystä, on tarpeen analysoida tämän kehityksen vaikutuksia kiertokuitumarkkinaan. Tämä toteutetaan kehittämällä kvantifioitavissa oleva komposiittimalli, joka yhdistää paitsi keräyspa-

perin myös muut jät-paperia sisältävät jätevirrat yhteen markkinamalliin. Kiertokuidun kysyntä- ja tarjontakäyttäytymisen ymmärtämiseksi tehtiin Delfoi-tutkimus, jossa asiantuntijapaneelin avulla luodaan i) tarvittava tuki ja asiantuntijapalaute koskien mallin rakentamista, ii) kvalitatiivinen näkemys kiertokuitumarkkinan todennäköisistä kehitysskenaarioista ja iii) perusta mallin alustavalle kvantifioinnille ja testaamiselle.

Tutkimuksessa yhdistettiin Delfoi-tutkimuksen tulokset ja markkinan komposiittimalli, ja lopputuloksena on visio kiertokuidun komposiittimarkkinan tilasta Euroopassa vuonna 2020. Pääskenaariota täydennetään joukolla Delfoi-tutkimuksesta johdettavia vaihtoehtoisia skenaarioita. On ilmeistä, että edullisen kiertokuidun aika on ohi ja että myös energiasektorille syntyy merkittävää maksukykyä jätevirroista, jotka sisältävät kiertokuitua.

Avainsanat pulp and paper industry, recycled fibre, recovered paper, wastepaper, waste-to-energy, foresight study, Delphi, price theory, constructive research

Preface

This thesis elaborates the current and likely future impacts of waste-to-energy on supply and demand behaviour of recycled fibre. My interest in the subject has its origins in the work I carried out in Metso during the years 1999–2004, when I was employed full-time in activities aimed at applying modern waste-to-energy technologies in a paper mill environment in a completely new way. In 1998 I had enrolled to the doctoral programme of Department of Industrial Management at Helsinki University of Technology. The logical aim all the way from the beginning was to build a scientific research project that would be supported by my practical work in the field.

Things, however, don't always work as planned and by the end of 2004 I found myself working in totally different projects with little idea how to conclude my studies with a thesis project. Suddenly, at the end of 2008, the global recession provided me a break of 4–6 weeks during which I found the idea and inspiration how to bring everything together. That would mean building a theory to explain consequences of the on-going change in waste-to-energy sector on the recycled fibre market. The project proved time consuming and being carried out during weekends and evenings it pushed the patience of my family, for sure. I am forever grateful for the sacrifices my wife paid to provide me the time and space to work on my thesis.

I want to thank all the members of the Delphi panel for their unselfish contributions in my research project. I would especially like to thank Research Professor Kai Sipilä for his support and advice that are based on truly broad insight of the issues in the European bioenergy and waste sectors. Also Lassi Hietanen and Esa Sipilä helped me a lot by devoting their time in series of interesting discussions and debate on the nature of the markets in question. During our discussions Ilpo Ervasti continued to impress me with the immense amount of valuable and detailed know-how on the European recovered paper market that he masters. Special thanks go to my highly experienced and merited instructors Dr. Markku Karlsson, Magnus Diesen and Dr. Osmo Kuusi. Without the guidance of my supervisor, Professor Eero Eloranta, I would never have managed to produce true scientific research. Particular thanks for highly encouraging reviews go to my preliminary examiners Dr. Jürgen Vehlow from the Karlsruhe Institute of Technology and Dr. Petri Vasara from Poyry Management Consulting Oy.

I also want to thank my dear friend Dr. Rosalind Taylor in Trafelgwyn, Wales. Besides Dr. Karlsson who has obviously mentored me throughout our long friendship, Dr. Taylor has been the one who has not only kindly pushed me to finalise my studies but has also greatly inspired me with the rigour she shows in all that she does.

Also my employer, Metso, and my colleagues in its Paper Mills unit deserve great thanks for their support and the encouraging working atmosphere.

Finally, I would like to thank my family, my beloved wife Suvi, my daughter Peppi and my small sons Topias and Roope. I remain grateful for your support and I wish this work could one day inspire you to become acquainted with Science.

Kerava, January 2012

Petri Ristola

Academic dissertation

Supervisor Univ. Prof., Vice Dean, Dr. Eero Eloranta
School of Science
Aalto University
Espoo, Finland

Reviewers Prof. emeritus, Dr. Jürgen Vehlow
Institute for Technical Chemistry
Karlsruhe Institute of Technology
Eggenstein-Leopoldshafen, Germany

and

Dr. Petri Vasara
Pöyry Management Consulting Oy
Vantaa, Finland

Opponents Univ. Prof., Dr. Ari-Pekka Hameri
Université de Lausanne
Lausanne, Switzerland

and

Prof. emeritus, Dr. Jürgen Vehlow

Contents

Abstract	3
Tiivistelmä	5
Preface	7
Academic dissertation	9
1. Introduction	17
1.1 Background.....	17
1.1.1 Utilisation of recycled fibre in papermaking	21
1.1.2 Waste-to-energy technologies and their utilisation by the paper industry.....	24
1.1.3 Fuel use of biomass and the paper industry.....	25
1.2 Research issue and objectives of the research	27
1.3 Structure of the dissertation	28
1.4 Some important exclusions	29
1.5 Terminology and abbreviations	30
2. Research methodology and design	35
2.1 Potential research strategies.....	35
2.2 Scientific foresight studies and the Delphi method	43
2.2.1 Popular typologies in scientific foresight studies.....	43
2.2.2 The Delphi method	45
2.3 Selected research strategy.....	48
2.4 Research design.....	51
3. Pre-identification of market trends – need and criteria for the model	54
3.1 RCF as a source of competitiveness: the case of US mini-mills	54
3.1.1 Background: economies of scale	54
3.1.2 Success story of mini-mills	55
3.2 Integration with waste-to-energy.....	57
3.3 Possible next steps for applying W-t-E at paper mills	60
3.3.1 Waste as a dual source of fibre and fuel	60
3.3.2 Recycled-fibre-based bioethanol	63

3.4	Financial analysis of waste-to-energy in a paper mill environment	68
3.4.1	Set-up of the financial analysis	68
3.4.2	Key results of the financial analysis	74
3.5	Other pre-identified trends	79
3.5.1	Trends in RCP collection.....	79
3.5.2	Increasing importance of RCF rejects disposal.....	81
3.6	Summary and discussion of relevant trends concerning the RCF market.....	82
3.7	Observed need for an S/D model of the composite RCF market	84
3.8	Criteria for the new construct.....	85
4.	Modelling the supply-demand behaviour of recycled fibre.....	87
4.1	Introduction to price theory.....	87
4.2	Recovered paper (RCP) market overview.....	91
4.3	Previous econometric analyses of the RCP market.....	93
4.4	Supply-demand model of the composite RCF market.....	97
4.4.1	Recovered paper market.....	97
4.4.2	The interplay with the RCP and other markets	102
4.4.3	Summary of hypotheses related to basic market phenomena.....	109
5.	Delphi study on the supply-demand behaviour of recycled fibre	112
5.1	Description of the Delphi study.....	112
5.2	Key results of the Delphi panel.....	115
5.2.1	Demand development of RCP at paper mills.....	115
5.2.2	Substitute price development	117
5.2.4	Market development related to the energy utilisation of RCF.....	122
5.3	Key results from the perspective of scientific foresight.....	124
6.	Testing the proposed S/D model with Delphi outputs.....	131
6.1	Present RCP market in Europe	131
6.2	The composite RCF market in Europe.....	135
6.3.1	Main scenario by the year 2020.....	142
6.3.2	Alternative scenarios for the year 2020.....	148
6.3.3	Additional “post-Delphi” considerations.....	154
6.4	Conclusions from testing the model.....	156
7.	Conclusions	160
7.1	Answers to the research questions.....	160
7.2	Evaluation of the research	164
7.2.1	Theoretical criteria for constructive research.....	164
7.2.2	Practical criteria for the S/D model.....	166
7.2.3	Scientific foresight in the form of a Delphi panel	166
7.3	Epistemic and practical utility of the research.....	170
7.3.1	Contribution to knowledge.....	170
7.3.2	Practical contribution.....	171
7.4	Validity and reliability of the research.....	171

7.4.2	External validity	171
7.4.3	Construct validity	172
7.4.4	Reliability.....	173
8.	Discussion	174
8.1	Summary of the study.....	174
8.2	Managerial lessons of the study for the P&P industry.....	175
8.2.1	Likely emergence of fuel market for waste paper.....	175
8.2.2	New concept opportunities for paper mills.....	175
8.2.3	Systemic changes in managing discarded-paper-containing waste flows.....	176
8.3	Issues for future research	177
	References.....	179

Appendices

- Appendix I: Key statistics; including development of regional RCP collection and utilisation volumes and basic price data
- Appendix II: Delphi study on supply – demand behaviour of recycled fibre; invitation letter and problem description
- Appendix III: Delphi study on supply-demand behaviour of recycled fibre; summary of 1st round findings and the 2nd round questionnaire
- Appendix IV: Delphi study on supply-demand behaviour of recycled fibre; results of the 2nd round questionnaire

List of Tables

Table 1.1	Examples of Waste-to-Energy boilers at paper mills in operation or under construction.....	25
Table 2.1	Relevant situations for different research strategies.....	38
Table 2.2	Characteristics of different possible research strategies.....	42
Table 2.3	Types of experts about the future.....	47
Table 2.4	Research questions.....	50
Table 2.5	The research methods, research materials and data sources employed in the study.....	52
Table 2.6	Strengths and weaknesses of different sources of evidence.	53
Table 3.1	Examples of Waste-to-Energy boilers at paper mills in operation or under construction.....	59
Table 3.2	Main variables used in the financial analysis.	73
Table 3.3	Financial summary of the concepts.	74
Table 3.4	Pre-identified trends.	85
Table 5.1	Classification of the panellists.	114
Table 5.2	Key results of the Delphi study related to RCP demand development.	126
Table 5.3	Key results of the Delphi study related to substitute price development.	127
Table 5.4	Key results of the Delphi study related to RCP supply.....	128
Table 5.5	Key results of the Delphi study related to the energy utilisation of RCF.....	129
Table 7.1	Delphi study outputs by topic areas that are relevant for modelling market behaviour with the proposed S/D model.	168

List of Figures

Figure 1.1.	Annual recovered paper (RCP) usage in the paper industry.....	17
Figure 1.2.	Material flows with discarded paper content	19
Figure 1.3.	International trade flows of recovered paper in 1998 and 2007.....	22
Figure 1.4.	Structure of the dissertation	28
Figure 2.1.	Position of constructive approach.	40
Figure 2.2.	Elements of constructive research.	41
Figure 2.3.	Summary of the applied foresight typology.	45
Figure 2.4.	Phases of the research.....	51
Figure 3.1.	US mini-mills producing case materials, by start-up year.	56

Figure 3.2.	Typical Sankey diagram of waste material processed at the Karhula trials	61
Figure 3.3.	Mass balance of a 150,000 t/y Urban Mill integrated with a neighbouring CHP plant	62
Figure 3.4.	Principal process steps in converting wood biomass into EtOH.....	65
Figure 3.5.	Principal process steps in converting RCP into EtOH.....	65
Figure 3.6.	Mass balance of stand-alone Urban Ethanol concept.	66
Figure 3.7.	Urban Ethanol concept integrated with a large-scale RCF-based paper mill	67
Figure 3.8.	Benchmark – a modern non-integrated case-materials-producing paper mill.....	69
Figure 3.9.	“Urban Mill alternative 1” – Benchmark fitted with a modern W-t-E power plant.	69
Figure 3.10.	“Urban Mill alternative 2” – Benchmark integrated with a modern W-t-E power plant and boosted with fibre recovery from incoming waste streams	70
Figure 3.11.	“Urban Ethanol alternative 1” – stand-alone ethanol production utilising RCF content in the mixed waste streams.	71
Figure 3.12.	“Urban Ethanol alternative 2” – ethanol production integrated with a large-scale RCP-based paper mill.....	72
Figure 3.13.	Sensitivity of the modelled ROCE-% to key assumptions, part 1 ...	78
Figure 3.14.	Sensitivity of the modelled ROCE-% to key assumptions, part 2 ...	78
Figure 4.1.	Traditional supply and demand curves.....	88
Figure 4.2.	Elasticity of demand.....	89
Figure 4.3.	Composite demand as defined by Marshall, 1920.....	90
Figure 4.4.	Composite supply as defined by Marshall, 1920.....	90
Figure 4.5.	Indexed quarterly price development of pulp and recovered paper in 2001–2009.	92
Figure 4.6.	Simplified rotation of paper grades within the manufacture-use-recycle system.	93
Figure 4.7.	Aggregate demand for recovered paper.....	98
Figure 4.8.	The most important factors causing a demand shift for RCP.	99
Figure 4.9.	Aggregate global supply of recovered paper.....	100
Figure 4.10.	Aggregate supply and demand of recovered paper.....	102
Figure 4.11.	General model of the composite demand and supply of RCF.....	104
Figure 4.12.	Illustration of typical cost structures behind RCP Supply-curve (S_{RCP})	106
Figure 4.13.	Step 1: The SRF and RCP markets develop into a state of equilibrium	107
Figure 4.14.	Step 2: Surplus opportunity for the marginal RCP quantities on the fuel market	108
Figure 4.15.	Step 3: Bleed to SRF market results in a new balance.....	109
Figure 5.1.	Overview of the conducted Delphi study.....	113

Figure 6.1.	The RCP market in the CEPI area, cascaded by main grades.....	133
Figure 6.2.	European vs. the global RCP market	134
Figure 6.3.	Effect of exchange rate change	135
Figure 6.4.	Estimated demand schedule for MWP	137
Figure 6.5.	Estimated demand schedule for SRF	138
Figure 6.6.	Estimated supply schedule for MWP	139
Figure 6.7.	Estimated supply schedule for SRF	140
Figure 6.8.	Estimated supply and demand schedules for MWP and SRF	141
Figure 6.9.	Estimated shadow supply schedule of MWP as fuel (S_{RCPF}) in comparison to the MWP and SRF markets.	142
Figure 6.10.	Estimation of the present market status.....	145
Figure 6.11.	Main scenario 2020 ($P_{MWP}=110$ €/t)	145
Figure 6.12.	Main scenario 2020 ($P_{MWP}=150$ €/t)	146
Figure 6.13.	Main scenario 2020 ($P_{MWP}=200$ €/t)	146
Figure 6.14.	Development of MWP and SRF quantities 2010–2020.....	147
Figure 6.15.	Modelled development of the MWP and SRF price 2010–2020... ..	148
Figure 6.16.	Development of MWP and SRF quantities in line with the studied alternatives to the main scenario for 2020.	153
Figure 6.17.	Modelled development of the MWP and SRF price 2010–2020	154
Figure 8.1.	Possible new state of the paper collection and recycle system.....	177

1. Introduction

1.1 Background

The question of how best to utilise discarded paper could be considered a somewhat outdated dilemma. Twenty-to-thirty years ago the pulp and paper industry (P&P), especially in the Nordic countries, advocated the burning of waste paper, stressing the value of its energy content and the uselessness of its transportation back to remotely located paper mills (see e.g. Kärnä et al. 1994; Virtanen and Nilsson 1993). Later, the market began to favour recycling, stimulated perhaps partly by political decisions, but mostly for purely economic reasons. Thus, today, recycled fibre (RCF)¹ is globally clearly the most important papermaking raw material in terms of volume. See Figure 1.1. (Pöyry Forest Industry Consulting 2009).

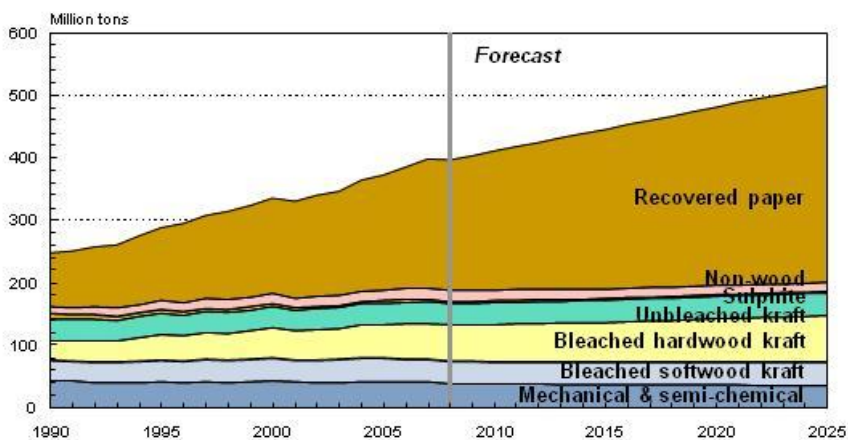

Figure 1.1. Annual recovered paper (RCP) usage in the paper industry.

¹ Almost all recycled fibre is today manufactured integrated at the papermills by using Recovered Paper (RCP) that is traded as tens of different sub-grades. See Chapter 1.5 for more detailed explanations of the key terminology used in this study.

Various scientific life-cycle assessments confirm the environmental and economic benefits of recycling over incineration or landfill. However, the margin between recycling and *efficient energy recovery* varies to some extent depending on the definitions of the systems studied and the geographic locations (Villanueva and Wenzel 2007, Dahlbo et al. 2005). Politically, recycling is widely considered the preferred option – e.g. the EU has established a hierarchy of waste management options which gives recycling priority over energy recovery (2008/98/EC).

As exhibited by the forecast of Figure 1.1., there is a clear expectation that the global market share of recycled fibre will continue to increase. This forecast is based firstly on the expected structure of future paper consumption, in which packaging materials (where RCP is already the main raw material) will dominate (Pöyry Forest Industry Consulting 2008). Secondly, the forecast is based on the expectation of increasing collection rates for discarded paper, enabling its increasing utilisation².

The paper industry's usage of recycled fibre appears to be plain sailing; it is expected to grow more or less as before, and political questions concerning the best ways of utilising waste paper became outdated long ago. However, there is an ongoing and potentially expansive development on the market that might undermine further increases in paper recycling. In the main RCP supply markets of Europe and the US, a further growth in the collection rate is being threatened by developments in waste-to-energy (W-t-E) that utilise waste flows incorporating, among other components, the discarded paper that currently remains outside recycling. This trend is being driven by a search for more viable waste management options to landfill, and a political interest in supporting biomass-based energy (including that based on wastes), and it has stimulated technical developments aimed at improving the efficiency of W-t-E. These include various concepts that utilise industrial combined heat and power (CHP) based on quality-controlled, waste-derived fuels (see e.g. Ristola 2002, Sipilä et al. 2009, Straetmans 2010).

Figure 1.2. provides a simplified overview of the various material flows that contain discarded paper. These include municipal solid waste (MSW) and various wastes of commerce and industry (CIW), as well as residues from different industrial operations that are advantageously further prepared into so-called Refuse-Derived Fuels (RDF)³ for efficient utilisation as energy in e.g. industrial combined heat and power production (CHP). The discarded paper content in these waste flows and consequently in RDF naturally varies to a large extent between countries and sources of waste. The typical paper and cardboard content in MSW is

² Pöyry expects the global collection rate to increase from 54% in 2008 to 63% by 2025. (Pöyry Forest Industry Consulting 2009).

³ Sometimes classified as Solid Recovered Fuels (SRF) – see Chapter 1.5 for detailed explanations.

20–30% in developed economies, and, when the high calorific fuel fraction has been screened out, the paper and cardboard content in it increases to 30–50%⁴.

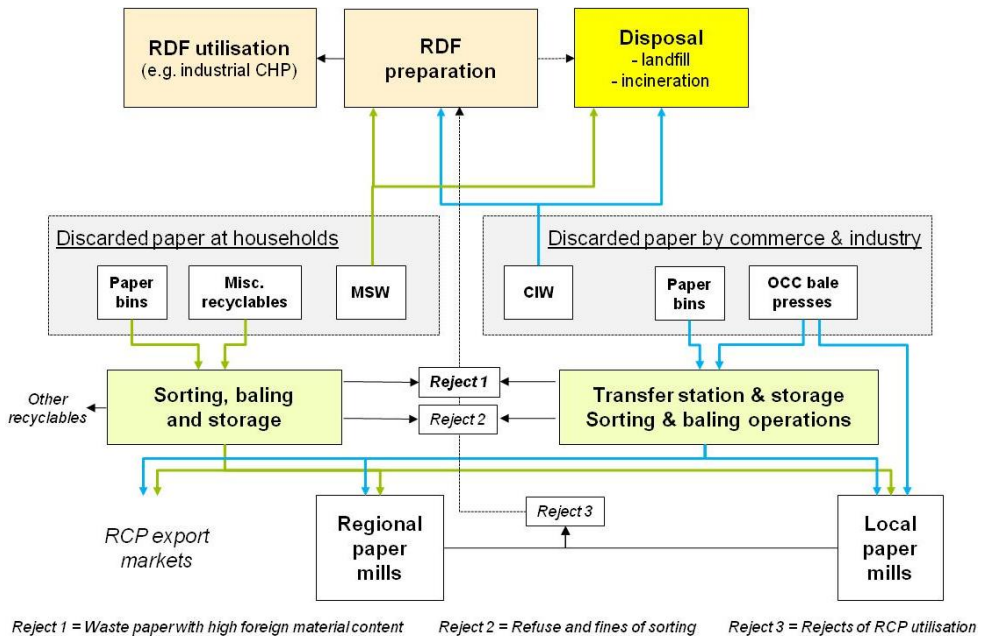

Figure 1.2. Material flows with discarded paper content.

The described trend is partly a consequence of the political agenda to mitigate global warming by increasing the fuel use of all biomass, including wastes. In this respect, legally binding targets were set by e.g. the EU landfill directive (1999/31/EC) and the EU RED directive (2009/28/EC). Another aspect is the technical benefits of W-t-E in industrial CHP, where special synergies are found at paper mills utilising recycled fibre. During the years 1999–2004, the author of this thesis was employed full-time in activities aimed at applying modern W-t-E technologies in a paper mill environment in a completely new way⁵ (see e.g. Ristola and Karlsson 2000, Ristola 2002, Ristola 2004a and Ristola and Mirata 2007). Since 2004, the author has been engaged in different endeavours in the field,

⁴ See e.g. Ristola 2004a, Beckmann et al. 2007, Hietanen 2009 for paper and cardboard content in RDF, Parfitt 2009, United States Environmental Protection Agency 2010, IPCC 2006 for paper and cardboard content in MSW.

⁵ At that time the author worked as a development manager at Metso Corporation and later at Metso Paper Inc.

while still maintaining contact with the research teams continuing the development work in 2005–2010⁶.

Questions concerning the price behaviour of recovered paper had long been of interest to the industry. What causes the strong fluctuation in the prices of RCP, for example? Can the changes in the market be predicted? (See e.g. Huttunen 1996, Bülow 2005, Ervasti 2006a, 2006b and 2007.) How far can utilisation rates still increase without collection falling seriously behind, or where are the limits of paper recycling (Stawicki and Read 2010)? Such questions have for long troubled practitioners – not only because recycled fibre contributes heavily to operating costs, but also due to the high capital commitments required for further expansions. In other words, what future price assumptions should be used in payback calculations for capacity expansions? Will the required RCP or RCF quantities be available at all in the future?

In the ranks of economics academics, the waste paper market has created considerable interest ever since the 1970s. E.g. Anderson and Spiegelman 1977, Gill and Lahiri 1980, Deadman and Turner 1981, Edgren and Moreland 1989 and Nestor 1992, have all published frequently cited research papers discussing the waste paper market, with particular focus on discussing and often questioning the rationality and effectiveness of policy instruments that are aimed at stimulating paper recycling. Later, in the 2000s, several Swedish researchers (e.g. Berglund 2003 and 2004, Berglund and Söderholm 2003, Lundmark 2001, Lundmark and Söderholm 2003 and Samakovlis 2003 and 2004) have continued discussing similar themes and improving the related mathematical functions and modelling approaches. This research includes attempts to achieve theoretical optimisation between recycling and incineration (e.g. Samakovlis 2004). However, it is questionable whether all this creditable work in economics gives ready answers to present problems, especially considering the dynamics in boundary conditions resulting from technical advances and the related new production concepts. Rather than explaining the market behaviour of the past, the present study focuses on what is to be expected in the future.

The author's personal involvement and later follow-up of the continuing research work created in him a genuine interest to understand formally, in scientific terms, ***how the developments in waste-to-energy will impact the paper industry and especially the recycled fibre market***. This thesis approaches this **research issue** through the following steps:

1. Confirm the relevance of the research issue by, for example, elaborating on reported market developments.

⁶ The development of the concepts has been pursued by a consortium of UPM-Kymmene, Lassila and Tikanoja, Pöyry, Skandinavisk Kemiinformation and VTT, the State Research Centre of Finland (see e.g. Ranta 2010, Sipilä 2010b). In the meantime, similar developments have also emerged elsewhere, such as by Fiberight LLC in North America (Fiberight 2012).

2. Identify suitable tools and theories to analyse the market by, for example, studying previous scientific works. In the event that gaps are found in the existing theories and understanding of the research issue, make an attempt to construct a model of the recycled fibre market.
3. Gain qualitative insight of likely market behaviour in the future by, for example, identifying trends impacting the supply-demand (S/D) behaviour of recycled fibre.
4. Make an attempt to quantify phenomena affecting the market – especially with respect to developments in waste-to-energy.
5. Draw conclusions on: a) the epistemic utility of the research findings, and b) the practical utility for the paper industry – how should it react with respect to the foreseen development?

Before entering into a more formal description of the research issue and objectives, let's take a closer look at some background aspects of this study. These include 1) basic information on the utilisation of recycled fibre by the paper industry, 2) some background on the utilisation of waste-to-energy by the paper industry, and 3) the growing use of biomass for fuel that obviously impacts the paper industry and, at least indirectly, the recycled fibre market.

1.1.1 Utilisation of recycled fibre in papermaking

Recycled fibre has been used as a papermaking raw material since before the emergence of large-scale paper manufacturing and wood pulp utilisation that took place in the latter half of the 19th century. Early papermaking raw materials such as rags, as well as the early wood pulps, were suitable for re-use in the papermaking process. At the beginning of the 20th century, corrugated containers began to establish their position as the most cost-competitive transportation packaging for many sorts of foodstuffs and durable goods. This also meant a major increase in recycling in the form of collecting and re-pulping old corrugated containers (OCC). Their recycling started to emerge almost immediately due to easy and economical re-processing, as well as easy sourcing in good quantities from places of commerce. In the 1970s, recycled fibre started to gain popularity as a raw material for printing papers – thanks to important developments in the de-inking process, i.e. the sub-process of recycled fibre preparation in which old ink is removed from the waste paper slurry and separated as a sludge-mix of ink, inorganic filler and fibre materials. Because of the high share of discarded paper in solid wastes, the use of recycled fibre has also been greatly influenced by political decisions to reduce waste paper disposal at landfills (e.g. Sillman 2009., Holik et al. 2000).

Today, recycled fibre is globally the most important papermaking raw material in terms of volume, and a cellulose fibre may face the consumer up to 5–7 times before its final disposal (Hamm et al. 2000, Ervasti 2006a, Ervasti 2006b, Ervasti 2007). Recycled fibre is, together with scrap metal, by far the most important sec-

ondary raw material and is traded very actively around the globe (ECE 1999). Its trade value exceeds EUR 20 billion annually. However, this business is not fully self-financed by revenues from secondary raw materials as household collection has quite often been partly financed by municipalities and tax payers (interview of Ervasti I. 2009).

Appendix I summarises the statistics on the collection and utilisation of RCP in the main global markets of Europe, USA and China. The statistics reveal the great imbalance that has formed between utilisation and collection in the growing Chinese market where, for cost and fibre availability reasons, about 75% of all new capacity is built on RCP. It further implies the need for increasingly high collection rates in Europe and the USA in order to supply the growing trade. Figure 1.3 depicts the main global RCP trade flows. The respective total RCP consumptions were approximately 130 Mt in 1998 and 207 Mt in 2007 (Pöyry Forest Industry Consulting 2009).

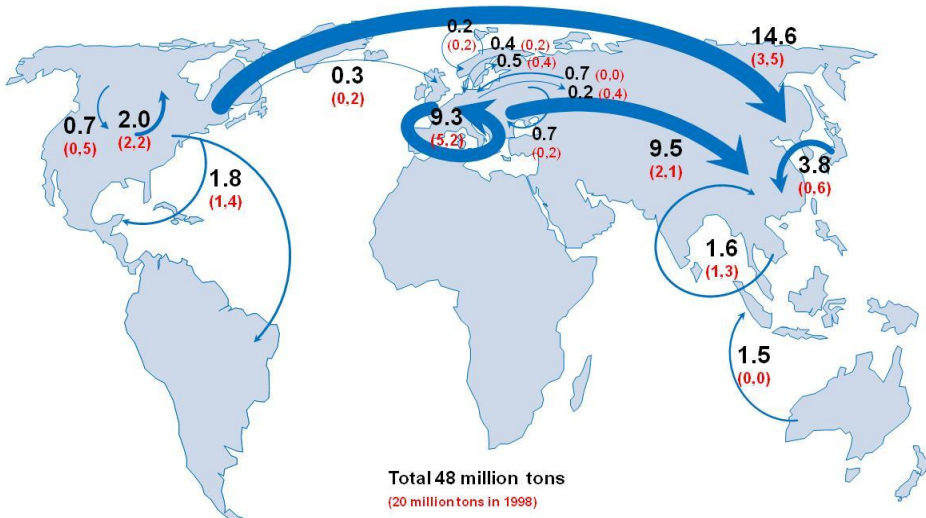

Figure 1.3. International trade flows of recovered paper in 1998 and 2007.

Together with the overall strong growth in RCP utilisation illustrated in Figure 1.1 this development poses the obvious and relevant question – where are the limits of paper recycling? How far can growth in utilisation be sustained? This topical question has recently been addressed by e.g. the European COST Action 48 (see www.Cost-e48.net) that collected research from 30 individual research organisations in 18 European countries to investigate various sub-sets of this larger question and resulted in a number of possible scenarios for the development of paper recycling (Stawicki and Read 2010). The conclusion from the work of COST48 is that the collection rate in Europe is estimated to increase from the present 64% (2007) to 71% by 2015. This yields an average year-on-year growth rate of 1.2%

in collection whereas the statistics in Appendix I demonstrate an average growth rate of 2.2% in the 1995–2007 period. Expert opinion therefore expects the growth in collection rates to become saturated as it approaches 70%⁷. In other words, the volumes beyond 70% will be more and more expensive to access and it might require substantial public funding – or a clearly higher price level for RCP – in order to finance the required new collection schemes. This is reflected in waste paper prices that have, on average, witnessed some 4% year-on-year growth during the last two decades (nominal, see Appendix I) and have lately stabilised at rather high levels, historically speaking.

Today recycled fibre has only marginal uses outside the paper industry. Such uses include, for instance, the production of cellulosic insulation material. It has been estimated that, today in Europe, some 4–5% of all recovered paper is destined for competing uses to paper manufacturing, while a similar amount ends up in energy recovery. In the US the figure is of similar magnitude (Stawicki and Read 2010, p. 90).

The share of discarded paper products in solid wastes and outside materials recycling is estimated to be 24% in the USA (US EPA 2010). In Finland, this figure was estimated at about 30% in the research by Metso Paper in 2003 (Ristola 2004a). In central Europe the figures are a bit lower; e.g. in the UK studies reported by Parfitt (2009 and 2010), paper and card account for 20–23% of the total. But if garden waste and food waste were collected separately, as in Finland, the share of discarded paper would be close to a level of one-third. Despite the variations, any eventual decisions to invest in efficient energy recovery from these waste flows are clearly important in the future development of the RCF supply for papermaking.

Another noteworthy aspect that stimulates the adoption of W-t-E by the paper industry is that the processing of recovered paper (RCP) into recycled fibre (RCF) for use at a paper machine always generates substantial amounts of various rejects. Depending on the grades of RCP and the intended use of RCF, a typical yield of RCF from RCP ranges from 60–95%. The low end is represented by quite complex processing of office waste into almost completely de-inked and de-ashed pulp for production of tissue papers and the high end is represented by the relatively simple processing of OCC for production of new case materials (Hamm et al. 2000).

In his 2005 article Bülow calculated the reject amounts and typical disposal costs in Germany in relation to one ton of ready RCF furnish in a headbox of a paper machine to range from 20–30 €/t depending on the cost level and the percentage of foreign material (Bülow 2005). The cost of reject disposal and treatment relate to the on-site preparation of the material for the consequent off-site treatments (typically by mechanical dewatering), but more importantly they relate

⁷ The latest European statistics for 2009 already report a collection rate of 72%. It has been suspected, though, that this is partly a result of the rapidly decreased consumption figures for 2009 and that 2010 should see a small decline in the collection rate (European Recovered Paper Council 2010).

to the gate fees commanded by the waste management operators for these different off-site treatments.

Recent developments in legislation, especially within the EU, have only increased the cost of reject disposal (Ristola 2004b). For instance, in Germany since 2005 the landfills have not accepted any untreated material. This has stimulated efforts to find less costly methods for rejects treatment and utilisation (Bülow 2005) and has clearly been one of the driving forces in waste-to-energy investments at paper mill sites (e.g. the case of Palm Wörth in Germany, as reported by Thalheimer and Haas 2008, Menke 2009).

1.1.2 Waste-to-energy technologies and their utilisation by the paper industry

Traditionally waste-to-energy power plants have been run separately, with the main purpose of incinerating municipal as well as commercial and industrial wastes. The energy output has remained marginal and the revenue from these operations has been based on long-term contracts with municipalities for the treatment of wastes. In modern mixed waste incinerating grate boilers, only around 20–25% of the fuel value of the wastes is converted into electricity (Vesanto 2006). In older plants much lower efficiencies can be found. In Sweden a popular arrangement has been the production of district heat by W-t-E, which considerably raises the total efficiency of operations, but is somewhat limited by seasonal variations in heat demand (Vesanto 2006).

For years already, a combination of RCF-based papermaking with W-t-E has been known to hold significant synergies because of paper mills' high year-round demand for low pressure steam and the generation of different types of rejects or tailings from the utilisation of RCF (see e.g. Ristola and Karlsson 2000). Normally, however, W-t-E operations at recycled-fibre-based paper mills have been limited to energy recovery from process tailings; i.e. sludges and rejects of RCF processing (Ristola 2004b, Bienert and Hanecker 2003, Götz and Pfaff 2003). During the 2000s, investments in W-t-E at paper mill sites have started in earnest and increasingly include RDF in their fuel mix. Some examples of recent or on-going boiler investments at RCF-based paper mills are listed in Table 1.1. The described trend has been very strong to date in Germany, and it is relevant to enquire whether a similar trend will take place in other European countries.

Table 1.1. Examples of Waste-to-Energy boilers at paper mills in operation or under construction⁸.

Paper mill	Country	Boiler MW	Fuel	Operator	Start-up
StoraEnso Varkaus	FI	50	Residues, gasifier	StoraEnso	2001
SCA Witzenhausen	GE	124	Residues + 265 ktpa RDF	SCA	2008
Sonoco Karhula	FI	35	MSW, 87 ktpa	Kotkan Energia	2008
Palm Wörth	GE	54	Residues + combi-cycle		2008
Klinge Weener	GE	70	140 ktpa RDF	Prokon Nord	2008
Jass Rudolfstadt Schwarza	GE	~30	RDF, 60 ktpa		2008
Hürth-Knapsack	GE	~120	Residues + RDF, 240 kt/a	E.On	2009
Leipa Schwedt	GE	136	Residues + max 220 kt/a of RDF	E.On	2010
Propapier, Eisenhüttenstadt	GE	150	Residues + 250 ktpa RDF + coal	EnBW	2010
StoraEnso Langerbrügge	BE	125	Residues + RDF + PDF	StoraEnso	2010
StoraEnso Maxau	GE	155	Residues + biofuel + PDF + coal, 210 ktpa	StoraEnso	2010
Steinbeis Temming, Glückstadt	GE	?	Residues + RDF	Steinbeis	2010
Hamburger, Spremberg	GE	~120	Residues + RDF, 250 kt/a	Hamburger	2012

In virgin-fibre-based P&P integrates, one can practically always find a solid fuel boiler capable of generating energy from process tailings such as bark, supplemented by different external fuels. Why didn't a similar trend start at RCF-based mills earlier? The likely reasons include not only technical advances in fuel preparation and standardisation, as well as in boiler technology, that together contribute to the efficiency and availability of the equipment⁹, but also the legislative push that has made operating and investing in waste-to-energy plants attractive (interview of Sipilä K. 2011). In addition one has to acknowledge various "inertia" effects that slow down the commercialisation of new and unconventional concepts (e.g. waste treatment operations at *paper mill sites!*) and typically result in long lead times of 3–6 years from idea to planning to permitting to project (ibid.). Chapter 3 of this study will elaborate in more detail why and how this development is likely to continue.

1.1.3 Fuel use of biomass and the paper industry

The rapid growth of the world economy in 2005–2008 put pressure on the supply of most raw materials, including RCP. Despite temporary downturns in the world economy, the trend for most raw material prices to increase is likely to continue. Within this general trend, biomass and biofuels are attracting special attention, largely due to attempts to mitigate climate change, but also because of a more

⁸ Based on trade press information and company releases on their internet pages.

⁹ The main technical factors that have contributed to this include fluid bed combustion (low share of unburnt in ashes and suitability for multifuel operations – e.g. use of sludges) and the quality control of fuels to minimise hot corrosion due to chlorides (interview of Sipilä K. 2011).

general interest in creating some (hopefully significant!) independence from fossil fuels.

In this situation, wood-based biomass – the ultimate raw material behind recycled fibre as well – is being subjected to unprecedented competition. There are great aspirations concerning the future potential of biomass for energy, especially in the European Union and the United States. The European Commission has declared an increase in the use of renewable energy sources to 20% of the aggregate energy use of all its fuels by 2020 (2009/28/EC). Within renewables, the share of biomass is today decisive; wood accounted for a half of all renewables in the EU in 2004–2007 and fuel use accounted for 42% of the entire wood utilisation (Steierer 2010).

At the same time the European Commission is insisting that the minimum content of renewable transportation fuels must rise to 10% by 2020 (2009/28/EC). Again, the primary source of renewables is assumed to be biomass, and the attention is on wood in addition to agricultural (by)products. However, the utilisation of wood biomass is limited by its availability – not necessarily by annual growth, but by the ecological, technical and social constraints that especially affect the amount of forest residues and stumps available for utilisation (e.g. Verkerk et al. 2010, Karjalainen et al. 2004). The supply of wood biomass might well become a limiting factor in wood utilisation and also affect the availability and price of round wood for forest industries. The main conclusion of the recent EUwood project (Mantau et al. 2010) was that the problem in meeting all the forecast needs for wood is not the theoretical availability of wood, but how to economically mobilise the required supply from the European forests. This is likely to call for policy measures with trade-offs regarding biodiversity and nature conservation (Prins 2010).

Another significant source of biofuels can be found among wastes. MSW typically has a renewable content of around 50%. Thus the potential contribution of waste-to-energy is significant. It is a major source of fuel biomass and its development is consequently a focus area on the political agenda (European Commission Biomass Action Plan 2005, interview of Sipilä K. 2009). Discarded paper is a potential fuel as well and has a very high renewable content. While the energy utilisation of recovered paper is against the hierarchy of waste management options as set out in the EU Waste framework directive (2008/98/EC), a new situation of competition for discarded paper utilisation could in theory emerge, especially as more advanced conversion techniques are introduced.

All this development around renewable energy is occurring at a time when a serious supply-demand imbalance with respect to recycled fibre has already started to emerge *inside* the paper industry, as already referred to in the previous section. This becomes apparent when one studies the statistics of supply and demand for waste paper (see Appendix I): most new papermaking capacity is being built in the Far East, and about 75% of it utilises recovered paper as its main raw material. At the same time, the limitations in supply are gradually being met in the main supply markets, i.e. in Europe and North America (where most of the paper is being consumed).

The current market status of tight supply on the RCP market, the political endeavours concerning the bio-energy sector and the technical fit of waste-to-energy at recycled-fibre-utilising paper mills have together led the market into a situation where the once anachronous dilemma of recycling vs. incineration has again become topical.

1.2 Research issue and objectives of the research

Proper scientific research begins with a definition of the problems or issues to be studied. The definition of the research issue is followed by a description of the research design, explaining the connection between various research problems and questions, the acquired empirical data, and the techniques of analysis used in order to reach conclusions. The target is transparent reporting of research that meets the rigour necessary for scientific conclusions. (Yin 1984 and Stake 1995, both in Lanning 2001)

The research issue of this study is to understand **the impact of waste-to-energy on recycled-fibre-based papermaking**. During the research process, the research issue was gradually refocused more towards an understanding of its **impact on the recycled fibre supply and demand relationships**. This happened because the energy use of paper-containing waste flows and the use of recovered paper for recycling were found to form a special kind of *composite demand*¹⁰ for recycled fibre. They ultimately compete for the same limited supply, i.e. the discarded paper. This **research issue** can be formulated into more specific **research objectives** as follows:

- i. **Confirm the relevance** of the research issue and **establish criteria** for suitable tools and theories in the study of the RCF market.
- ii. **Identify suitable tools and theories** that can be used to study how the market deals with competing demands that tolerate different physical forms of RCF; i.e. including the trade of discarded paper as RCP, trade as part of the various fuel streams, other forms of utilisation, and the final disposal.
- iii. In the event that gaps are found in the existing theories and understanding of the research issue, **construct a model of the composite RCF market**.
- iv. **Gain foresight of the phenomena that are likely to take place on the RCF market** in a time perspective that corresponds with the strategic planning needs of the pulp and paper industry, i.e. about 10 years.

¹⁰ In his landmark work "Principles of economics" Alfred Marshall (1920, Book V, Chapter VI) defines *composite demand* as the compounded total demand for a certain commodity or factor of production that is formed by its rival demands in different branches. Here, Marshall's concept is somewhat extended to cover a composite market of all discarded paper-containing flows, acknowledging their different physical forms.

- v. Jointly apply the model and the achieved foresight – **what is likely to happen on the composite RCF market under different conditions.**
- vi. **Evaluate the epistemic and practical utility** of the results and chosen research approach – how valid and reliable are the results, and whether such a combination of composite market model and scientific foresight could find applications in approaching other, analogical problems.

The research design of this study will be explained later, under a separate heading. (See Chapter 2, Research Methodology and Design.)

1.3 Structure of the dissertation

The structure of this report is depicted in Figure 1.4. This first chapter describes the background and general motivation behind the study, defines the research issue and research objectives, outlines the structure of the report, specifies some important areas excluded from the scope of the study, and finally includes definitions of central terminology and the key abbreviations used in the report for ease of reading.

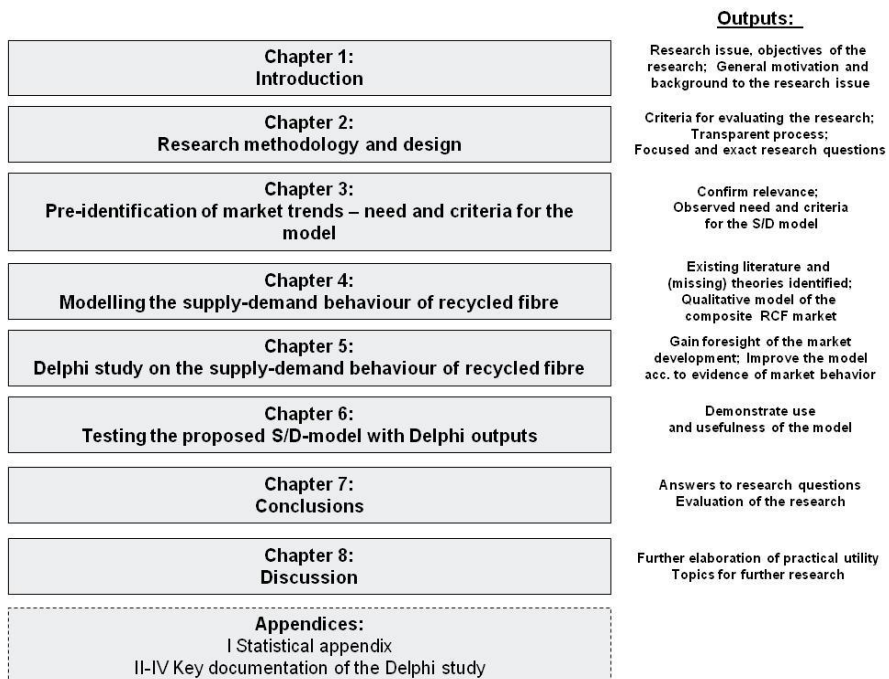

Figure 1.4. Structure of the dissertation.

Chapter two describes the research methodology and design used in the study, and provides the transparency necessary for evaluating the research. It also formulates the research objectives into focused and exact research questions.

Chapter three gives a detailed description of some of the developments that have led to the topicality of the research issue. Their potential impacts are summarised by a simple financial analysis. Chapter three finishes with a summary of the pre-identified trends that have a potential impact on the composite RCF market. The criteria for a model of the composite RCF market are defined.

Chapter four makes reference to general price theory and previous scientific work in the field of econometric analysis of the waste paper market. This yields the theoretical motivation for this research and connects it to the body of knowledge in economics. This is followed by a proposal for a model of supply and demand of the composite RCF market.

Chapter five describes the results of the Delphi study that was carried out as a central element of this study. The Delphi study, i.e. the expert panel set up by the author, serves three important purposes in this research: 1) it provides important insight and support in constructing the market model, 2) it identifies the main qualitative trends and development scenarios related to the composite RCF market, and thereby 3) it creates a basis for testing the model.

Chapter six presents a synthesis of the Delphi study outputs with the proposed market model. It acts as the testing stage for a new construct and presents the practical utility of the study.

Chapter seven evaluates the research against the research methodology, and analyses its epistemic contribution. Chapter eight discusses the results of the study and identifies potential areas for future research.

The appendices consist of: I) key statistics describing the development of the RCP market in the past, and II–IV) key documentation of the Delphi study.

1.4 Some important exclusions

This study is not concerned with detailed descriptions and assessments of the actual technical developments in Waste-to-Energy nor in the related conversion technologies¹¹. However, these provide the motivation for this study (as explained further in Chapter 3). The description of the technical concepts and their financial analysis are based on mass and energy balances, and on operating and capital expenditure estimates, from the published and unpublished works of the various research teams where the author of this study has been involved either personally or by way of close follow-up. This information is mostly based on industrial reference projects, and, in the case of those technologies still under development, on

¹¹ Such technologies include efficient co-combustion of solid recovered fuels and process rejects, separation technologies to recover cellulosic fibre from miscellaneous solid wastes, hydrolysis of RCF and its subsequent conversion into EtOH and biogas.

pilot trials done at a semi-industrial scale. Any assessment of the actual technical merits and hurdles related to these developments are considered to be outside the scope of this thesis.

Research activity in biomass-based renewable energy is currently escalating. Under these circumstances new ideas that at least indirectly also impinge on RCF utilisation are likely to evolve beyond any of those covered by this study. Such developments can, in theory, make the concepts presented in this study more or less obsolete. However, for the conclusions of this study, this has little importance. Such new research is likely to only underline the findings of this study, even though the most competitive technical solutions may differ¹².

From the geographical and market perspective, the main focus of this study is in the European context. The European Union has adopted perhaps the most active role in the fight against climate change and the perturbing reliance on fossil fuels. This portends major turbulence in European market conditions. Moreover, the European P&P industry is economically quite important and the EU area is globally the biggest supply market for RCP. The vital interaction between the global RCP market and the European market is explained in Chapter 6.1.

1.5 Terminology and abbreviations

In this study the statistical information provided as a background or evidence for the conclusions often covers the so-called *CEPI Europe*. CEPI (the Confederation of European Paper Industries, www.cepi.org) has successfully developed, and keeps following up, all the key pulp and paper industry statistics, including recovered paper statistics. CEPI Europe consists nowadays of Austria, Belgium, the Czech Republic, Denmark, Finland, France, Germany, Hungary, Ireland, Italy, the Netherlands, Norway, Poland, Portugal, Slovenia, Spain, Sweden, Switzerland and the United Kingdom. CEPI Europe covers more than 90% of European paper consumption and production. Therefore, in the context of this study, *Europe* usually means CEPI Europe, rather than the geographical concept of Europe.

CEPI has also introduced several tools and definitions to help catalyse the recovered paper trade. The classification of recovered paper grades by CEPI is very detailed and widely used, but this study most often refers to the four generic grades OCC, ONP/OMG, MWP and HG/PS, all of which are explained below.

a.r. As received. The amount of material or feedstock is expressed as wet weight, in the moisture the material is received with.

¹² One example is a Canadian company Enerkem that has already been very active in developing and piloting technology for processing waste into biofuels on an industrial scale (Enerkem 2009). Another example is the US company Fiberright LLC, based in Maryland, that is developing ETOH conversion from various waste flows, including cellulosic content in MSW (Fiberright 2012).

Ash	With respect to paper, ash refers to the mineral pigments and fillers used to improve the paper's properties and cost structure. Technically it refers to the remaining ash in a paper sample after burning it under controlled temperature. The inorganic content in paper is problematic in recycling as the functional value of the used mineral is difficult to re-capture.
Capex	Capital expenditure or investment cost. Capex/t refers to the relative investment cost per ton of production capacity gained by the investment.
CHP	Combined heat and power. Simultaneous production of electricity and low-pressure process steam (or district heat) by means of a back-pressure steam turbine. Commonly used in P&P industry power plants and Nordic municipal power plants connected to district heating systems. Increases the typical efficiency of energy conversion from approximately 40% (electricity only) to 85–90% (combined heat and power).
CIW	Commercial and Industrial Waste. It refers to the mixed waste of commerce and industry. See MSW.
Collection rate	Collection of RCP divided by paper consumption (typically within a country or a larger area).
De-inking	A stage in the preparation of recovered paper for use in the paper machine, in which old ink is detached from the fibre suspension, flotated by means of small air bubbles and removed from the process as a kind of froth. A certain amount of filler and the finer fraction of the fibre material is removed together with the ink. Thus, when processing recovered paper, the yields always substantially decline if the pulp is de-inked.
Discarded paper	Used or unused paper that is no longer of use to consumers, and is therefore discarded. Depending on local collection schemes and the actual waste bin where the paper is placed, it joins one of the many waste or secondary raw material flows.
EBIT	Earnings before interest and taxes.
EBITDA	Earnings before interests, taxes, depreciation and amortisation.
HG/PS	High grades and pulp substitutes. Includes e.g. sorted office waste paper, white shavings from printing operations and other so-called pulp substitutes.
MSW	Mixed Solid Waste or Municipal Solid Waste. It refers to mixed, unsorted household waste. On a case-by-case basis, the mixed waste of commerce and industry (CIW) is either mixed with

	waste originating from households, or collected, treated and utilised separately.
MWP	Mixed Waste Paper. It refers to mixed, unsorted waste paper, usually collected from households. Sometimes it refers to waste paper collected from commerce and business that is rich in corrugated containers but lacks the minimum content for classification as OCC without additional sorting.
Negative sorting	Sorting of material flow in which the amount of impurities is reduced by picking out foreign material from the flow being sorted. The content of foreign material or impurities typically remains higher in negative sorting than in positive sorting. See positive sorting.
OCC	Old corrugated containers. It refers to a grade of waste paper primarily consisting of used corrugated containers. It is collected mainly from places of commerce. It is one of the main commercial waste paper grades.
Office waste	Discarded paper collected from offices. It typically contains mainly white cut-size office papers with high brightness and low ink content. The main grades are Mixed Office Waste (MOW) and Sorted Office Waste (SOW) that has been sorted more carefully to remove coloured papers and other miscellaneous paper discarded in offices. Office waste is classified as HG/PS.
ONP/OMG	Old newspapers and old magazines. It refers to post-consumer waste paper collected at households and working places containing mainly old newspapers and old magazines. It is one of the main commercial waste paper grades. ONP and OMG are often referred to as a commingled fraction ONP/OMG though ONP is also traded separately.
Opex	Operating expenditure. Covers both variable and fixed operating cost. Opex/t refers to the operating cost per ton of the final product.
Positive sorting	Sorting of material flow in which the amount of impurities is reduced by picking out the desired fraction from the flow being sorted, leaving the impurities in the flow. The content of foreign material or impurities typically remains smaller in positive sorting than in negative sorting. See negative sorting.
RCF	Recycled fibre. Cleaned and screened secondary fibre raw material. RCF is mainly produced by processing RCP in production plants that are integrated with paper mills. Therefore, the usual object of trade is not RCF, but one of the RCP grades. In this study the composite RCF market is formed by different carriers of RCF, the majority of which is today traded as RCP.

RCP	Recovered Paper. It refers to discarded paper that is separately collected and sorted, as necessary, to fulfil certain commercial specifications. RCP appears in tens of sub-grades, the most important of which can be grouped under OCC, ONP/OMG, MWP, or HG/PS.
RDF	Refuse-derived fuel (in German Ersatzbrennstoff – “EBS”); c.f. SRF. Waste-based fuel that has been manufactured for the purposes of efficient energy conversion. RDF production typically includes size reduction, screening off wet fines of the waste, metals separation and some quality control of the materials fuel properties.
ROCE	Return on capital employed.
S/D	Supply and demand.
SRF	<p>Solid recovered fuel. A specific European classification system for refuse-derived fuels (RDF) that precisely specifies the chemical characteristics of the fuel and requires a degree of quality control. According to ERFO (2009): “Solid fuel, prepared from non-hazardous waste to be utilised for energy recovery in incineration and co-incineration plants, while meeting the classification and specification requirements laid down in prEN15359 (European Standardisation Committee). Note: “in this context, the term ‘prepared’ means processed, homogenised and up-graded to a quality that can be traded amongst producers and users”.</p> <p>The SRF acronym is systematically used in the context of the proposed S/D model of the market. SRF has been selected because the current fuel market is not at all homogenous and because the goal is to analyse possible interactions, especially between the low end of the fibre market and the high end of the fuel market, i.e. the SRF market. In other contexts, the more general term RDF is often used, as it covers a broader spectrum of waste-based fuels.</p>
Utilisation rate (or uti-rate) of RCP	<p>The consumption of RCP divided by paper production (typically within a country or larger area). N.B. The uti-rate can exceed 100% in cases of very high market share of RCP and a low yield from RCP to RCF.</p>
Waste paper	Sometimes used as a synonym for recovered paper (RCP), but is more accurately a synonym for discarded paper. To avoid misunderstandings, this study uses the more accurate terms – recovered paper and discarded paper.

1. Introduction

W-t-E Waste-to-energy. It refers to all energy uses of waste in which there is at least some energy recovery. In normal mass incineration, the efficiency of energy conversion is very low. More recent developments include CHP, combined cycle power plants and gasification. The paper mill is, by nature, an ideal companion for a Waste-to-Energy power plant as it enables efficient CHP operation at very high annual rates.

2. Research methodology and design

This chapter first explores the possible research methodologies and strategies. The objective was to identify suitable research methods for the research issue and objectives introduced in Chapter 1. It is presumed that no single research method is capable of providing answers for the cross-disciplinary research objectives of this study. This chapter also defines the exact research questions and ends by laying out the corresponding details of the research design and data used in this study.

2.1 Potential research strategies

The background described in Chapter 1 pinpointed the gradually tightening supply of RCP in a situation where new uses or markets for discarded-paper-containing waste streams are emerging in the waste-to-energy sector, thus at least indirectly disturbing the RCP market. The *research issue* was defined broadly as **the impact of waste-to-energy on the recycled fibre market**. Consequently, the *research objectives* were defined as follows:

- i. **Confirm the relevance** of the research issue and **establish criteria** for suitable tools and theories in the study of the RCF market.
- ii. **Identify suitable tools and theories** that can be used to study how the market deals with competing demands that tolerate different physical forms of RCF; i.e. including the trade of discarded paper as RCP, trade as part of the various fuel streams, other forms of utilisation, and the final disposal.
- iii. In the event that gaps are found in the existing theories and understanding of the research issue, **construct a model of the composite RCF market**.
- iv. **Gain foresight of the phenomena that are likely to take place on the RCF market** in a time perspective that corresponds with the strategic planning needs of the pulp and paper industry, i.e. about 10 years.
- v. Jointly apply the model and the achieved foresight – **what is likely to happen on the composite RCF market under different conditions**.

- vi. **Evaluate the epistemic and practical utility** of the results and chosen research approach – how valid and reliable are the results, and whether such a combination of composite market model and scientific foresight could find applications in approaching other, analogical problems.

How best can the set of research objectives outlined above be tackled in a rigorous scientific manner? As discussed in Chapter 1, economists have previously studied the price behaviour, i.e. the supply and demand relationships of recovered paper, by using econometric analysis (Lundmark and Söderholm 2003). Econometric analysis or econometrics is a subdiscipline of economics that utilises quantitative methods, mathematical modelling and particularly statistical analysis (Hashem 1987). In economics, the stimulus for use of mathematical methods has been the desire to use an empirical approach more akin to the physical sciences (Clark 1998). Commonly used mathematical methods range from calculus, linear algebra and statistics to game theory and computer sciences (Debreu 1987). Applications range from optimisation problems to static analysis and comparative statics (i.e. the change from one equilibrium to another induced by a change in one or more factors) and dynamic analysis (Chiang and Wainwright 2005).

In studying the recovered paper markets, scholars have used production or cost functions in their different forms, ranging from linear supply-demand models to constant elasticity of substitution, to Cobb-Douglas or translog forms. Most modelling has been based on partial static equilibrium analysis, in which a single market is studied independent of its substitutes and complements (e.g. Nestor 1992), whereas some of the more recent analysis is based on general equilibrium (e.g. Samakovlis 2004). The data used in testing has typically been local or regional, the time series have been long, and the data used has mostly been aggregated on an annual level (Lundmark and Söderholm 2003). Obviously, any work attempting to model the supply-demand behaviour of recycled fibre has to reference and build on these works.

Although mathematical economics is sometimes criticised for its low replicability, due to the quality of the data (too broad, too aggregated), the concept of *falsifiable hypothesis surviving tests* in the spirit of Popper (e.g. Thornton 2009) is a common criterion for acceptance. Criticisms of mathematical economics include an early argument by Friedrich Hayek that it often projects a scientific exactness that does not appropriately take into account the informational limitations faced by real economic agents (Hayek 1945). Critical tones have also lately been expressed by e.g. Heilbroner (1999). Nevertheless, mathematical economics can today be considered the mainstream in economics. Bushaw and Clover (1957) have stated that “few people are ingenious enough to grasp the more complex parts of price theory without resorting to the language of mathematics, while most ordinary individuals can do so fairly easily with the aid of mathematics.” Solow likewise states that mathematical economics is indispensably the core “infrastructure” of contemporary economics (Solow 1988).

As the research objectives of this study relate to the possibility of quite fundamental changes in the supply-demand behaviour of recycled-fibre-containing flows

and in the related business environment *in the future*, models based on statistical evidence from the past are (alone) unlikely to possess sufficient predictive credibility. This calls for a deeper understanding of the related phenomena – expressed through *how* and *why* questions. *How is it working and why is it working like that?* (Gummesson 1993, p. 129, Niiniluoto 1980, p. 71 both in Lanning 2001). Susman and Evered (1978, pp. 599–600, also in Lanning 2001) further suggest that when the reason for conducting research is to solve a problem, researchers should be sceptical of positivist science; i.e. in such cases the choice of research methods is likely to include qualitative elements. In fact, much of classical economics can be presented qualitatively in simple geometric terms or elementary mathematical notation, though it has been argued by Alfred Marshall that every economic problem which can be quantified, analytically expressed and solved, should be treated by means of mathematical work (Brems 1975).

The cross-disciplinary nature and future orientation of the research objectives in hand invites us to investigate research methods beyond economics in the fields of management research and business administration, and in particular in the *scientific study of the future*. As the research methodology of scientific future studies is clearly separate from mainstream business economics, its general epistemic foundations are discussed separately in Chapter 2.2.

Within the field of business administration, Kasanen et al. (1993) summarise the different characteristics of research as follows:

- quantitative versus qualitative research
- positivistic (descriptive) versus hermeneutic (interpretive and critical research)
- research based on large vs. small empirical samples.

Naturally these characteristics are not black and white and are also somewhat overlapping, but they are quite effective in differentiating the positivist tradition from its alternatives. The positivist tradition typically prefers quantitative theories, backed up by large empirical samples. It claims to eliminate values from research. As Kasanen puts it: “quantitative phenomena (viewed as objective ‘facts’) are studied with law-like generalizations as the ultimate aim of the whole research endeavour” (Kasanen et al. 1993, p. 254). Obviously this can be viewed as a shortcoming in many fields of social sciences, including business economics, where the studied phenomena are very complex and involve subtle interdependencies that are difficult to measure.

Qualitative research, on the other hand, uses qualitative or descriptive data. In qualitative research, empirical data is typically collected from the field through interviews or observations. In comparison with the positivist tradition and large samples of numerical facts, its central problem is related to the measurement of variables, i.e. the limited ability to quantify findings (Kasanen et al. 1993, p. 254).

The aim of hermeneutic research is to find relationships between phenomena and to test the hypotheses related to them, either by experimental or non-experimental means. (Järvenpää and Kosonen 1997). It is usually qualitative by nature. The most significant difference from the positivist tradition is its acceptance

2. Research methodology and design

of a certain amount of subjectivity as a legitimate part of science (Kasanen et al. 1993, p. 254).

The positivist and hermeneutic paradigms are not at all mutually exclusive as research methods for a single piece of research – quite the contrary. This has also been recognised by the school of researchers that promotes the building of theories from case study research. Bent Flyvbjerg, for example, has argued that the quantitative-qualitative divide in social research is unfortunate and that good research methods often rely on both quantitative and qualitative data (Flyvbjerg 2011). Eisenhardt points out that quantitative evidence may indicate factors and relationships which otherwise would remain hidden to the interpretive researcher. On the other hand, qualitative data helps the researcher to understand the rationale and reasons for relationships revealed by the quantitative data and may directly suggest a theory which, in turn, can be confirmed by quantitative means (Eisenhardt 1989, p. 538).

One popular method in social sciences is *case study research*. In case studies the definitions of Yin (1989, in Koskelo 2005) are often referred to. According to Yin, the case study method is relevant when research questions are of the form “how” or “why” and they don’t require control over behavioural events. See Table 2.1 (Yin 1989, in Koskelo 2005).

Table 2.1. Relevant situations for different research strategies.

Research strategy	Form of research question	Requires control over behavioral events?	Focuses on contemporary events ?
Experiment	How, why	Yes	Yes
Survey	Who, what, where How many, how much	No	Yes
Archival analysis	Who, what, where How many, how much	No	Yes /No
History	How, why	No	No
Case study	How, why	No	Yes

Yin defines case studies as follows (Yin 1989, p. 23, in Koskelo 2005):“A case study is an empirical inquiry that:

- investigates a contemporary phenomenon within its real life context, when
- the boundaries between the phenomenon and the context are not clearly evident, and in which
- multiple sources of evidence are used.”

Yin further defines the five most important components of case study research (Yin 1989, p. 29, in Koskelo 2005) as:

- a study's questions
- propositions, if any → each proposition is directed at something which should be examined within the scope of the study
- its units of analysis → a fundamental problem of defining what the “case” is
- the logic linking the data to the propositions, and
- the criteria for interpreting the findings.

Yin scrutinizes case study research and divides it into three main phases: design, single case data collection and analysis, and cross-case analysis (Yin 1989, p. 56, in Koskelo 2005). Case study research is a relatively widely used method of acquiring and analysing data in the social sciences, because it can generate relatively in-depth findings from a limited sample while maintaining rigour in interpretation, thanks to careful cross-case analysis.

Action research is a form of research in which the researcher, in addition to doing research, uses the data to develop the research object (Järvenpää and Kosonen 1997). This action-oriented research approach requires a thorough understanding of organizational processes in order to make the intended changes in an organization. Action research combines the generating of theory with the making of changes in the social system, through the way the research acts in the social system. “Action researchers demand that research should be relevant for scholars whose purpose is to advance the current state of knowledge and for practitioners who, in turn, struggle with their problems in a system” (Lanning 2001, p. 48). Both action research and case study research are clearly focused on the study of organisations.

Kasanen et al. (1993) suggest a special form of normative research called *constructive research*. They define it as follows:

- Constructive research produces an innovative theoretically grounded solution for a relevant problem.
- The usefulness and usability of a construct is shown.
- The scope of applicability of the solution is considered.

Constructive research may include both quantitative and qualitative material. Typically, the constructive approach is based on a limited number of case studies. Due to its concrete objectives, constructive research is not descriptive, but is rather decision-oriented. It is normative research. Theoretical analysis and thinking are important, leading to the innovative creation of a new entity: a construct, model, method or way of acting, and a demonstration of the practical usability of the constructed solution (Kasanen et al. 1993, pp. 254–256).

Constructive research has similar features to action research. In constructive research the aim is to create a new construct, e.g. a way of acting, whereas action

2. Research methodology and design

research aims at explaining phenomena and making changes in the studied system by the conduct of the research work (Koskelo 2005, p. 12). Kasanen et al. (1993) (1991, in Lanning 2001, p. 46) also point out that less pragmatic targets, like knowledge creation, can be covered by constructive research. Figure 2.1 positions constructive research among other methodologies in business administration using the widely accepted classification of Neilimo and Näsi (1980, in Kasanen et al. 1993, p. 255–257). The constructive approach is normative and uses empirical evidence mostly.

	<i>Theoretical</i>	<i>Empirical</i>
<i>Descriptive</i>	Conceptual approach	Nomomethical approach Action-oriented approach
<i>Normative</i>	Decision-oriented approach	Constructive approach

Figure 2.1. Position of constructive approach.

According to Kasanen et al. (1993, p. 246), in the constructive approach, the research process may be divided into the following phases (also illustrated in Figure 2.2):

- Find a practically relevant problem which also has research potential.
- Obtain a general and comprehensive understanding of the topic.
- Innovate, i.e. construct a solution idea.
- Demonstrate that the solution works.
- Show the theoretical connections and research contribution of the solution.
- Examine the scope of applicability of the solution.

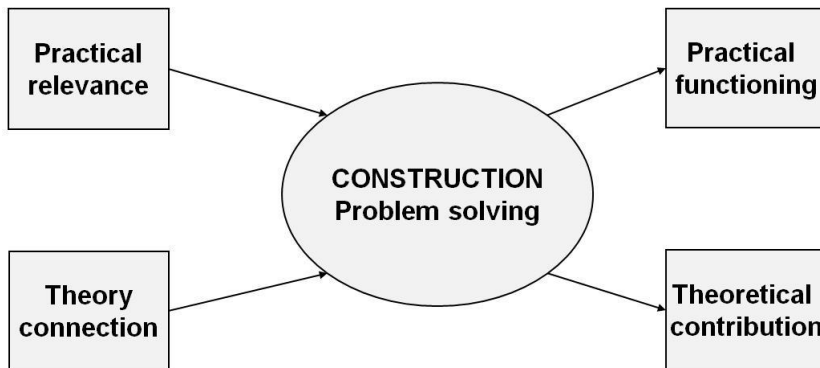

Figure 2.2. Elements of constructive research.

Niiniluoto (1992, in Lanning 2001 p. 43) discusses the concepts of *applied science* and *design science* as a means of shifting the focus of science from explaining and interpreting the world into changing the world. He includes the creation of knowledge that has instrumental value in some specific (narrow) application as science. By emphasising the rigour of the research process he claims that the results of design science can be judged in terms of both epistemic and practical utilities.

Lately Holmström et al. (2009) have elaborated design science further, particularly in the context of operations management research. They identify an idiosyncrasy, in that basic research in the field of operations management is carried out by practitioners rather than academics. Consequently, they emphasise the creation of *artefacts* or solution designs as the central outcomes of research. They encourage the academics to utilise principles of design science and propose a four-phase approach including 1) solution incubation, 2) solution refinement, 3) explanation I – substantive theory, and 4) explanation II – formal theory.

Holmström et al. (2009) bring design science in operations management quite close to constructive research, though perhaps with even more focus on the solution creation phase. In their approach, a demonstration of a theoretical connection and contribution follows only after the solution creation, whereas in constructive research the theory connection is established before problem solving. In both cases the contribution to theory is evaluated afterwards.

Koskelo (2005, p. 14) provides a distinguished summary of the most common applicable research methods in management research. See Table 2.2.

2. Research methodology and design

Table 2.2. Characteristics of different possible research strategies.

GENERAL CHARACTERISTICS	WHEN TO USE?	ENSURING AND JUDGING THE QUALITY OF THE RESEARCH
Constructive research and design science		
<ul style="list-style-type: none"> • Normative in nature • Typically includes case studies • Both quantitative and qualitative methods can be used • Produces an innovative and theoretically grounded solution for a relevant problem • Uses a limited number of research objects 	<ul style="list-style-type: none"> • When there is a need for an innovative and theoretically grounded solution for a relevant problem • When there is a concern about "how things ought to be in order to attain goals" – not "how things are" 	<p>The research outcome:</p> <ul style="list-style-type: none"> • Relevant, simple and easy to use • Practical relevance • Practical utility • Useful • Theoretical novelty • Link to theory • Also applicable in other environments
Case study research		
<ul style="list-style-type: none"> • Descriptive or normative in nature • Both quantitative and qualitative methods used • Difficult to separate analysis and interpretation from data gathering • Analysis and interpreting subjective procedures • Knowledge constructed rather than discovered or found • Generalizing on the basis of a very limited number of cases • Generalizing is not making statistical inferences from the sample but to generalize through a deep understanding of the phenomena 	<ul style="list-style-type: none"> • When a contemporary phenomenon within its real life context needs investigation • To gain a better understanding of complex phenomena • When how and why questions are being asked about a set of events over which the investigator has little or no control • To build a theory and to test it 	<ul style="list-style-type: none"> • Use of triangulation • Proper research design • Rigorous and accurate representation of empirical data • Finding rival explanations • The reader is offered a chance independently to judge the merits, the validity, and reliability of the analysis
Action research		
<ul style="list-style-type: none"> • Field oriented • Researcher in addition to making research work uses the research results in developing the object • Close to the real phenomenon • Researcher's personal involvement • In full process: series of interconnected cycles with writing about research outcomes is important • Knowledge is constructed not discovered • Deep understanding of organizational processes is needed • Theory building as a result of action research 	<ul style="list-style-type: none"> • To describe an action or a development process of an organization. • The aim is to change the action of an organization. 	<ul style="list-style-type: none"> • The process of exploration of the data must be replicable or capable of being explained • Validity and applicability of the results: The history and context for the intervention must be included in the interpretation • Focusing on reflection and data collection processes • Triangulation

2.2 Scientific foresight studies and the Delphi method

Foresight, or the scientific study of the future, is nowhere near as well-established a branch of science as the natural sciences or even most of the social sciences. Debate continues whether forecasting the future is more of an art than a science. As Bell (1997, in Kuusi 1999, p. 1) points out, epistemic or philosophical foundations for future studies remain one of the least developed aspects in foresight. However, the philosophical foundations of future studies have been discussed by several distinguished researchers, e.g. by De Jouvenel (1967, in Kuusi 1999), Godet (1986, in Toivonen 2004), Mitroff and Turoff (in Linstone and Turoff 2002) and Kuusi (1999).

The possibilities of gaining objective knowledge about the future are limited. Quite often it is claimed that even the researchers themselves can have an impact on the decisions impacting the future. De Jouvenel (1967, in Kuusi 1999) explains this phenomenon: representations in the human mind are called “representations” because they represent fact, though (naturally) subjectively. Similarly, humans have the capacity to imagine representations of the future that serve as a source of systematic action. He presents four theses that illustrate this dependency:

1. Without representations of the future there would be no actions, only reactions. Often men act not “because...” but “in order to...”.
2. Sustained, systematic action aims at the validation of a representation projected into the future.
3. An assertion about the future only indicates an intention. The intensity of the intention, the mobilising of one's energy, is of great importance.
4. A man who acts with sustained intention to carry out a project is a creator of the future. The fact of one's presence in a specific place is (often) the consequence of one imagining his presence in that special place.

Therefore, any scientific foresight studies must accept and accommodate this inbuilt dependency, i.e. the motivations and decisions of the involved actors.

2.2.1 Popular typologies in scientific foresight studies

De Jouvenel makes a distinction between a primary forecast (something that is on-course to happen), a *secondary forecast* (a future that would result from deliberate action in order to impact the course of development) and a *tertiary forecast* (assuming that a third party will take specific action to impact the course of development). According to Kuusi (1999) this typology of forecasts can be considered the basis for the action theory of Godet (1994, in Kuusi 1999). Godet defines a number of basic concepts that are interesting from the point of view of the present study:

- *An Event* is an abstract Boolean entity (“1” or “0”); it either happens or does not.

2. Research methodology and design

- *Actors* are those with important roles with respect to future events; i.e. they have some control over it.
- A *Strategy* is each Actor's set of tactics that he/she plans to follow.
- A *Conflict* can result between Actors when their Strategies are in confrontation.
- An *Invariant* is a phenomenon that is assumed to be permanent up to the studied time horizon.
- A *Strong Trend* is something that causes development that is clearly predictable.
- A *Germ* (also known as a *Weak Signal*, addition by Kuusi 1999) is a factor of change that is hardly perceptible at present, but could become a Strong Trend in the future.
- *Randomness* is any event in the past or future concerning which we are incapable of verifying whether it took place or will take place.

Common to both De Jouvenel and Godet is the concept of "strategic prospective" (Godet) or "futurible" (De Jouvenel). Its meaning is a future state of affairs that is plausible and imaginable. It means there are facts supporting such a course of action that would sensibly imply such a future state of affairs; i.e. not only is such a future possible, but it is also desired by some parties who have the power to take such a course of action leading to such a future.

In her thesis Toivonen (2004, p. 132) introduces and operationalises the concept of *strong prospective trend* as a trend that is:

- identifiable on the basis of the development realised
- significant
- likely to continue at least for some time.

In order to qualify as a strong prospective trend a phenomenon has to be recognised rather uniformly by key experts in the field, who consider it significant and expect it to develop in a certain direction. Supporting evidence from earlier studies or historical development is also needed to meet the criteria for a strong prospective trend (Toivonen 2004, p. 132).

A trend is defined as the general direction found in the long-term development of the phenomenon studied (Rubin 2002 in Toivonen 2004, p. 7).

This study adopts the basic concepts of De Jouvenel, Godet, Rubin and Toivonen as described in Figure 2.3 (adapted from Toivonen, 2004). Strong prospective trends have a clear connection to past development and are widely supported by interpretations of the future within the expert community. These interpretations of the future can be institutional, but they sometimes combine significant weak signals leading to major turns in their direction of development; i.e. despite the required connection with a clearly observable development in the past, strong prospective trends need not be continuums of the past development. Weak signals can be classified based on their impact and likelihood of realisation, so that the significance equals their product.

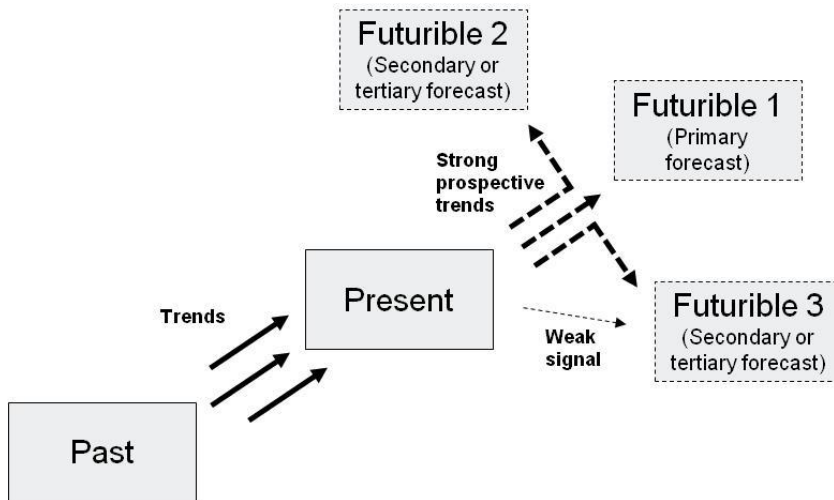

Figure 2.3. Summary of the applied foresight typology.

2.2.2 The Delphi method

Methods based on expert knowledge are typical foresight methods, although mathematical forecasting models have also been used. The Delphi method is perhaps the most well-established method or, more accurately, family of methods, based on expert knowledge. The Delphi method is in essence a panel of experts that interact anonymously in order to produce future intelligence. The panel is facilitated by the Delphi manager, i.e. usually the person conducting the research, who is responsible for accomplishing “structured communication” within the panel. Usually it includes some feedback on individual contributions of information and knowledge, some assessment of the group judgment or view, and some opportunity for individuals to revise their views. The composition of the panel is sometimes known, but individual comments and arguments are not connected with the panellists. This is designed to reduce authority problems associated with discussion on possible futures and the supporting arguments (Linstone and Mitroff 2002).

Usually, one or more of the following properties of an application lead to the need to employ Delphi (Linstone and Turoff, 2002):

- The problem does not lend itself to precise analytical techniques, but can benefit from subjective judgments on a collective basis.
- The individuals that are needed to contribute to the examination of a broad or complex problem have no history of adequate communication and may represent diverse backgrounds with respect to experience or expertise.
- More individuals are needed than can effectively interact in a face-to-face exchange.

2. Research methodology and design

- Time and cost make frequent group meetings infeasible.
- The efficiency of face-to-face meetings can be increased by a supplemental group communication process.
- Disagreements among individuals are so severe or politically unpalatable that the communication process must be refereed and/or anonymity assured.
- The heterogeneity of the participants must be preserved to ensure the validity of the results; i.e., avoidance of domination by quantity or by strength of personality (“bandwagon effect”).

The third, fourth and fifth bullet points listed by Linstone and Turoff can be criticized for their assumption that anonymity in communications within the Delphi panel could be sacrificed. Typically, anonymity in communication, combined with active and neutral management of the panel, is the very feature that makes the whole process so successful in generating new and balanced foresight (interview of Kuusi 2011).

For the purposes of this study, there was a need for expert opinion to be generated on RCF market development, and so the Delphi method was selected due simply to its reputation as a widely adopted method of generating foresight based on expert knowledge. Several foresight studies have lately been carried out in Finland by successfully applying Delphi (e.g. Toivonen 2004, Kuusi 1994 and 2006, Tapio 2002, Myllylä 2007).

The philosophical and methodological foundations of the Delphi method are provided by e.g. Mitroff and Turoff (in Linstone and Turoff 2002, pp. 17–34). There are in fact many philosophical approaches to the question of validity. Linstone and Turoff discuss how the Delphi method can be interpreted in the light of the Lockean Inquiry System (IS), Leibnizian IS, Kantian IS, Hegelian IS and Singerian-Churmann IS. They argue that a valid Delphi process can be constructed based on different philosophical foundations, but often Delphi benefits from the broadest possible modelling of any inquirer or problem. While the Lockean consensus-oriented Delphi may be appropriate for purely technological forecasting, it lacks tools to explore or generate alternatives. In practice this would require e.g. involving heterogeneous group of panellists with different backgrounds, aiming to build alternative *futuribles*, and building-in conflictual set-ups in the IS, etc.

In his dissertation of 1999 Kuusi discusses extensively the epistemic foundations of futures research. He defends its position as science rather than art by e.g. defining a concept of “anticipatory rationale” instead of purely irrational anticipation. “Though it is not possible to present empirical truths concerning the future, it is possible to find truthful arguments concerning the future. A possible scientific endeavour may be to increase the validity of future relevant arguments.” (Kuusi 1999, p. 12).

One way of classifying future studies based on their type of reasonability argumentation, i.e. the purpose of the study, is presented by Kuusi (1999, pp. 115–121) as follows:

- Predictive reasonability: the focus of arguments and judgements is on anticipation of the actions of relevant actors, i.e. without trying to impact their behaviour.
- Option reasonability: the focus is on obtaining argumentation and judgements on options that are important and valid, at least for some actors represented in the panel. It would be desirable to identify options that are new for the actors represented in the panel.
- Commitment reasonability: the focus is on building coalitions of actors for realizing future options. E.g., the target could be to identify the best plan among several candidates, and to commit the actors to realising that plan.

This classification should be reflected in the choice and design of the Delphi procedures. For the purposes of the present study, the main target is to generate predictive reasonability without specifically trying to impact the behaviour of the relevant actors. However, in order to create the practical utility targeted in this study, option reasonability is also relevant and needs to be reflected in the research design.

Yet one obvious question arises when setting up a Delphi panel – “Who is an expert?” Kuusi presents a valuable classification of basic types of expert knowledge about the future. See Table 2.3 (Kuusi 1999, p. 36). In his dissertation this classification is justified against the general theory of consistency. According to Godet (1994) invariances are phenomena that are considered permanent in the time horizon of the study. Kuusi further splits the invariances into permanent invariances and transient invariances that relate to habits, routines and equilibrium points of learning actors, i.e. things that might state when the boundary conditions change. Scientists possess a knowledge of invariances. Decision makers are actors who have significant control over resources, capabilities and capacities and who have defined interests. Synthesizers have the ability to identify the relevance of all the mentioned factors.

Table 2.3. Types of experts about the future.

Type of expert	Types of expertise
Scientists	<ul style="list-style-type: none"> ▪ Knowledge on invariances: <ul style="list-style-type: none"> - permanent invariances - transient invariances
Decision-makers	<ul style="list-style-type: none"> ▪ Real and perceived capacity limits; ▪ Perceived interests and routines; ▪ Real and perceived capability limits
Synthesizers	<ul style="list-style-type: none"> ▪ Relevant invariances ▪ Relevant capacity limits ▪ Relevant interests ▪ Relevant capability limits

A potential set-up of a Delphi panel for gaining foresight into the supply-demand behaviour of RCF necessitates an analysis of various trends related to supply, demand, prices, etc. According to Kuusi (interviews and correspondence in 2010), the panel in a Trend Delphi should include at least scientists who are capable of analysing the reasons leading to the development of a given trend. *Futuribles* can then be assessed, knowing whether the factors that enabled the given trend are still in place. However, the continuation of a given trend is often connected to new emerging possibilities such as the adaptation of new technology. Such continuation is also often clearly connected to the will of key players to pursue it. Therefore, it is recommended that the panel include representatives of different (even opposing) interest groups. Synthesizers are less necessary on the panel in Trend Delphi than in Policy Delphi or Cross-impact Delphi. However, synthesizers are undoubtedly needed to interpret the results (Kuusi, interviews and correspondence in 2010).

2.3 Selected research strategy

Unlike most studies in the field of business economics or management, the object of this research is not an organisation, but a market system where related industries find themselves in very dynamic conditions. The econometrics that is typically used to analyse the market behaviour of commodities, including recovered paper, is based on comprehensive statistics of market volumes and prices for substituting and complementing the factors of production. It is likely to be prone to more fundamental shifts in market conditions, and consequently incapable of shedding light on more radical changes in the market, not to mention outlining wider qualitative future scenarios, as are called for in this research. Thus, while qualitative aspects will be central in this study, the application of previous findings from the econometric analysis of the recovered paper market will play an important role in a number of sub-tasks in this research.

To improve the qualitative understanding of the RCF market, and thus be able to meet the research objectives, it might well become necessary to construct a new model that is able to describe the phenomena that take place on the composite recycled fibre market. Therefore *constructive research* has been selected as the main approach. It provides the backbone for the whole study, while the handling and collecting of evidence for specific sub-tasks will require various descriptive means, as well as means related to the scientific study of the future. This choice is in agreement with e.g. Eisenhardt's findings that qualitative and quantitative traditions actually support each other (1989, p. 538).

According to Kasanen, constructive research can be used in situations where there is a need for a practical solution to an existing problem. In our case, the practical problem is to understand the interplay of different markets utilising discarded-paper-containing waste flows. The solution must be based on need, and must be connected to existing theoretical knowledge. In addition, its usefulness and usability, as well as its theoretical novelty, must be shown (Kasanen et al. 1993).

Although the case study method is known to be suitable for studying research problems that focus on why and how questions, as in this study, it was excluded simply because it did not seem practical to acquire data for the purposes of this research by studying cases in the manner proposed by e.g. Yin (1989 in Koskelo 2005). In the case of this research, the data and evidence have been collected mainly by interviews, by market observations and from the literature, including the body of knowledge in the relevant econometric analyses. With respect to other research methods, *action research* seemed to lack an emphasis on discovery and problem solving by the creation of new models, constructs or artefacts. However, suitable alternatives to Kasanen's constructive research method could have been found from other methods of *applied science*, such as *design science*. In recent work by Holmström et al. (2009) design science has been elaborated from the perspective of operations management research, and their examples of how the research might be conducted mainly involve typical problems in production and supply chain planning. Constructive research as proposed by Kasanen et al. (1993) appealed to me the most because of its more established structure and its consequent ease-of-use as a backbone for the research.

For the purposes of scientific research it is necessary to break the research objectives down further, into specific research questions. This breakdown is given in Table 2.4.

Table 2.4. Research questions.

Research objective	Research questions
i) Confirm the relevance of the research issue and establish criteria for suitable tools and theories in the study of the RCF market	Q1: Is there a need for a model of the composite RCF market?
	Q2: What are the criteria for the model of the composite RCF market?
ii) Identify suitable theories that can be used to study how the market deals with competing demands	Q3: Are there pre-existing theoretical models that satisfactorily meet the need to understand the composite RCF market?
iii) Construct a model of the composite RCF market	Q4: What does the model of the composite RCF market look like?
iv) Gain foresight of the phenomena that are likely to take place on the RCF market	Q5: What phenomena are the likely to affect the RCF market in the future?
	Q6: Are any such market phenomena likely in the future that might suggest increasing interplay between the markets for the use of discarded-paper-containing flows as raw material and as fuel?
v) Jointly apply the model and the achieved foresight – what is likely to happen on the RCF market	Q7: What are the main and alternative scenarios for the future development of the RCF market?
	Q8: Can the scenarios and the conditions under which they will be realised be meaningfully quantified by using the constructed model?
vi) Evaluate the epistemic and practical utility of the results and research approach	Q9: Are there analogical problems where the combination of the proposed composite market model and scientific foresight are applicable and useful?

The research questions Q1–Q2 handle the aspect of practical need in the spirit of *constructive research*. The whole question of whether the pre-observed need for a new model is true, and whether any of the pre-existing models or theories could not provide answers to the kind of questions raised in Chapter 1 of this study needs first to be dealt with. In this study the research question Q3 literally handles the theory connection.

Constructive research aims to create an innovative solution to the problem, test the solution empirically, and consider the scope of applicability of this construct (Kasanen et al. 1993, p. 257). The construction of the model – the problem solving part of constructive research – is manifested by the research question Q4. The new construct is expected to be a market model explaining the interplay between different markets for different RCF-containing material flows. The research questions Q5-Q8 handle the testing (and further refining and iteration) of the construct, and should reveal its practical functioning: i.e. can a composite model of the RCF market provide meaningful insight into market development. Finally, Q9 seeks an answer to the theoretical and practical contribution of the new construct.

2.4 Research design

This study combines methods from several schools of research. The main structure of the study follows constructive research in the sense that it presents a new type of a model for the composite RCF market – *a new construct* based on a confirmed need and criteria for such a model. On the other hand, the model of the composite RCF market relies on very basic theories in economics and has been influenced by some contemporary research in mainstream econometric analysis. Last, but not least, this research belongs to the school of scientific foresight studies, in the sense that it employs the widely used Delphi methodology in three important respects: 1) to gain support and insight necessary for crafting a general composite model of the RCF market in highly iterative manner, 2) to identify important trends affecting the composite RCF market, 3) to present quantified forecasts on how these trends are likely to develop.

Figure 2.4 provides an overview of phases of the research. It should be read together with Table 2.5 that summarises the research methods used in the study. The feedback and ideas received from the Delphi panellists regarding the S/D model under construction proved instrumental in the process.

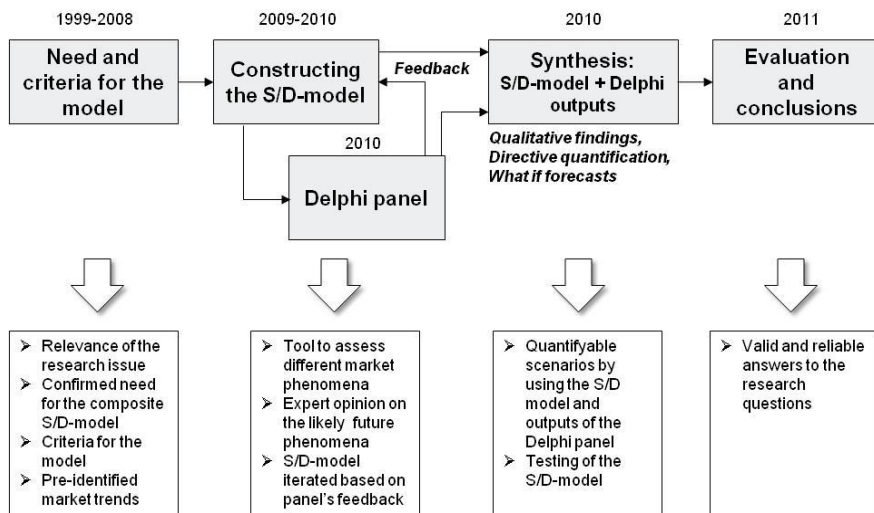

Figure 2.4. Phases of the research.

2. Research methodology and design

Table 2.5. The research methods, research materials and data sources employed in the study.

Research question	Method	Materials / data sources
Q1: Is there a need for a model of the composite RCF market?	Literature study, narratives of topical developments of interest and their financial analysis	Scientific literature, news in trade press, expert interviews, mass balances and cost data from the involved research teams
Q2: What are the criteria for the model of the composite RCF market?	As above	As above
Q3: Are there pre-existing theoretical models that satisfactorily meet the need to understand the composite RCF market?	Literature study	Scientific literature in the field of econometric analysis
Q4: What does the model of the composite RCF market look like?	Iterative construction of the model in connection with the Delphi-panel	Scientific literature (reported own-price and cross-price elasticities), expert interviews, market data and observations, Delphi-panel
Q5: What phenomena are the likely to affect the RCF market in the future?	Scientific foresight / Delphi	3-round Delphi-panel consisting of: semi-structured interviews, trend extrapolations, 1st round report and structured questionnaire, 2nd round report, final feedback by panelists
Q6: Are any such market phenomena likely in the future that might suggest increasing interplay between the markets for the use of discarded-paper-containing flows as raw material and as fuel?	Scientific foresight / Delphi	As above
Q7: What are the main and alternative scenarios for the future development of the RCF market?	Testing and iterating the constructed model	Outputs of the Delphi-study, market data and observations, literature
Q8: Can the scenarios and the conditions under which they will be realised be meaningfully quantified by using the constructed model?	Testing and iterating the constructed model	As above
Q9: Are there analogical problems where the combination of the proposed composite market model and scientific foresight are applicable and useful?	Desktop study	Scientific literature, expert interviews

Lanning (2001, p. 57) summarises the strengths and weaknesses of different sources of evidence (Table 2.6). Considering the methods and materials of this research as presented in Table 2.5, the main potential shortcomings of this research might relate to different biases inherent in the interviews and questionnaires. In the context of studies of the future, these become even more pronounced. These will be discussed in more detail under Chapter 7, Evaluation of the Research.

Table 2.6. Strengths and weaknesses of different sources of evidence.

Source of evidence	Strengths	Weaknesses
Documentation	<ul style="list-style-type: none"> ▪ Stable – can be reviewed repeatedly ▪ Unobstructive – not created as a result of a case study ▪ Exact – contains exact names, references and details of an event ▪ Broad coverage – long span of time many events and many settings 	<ul style="list-style-type: none"> ▪ Retrievability – can be low ▪ Biased selectivity, if collection is incomplete ▪ Reporting bias – reflects (unknown) bias of author ▪ Access – may be deliberately blocked
Interviews and questionnaires	<ul style="list-style-type: none"> ▪ Targeted – focused directly on case study topic ▪ Insightful – provides perceived causal inferences 	<ul style="list-style-type: none"> ▪ Bias due to poorly constructed questions ▪ Response bias ▪ Inaccuracies due to poor recall ▪ Reflexivity – interviewee gives what interviewer wants to hear
Observation	<ul style="list-style-type: none"> ▪ Reality – covers events in real time ▪ Contextual – covers context of events ▪ Insightful into interpersonal behavior and motives (in participant observation) 	<ul style="list-style-type: none"> ▪ Time-consuming ▪ Selectivity – unless broad coverage ▪ Reflexivity – event may proceed differently because it is being observed ▪ Cost – hours needed by human observers ▪ Bias due to investigator's manipulation of events (in participant observation)

The more detailed design of the Delphi study performed as a central part of this research is given in Chapter 5 of this report, i.e. in connection with reporting its findings.

In terms of answering the research questions, the rest of the report structure is as follows:

- Chapter 3: Pre-identification of market trends answers the research questions Q1–Q2.
- Chapter 4: The composite S/D model of the RCF market answers Q3–Q4.
- Chapter 5: The Delphi study on supply-demand behaviour of RCF answers Q5–Q6.
- Chapter 6: Synthesis of the S/D model and Delphi outputs answers Q7–Q8.
- Chapter 7: Evaluation of the research will provide the answer to Q9.

3. Pre-identification of market trends – need and criteria for the model

The objective of this chapter is to define answers to the following research questions:

Q1: Is there a need for a model of the composite RCF market?

And if yes:

Q2: What are the criteria for the model of the composite RCF market?

This chapter answers these research questions by discussing various market evidence and a few pre-identified trends relevant to the research issue¹³. These will highlight the need and criteria for a model of the composite RCF market. In terms of *constructive research* this chapter summarises and confirms the *practical relevance* of the research (Kasanen et al. 1993, p. 246). The pre-identified trends are analysed using the typology of scientific foresight as defined in Chapter 2.3 and Figure 2.2.

3.1 RCF as a source of competitiveness: the case of US mini-mills

3.1.1 Background: economies of scale

While economies of scale are important in practically any industry, they have always been exceptionally strong in the capital-intensive P&P industry. Therefore the unit size of new production assets has continuously increased (Diesen 1998a), which has brought clear benefits in both capex and opex. Many of the process technologies required by paper production can be sourced at lower specific cost (capex/t) as the unit size grows. This has been made possible mainly by technical development of the bottleneck in the process – the paper machine – with the ad-

¹³ All narratives in this Chapter are related to the author's previous practical and research endeavours in the field, encompassing a period of approximately 10 years, i.e. 1999–2008. They can be considered to form a synopsis of the author's *pre-understanding* that sparked his interest in the *research issue*.

vance of R&D in recent decades. Personnel costs and many types of overheads in the paper mill are only weakly connected to the volume of production, and are thus essentially of a fixed nature. Therefore, opex/t also declines considerably with an increase in unit size. Transportation costs and the interest on tied-up working capital usually increase with unit size, but, so far, this has not cancelled out the gains in capex and fixed costs (Diesen 1998a, Ristola 1999).

There were a few exceptions in the past, when the rule of always maximising the economies of scale was by-passed, and the driving force in dimensioning new production capacity was something else. In such cases there was always another factor bringing significant relative advantage vis-à-vis the competition, such as an exceptionally low variable cost base.¹⁴ An example of such was the case of so-called urban mini-mills¹⁵ in the United States, where the tapping of the recycled fibre potential of the urban areas played a central role.

3.1.2 Success story of mini-mills

The urban mini-mill is a production concept that showcased the power of RCF to change the structure of production assets within a major sub-segment of the P&P industry. While RCF had already played a major role in the production of case materials¹⁶ in Europe throughout the 20th century, the structure of production assets remained very different in the US right up to the 1990s. In the US, linerboard mills had traditionally been built away from the areas of consumption, next to the kraft pulp mills that provided them with high-strength virgin fibre and the low-cost steam and electricity that was produced as a by-product of chemical pulping. By 1990, only two of about 40 US linerboard mills were RCP-based (Jacobs Sirrinc 1999, JP SmartTerminal, data retrieved in 2011). In the 1990s several companies, some of them box manufacturers planning up-stream integration, realised that ample raw material potential existed in the form of high-quality OCC, available close to the areas of consumption. As a result, roughly a dozen board mills that had much less than state-of-the-art capacity mushroomed in the urban areas,

¹⁴ The reader should note that every investment project must have a good fit with several critical success factors, such as a market for the end products, the availability of raw materials at competitive costs, inexpensive utilities, skilled personnel, etc. However, in past investments in the production of bulk paper or board grades, there has usually been very few exceptions to the rule of always building paper machines with state-of-the-art capacity; i.e. the investment project has usually been selected so that there are no other constraints limiting unit size (Diesen 1998b).

¹⁵ The term 'mini-mill' or 'urban mini-mill' has been used by the P&P industry to describe a smaller production unit, built to meet a more local demand in its urban neighbourhood with a product that is usually 100% based on recycled fibre. This means that the raw material is also typically attainable from the local urban neighbourhood (e.g. Young et al. 1993, Ristola and Karlsson 2000).

¹⁶ Case materials refer to linerboard and corrugating medium (fluting or *wellenstoff*). These are the components needed in producing the sandwich structure of a corrugated container.

3. Pre-identification of market trends – need and criteria for the model

often run by companies integrated with box-making. See Figure 3.1 (trade press information, Pöyry SmartTerminal, data retrieved in 2009).

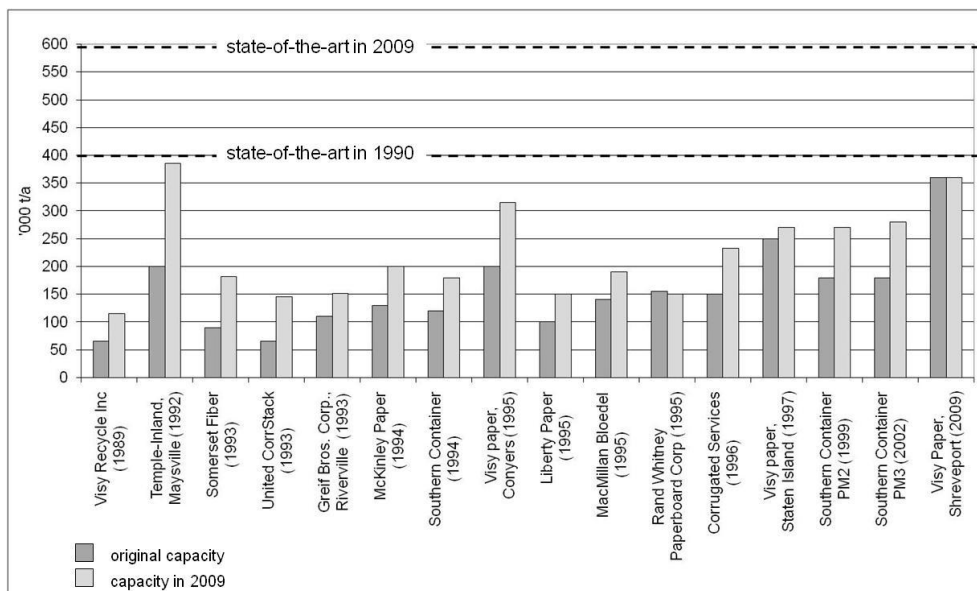

Figure 3.1. US mini-mills producing case materials, by start-up year.

In the 5-year period, 1992–1996, 17 new paper machines producing containerboard grades started up in North America. Of these, 11 can be classified as mini-mills (included in Figure 3.1 above). Five of the six remaining machines were also based on RCF, but were built as part of pre-existing integrates producing kraft pulp. Only one of the 17 US machines built in 1992–1996 was based on virgin fibre (International Paper Campti, 1995), and it still remains the latest 100% virgin-fibre-based containerboard machine in the world. All of the machines listed in Figure 3.1 were still operational in 2009 and many of them had considerably increased their capacity since the start-up (Pöyry SmartTerminal, data retrieved in 2009).

The competitiveness of the urban mini-mills was reported to be based not only on the advantageous supply of waste paper raw material, but also on the relatively low inbound and outbound logistics cost (e.g. Young et al. 1993). Despite the obvious disadvantages of smaller scale, there were some other factors that helped to keep capex/t low enough compared with the competition. They included reliance on purchased energy and effluent treatment, and, perhaps more importantly, the concept of building a ‘lean mill’ without expansion plans (Young et al. 1993, Schultz 1995, Koepnick 1995, Ristola 1999). This gave several process-dimensioning, mill layout and construction-related advantages that helped the mini-mill investors to hold back the increases in capex/t. Furthermore, regarding fixed costs, these small greenfield mills had certain advantages allowing them to

(partly) compensate their smaller unit size. For example, the mini-mill newcomers successfully used a team approach to cut personnel costs (Young et al. 1993, Schultz 1995, Koepnick 1995).

It is difficult to be fully objective in judging whether the tapping of the urban RCF potential has been the only factor promoting mini-mill success in the US, but most likely it has been the dominant one. The market evidence, i.e. the fact that nobody has built a virgin-fibre-based paper machine producing case materials since 1995, is perhaps the strongest argument. RCF provided these mini-mills with a cost advantage over the virgin-pulp-based competition in both opex and capex. The above-mentioned other advantages in capex and opex are more related to minimising the growth in capex/t and opex/t due to smaller size. Another fact supporting this conclusion is that many of the remote integrates that earlier produced 100% kraft linerboard switched partly to RCF in the wake of the mini-mills (e.g. Georgia-Pacific at Big Island in 1996, International Paper at Mansfield in 1995, Weyerhaeuser at Cedar Rapids in 1995, Smurfit-Stone at Stevenson in 1996). A second argument supporting the decisive role of RCF in the US mini-mill boom is that, despite many efforts, similar advantages were never realised anywhere else in the world. The likely explanation is that similar advantages from switching to RCF were not available elsewhere, as the majority of the relevant capacity was already RCF-based.

Combining the case of the US mini-mills with the historical development in RCF utilisation (Figure 1.1), we can conclude that the competitive advantage of RCF over virgin fibre appears to be a candidate for a ***strong prospective trend*** in the P&P industry and might even be considered a ***transient invariance***, as defined by Kuusi (1999). The competitive advantage of RCF today seems to be embedded in the routines and equilibrium points of industry actors, though this state of affairs obviously *can change*, if the boundary conditions change.

3.2 Integration with waste-to-energy

As outlined in Chapter 1 (e.g. Table 1.1), there appears to be an on-going trend of integrating waste-to-energy operations at RCF-based paper mills in parts of Europe. At the end of the 1990s a research team at Metso (formerly Valmet) led by the author of this study began to investigate future steps related to the urban mini-mill concept. It was quickly concluded that the use of local RCF alone was not enough to give any competitive advantage over the regular investment strategy of maximising the unit size, because RCF had already established itself as the most competitive raw material¹⁷. The research continued along the lines of “industrial symbiosis” or “industrial ecology” – i.e. how the paper mill could be built to best

¹⁷ For those grades that had a technical fit with RCF utilisation in the first place (i.e. mainly newsprint and case materials). These two grades cover 40–45% of the global papermaking capacity.

3. Pre-identification of market trends – need and criteria for the model

benefit from the infrastructure likely to be found in urban brownfield settings. In this analysis waste-to-energy (W-t-E) was identified as the operation with the most synergistic potential.

The synergistic fit of waste-to-energy and RCF-based papermaking is based on the following simple reasoning:

- The efficiency of W-t-E in power generation is inherently low because contaminants in the fuel limit the availability of the plant, as well as the steam temperature and pressure, yielding energy efficiencies in the range of 20–30% at best (see Vesanto 2006).
- Because of the limitations concerning steam pressure with waste fuels, combined heat and power (CHP) is a perfect concept for W-t-E – given that a major industrial user for the heat can be found and that the reliability of the W-t-E operations is at a high enough level.
- Even a relatively small paper mill is a major year-round, 24/7 customer for the process steam and electricity, enabling a W-t-E power plant to achieve 80–90% total efficiency in its energy conversion.
- RCF-based papermaking needs to dispose of a significant amount of relatively high calorific reject and, in the case of de-inking operations, also a high amount of low-calorific, high-ash-containing sludge that can be treated at e.g. modern fluidised bed W-t-E boilers.

The availability of modern W-t-E operations has reached a level where the neighbouring paper mill must use back-up systems to generate its energy needs only during short periods. It could mean less than 5% of annual operation time (see Makkonen and Hotta 2002). This has been made possible by, on the one hand, development of fluidised bed boilers and, on the other hand, improvements in the pre-treatment systems for combustible waste. A modern set-up in RDF production includes size reduction (crushing) and various screening operations to improve the fuel properties and processability of the waste fuel. It has long been known that fluidised bed technology is suitable for the combustion of fuels with highly varying solids contents (Ristola 1973), such as the rejects and de-inking sludges of paper mills.

The author claimed as far back as 2000 (Ristola and Karlsson 2000) that modern RDF-based W-t-E and RCF-based papermaking form a solid companionship. Ten years later, this has been recognised by the market, especially in Germany, as can be seen from Table 3.1 (based on trade press information and company releases on their internet pages).

Table 3.1. Examples of Waste-to-Energy boilers at paper mills in operation or under construction.

Paper mill	Country	Boiler MW	Fuel	Operator	Start-up
StoraEnso Varkaus	FI	50	Residues, gasifier	StoraEnso	2001
SCA Witzenhausen	GE	124	Residues + 265 ktpa RDF	SCA	2008
Sonoco Karhula	FI	35	MSW, 87 ktpa	Kotkan Energia	2008
Palm Wörth	GE	54	Residues + combi-cycle		2008
Klingele Weener	GE	70	140 ktpa RDF	Prokon Nord	2008
Jass Rudolfstadt Schwarza	GE	~30	RDF, 60 ktpa		2008
Hürth-Knapsack	GE	~120	Residues + RDF, 240 kt/a	E.On	2009
Leipa Schwedt	GE	136	Residues + max 220 kt/a of RDF	E.On	2010
Propapier, Eisenhüttenstadt	GE	150	Residues + 250 ktpa RDF + coal	EnBW	2010
StoraEnso Langerbrügge	BE	125	Residues + RDF + PDF	StoraEnso	2010
StoraEnso Maxau	GE	155	Residues + biofuel + PDF + coal, 210 ktpa	StoraEnso	2010
Steinbeis Temming, Glückstadt	GE	?	Residues + RDF	Steinbeis	2010
Hamburger, Spremberg	GE	~120	Residues + RDF, 250 kt/a	Hamburger	2012

The boilers listed in Table 3.1 represent a combined thermal capacity of some 1.3 GW which in turn converts to 2–2.5 million tons of RDF / biofuels per annum. Through investments such as these, the competition for suitable waste fuels has already started and the price of such fuels has turned positive (interview of Hietanen 2011). The total market potential in Germany alone is estimated to range between 26–36 units, covering up to 6 Mt/a of SRF. This result, based on national waste statistics, was cross-checked against detailed waste and plant data for Baden-Württemberg and resulted in a potential of seven units and 1.1 Mt/a. Interestingly, six of the seven feasible boiler locations identified were at paper mill sites (Sipilä et al. 2009).

At least regionally, in Central Europe, investing in modern, efficient W-t-E boilers based on RDF, SRF or similar fuels at RCF-based paper mills appears to be a **Trend** based on the definitions adopted in Chapter 2. It can be assumed to cause the following predictable development on the market:

- increasing demand for high-quality, refuse-derived fuels
- increasing price for high-quality, refuse-derived fuels
- improving the competitiveness of RCF-based paper mills and thus increasing their paying capability for RCP¹⁸.

¹⁸ In practice, of course, this might coincide with other factors hampering the industry's capability to pay for RCP, but should have the indicated consequence, if all other things are equal.

If it turns out that experts widely agree that this trend is likely to continue and also spread outside Germany in the future, it would need to be classified as a ***strong prospective trend***.

3.3 Possible next steps for applying W-t-E at paper mills

The on-going trend of investing in solid fuel boilers that are capable of utilising a mixture of rejects, RDF and biofuels at paper mills can perhaps be boosted by new technologies currently under development. Two such examples are elaborated below.

3.3.1 Waste as a dual source of fibre and fuel

In the research by Metso, it was found that typical RDF included a significant amount (approximately 40–50%) of discarded paper that was technically usable in manufacturing recycled case materials (Ristola 2004a). Thus, a central idea that emerged in Metso's research was that such urban solid waste flows containing a combined high content of discarded paper and other combustibles were typical, and that, by using a relatively simple process, such material could be converted into fibre slurry useful for paper production and into fuel fractions useful for integrated CHP production. In several publications of the author, these concepts have been referred to as the 'Urban Mill' (Ristola and Karlsson 2000, Ristola 2004a, Ristola and Mirata 2007).

In extensive pilot trials by Metso, more than 500 tons of waste material were processed into two main components: a fibre slurry, and intensively washed, plastics-rich reject. The fibre slurry was demonstrated to be perfectly usable in the production of core board at Sonoco's (formerly Ahlstrom's) core board mill at Karhula, Finland. The dosing of fibre from the waste was tested up to a level of 35% and it performed up to expectations (Ristola 2004a).

Most of the raw material for the pilot trials was RDF produced from the mixed waste of households and commerce in the Forssa region of southern Finland. Figure 3.2 illustrates a typical mass balance of the trials (Ristola 2004a). The average fibre yield for the paper machine was 35% of the household-based RDF feed. The coarse reject approximated 50%, with the remaining 15% being formed by the screening reject necessary to remove small non-fibrous contaminants from the pulp and by a few smaller flows. Later, roughly similar results were reported by Hietanen (2009).

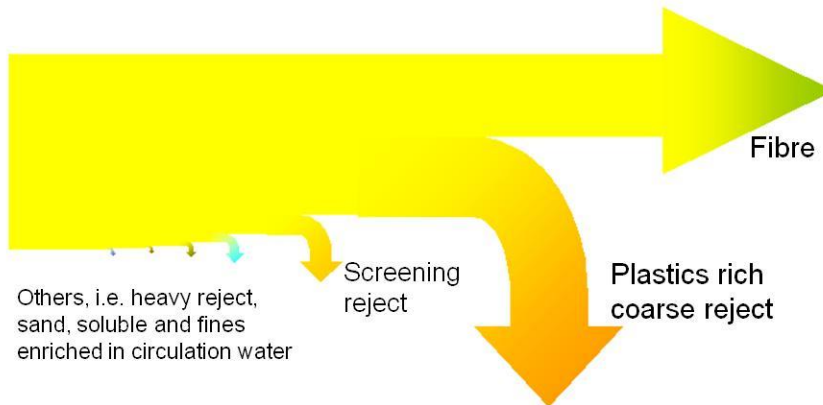

Figure 3.2. Typical Sankey diagram of waste material processed at the Karhula trials.

The material composition and fuel properties of the main reject flows were thoroughly analysed and found to be suitable for use as a substitute for RDF. The optimal treatment of the coarse reject depends on the intended power plant concept and the reject's share in the fuel mix.

The Karhula trials demonstrated that the RDF type of waste can technically be utilised as a **dual source** of fibre and fuel. Somewhat ironically, the main problem encountered in developing the first commercial plant in Finland was insufficient economies of scale for the concept to provide enough payback in the Finnish context. The analysis revealed that it would require a minimum of 50,000 tons of waste fibre to be utilised annually in order for the operations to be profitable. Figure 3.3 presents one potentially feasible application of the concept – a paper mill situated next to an existing (municipal) coal-fired CHP power plant that supplies the paper mill with its heat and power needs and uses the paper mill's rejects as its fuel (Ristola and Mirata 2007).

3. Pre-identification of market trends – need and criteria for the model

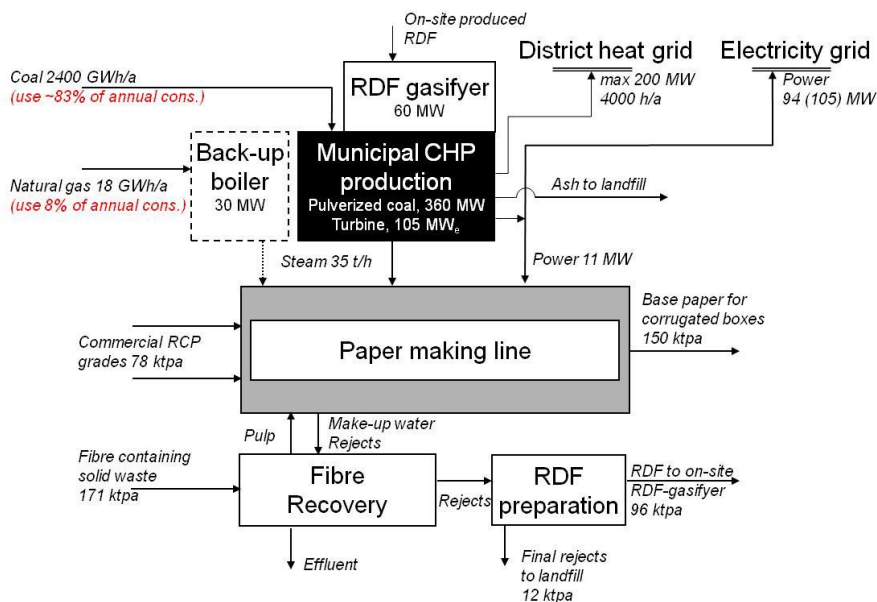

Figure 3.3. Mass balance of a 150,000 t/y Urban Mill integrated with a neighbouring CHP plant.

A serious complication in utilising waste as a dual source of fibre and fuel is the undefined origin of the raw material. Within the EU much effort has been put into defining requirements for the raw materials allowed to be in contact with food. The use of recycled fibre is allowed in case materials only if its origin is controlled (EC Public Health Committee 2007).

This requirement complicates the use of waste as a dual source of fibre and fuel in the production of case materials. In practice a producer of case materials must limit itself in Europe to such waste streams that are not true MSW streams. Such materials could perhaps include source-controlled CIW or industrial mono-streams with plastics-fibre composite structures. If no solution is found for applicability of the concept in the production of case materials, the MSW-based applications of the concept will in practice be limited to coreboards and perhaps marginally to liner for plasterboards. Hietanen (2009, pp. 81–85) is a bit more optimistic about the applicability of the fibres separated from CIW in fluting.

Interestingly, the food contact theme of RCF heated up again in 2009–2010 with the so-called “mineral-oil crisis”. The migration of mineral-oil-saturated and aromatic hydrocarbons from packaging into foodstuffs has recently been found to exceed the limit values set by European legislation (Kersten et al. 2011). After extensive debate, industry and the research community have come to the conclusion that relatively strict actions will be needed in the future to ensure low levels of migration into packaged foodstuffs. The actions identified include the increased use of virgin fibre, stricter control over RCP quality and the use of additional inner-

packaging with barrier functions (Kersten et al. 2011). Over time, this development could lead to fairly large changes in the use of RCP – something that simply cannot happen overnight, as RCP-based products presently account for more than a half of cartonboard consumption in Europe (Pöyry SmartTerminal, data retrieved in 2011). Any eventual large-scale reactions to the mineral oil crisis are considered to be a **weak signal** candidate in this study¹⁹.

The concept of the Urban Mill, i.e. the utilisation of miscellaneous discarded-paper-containing waste flows as a dual source of fibre and fuel, could perhaps already be considered as a **weak signal** candidate. There are presently hardly any installations working according to this principle²⁰, but the main preconditions required for such development are coming into place. The large-scale use of waste as a dual source requires qualified boiler capacity, preferably on-site and serving the power and steam needs of the paper mill. Now, almost ten years after introduction of the concept, this development is materialising in Europe. It means that after start-up of large-scale RDF boiler capacity at various mills, there will be a sink for the potential increased amount of non-fibrous components in the raw material. This will inevitably open up various opportunities to introduce new flows for utilisation in paper, whether it be composite materials or pre-treated MSW (RDF). At least in the future we are likely to witness increasing use of various low-yield RCP fractions.

3.3.2 Recycled-fibre-based bioethanol

Background: renewable fuels for transportation

One of the dominant themes in the global economic and political discussions of the 2000s has certainly been the happy mix of climate change, reduction of CO₂ emissions, skyrocketing oil prices, renewable energy and the breaking of industrial economies' dependence on fossil fuels. This has affected the global P&P industry in various ways. Firstly, the cost of energy and many of the oil-based raw materials and additives has been on the rise. Secondly, high hopes have been placed on the role of biomass-based energy. In general this is expected to increase the price of wood. (See e.g. Stichting Bos en Hout 2000, Mantau et al. 2010.)

When we talk about breaking the industrial economies' dependence on oil, the most critical issue seems to be the ever increasing need for transportation fuels.

¹⁹ This finding was in fact published after the Delphi study of this research and thus did not come up in the foresight process. This factor is included in the discussion of "post-delphi" factors, section 6.3.3.

²⁰ Early attempts to construct and operate RCF lines tolerating a high non-fibrous percentage have been reported by Menges (1992) and Mäkipaja (1998). The described installations have mainly focused on processing used beverage cartons that typically contain 20–30% non-fibrous material and their results are thus not directly applicable to processing the waste flows described in this narrative.

Several very powerful policy measures have already been adopted by EU governments (e.g. 2009/28/EC) to support the development and sale of renewable transportation fuels, namely biomass-based diesel and ethanol (EtOH). By summing the country-specific targets for 2020 from the EU's national renewable energy action plans (European Commission 2011) one gets a target of more than 12 million m³ of EtOH, of which 10% should be 2nd generation cellulosic ethanol. More than 50% of the total is still expected to be imported ethanol by 2020. In the US, the target for the renewable component in transportation fuels by 2022 is set at 136 million m³ (US EPA 2011). Cellulosic ethanol is expected to cover about half of this total.

In order to avoid expensive investments in the distribution system, the aim is simply to blend gradually increasing amounts of biodiesel and ethanol into regular diesel and gasoline respectively. The state-of-the-art in biodiesel was for long FAME²¹ based on e.g. rape seed or sunflower seed. In the 2000s the Finnish company Neste Oil introduced a new 2nd generation process (NExBTL) based on hydrogen treatment and which is capable of producing a 100% substitute for mineral-oil-based diesel from bio-oils (vegetable oils and animal fat). On the ethanol side, the state-of-the-art has clearly been tropical sugar-cane-based ethanol. In the European context, wine-based ethanol has been produced in smallish quantities as a side plot to EU agricultural subsidies, but distilling ethanol from surplus wine has no significance in the big picture due to its small amounts (Östman et al. 2005, Juva 2008).

Ligno-cellulose (wood) has long been recognised as one of the most potential feedstocks for biomass-based ethanol (Östman et al. 2005, Juva 2008). It is relatively inexpensive to harvest (in comparison to many agro-crops, whose cultivation and harvesting consumes almost as much fossil fuel as that saved by using the ethanol produced from those crops) and is available in good volumes. The bad news is that it is difficult to convert the sugar of ligno-cellulose with today's technologies. After harvesting and chipping it needs extensive pretreatment to produce polymeric sugars, acidic or enzymatic hydrolysis into short sugars, fermentation and finally distillation (Hietanen 2009, pp. 39–50). Though several semi-industrial scale pilots have been built, it has not yet been carried out anywhere in the world on a production scale (e.g. Örnköldsvik pilot plant was recently abandoned by the developing company SEKAB, SEKAB 2012).

The main technical challenges in the EtOH conversion of wood relate to pretreatment and hydrolysis into short sugars. See e.g. Øyaas (2010) and Lindstedt (2010). On the other hand, the downstream process from short sugars to concentrated EtOH is well-known and proven. Figure 3.4 illustrates the principal process steps in the EtOH conversion of wood (Östman et al. 2005).

²¹ Fatty acid methyl ester. Chemical product made of vegetable oils by esterification. A regular diesel engine can accept a blend of about 5% FAME and 95% fossil diesel (Juva 2008).

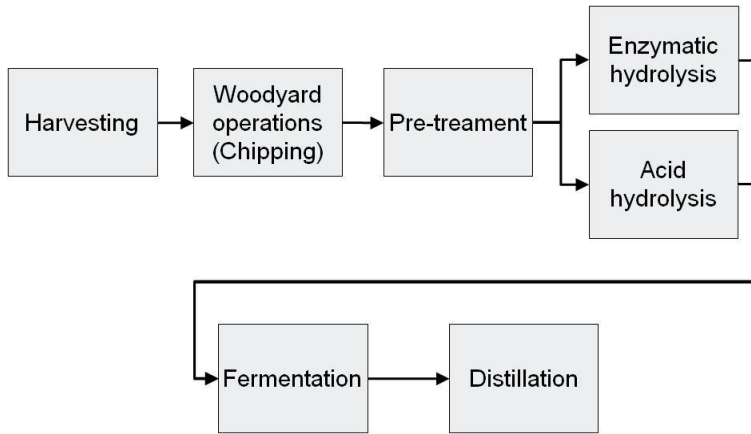

Figure 3.4. Principal process steps in converting wood biomass into EtOH.

RCP, on the other hand, is easy to convert into its cellulosic form, and is available in large quantities at prices well below any virgin pulps. See figure 3.5 (Östman et al. 2005).



Figure 3.5. Principal process steps in converting RCP into EtOH.

It is obvious that if RCP is confirmed to be an advantageous feed stock for EtOH manufacturing, and if biofuels-related political targets are determinedly followed and the corresponding economic incentives set up, the supply of RCP for papermaking might tighten significantly. At present, the cost of RCP and the cost of the energy needed to process RCP into EtOH have not been justified by the price of the product. Also the investments needed are quite significant, easily more than EUR 20 million for the commercial-scale fermentation and distillation only. In addition, the hydrolysis technologies capable of hydrolysing lignocelluloses into short sugars at an industrial scale and at affordable cost have not yet been commercialised (interview of Sipilä E. 2011).

The following example presents a novel and potentially highly competitive concept for producing cellulose-based ethanol.

Urban Ethanol concept

The process developed by the Metso research team for utilising various solid waste streams as a **dual source** of fibre and fuel has already been described in

3. Pre-identification of market trends – need and criteria for the model

section 3.3.1. As opportunities for utilising MSW-based RCF turned out to be quite limited in paper products, the Metso research team interacted with experts in the ethanol conversion of biomass. In a preliminary assessment, the discarded paper found in mixed waste streams, MSW and the like, was found to be the most affordable raw material for biomass-based ethanol (Östman et al. 2005, Sipilä 2010a, pp. 73–74). This is mainly because of the feedstocks' typically negative price (gate fee) and the large by-product value of the non-fibrous fuel fraction. The EtOH conversion of cellulose requires substantial amounts of energy, and, in the Urban Ethanol concept, fuel for generating that energy comes “for free”, as a by-product of these feedstocks. Technically, too, the fibre from MSW (CIW) has been reported as suitable based on early tests carried out in Finland by a consortium of VTT, Pöyry, L&T, Skandinavisk Kemiinformation and UPM-Kymmene (Ranta 2010, Sipilä 2010b). Figure 3.6 presents a mass balance of a stand-alone Urban Ethanol concept. To date this concept has been trialled on a pilot scale, meaning some tons of processed materials, and EU funding has been granted to build an industrial pilot unit with 20,000 m³/a ethanol production capacity (European Commission, Cordis 2010).

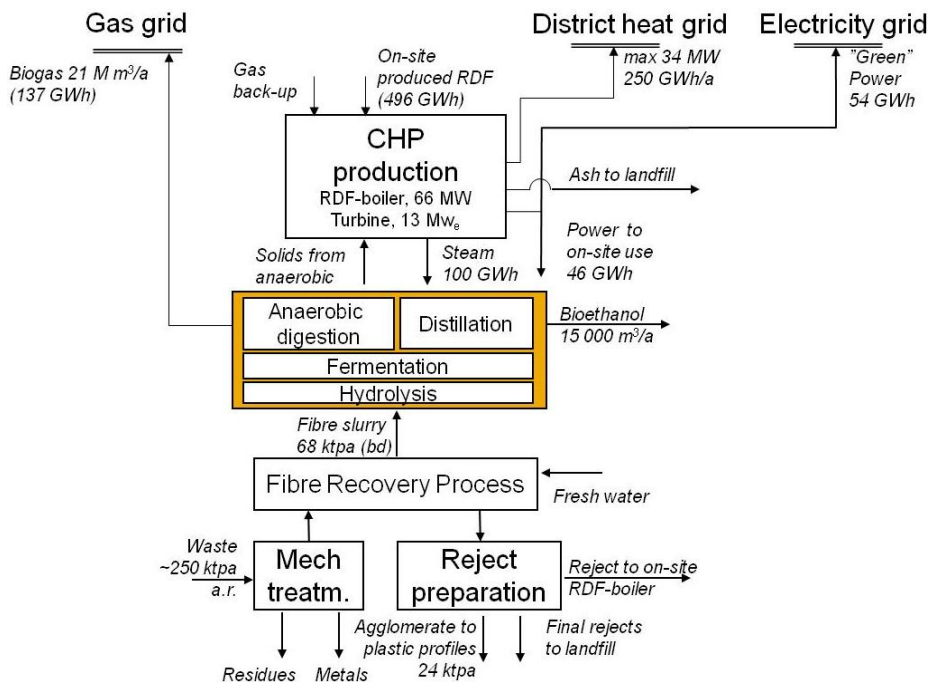

Figure 3.6. Mass balance of stand-alone Urban Ethanol concept.

While the Urban Ethanol concept is an interesting and quite elegant solution for biomass-based transportation fuels, it also produces significant amounts of sur-

3. Pre-identification of market trends – need and criteria for the model

plus heat and electricity²². As district heating is relatively seldom found outside the Nordic countries, the excess heat could be supplied to industrial players that are major users of process steam. This brings us back to the integration of W-t-E with paper mills and the trend for W-t-E-permitted boilers to be built at RCF-utilising paper mills. Figure 3.7 illustrates a concept in which Urban Ethanol is fitted next to a modern case materials manufacturing paper mill and which would be especially lucrative if the W-t-E boiler was also installed by the paper mill.

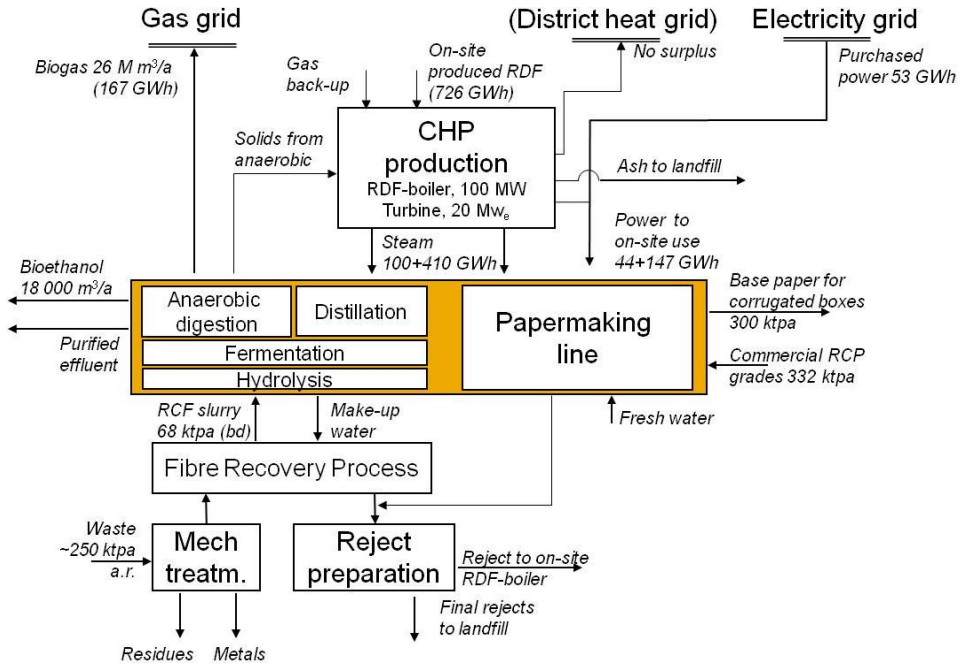

Figure 3.7. Urban Ethanol concept integrated with a large-scale RCF-based paper mill.

This concept is well-balanced in terms of energy: the paper mill consumes all the heat surplus at the power plant and provides the ethanol process with some additional rejects, as well as organic content, in its waste waters. In many cases, the anaerobic digestion can be found already in operation at this type of paper mill. The power generated on-site actually falls a little bit short, and, with the example mass balance depicted in Figure 3.7, an average of some 5 MW must be purchased from the grid.

²² With the assumption that the composition of the feedstock corresponds with the typical CIW or MSW type of streams.

The future production of EtOH from the discarded paper content of miscellaneous waste streams, or even poor-quality RCP, could be considered a ***weak signal*** candidate, similar to the already elaborated Urban Mill concept.

The related renewable-energy-driven development in the fuel use of biomass, and especially wood, could perhaps be considered a ***trend*** with the predictable consequences of:

- increasing demand for wood in fuel use
- increasing price of fuel wood
- some disturbance in the supply of pulp wood.

3.4 Financial analysis of waste-to-energy in a paper mill environment

The applications of waste-to-energy in a paper mill environment definitely sound interesting, but what is the magnitude of their financial impacts on paper mill operations? Is it significant enough to have a serious impact on the industry and the RCF market? How will their competitiveness change if radical changes in the supply-demand relationships of feedstocks take place? This section provides a simple financial analysis to clarify these issues.

3.4.1 Set-up of the financial analysis

The paper mill framework selected for the analysis is the 100% RCF-based manufacturing of base sheet for corrugated containers, i.e. case materials, recycled fluting and testliner. This sector of the P&P industry is the most important user of RCP and the largest sector in tonnage terms, and is growing at an above-average rate globally (Pöyry Forest Industry Consulting 2008).

The analysis does not consider a split of responsibilities between the different actors that are likely to be involved in realising the concepts. In other words, the concepts are analysed for their systemic impact, and the eventual split of risks and rewards between different operators (e.g. waste management company, paper mill and CHP power plant operator) is not considered.

A benchmark representing a state-of-the-art, non-integrated solution and four alternative W-t-E applications highlighting the main features of the previously discussed concepts are picked out for comparison:

Benchmark (BM, Figure 3.8). The benchmark depicts a modern testliner or recycled fluting paper mill with no on-site power production or rejects-processing. The production capacity of the facility is 300,000 tpa, i.e. similar to the majority of new paper machines built for this grade during the last 15–20 years.

3. Pre-identification of market trends – need and criteria for the model

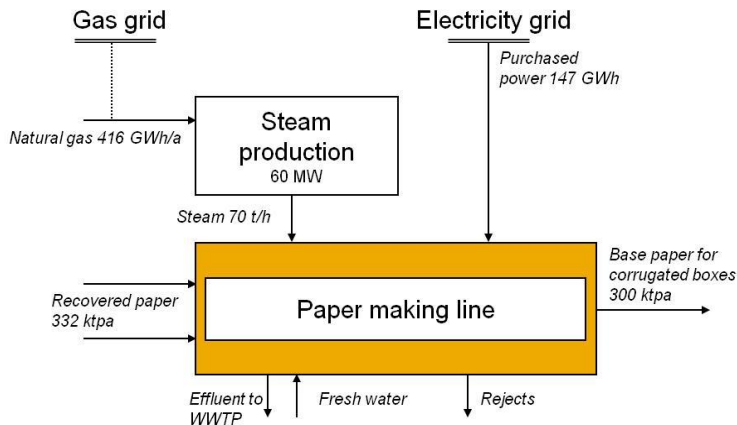

Figure 3.8. Benchmark – a modern non-integrated case-materials-producing paper mill.

Urban Mill alternative 1 (UM1, Figure 3.9). This concept introduces a W-t-E CHP power plant investment adjacent to an existing paper mill, the paper mill being exactly similar to the Benchmark. This example corresponds with the investment activity implemented by the European RCF-based paper industry in the late 2000s as outlined in more detail in section 3.2.

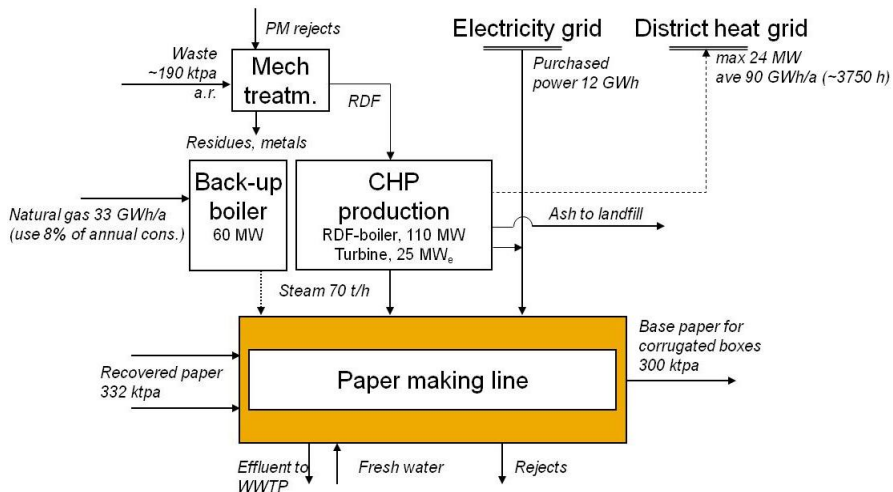

Figure 3.9. “Urban Mill alternative 1” – Benchmark fitted with a modern W-t-E power plant.

3. Pre-identification of market trends – need and criteria for the model

Urban Mill alternative 2 (UM2, Figure 3.10). This concept complements UM1 by fibre recovery from the incoming CIW / MSW as described in section 3.3.1. No direct examples of this concept are yet in industrial operation.

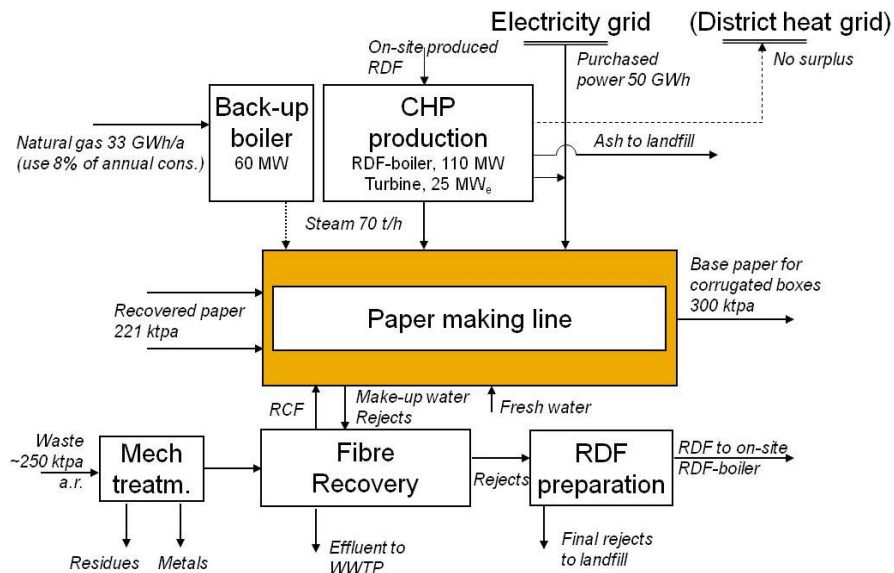

Figure 3.10. “Urban Mill alternative 2” – Benchmark integrated with a modern W-t-E power plant and boosted with fibre recovery from incoming waste streams.

Urban Ethanol alternative 1 (UE1, Figure 3.11). This concept introduces stand-alone ethanol production from MSW, as explained in section 3.3.2. No examples of this concept are yet in industrial operation.

3. Pre-identification of market trends – need and criteria for the model

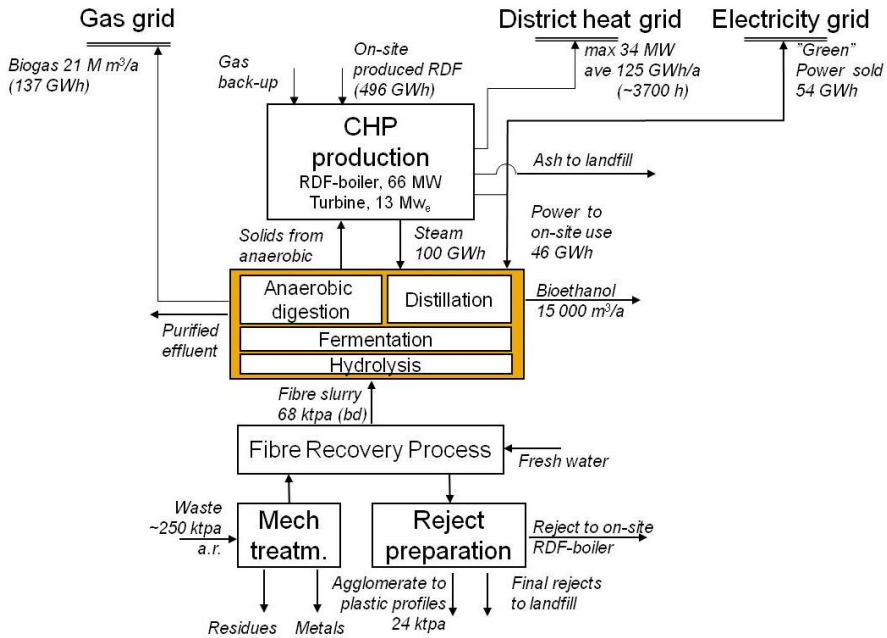

Figure 3.11. “Urban Ethanol alternative 1” – stand-alone ethanol production utilising RCF content in the mixed waste streams.

Urban Ethanol alternative 2 (UE2, Figure 3.12). This concept marries UE1 with the Benchmark, i.e. it places MSW-based ethanol production adjacent to a modern existing paper mill as outlined in more detail in section 3.3.2. The difference between UE1 and UE2 is formed by the integration benefits between RCF-based papermaking and EtOH conversion.

3. Pre-identification of market trends – need and criteria for the model

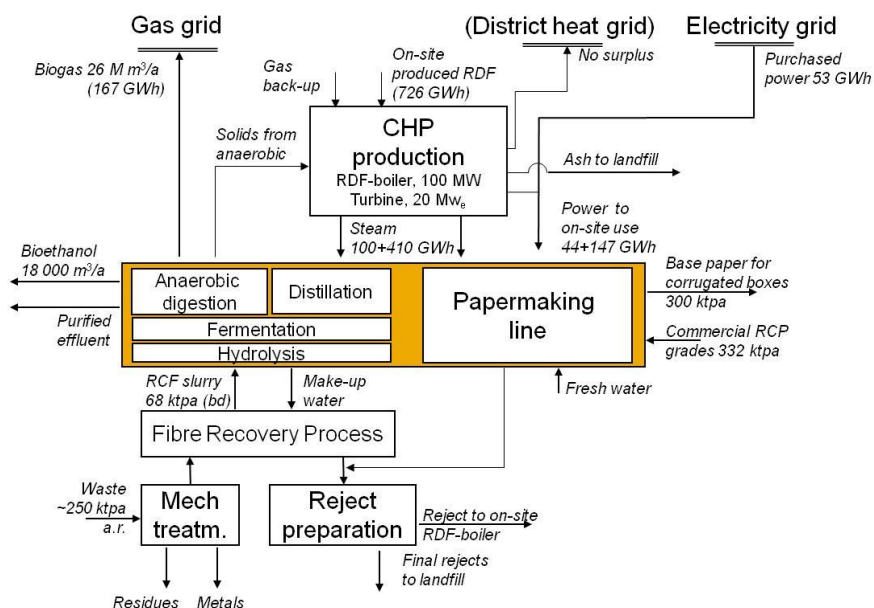

Figure 3.12. “Urban Ethanol alternative 2” – ethanol production integrated with a large-scale RCP-based paper mill.

The financial model used here is fairly simple as it makes no sense to try to form a too detailed picture of the technical concepts, some of which do not yet operate on an industrial scale. If no clear conclusions can be made from a fairly simple model, the practical implications of the concept are likely to be vague. In such a case, the concept is likely to have little relevance to the development of the P&P industry and the RCF market.

The selected concepts have the most relevance in a European setting. The local costs and characteristics of the waste-to-energy business (and the waste business in general) create a window of opportunity for this type of development. This window has emerged as land filling of MSW and CIW has been made uncompetitive or even inapplicable by regulatory actions²³. Therefore the concepts are analysed in a typical European setting and at corresponding unit price levels. Such variables include the cost of utilities, the price of products sold, etc. Table 3.2 summarises the monetary value of the main variables used in the financial modelling.

²³ The landfill directive (1999/31/EC) prohibits the landfilling of untreated waste and sets strict demands for the technical realisation of the landfills. The national adaptations of this directive within the EU vary to some extent, but have generally led to untreated waste being gradually banned from landfills.

Table 3.2. Main variables used in the financial analysis.

Unit prices	Sold	Purchased
District heat	28 €/MWh	n/a
Electricity	45 €/MWh	54 €/MWh
Gatefee for waste	80 €/t (a.r.)	n/a
Rejects disposal	n/a	80 €/t (a.r.)
Biogas (sold), natural gas	40 €/MWh	30 €/MWh
EtOH	0,80 €/l	n/a
Recovered metals	120 €/t	n/a
Ash disposal	n/a	80 €/t
PO plastics agglomerate	200 €/t	n/a

Table 3.3 summarises the results of the financial modelling using the unit price levels given above. The operating cost structure of case materials manufacturing corresponds with a typical European setting (source: company data).

The information in Table 3.3 details the annual revenue of the concepts by its source, including not only the paper itself, but also the waste treatment (i.e. gate fees for incoming waste), the revenue from the various energy products and from recyclables separated from the feedstocks. As a summary, all revenues and costs are also presented proportional to the annual paper production, i.e. as €/t of net paper output. It means that 99.8% of the revenue of the benchmark consists of the sold paper, whereas in UE2 the corresponding figure is 72%. UE1 includes no paper production at all, thereby making the “€/t” column inapplicable.

Below the revenue split, Table 3.3 presents the cost of raw materials for papermaking, i.e. the fibre, starch and other additives. Again, this factor does not apply for UE1. Next, the table presents the variable costs of the operations, now including not only paper making, but also the costs of other operations under the particular concept; e.g. W-t-E power plant, waste treatment, ethanol production, etc. The same applies to the personnel and other fixed costs.

The financial modelling of the *benchmark* stops at the level of EBITDA; i.e. the model takes no stand on eventual depreciation, working capital, financing costs, taxes and similar likely to affect the benchmark. The other four concepts are then analysed for their ability to *improve* the performance of the benchmark. In other words, what is each concept’s contribution to EBITDA and respectively what is the required investment to achieve that contribution? The depreciation period used is 15 years and the depreciation allowances are equal.

3. Pre-identification of market trends – need and criteria for the model

Table 3.3. Financial summary of the concepts.

Paper mill capacity, t/a	Benchmark (BM) 300 000		Urban Mill alt. 1 (UM1) 300 000		Urban Mill alt. 2 (UM2) 300 000		Urban Ethanol alt. 1 (UE1) 0		Urban Ethanol alt. 2 (UE2) 300 000	
	'000 Eur/a	Eur/t	'000 Eur/a	Eur/t	'000 Eur/a	Eur/t	'000 Eur/a	Eur/t	'000 Eur/a	Eur/t
Gros sales	108 204	360,7	126 366	421,2	131 210	437,4	48 894	n/a	149 444	498,1
- Paper	108 000	360,0	108 000	360,0	108 000	360,0	0	n/a	108 000	360,0
- Waste treatment			15 200	50,7	20 000	66,7	20 000	n/a	20 000	66,7
- Power							2 430	n/a		
- Heat			2 506	8,4	2 478	8,3	3 584	n/a		
- EtOH							12 000	n/a	14 080	46,9
- Biogas							5 480	n/a	6 560	21,9
- Recyclables	204	0,7	660	2,2	732	2,4	5 400	n/a	804	2,7
Distribution	-7 500	-25,0	-7 500	-25,0	-7 500	-25,0	0	n/a	-7 500	-25,0
Sales, ex mill	100 704	335,7	118 866	396,2	123 710	412,4	48 894	n/a	141 944	473,1
Raw materials	-35 300	-117,7	-35 300	-117,7	-24 653	-82,2	0	n/a	-35 300	-117,7
Value added	65 404	218,0	83 566	278,6	99 057	330,2	48 894	n/a	106 644	355,5
Gas/steam	-12 480	-41,6	-990	-3,3	-990	-3,3	-150	n/a	-990	-3,3
Electricity	-7 938	-26,5	-648	-2,2	-2 700	-9,0	-162	n/a	-2 862	-9,5
Maintenance	-6 000	-20,0	-7 500	-25,0	-8 500	-28,3	-3 000	n/a	-9 000	-30,0
Reject disposal	-2 720	-9,1	-552	-1,8	-576	-1,9	-1 840	n/a	-2 104	-7,0
Other variable cost	-4 000	-13,3	-4 500	-15,0	-4 500	-15,0	-2 000	n/a	-5 000	-16,7
Total variable cost	-33 138	-110,5	-14 190	-47,3	-17 266	-57,6	-7 302	n/a	-19 956	-66,5
Contribution	32 266	107,6	69 376	231,3	81 791	272,6	41 592	n/a	86 688	289,0
Wages & salaries	-9 600	-32,0	-11 600	-38,7	-11 600	-38,7	-4 000	n/a	-13 600	-45,3
Other overhead	-3 600	-12,0	-4 600	-15,3	-4 600	-15,3	-3 000	n/a	-6 600	-22,0
Total fixed	-13 200	-44,0	-16 200	-54,0	-16 200	-54,0	-7 000	n/a	-20 200	-67,3
EBITDA	19 066	63,6	53 176	177,3	65 591	218,6	34 592	n/a	66 488	221,6
EBITDA %	18 %		42 %		50 %		71 %		44 %	
EBITDA improvement			34 110	113,7	46 525	155,1			47 422	158,1
Required investment, M€			110		127		129		139	
Depreciation			-7 333	-24,4	-8 467	-28,2	-8 600	n/a	-9 267	-30,9
EBIT							25 992	n/a		
EBIT%							53 %			
EBIT improvement			26 777	89,3	38 058	126,9			38 155	127,2
ROCE%			24 %		30 %		20 %		27 %	

3.4.2 Key results of the financial analysis

Urban Mill alternative 1

An investment in a large-scale, waste-to-energy power plant, dimensioned against the power and steam consumption of the paper mill, is a substantial strategic investment, i.e. of the same order of magnitude as the annual net sales of paper production and roughly the same size as all the papermaking equipment. However, the concept introduces significant new revenue in the form of waste treatment and heat sales (+17%) and simultaneously cuts the total variable and fixed costs per

ton by a third (!) – even when the opex of the waste treatment and the power plant are included in the figure. This improvement is a result of the substantial energy self-sufficiency, combined with the utilisation of on-site rejects as a fuel.

Despite the high investment cost, the ROCE% measured as EBIT improvement against the required investment is at a fairly good level of 24%. In view of this modelling it is easy to understand why European producers have lately eagerly grabbed this opportunity.

It is, of course, debatable whether the paper mill can claim the assumed heat sales. Typically there are not that many suitable district heating grids in operation, but some industrial or commercial facilities may be available nearby that could potentially use some of the available heat. The calculation summarised in Table 3.3. assumes 4000 annual hours of heat sales. Even if this figure is reduced to zero, the ROCE% still remains at 22%, showing the limited impact of heat sales.

In a Western European context, the assumed volume of waste treatment (190 ktpa CIW/MSW (a.r.)) represents an inhabitant base of fewer than 1 million people, whereas the consumer base corresponding to a paper mill output of 300 ktpa case materials is around 5–6 million people (Pöyry Forest Industry Consulting 2008). Recent development in the industry has shown that there are also opportunities to invest in additional (and very effective) W-t-E capacity in Germany – a country that already has reasonably well-developed waste management structures and quite substantial waste incineration capacity (Sipilä et al. 2009). While it must be recognised that this development has been partly stimulated by the German Renewable Energy Resources Act of 2000 (Sipilä et al. 2009, pp. 21–22), it is difficult to understand why similar development would not take place in other European countries where waste management infrastructure is less developed and the opportunities for investments in technically and commercially effective concepts are even better.

Urban Mill alternative 2

The UM2 concept provides an interesting comparison with the already proven UM1. In addition to the benefits of UM1, it adds the element of fibre recovery to papermaking from selected paper-containing flows. Under this concept the papermaker is, in theory, able to tap the RCF content in the CIW (even MSW) that otherwise would be combusted. The fuel flow for combustion still remains at a level that gives the paper mill self-sufficiency in process heat, even though the integrate is a net purchaser of electricity (for approximately 20% of its needs – the volume of waste input has also been increased by some 30% in comparison to UM1).

The fibre recovery process and the increased volume of feedstock for waste processing increase the investment by EUR 17 million (15%) and revenues by 4% but simultaneously reduce the raw material cost of papermaking by some 30%. This results in a ROCE of 30%, again measured as the EBIT improvement against the benchmark.

As discussed in section 3.3.1, the fibre content in these mixed flows must not nowadays be in contact with foodstuffs, unless the waste stream can be classified as a source-separated flow. It is unlikely that there are ready volumes currently available for realisation of the UM2 concept on a large scale in the production of case materials. While the UM1 concept provides the opportunity for large-scale on-site rejects utilisation, operations under the UM2 concept are likely to emerge in smaller steps – first by investing in the capacity to effectively treat high foreign content RCP and by introducing, say, 10% of the raw material flow from composite materials with a high reject content while still partly maintaining the benefits indicated in Table 3.3. Typically, the gate fee that the waste processor can command for such flows is lower than for the more mixed CIW/MSW, thereby reducing the revenues from waste treatment.

Urban Ethanol alternative 1

UE1 is an innovative concept for stand-alone ethanol production from MSW or CIW. Its competitiveness is very much dependent on the local price conditions (tax incentives) for its outputs, mainly biomass-based ethanol and biogas. The calculation summarised in Table 3.3 assumes 80€/l for the EtOH and 40€/MWh for the biogas fed into the gas grid. Under these conditions the ROCE of the investment becomes a reasonable 20%, calculated without any investment subsidies and a 15-year depreciation time. Naturally, in the absence of industrial-scale references, the operating costs for the EtOH conversion out of RCF content found in MSW are at present highly speculative.

An interesting feature of the UE1 concept is that its revenue is compiled from six main components. The profitability of the concept is thus really sensitive, for only one of these components (fees from waste treatment, 41% of the revenue). It can withstand fluctuations in the unit prices of outputs very well – assuming prices do not all dip simultaneously. In the concept's set-up depicted in Figure 3.11, one of the outputs is district heat, and the calculation summarised by Table 3.3 assumes 4000 hrs/a of heat sales at maximum capacity. Without an opportunity for heat sales to a third party (as is often the case) the ROCE drops by 3%-units.

The market price of tropical EtOH is today around 60–70 €/l (about 1 €/l gasoline equivalent), i.e. higher than the untaxed refinery price of gasoline which is around 50 €/l (interview of Sipilä K. 2011). At an unsubsidised market price level of 50 €/l gasoline equivalent (i.e. without any tax benefits) the ROCE of the UE1 concept falls to around 15% and further to around 10% if the biogas cannot be sold to the grid or a third party. In the absence of the gas grid, there is an opportunity to somewhat increase the EtOH yield, but this unfortunately increases the opex in a fashion that would rather call for other on-site uses of the biogas, such as bio-electricity production (interview of Sipilä E. 2010). On the other hand, investments in biomass-based ethanol are very likely to receive incentives from budget funds or price guarantees for its outputs (i.e. feeding tariff) thus significantly improving the project owners' payback and reducing the vulnerability to market fluctuation. It is worth noting that the sole conversion of separately-collected RCP

into EtOH is not supported by the analysis. The combustible reject flow from regular RCP is not enough for the energy needs of EtOH conversion, and nor does the relatively high price of RCP (in comparison to MSW!) support this scenario. In fact, MSW provides combustible reject in quite good quantities in relation to cellulose fibres. Theoretically, the ratio of fibre to combustible non-fibrous component would be at its optimum at around 2:1, whereas the ratios found in practice are less than 1:1 (Ristola 2004b, Hietanen 2009).

Urban Ethanol alternative 2

The UE2 concept marries UE1 with the Benchmark; i.e. it places MSW-based ethanol production next to a modern, existing paper mill. Table 3.3 reports some potential benefits in comparison to the UM1 concept, while the investment is 26% larger than the already very substantial investment in a dedicated W-t-E power plant (UM1). Potential gains from the higher value-added W-t-E operations include conversion of fibre-containing rejects from the paper mill into EtOH, as well as benefits in joint anaerobic waste water treatment. Thus UE2 will top UM1 in profitability given the market conditions listed in Table 3.2.

In comparison to the stand-alone EtOH production represented by UE1, integrated operation with a paper mill provides a “24/7” sink to all excess process heat available from the EtOH conversion. As usual with W-t-E, this clearly improves the profitability of operations. In practice, there are no such market conditions in which UE1 would top UE2 in profitability.

Sensitivity of the results to the main assumptions

So far, we have discussed the competitiveness of different Waste-to-Energy investments at paper mill sites in market conditions that roughly represent today's situation in Western Europe. A quick sensitivity analysis reveals that none of the concepts works very well in landfill-driven waste management systems. In Figure 3.13 we assume in cumulative steps that 1) the price level of waste and reject disposal was significantly lower, 2) district heat sales were not available, 3) biogas sales were not available, and 4) there was no price premium for the produced ethanol.

The analysis reveals that the presented concepts are competitive mainly in an environment where legislation and taxation have created a high-enough price level for waste treatment (including RCF rejects), and where bioenergy (and W-t-E) is politically supported.

3. Pre-identification of market trends – need and criteria for the model

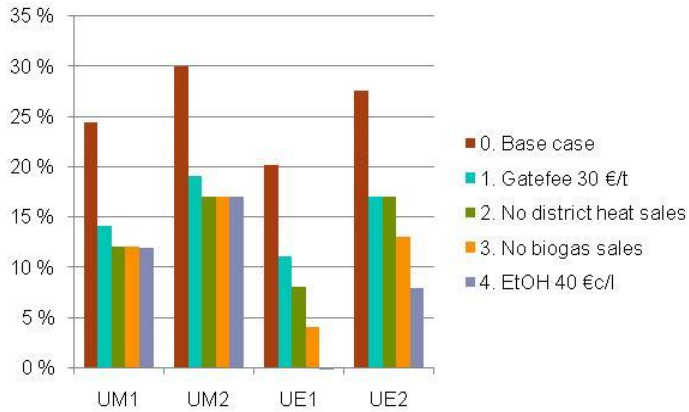

Figure 3.13. Sensitivity of the modelled ROCE-% to key assumptions, part 1.

Another important question is how the competitiveness of the presented concepts would change, if market development resulted in significant changes in RDF (or SRF) supply-demand relationships – i.e. if the tipping fee of waste was clearly reduced as a result of abundant high-efficiency W-t-E capacity on the market, and if the cost of RCF reject disposal was reduced to zero as a consequence of the same. There is already, at least regionally, some evidence of such a development (interview of Hietanen L. 2011). An interesting factor is naturally also the EtOH yield that is likely to decrease as RCP collection is gradually perfected. On the other hand, profitability might increase, if the EtOH yield of the feedstock was increased by blending in lots of poor-quality RCP, even at relatively high prices. Figure 3.14 presents a summary of the sensitivity analysis by taking these four steps in cumulative fashion.

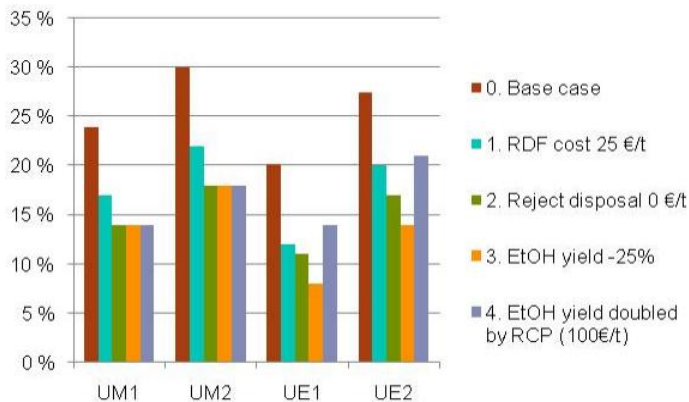

Figure 3.14. Sensitivity of the modelled ROCE-% to key assumptions, part 2.

These results that have been calculated without considering any investment subsidies (typically available for new biofuels technology) indicate that the proposed concepts are financially interesting, especially in the legislative and political conditions that prevail in Western Europe. Consequently, large investments that rely on processing the RDF-type of feedstocks that still have some discarded paper content and that can also effectively utilise poor-quality RCP for fuel conversion, might potentially cause turbulence in the present RCP market. In the spirit of *constructive research* this result underlines the need for a composite S/D model that can accurately handle the combined effect of developments on the fibre market and on the waste fuel market.

3.5 Other pre-identified trends

There are a couple of other trends identifiable on the market that can be considered to support the assumption that advanced W-t-E operations will become increasingly common at paper mill sites in the future.

3.5.1 Trends in RCP collection

There has been significant improvement in RCP supply, i.e. in the collection of waste paper, in Europe and the US during the 1990s and 2000s. The collection rates have risen steadily and have recently reached 55% in the US and 60% in Europe (see Appendix I). The latest European figures report collection rates of above 70% (European Recovered Paper Council, 2010). This has been achieved largely by intensified household collection. Collection rates from big producers in industry and commerce have always been much higher than from households and are today almost complete in the case of OCC. There is room for improvement mainly in household collection (Stawicki and Read 2010, p. 41–49).

Household collection first concentrated on ONP/OMG grades, but when growth in volumes became exhausted, it was gradually extended to packaging grades as well. Different countries, regions and cities have adopted different methods, but basically all are striving to increase the collection from households (Stawicki and Read 2010, p. 41–49). It has also been shown that there is significant fibre potential in the remaining household fraction. It contains plenty of good quality fibre that is being rotated for the first time, e.g. in various food packaging (Anon 2003, Company files).

A clear trend in household collection, especially in the US and the UK, has been the adoption of a so-called single stream system, where all recyclables, whether paper, paperboard, cardboard, glass, tin, plastic containers, PET, etc. are collected commingled in either one or two containers. The materials are then *negatively sorted* at so-called material recovery facilities (MRFs) semi-automatically. Various ballistic or gravi-metric sorting methods, sometimes also near-infra-red, are utilised and the required RCP quality is finally achieved by hand-picking foreign material from the separated paper streams (Ristola 2004b).

The sorting at MRFs is quite labour-intensive, but, considering the advantages in collection and the commingled system, creates significant net savings of up to 35 £/t (Davies 2002). And, what is politically most important, the recovered volumes are increasing sharply. However, recent UK research by WRAP (2008) found no benefits in yield or net costs resulting from single stream collection and the MRF sorting systems. In fact, traditional separation at source showed the best yields and the lowest costs. The market evidence, i.e. the fast-growing use of single stream systems, speaks for the opposite interpretation. E.g. in the US in 2009 there were 578 MRFs sorting mainly discarded-paper-containing flows, some 5% of which treated totally unsorted MSW (US EPA 2010). The American Forest and Paper Association (AF&PA 2007) estimated that 50 per cent of US kerbside recyclables collection programs were single stream in 2007²⁴. These programs require that the materials are taken to a materials recovery facility (MRF) for processing.

The paper industry has strongly opposed single stream collection, perhaps short-sightedly (e.g. Moore 2003, Ristola 2004b). The industry fears increasing amounts of foreign material in waste paper, and especially the shards of glass that have been seen to increase in RCP. According to US industry research, a true single stream system yields 10% reject at MRFs, which is double that of a dual-bin system where all paper material from households is combined in one container (similar to the German system). The cost impact at paper mills has been estimated at 10 \$/t (Moore 2003).

In a situation where Asian demand for RCP is soaring, its supply from other than households is fully utilised and any improvement is dependent on household collection, the conclusion is clear: the only way for the industry to combat rising RCP prices is to significantly increase household collection. This can only be achieved with collection systems that make recycling dramatically easier for citizens. That is the very essence of commingled collection.

If the spread of commingled collection is accepted as a *trend*, there is consequently a need to develop paper mills' capacity to tolerate a higher degree of various kinds of impurities in recovered paper. In fact, this should be evident already, looking in the rear-view mirror. E.g. the amount of stickies in European DIP grade waste paper almost doubled between 1999 and 2003 (Spiess and Renner 2004). A striking correlation of 0.94 has been reported between the amount of foreign material and the share of negatively sorted mixed waste paper in paper mills' raw material mix (Bülow 2005).

If foreign material and stickies in RCP are bound to significantly increase, it will result in greater percentages of pulping and screening rejects, playing in favour of on-site reject utilisation, a prime example of which is direct combustion in the W-t-E boiler, i.e. the UM1 concept.

²⁴ Kerbside collection of recyclable waste (e.g. recovered paper) means collection of household wastes by dedicated containers at the roadside or inside special waste collection sheds.

3.5.2 Increasing importance of RCF rejects disposal

Quite apart from the tendency for reject amounts from RCF processing to increase, there is also another reason that supports investment in their treatment and utilisation – the associated cost. The cost of reject disposal relates not only to on-site preparation of the material for consequent off-site treatments, but also, and more importantly, to the gate fees commanded by waste management operators for these different off-site treatments. The disposal cost for various screening rejects and wet sludges has typically been around 80 €/t (a.r.). In his 2005 article, Bülow calculated that the reject amounts and typical disposal costs in Germany in relation to one ton of ready RCF furnish in a paper machine headbox will be in the range of 20–30 €/t, depending on the cost level and the percentage of foreign material (Bülow 2005). This represents a significant cost in comparison to the typical RCP prices of around 100 €/t, and many paper mills have taken actions to mitigate the rising costs of reject disposal.

There are also recent developments in regional legislation, especially within the EU, that have put clearly more pressure on finding more innovative methods for rejects treatment and utilisation. Recent EU legislation has had at least the following impacts on RCF reject disposal practices:

- The EU landfill directive (1999/31/EC) will eventually ban the dumping of *biodegradable* wastes, including RCF rejects, in landfills. The minimum solution in order to comply is to incinerate the reject and dispose of the ash.
- The waste incineration directive (2000/76/EC) requires the paper mill power plants co-combusting their RCF rejects to be permitted for waste incineration and to comply with emission levels that are similar to those for dedicated waste incineration facilities. This increases the cost of flue gas treatment and might slow down investments in the sensible co-combustion of rejects together with fossil fuels and biofuels, e.g. hog fuel.

For instance, in Germany, the 2005 ban on dumping untreated material in landfills due to the EU landfill directive (1999/31/EC) has further increased the disposal cost of rejects (Bülow 2005).

Considering the trends in reject quantities and the cost pressures in RCF reject disposal that have resulted from on-going regulatory changes, it is no wonder that several researchers, entrepreneurs and multinational corporations have become active in this area (see e.g. van Kessel 2005). In fact, the goal of development work has recently changed from “reducing the cost” into “how to maximise the value” of these wastes (see e.g. Westenbroek 2009). These activities relate not only to on-site combustion, but also to the recovery of valuable minerals, the mechanical and chemical recycling of plastics, and the more careful washing of recycled fibres. Not surprisingly many of the researched concepts benefit from an on-site W-t-E boiler.

The increasing cost of RCF reject disposal can be considered a *trend* with the predictable consequences of:

- increasing investments in on-site W-t-E capacity
- increasing R&D investments in converting RCF residues into valuable products.

3.6 Summary and discussion of relevant trends concerning the RCF market

The examples, or narratives, discussed in this chapter demonstrate three important lines of thought related to the supply and demand of recycled fibre. Firstly, it is argued that ***the cost competitiveness of RCF, on both a capex and opex basis, is so strong*** that it by-passed economies of scale in linerboard and enabled mini-mills to mushroom in the US in the 1990s. There is no reason to believe that the market share of recycled fibre among papermaking raw materials will not continue to rise, as long as the supply of RCP can keep up with the demand. Ultimately, the development of RCP collection schemes will not be able to keep up with the pace of increasing demand. Thus we will, at least from time to time, witness periods of tight supply which will, in turn and at certain price levels, discourage further investment in RCF-based production capacity.

The second lesson is the on-going breakthrough of ***on-site waste-to-energy at RCF-based paper mills***. The development we have seen in the past five years might be just the beginning, and it is questionable whether waste-to-energy plants will any longer be built on condensing power alone. Industrial CHP is far more efficient and, as there are other synergistic benefits related to the residues of papermaking, the industrial symbiosis with papermaking appears to be stronger than that with any other industry (interview of Glorius 2010). The impact of this development on the supply-demand balance of RCF is that the existence of waste sinks or utilisation on-site at paper mills will decrease reject handling costs and steam costs, thereby further increasing the competitiveness of RCF and increasing demand for it to higher levels. In addition, the growing combustion of wastes that still include some discarded paper will reduce the potential for further expansion in RCP collection.

The third and somewhat indirect, yet potentially biggest, impact on the supply-demand balance of RCF comes with the concept of waste as a ***dual source of fibre and fuel***. Gradually enabled by recent investments in on-site waste-to-energy at RCF-based paper mills, this concept has the potential to ease the supply of RCP. While it can provide some new streams for fibre utilisation in an economical manner, in theory it also has the potential to decrease the cost of RCP collection. This applies especially to OCC. So far, packaging waste from commerce has been the most significant source of separately collected OCC. The people who fill the shelves in supermarkets have spent a lot of time and effort in separating all plastics and composites from corrugated board. Collection by separate vehicles and potentially by separate operators also increases the cost. Furthermore, there is often additional separation or sorting by waste operators at transfer stations (interview of Hietanen L. 2009). The concept discussed here

offers an opportunity to deliver the source-controlled packaging waste of commerce for utilisation as combined fibre and fuel at suitably equipped paper mills. Similarly, this concept opens up new opportunities to make the collection of post-consumer packaging more efficient.

The current political trend to reduce developed economies' dependence on fossil fuels will also indirectly hit the market for RCF used in papermaking. In the long term the **increasing price of wood** will also increase the price papermakers are ready to pay for RCP. There will be no overnight impact, but new investment decisions come gradually, and the alternative of using RCP as a raw material will increasingly outplay the other raw material strategies.

This trend would be further amplified **if RCF became a major raw material for EtOH conversion**. Even if RCF for EtOH conversion was actually extracted from more mixed waste flows than regular RCP, it would indirectly tighten the supply of RCF for papermaking. As RCF gains market share among papermaking raw materials, the collection of RCP will naturally need to respond to the increasing demand. If the potential to increase RCP collection is partly offset by directing feedstocks for EtOH conversion, this will have a major adverse effect on the supply side. The effect is likely to be significant because the costs of collection will be much lower for more mixed streams than for normal source-separated RCP. Why should one invest in burdensome source-separation-based collection, if better margins are available simply by feeding the EtOH processes?

Reject disposal already represents 5% of turnover for many of the 100% RCF-based paper mills (Wunsche and Niemczyk, 2004). In EU legislation the main impacts on RCF reject disposal come from the landfill directive (1999/31/EC), from the waste incineration directive (2000/76/EC), and – even if indirectly – from climate policy in general. The on-going trend of investing in on-site W-t-E at RCF-utilising paper mills is capable of providing a simple solution to utilise the combustible fraction in the reject. Dedicated reject combustion facilities, as demonstrated by Papierfabrik Palm at their Wörth site, for example, are also likely to emerge (Thalheimer and Haas, 2008). Some purification techniques from the plastics recycling industry may find a use in RCF rejects processing as the amount of foreign material keeps rising in RCP – or when other waste material flows are utilised by the paper mills, as suggested in section 3.3 of this study.

As explained in this study there are significant demand trends for both wood raw material and RCF that indicate that there will be shortages in supply in the coming years. This means that the industry should support new methods for sourcing RCF that are capable of gaining significant new volumes. Otherwise the raw material cost of the industry is doomed to rise, making the end products ultimately less competitive against new substitutes, and competing media and packaging materials. The US and UK experience of **single stream collection** indicates that there is good potential to collect economically significant additional volumes of RCP. The drawbacks of commingled collection systems include **rising reject volumes**. However, this coincides with a situation where the European paper industry has been forced against the wall and must introduce new, more innovative and less costly methods of reject disposal. In an optimal system, the industry

would be able to turn the minerals and plastics contained in the RCF rejects into valuable by-products, and would also be able to divert the poorest quality fibres for utilisation as energy.

The adoption of more mixed streams of recyclables has been made possible by major investments in on-site W-t-E at RCF-based paper mills, by which the newly refurbished paper mills can effectively take advantage of the combustible foreign material in their raw material flows.

3.7 Observed need for an S/D model of the composite RCF market

Business-as-usual in the RCP market indicates a tightening supply-demand balance. This is a simple conclusion that combines the estimated increase in RCP utilisation with the common understanding of industry experts that collection rates are becoming saturated (e.g. the findings of the European COST E48 research program briefly referred to in section 1.1.1). Using the foresight terminology adopted in Chapter 2 of this report, this should be considered to be the *primary forecast* for RCP market development.

Besides being traded as RCP, discarded paper is found in other waste streams as well. Chapter 3 has drawn attention to a number of trends and weak signals that point to the need to understand the *composite* RCF market, i.e. the interplay between its fibre and fuel use. Table 3.4 presents a summary of the pre-identified trends that are related to applications of W-t-E at paper mills and that have a potential impact on the composite RCF market. The classification used in Table 3.4 must be considered as preliminary and is expected to change in the course of the Delphi study; for example, several trends can be expected to qualify as *strong prospective trends*.

Table 3.4. Pre-identified trends.

Trend	Type	Potential impact on the composite RCF-market
1. Sustained competitive advantage of RCF over virgin fibre	Transient invariance	Continuing growth in utilisation, gradually tightening supply of RCP
2. Implementation of W-t-E at paper mills (direct combustion)	Trend	Further improved competitiveness of RCF-based paper manufacturing, increasing amounts of discarded paper are combusted among wastes
3. Utilisation of fibre content recovered from waste fuels as additional raw material component	Weak signal	Improved supply of RCF
4. Increase in use of biofuels, especially wood	Trend	Increases wood prices and eventually the demand and paying capacity for RCP
5. Utilisation of fibre content recovered from waste fuels in EtOH conversion	Weak signal	Increasing amounts of discarded paper would be converted into EtOH. Possibly poor quality RCP mixed-in.
6. Spreading of commingled collection of RCP	Trend	Improved supply of RCP, increased foreign material and thereby reject content from RCF processing
7. Increasing rejects disposal cost from RCF processing	Trend	Reduces competitiveness of RCF-based paper manufacturing, encourages investments in on-site W-t-E boiler capacity (Trend 2)

Considering this list (even without the weak signals) and the magnitude of the financial impacts of the new concepts (presented under 3.4.), there emerges a need to understand the behaviour of the **composite RCF market**; as fibre raw material and as fuel. Are *secondary or tertiary forecasts* to the assumed *primary forecast* likely to emerge? Can the spreading combustion of refuse-derived fuels containing significant amounts of discarded paper that are currently outside collection hamper the future expansion of RCP collection? Can it even lead to a decrease in the separate collection of RCP?

The only logical answer to Q1 is: Yes, there is an observed need for a model of the composite RCF market that covers its use both as fibre raw material and as fuel.

3.8 Criteria for the new construct

The scientific criteria for the new construct are obviously that it must be able to meet the research objectives in a valid and reliable way. From the perspective of substance or practical relevance, **the model of the composite RCF market** must be able to shed light on the typical questions stemming from an analysis of the pre-identified trends listed in Table 3.4:

- Will the competitive advantage of RCF over virgin fibre be sustained?
- What will the impacts of continued investments in W-t-E at paper mills be?

3. Pre-identification of market trends – need and criteria for the model

- What if the fibre content in waste fuels could be utilised as an additional raw material component? What if that happened on a large scale?
- What will the impacts of an increase in the fuel use of wood be?
- What if the fibre content in waste fuels could be utilised in EtOH conversion? What if that happened on a large scale?
- What will the impacts of spreading commingled collection be?
- What will the impacts of higher reject disposal costs be?

The formal answer to Q2 is: The model of the composite RCF market must be able to deliver practical utility in the form of better understanding of the interplay between the RCP market and the fuel market in a valid and reliable way.

4. Modelling the supply-demand behaviour of recycled fibre

The objective of this chapter is to define answers to the following research questions:

Q3: Are there pre-existing theoretical models that satisfactorily meet the need to understand the composite RCF market?

And if no:

Q4: What does the model of the composite RCF market look like? This chapter first introduces the reader to the central concepts of price theory that are later used for describing the supply-demand behaviour of recycled fibre. This is followed by an overview of today's RCP market, a summary of previous works in the econometric analysis of the RCP market, and finally the author's proposal for a supply-demand model of the composite RCF market.

4.1 Introduction to price theory

As a significant proportion of the target audience for this report are probably not familiar with the basic concepts of price theory, the following very condensed introduction is deemed necessary.

The qualitative supply-demand model drafted later in this chapter is based on the general price theory of economics dating back to the landmark works of Adam Smith, David Ricardo, Alfred Marshall and like, in which the demand for factors of production is also dealt with. In price theory, the demand for factors of production is classified as *derived demand*, as the demand is partly derived from *information external* to the market of the factor itself. (See e.g. Landsburg 2008, Stigler 1987.)

The traditional way of representing supply and demand curves in a *competitive market* is presented in Figure 4.1 (see e.g. Mankiw and Taylor 2006, p. 64). In a competitive market there are many buyers and many sellers, so that each has a negligible impact on the market price. Perhaps a high definition TV panel could serve here as an example of a product with a competitive market which can be thought to qualitatively follow the behaviour described by the supply and demand curves of Figure 4.1.

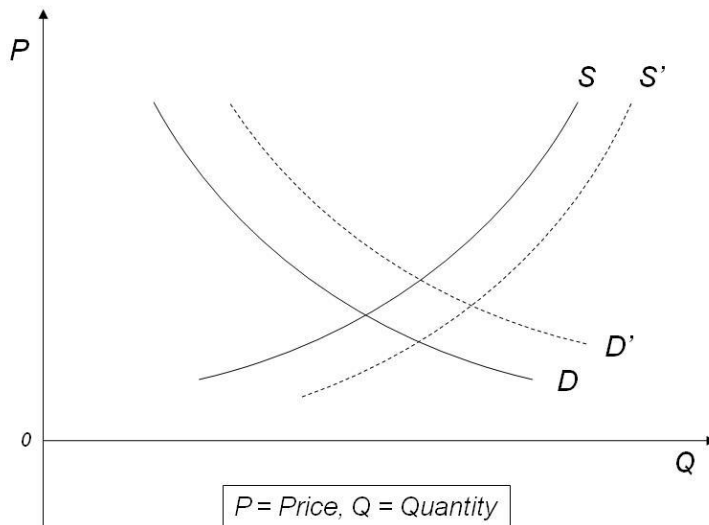

Figure 4.1. Traditional supply and demand curves²⁵.

A competitive market obeys the *law of demand*, i.e. as the unit price decreases, the quantity demanded increases considerably. Similarly, according to the *law of supply*, when the price increases the quantity supplied also increases. On the other hand, in a given set-up of existing production facilities, the marginal cost of supply increases by quantity; i.e. adding weekend work shifts makes the marginal cost of producing additional TV sets higher and higher. In the end the producer decides to invest in a new, more efficient factory or production line, which results in a shift in the supply curve: $S-S'$ (Landsburg 2008, Mankiw and Taylor 2006).

Similarly, shifts in the demand curve $D-D'$ can result from e.g. changes in income, changes in the prices of related goods, changes in taste and changes in expectations (Landsburg 2008, Mankiw and Taylor 2006). Perhaps a topical example of a demand curve shift in the HD TV market could be related to a change in consumer taste; e.g. the rapidly increasing availability of high-definition content in the public broadcasting or cable network is likely to result in a change in demand $D-D'$.

In a competitive market it is often possible to give meaningful quantifications of *demand elasticity*. Demand elasticity is defined by $(dQ/Q)/(dP/P)$, as in Figure 4.2. Thus high elasticity of demand means that even small changes in price induce large changes in the quantity demanded. Often demand curves are convex, indi-

²⁵ Unlike most graphs in physics and the engineering sciences, supply and demand curves are normally plotted with the independent variable (price) on the vertical axis and the dependent variable (quantity supplied or demanded) on the horizontal axis. This tradition of economists is systematically followed in this report.

cating the common phenomenon that at the high end of prices the elasticity of demand is lower than at the low end of prices. (See Mankiw and Taylor 2006.)

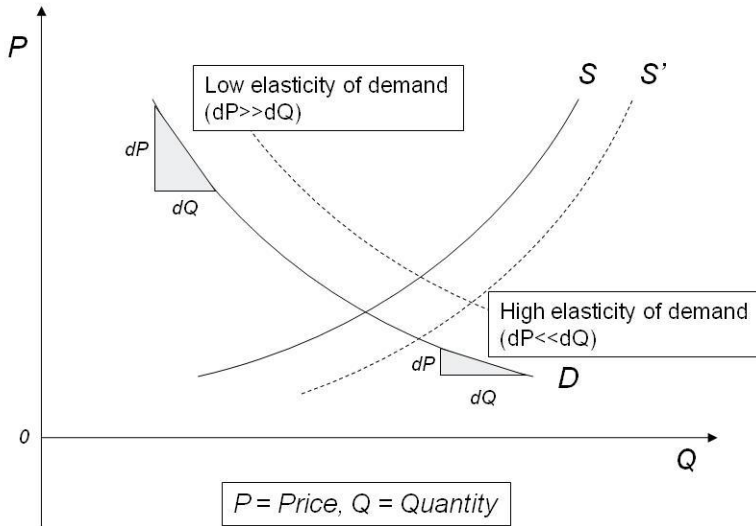

Figure 4.2. Elasticity of demand.

Figure 4.2 illustrates the *own-price* elasticity of demand, i.e. how a relative change in the price of the good changes the demanded quantity for that good. Similarly, a *cross-price elasticity* can be defined between two goods. E.g. if the price of cars was reduced by 10%, thus inducing more demand for cars, it would most likely also induce more demand for gasoline. Thus there would be *negative cross-price elasticity* between the price of cars and the demand for gasoline. Two goods are said to be complementary goods if their *cross-price elasticity* is negative. If two goods have positive *cross-price elasticity* they can be considered substitutes, e.g. margarine and butter. Logically, the *cross-price elasticity* of pulp wood and RCP should be positive, at least in the long term.

Figure 4.3 illustrates the concept of *composite demand*, which refers to the aggregate demand for a given good or utility in several end uses or markets (Marshall 1920, pp. 316–326). In the example there are three independent demand schedules, implying that, under the price N , the demanded quantities for the end uses are q_1 , q_2 and q_3 . At the highest prices only D_3 is active and when the price decreases D_1 and D_2 eventually activate.

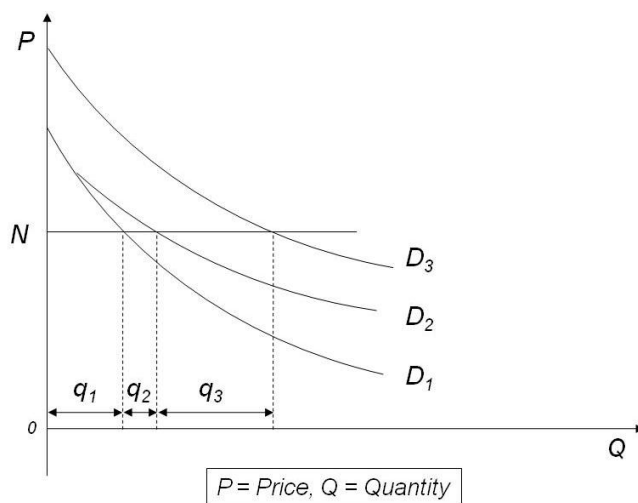

Figure 4.3. Composite demand as defined by Marshall (1920).

Analogously to *composite demand* we can define *composite supply* (see Figure 4.4). It refers to the aggregate supply of a given good or utility in several end uses or markets (Marshall 1920, pp. 316–326). In the example there are three independent supply schedules, implying that, under the price N , the supplied quantities from different sources are q_1 , q_2 and q_3 . At the lowest prices only S_1 is active and when the price increases S_2 and S_3 eventually activate.

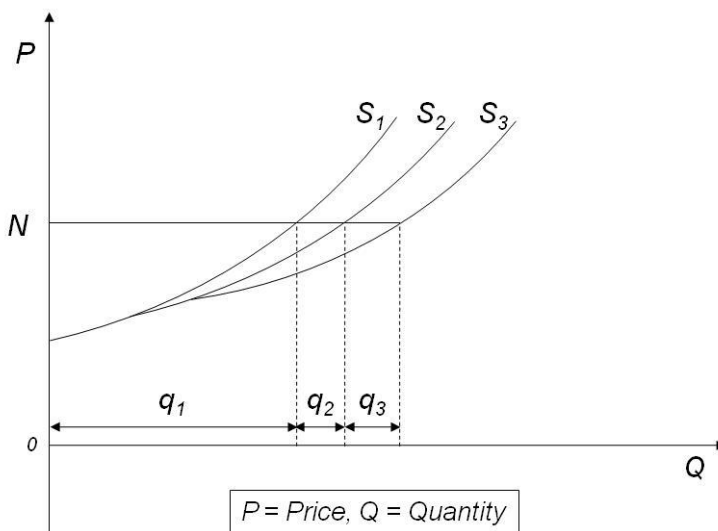

Figure 4.4. Composite supply as defined by Marshall (1920).

In theory, the total demand for recycled fibre in different end uses forms a composite demand for RCF and likewise the supply of recycled fibre for different end uses forms a composite supply. While the market mixes different qualities, traded at different market prices, and different physical forms of supply, the question remains how to visualise them in a single model so that the interplay between the different markets can be pinpointed?

4.2 Recovered paper (RCP) market overview

To date, the main active market for RCF has been its trade in the form of recovered paper (RCP). Almost all discarded paper that is not collected and sorted into commercial grades of RCP ends up either at landfills or in waste incineration plants²⁶. During recent decades, RCP has become the most important raw material in paper making, measured by volume. An overview of the price behaviour and development of the collection and utilisation of RCP over time is found in Appendix I to this study. More historical time series of a similar nature can be found for the US in Edgren and Moreland (1989) and for Sweden in Berglund (2004).

Pulp is generally known for its high price volatility, but the historical price volatility of recovered paper goes far beyond that of wood pulp. Edgren and Moreland compared the coefficient of variation (V)²⁷ between the real prices of wood pulp and wastepaper in the US and found that the former was $V = 15.4\%$ and the latter was $V = 40.5\%$ for the 1947 to 1985 period. Figure 4.5 presents more recent price statistics for pulp and recovered paper.

²⁶ It is often argued that waste incineration with any energy recovery is utilisation. In this study traditional waste incineration with max. 20–30% net efficiency in electricity generation and relatively low annual availability is paralleled with landfill disposal. From the purely economic perspective this is a fair comparison, as the clear majority of revenue comes from gate fees and the sold energy has only very minor significance (interview of Sipilä K. 2009).

²⁷ Coefficient of variation is defined as the relation of the standard deviation to the mean of the sample.

4. Modelling the supply-demand behaviour of recycled fibre

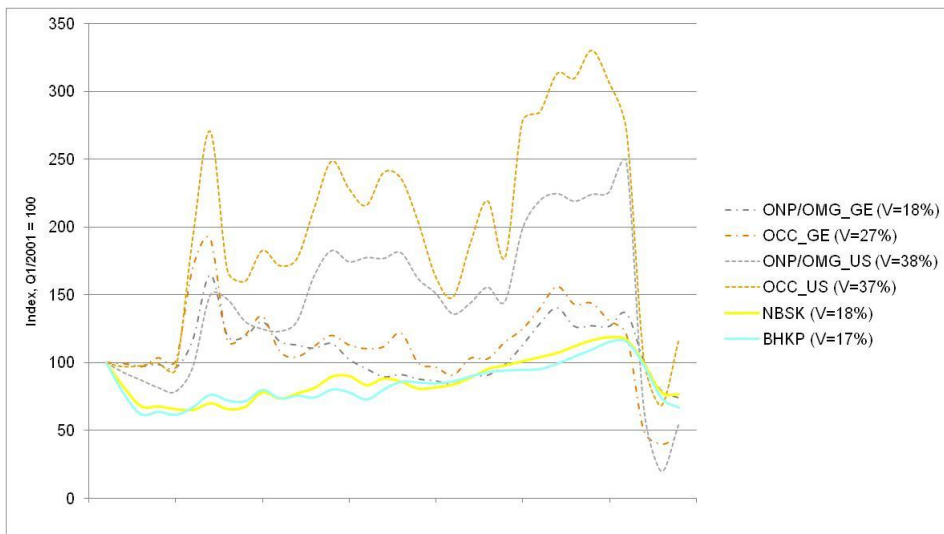

Figure 4.5. Indexed quarterly price development of pulp and recovered paper in 2001–2009. Nominal prices depreciated by 1.5% per year. Coefficients of variation are shown in parentheses. (Data by Pöyry Forest Industry Consulting and FOEX.)

The coefficients of variation for recovered paper vary quite remarkably between the German and US markets, tentatively indicating much higher elasticity of demand on the German market. The coefficient of variation for ONP/OMG on the German market is at the same level as for wood pulps (NBSK, bleached softwood pulp and BHKP, bleached hardwood pulp). It appears that price behaviour on the US market remains quite similar to the historical behaviour reported by Edgren and Moreland (1989), even if collection rates have roughly doubled since the mid-1980s when Edgar and Moreland ended their time series. One logical explanation could be the heavy exports bias in the US supply. On the other hand, net exports from Germany significantly decreased during 2001–2009 (Pöyry Smart Terminal 2011).

Finally, as a word of caution, it should be noted that the market for RCP is not a single homogenous market. In fact, the supply and demand for each RCP grade is directly connected to developments in the paper market, as certain types of recovered paper are primarily used in the production of certain types of paper, while a good amount of substitution possibilities remain as well. See Figure 4.6 below (adapted from Faul 2009). Just as the demand (and supply) pattern of different paper grades is not static, but evolves continuously, so the demand for different grades of recovered paper keeps changing. One can expect, for example, that as the majority of virgin fibre enters the system via office and printing papers, a relative decline in their demand will result in a tighter supply of OMG, MWP and MOW. As packaging boards are expected to increase their relative share of demand in the long term, and as the share of RCP in their raw material mix is high, this alone will create an increase in relative demand for RCP. Correspondingly, while the

consumption of newsprint is already declining, it will not greatly influence the RCP supply-demand balance, since the ONP grade circulates to a large extent within the newsprint production-consumption loop. Some amounts of the OMG grade could be expected to free up when the relative demand for newsprint weakens.

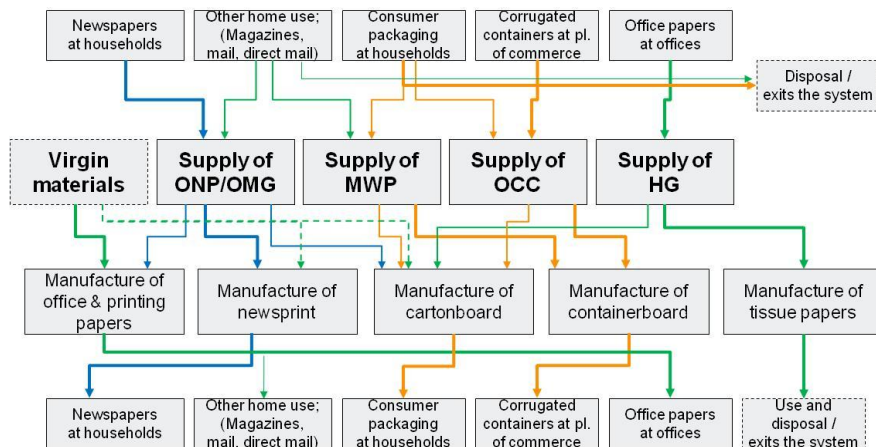

Figure 4.6. Simplified rotation of paper grades within the manufacture-use-recycle system.

4.3 Previous econometric analyses of the RCP market

As mentioned in the introductory chapters of this report, there have been several efforts to conduct statistically significant econometric analyses of the waste paper market. The earlier works were mainly based on US data, whereas the more recent analyses have often been based on Swedish data (Lundmark and Söderholm 2003, pp. 46–47). Different mathematical approaches have been used in these works – mostly various representations of Cobb-Douglas production functions, lately most often in the Translog form (Lundmark and Söderholm 2003, pp. 46–47).

Huttunen (1996) tables a wide array of qualitative factors affecting the supply and demand of RCP in the short and long term, and claims that RCP price fluctuations can be explained and anticipated. Her short-term demand factors include the availability and price of fibre substitutes, inventories, business volumes, regional price differences, end-product inventories, demand by other uses. Her long-term demand factors include production structures, capacity, utilisation and technology, raw material decisions, general fibre balance, capacity and utilisation on export markets, paper consumption, waste management problems and environmental legislation. On the supply side she mentions e.g. collection logistics and collection rate, and environmental legislation. The factors listed illustrate the wide array of factors affecting the RCP market, but she provides no guidance as to their quantitative relationships.

The earlier works consistently report very low *own-price elasticities* for both the supply and demand of RCP. Based on price indices and other US data, Gill and Lahiri (1980) modelled the supply and demand of wastepaper in the US. Regression analysis gave an own-price elasticity of 0.2 for supply and nil for demand. These figures are considered to be well in line with the high price fluctuations still experienced in the market (see section 4.2). The paper also finds that waste paper possesses the characteristics of an *inferior good*²⁸. Considering the overall volume development in the RCP market since the 1980s (c.f. Figure 1.1. and Appendix I) this clearly cannot generally be the case – although some examples are known today where consumers whose incomes are growing start to prefer higher-quality, more luxurious virgin-fibre-based quality in e.g. tissue paper and certain packaging (interview of Pehu-Lehtonen 2010). Concerning demand, significant cross-price elasticity was found for end-product prices and industry productivity, which would seem to be highly logical for any factor of production. The data in use was from 1952–1974, which is clearly dated considering today's truly global RCP market and the current collection rates that are perhaps already becoming saturated, at least regionally.

Edgren and Moreland (1989) analysed slightly more recent annual time series data from 1952–1981 to arrive at the supply and demand elasticity for wastepaper. Their finding was that demand elasticity is likely to be zero or, at maximum, slightly (0.0x) negative and that supply elasticity is likely to be very low, in the range of 0.06–0.08. The *elasticity of substitution*²⁹ between wastepaper and wood pulp was found to be about zero. They identified price up/downswings as elements of risk for the further development of paper recycling, especially for the suppliers of RCP. The prime question after E&M's convincing analysis is whether market conditions have profoundly changed since 1981 – e.g. the collection rate has more than doubled and recovered paper has become a truly globally traded raw material.

Nestor (1992) contributes to the body of econometric analyses by introducing the varying capital adjustment factor into the equations. The case studied is the demand for ONP for US newsprint production. She studies the elasticity of ONP demand in the short, medium and long terms by changing the capital adjustment factor in the model. In the short term capital is fixed, and in the long term it adjusts perfectly to its optimal level. In the medium term capital partially adjusts to its long-term optimal level. Nestor reports low *own-price elasticity* across the time horizon: short-term -0.05, medium-term -0.10–0.11, long-term -0.12. The most significant factors reported are -0.46 in short-term production output (perhaps due to the virgin-biased capacity base?), approx. -2 in the medium-term price of capital, and +3...+8 in production output (now positive because of enabled capital adjustment) and the same in the long term, but more pronounced. The elasticity of substitution

²⁸ *Inferior good* means that the demand of the good decreases by overall economic growth, as buyers shift to higher grade products.

²⁹ *Elasticity of substitution* is the elasticity of the ratio of two inputs to a production (or utility) function with respect to the ratio of their marginal products (or utilities).

between wood pulp and wastepaper grows significantly by the capital adjustment factor (0.2–0.8). The paper gives a well-reasoned picture of the (newsprint) industry. E.g., renewal takes place primarily by expenditures on capacity expansion, rather than by revamping the factor base of present assets. It would be interesting to apply Nestor's approach to the case of demand for OCC in the US linerboard industry in light of the lessons outlined in section 3.1 – the success story of US mini-mills.

Lee and Ma (2001) investigate the substitution possibilities between wood pulp and RCP through an econometric model. They propose a solution to the lack of price data on wood pulp that, almost without exception in the case of paperboard manufacturing, is integrated with pulp production. They find positive, but not really statistically significant, elasticity of substitution. They recognise the limitation of their approach, however, and suggest the use of empirical firm-level data for more detailed analysis.

Lundmark's (2002) and Berglund's (2003) doctoral theses consist of several papers touching on different issues in the waste paper market. Berglund looks at important inter-country differences in achieving recycling targets by means of econometric analysis, and questions whether universal targets are useful at all. Berglund also looks at the spatial cost efficiency of waste paper collection and concludes that universal targets should not be applied to densely and sparsely populated areas – simply from the point of view of cost efficiency. Lundmark discusses the impact of waste paper on the choice of location for investments, but, perhaps surprisingly, finds that investment decisions have no statistically significant correlation with waste paper availability and price. Nor does he find any other input factors having an impact.

Together with Söderholm, Lundmark provides a table summarising the elasticities reported from previous econometric analysis of the RCP (waste paper) market (Lundmark and Söderholm 2003, pp. 46–47). They find that the elasticities reported in the more recent studies tend to be higher than in the older studies and, furthermore, that their own grade-specific modelling of the Swedish market, based on mill-level data, yields considerably higher own- and cross-price elasticities than any of the previous works. The magnitude of the results is clearly different from earlier research, with short-term own-price elasticity over -1 for tissue, cartonboard and linerboard. Even for newsprint they report -0.61 own-price elasticity of demand for RCP³⁰ (!!). They propose that their finding could be explained by technical advances that have made RCP more widely utilised and that, consequently, this would have increased its price responsiveness. By dividing their samples into earlier and later time periods, they also get some support for this proposition. However, the data presented in Figure 4.5 suggests that there are some inherent differences in the price behaviour of the export-biased US market and the more

³⁰ This result is simply not in agreement with observations of RCP price behavior on the global market place. Such a high elasticity of demand would indicate far less price fluctuation than experienced.

balanced German market³¹. Sweden, on the other hand, is clearly a net importer of RCP and this could well have something to do with Lundmark and Söderholm's finding. But it is difficult to understand why the elasticities could be as different as was reported by Lundmark and Söderholm, unless the technical choices available at the Swedish mills providing the data really enable fairly straightforward optimisation between virgin fibre and RCP raw materials.

Samakovlis (2004) aims to revalue the hierarchy of waste management options for discarded paper by a dynamic general equilibrium model. Her conclusions question the present hierarchy of waste management policy, in which recycling is always prioritised ahead of energy recovery, especially in a country that has a substantial forest stock. Her dynamic general equilibrium model incorporates a trade-off between renewable forest assets and non-renewable fossil fuels. By making reference to the book of Virtanen and Nilsson (1993) she points out that (Samakovlis 2004):

- A recycling scenario leads to a lower total use of energy, but a higher use of fossil energy.
- The discarded paper content in MSW has a significant contribution in its fuel quality. Energy from incinerating waste paper would be a clean source of energy, if some of the chemicals and heavy metals used in pulp, paper and board and the printing process were replaced with more benign materials.

From the perspective of the technical and market developments in W-t-E explained in Chapter 3, the first statement of Samakovlis is now becoming out-dated. RCF-based papermaking no longer requires significant inputs by fossil fuels, as boiler investments designed to utilise both on-site generated rejects and miscellaneous refuse-derived fuels are taking the industry by storm. In fact, W-t-E applied in a paper mill environment provides about twice as much annual utilisation time in CHP as it would serving the district heating network in the Swedish example cited by Samakovlis (2004). The second observation still appears valid and underlines the research issue of this study – what will happen on the RCP market when increasing amounts of discarded paper are combusted among other wastes? Presumably there will be little interest on the part of W-t-E operators to sacrifice the discarded paper content in their fuel flows in favour of recycling.

Most of the past works on the economics of recovered paper concentrate on the notion of “how to prepare policy instruments that would most effectively encourage recycling at the least cost”, or whether it is “sensible to set universal recycling targets and favour recycling over energy recovery” (e.g. Huhtala and Samakovlis 2002). However, the whole theme of government intervention has now become obsolete in major parts of the global market. E.g. recovered paper collection in Central Europe and its supply to the paper industry works fully on a commercial basis, without remarkable subsidies. This is manifested by the interest of municipi-

³¹ High volatility naturally correlates with low price responsiveness.

palities in generating profits from this proportion of MSW flows – tenders for operating MSW under municipal control often include some form of stumpage cost for the collected RCP volumes (interview of Oikarinen 2010). It is true that smaller niches remain in the market, such as post-consumer packaging in remote areas where collection is not available yet, but which will divert from landfill streams by government intervention or market pull in the coming years (interview of Hellman 2010).

Past research in the field of econometric analysis is incapable of meeting the objectives of this research. The equations and mathematical approach can prove useful, but, in order to obtain a clear understanding of the basic phenomena in interplay between fibre and fuel, a simplified, qualitative model is called for. As Eisenhardt puts it, qualitative data helps the researcher to understand the rationale and reasons for relationships (revealed by the quantitative data) and may directly suggest a theory which, in turn, can be confirmed by quantitative means (Eisenhardt 1989, p. 538). A new approach is needed to understand the relationships between the different markets involved in the treatment and utilisation of discarded paper – while taking into account the possibility of fairly fundamental changes in future market conditions. Such a model can be used as a tool to analyse the composite RCF market, in order to meet the research objectives of this study.

The formal answer to Q3 is thus: Previous theories in the field of price theory and econometric analysis are not capable of providing clear answers to the research questions of this study.

4.4 Supply-demand model of the composite RCF market

4.4.1 Recovered paper market

Today, by far the most important segment in the composite RCF market is the market for conventional RCP grades. The recovered paper market can be considered a competitive market, as there are literally hundreds of buyers and sellers, meaning that each transaction has a negligible impact on the market price³². A large proportion of both buyers and sellers operate on the international market, which effectively reduces local variances in the traded qualities and market prices. Therefore the basic principles of price theory should apply to the market for recycled fibre. Furthermore, recycled fibre is a typical factor of production and its demand must be seen as derived demand, i.e. demand that is mainly dictated by external factors – in this case the demand for various paper grades and thus for their raw materials. The supply of recovered paper is a function of the paper consumed, the discarded paper collected and then sorted for purposes of sale as a commercial grade recovered paper. One could even think that the supply of re-

³² Regionally, there can be some important differences, as indicated by Figure 4.5 and the findings of an analysis of the Swedish market by Lundmark and Söderholm (2003).

4. Modelling the supply-demand behaviour of recycled fibre

covered paper forms, together with the supply of paper, a *joint supply*³³ in the sense that it emerges from paper consumption as a function of the collection systems.

If we try to apply the very basic supply-demand model to recycled fibre, we can see that the pattern of aggregate RCP demand³⁴ appears to have the shape and features illustrated in Figure 4.7. The demand curve D represents the quantity Q that the users of recycled fibre are ready to buy under the market price P . Obviously there are natural limits to both price and quantity on the market. The RCP price will never, on a sustained basis, exceed the price of the virgin fibre (P_{vf}), which is the raw material that RCP is actually a substitute for. On the other hand, the quantities will never, on a sustained basis, exceed the nominal capacity of the existing production assets capable of processing recovered paper (Q_{nc}) – even if the price were negative, as has been the case from time to time.

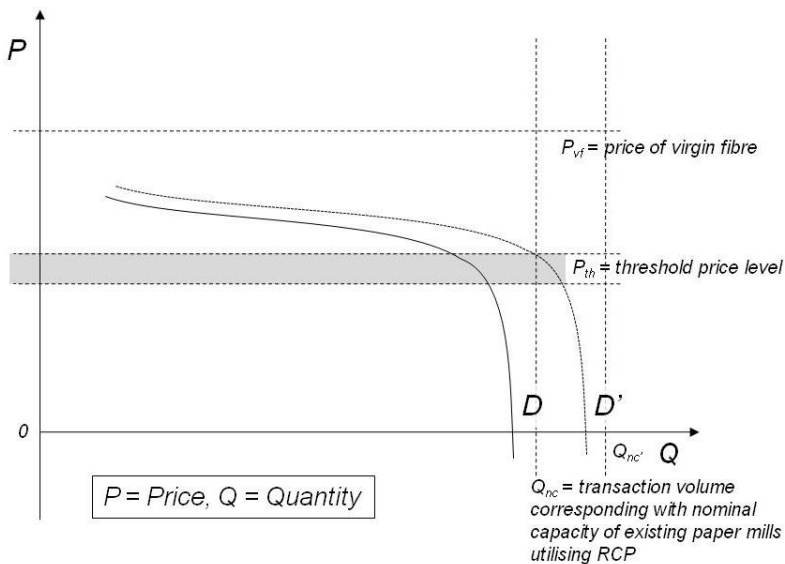

Figure 4.7. Aggregate demand for recovered paper.

³³ Marshall (1920) defines *joint supply* or *joint products* as things which cannot easily be produced separately, but are joined in a common origin, and may therefore be said to have a *joint supply*, such as beef and hides, or wheat and straw.

³⁴ Naturally, the RCP market is not a homogenous market, but consists of several different grades that command different prices in the marketplace. The generalisation provided in Figure 4.7 is for the marginal quantity of RCP traded and in practice corresponds with mixed waste paper. Other grades are traded at their individual market prices, above the price of mixed waste paper. For a more detailed explanation of this, see section 6.1.

When the RCP price starts to climb from its zero level, demand will first be very inelastic: papermakers will procure the raw material they need, regardless of the rising price, as RCP demand is de facto a *derived demand*. Then demand will slowly develop some elasticity, and at a certain point it will start to drop sharply (P_{th}). This threshold price level is the raw material cost level, under which individual mills gradually start to make a loss if other factors are constant. Because RCP demand is a derived demand, and because the demand for most paper products is derived from the demands of higher level end-products, the total behaviour becomes very complex. But, at some price level, the demand will level out. As the different RCP-utilising mills begin to make losses and are forced to curtail their production at different RCP price levels, and since the situation always varies to a large extent according to the RCP and paper grade in question, there will be a certain smoothness in the aggregate demand curve. Thus, in the short term, the demand for RCP in the normal area up to P_{th} will be fairly *own-price inelastic* (perhaps up to -0.1) and will become very elastic in the range $P_{th} - P_{vf}$.³⁵

In reality, it is of course questionable whether the demand for RCP could ever reach Q_{nc} , even if RCP was available for free. However, in the longer perspective, the supply-demand balance of waste paper has a definite influence on the investment decisions on new or modernised paper making capacity (resulting in a demand shift $D-D'$) and on the RCP market prices experienced (see Figure 4.8). These dynamics appear to be quite slow, but in practice new major investment decisions (and thus start-ups of new or revamped facilities) are made monthly, if not weekly, on a global basis. Obviously, as in any market, neither the demand curve nor the supply curve remain static for a longer period but are in constant change.

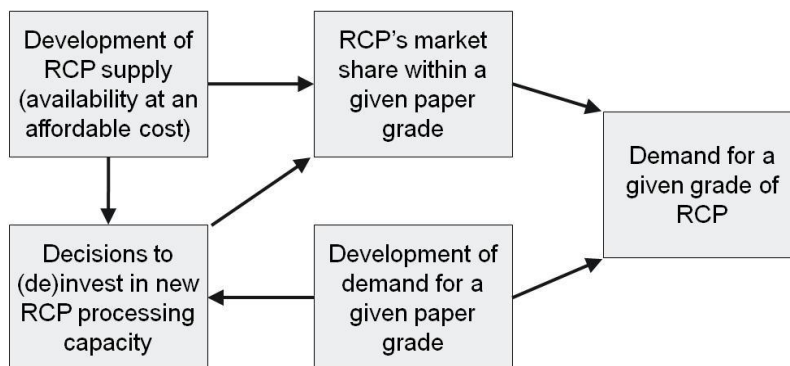

Figure 4.8. The most important factors causing a demand shift for RCP.

³⁵ One possible explanation for the contradictory results of Lundmark and Söderholm (2003) is that the relative price level of RCP has increased over time. According to Appendix I there has been growth in its real price, whereas in the same time period the real price of both virgin pulps and paper products has gradually decreased. As a result, RCP has probably increased its price responsiveness over time.

4. Modelling the supply-demand behaviour of recycled fibre

Figure 4.9 illustrates some essential features of the recovered paper supply schedule. The supply curve S represents the quantity Q that the RCP traders are willing to supply for the price P . Again there are certain natural limits to both price and quantity³⁶.

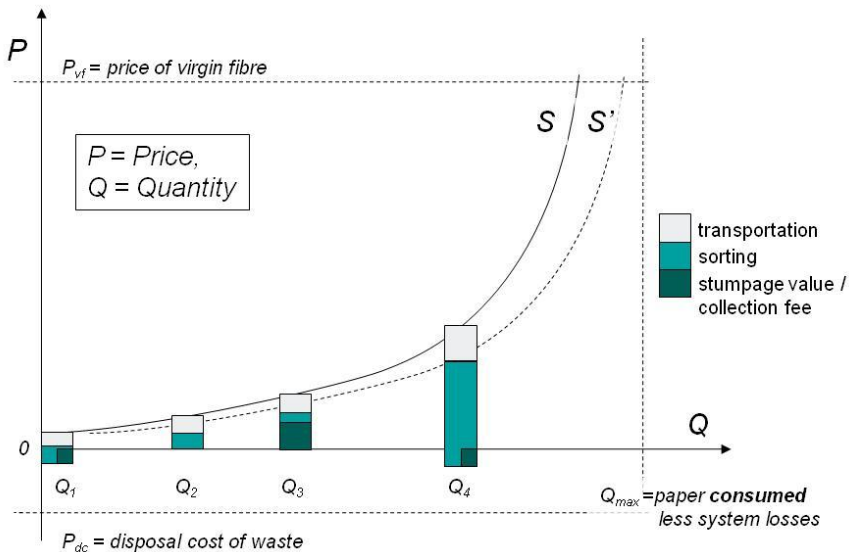

Figure 4.9. Aggregate global supply of recovered paper.

By definition, the supply schedule represents the aggregate marginal cost curve of the suppliers. The manufacturing cost structure of different suppliers or quantities is respectively dependent on the stumpage price of different sources (sometimes negative, i.e. a collection fee), the transportation cost and the sorting cost. As an example, the quantities Q_1 – Q_4 in Figure 4.9 illustrate clearly different cost structures – some are transportation-biased, some are sorting-biased, and some have negative, zero or positive stumpage values. The theoretical maximum quantity of supply Q_{max} is limited by the quantity of paper consumed less system losses, including e.g. the net increase in archives, and the quantity disposed in sewers and in domestic fireplaces.

At the low end of prices the supply is first highly elastic, and the quantity supplied develops rapidly since the supply is based on flows that require minimum sorting. Because a large percentage of the total RCP quantities can be readily collected in quite acceptable purity for commercial use, the elastic area tends to form quite a large portion of the total available quantity. Eventually the supply

³⁶ Analogically to the demand, the generalisation provided in Figure 4.9 is for the marginal quantity of RCP traded and in practise corresponds with mixed waste paper.

starts to develop inelasticity because the cost and possibilities to technically and economically sort commercial RCP grades out of the available waste streams narrow rapidly. In other words, the marginal cost starts to increase gradually as the waste management company has to extend the sorting to increasingly mixed waste streams.

As recovered paper is always waste to somebody, the market may from time to time express behaviour that is not within the framework of normal price theory. In situations of a sudden drop in demand, it might occur that nobody is interested in paying (or even accepting a lot of RCP with money) and that the waste management company, being ultimately limited by its warehousing capacities, is obliged to dump the lot of RCP somewhere, even at a loss³⁷. In such a rare demand situation, the alternative is waste disposal in a landfill or a waste incineration facility. The disposal cost P_{dc} is the gate fee required by the landfill or the incineration facility, and it sets the lowest theoretical limit for the price and is clearly negative. As a result, in light of the statistics of price behaviour, the supply is highly *own-price inelastic*.

Naturally, as collection rates and sorting methods keep improving, the supply curve tends to move right ($S-S'$). On the other hand, if demand is strong and the market price stays high, the owners of waste, e.g. retail shops and municipalities, will tend to start bargaining over stumpage cost, thus moving the supply curve up. Today's highly competitive business environment ensures that the stumpage cost level actually follows the changes in RCP market price quite closely, thus effectively changing the elevation of the curve – at least for those quantities that are not affected by long-term contracts (interview of Oikarinen S. 2010).

Figure 4.10 makes an attempt to portray the above-presented supply and demand curves on the same chart, in the same way as in the general price model depicted in Figure 4.1.

³⁷ E.g. during the financial crisis of late 2008 / early 2009, the prices of RCP temporarily dipped below zero (trade press information).

4. Modelling the supply-demand behaviour of recycled fibre

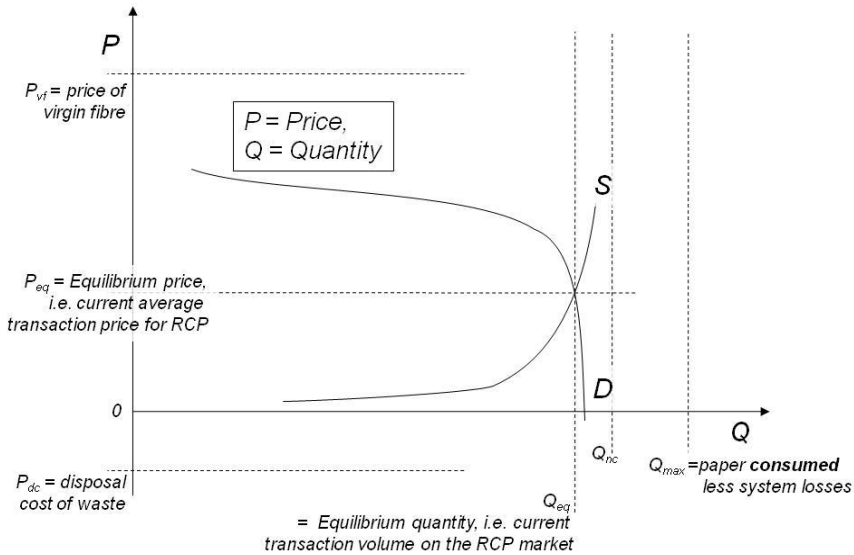

Figure 4.10. Aggregate supply and demand of recovered paper.

In this illustration the supply and demand curves find their equilibrium at P_{eq} (i.e. the current transaction price for the marginal quantity of RCP) and at Q_{eq} (i.e. the current transaction volume on the RCP market). The balance lies in the area where both curves are in their highly inelastic phase, thus indicating great price volatility in response to shifts in either supply or demand. This basic model is in line with the previous econometric analyses of the RCP market as reported in the previous chapter and with the historical price development as described in Figure 4.5. The history includes periods of weak demand (e.g. 1990–1993, 1996–1999 and 2008–2009), when the demand curve suddenly shifted radically to the left, leading to periods of negative marginal prices for RCP. Similarly this history includes periods during which the investments in new recycled-fibre-based papermaking capacity surpassed the more gradual development of the supply (e.g. 1994–1995, 2000–2002 and 2007–2008). Such periods of tight supply have resulted in rapid price increases.

4.4.2 The interplay with the RCP and other markets

The previous section discussed the main features of the RCP market. What happens to the discarded paper quantities between Q_{eq} and Q_{max} in Figure 4.10? They are partly utilised as energy, but mainly disposed at landfills or mass incineration

facilities^{38, 39}. The main objective of this research is to study the interactions between these and the RCP market.

Figure 4.11 presents the proposed general model of composite RCF supply and demand – in its different physical forms. This model gives an overview of the potentially intertwining and overlapping markets of RCF in its different end uses (which respectively tolerate different physical forms). In this general and simplified model the supply and demand of RCF split into three *cascaded main components*: a) as recovered paper – RCP, b) as fuel – e.g. SRF⁴⁰ and c) as waste to be disposed of e.g. in landfills or in waste incineration plants – MSW. In the graph these quantities are respectively marked as Q_{RCP} , Q_{SRF} and Q_{MSW} .

This three-component cascade-model is obviously highly simplified. In reality, RCP alone is naturally not a homogenous market, but is traded in different commercial qualities, all with individual supply and demand schedules. These sub-markets of RCP are explained in more detail in section 6.1 where a numeric example of the model is presented. The P_{RCP} in this model represents the price of the marginal quantity Q_{RCP} . In practice this is the market price of the mixed waste paper.

³⁸ As explained in the introductory Chapters of this report, there are some other minor uses for discarded paper such as in insulation materials, in molded products or as animal beddings. Altogether, these uses consume a maximum of 4–5% of discarded paper (Stawicki and Read 2010).

³⁹ As discussed earlier, most mass incineration facilities also produce some energy output, but their operations are de facto financed by the collected tipping fees. That's why they are paralleled with disposal in the context of this study.

⁴⁰ In context of the proposed S/D-model this study uses systematically the term SRF for reasons of clarity. While the fuel market is presently not at all a homogenous market this simplification is considered useful to analyse possible interaction between the low-end of the fibre market and high-end of the fuel market, i.e. the SRF market. Further, in comparison to the more general term RDF it has the advantage of clear specifications and therefore a possibility to develop characteristics of a product traded at a competitive market.

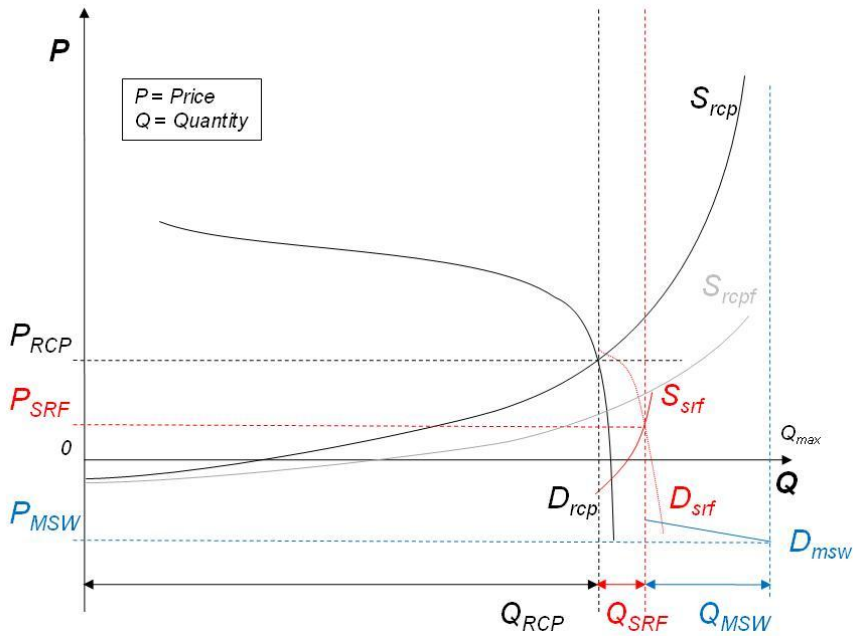

Figure 4.11. General model of the composite demand and supply of RCF.

The total RCF content in these flows (Q_{MAX}) corresponds with the total amount of paper consumed less net increase in archives, less quantity disposed in sewers, less quantity burned in domestic fireplaces and similar unrecoverable losses. In other words, the total available RCF quantity is fixed (by consumption), and only the split in the amounts appearing on these different markets varies according to the current demand and supply curves on the different markets. Together the total RCF content in these quantities makes up the total available volume of RCF ($Q_{RCP} + Q_{SRF} + Q_{MSW} = Q_{MAX}$).

Whereas each ton of RCP also carries a small amount of foreign non-fibrous material, each ton of SRF carries not only the RCF content of the fuel, but also at least a similar amount of other combustible materials and a small amount of non-combustible impurities. In MSW today, one finds quite a small amount of RCF, but a lot of other trash. In other words, by the definition used in this model, Q_{SRF} represents only the RCF content in the SRF flows and is therefore only less than half of the total tonnage of SRF traded today. Similarly the Q_{MSW} of this model represents probably less than a third of the total MSW tonnage disposed. For simplicity, this model applies the SRF price equally for the all material fractions found in it.

The model described in Figure 4.11 shows how the price and quantity in each of these markets is defined by the balance of the respective supply and demand, i.e. the intersection of the S and D curves. In other words Q_{RCP} is traded at P_{RCP} based on the balance of supply and demand. The demand for RCF as RCP, D_{RCP} ,

depends on the demand and price of different recycled paper products and the paying capacity of their downstream value chains. This paying capacity is also affected by the prices of other factors of production in paper making and the quality of the installed manufacturing capacity base. As a result, the total paper industry displays a certain demand for RCP (D_{RCP}). The RCP-supplying companies respectively display a certain supply curve that in theory equals their marginal manufacturing cost curve and, at a given point in time, these curves intersect at Q_{RCP} , P_{RCP} . This is the equilibrium point at which the market will settle, if all conditions are constant.

The margin of Q_{MAX} and Q_{RCP} in Figure 4.11 remains to be split between the fuel and waste disposal markets. Here, D_{SRF} is the demand curve displayed by the potential users of refuse-derived fuels for material flows suitable for use as fuel. The shape of D_{SRF} reflects the paying capacity of the different power plants (and today the very few chemical conversion facilities) for the refuse-derived-fuel flows that carry the discarded paper or RCF content according to the values of the Q axis. In this model, the value of RCF within a given SRF flow can be considered equal to its other components; i.e. all components in SRF share the same average price per ton. The shape of the supply curve S_{SRF} comes from the marginal manufacturing cost curve of the suppliers of these flows. Thus, the intersection of S_{SRF} and D_{SRF} dictates the quantity and price of RCF traded as SRF (Q_{SRF} and P_{SRF} , respectively). Here we note that the actual size of the SRF market remains at least double – when we add up the tonnage of other material fractions included in SRF.

The remaining margin between Q_{MAX} and $Q_{RCP}+Q_{SRF}$ stays on the MSW market. In this model not much attention is paid to the MSW market. It is simply assumed that there is indefinite demand, i.e. sinks for waste either as landfills or in waste incinerator plants. The demand curve for waste disposal (D_{MSW}) is therefore essentially flat and in Europe lies somewhere at a price level of -100 €/t (interview of Hietanen L. 2009). In other words, in the model described above, all RCF content that is not sorted or processed out of the different waste flows either as RCP or as SRF remains to be disposed of, and the price level of this service (i.e. the tipping fee) in Europe is somewhere around -100 €/t.

Let's next have a new look at the supply curve of RCP, now depicted as Figure 4.12. As explained under section 4.4.1 the manufacturing cost structure of different suppliers or quantities is respectively dependent on the stumpage price of different sources, the transportation cost and the sorting cost.

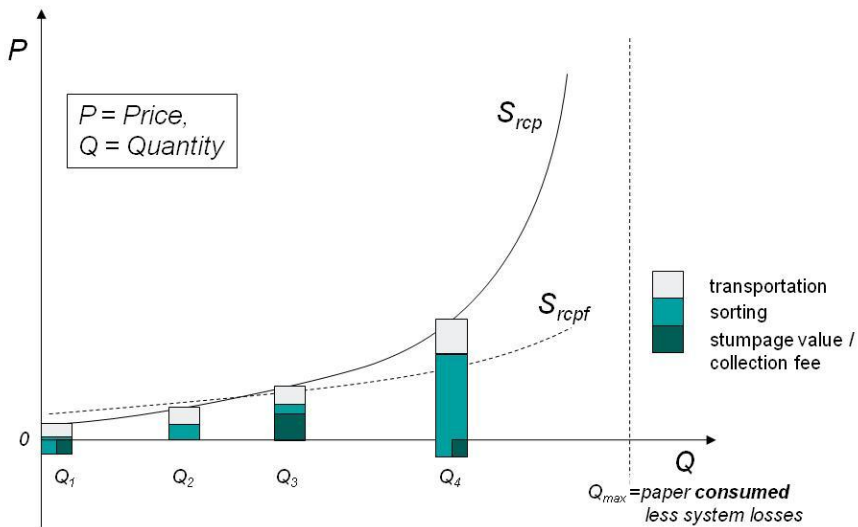

Figure 4.12. Illustration of typical cost structures behind RCP Supply-curve (S_{RCP}).

In addition to showing the supply curve of RCP, Figure 4.12 displays its **shadow curve**, the manufacturing cost curve of RCP as fuel (S_{RCPF}). In theory, each quantity traded to the RCP market could be traded on the fuel market, typically at somewhat lower cost. The difference in the manufacturing cost S_{RCP} and S_{RCPF} consists mainly of the reduced need for sorting and the somewhat simplified collection, i.e. lower transportation cost. On the other hand, delivery to the SRF market requires size reduction (shredding of the material) that, for some quantities, is probably more expensive than the savings in sorting cost.

This means that the supply curves S_{RCP} and S_{SRF} of Figure 4.11 are connected through the S_{RCPF} . Consider a waste management operator handling a given lot of material, rich in discarded paper, but containing a relatively large proportion of foreign material, most of which is combustible. It may decide to just skim the easiest fraction of the material lot by sorting it into a given grade of RCP and putting the rest of the material into the SRF market, or, based on market conditions (demand and consequently price), it may decide to devote much effort and cost to sorting the maximum amount of RCP out of the material lot and to produce hardly any tailings for the fuel market. At the other extreme, the WM operator could even combine the collection of this flow with some of the fuel fractions requiring less sorting, and thereby make savings in the transportation/collection cost.

Together with the principle of displaying all discarded-paper-containing quantities against Q_{MAX} , this connection of S_{RCP} and S_{RCPF} is the central element of the proposed RCF supply-demand model. S_{RCPF} reflects the manufacturing cost of fuel from the flows normally sorted and sold as RCP. Typically, the difference in manufacturing cost between S_{RCP} and S_{RCPF} is the additional sorting needed to perfect a given flow into a commercial RCP grade (adjusted by the shredding

cost). Logically, this gap tends to increase the closer we get to Q_{MAX} , i.e. as the flows become increasingly costly to sort into commercial-quality RCP.

In this cascade model, *the markets for RCF as RCP and as SRF stay separate as long as there is no producer's surplus available on the SRF market for the marginal quantity Q_{RCP}* (which by definition commands a zero producer surplus on the RCP market). In Figure 4.11 the price of SRF, P_{SRF} is still below S_{RCPF} for the marginal quantity Q_{RCP} , and no mix between the two markets takes place.

As these different markets continuously develop, it means that each supply and demand curve is continuously changing position vis-à-vis the other, and is also slowly changing shape. Naturally, big regulatory moves, such as taxes and subsidies, can cause rapid movements in the position of these shapes. Two examples could be landfill tax or CO₂ credits for the renewable share of the waste-derived fuels.

The following three charts conceptually illustrate what takes place when the RCP and SRF markets develop in relation to each other in three steps.

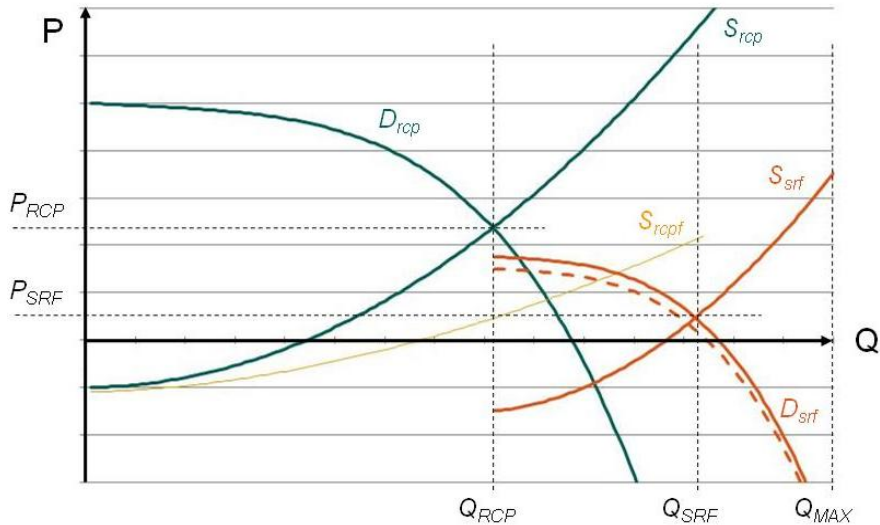

Figure 4.13. Step 1: The SRF and RCP markets develop into a state of equilibrium.

In Figure 4.13 the solid line D_{SRF} describes the increase in the fuel demand up to the point where P_{SRF} and Q_{RCP} intersect at S_{RCPF} . In other words, the marginal Q of RCP commands the same zero surplus, whether sold on the fibre or fuel market.

4. Modelling the supply-demand behaviour of recycled fibre

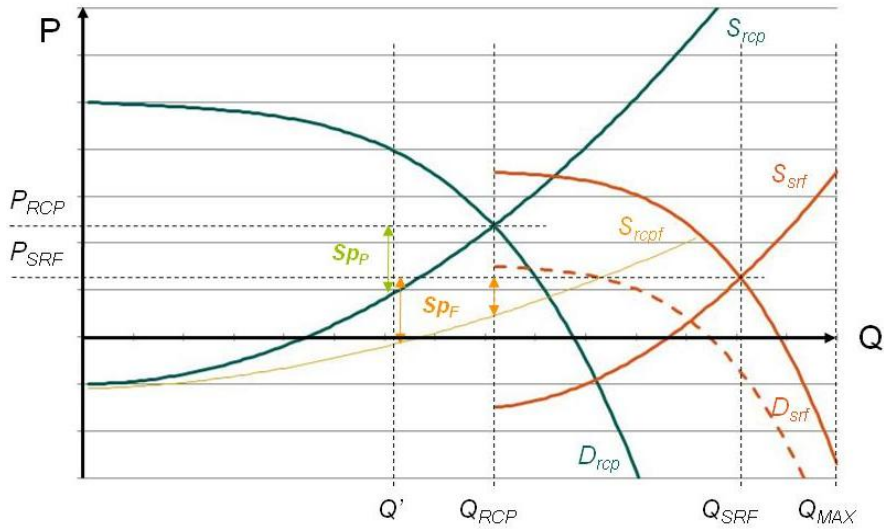

Figure 4.14. Step 2: Surplus opportunity for the marginal RCP quantities on the fuel market.

In Figure 4.14 the D_{SRF} increases still further, so that the marginal Q of RCP (Q_{RCP}) will yield a clear surplus if prepared and sold on the fuel market (Sp_F). All quantities beyond the Q' – where the surplus of RCP on the paper market (Sp_P) matches the one on the fuel market (Sp_F) – are under threat of moving to the fuel market.

In Figure 4.15 a new balance is reached where a slight bleed of RCP ($Q' - Q_{RCP}$) from the fibre to the fuel market causes some increase in the RCP price and a corresponding decline in SRF prices. Now the system is back in balance; i.e. the marginal quantity of RCF on the paper market again has a zero surplus on both the paper and fuel markets. Thus, in a bleed situation, the relatively inelastic supply and demand schedules for both RCP and SRF should effectively buffer the system.

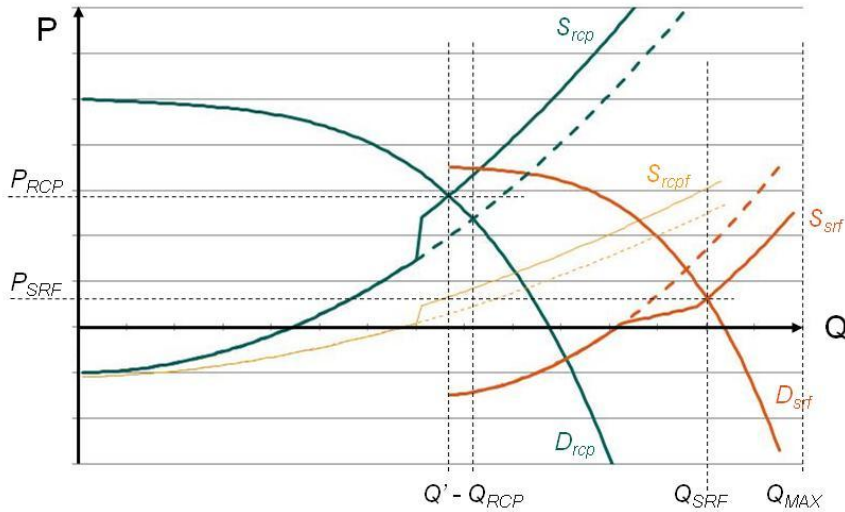

Figure 4.15. Step 3: Bleed to SRF market results in a new balance.

4.4.3 Summary of hypotheses related to basic market phenomena

This section summarises the hypotheses concerning how changes in the market conditions will be reflected by changes in the various demand and supply schedules in the composite model described in the previous section.

A) Development of demand for RCP

Demand for RCP develops in the long term by investments in RCP utilisation capacity (such investments that increase RCP's market share in the papermaking raw material mix). Such development moves the RCP demand curve to the right. If investments in virgin fibre capacity are made in excess to the RCP utilisation capacity, D_{RCP} moves to the left.

Typical short-term changes in the operating rate of the industry can be interpreted as changes in the paying capacity of the utilising industry, and are reflected mainly by vertical movements of the demand curve.

All-in-all the demand development for RCP is ultimately based on the development of upstream demands for different paper products, including the effects in the markets for other factors of production. Therefore the shape and elevation of the demand curve are in continuous but relatively slow change.

B) Changes in the virgin fibre (substitute) price

Changes in the virgin fibre price will change the elevation of the demand curve, *ceteris paribus* – if no capital adjustment is allowed. For instance, if the price of virgin fibre rose, it would eventually improve the paying capacity of the utilising

4. Modelling the supply-demand behaviour of recycled fibre

industry for the recycled fibre without, as such, introducing any additional RCP treatment capacity to the market, i.e. without moving the demand curves on the quantity axis.

C) Development of RCP supply

Development of the RCP supply takes place by improving and extending the collection, and by investments in sorting plants; i.e. by improving the retention of current collection schemes and by establishing new collection schemes.

As a generalisation, establishing new collection schemes moves the RCP supply curve to the right, while improvements in the collection and sorting systems impact the shape of the supply curve.

The stumpage cost is an element in the cost structure of suppliers that is not static at all, but lives in connection with the RCP market price. In practice, merchants bid for discarded paper quantities at source, e.g. they might bid for the baled OCC of a supermarket chain, or for a contract with a given municipality for household collection. When the RCP market prices change, the price level of the bidding (stumpage cost) changes accordingly. Often the bids determining the stumpage cost are much longer-term than the changes in the RCP price on the market. The RCP supply schedule should acknowledge this phenomenon.

D) Development of the shadow supply-schedule (RCP as fuel)

The shape of this curve is dependent on the collection and sorting systems in place and the ways that they can be used in simplified form for production of the fuel grade. Each quantity in the S_{RCPF} schedule has its counterpart in the S_{RCP} schedule.

E) Development of SRF demand

Development of demand for SRF takes place by investments in modern waste-to-energy facilities that require quality-controlled, reasonably homogenic and high calorific waste flows. These investments move the demand curve to the right.

Different subsidies and taxation benefits have the potential to move the demand curve in the vertical direction, causing rapid changes in the equilibrium price of SRF.

F) Development of SRF supply

Development of supply of SRF takes place by investments in collection schemes and sorting capacities, and improvement of the retention of current schemes. Such development moves the supply curve to the right. Improvements in the systems will also slowly change the shape of the curve. Moreover, if any bleed takes place from the paper market to the fuel market, it will change the shape of the SRF curve as shown by the example of Figures 4.13–4.15.

In order to achieve valid foresight into the development of the RCF market, one needs to consider all these factors (A to F) that are relevant in the developed

three-component cascade model for the composite RCF market presented in this chapter.

Answer to the research question Q4 – What does the model of the composite RCF market look like?

Section 4.4 has provided an initial answer to the research question Q4 by outlining the qualitative characteristics of the supply-demand model of the composite RCF market. The model builds on the basic concepts of composite supply and demand by Marshall, but develops them by proposing a three-component cascade-model. The tie-in of the cascaded fibre and fuel markets is made possible by two new concepts, Q_{MAX} and S_{RCPF} . In the proposed model, each quantity is presented by the weight of its discarded paper content, summing up to the Q_{MAX} , the maximum attainable quantity. Furthermore, the shadow supply schedule of RCP as a fuel (S_{RCPF}) makes it possible to compare the available surplus on the fibre and fuel markets for the marginal RCP quantities.

The final answer to Q4 will be provided through testing and further refining of the model in the next chapters.

5. Delphi study on the supply-demand behaviour of recycled fibre

The objective of this chapter is to define answers to the following research questions by exploring the results of a Delphi study:

- Q5: What phenomena are likely to affect the RCF market in the future?
- Q6: Are any such market phenomena likely in the future that might suggest increasing interplay between the markets for the use of discarded-paper-containing flows as raw material and as fuel?

5.1 Description of the Delphi study

In the course of the research it was deemed necessary to generate an expert opinion on likely developments in the composite RCF market, especially in the light of increasing investments in bioenergy in general and in waste-to-energy at paper mills in particular. A Delphi panel was identified as a potential scientific method to achieve this (c.f. Chapter 2).

The Delphi study serves several important purposes in this research. Its objectives were formulated as follows:

- i. to gain support and evidence for the constructed S/D model; to iterate the model as needed
- ii. to gain qualitative insight on the phenomena likely to affect the RCF market in the future
- iii. to create a basis for preliminary quantification of the model.

The pre-identified trends, summarised in Table 3.4, and a preliminary S/D model formed the basic set-up for the panel. The letter of invitation and the problem description of the Delphi study are included as Appendix II to this report.

Figure 5.1 presents an overview of the Delphi study on the supply-demand behaviour of recycled fibre. The expert panel was conducted in two rounds: the first round of the study consisted of face-to-face interviews of all 15 panellists and was carried out during February-September 2010. Each interview consisted of an

open-ended discussion of the study themes, followed by a structured section where each panellist was requested to give her/his opinions on the development of selected key trends together with the relevant argumentation. A combined interim report and questionnaire for the second round was distributed at the end of September 2010. Written responses were received from all the panellists by the end of November 2010 and a report on the second round was distributed in December 2010 for further comments.

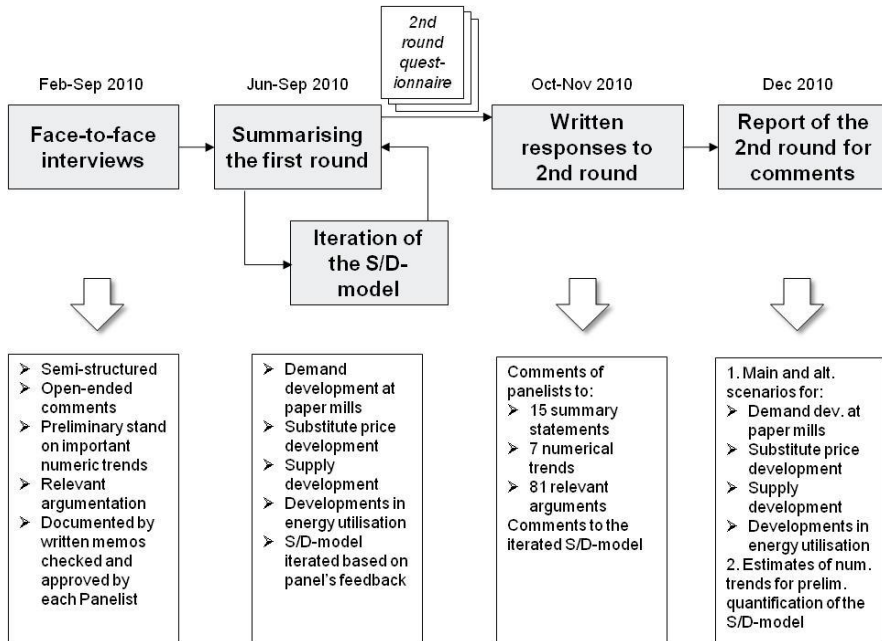

Figure 5.1. Overview of the conducted Delphi study.

The Delphi panel is not an opinion poll. It is an attempt to create a balanced and well-argued view of the likely developments and also to identify alternative scenarios for the market development. The averaged opinions of the panellists have little value, but those viewpoints backed by the strongest arguments will be given the most attention in interpreting the results of the panel. In this respect the second round of the panel is particularly important, as it contains all the argumentation presented in the first round interviews and encourages the panellists to further clarify their own arguments and to challenge those of the others.

The rather narrowly focused topic and required areas of expertise enabled the panel to be put together from relatively few people. There were 15 panellists in all, including a specialist in scientific foresight who provided the needed methodological guidance in the study. Table 5.1 summarises the composition of the panel based on areas of expertise, types of expertise and industry background. The

5. Delphi study on the supply-demand behaviour of recycled fibre

areas of expertise were jointly defined with the panellists. The types of expertise are based on the author's assessment according to typology provided by Kuusi (1999), c.f. section 2.3. The industry backgrounds represented included two sectors that presumably had a degree of conflicting interest, i.e. pulp and paper (P&P) and waste management (WM). The others included experts employed by research institutes and multi-sector consultancies. Due to their background in the study field, all panellists were familiar, at least in broad terms, with technical developments in the W-t-E sector, as described in Chapter 3. Several of the panellists can even be considered to be among the leading global experts in the themes in question. In fact, the objective of the panel was not to present arguments on the technical feasibility of the concepts of Chapter 3 that were used as examples in the discussion, but to create reasonable arguments for the likely market development.

Table 5.1. Classification of the panellists.

	Areas of expertise [X = primary area, x = secondary area]					Type of expertise [acc. to Kuusi 1999]			Industry background		
	a)	b)	c)	d)	e)	§1	§2	§3	P&P	WM	Other
1					X			(x)			(x)
2	X	x				X		X	X		
3	x	X				X		X			X
4	x		X			X		X			X
5		x	x	X		X		X			X
6		x	x	X		X					X
7		x	x	X		X				X	
8			X	x			X			X	
9	x		X	x		X			X		
10	x		X			X			X		
11	X	x	x				X		X		
12			x	X		X				X	
13		X				X	X		X		
14	X	x		x		X		X	X		
15	x	X					X		X		
<u>Areas of expertise</u>					<u>Types of expertise</u>						
a) Volume development of the utilisation capacity					§1 Scientists						
b) Price development of the substitute (=virgin fibre)					§2 Decision-makers						
c) Volume development of the collection					§3 Synthesizers						
d) Price development in alternative utilisations (i.e. outside papermaking)											
e) Methodological advice											

Because of the highly condensed panel, the first round of the study could be carried out in the form of semi-structured, open-ended face-to-face interviews. The interviews were recorded in written minutes by the Delphi manager and distributed to each panellist within a week of the interview for corrections and approval. Four of the panellists were based in Germany and the rest in Finland, although all had substantial international experience, enabling at least a European perspective in the responses.

The main findings from the first round were returned to the panellists in the form of a structured questionnaire presenting the main findings in the form of 15 summary statements, 7 numerical trends and 81 specific arguments, grouped into those that supported each given trend and those that opposed it (see Appendix III). The panellists were requested to respond to at least those statements, trends and arguments in their specific area of expertise. If they did not agree with a given statement or argument, they were requested to specify the reasons why. Thus the panellists were encouraged to elaborate on their views and were also given the possibility to revise their statements. Only one panellist did not fully respond to the second round questionnaire, preferring to provide very brief comments instead.

The author's summary of key results (see section 5.2) and the detailed results of the second round (Appendix IV), were returned to the panellists in a final report which the panellists were encouraged to comment on, if they found any of the conclusions invalid. This constitutes a voluntary third round of the panel, and effectively confirms the conclusions arrived at. The third round produced no spontaneous reactions, but the Delphi manager decided to contact a couple of panellists to directly clarify the background to a couple of issues.

The conducted study combines *option reasonability* and *predictive reasonability* (Kuusi 1999, pp. 116–121). It is a mixture of Trend Delphi and Argument Delphi (ibid., pp. 128–134). It is exploratory by nature, and covers both qualitative and quantitative aspects of the topic.

5.2 Key results of the Delphi panel

In the following, the key results of the Delphi panel are grouped under four main headings:

1. Demand development of RCP at paper mills
2. Substitute price development
3. Development of RCP supply
4. Market development related to the energy utilisation of RCF.

The main market phenomena, A–C, as identified and labelled in section 4.4.3, are directly represented under the first three headings. The rest of the items, D–F, are handled together under the 4th main heading. This compromise reflects the lack of numeric, quantifiable data related to the D–F items. The expert opinion gained on these items is at a fairly general level, with item D, the shadow supply schedule of RCP as a fuel, being especially weakly covered.

5.2.1 Demand development of RCP at paper mills

The panellists generally agreed with the following summary statements presented on the basis of the first round interviews (see Appendix IV, detailed results, p. 2):

S1.1: Growth in utilisation of RCP will continue.

5. Delphi study on the supply-demand behaviour of recycled fibre

- S1.2: Technical developments in RCP and RCF processing will continue to create room for an increase in demand.
- S1.3: Market development in the export markets, mainly China but also India and the other Asian economies suffering from a fibre deficit, will be the decisive component in demand development. European development will play a clearly smaller role.
- S1.4: In the short term, the operating rate of paper mills is the most important factor setting demand for RCP, whereas its price has only a small impact. The current perception is that the price of RCP will remain high for quite some time, due to its tight supply.

Thus the *main scenario* related to demand development of RCP at paper mills is that the growth in utilisation of RCP will continue, at least for the time frame of this study (up to 2020). This development will be driven primarily by demand on the “export markets”, i.e. China, India and the other Asian economies suffering from a fibre deficit. This means that development of the local utilisation rate in Europe (and in North America) will play a lesser role in the development of the demand-supply balance.

Technically, most printing papers can significantly increase their RCP utilisation, and this technical development is expected to continue. However, it is quite another question whether market conditions will allow the uti-rate in printing papers to increase. The responses received to argument #8 (A8), for example, actually hint that the uti-rate in printing papers will not grow anymore, because of poor availability. (See Appendix IV, detailed results, p. 6.)

The comments of the panellists were in line with the assumption of low *own-price elasticity* of demand. The current perception is that the price of RCP will remain high for quite some time due to tightening supply and brisk demand from the export markets. There also appears to be a tendency for the stumpage cost of RCP to increase, meaning that municipalities will increasingly ask for a share of the RCP sales price as part of collection contracts. This will cause pressures in the marginal costs of RCP suppliers and thus a general tendency to elevate the position of the supply curve, S_{RCP} (c.f. Figure 4.11.).

There were some comments suggesting that the poor availability of RCP has already started to discourage RCP-based investments and that European players with the ability to choose between TMP and ONP are already picking TMP. This is an indication of a bend in the demand curve, D_{RCP} (gradually increasing elasticity), at the current high price levels of ONP/OMG (approximately 150+ €/t).

In general, high utilisation rates in newsprint and containerboards are enabled by cross-grade substitution, i.e. the use of old magazines in newsprint and the use of mixed wastepaper in containerboards. Overall, even in a perfect system, a virgin fibre injection of 20–25%, or even 40% (according to some experts) is needed. Ervasti (in Stawicki and Read 2010) has described this connection as a waterwheel that will stop rotating without a virgin fibre injection into the system.

In the utilisation of RCP for newsprint (Appendix IV, Trend 1, p. 3) the *main scenario* of the panellists is that the European uti-rate will stay at 90+%, perhaps slowly increasing due to increasing yield losses (see A4). This scenario is based on the cost advantage of RCP over virgin fibre. The panellists trusted that this situation will prevail, although an *alternative scenario* is that, if the RCP price keeps increasing, TMP may start to win back some of its lost market share. Arguing against this alternative scenario are expectations related to the development of energy and wood costs (the two main factors in TMP's cost) in the time frame of this study (see A1). In addition, according to the panellists, there is no indication that any quality benefits could be attributed to virgin newsprint (see A8). On the other hand, several panellists suggested that the RCP uti-rates in printing papers might turn to a decline as a result of the high RCP price (A8). Another factor supporting TMP's position is the related technical development that has already reduced, and is likely to further reduce, the specific energy consumption of TMP manufacturing (A10).

With respect to containerboards – as with newsprint – the *main scenario* of the panellists is that the European uti-rate will stay at 90+% (Trend 2), perhaps very slowly increasing due to growth in yield losses (see A14). In the majority of containerboard applications today, kraft pulp is no alternative to RCP, cost-wise. However, despite continued investments in RCP-based capacity (A13), virgin fibre cannot be eliminated from the raw material mix. This is mainly due to the specific property and quality requirements of certain kinds of packaging (A18). On a global scale, growth in the RCP uti-rate in containerboards will continue, driven by export markets, mainly China. It seems very likely that the containerboard industry's capacity to pay for RCP will ultimately be higher than that of graphic papers, newsprint included (see e.g. A15, A17). In the future, the marginal RCP quantities for papermaking might well end up being for newsprint, rather than for packaging.

5.2.2 Substitute price development

The panellists generally agreed with the following summary statements (see Appendix IV, detailed results, p. 11):

- S2.1: The substitution impact between recycled and virgin fibre is limited in the short term, but will become clear in the long term.
- S2.2: The price of pulpwood and wood in general is on a rising trend, because it is renewable. CO₂ benefits and other taxation effects will come on top of that basic fact.
- S2.3: Higher energy prices will have a double impact on the demand for RCF a) through the manufacturing cost of virgin mechanical fibre and b) through the fuel value of wood.

S2.4: In the long term, investments in southern hemisphere plantations and improved economies of scale in chemical pulping will keep pulp prices on either a declining trend, or only a moderately increasing one.

The substitution impact, i.e. some degree of *cross-price elasticity*, between RCP and wood, as well as between RCP and pulp, is accepted as existing. In the literature, the elasticity of substitution between RCP and pulp has been estimated to range between a low 0.2 in the short term and 0.8 in the long/intermediate term (Nestor 1992). Measured as cross-price elasticity, the substitution impact has been found to be fairly low, typically 0.1–0.2 (Lundmark and Söderholm 2003). The panellists were of the opinion that the substitution effect is real in the long term, but not significant in the short term.

For a deeper understanding, the price development of virgin fibre must be discussed separately for the three main segments: 1) mechanical pulp, 2) long-fibre chemical pulp, and 3) short-fibre chemical pulp. The trends affecting their price development are somewhat different. Furthermore, their technical substitution possibilities with RCF are different and therefore their cross-price elasticity with RCP is likely to vary, especially in the short term. Consequently, the arguments for their future price development, especially concerning the European paper industry, vary to a large extent.

As **mechanical pulp** manufacturing is typically integrated with paper mills, the short-term substitution of mechanical pulp with RCP is very limited, except where mills have an in-built degree of flexibility between mechanical pulp and RCP usage. Examples of such can be found at least within the cartonboard industry⁴¹ and in the newsprint industry⁴². In the long term, substitution takes place in connection with investment decisions at paper mills (capital adjustment, similar to Nestor 1992). The arguments of the panellists support the assumption that the main components in TMP manufacturing cost – electricity and pulpwood – are both on a rising trend in Europe. The only (and quite obvious) counter-argument against continued increases in demand for RCP rather than TMP is that its price may grow even faster than that of TMP.

Long-fibre chemical pulp is typically made from northern hemisphere softwood, largely in Canada, in the Nordic region, and potentially, in the future, also in Russia. In general, long-fibre pulp is an expensive raw material component and its use is typically limited to the amounts necessary for reinforcing the raw material mix. Therefore, at current price levels, its cross-price elasticity with RCP is probably very small. Lee and Ma (2001) reported the elasticity of substitution between pulp and RCP to be statistically insignificant. But if RCP prices keep rising, it might

⁴¹ Mills that have the capacity to use both mechanical pulp and RCP, depending on the sub-grade they produce. (E.g. APP Ningbo PM6)

⁴² Mills that have pulping + deinking capacity in excess of their total furnish need can optimise their usage, based on the factor costs. Such capacity is often in the form of older mechanical pulping or recycled fibre lines that stand idle for most of the time (e.g. Norske Skog Golbey).

become attractive in some applications to increase the share of reinforcement pulp, thus enabling use of even weaker components in the rest of the furnish.

Short-fibre chemical pulp is made from hardwood, increasingly from fast-growing plantations located in the southern hemisphere. In some applications, such as fine paper, there is some on-going substitution of softwood by hardwood. There is also some substitution between bleached hardwood pulp and RCP (use of high grades in manufacturing of whitetop liner and coated boards). From the technical point of view, there is probably much higher short-term cross-price elasticity between hardwood pulp and RCP, than between softwood and RCP. In the long term, too, there can be significant cross-price elasticity between hardwood pulp and RCP in the form of increasing investments in the capacity to de-ink office waste.

The panellists' view of chemical pulp price development was somewhat mixed. There were arguments in support of the forecast that pulp prices will generally increase as a consequence of the competition for all kinds of biomass, including pulpwood (A20). The fuel use of wood is especially topical in the European context. The balancing effect of a continued increase in plantation-based pulping capacity in the southern hemisphere was questioned, as suitable land for plantations is already becoming scarce. Arguments were also expressed that the price gap between long and short-fibre pulp would grow.

A factor that is further hindering substitution possibilities is the lack of pulpwood in some growth areas, such as China. This leaves producers with few options other than RCP. The track record of capacity increases in China, 1995–2007, shows a uti-rate of above 75% for all new capacity (China Paper almanac). This can be considered solid market evidence of the mentioned.

Regarding the pulpwood price in Sweden (Trend 3), the panellists expect a turn-around in the price trend. In real terms, we witnessed a declining trend in 1995–2010 (approx. 2% p.a.). Now the panellists expect moderate growth of approximately 30% in nominal terms by 2020 (approx. 2.5% p.a.), which would probably mean a slight growth in real terms as well. The arguments in support of this forecast are mainly the competing fuel use and the related subsidies (A20, A23). There are a couple of interesting perspectives on the expected development: firstly, if a functioning market for fuel wood emerged in the Nordic region, it would introduce an additional element of elasticity in pulpwood supply. In practice, the pulping quantities would be quickly curtailed by lower prices, if the alternative of selling small-diameter round wood to the fuel market existed (A24).

A second interesting perspective is the *downstream demand development* of paper products, which inevitably remains unclear. Unlike RCP, where the relative market development, i.e. RCP's market share among the raw material mix, is the decisive factor in demand (except in the very short term), the decisive factor in the case of virgin fibre is the absolute demand development. Here, significant wild cards come into play. If demand for graphic papers turned into a decline (as a consequence of e-books, increased publishing via tablets (iPad), etc.), it would quickly be reflected in pulpwood demand, thus potentially more than balancing the increasing demand in fuel use. Combined with an increase in RCP prices, this development might really cause TMP to stop losing market share. This scenario

received little support from the panellists (A30), however. On the other hand, a reduction in demand induced by high factor costs such as electricity was supported by the panel (A29). This appears to be a rather conservative statement.

The panellists also brought up the political argument of favouring the manufacturing of value-added products instead of energy. The majority of the panellists believed that this argument will have some significance in curtailing price increases in pulpwood, but some argued that energy use is nevertheless unavoidable, simply because of the high paying capacity of the energy sector (A32).

In addition to those already mentioned, there were really no arguments for a flat or decreasing price trend in pulpwood. However, there were a variety of viewpoints on how elastic the pulpwood *demand* actually is. Accepted theory holds that all intermediary products tend to have pretty inelastic demand. Some panellists were of the opinion that pulpwood price increases would quite rapidly curtail its demand. However, given the total array of responses to A28, the hypothesis remains that the own-price elasticity of pulpwood demand is low.

Thus, regarding pulpwood price development, the *main scenario* is at least some growth in real terms. The *alternative scenario* of flat or declining prices is based on weak downstream demand development combined with no significant growth in volumes for fuel use.

Regarding the development of the electricity price in the Nordic region (Trend 4), all the panellists believed in the *main scenario* of at least moderately increasing rates (nominal 4+% p.a.). The arguments for increasing prices (A35–39) were all generally accepted. The only counter-argument the panellists were able to accept was that, if the transfer capacity between the Nordic region and Central Europe were no longer expanded, and if local industrial demand clearly decreased, there might be flat price development as a consequence (A40, A42). One interesting observation concerned the further polarisation of the electricity market due to the structure of heating capacity: peak prices will increase a lot, while average summer prices might even decline (see general comments under Trend 4 and A41). This *alternative scenario* would only underline the difficulty of cost-competitive TMP manufacturing.

The majority of the panellists held the *main scenario* to be that the long-term decline in the real price of long-fibre chemical pulp (Trend 5) has ended and that a period of moderate growth is underway. However, there was considerable variation in the opinions of the panellists on the actual figures (perhaps because of the highly volatile historical price behaviour and actual abnormally high prices at the time of the study).

Two alternative scenarios, clearly worth attention, emerged as well. The *first alternative scenario* forecasts only slight growth in nominal terms and thus a continuation of the long-term decline in the real price. The main arguments for such development are the expected weak development of downstream demand (A43, A46, A49), increasing substitution by short fibre and the possible entry of new low-cost producers in Russia. It is noteworthy, though, that most of the panellists do not believe in a decline in demand (A51, A45, A46). The main arguments present-

ed are the continuing growth of Asian demand, and the demand for fibre-based packaging and tissue-paper (e.g. A45, A51).

The *second alternative scenario* can perhaps be referred to as the “bio-refinery scenario” (A43, A49). It assumes that chemical pulp mills will invest in the capacity to make significant revenue from by-products and will be able to adjust their pulp vs. by-products’ output in order to maximise the total profit. Adding value-added chemicals and biofuels to the product assortment would give pulp mills a whole new toolbox to optimise their economic performance. This might mean a big change in the own-price elasticity of chemical pulp supply. The arguments for this scenario are the numerous political bioenergy initiatives and increasing R&D investment in this area (e.g. 50% of UPM R&D funds are directed to such new products (UPM 2011). A similar phenomenon was proposed for the pulpwood market, where the emergence of a functioning fuel wood market would have a somewhat similar effect. This would create a further push at pulp mills in the direction of a “bio-refinery”.

It is also noteworthy that most of the panellists did not support the argument that an energy use of RCF-containing waste flows (or of pure RCP) that was significant enough to really impact pulp prices would emerge (A44).

The general opinion was also that investments in low-cost, short-fibre pulping capacity in the southern hemisphere will not impact long-fibre prices (A48). In other words, the price gap between long and short fibre is expected to widen (A48, A50).

Given the variation in the scenarios for the price development of long-fibre chemical pulp, it will necessarily remain a wild card in the scenarios for future RCP demand.

5.2.3 Development of RCP supply

The panellists generally agreed with the following summary statements (see Appendix IV, detailed results, p. 26):

- S3.1: Though there remains both political and demand pressure to increase the collection rates, they are estimated to be saturated soon. Some 5–10%, at maximum, is attainable on a global scale.
- S3.2: The development of collection systems towards commingled collection will increase the supply of mixed grades, thus creating further difficulties for manufacturers of graphic grades.
- S3.3: The development of collection systems will bring more flexibility for operators to optimise between the fuel and fibre markets. This is likely to create conflicts of interest between collection operators and the paper industry.

Somewhat similar statements also received support when RCP demand at paper mills was discussed (see e.g. A5 and A7). However, when speaking of absolute figures, some questions arise. First, it must be noted that the official statistics contain certain sources of error that are mainly related to the trade of goods and the packaging and paper products imported and exported with those goods (inter-

view of Ervasti I. 2010). Nevertheless, as the *main scenario*, some 5–10% growth potential is foreseen in the European collection rate (with the constant error-containing calculation method of today). Globally, the potential is estimated to be somewhat bigger, perhaps 10–20%. The driving force behind increases in collection is held to be increasing demand, which will result in a relatively high price, which, in turn, will work as a strong incentive to expand and perfect the collection systems (A52, A53). Another argument for a further increase in collection rates is the wide range of mandatory requirements set by the authorities (A52). These extend from bans of unsorted materials in landfill to packaging ordinance that sets targets for high recycling rates in packaging materials. The likely ramp-up of collection rates in the new EU member states will also add to the growth potential (A60).

Part of the *main scenario* is the increasing use of so-called commingled collection, in which several types of recyclables are collected into a shared waste bin, transported to a sorting station and sorted into commercially tradable secondary materials, such as various grades of RCP, metals, glass, plastics, etc. Commingled collection typically increases the collection rate and delivers especially mixed grades at reasonable cost, but rather poor purity. In the author's S/D model, the increasing use of commingled collection has the capacity to move the curve S_{RCP} to the right. The cost structure of commingled collection is sorting-biased, compared to other collection systems. In other words, the cost difference between delivering a quantity to the fuel market vs. to the paper market is higher than in other systems (A54, A55).

Given the fact that the growth potential of collection in Europe is almost solely within household collection (A61) and mainly in rural areas, we can conclude that the shape of the curve S_{RCP} will become fairly steep by increasing the collection rate; i.e. the own-price elasticity of RCP supply will shrink.

The *alternative scenario* is that strong growth in waste-to-energy will consume a major chunk of the growth potential in collection. Based on today's figures and estimates, the European collection rate is already about 80% of the Q_{MAX} . The waste volumes in advanced W-t-E (mainly SRF) were estimated at about 12 million t/a in 2006 (Straetmans 2010). According to Ristola (2004a), Hietanen (2009) and Beckmann et al. (2007), the discarded paper content in these flows could be about 3–5 Mt. This RCF volume already represents 20–25% of the remaining growth potential between the volume collected as per today and the Q_{MAX} . The panellists unanimously agreed that energy use will consume at least some part of the growth potential in the collection rate, but how much, and whether it would cause some people to actually reduce recycling, remains to be seen (A63).

5.2.4 Market development related to the energy utilisation of RCF

The final section, market development related to the energy utilisation of RCF, can be considered the most ambiguous part of this study. This market is still in its infancy, and there is simply not much numerical data or trends available that could

have been commented on or argued over by the panellists. However, the two selected factors, CO₂ price development and the consumer price of transport fuels, are clearly linked with the overall demand development of the renewable fuels market and therefore with the potentially emerging fuel market for discarded-paper-containing waste flows as well. One clearly missing component is the price and volume development of the solid recovered fuel, SRF, (or refuse-derived fuel, RDF) market. Unfortunately, no proper data on this market was available for inclusion in this research. The previous section 5.2.3 ended up by quoting some estimated figures that the author received from market insiders who participated on the panel.

The panellists, without exception, agreed with the following summary statements (see Appendix IV, detailed results, p. 31):

- S4.1: Based on current and forecast price differences between RCP and different bio-fuels, there is very small risk that standard RCP grades will be used for fuel in West Europe.
- S4.2: There is a clear trend to build waste-to-energy power plants at paper mill sites and for certain other industrial uses. As increasing use of waste-to-energy will eat up some of the future growth potential from the RCP supply, this trend will have at least an indirect impact on prices and quantities of RCP.
- S4.3: The strong political support for renewable energy and biomass in particular will cause at least a small disturbance on the RCP market (e.g. in the form of CO₂ credit benefits).
- S4.4: The technical development of waste-to-energy (and biomass-based energy in general) remains a wild card in future speculations. There are arguments and opinions for and against it having a big impact.

Based on these and specific answers to the arguments presented, the *main scenario* regarding the fuel use of RCF can be formulated. Even considering the ongoing trend to build efficient waste-to-energy power plants at paper mills and other industrial sites, there is very small risk of standard RCP grades being used for fuel in West Europe. Even if the CO₂ price reached 25–30 €/t (which the panellists appear to expect by 2020⁴³), the current high RCP prices would still be able to steer towards the collection and trade of RCP as a raw material. However, it was unanimously agreed that the mentioned on-going investments will definitely erode some of the future growth potential of the RCP supply and thus indirectly affect the traded quantities and prices of RCP.

The *alternative scenario* is formed from the eventual realisation of a number of concepts that today must be considered technical wild cards. These include e.g. ethanol conversion from the cellulose content of wastes. It has been calculated

⁴³ In fact, the panellists gave hardly any support to arguments in support of a future low price level for CO₂ credits.

that a feed tariff of about 2 €/l would provide paying capacity equal to 200 €/t for RCP. Here, the panellists expect the pump price of diesel and gasoline to hit around 1.9 €/l by 2020. Therefore, if it is found to be technically sound and politically acceptable, the conversion of liquid fuels from the cellulose content of wastes could well become reality.

Regarding the future of CO₂ cap&trade systems, most of the panellists believed that at least some type of mechanism would survive in Europe. Whether the US and the rest of the world will join is a question for speculation, but it would most likely have a balancing effect on prices, as the most effective greenhouse gas mitigation actions would then be realised. Some questions arose as to whether political pressure to cancel or dilute the present system would emerge as a result of “carbon escape”; i.e. continuing the transfer of industrial production to low-cost countries without cap&trade burdens (A68).

Regarding the future development of transportation fuel prices, the panellists were mostly in agreement that the historical growth trend will continue, at rather a constant pace (1.9 €/l by 2020). Given the presumption that the oil peak is either at hand or has already been passed (A69), and that demand will still increase (A70, A71) and that high paying capacity will continue in the west (A72), one could even imagine a step change in this development. The generally accepted arguments for only moderate growth were the reduction of specific fuel consumption (A79) and the emergence of alternative fuels and electric cars (A81). The remaining arguments and responses to them can be considered more or less ambiguous.

5.3 Key results from the perspective of scientific foresight

Tables 5.2–5.5 categorise the key results of the Delphi study, which, substance-wise, were already discussed in the previous sections. The outputs are again grouped under the four main headings – RCP demand development, substitute price development, RCP supply development and market development – related to energy utilisation of RCF. Under each heading, the forecasts that are together considered to form the main scenario for future development are first listed. Next, the forecasts that indicate alternative scenarios for future development are listed. All forecasts are classified either as strong prospective trends, (normal) trends or weak signals. The following rules are used in the classification:

- To qualify as a strong prospective trend, a forecast must have an evidence base consisting of the facts of already realised development, and of the expert opinion supporting its future development. C.f. Toivonen 2004, p. 132.
- If a forecast is supported by facts or trends from past development, but expert opinion does not support its future development, the forecast is here classified as a *trend*.
- If a forecast is not supported by facts or trends from past development, but expert opinion supports it, it is here classified as a *weak signal*. To qualify

for the list, the product of probabilities and the potential impact of a given weak signal has to be significant.

When the outputs are viewed against the framework of scientific foresight presented in Chapter 2, the following main observations can be made:

- As expected, the main scenarios described under each heading mostly consist of *strong prospective trends* – the only exceptions are a) pulpwood price development and b) the growing difference in the marginal costs of producing flows to the fibre vs. fuel market by increasing the collection rate.
- The forecast of continuing growth in RCP utilisation is also classified as *transient invariance* to emphasise its stable nature.
- The growth in the pulpwood price is classified as a *weak signal*, as it has not yet been recognised in the available statistics of the Swedish pulpwood price. However, there is evidence of the mentioned development from other markets and therefore it is considered part of the main scenario.
- The forecast of a growing difference in the marginal costs of producing flows to fibre vs. fuel market by increasing the collection rate is supported by expert opinion, but the numeric facts are simply not available. Thus it is classified as a *weak signal*, but still considered part of the main scenario.
- The forecasts that were at least partly included in the pre-identified trends in this research have been marked in Tables 5.2–5.5 with an asterisk (*). It is interesting to note that fewer than half of the forecasts were pre-identified.
- One alternative scenario regarding the development of the pulp price, namely the “bio-refinery” scenario is especially interesting. The whole notion of a bio-refinery has already turned *institutional*⁴⁴, at least in Finland, but the finding of its likely impacts on the market for papermaking raw materials is very interesting. If broadly realised, it might have a big impact on the *own-price elasticity* of pulp supply, surely radiating to the price behaviour of other papermaking raw materials as well. It is quite another question whether its commercial realisation is just an *institutional belief*.
- All the main factors (A to F) affecting the composite RCF market model as outlined in Chapter 4 are covered, although the coverage of factors D, E and F is quite thin, especially of the D and F supply schedules related to the production of solid recovered fuels. This is mainly due to the limited availability of any numerical data in this young market area.

⁴⁴ Future studies are often plagued by *institutional foresight* (Loveridge 2000, in Toivonen 2004, p. 123), i.e. instead of identifying true weak signals they are just capable of confirming anticipations of the future that have already been expressed by some institutions or other authorities.

5. Delphi study on the supply-demand behaviour of recycled fibre

Table 5.2. Key results of the Delphi study related to RCP demand development.

A. RCP demand		
Main scenario		Classification
RCP Utilisation	Growth will continue (*)	Strong prospective trend (Transient invariance)
Uti-rate in newsprint in Europe	Stays at 90+ %.	Strong prospective trend
Uti-rate in containerboards in Europe	Stays at 90+ %.	Strong prospective trend
Alternative scenarios		Classification
Uti-rate in newsprint in Europe	Slight decline in favor of TMP due cost development.	Weak signal

One obvious criterion for a successful Delphi study is that it should be able to generate a degree of joint opinion or understanding among panellists. The panel may not need to agree on all aspects but the Delphi process should be able to effectively communicate the arguments of the panellists supporting alternative views of development and identify the reasons for them. In fact, there is also a lot of value in items where the panellists are in disagreement, if it occurs after a good amount of argumentation for and against. The panel at hand reached a clear consensus concerning RCP demand development. The only noteworthy difference in opinions remained on the development of the RCP uti-rate in newsprint in Europe. The clear majority of the panellists supported the arguments for the uti-rate staying above 90+%. However, the arguments related to ONP/OMG demand gradually developing elasticity at its current high price levels received support as well. Therefore a decline in the uti-rate in newsprint must be considered as a possible alternative scenario.

Table 5.3. Key results of the Delphi study related to substitute price development.

B. Substitute price development		
Main scenario		Classification
Pulpwood price in Sweden	Some growth in real terms, mainly due fuel use. (*	Weak signal
Price of electricity in Nordic	At least moderately increasing. Especially increase in peak prices.	Strong prospective trend
Long fibre chemical pulp price	Moderate growth of trend price.	Strong prospective trend
Alternative scenarios		Classification
Pulpwood price in Sweden	Flat or declining e.g. due weak downstream demand and no significant fuel use.	Trend
Chemical pulp price	Declining real prices due weak downstream demand development.	Trend
Chemical pulp price	Strongly increasing prices due competition for biomass. (*	Weak signal
Chemical pulp price	Increase in own-price elasticity of chemical pulp supply due to the "Biorefinery scenario".	Weak signal

In substitute price development the Delphi panel ended up with a much wider diversity of opinion than in any other area. A consensus was reached concerning the development of the electricity price, but a large divergence of opinion prevailed regarding pulpwood and chemical pulp price development. In case of the pulpwood price, 82% of the panellists still supported the above-named main scenario. In the case of long-fibre chemical pulp price development, the corresponding figure was 70%. However, the different opinions were defended by highly relevant arguments and therefore, concerning both the pulpwood and chemical pulp price, the alternative scenarios must be considered possible. The "bio-refinery scenario" with potentially big effects on the price elasticity of the pulp supply received some criticism after the final report was distributed. It is believed to be somewhat relevant in the case of value-added products processed from the cellulose fraction, but not really so in the case of producing e.g. biodiesel from the energy fraction, simply because, in that case, there is technically not that much flexibility in the pulp yield.

5. Delphi study on the supply-demand behaviour of recycled fibre

Table 5.4. Key results of the Delphi study related to RCP supply.

C. RCP supply		
Main scenario		Classification
RCP collection rate	Continues to grow but will saturate between 75-80%.	Strong prospective trend
Collection systems	Increasing use of commingled collection => increasing share of MWP, increasing sorting costs. (*	Strong prospective trend
Alternative scenarios		Classification
RCP collection rate	Strong growth of W-t-E will cause RCP collection to saturate soon.	Weak signal

Concerning the development of RCP supply, a joint consensus was again reached. A limited growth potential in the collection rates exists, which means that saturation of the collection rate is expected in Europe by 2020, at the level of 75–80%. Regarding most aspects, a consensus was also reached in factors related to the energy utilisation of RCF. As discussed earlier, this whole topic area was unfortunately supported by the fewest numerical facts – simply due to the market being in its early phases and to the consequent lack of data. Most panellists also agreed that eventual large-scale implementation of EtOH from waste or other similar advanced W-t-E concepts must be considered a wild card in making predictions of the market development.

Table 5.5. Key results of the Delphi study related to the energy utilisation of RCF.

D, E, F. Energy utilisation of RCF		
Main scenario		Classification
General	No erosion of RCP to fuel use will take place.	Strong prospective trend
Supply schedule of RCP as fuel (D)	Widening of the gap in marginal cost is expected as Q nears Q_{MAX} .	Weak signal
SRF demand (E)	Investments in advanced W-t-E will continue. (* Prices gradually turning positive.	Strong prospective trend
SRF supply (F)	Lack of waste is emerging.	Strong prospective trend
European price of CO ₂ -credits	Cap&trade mechanism continues in Europe. Price around 25-30€/t by 2020.	Strong prospective trend
Transportation fuel prices in Germany	Historical growth trend will continue.	Strong prospective trend
Alternative scenarios		Classification
General	Large-scale realisation of EtOH from waste or other similar concepts might drive prices of discarded paper containing feedstocks up (* and could even cause bleed of RCP to energy utilisation	Weak signal
European price of CO ₂ -credits	Reduction of regional targets under pressures of globalisation.	Weak signal

The objective of this chapter was to define answers to the following research questions:

- Q5: What phenomena are likely to affect the RCF market in the future?
- Q6: Are any such market phenomena likely in future that might suggest increasing interplay between the markets of discarded-paper-containing flows as raw material and as fuel?

The formal answer to Q5 constitutes all the main scenarios and alternative scenarios listed in Tables 5.2.–5.5. All of these will be utilised in testing the proposed S/D model in the next Chapter.

The answer to Q6 is somewhat mixed, but initially rather yes than no, considering the following arguments:

- Yes, in the sense that the panellists agreed to the hypothesis that continuing investments in advanced W-t-E will eat up some of the growth potential in RCP collection.

5. Delphi study on the supply-demand behaviour of recycled fibre

- Perhaps, in the sense that large-scale utilisation of EtOH from waste and other advanced W-t-E concepts might cause erosion of flows from the RCP market to the fuel market.
- Yes, in the sense that the gap between S_{RCP} and S_{RCPF} is expected to grow by increasing the collection rate, i.e. it is expected to grow over time.
- No, in the sense that the panellists were of the opinion that there is very small risk that standard RCP grades would be used for fuel in Western Europe. This is, after all, the most direct and obvious aspect of the suspected interplay between these markets.

More insight on Q6 will be sought by testing of the proposed market model.

6. Testing the proposed S/D model with Delphi outputs

The objective of this chapter is to define answers to the following research questions:

Q7: What are the main and alternative scenarios for the future development of the RCF market?

Q8: Can the scenarios and the conditions under which they will be realised be meaningfully quantified by using the constructed model?

A further objective is to complete the answers to Q4 and Q6 that were previously left partly open.

This chapter answers these research questions by combining the proposed composite model of the RCF market with the foresight gained as outputs from the Delphi study. In practice this is achieved by quantifying a *main scenario* for the development of the composite RCF market, and by presenting a few *alternative scenarios*, the effects of which are discussed in comparison with the main scenario. In the framework of *constructive research* this exercise serves as a test of the *practical functioning* of the proposed construct, i.e. the composite model of the RCF market.

The aim of the testing is not to create accurate numerical predictions of the market development, but rather to gain indicative information: what can be concluded on the market conditions under which the specific market phenomena will take place.

6.1 Present RCP market in Europe

In 2009 the collection rate of RCP in Europe⁴⁵ reached 72.2%. This high figure was a result of a quick dip in paper consumption during the global recession and a lag of 3–6 months before the reduced consumption fully showed up in the collected

⁴⁵ As before, *Europe* again refers here to the so-called CEPI Europe. For definitions see Chapter 1.5.

volumes. The European Recovered Paper Council estimates that in 2010 the collection rate is likely to be $66\% \pm 1.5\%$ (European Recovered Paper Council 2010). This figure is used as the assumption of the present collection rate. For paper consumption this study uses a figure of 95 Mt, which consists of about 90 Mt of reported consumption and about 5 Mt (5%) of unreported net consumption, mainly consisting of packaging materials, manuals, guarantee slips etc. that enter the RCF market via imports of products.^{46, 47} After considering about 15% of the paper consumption as non-recoverable⁴⁸ (disposed of in the sewer system, burned in domestic fireplaces etc.) these figures yield a Q_{MAX} of 81.5 Mt and a Q_{RCP} of 59.4 Mt or 72.9% of Q_{MAX} . The Q_{RCP} can be further split by the main grades of RCP, each commanding different prices.

Figure 6.1 illustrates the structure of the RCP market *cascaded* by the four main grades. The marginal quantity of RCP is represented by the MWP traded at around 73% of Q_{MAX} at a price of approximately 100 €/t⁴⁹. The three other main grades, namely high grades (HG), old newsprint and magazines (ONP/OMG) and old corrugated containers (OCC) are traded at somewhat higher prices and together they form a 4-component cascade model of the RCP market where the HG market covers quantities 0–7% of Q_{MAX} , ONP/OMG 7–26%, OCC 26–57% and MWP 57–73% of Q_{MAX} . The plotted shapes of the supply and demand schedules for each of these grades are at this point approximations only. These markets are also not fully independent of each other, but a certain amount of substitution exists in many end uses and suppliers also have some flexibility to balance between different outputs from their collection and sorting systems.

⁴⁶ There is no public, scrutinized research available on true unreported quantity. 5 Mt can be considered a reasonable estimate (interview of Ervasti I. 2010).

⁴⁷ Cao (2006) of China's National Pulp and Paper Research Institute has estimated that over 20 Mt of packaging is exported with goods from China. According to WTO (2011) about 20% of goods are exported to EU from China. If we take into account the growth in Chinese exports since 2006 the estimated 5 Mt level is realistic.

⁴⁸ Typical figure used is 19–20% (Interview of Ervasti I. 2010). A lower figure is used here to reflect the share of contaminated papers still available for the fuel market.

⁴⁹ This represents the approximate MWP price level at the time of reporting this study.

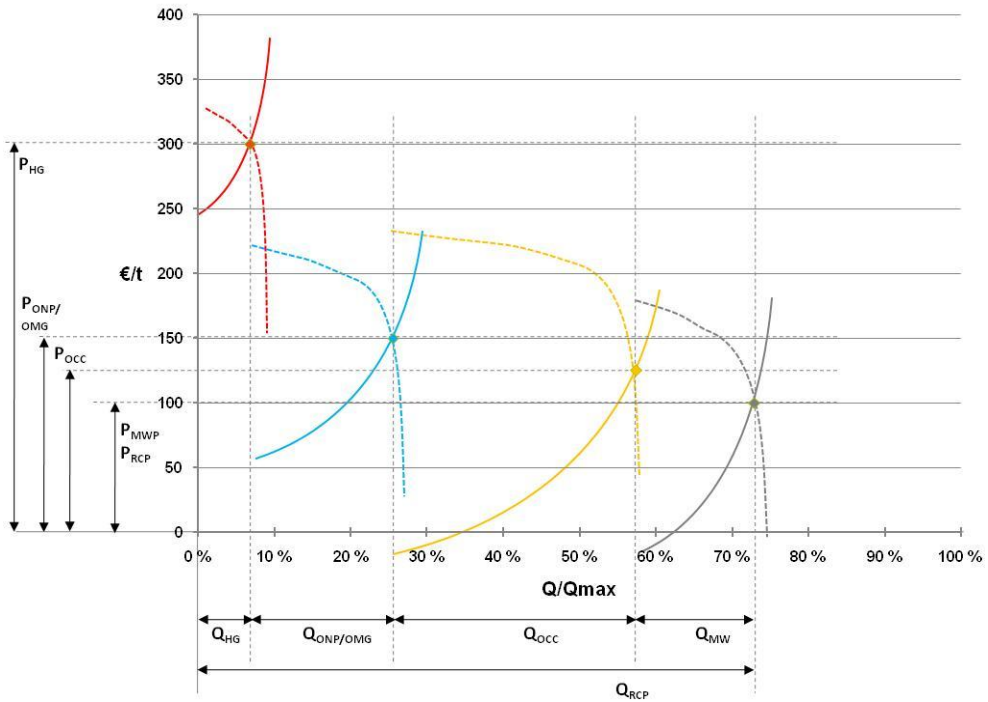

Figure 6.1. The RCP market in the CEPI area, cascaded by main grades. (Source of quantities: CEPI 2010, interview of Ervasti I. 2010. Source of prices: market information.)

Figure 6.1 includes the quantities sold on both the domestic and export markets. In 2009 net exports from Europe represented about 20% of the collection (CEPI, 2010). Figure 6.2 presents a simplified model of the interaction between the European and the global RCP market. Globally the marginal quantity Q is traded at P , whereas Q_{EX} is the net exports out of Europe and it equals the net imports by the rest of the world (ROW). As Europe is a net exporting region, the European demand (D_E) finds itself below the demand of the rest of the world (D_{ROW}).

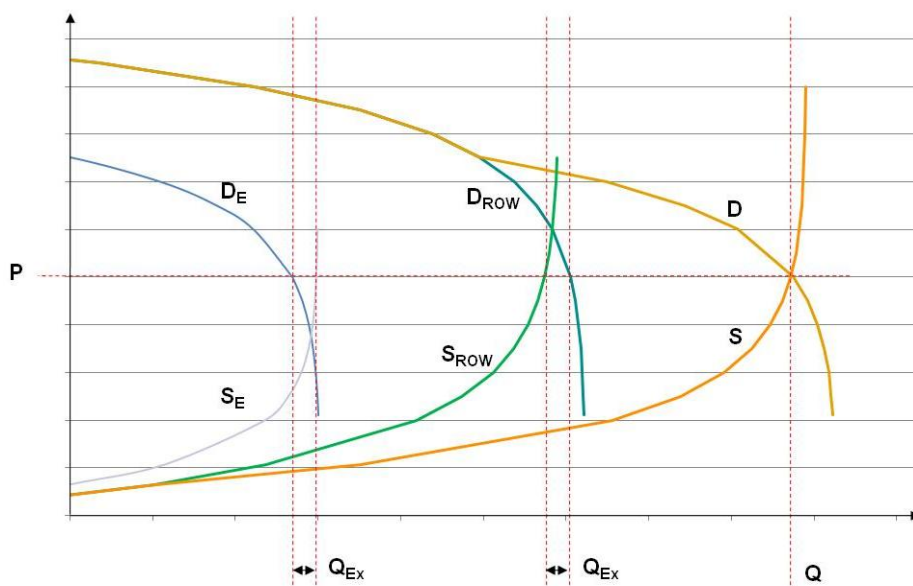

Figure 6.2. European vs. the global RCP market D_E / S_E = European demand and supply, D_{ROW} / S_{ROW} = demand and supply in the rest of the world, D / S = composite global demand and supply.

A phenomenon with a large impact on the global RCP market is the Euro / USD exchange rate. Its impact can be explained by a three-component composite market model consisting of Europe (E), North America (NA) and ROW (see Figure 6.3). The dotted lines in Figure 6.3 display the result of a 25% weakening in NA currency (USD) against the European and ROW currencies; i.e. the European and ROW currencies remain stable against each other and the change in exchange rate does not impact D_{ROW} or D_E even indirectly, via downstream demands in their value chains⁵⁰. The result of the described change in exchange rates is a slight decrease in P (measured in Euros), an increase in North American net exports, a decrease in European net exports and an increase in ROW net imports.

⁵⁰ This is a simplification, only to illustrate the phenomenon. In real life, the most important currency in the ROW basket in terms of global RCP trade is obviously Chinese RMB that maintains a connection with USD by political decision (against macroeconomic principles). Therefore, the example of the ROW basket and the Euro remaining stable to each other, while the USD devaluates, is only hypothetical.

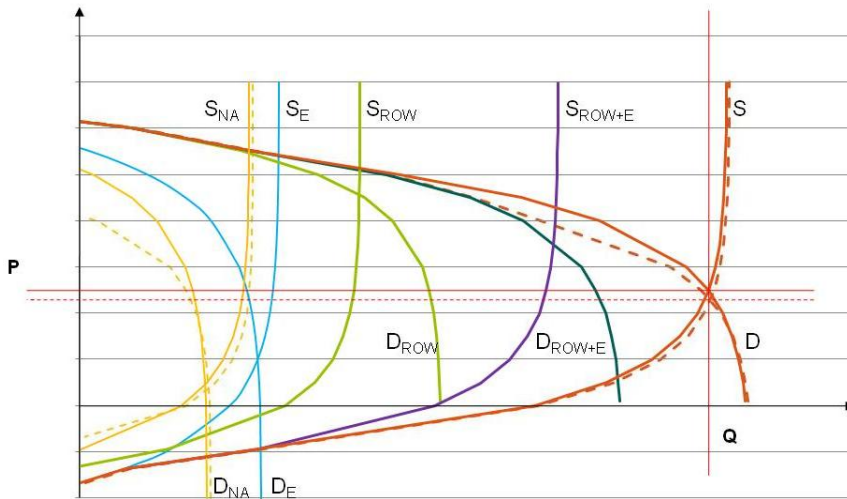

Figure 6.3. Effect of exchange rate change. D_E / S_E = European demand and supply, D_{NA} / S_{NA} = North American demand and supply, D_{ROW} / S_{ROW} = demand and supply in the rest of the world, D_{ROW+E} / S_{ROW+E} = composite demand and supply of the ROW + Europe, D / S = composite global demand and supply.

6.2 The composite RCF market in Europe

When making an attempt to quantify the interplay between the RCP and SRF markets it is enough, for the sake of simplicity, to look just at the marginal RCP quantities. These can be considered to be the MWP quantities sold at prices that are determined on the global market.

The approach chosen to model the demand for MWP, as well as the demand for SRF, is based on the reasoning that, as factors of production, the own-price elasticity of their demand is quite low at typical price levels, but will grow by price exponentially, *ceteris paribus*. This means, on the one hand, that at a certain price level their demand will shrink to zero. On the other hand, their demand should never exceed a threshold value that is linked to the nominal capacity of the installations capable of using them as a raw material; i.e. no capital adjustment is allowed. The principles of this approach were already presented in section 4.4 and were developed in the course of the research in interaction and in iterative fashion with the Delphi panel (see summary of first round findings, Appendix III).

Mathematically expressed, the demand can be expected to follow the simple formulas (1 & 2) below:

$$Q(P) = k - a \text{EXP}(bP), \text{ where} \quad (1)$$

k is the constant reflecting the capacity limit of the system, a and b are constants contributing to the scale and rate of change in elasticity by P

6. Testing the proposed S/D model with Delphi outputs

because k represents the maximum value for Q , $a > 0$

In the case of demand, Q decreases by P which means that Q' is always negative, thus also rendering the constant b positive, and therefore

$$dQ / dP = - a b \text{EXP} (b P); \quad a > 0, b > 0 \quad (2)$$

Thus if $P \rightarrow -\infty$ then $Q' \rightarrow 0$, and $Q \rightarrow k$.

The constants a , b and k can be extrapolated by using the information on short-term elasticities of demand (ϵ) for two price levels, P_1 and P_2 , and an estimate of the present level of price and quantity, P_0 and Q_0 :

The generic formula of own-price elasticity:

$$\epsilon = Q'(P) P / Q(P) \quad [\text{or } dQ/Q \div dP/P] \quad (3)$$

The formula used for extrapolating constant b :

$$\ln (\epsilon_1 / \epsilon_2) = b (P_1 - P_2) + \ln ((\epsilon_1 - P_1 b) / (\epsilon_2 - P_2 b)) \quad (4)$$

The formula used for extrapolating constant a :

$$\epsilon_1 Q_0 + \epsilon_1 a \text{EXP} (b P_0) - \epsilon_1 a \text{EXP} (b P_1) = - P_1 a b \text{EXP} (b P_1) \quad (5)$$

Then k can be solved by e.g. using formula (1) and the present price and quantity information, P_0 and Q_0 .

For MWP, we know that the quantity collected and sold from Europe is about 12 Mtpa, of which about 20% is exported, and the average price is about 100 €/t. Thus European demand for MWP, $Q (100 \text{ €/t}) = 10 \text{ Mt/a}$ ($0.8 \times 12 \text{ Mt/a}$) or 12% of Q_{MAX} . We also know from the literature that short-term demand elasticities tend to be in the range of $-0.00 \dots -0.10$ (Anderson and Spiegelman 1977, Edgren and Moreland 1989, Nestor 1992). However, by market observations we know that the demand starts to bend (develop significant elasticity) after the 150 €/t price level. This is also in line with some of the more recently reported and higher own price elasticities such as -0.85 by Samakovlis (2001, in Lundmark and Söderholm 2003). Figure 6.4 presents a result of extrapolation using formulas (1–5) and this information. The own-price elasticity of the proposed formula is -0.05 at 50 €/t and -0.85 at 150 €/t. The demand for MWP would shrink to nil at P of 240 €/t and it would never exceed 14% of Q_{MAX} , no matter how low the prices were⁵¹.

⁵¹ Naturally, the market for MWP is not disconnected from the markets for other RCP grades – quite the contrary, as there exists a fair amount of substitution between the grades. If the supply of MWP changed radically overnight, causing changes in the market price under the MWP demand schedule, there would be changes in the markets for other RCP grades as well. This dynamism is put aside here for the moment, but referred to when interpreting the results from the model and the Delphi study.

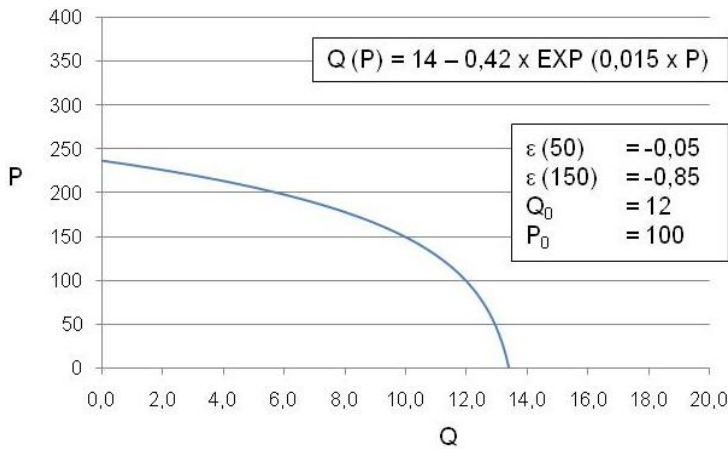

Figure 6.4. Estimated demand schedule for MWP (Q expressed as %-units of Q_{MAX}).

The quantification represented by the formula of Figure 6.4 is only an estimate of the demand schedule, but it appears to share features observed in the present marketplace and is in fairly good agreement with previous econometric analyses of the waste paper market.

Similarly to MWP, Figure 6.5 presents the extrapolation result for SRF demand. It assumes that the present SRF market volume is roughly 9 Mt (about 45 TWh/a) and that its discarded paper content is approximately a third (3 Mt or 4% of Q_{MAX}). For the current price of SRF it assumes 5 €/MWh or about 25 €/t⁵². Similarly to RCP, SRF as a factor of production tends to have low own-price elasticity of demand. Both are also raw materials for highly capital-intensive operations but, on the other hand, SRF boilers often have several potential substitute fuels creating some elasticity in the demand. At a typical price level of about 10–25 €/t, the demand schedule of Figure 6.5 shows elasticity between -0.06...-0.3. The demand shrinks to nil when prices are near the current fuel wood price less the diluted CO₂ benefit of SRF⁵³, i.e. at about 60 €/t. On the other hand, SRF demand maintains some elasticity with negative prices as multi-fuel boilers increasingly become interested in utilising it (Straetman 2010, interviews of Hietanen L. 2011 and Sipilä E. 2011).

⁵² There is no such widely established market for SRF as there is for the RCP grades. SRF is often delivered on the basis of long contracts, and in general there are larger local variations in prices.

⁵³ Only part of SRF is considered to be CO₂ neutral; i.e. using SRF calls for about 60% of CO₂ credits in comparison to coal, whereas wood is completely CO₂ neutral and consumes no CO₂ credits.

6. Testing the proposed S/D model with Delphi outputs

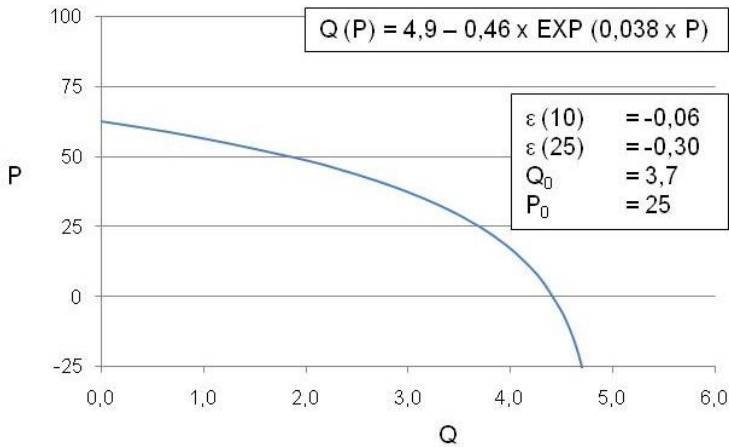

Figure 6.5. Estimated demand schedule for SRF (Q expressed as %-units of Q_{MAX}).

The supply of both MWP and SRF is also assumed to follow an exponential formula since the quantity offered to the market is also ultimately limited by a certain type of nominal capacity – in this case of existing collection systems and processing plants. Exactly the same formulas as for demand (1–5) apply:

$$Q(P) = k - a \text{EXP}(bP), \text{ where} \quad (6)$$

k is the constant reflecting the capacity limit of the system, a and b are constants contributing to the scale and rate of the change in elasticity by P

because k represents the maximum value for Q, $a > 0$

In the case of supply, Q increases by P, which means that Q' is always positive, thus rendering the constant b negative.

$$dQ / dP = - a b \text{EXP}(bP); a > 0, b < 0; \quad (7)$$

Thus if $P \rightarrow \infty$ then $Q' \rightarrow 0$, and $Q \rightarrow k$.

The constants a, b and k can be extrapolated by using the information on the short-term elasticities of supply (ϵ) for two price levels, P_1 and P_2 , and an estimate of the present level of price and quantity, P_0 and Q_0 :

The generic formula of own-price elasticity:

$$\epsilon = Q'(P) P / Q(P) \quad [\text{or } dQ/Q \div dP/P] \quad (8)$$

The formula used for extrapolating constant b:

$$\ln(\epsilon_1 / \epsilon_2) = b(P_1 - P_2) + \ln((\epsilon_1 - P_1 b) / (\epsilon_2 - P_2 b)) \quad (9)$$

The formula used for extrapolating constant a:

$$\varepsilon_1 Q_0 + \varepsilon_1 a \text{EXP} (b P_0) - \varepsilon_1 a \text{EXP} (b P_1) = - P_1 a b \text{EXP} (b P_1) \quad (10)$$

Then k can be solved by using e.g. formula (6) and present price and quantity information, P_0 and Q_0 .

In the case of MWP supply, we hold to the previous assumption of Q (100 €/t = 12 Mt/a or 15% of Q_{MAX} (of which about 2 Mt/a is sold on the export market). We also know from the literature that short-term supply elasticities used to be in the range of 0.1–0.2 (Gill and Lahiri 1981, Edgren and Moreland 1989). However, it is easy to imagine that the elasticity quickly approaches zero by increase of price, as increase of quantity becomes increasingly expensive to reach (again, not allowing capital adjustment, i.e. investments in the collecting and sorting systems). On the other hand, as the supply schedule by definition is the marginal cost curve of the suppliers, it should turn elastic by the decrease of price. We must also bear in mind that past price behaviour has shown that, during sudden drops in demand, the prices dip below or close to zero from time to time⁵⁴. Figure 6.6 presents a result of extrapolation using formulas (6–10) and this information. The own-price elasticity of the proposed formula is 0.2 at 50 €/t and 0.1 at 100 €/t.

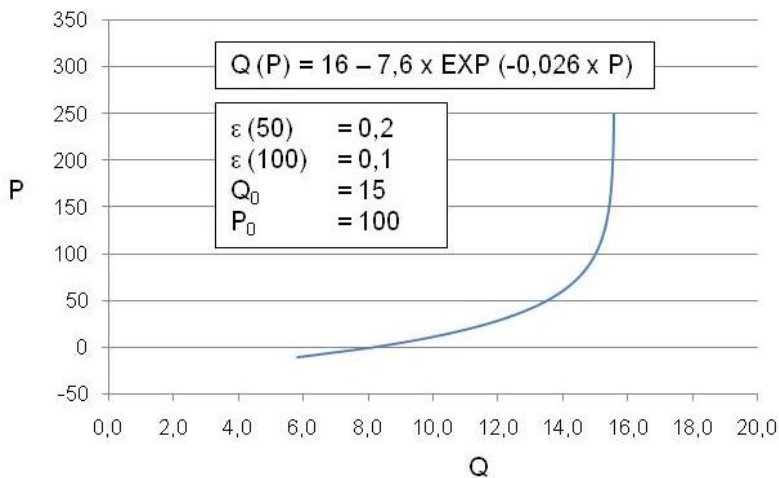

Figure 6.6. Estimated supply schedule for MWP (Q expressed as %-units of Q_{MAX}).

⁵⁴ From the RCP collectors or traders point-of-view the marginal cost curve is much flatter, but this model takes a more systemic view by considering the negative stumpage cost for a large fraction of input streams. E.g. if the demand for RCP suddenly halved, all discarded paper entering the municipal collection would still have to be disposed of. This de facto means a negative stumpage cost, even if it is not visible for the actual RCP operators. C.f. section 4.4.1 and Figure 4.9.

6. Testing the proposed S/D model with Delphi outputs

Similarly to MWP, Figure 6.7 presents the extrapolation result for SRF supply. At the current price level of about 10–25 €/t, the supply schedule of Figure 6.7 shows a very low elasticity of 0.05–0.06. According to the observations of market insiders (interview of Hietanen L. 2011) the supplying industry produces all the flows it can source at the current price level and the volumes would hardly be impacted if the price decreased towards zero. In other words, the supply is highly inelastic in the current market conditions. The plants producing the SRF type of fuel typically have some flexibility in capacity to meet changes in demand by e.g. adding shifts, but the availability of suitable waste flows limits the supply. At the low end of prices, the supply gradually shrinks to nil when prices approach -50 €/t or -10 €/MWh (interviews of Hietanen L. 2011 and Sipilä E. 2011).

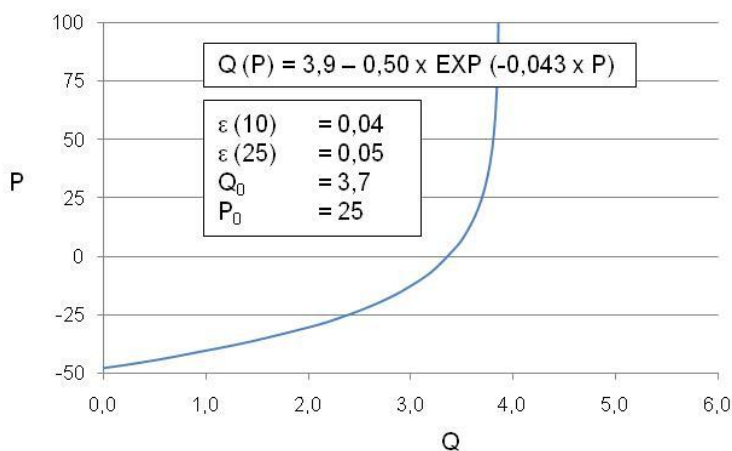

Figure 6.7. Estimated supply schedule for SRF (Q expressed as %-units of Q_{MAX}).

Next we shall look at the supply and demand schedules for MWP and SRF when displayed together in the same diagram (see Figure 6.8). When the MWP market is plotted on a chart showing the whole potential of discarded paper for utilisation on the x-axis, it lands between 57–72% of Q_{MAX} and commands a price of 100 €/t. Of the remaining 28%, the SRF market occupies about 4% and trades at around 25 €/t, leaving 24% in disposal⁵⁵. The disposal cost in Europe is typically around -80...-100 €/t. A part of the remaining potential in disposal is so contaminated that it is not attainable for the RCP market, while it could be used on the SRF market.

⁵⁵ This figure includes minor amounts of discarded paper utilised in molded products and insulation materials as, case by case, they are not always included in the RCP statistics (Interview of Ervasti I. 2010).

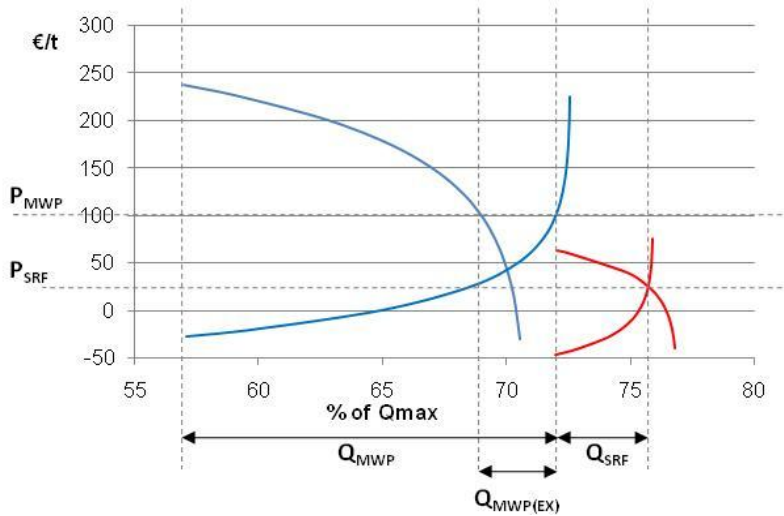

Figure 6.8. Estimated supply and demand schedules for MWP and SRF (Q expressed as %-units of QMAX; Quantities 0–57% of QMAX are covered by other RCP grades).

In today's market situation illustrated by Figure 6.8 there remains a clear price gap between the MWP and SRF price and there appears to be hardly any risk for interaction between these markets. However, a central element in the proposed market model, the shadow supply schedule of RCP as fuel, is still missing from the picture. Now we enter an area where we seriously face handicaps in the available information – there is simply no published information available and one must rely on pure deduction. As discussed in section 4.4.2 and illustrated by Figure 4.12, the supply schedule by definition is the marginal cost curve of the suppliers. Producing fuel out of the flows that can potentially be sorted, baled and shipped to the RCP market reduces the need for sorting, but adds the requirement of shredding. Potentially it can simplify the collection, but there is little impact in the short run. The supply schedule in Figure 6.9 assumes that, for more than a half of the MWP quantities, the shredding would be more expensive than the sorting required in the RCP market. On the other hand, the cost of sorting logically increases by Q and therefore also increases the gap between S_{RCP} and S_{RCPF} .

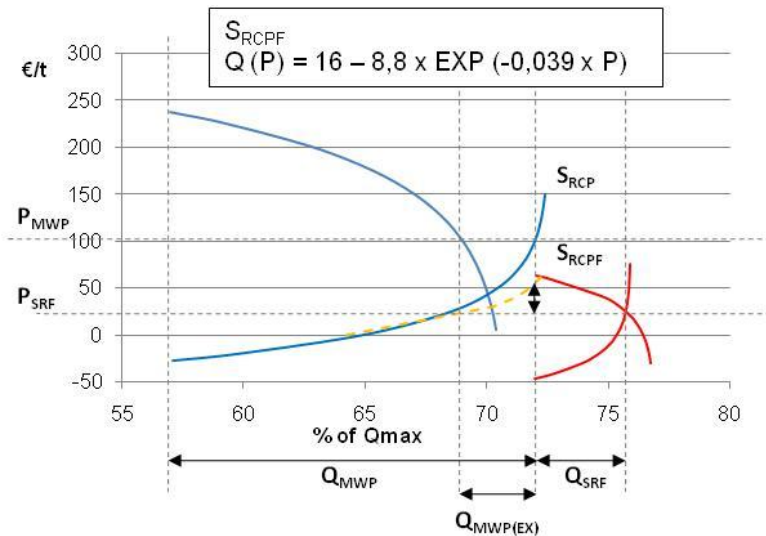

Figure 6.9. Estimated shadow supply schedule of MWP as fuel (S_{RCPF}) in comparison to the MWP and SRF markets.

The estimation of the market balance depicted in Figure 6.9 leaves a clear gap between the SRF price and the shadow supply cost of the marginal quantity Q_{MWP} to the fuel market. This has to be the case in the present situation as no noteworthy bleed is known to exist between these two markets (c.f. Chapter 5, results of the Delphi panel). It is interesting to note that the present assumptions suggest that, without the export market of MWP, there would remain hardly any gap between the fibre and fuel market. Furthermore, as confirmed by the Delphi panel, this state of affairs does not mean that there would be no interaction between these two markets. If the SRF market continues to develop, it still threatens to consume a portion of the growth potential in RCP collection.

6.3 Scenarios for the European RCF market

What can be concluded on the expected market development based on the market model and the foresight gained in the Delphi study? First we need to draft some quantifications based on the Delphi findings.

6.3.1 Main scenario by the year 2020

The following seven assumptions are used based on the expert opinion gained in the Delphi study. The quantifications are by the author. No depreciation effect to 2020 is considered in the model; i.e. all prices and changes should be considered to happen in real terms.

1. Delphi: "The collection rate of RCP saturates at about 75–80%."
 - Because the model uses 66% as the present collection rate this would represent an increase of 9–14%-units. As the share of MWP is presently about 20% of total RCP, we will assume a 2–3%-unit increase in the amount of MWP measured as % of Q_{MAX} .
 - S_{RCP} presently covers 15%-units, i.e. 57–72% of Q_{MAX} , with capacity limit of supply at 16% (constant k). For S_{RCP} this value is now assumed to increase by 3%-units due to improvements in collection by 2020. This means a horizontal shift of +3%-units for S_{RCP} .
2. Delphi: "Increasing use of commingled collection."
 - This can be considered to be one of the enabling factors behind the high collection rates. It will increase the need for sorting in general, thus widening the gap between S_{RCP} and S_{RCPF} at the marginal Q.
 - S_{RCPF} : elasticity at $P = 55 \text{ €/t}$ (Q_{MWP}) increased from 0.15 to 0.3 (S_{RCP} has 0.1).
3. Delphi: "The uti-rate in containerboards will stay flat."
 - The market share of RCP in containerboards in Europe is expected to stay more or less flat. While the main grades consuming MWP are containerboards and to a lesser extent recycled cartonboards and other packaging, there is no indication available that RCP will increase its market share in these grades.
 - D_{MWP} : The k-value remains at 14%-units, i.e. no horizontal shift.
4. Delphi: "Some increase is expected in substitute prices (in real terms)."
 - The panel expects an increase in the factor costs of mechanical pulp⁵⁶ and also an increase in the price development of chemical pulp⁵⁷. Thus the industry's paying capacity for RCP should rather increase than decrease. In the literature, the cross-price elasticity between RCP and virgin fibre is most often estimated to be rather low 0.1–0.2 (Nesstor 1992, Rehn 1995 as well as Hseu and Buongiorno 1997, both in Lundmark and Söderholm 2003).
 - D_{MWP} : vertical shift of +15 €/t⁵⁸.

⁵⁶ 4.5% per year nominal growth in electricity and 2.7% per year in pulpwood. See Appendix IV.

⁵⁷ 3% per year nominal growth in long-fibre chemical pulp. Here the same is assumed for short fibre.

⁵⁸ Assuming 25% of substitution via mechanical pulp and 75% via chemical pulp and 0.15 as cross-price elasticity.

5. Delphi: “The SRF market is expected to continue its strong growth.”
 - SRF demand is expected to grow at a higher rate than supply. Some lack of waste will emerge. The price of SRF will increase. This direction is clear, but *the magnitude of change remains highly speculative*.
 - D_{SRF} : horizontal shift of +4%-units, roughly doubling the demand by 2020.
 - S_{SRF} : horizontal shift of +2%-units, roughly half of the increase in demand, thus reflecting the expected shortage of waste.
 - The RCF content of SRF is held constant (a third).
6. Delphi: “Ethanol from waste and similar advanced W-t-E concepts remain wild cards.”
 - In 2020, the SRF market will still be based on combined heat and power production, integrated with industrial heat sinks such as RCF-based paper mills. No drastic changes in the paying capacity of SRF users are expected.
 - No change in D_{SRF} due to technology.
7. Delphi: “The CO₂ cap&trade mechanism continues to operate in Europe, price level 25–30 €/t.”
 - This represents an increase of 10–15 €/t compared with the present situation. This implies a price benefit of 5 €/MWh⁵⁹ for renewable energy production and 2 €/MWh for SRF (we assume 40% bio-content). Converted to fuel wood price it means 15–20 €/t and to SRF price approx. 10 €/t increase potential.
 - D_{SRF} : vertical shift of +10 €/t.
 - Increase of wood price already considered as part of item #4.

Yet another central assumption derived from the Delphi study for 2020 is that, while local demand for MWP is not expected to grow in relation to Q_{MAX} , and supply is still expected to grow a bit, exports are anticipated to continue on a strong rising trend resulting in a continuing rise of RCP real prices. This is reflected in the results displayed by Figures 6.10–6.13 (see next page). The figures employ three variants of MWP price because of a lack of data to cover developments in the global supply-demand balance (as discussed in Chapter 6.1, it is the global market that also sets the price level of MWP in Europe). The Delphi panel focused on developments in the European market, but yielded an overall expectation that the global RCP demand will keep growing faster than the supply. Therefore Figure

⁵⁹ In practice this depends on the fuel being replaced. With coefficients of Statistics Finland (2011) replacing coal by renewable fuel gives 5 €/MWh benefit if the CO₂ price increases from 15 to 30 €/t CO₂.

6.10 portrays the starting point for the analysis and Figures 6.11–6.13 assume three variants of the ROW market development that lead to different price levels for MWP (low 110 €/t, medium 150 €/t and high 200 €/t).

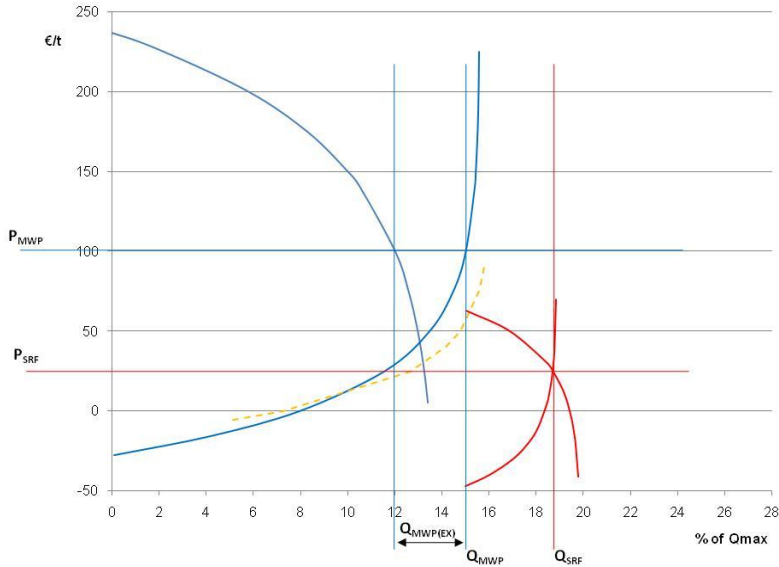

Figure 6.10. Estimation of the present market status.

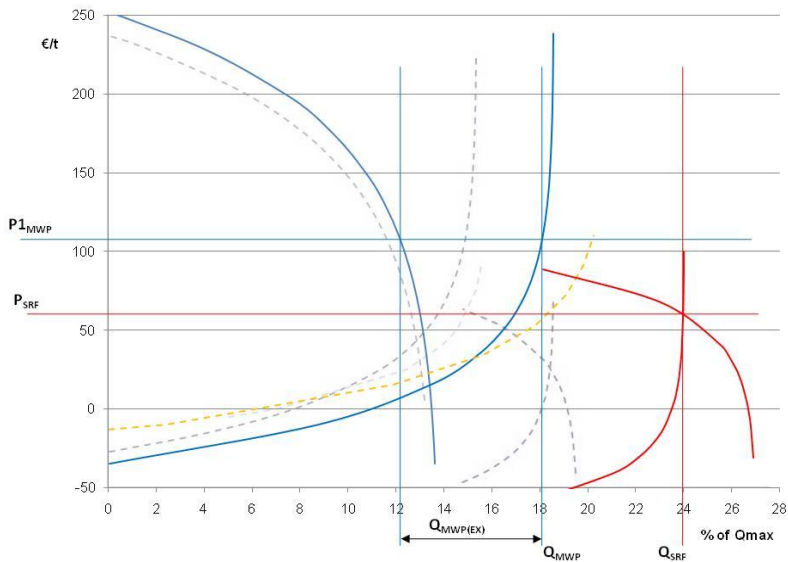

Figure 6.11. Main scenario 2020 ($P_{MWP} = 110$ €/t).

6. Testing the proposed S/D model with Delphi outputs

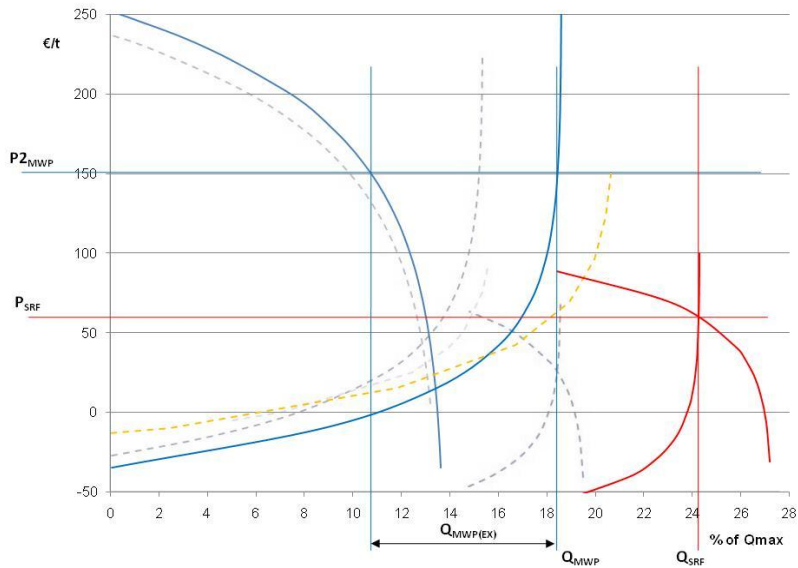

Figure 6.12. Main scenario 2020 ($P_{MWP} = 150$ €/t).

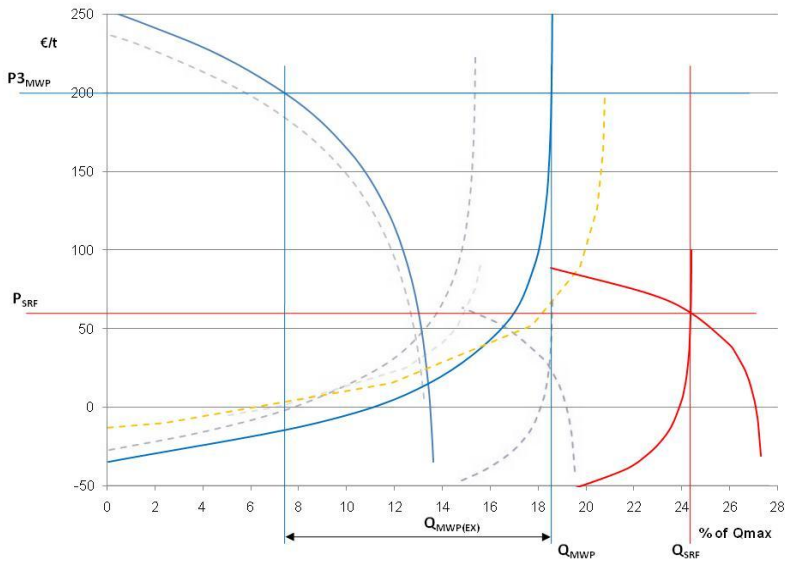

Figure 6.13. Main scenario 2020 ($P_{MWP} = 200$ €/t).

Figures 6.14 and 6.15 summarise the key findings of the three main scenarios for 2020. Perhaps somewhat surprisingly, the clear increase in substitute prices and the still quite substantial increase in RCP collection appear incapable of securing

the availability of MWP volumes for the domestic market; i.e. the proportion of Q_{MWP} consumed on the local market clearly decreases with increase in price. At an MWP price of 110 €/t local demand roughly holds its share of the quantity, while at a 150 €/t price level about 10% less than today would be consumed locally. At an MWP price of 200 €/t local consumption would decrease by more than a third.

The development of the SRF market remains highly speculative. Using the assumptions listed above, the SRF market would increase by 50% (from about 4%-units of Q_{MAX} to 6%-units of Q_{MAX}) and prices would considerably increase, clearly narrowing the gap between S_{RCPF} at marginal quantity Q_{MWP} and P_{SRF} . At an MWP price of 110 €/t this scenario would already indicate a small bleed to the fuel market, while at 150 €/t the markets would be roughly at par. This conclusion on the main scenario continues to be in line with the more intuitive expert opinion generated by the Delphi panel. The assumed volume development is in line with the findings of Sipilä et al. (2009) in their market study for high efficiency CHP and waste-based ethanol, and rather on the conservative side in comparison to the market scenarios presented by ERFO president, Mr. Straetman (2010) in his speech at the 2010 Helsinki SRF congress.

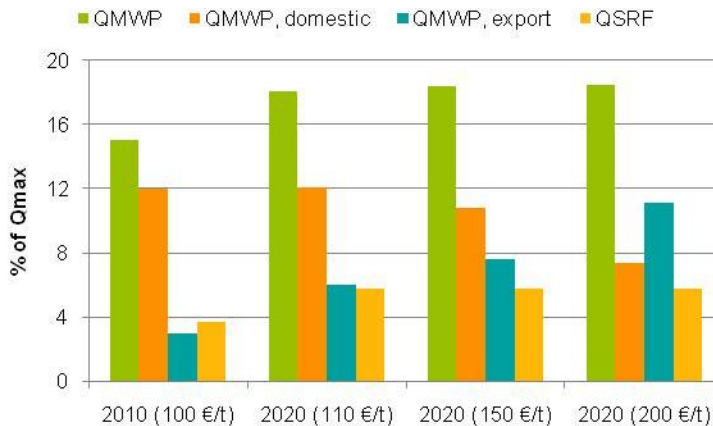

Figure 6.14. Development of MWP and SRF quantities 2010–2020.

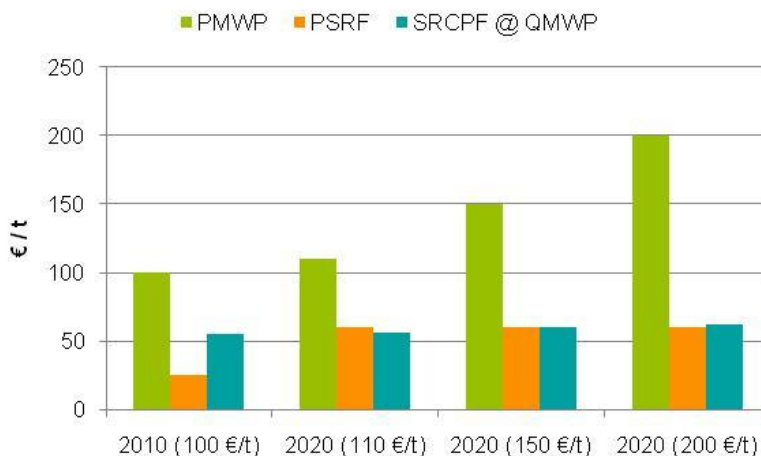

Figure 6.15. Modelled development of the MWP and SRF price 2010–2020.

6.3.2 Alternative scenarios for the year 2020

The alternative scenarios that arose from the Delphi panel can be condensed into the following six cases:

1. RCP starts to lose market share to TMP due to its price development

This alternative refers to a situation where TMP has widely become a cheaper raw material component than RCP in newsprint manufacturing. Most likely it would simultaneously imply a similar status in the manufacturing of magazine grades. The pre-requisite for this scenario is obviously either a very high price level of ONP/OMG or suddenly reduced factor costs in TMP manufacturing. As the latter sounds very unlikely, this situation would most likely be induced by strong export demand for RCP. Because ONP/OMG is, to a significant extent, a sorting product of MWP, a drop in ONP/OMG demand would probably increase the share of MWP within RCP grades, thus improving the MWP supply and reducing its price⁶⁰. This, in turn, would bring the P_{SRF} and S_{RCPF} closer to each other at the marginal quantity Q_{MWP} .

Based on the model and the main scenario parameters, the following estimations can be made:

- The quantity of ONP/OMG is presently about 18% of Q_{MAX} and about 2 units of MWP are required to sort 1 unit of ONP/OMG. Thus already a 5% drop in the newsprint uti-rate from 90% to 85% would generate about a

⁶⁰ Marginal quantities of ONP/OMG grade are produced by sorting MWP.

2%-unit horizontal shift in S_{MWP} . (Whether such a drop is likely or not, is another question.)

- A further increase in S_{MWP} by 2%-units of Q_{MAX} , *ceteris paribus*, would translate into a price decrease of 150 €/t to 136 €/t (using the main scenario with a 150 €/t market price as the basis and an approximate of S and D schedules in the ROW market⁶¹). If the assumptions of SRF market development simultaneously held, this change might well be enough to generate a small bleed from the fibre market to the fuel market ($P_{SRF} > S_{RCPF}$ at the marginal quantity Q_{MWP}).
- It should be noted that a further *increase* in the uti-rate of newsprint or magazine grades would have the opposite impact by effectively eroding the MWP supply.

2. Substitute (Virgin fibre) prices keep declining

Historically, the real prices of both chemical pulps and pulpwood (in Sweden) have been on a declining trend. However, the main scenario resulting from the present expert panel expects that the real prices of both chemical pulp and pulpwood will turn to at least a modest increase.

Should the downstream demand for paper products decline without a rise in factor costs to balance it, the real prices of virgin fibre might continue their long-term decline⁶². In the main scenario a +15 €/t vertical shift in D_{MWP} was assumed as a result of moderately increasing substitute prices.

- Flat nominal price development, i.e. about 1.5% p.a. decrease in real terms would mean a 14% decrease by 2020. Using the same assumptions and cross-price elasticity as in the main scenario, this would mean a vertical shift in the demand schedule for MWP of about -10 €/t.
- The resulting change against the main scenario of 150 €/t MWP price is a slight drop, approximately 8 €/t, calculated by using the same S and D schedule for the ROW area as in the previous scenario. Again, if the assumptions of SRF market development held, this change could be enough to generate a small bleed from the fibre market to the fuel market ($P_{SRF} > S_{RCPF}$ at the marginal quantity Q_{MWP}).

⁶¹ D_{ROW} is arbitrarily given an own-price elasticity of 0.03 at 50 €/t and 0.5 at 150 €/t. Elasticities for S_{ROW} are respectively estimated at 0.35 and 0.1.

⁶² In theory, the decline could also accelerate as a result of softening end-product demand. However, the Delphi panel considered the continuation of the historical price trend to be the main alternative.

3. Considerable increase in substitute (Virgin fibre) prices

Despite the historical price trends and the dominant expert opinion of only a modest increase in virgin fibre real prices, there were also arguments for a considerable increase in the virgin fibre price trend. Such views were based on the two alternative scenarios mentioned in Table 5.3, namely the general competition for biomass, which would cause a hefty increase in the factor costs of virgin fibre manufacturing, and the so-called “bio-refinery” scenario, which could be argued to increase the own-price elasticity in pulp supply in the longer term.

What could be considered a suitable increase? Some panellists believed that general competition for biomass would be so strong that pulp prices could be as high as 1100 \$/t by 2020. This is about double the long-term price trend, and would mean almost 75% growth, even if depreciated by 1.5% per year. The highest growth estimates for the factor costs of mechanical fibre were +40% in real terms for pulpwood and +50% for electricity. This converts to about +80€/t in real terms by 2020⁶³. Using these figures and the same assumptions of cross-price elasticity as before would result in an impact of about +50 €/t in the demand schedule.

- A +35 €/t vertical shift in the MWP demand schedule (+15 €/t is already covered by the main scenario) would result in only a 9 €/t (+6%) increase in the MWP price from 150 €/t of the main scenario to 159 €/t. The large ROW market acts as a huge damper on local supply/demand changes. A hefty demand schedule increase of +35 €/t in a market that is responsible for about a third of the supply and a quarter of the demand would impact the global MWP quantity traded by only a fraction of a per cent.
- If a similar shift was also experienced in ROW demand (*Scenario 3b*), the increase in the price of MWP would be about +50 €/t (+33%). This is the more likely scenario, of course, as chemical pulp price fluctuations are global by nature. This is less true for mechanical pulps, but their share in the “substitute basket” is smaller than that of chemical pulps.

4. Strong growth of W-t-E seriously hampers growth of the RCP collection rate

The expert panel forecast the RCP collection rate to be saturated at 75–80%. This outcome is used as such in the main scenario that was discussed in section 6.3.1. At the same time the panel expects the W-t-E market to continue the active development witnessed throughout the 2000s. This is also considered a *strong prospective trend* in this study. The main scenario outcome with a 77.5% collection rate and the doubling of SRF demand by 2020 would mean +3.5%-unit growth in Q_{MWP} and +2%-unit growth in Q_{SRF} to about 6% of Q_{MAX} by 2020. If we assume

⁶³ Assuming 2 m³ per 1000 kg and a yield of 0.8 to TMP. Nominal price increase depreciated by 1.5% per year.

that, in the same time period, the other RCP grades grow at half the pace of MWP, we get an additional 7%-units of growth against Q_{MAX} , leaving only about 10% of Q_{MAX} for disposal and other utilisation. It is likely that such a figure would already be too low and would, in practice, imply slower-than-expected growth of the RCP collection rate. Probably a little bit more than 10% should still be left for disposal and other utilisation by 2020.

- In the main scenario we used a +3%-unit horizontal shift in S_{RCP} . If we reduced that shift by a third down to +2%-units, it would correspond to an approximate 3% reduction in the total RCP collection rate and thus leave 12–13% of theoretically maximal attainable RCF content for disposal and other utilisation.
- This tighter supply would, *ceteris paribus*, result in a relatively small price increase of about 6 €/t of MWP in comparison to the main scenario of 150 €/t (+4%). Again, we witness the damper effect of the large ROW market.

5. European targets for reduction of CO₂ emissions are cut

The almost unanimous forecast of the Delphi panel was that some kind of CO₂ cap&trade system will continue to exist in Europe and that the price level of CO₂ credits will be 25–30 €/t, i.e. an increase of some 10–15 €/t from the present level. This forecast is included in the main scenario for 2020 as a *strong prospective trend*.

However, there were a few comments from the panel along the lines that, in the event of economic slowdown and an accelerating escape of manufacturing industries to countries with no CO₂ cap&trade burdens, EU governments might be forced to cut their CO₂ emission reduction targets or to abandon the cap&trade system altogether. It has been calculated that the forecast increase of 15 €/t in the CO₂ credit price level translates to about 5€/MWh benefit for renewable fuels (c.f. assumption #7 under 6.3.1). If this benefit is assumed to directly transfer to the wood price, we can easily simulate its effects.

- Halving the CO₂ credit price level from the forecast 25–30€/t to the present level of 12–15 €/t would mean a price impact of 15–20 €/t for wood. Assuming a share in pulp costs of about 40% and cross-price elasticity of 0.2, it would mean a downward shift in the MWP demand schedule of about 2 €/t in comparison to the main scenario.
- Totally reducing the price impact of CO₂ cap and trade systems would mean a downward shift in the MWP demand schedule of 4 €/t.
- A downward shift in the MWP demand schedule of 4 €/t compared with the main scenario would result in a price decrease of only a negligible 1 €/t.

Another question is whether lower or zero prices for CO₂ credits would impact the general interest in investing in industrial CHP applications of W-t-E. This would be reflected in slower-than-anticipated development of D_{SRF} and consequently in

clearly lower SRF prices, as the market appears to be supply-limited (c.f. discussion of Figure 6.7).

6. Large-scale realisation of EtOH from waste (or similar)

The expert panel considered the proposed “EtOH from waste” concept (Urban Ethanol, see section 3.3.2) as an interesting wild card for the future, and it is here considered as one of the alternative scenarios for market development. Compared with the main scenario, which assumes continuation of strong growth of W-t-E in industrial CHP settings, the Urban Ethanol concept introduces a value-added, storable fuel product that appears to be really exciting politically, as it would help to mitigate climate change in the very challenging area of transportation fuels and reduce the oil dependency of our economy, although on quite a minor scale. Thus, the Urban Ethanol concept could significantly accelerate W-t-E development and even provide direct competition to poor-quality RCP flows.

In order to assess the impact of this scenario on the RCF market, one first has to understand what kind of paying capability the UE concept would have for SRF or MWP. Section 3.3.2 presented two main variants of the UE concept – a stand-alone unit (UE1) and a unit integrated with the operations of an RCF-based paper mill (UE2), the latter showing clearly higher profitability. Using the relatively simple financial calculation presented in Chapter 3, the following observations can be made:

- When EtOH revenue is set at 80 €/l and biogas at 40 €/MWh, the UE1 concept needs money with SRF to claim a threshold ROCE of 10%. However, the UE2 concept can tolerate an SRF price of 30–40 €/t. In comparison, the normal CHP use of SRF in a paper mill environment can tolerate an SRF price of about 20–25 €/t with similar assumptions. Interestingly, this is, at least regionally, the price level already today (interview of Hietanen L. 2011).
- Besides RCF, the main alternative feedstock for large-scale bio-ethanol production would be lignocelluloses obtained from wood. The EtOH production costs for lignocellulosic EtOH are in the range of 2€/l. If a “feeding tariff” of 2 €/l was granted to producers of EtOH from waste, UE1 would tolerate an SRF price of 70–80 €/t, i.e. a little higher than the price level forecast in the main scenario for SRF. (On the other hand, conventional W-t-E investments appear unfeasible with much higher than the present price level, *ceteris paribus*). With the 2€/l feeding tariff, UE2 would tolerate an SRF price of about 120–140 €/t (approx. 25–30 €/MWh).
- For stand-alone “EtOH from waste” production, the typical RCF content of SRF (roughly a third) is clearly sub-optimal. Much lower non-fibrous combustible reject content, perhaps 15–25%, would be enough to provide the energy needs of EtOH conversion. Poor-quality RCP supplemented with some SRF would be a perfect combination. If the RCF content of the feedstock were increased to about 60% by mixing poor-quality RCP in SRF, for example, the paying capability of UE1 for such feedstock would be above the projected MWP price level of 150 €/t, assuming a feeding tariff of 2€/l. If

there were no feeding tariff and EtOH was sold at 80 €/l, the paying capacity of UE1 would be around 50–60 €/t for its combined feedstock.

The main conclusion from the EtOH-scenario is, that its paying capacity is highly dependable on the political decisions related to feeding tariffs for EtOH (also bio-gas). At least those units integrated with paper mills would enjoy the option to combine poor quality RCP lots in EtOH feedstock, still having good paying capability for both its RCP and SRF needs. In such conditions, there is a considerable risk of RCF bleeding from fibre to fuel market (c.f. Figures 4.13–4.16).

Summary of the alternative scenarios

Figures 6.16 and 6.17 summarise the main projected impacts of the five first alternative scenarios. The impacts of alternative six (Urban Ethanol) are left blank as, depending on the political support received for it, the concept’s paying capability for various feedstocks remains totally open. Its effects could range from just reinforcing the development already witnessed on the SRF market to totally devastating effects on the RCP market – e.g. the MWP price climbing to 250 €/t. In general, there appears to be no foreseeable scenario under which the price of RCP would turn to a major decline.

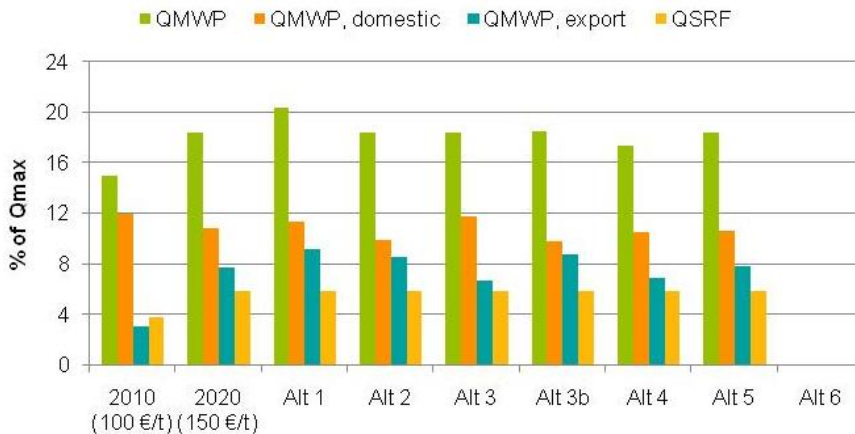

Figure 6.16. Development of MWP and SRF quantities in line with the studied alternatives to the main scenario for 2020.

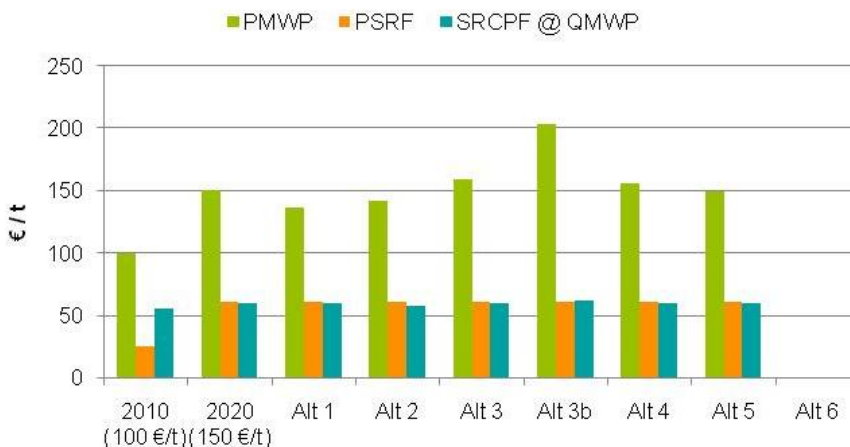

Figure 6.17. Modelled development of the MWP and SRF price 2010–2020.

6.3.3 Additional “post-Delphi” considerations

In 2011, after the Delphi panel had finished its work, at least two factors have arisen in public that may have a major impact on the 2020 scenarios for the composite RCF market. They are the “mineral oil” crisis in food packaging (c.f. section 3.3.1) and the Fukushima nuclear power plant meltdown and the consequent political decision to close all German nuclear power plants by 2022. A brief elaboration of the possible consequences follows:

1. “Mineral oil” crisis

Kersten et al. (2011) have identified the actions required to mitigate the migration of mineral-oil-saturated and aromatic hydrocarbons from packaging into foodstuffs. They include stricter control over RCP quality and the use of additional inner-packaging with barrier functions. But as the undesired hydrocarbons mainly originate from inks found in RCP, the most effective and simplest measure is undoubtedly the increased use of virgin fibre (ibid.).

What could the impact on the composite RCF market be? Let’s make some assumptions:

- The current share of RCP in cartonboard packaging in Europe is about 50% of total consumption, or about 6 Mt/a. Let’s assume that a third of this is converted to virgin fibres by 2020, the rest remains with RCP and other means are utilised to limit the migration. This will free 2Mt/a of RCP for other uses. This amount corresponds to about 2–3% of European supply.
- Considering the ROW market’s buffer effect, the price impact of a 2 Mt reduction in European demand will be relatively small, about –15 €/t – using

a base line price of 150 €/t for MWP and the same assumptions concerning the ROW market as in other scenarios of this chapter. This is not a huge impact, but definitely increases the possibilities of bleed from the fibre market to the fuel market.

- Thus the big question is not the magnitude of a European phenomenon (mineral oil crisis and eventual shift in favour of virgin fibre) on the global market, but whether a similar development would take place on other main markets such as China and the US. ***This would have a dramatic effect on the market and would probably result in a more permanent shift on the RCF market in favour of the fuel market.***

2. Closure of German nuclear power plants by 2022

The meltdown of the Fukushima nuclear power plants in Japan as a consequence of the March 11, 2011 earthquake and tsunami has caused major energy policy turmoil in Europe. In May 2011 the German government set the end of 2022 as an irreversible final date for the switch-off of its last nuclear power plant. Considering that the nuclear plants currently account for about 30% of Germany's electricity supply and that the German economy has a dominant role in the European energy market, the possible outcomes of this decision definitely include a radical increase in energy prices.

Of a special concern is the question of how Germany will be able to deal with its CO₂ reduction obligations. After the decision to close all nuclear capacity, very few alternatives are left open. Wind energy is incapable of following load, and is thus never sufficient alone. Applying carbon capture and storage to existing coal-fired power plants is estimated to easily double the electricity price. Torrefaction of wood⁶⁴ and use of the fuel product in coal-fired power plants is one technically feasible option that would cut CO₂ emissions at the power plant by 80%. However, its large-scale utilisation in coal-fired power plants would make wood prices skyrocket (interview of Sipilä K. 2011).

Thus a relevant question emerges: how would a radical increase in European energy prices affect the RCF market?

At least the following likely consequences can be identified:

- Radically higher energy costs will further increase interest in investing in energy self-sufficiency at paper mills. Logically, this should mean a further boost for the implementation of W-t-E at paper mill sites.

⁶⁴ Torrefaction is a mild form of pyrolysis treatment in which wood is treated thermo-chemically under atmospheric conditions and in the absence of oxygen. Typical temperatures are 200–300 °C. Combined with densification it yields high calorific fuel that can be co-combusted with e.g. coal (Kiel 2007).

- The prices of all fuels, including oil, wood and SRF, are likely to increase. This will probably imply an increase in the virgin fibre prices for the paper industry and consequently the price for RCP.
- Presently, it is impossible to make meaningful quantifications of the impact of the German nuclear decision on the RCF market, but qualitatively speaking it will mean higher prices for fuels, virgin fibres, and for RCP as well. ***How it will impact the balance between the fibre markets and the fuel markets for RCF remains unclear.*** Most likely it will not reverse the ongoing trends in end-product demand, i.e. the growth of fibre-based packaging and the decline of printing papers – nor the trend to build competitive W-t-E capacity at paper mill sites.

6.4 Conclusions from testing the model

The objective of this chapter was to define answers to the following research questions:

Q7: What are the main and alternative scenarios for the future development of the RCF market?

Q8: Can the scenarios and the conditions under which they will be realised be meaningfully quantified by using the constructed model?

A further objective was to return to the following research questions that were only partially answered by the previous chapters:

Q4: What does the model of the composite RCF market look like?

and

Q6: Are any such market phenomena likely in the future that might suggest increasing interplay between the markets for the use of discarded-paper-containing flows as raw material and as fuel?

A comprehensive answer to Q7 was provided by sections 6.3.1 and 6.3.2. Section 6.3.1 quantified a main scenario for RCF market development against three different market price levels (c.f. Figures 6.10–6.15):

- Conclusions on the price development for the marginal RCP quantities can only be made based on analysing the developments on the export market. As the scope of the present study was to analyse the market development in Europe, the quantification of the model had to assume three different market price levels as the starting point. These were set at 110, 150 and 200 €/t.
- Depending on the market price level, MWP utilisation in Europe will either stay roughly at its present level or turn to a decline. Against the Delphi outcomes and the model, no increase in the European RCP utilisation rate can

be expected. The scenario with the MWP price at 200 €/t would imply a radical reduction in the uti-rate, perhaps even by a third (assuming that other RCP grades behave somewhat analogically to MWP).

- In the main scenario, the SRF demand is assumed to continue its rapid growth leading to a very high price level of around 60€/t.
- A shortage of SRF is also expected by 2020 (being the very reason for the unhealthy high price level)
- Overall, almost all the growth potential in Q_{RCP} will be consumed by 2020.
- The expert panel did not expect any significant RCP quantities to move into fuel use. This is supported by the chosen model and set of parameters – provided demand development in the export area continues strong; i.e. if the price of MWP stays above about 150 €/t. The local RCP demand development can probably not alone sustain the gap between the SRF price and S_{RCPF} at the marginal quantity Q_{RCP} .

Section 6.3.2 used the model to analyse the impacts of six different alternative scenarios on the composite RCF market. The following conclusions can be made:

- If RCP started to lose its market share in the manufacturing of e.g. newsprint and magazines, more quantities of MWP would become available, thus driving its price down. A 5–10%-unit drop in the RCP uti-rate in these grades would probably be enough to create some bleed between the fuel and fibre markets for MWP, if we otherwise hold to the assumptions of the main scenario.
- If substitute prices keep flat on a nominal basis and we consequently estimate a 1.5% annual decrease in real terms, the industry's paying capacity for MWP will decrease to a level that might again indicate some bleed between the fibre and fuel markets for MWP, if we otherwise hold to the assumptions of the main scenario.
- If there was a substantial increase in the substitute prices by 2020, we would see either a very small impact on the MWP price or, if the increase was global (which is more likely), a more radical increase. Such an increase would consequently increase the clearance between the fibre and fuel markets in Europe.
- If the investment activity in industrial CHP based on W-t-E energy continued at its present rate or a higher rate in Europe, we would probably see the RCP collection rate become saturated a little sooner than expected, and at a little lower level than expected. The same might actually happen to the SRF supply. In other words, ***we might well witness a shortage of waste by 2020.***
- The impact of the CO₂ credit price is relatively small in the composite RCF market.

- The paying capacity of the Urban Ethanol concept is highly dependent on political decisions. Depending on the price level for EtOH (possibly a feeding tariff) an option to combine poor-quality RCP lots in the EtOH feedstock might emerge, especially for those units that were built at paper mill sites. However, without significant feed tariffs or tax benefits, a producer price at a level of 40–50 €/l is not enough for large-scale realisation of the concept, not even as integrated operation.

The results gained in sections 6.3.1 and 6.3.2, complemented with two “post-Delphi” considerations in 6.3.3, can be considered to outline a meaningful and diverse picture of future scenarios for the composite RCF market in Europe and thus demonstrate the value of the model and the Delphi approach. While the limitations in both the scope of the Delphi study and the available data forced quite a few rather weak assumptions to be made in the quantifications, the model was still demonstrated to be useful for meaningful quantifications and thus the formal answer to Q8 is yes.

An answer to the research question Q4 – “What does the model of the composite RCF market look like?” was sketched in its qualitative form in section 4.4. Chapter 6 completed the answer to Q4 by quantifying the conceptual model presented in section 4.4. The model quantification has been tied both with market behaviour reported in the field of econometric research and with the outputs of the foresight study carried out as part of this research. Naturally, the quantification of the model never provides accurate numeric answers to all imaginable questions relating to the market. Nevertheless, this chapter has demonstrated a way of quantification that is enough to provide indicative numeric information.

A formal answer to Q4 is:

- i. The model of the composite RCF market contains three main components: 1) RCF traded as RCP (paper-making raw material use), 2) RCF included as a component in the SRF type of materials (feedstocks for various energy utilisations), and 3) RCF still found among various waste flows earmarked for disposal (c.f. Figure 4.11).
- ii. The RCP market should be further broken down to its main components (c.f. Figure 6.1).
- iii. The tie-in of the cascaded fibre and fuel markets is made possible by two new concepts, Q_{MAX} and S_{RCPF} . In the proposed model each quantity is presented by the weight of its discarded paper content, summing up to the Q_{MAX} , the maximum attainable quantity. Furthermore, the shadow supply schedule of RCP as fuel makes it possible to compare the available surplus on the fibre and fuel markets for the marginal RCP quantities.
- iv. The distinction between the domestic and export markets for RCP plays a major role. In order to model price behaviour, factors affecting the global market must be recognised and their development trends must be understood.

- v. One meaningful example to model the interplay between the marginal RCP quantities and the SRF market is provided by the equations 1–10. Parameters for these equations can be extrapolated based on previous research and market observations, including the comments received from the Delphi panel. The parameters used in each demand and supply schedule are included in Figures 6.4–6.9.

By using the results presented in Chapter 6 we are also able to complete the answer to Q6 – “Are any such market phenomena likely in the future that might suggest increasing interplay between the markets for the use of discarded-paper-containing flows as raw material and as fuel?”

Tentatively, based on the Delphi panel outputs, the answer was somewhat mixed, but more yes than no. Based on the presented quantification of the main scenario and especially the alternative scenarios, ***the answer remains yes***. The interplay between the fibre and fuel markets is already a reality, at least via the SRF market growth that consumes a larger and larger chunk of growth potential in RCP supply. Moreover, direct competition between fibre and fuel might emerge in light of most of the alternative scenarios. By 2020 a real price of approximately 150 €/t for MWP appears to be a level that would protect MWP’s usage as fibre.

The model, and especially the parameters used in it, obviously leaves a lot of room for discussion. As with any model, the results are dependent not only on the accuracy of the model, but also on the quality of the inputs. Nevertheless, this attempt to quantify the findings of this study has proven the model useful in the meaning of constructive research.

7. Conclusions

This chapter presents the conclusions of the research. It is logical to start such a discussion by summarising the answers to the research questions outlined at the beginning of the study. The answers are followed by a critical evaluation: has the study met all the scientific criteria set for it? Based on these, the epistemic and practical utility of the research can be summarised. Finally, the chapter ends with a discussion of the validity and reliability of the findings.

7.1 Answers to the research questions

Q1: Is there a need for a model of the composite RCF market?

Chapter 3 elaborated in detail some of the recent and foreseeable trends in the RCF-based paper industry, including quite a few intriguing applications of W-t-E at mill sites. Three main reasons for analysing the behaviour of the composite RCF are made evident: 1) Growth in utilisation of RCP in papermaking continues strong, while the growth in supply is gradually expected to saturate – thus indicating a tight supply, 2) investments in modern W-t-E concepts at paper mill sites are financially very attractive and the trend to build W-t-E boilers for rejects and the SRF-type of fuels is expected to continue, and 3) new concept ideas like Ethanol from waste promise even better returns. Considering that the growing popularity of SRF-type fuels will erode the growth potential in the already tight RCP supply, and that RCF-based EtOH manufacturing might, in the future, directly compete for at least the poorest-quality RCP fractions, the need to understand the behaviour of the *composite RCF market* becomes clear. The model of the composite market needs to include the use of RCF both as fibre raw material and as fuel.

Yes – there is a need for a model of the composite RCF market that covers its use both as fibre raw material and as fuel.

Q2: What are the criteria for the model of the composite RCF market?

From the substance or practical relevance point-of-view, the model of the composite RCF market must be able to shed light on typical questions stemming from the analysis of the pre-identified trends listed in Table 3.4 (p. 85):

-
- Will the competitive advantage of RCF over virgin fibre be sustained?
 - What will the impacts of continued investments in W-t-E at paper mills be?
 - What if the fibre content in waste fuels could be utilised as an additional raw material component? What if that happened on a large scale?
 - What will the impacts of an increase in the fuel use of wood be?
 - What if the fibre content in waste fuels could be utilised in EtOH conversion? What if that happened in large scale?
 - What will the impacts of spreading commingled collection be?
 - What will the impacts of increasing reject disposal cost be?

Model of the composite RCF market must be able to deliver practical utility in the form of better understanding of the interplay between the RCP market and the fuel market in a valid and reliable way.

Q3: Are there pre-existing theoretical models that satisfactorily meet the need to understand the composite RCF market?

Past research in the field of econometric analysis has mainly concentrated on assessing the efficiency of various policy instruments, typically aimed at increasing recycling. The equations and mathematical approach can prove useful, but for a clear understanding of the basic interplay between the fibre and fuel markets, a simplified, qualitative model is first called for. A new approach is needed in order to put the different markets related to the treatment and utilisation of discarded paper in relation to each other. Such a model can be used as a tool to analyse the composite RCF market, also considering the possibility of quite fundamental changes in market conditions, and thus it enables the research objectives of this study to be met.

Previous theories in the field of price theory and econometric analysis are not capable of providing clear answers to the research questions of this study.

Q4: What does the model of the composite RCF market look like?

This is the very central research question of this study. After lengthy reasoning, interaction with an expert panel and testing of the model, this research ends up proposing a quantifiable model with the following features:

- i. The model of the composite RCF market contains three main components: 1) RCF traded as RCP (paper-making raw material use), 2) RCF included as a component in the SRF type of materials (feedstocks for various energy utilisations), and 3) RCF still found among various waste flows earmarked for disposal (c.f. Figure 4.11).
- ii. The RCP market should be further broken-down to its main components (c.f. Figure 6.1).

7. Conclusions

- iii. The tie-in of the cascaded fibre and fuel markets is made possible by two new concepts, Q_{MAX} and S_{RCPF} . In the proposed model each quantity is presented by the weight of its discarded paper content, summing up to the Q_{MAX} , the maximum attainable quantity. Furthermore, the shadow supply schedule of RCP as fuel makes it possible to compare the available surplus on the fibre and fuel markets for the marginal RCP quantities.
- iv. The distinction between domestic and export markets for RCP plays a major role. In order to model price behaviour, factors affecting the global market must be recognised and their development trends must be understood.
- v. One meaningful example to model the interplay between the marginal RCP quantities and the SRF market is provided by the equations 1–10. Parameters for these equations can be extrapolated based on previous research and market observations, including the comments received from the Delphi panel. The parameters used in each demand and supply schedule are included in Figures 6.4–6.9.

Q5: What phenomena are likely to affect the RCF market in the future?

This research incorporates a focused Delphi expert panel that was set up with three important purposes:

- i. to gain support and evidence for the constructed S/D model; to iterate the model as needed.
- ii. To gain qualitative insight on the phenomena likely to affect the RCF market in the future.
- iii. To create a basis for preliminary quantification of the model.

As a result to the second objective, the panel delivered main and alternative scenarios for the market development: These scenarios are listed in Tables 5.2.–5.5 and further used together with the model of the composite RCF market.

Q6: Are any such market phenomena likely in the future that might suggest increasing interplay between the markets for the use of discarded-paper-containing flows as raw material and as fuel?

Based on the findings of the Delphi panel, the answer to Q6 was somewhat mixed, but *more yes than no*. Based on the presented quantification of the main scenario, and especially the alternative scenarios, the answer remains yes. The interplay between the fibre and fuel markets is already a reality, at least via the SRF market growth that consumes larger and larger chunk of growth potential in RCP supply. Moreover, direct competition between fibre and fuel might emerge in light of most of the alternative scenarios.

Q7: What are the main and alternative scenarios for the future development of the RCF market?

A comprehensive answer to Q7 was provided by sections 6.3.1 and 6.3.2. The main scenario assumes rather high price levels for both MWP and SRF in 2020. It also leaves a notably small amount of RCF for final disposal and other utilisations. The alternative scenarios complement the picture of market development with variations in substitute price development and alternative developments in W-t-E. In the future, RCP will be more like any other raw material. Prices will continue to vary, but the extreme low levels characteristic of secondary raw materials will probably disappear, as in the future the fuel market will also have significant paying capability for RCP.

Q8: Can the scenarios and the conditions under which they will be realised be meaningfully quantified by using the constructed model?

Based on the above-described quantified results and top line conclusions the answer is yes.

Q9: Are there analogical problems where the combination of the proposed composite market model and scientific foresight are applicable and useful?

This question will be discussed in section 7.3 (p. 170).

Referring back to the original research objectives of this study, the following conclusions can be made:

- i. **Confirm the relevance** of the research issue and **establish criteria** for suitable tools and theories in the study of the RCF market.
⇒ *This objective has been successfully met by the answers to Q1 and Q2.*
- ii. **Identify suitable tools and theories** that can be used to study how the market deals with competing demands that tolerate different physical forms of RCF; i.e. including trade of discarded paper as RCP, trade as part of the various fuel streams, other forms of utilisation, and the final disposal.
⇒ *This objective has been successfully met by the answer to Q3.*
- iii. In the event that gaps are found in the existing theories and understanding of the research issue, **construct a model of the composite RCF market.**
⇒ *This objective has been successfully met by the answer to Q4.*
- iv. **Gain foresight of the phenomena that are likely to take place on the RCF market** in a time perspective that corresponds with the strategic planning needs of the pulp and paper industry, i.e. about 10 years.
⇒ *This objective has been successfully met by the answers to Q5 and Q6.*
- v. Jointly apply the model and the achieved foresight – **what is likely to happen on the composite RCF market under different conditions.**
⇒ *This objective has been successfully met by the answers to Q7 and Q8.*

- vi. **Evaluate the epistemic and practical utility** of the results and chosen research approach – how valid and reliable are the results, and whether such a combination of composite market model and scientific foresight could find applications in approaching other, analogical problems.

⇒ *This objective will be discussed separately in section 7.3.*

7.2 Evaluation of the research

Evaluating a piece of research involves analysing how well it meets the criteria set for it. In the case of this research we must consider three different aspects: 1) the criteria for constructive research, 2) the practical criteria for the construct (S/D model of the composite RCF market) and 3) the criteria for scientific foresight.

7.2.1 Theoretical criteria for constructive research

The commonly used criteria for evaluating constructive research are (Kasanen, 1993 and Lanning, 2001, both in Koskelo, 2005):

1. practical relevance of the construct
2. construct's connection to existing theory
3. theoretical novelty of the construct
4. proven use of the construct
5. proven, practical usability and usefulness
6. applicability in other environments.

As discussed in depth in Chapters 1 and 3, a need has recently emerged to better understand the nature of the RCF market, especially concerning the eventual interplay between the perspectives of the fibre and fuel markets. The main events in the business environment that have made this question very topical recently are a) the continuing growth in RCP utilisation, driven by strong growth in demand in geographical areas with a fibre deficit, b) the forecast saturation of RCP collection rates (increasing marginal costs for expanding collection and sorting), c) increasing investments in efficient W-t-E (industrial CHP, based on W-t-E), and d) political actions that promote the fuel use of wood in order to increase the proportion of renewable energy and to mitigate CO₂ emissions. The relevance of a construct that would provide a tool to analyse the behaviour of the composite RCF market is clear.

The proposed construct, an S/D model of the composite RCF market, is connected to existing theories in econometric analysis and ultimately to the very basic price theory of Alfred Marshall (1920), as explained in Chapter 4. As detailed in Chapter 6, the algebraic parameters used are based on the elasticities reported in previous economic literature, as well as on the market observations and comments of the expert panel participating in this study.

The theoretical novelty of the construct was discussed in Chapter 4. Previous models and econometric analysis have mainly focused on assessing the efficiency

of various policy instruments, typically aimed at increasing recycling. No pre-existing models that would help to understand the interplay of the fibre and fuel markets, simultaneously recognising the different physical forms of the material flows, were identified, thus indicating that the construct would be novel, even from the theoretical point of view. The original concepts of composite supply and demand as defined by Marshall (1920) are not adequate to consider a cascaded market encompassing different physical forms of material, as is the case with the various RCF-containing flows.

Kasanen et al. (1993, p. 253) emphasise the need for market-based validation of managerial constructions. A weak market test is met if any manager in financial responsibility for a business unit has been willing to apply the construction in his or her actual decision-making. A semi-strong market test is met if the construction has been widely adopted by companies, and a strong market test is met if it is proven that the business units applying the construct have systematically produced better financial results than those which are not using it. As the present construct, an S/D model of the composite RCF market, is not a management accounting construction, and as it is not meant for use at the firm level, but in an industry context, these criteria do not quite suit the purpose of assessing “proven use” of the construct. In the case of the present research, the main proof of use is in the form of the present research itself, and that the expert community that participated in the research in the form of the Delphi panel has accepted its usefulness. The proof of use is also discussed in section 7.2.3 where the research is evaluated from the point of view of scientific foresight.

The practical usability and usefulness of the construct was thoroughly discussed in Chapter 6. The construct – together with the applicable scientific foresight – is shown to provide useful indicative quantification of market development. It is also shown that the construct enables analysis of alternative scenarios of market development – the changes they would impose compared with the main scenario, and the conditions under which they are likely to emerge.

Kasanen’s criteria of applicability in other environments also refer to the firm context (Kasanen et al. 1993, pp. 252–253). They conclude that it is difficult to imagine a solution to a real-world management accounting problem that would not suit similar firms to the one(s) in which it was developed. In the case of this research, which does not handle the firm context, its applicability in other environments should perhaps be interpreted either as a reliability issue (are the results repeatable?), or as a question of analogy (are there other industries or raw material markets that would benefit from an analysis with the proposed construct?). According to the opinions of the Delphi panellists, the proposed composite model should be applicable to the wood market, for example, in which the main components are the log, pulpwood and fuel wood markets (including forest residues) and where the Q_{MAX} is formed by the annual growth that felling cannot exceed in the long run.

The question of reliability is discussed in section 7.4.

7.2.2 Practical criteria for the S/D model

The practical criteria for the S/D model of the composite RCF market were defined in section 3.8 as follows:

The model of the composite RCF market must be able to deliver practical utility in the form of better understanding of the interplay between the RCP market and the fuel market in a valid and reliable way.

Chapter 3.8 further used the pre-identified trends as examples of developments, the impacts of which should be better understood with the help of the model. The Delphi panel on the supply-demand behaviour of RCF added more trends to this list (Chapter 5). In Chapter 6 the model was used to study all the identified trends contributing either to the main scenario of the future development of the RCF market, or to its alternatives.

The remaining criteria of validity and reliability are discussed in Chapter 7.4.

7.2.3 Scientific foresight in the form of a Delphi panel

This section aims to evaluate the scientific merits and shortcomings of the foresight study that, together with the constructed S/D model, created the second main evidence base used in providing answers to this study's research questions. The Delphi process and the expert panel who contributed to the study also played a central role in iterating and refining the S/D model.

Evaluation of the results

According to Toivonen (2004) the typical challenge of future studies is to produce *relevant new information*. In this respect two important phenomena are to be considered:

1. Wholly new ideas about the future call for very specific capabilities and are rare. Often there is a lot of "rediscovering" or "institutional foresight" when experts start to repeat something that has been said in the expert community – even if they think it is genuine foresight. In the conceptual framework of this study, Figure 2.2, real foresight can be thought of identifying weak signals, and institutional foresight as describing strong prospective trends (Loveridge 2000, pp. 12–14, in Toivonen 2004).
2. The pace of change in phenomena whose existence has already been observed is often overestimated. However, experience has shown that the factors of inertia are highly important. This is why Godet suggests that a foresight project should always begin with a systematic recording of what has at least a good chance of remaining unchanged (Godet 1994, pp. 49–50, in Toivonen 2004).

The first phenomenon has prompted careful interpretation of the panel results. As the Delphi manager, I tried to dig behind the forecasts and arguments that appeared *institutional* and tried to spot the true *weak signals* from the communication with the panellists. In the Delphi panel of the present study, not very much wholly new information was produced, but a lot of forecasts and arguments were structured, thus contributing to a fairly balanced view of future development. Examples of new *weak signals*, or of improved understanding concerning *pre-known weak signals*, included the importance of the shadow supply schedule for RCP, the EtOH-from-waste concept, and perhaps a better understanding of the bio-refinery scenario in a pulp mill environment via its impacts on the price-elasticity of the pulp supply.

The second phenomenon raised by Toivonen is tackled in the present study by concentrating a lot on the numerical trends relevant to the development of RCF supply-demand behaviour. Thus the starting point for analysis has often been a factual numeric trend. This should have considerably helped in connecting all forecasts in some way to past development.

Kuusi (1999) makes a contribution to the epistemology of *anticipatory rationale*. He improves the distinction between *anticipatory rationale* and *irrational anticipations of the future* by underlining that scientific studies of the future should at minimum yield rational arguments – “Though it is not possible to present empirical truths concerning the future, it is possible to find truthful arguments concerning the future. A possible scientific endeavour may be to increase the validity of future relevant arguments.” (Kuusi 1999, p. 12). Table 7.1 makes an attempt to analyse in which areas of the study the Delphi process yielded relevant results. The table collects all the main forecasts that were produced by the panel. The fact that most trends were also supported by expert opinion categorising them as *strong prospective trends*, is not worrying as such. More of a concern is the fact that topic area D missed the trends altogether, and there were no weak signals at all associated with the topic area F. This might be a result of the sub-optimal planning of the Delphi panel, but is actually more related to the fact that the whole notion of a shadow supply schedule for RCP (as fuel) is new, and collecting truly valid data on it would require digging into the details of the marginal cost structures of operators in the field – which obviously is not that easy to achieve. It is also important to note that, besides these top line findings, very many of the detailed comments of the panellists contributed significantly both to the study and to the efforts to construct a model.

7. Conclusions

Table 7.1. Delphi study outputs by topic areas that are relevant for modelling market behaviour with the proposed S/D model.

Topic areas vs. classification of Delphi outputs	A. RCP demand	B. Substitute price	C. RCP supply	D. Shadow supply schedule	E. SRF demand	F. SRF supply
1. Strong prospective trends	++	++	++	-	+	+
2. Trends	-	++	-	-	-	-
3. Weak signals	+	++	+	+	+	-
	++= good coverage	+ = some coverage	- = not covered			

Methodological evaluation

In the following, a methodological evaluation of the Delphi study executed as part of this research is made in relation to the “eight pitfalls” as presented by Linstone (in Linstone and Turoff 2002, pp. 559–571).

1. Discounting the future

By *discounting the future* Linstone refers to the very basic human tendency to discount the possible events of a distant future. This easily leads to serious underestimations, as even quite small discount percentages yield large effects in the long run. The Delphi panel of the present study handled several price and volume trends in a time range of 10 years, which is a long enough period for the discounting effect to play a role. But RCP collection, for example, is in such a phase that its saturation is already at hand, and the risk of underestimation could thus be considered small. The development of SRF demand, on the other hand, is far more tricky. There was little numeric data available, and it is very tempting to believe that a recently experienced trend will continue.

2. Prediction urge

By *prediction urge* Linstone refers to the human tendency to give clear statements or predictions of the future, rather than speculations. A consensus of results is often viewed as more valuable than a divergence of views, despite the fact that the latter may prove to be more fruitful for a holistic understanding of a given development. The Delphi panel of this study ended up with a large divergence of opinion in only a few items, such as the views on how the substitute market will develop. This was also reflected in the alternative scenarios analysed with the constructed S/D model.

3. Simplification urge

Simplification urge to Linstone is analogical to the prediction urge. Just as humans tend to prefer certainty over uncertainty, they also tend to prefer simplicity over complexity. With interviews and especially with questionnaires, it is challenging to get the panellists to convey their true meaning and ideas. One just ticks “I agree”, even if you should make a comment to point out that the statement, though highly acceptable in general, does not apply in special circumstances. Most likely, the present Delphi panel also suffered from this phenomenon. The first round face-to-face interviews were in general more fruitful than the written responses received in the 2nd round questionnaire.

4. Illusory expertise

Illusory expertise refers to the general observation that experts are not necessarily the best forecasters. History is full of examples where experts have failed in their forecasts. In this respect the way how Kuusi (1999, p. 36) splits experts into scientists, decision-makers and synthesizers is valuable (c.f. Table 2.3). By definition, decision makers should know the real and perceived capacity limits, interests and capability limits, while synthesizers, on the other hand, should have an understanding of which of those are relevant in different situations. This study involves expert categorisation by Kuusi, thereby helping to mitigate *illusory expertise*.⁶⁵

5. Sloppy execution

Sloppy execution includes items that are influenced both by the analyst and by the participants. E.g. snowball sampling can produce panels of like-thinkers with little conflicts and creation of new knowledge. Also, the capabilities of the analyst are crucial. He/she should provide an atmosphere of a fruitful communication process – that time is not wasted on obvious aspects, that subtleties in responses are appreciated and understood. When the Delphi manager him/herself has a degree of expertise in the subject field (as I believe was the case also in this study), it should help to get the essential points across in the communication. On the other hand, the risk of involving like-thinkers may increase by such a connection.

6. Optimism-pessimism bias

Optimism-pessimism bias: Humans tend to be overoptimistic in their short-term and over-pessimistic in their long-term forecasts, although there is, of course, a big variety in individual characteristics. In the case of the present study, the time horizon was about ten years and the effects of an optimism-pessimism bias probably cannot be fully excluded.

⁶⁵ The obvious question remains: how does one *know* that a person really is a synthesizer?

7. Conclusions

7. Overselling

Overselling: It can be very problematic if the analyst has a strong agenda him/herself. Many times, people use Delphi for their organisational purposes. In the present case, the study was made with an industry context without the analyst having any company interests.

8. Deception

Deception: Delphi can be used for purposes of deception – like any other research. Honesty is required, as in all research.

The Delphi study executed as part of the present research probably suffers a little from a simplification urge and, as usual, the actual execution could have been better planned. Nevertheless, considering the rather focused topics and the carefully selected panel, the outcomes of the Delphi study can be considered as fulfilling their purpose, also from the methodological point of view.

7.3 Epistemic and practical utility of the research

7.3.1 Contribution to knowledge

The presented conceptual model of a multi-component cascade market is a special case or an additional development of the composite demand and supply of Marshall (1920). It is new and has proven useful in analysing a market for a factor of production, the total annual output of which is fixed.

The epistemic utility of the proposed multi-component cascade model is not limited to an analysis of the markets of RCF-containing waste flows. Analogically, the model can be used for similar factors of production. It is likely to be especially well suited for raw materials having inherently limited supply. A nice example would be the utilisation of wood raw material, the sustainable felling of which is limited by the annual growth of the forest stock. The use of felling split into mechanical, pulping and fuel uses. By using the concept of a shadow supply schedule, the model could compare how markets are likely to develop in relation to each other. This question has become topical for the wood markets partly for the same reasons as for RCF – the political push for renewable energy.

This study also operationalises an argument/trend type of Delphi process with a fairly focused task of obtaining foresight of quite a specific nature. The study adds further depth to the foresight by complementing it with a quantifiable market model. This can be considered an example of the often called-for approach that truly combines qualitative and quantitative information in normative research (Eisenhardt 1989, p. 538).

As a result of the above-mentioned, we can conclude the answer to the remaining research question:

Q9: Are there analogical problems where the combination of the proposed composite market model and scientific foresight are applicable and useful?

The answer is *yes*, such examples can be found, among other factors of production with multiple uses and physical forms, especially when the total annual output of that factor is fixed.

7.3.2 Practical contribution

The research has provided in-depth understanding of several topical questions concerning the RCF market. While the limitations both in the scope of the Delphi study and in the available data forced quite a few rather vague assumptions to be made in the quantifications, the model was still demonstrated to be useful for meaningful quantifications and the resulting information should be useful for practitioners in both the RCF-based paper industry and the waste management sector. In fact, the weaknesses in the reported work provide excellent opportunities for future research in the field.

7.4 Validity and reliability of the research

The validity and reliability of research are important aspects in a critical evaluation of research. They are considered to be of special importance in qualitative research (Koskelo 2005, p. 214). Validity can be divided into internal validity, external validity and construct validity. Internal validity means validity of the reasoning and causal relationships within the research setting itself. External validity refers to the applicability of results outside the studied cases. Construct validity means that you really measure what is targeted and “emphasizes the establishment of proper operational measures of the concepts being studied” (Lanning 2001, p. 153).

7.4.1 Internal validity

Internal validity is related to causal relationships in exploratory studies (Yin 1989, p. 42, in Koskelo, 2005). The main purpose of this study was to qualitatively understand the impacts of W-t-E in the supply and demand behaviour of recycled fibre. Still, this study includes identifying causal relationships in the form of the quantifications of the constructed S/D model. In quantification the researcher has ensured full traceability of all numeric extrapolations and the deduced facts. Reference has been made to all sources of assumptions.

7.4.2 External validity

This research is not a case study by nature. Though it is crafted with a constructive research approach, it does not investigate a firm or case context, but aims at

gaining findings at the level of the whole industry. Therefore, the question of external validity is not relevant for this research. The applicability of the constructed model to other industries and problem settings was pointed out under the discussion of epistemic utility in section 7.3.1.

7.4.3 Construct validity

In terms of construct validity, Yin offers the following suggestions to the researcher (Yin 1984, pp. 41–42, in Lanning 2001):

1. Choose cases that most evidently have something to offer regarding the research problem.
2. Demonstrate that your way of measurement and the measures used are clearly connected with the phenomena studied.
3. Use multiple sources of evidence.
4. Establish a chain of evidence.
5. Have case study reports reviewed by key informants.

As mentioned before, this research does not employ cases, in their traditional sense. However, it employs narratives, or detailed examples of interesting phenomena relevant to the research issue. These narratives serve the purpose of illustrating qualitative developments, important for a holistic understanding of the topic, and are consequently in the construction task.

The measurement and measures used in this study are mainly direct measures of the phenomena studied. Therefore, the second point by Yin is not of particular concern in this study. Perhaps the supply schedules S_{RCPF} and S_{SRF} are examples where the used assumptions are not based on direct measures of the studied phenomena. In those cases this research mainly relies on interviews of industry experts.

This study uses multiple sources of evidence: literature from several fields of science, interviews, the Delphi panel – a scientific method of foresight, and finally algebraic modelling of supply and demand schedules.

The reporting of this research has aimed at as complete a chain of evidence as possible. Yin (1989, p. 102, in Koskelo 2005) points out that the reader should be able to follow the research and its different phases, “to follow the derivation of any evidence from initial research question to ultimate case study conclusions”. The central qualitative part of the study, the Delphi panel, is rigorously documented and its main intermediary reports are appended to this thesis. Also, all face-to-face interviews have been documented in written memos that the interviewees have accepted and/or corrected. In particular, the research questions have been formed plausibly, so it is possible to get clear answers to them; the answers were summarised in section 7.1.

Yin's fifth point is again not very relevant in this research, as it is not based on traditional case studies. On the other hand, a central feature in the Delphi process is formulating information, argumentation concerning future developments and the

like, and distributing it to all participants in several rounds to ensure communication and a common understanding of the statements within the ranks of the panellists.

7.4.4 Reliability

The reliability of research means that it is repeatable. To qualify as reliable, research has to be such that another researcher would get the same results and come to the same conclusions independent of the original research. This is usually a difficult challenge for qualitative research, as the same research setting can seldom be exactly reproduced. For qualitative research, ensuring and demonstrating that the used data generation and analysis have not only been appropriate to the research questions, but also thorough, careful, honest and accurate, becomes very important (Lanning 2001, p. 157).

This research combines qualitative and quantitative methods. The main challenge of reliability in this study relates to the Delphi process, the carrying out of which has been evaluated from the methodological perspective in section 7.2.3.

In the quantification of the market model, the author was, at certain points, short of data and the quantification was based on interviews of single experts and sheer deduction. One particular uncertainty is related to the reliability of the chosen price elasticities. They are based on reported elasticities from past works in the field of econometric analysis, but, in fact, there might be limitations in the studied data that lead to a failure to recognise the global nature of the market – or some of the important firm-level constraints.

Thus it is not likely that, later, another researcher to which other data and multiple sources of evidence are available, will come to exactly the same quantified results. Even some of the conclusions related to market scenarios might change. Thus, concerning the quantification attempt of the model, there is little proof of its reliability. This can hardly be considered to jeopardize the overall qualitative findings and merits of the study, however.

8. Discussion

8.1 Summary of the study

This study has focused on investigating the nature of the composite RCF market, consisting of its use as fibre raw material (traded as various grades of RCP), use among quality-controlled fuel streams (typically traded as SRF) and disposal among various MSW streams. A new construct, a model of the composite RCF market was developed based on price theory, the literature on econometric analysis and expert knowledge. Scientific foresight on market development was gathered by means of a Delphi panel. The foresight and the model were utilised together for generation of quantified market forecasts and in order to test and refine the practical functioning of the generated model.

The RCP market was found to be a global market, where the market price is set by the overseas export market developments, rather than by developments on the European markets. Previous econometric analysis has mainly failed to recognise this. The study was not able to produce a credible forecast of the RCP price development over the next decade, but provided a model to use in studying related phenomena. Based on the model and parameters used, it appears that the RCP utilisation rate will not grow anymore in Europe by 2020, but might actually turn to a decline under price pressure from overseas export markets with high paying capacity.

On the other hand, it seems clear that a fuel market for efficient W-t-E is rapidly developing in Europe, thanks to investments in modern boiler technology, advantageously located at RCP-utilising paper mills. This solid recovered fuel market will provide an alternative sink for RCP (primarily for RCP of poor quality) that effectively removes the lowest valleys in the price cycle. Furthermore, advanced technical concepts are under development that might in European political conditions push the paying capability of W-t-E for RCF-containing flows so high that even direct bleed between the fibre and fuel markets might emerge by 2020. The main conditions contributing to such bleed would be low RCP prices (e.g. due to low factor costs of virgin fibre production or due to weak development of export demand) and political decisions to support advanced W-t-E concepts or biomass-based energy in general.

8.2 Managerial lessons of the study for the P&P industry

A few items of strategic importance for the P&P industry can be identified based on the present study. As a practitioner in P&P, I have a personal interest in bringing this viewpoint up, rather than the perspective of the energy or waste management sectors.

8.2.1 Likely emergence of fuel market for waste paper

The main scenario 2020 presented in Chapter 6 of this report indicates that a direct bleed between the RCF markets as fibre and as fuel might well emerge, even at such high price levels for mixed waste paper as 150 €/t. Combined with an analysis of alternative scenarios that folded out based on the expert panellists' viewpoints, ***this suggests that the P&P industry should prepare itself for a future where recycled fibre costs almost permanently stick to rather high levels.*** This finding emphasises the importance of vertical integration and strategies of acquiring control over the waste flows containing RCF – whether they be in fuel or RCP form. New opportunities for optimising the use of discarded paper content in wastes is only available for those in control of the waste flows.

8.2.2 New concept opportunities for paper mills

This study has outlined a few potential W-t-E related production concepts for RCF-based papermaking. A summary of their modelled competitiveness has been presented in Chapter 3.4. Their potential importance and impact is related to their ability to mitigate, or turn to the investing company's competitive advantage, the rising energy cost, tightening supply of recovered paper and the emergence of a fuel market for waste paper. There appears to be much wisdom in the old proverb: "If you can't beat them, join them!"

The only of the concepts discussed in this study that is already applied by the industry on a large scale is the "Urban Mill, alt.1", that simply introduces a W-t-E CHP power plant adjacent to an RCF-based paper mill such that it is dimensioned to fit the energy needs of the paper mill. As paper mills happen to be significant consumers of energy, this often leads to quite large and thus highly competitive units (> 100 MW) without major reliance on outside buyers for heat. For RCF-utilising papermakers there is no reason to hold back from this development. The magnitude of available benefit, as discussed in this study, is so large that staying out of the competition may prove very dangerous in the long run. The counter argument might be that in the not so distant future the market price for collection and treatment of wastes might go to zero or even turn negative (i.e. waste management bill of commerce and households would turn into income – interview of Hietanen L. 2009). Still, according to the modelling used in this study, this concept might well remain profitable.

The other concepts discussed in this study are still mainly under the phase of industrial piloting. All of them have already been tested for variations in mass balance and both operating and investment costs can be estimated. While all of these concepts appear promising, they have not yet passed their market test and it is impossible to reliably estimate if they will ever be implemented on an industrial scale or not. The conclusion for managers in the P&P industry is clear, though: there are opportunities for active players to study and work on. The passive approach of just continuing business as usual is likely to lead to descent and loss of market positions.

It is worthwhile to note that the simple combination of W-t-E power plant and the RCF-based paper mill ("Urban Mill, alt. 1") forms a perfect platform for further value-added developments – both in terms of optimising the outputs from W-t-E (e.g. "Urban Ethanol"-concepts) as well as stretching the limits of waste paper processing (as in "Urban Mill, alt 2.").

There is yet another aspect to the envisioned development: by presenting sustainable, value-added solutions to waste management and utilisation of secondary raw materials with unique process synergies, the paper industry might be able to get a hold of a significant resource base that is under the political control of municipalities. For instance the Urban Ethanol concept is likely to receive high political acceptance.

Also from the theoretical perspective, in accordance with the Resource-Based View (RBV, see e.g. Wernerfelt 1984 and Peteraf 1993), the established players in RCF-based papermaking carry inimitable, largely structural, advantage to the more regular waste management players and even utility companies in the form of the repeatedly mentioned synergies between W-t-E and papermaking. RBV also recognises a first-mover advantage as one barrier to imitation of strategic resources. This is especially true in the case of exploiting W-t-E by a paper mill: utilising wastes often involves long-term contractual commitments that lock-out the regional competition.

8.2.3 Systemic changes in managing discarded-paper-containing waste flows

This report started by presenting the basic characteristics of the paper collection and recycle system in Figure 1.2. Considering the results of the study, the following systemic changes in managing discarded-paper-containing waste flows could be proposed or predicted (see Figure 8.1):

- No discarded-paper-containing MSW or CIW ends up directly in disposal anymore.
- RCF-utilising paper mills will commonly be equipped with RDF preparation and utilisation facilities.
- Treatment of discarded-paper-containing MSW and CIW flows takes place in connection with RCF-utilising paper mills.

- All rejects from collection, sorting and processing of RCP will be handled in connection with RCF-utilising paper mills.
- Separate collection systems for RCP will stay as today, perhaps with the exception of certain large CIW producers and flows, where various fibrous and non-fibrous packaging wastes could in future be collected mixed together.

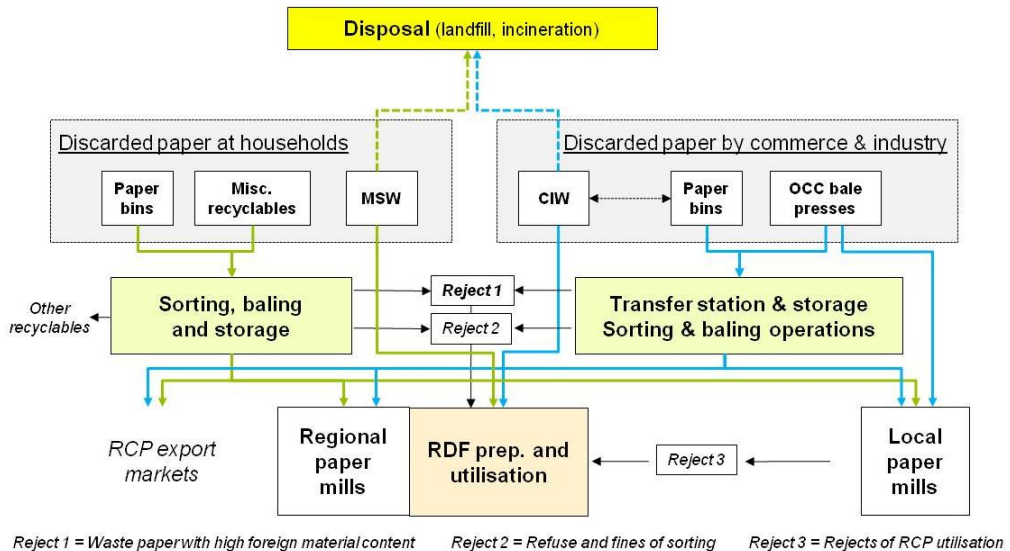

Figure 8.1. Possible new state of the paper collection and recycle system (c.f. Figure 1.2).

8.3 Issues for future research

In order to fully utilise the proposed composite S/D model of the RCF market there is a need for more data and more detailed research on several fronts. These include e.g. the demand and supply schedules for SRF and similar flows, the supply schedule of RCP at such an accuracy that its shadow supply as fuel can be reliably understood, and grade-specific analysis of RCP collection and utilisation volumes covering at least Europe, North America and the major Asian consuming countries. Together these would pave the way for more detailed econometric analysis and defining grade-specific supply and demand schedules. A fully operational, composite model of the RCF market that cascades different RCP grades, recognises substitution effects between them and, using accurate data, explains and predicts the developments in the composite market appears a possible goal, but will require large amounts of future research. It is important that such research fully considers the global nature of the RCP market.

8. Discussion

There are also no limitations preventing the cascaded model of the RCF market from including other competing end uses for the RCF content found in waste streams. For example, the market for RCF as a raw material for cellulosic insulation material could also be included.

Future research on the composite RCF market, or analogically e.g. on the composite wood markets, could provide important information on the economic behaviour of such factor markets whose supply is somehow fundamentally limited, but might be utilised in different forms by different markets.

References

Regular interviews

Ervasti, Ilpo. Pöyry Forest Industry Consulting in 2009, later private consultant. Interviews on 15.9.2009 and 13.12.2010.

Hietanen, Lassi. Senior specialist, Lassila and Tikanoja Oyj. Interviews on 4.8.2009, 29.3.2011, 24.5.2011.

Kuusi, Osmo. Research professor, VATT (Government Institute for Economic Research in Finland). Interviews on 3.2.2010 and 15.9.2010; Completing email correspondence on 19.1.2010 and 12.5.2011.

Sipilä, Esa. Consultant, Pöyry Forest Industry Consulting, Interviews on 19.4.2010, 29.3.2011 and 24.5.2011.

Sipilä, Kai. Vice President, Professor, VTT – Technical Research Centre of Finland. Interviews on 7.12. 2009, 29.3.2011 and 3.6.2011.

Delphi first round interviews

Diesen, Magnus. Specialist, Aalto University, Department of forest products technology (ex. SVP, Corporate Development and Investments, StoraEnso Oyj). Interview on 24.2.2010.

Ervasti, Ilpo. Private consultant and specialist in RCP. Interview on 7.4.2010.

Glorius, Thomas. Stoffstrom- und projektmanagement, Remondis GmbH, Interview on 31.5.2010.

Hellman, Jarno. Managing director, Suomen Keräystuote Oy, Director Lassila and Tikanoja environmental services, Interview on 9.4.2010.

Hietanen, Lassi. Leading specialist, environmental services, Lassila and Tikanoja Oyj. Interview on 14.4.2010.

Hänninen, Pauli. Executive VP, UPM-Kymmene Oyj, Interview on 13.9.2010.

Karlsson, Markku. Senior VP Technology, UPM-Kymmene Oyj, Interview on 31.8.2010.

Kuusi, Osmo. Research professor, VATT (Government Institute for Economic Research in Finland), Interview on 11.5.2010.

Oikarinen, Seppo. Manager Business Development, RCP Resource Management, UPM-Kymmene, Interview on 4.5.2010.

Ous, Herdis. Manager Business Intelligence, Marketing and Controlling Recovered Paper, StoraEnso, Interview on 19.5.2010.

Pehu-Lehtonen, Kaija. Senior VP Business development, Oy Metsä-Botnia Ab, Interview on 9.6.2010.

Sipilä, Esa. Consultant, Pöyry Forest Industry Consulting, Interview on 19.4.2010.

Sipilä, Kai. Vice President, Professor, VTT – Technical Research Centre of Finland. Interview on 19.4.2010.

Suhonen, Timo. VP, Pöyry Management Consulting, Interview on 26.4.2010.

Wurster, Hartmut. Executive VP, UPM-Kymmene Oyj, Interview on 19.5.2010.

References to legislation and policy statements

1999/31/EC. European Council Directive of 26 April 1999 on the landfill of waste. Official Journal L 182 , 16/07/1999. Pp. 1–19.

2000/76/EC. European Council Directive of 4 December 2000 on the incineration of waste (WID); Official Journal L 332, 28/12/2000. Pp. 1–21.

2008/98/EC. European Council Directive on waste. (Waste Framework Directive (WFD); Official Journal L 312/3, 22/11/2008. Pp. 1–28.

2009/28/EC. European Council Directive of June 5 2009 on the promotion of the use of energy from renewable sources in European Union (EU). Official Journal L140/16, 05/06/2009 (RED).

European Commission 2005. Communication from the Commission – Biomass action plan {SEC(2005) 1573}. CELEX number: 52005DC0628.

European Commission 2011. National Renewable Energy Action Plans. http://ec.europa.eu/energy/renewables/transparency_platform/action_plan_en.htm (retrieved 27.4.2012).

European Commission, Cordis 2010. FIBREETHOH. Bioethanol from paper fibres separated from solid waste, MSW. Demonstration project webpage in EC CORDIS-system. Record number: 94485. Last updated on (QVD): 12.5.2010. http://cordis.europa.eu/projects/rcn/94485_en.html (retrieved 29.4.2012).

European Council, Public Health Committee 2007. Committee of experts on materials coming into contact with food. Policy statement concerning paper and board materials and articles intended to come into contact with food-stuffs. 11.12.2007.

US EPA 2011. Renewable fuel Standard. US Environmental Protection Agency (EPA). <http://www.epa.gov/otaq/fuels/renewablefuels/index.htm>.

Document references

AF&PA 2007. AF&PA Community Survey Executive Summary. American Forest and Paper Association, June 2008.

Anderson, R. C. and Spiegelman, R. D. 1977. Tax policy and secondary material use. *Journal of environmental economics and Management*, Vol. 4, pp. 68–82.

Anon. 2003. Rich on fibre: Fiskeby Board. *Pack Marknaden* No. 5, May 2003, p. 13.

Beckmann, M., Pohl, M. and Ncube, S. 2007. Charakterisierung von Ersatzbrennstoffen hinsichtlich brennstofftechnischer Eigenschaften. *Energie aus Abfall – Band 3*. Neuruppin: TK Verlag Karl-Thomé-Kozmiensky, pp. 203–218.

Berglund, C. 2003. Economic efficiency in waste management and recycling. Doctoral thesis, Luleå University of Technology, 2003:01.

Berglund, C. 2004. Spatial cost efficiency in waste paper handling: the case of corrugated board in Sweden. *Res., conservation and recycling*, Vol. 42, pp. 367–387.

Berglund, C. and Söderholm, P. 2003. An econometric analysis of global waste paper recovery and utilization. *Env. and resource economics*, Vol. 26, pp. 429–456.

Bienert, C. and Hanecker, E. 2003. INGEDE Project 76 01 PTS: Utilisation of deinking mill residues in the year 2000. 12th INGEDE Symposium, January 2003.

Brems, H. 1975. Marshall on mathematics. *Journal of Law and Economics* (University of Chicago Press), Vol. 18, No. 2, pp. 583–585.

Bülow, C. 2005. Economic aspects of fibre usage. *Wochenblatt für Papierfabrikation*, Vol. 133, No. 8, pp. 423–424, 426, 429, 430–433.

- Bushaw, D. W. and Clower R. W. 1957. Introduction to mathematical economics. Homewood Illinois, Richard D. Irwin Inc.
- Cao, Z. 2006. Recovered Paper – China Cast a Wide Supply Net. RISI Asian Pulp and Paper Outlook Conference 24.–25.4.2006.
- Chiang, A. C. and Wainwright K. 2005. Fundamental Methods of Mathematical Economics. McGraw-Hill Irwin.
- Clark, B. 1998. Political economy: a comparative approach. Westport, CT. Praeger Publishers.
- CEPI 2010. Key statistics 2009 – European Pulp and Paper Industry, Confederation of European Paper Industries, June 2010.
- Dahlbo, H., Laukka, J., Myllymaa, T., Koskela, S., Tenhunen, J., Seppälä, J., Jouttijärvi, T. and Melanen, M. 2005. Waste management options for discarded newspaper in the Helsinki Metropolitan Area. Finnish Environment 752. Finnish Environment Institute, Helsinki.
- Davies, D. 2002. Recovered Paper Standard EN643: Making it Work – Collection and separation options. Environmental Services Association Workshop. London, July 2002.
- Deadman, D. and Turner, R. K. 1981. Comment: Modeling the supply of wastepaper. Journal of Environmental Economics and Management, Vol. 8, pp. 100–103.
- Debreu, G. 1987. Mathematical economics. The New Palgrave: a dictionary of economics, Vol. 3.
- Diesen, M. 1998a. Economy of scale. In: Economics of the Pulp and Paper Industry. Diesen, M. (Ed.). Fapet Oy, Helsinki. Pp. 141–149.
- Diesen, M. 1998b. Investment decision. In: Economics of the Pulp and Paper Industry, Diesen, M. (Ed.). Fapet Oy, Helsinki. P. 129.
- ECE 1999. Iron and steel scrap: its significance and influence on further developments in the iron and steel industries. 8th update. ECE Steel series, United Nations and Economic Commission for Europe.
- Edgren, J. A. and Moreland, K. W. 1989. An Econometric Analysis of Paper and Wastepaper Markets. Resources and Energy, Vol. 11, No. 3, pp. 299–319.

- Eisenhardt, K. 1989. Building theories from case study research. *Academy of Management Review*, Vol. 14, No. 4, pp. 532–550.
- Enerkem 2009. Enerkem Greenfield Alberta Biofuels Awarded Permit to Build World's First Commercial Municipal Waste-to-Biofuels Facility. Press release 20.5.2009. <http://www.enerkem.com> (retrieved 29.4.2012).
- ERFO 2009. SRF Facts and figures. 18.5.2009. European Recovered Fuel Organisation. <http://www.erfo.com> (retrieved 29.5.2011).
- Ervasti, I. 2006a. Recovered Paper – Limits of Paper Recycling. *Pulp and Paper (Bulgaria)* 36:1.
- Ervasti, I. 2006b. Keräyspaperin merkitys paperi- ja kartonkiteollisuuden raaka-aineena kasvaa jatkuvasti. *Metsänhoitaja Magazine*, 2006:1, Finland.
- Ervasti, I. 2007. A Global View – and how many times can paper be recycled. *Letsrecycle.com*, 7.7.2003. <http://www.letsrecycle.com> (retrieved 27.4.2012).
- European Recovered Paper Council 2010. European declaration of paper recycling 2006–2010, Monitoring report 2009.
- Faul, A. 2009. Graphic paper recycling – markets and quality requirements. In: COST E48 Final Conference. Munich, May 2009.
- Fiberight 2012. Converting Non-Recycled Organic Trash into Fuel Grade Cellulosic Ethanol. Process description on web pages. http://www.fiberight.com/press/fiberight_process.pdf (29.4.2012).
- Flyvbjerg, B. 2011. Case Study. In: *The Sage Handbook of Qualitative Research*. 4th Edition. Sage, Thousand Oaks, CA, USA.
- Gill, G. and Lahiri, K. An econometric model of wastepaper recycling in the USA. *Resources Policy*. December 1980, pp. 320–325.
- Götz, B. and Pfaff, D. 2003. Origin and disposal of waste from pulp and paper industry: results of a survey. *Wochenblatt für Papierfabrikation*, Vol. 131, No. 17, mid Sept. 2003, pp. 1026, 1028–1029.
- Hamm, U., Göttching, L. and Pakarinen, H. (Ed.) 2000. Final fate of waste from recovered paper processing and non-recycled paper products. *Recycled fibre and deinking. FAPET*, Espoo, Finland. Pp. 507–591.

- Hashem, P. M. 1987. *Econometrics. The New Palgrave: a dictionary of economics*, Vol. 2.
- Hayek, F. 1945. The use of knowledge in society. *American Economic Review*, Vol. 35, No. 4, pp. 519–530.
- Heilbroner, R. 1999. The end of the worldly philosophy – interview with Robert Heilbroner. *Challenge Magazine*, May–June 1999.
- Hietanen, J. 2009. Teknistaloudellinen tarkastelu kierrätys- ja jätekuidun määrästä, laadusta sekä muuttuneesta käyttötilanteesta Suomessa, Masters Thesis, Helsinki University of Technology, 2009. (In Finnish.)
- Holik, H., Göttching L. and Pakarinen, H. (ed.). 2000. Unit operations and equipment in recycled fiber processing. *Recycled fibre and deinking. FAPET*, Espoo, Finland. 2000, pp. 91–209.
- Holmström, J., Ketokivi, M. and Hameri, A.-P. 2009. Bridging practice and theory: a design science approach. *Decision Sciences*, Vol. 40, No. 1, pp. 65–87.
- Huhtala, A. and Samakovlis, E. 2002. Does international harmonization of environmental policy instruments make economic sense? The case of paper recycling in Europe. *Environmental and Resource Economics*, Vol. 21, pp. 261–286.
- Huttunen, A. 1996. Changes in waste paper prices can be explained and anticipated. *Paperi ja Puu*, Vol. 78, No. 8, pp. 436–439.
- IPCC 2006. Waste generation, composition and management data. In 2006 IPCC guidelines for national greenhouse gas inventories. Intergovernmental Panel on Climate Change.
- Juva, A. 2008. Liikenteen biopolttoaineet. BIOREFINE-seminar of TEKES, 23.9.2008.
- Järvenpää, E. and Kosonen, K. 1997. Johdatus tutkimusmenetelmiin ja tutkimuksen tekemiseen. Teknillinen korkeakoulu, Tuotantotalouden osasto, Teaching materials, 1/1997, Libella Painopalvelu Oy, Otaniemi. (In Finnish.)
- Karjalainen, T., Asikainen, A., Ilavsky, J., Zamboni, R., Hotari, K.-E. and Röser, D. 2004. Estimation of energy wood potential in Europe. Working Papers of the Finnish Forest Research Institute.

- Kasanen, E., Lukka, K. and Siitonen, A. 1993. The constructive approach in management accounting research. *Journal of Management Accounting Research*, Vol. 5, Fall 1999, pp. 243–264.
- Kersten, A., Hamm, U., Putz, H.-J. and Schabel, S. 2011. Zur Diskussion um die Migration von Mineralöl in Lebensmittel und das Altpapier-Recycling. *Wochenblatt für Papierfabrikation*, 1/2011, pp. 14–21.
- Kiel, J. 2007. Torrefaction for biomass upgrading into commodity fuels. IEA Bioenergy Task 32 workshop “Fuel storage, handling and preparation and system analysis for biomass combustion technologies”, Berlin, 7.5.2007.
- Koepnick, M. 1995. Mini mill, major impact. *PIMA Magazine*, January 1995.
- Koskelo, T. 2005. A method for strategic technical life cycle management of real estates. HUT / Laboratory of Industrial Management. Doctoral dissertation series 2005/1.
- Kuusi, O. 1999. Expertise in the future use of generic technologies – Epistemic and methodological considerations concerning Delphi studies. VATT-Research Reports 59. VATT, Helsinki.
- Kärnä, A., Engström, J., Kutinlahti, T. and Pajula, T. 1994. Life cycle analysis of newsprint: European Scenarios. *Paperi ja Puu*, Vol. 76, No. 4, pp. 232–237.
- Landsburg, S. E. 2008. *Price theory*. Thomson South-Western, Ohio, US. Pp. 475–498.
- Lanning, H. 2001. Planning and implementing change in organisations. HUT/IEM, 16.11.2001.
- Lee, M and Ma, H.-O. 2001. Substitution possibility between unpriced pulp and wastepaper in the U.S. paper and paperboard industry, Vol. 18, pp. 251–273.
- Lindstedt, J. 2010. Swedish experience – from demo to production scale of cellulose based ethanol. First international conference on lignocellulosic ethanol. Copenhagen, 13.–15.10.2010.
- Linstone, H. A. and Turoff, M. (Ed.) 2002. *The Delphi Method, Techniques and Applications*.
- Lundmark, R. 2001. Choice of location for investments in the european paper industry: the impact of waste paper. *Res., conservation and recy*, Vol. 33, pp. 167–180.

- Lundmark, R. and Söderholm, P. 2003. Structural changes in Swedish wastepaper demand: a variable cost function approach. *Journal of Forest Economics*, Vol. 9, pp. 41–63.
- Makkonen, P. and Hotta, A. 2002. Experiences of RDF fluid bed combustion and gasification, emissions and fuel quality aspects. Power production from waste and biomass IV – Advanced concepts and technologies. VTT Symposium 222. Pp. 185–209.
- Mankiw, G. N and Taylor, M. P. 2006. *Economics*. Thomson Learning, London.
- Mantau, U. et al. 2010. EUwood – Real potential for changes in growth and use of EU forests. Final report. Hamburg/Germany, June 2010.
- Marshall, A. 1920. *Principles of economics*. MacMillan and co., London.
- Menges, W. 1992. Pilot plant for the development of a new secondary stock preparation stage for recyclable composites in the Redenfelden mill of PWA IP GmbH. *Wochenblatt für Papierfabrikation*, Vol. 120, No. 22, Nov. 1992, pp. 911–914.
- Menke, L. 2009. Instead of disposal, create energy – Palm paper mill in Wörth. *Voith Paper's Twogether*, Vol. 28, pp. 4–11.
- Moore, W. 2003. Recovered paper quality declines as industry pushes higher use rate. *Pulp Paper*, Vol. 77, No. 10, Oct. 2003, pp. 42–44, p. 46.
- Mäkipaja, L. 1998. Stock preparation system for liquid packaging board with integral rejects cleaning and fibre recovery. The second EcoPaperTech. An International conference on economy and ecology in papermaking technology, Helsinki, Finland, 1.–5.6.1998. KCL Finnish Pulp and Paper Research Institute, pp. 11–31.
- Nestor, D. V. 1992. Partial static equilibrium model of newsprint recycling. *Applied economics*, Vol. 24, pp. 411–417.
- Parfitt, J. 2009. Taking out the rubbish: Municipal waste composition, trends and futures. *MSW trends, futures 27.4.2009*. Resource Futures Ltd.
- Parfitt, J. 2010. Lifting the lid: the first 140 years of the UK dustbin. *Resource Sep-Oct 2010*. Resource Futures.
- Peteraf, M. A. 1993. The cornerstones of competitive advantage: a resource-based view. *Strategic management journal*, Vol. 14, No. 3, pp. 179–191.

- Prins, K. 2010. Policy options for more wood: Strategies and recommendations for a sustainable wood mobilisation.. In: EUwood – Final report, Hamburg, Germany, June 2010. Pp. 108–126.
- Pöyry Forest Industry Consulting 2008. World paper outlook up to 2025. Vantaa, Finland.
- Pöyry Forest Industry Consulting 2009. World fibre outlook up to 2025. Vantaa, Finland.
- Pöyry SmartTerminal. Multi-client database of world pulp and paper mills and their investment history. Data retrieved in 2009–2011.
- Ranta, L. 2010. Fibre ETOH – lignocellulosic waste fibres to ethanol. First international conference on lignocellulosic ethanol. Copenhagen, 13.–15.10.2010.
- Ristola, J. 1973. Raskaan polttoöljyn palaminen pyörrekerroksessa. Masters Thesis, Tampere University of Technology, Department of Mechanical Engineering. Tampere, Finland.
- Ristola, P. 1999. Urban Mill: Papermaking Capacity Integrated To Local Infrastructure In: Optimal Utilization of Wood Fibre: Energy and Paper Products, The Second Biennial Johan Gullichsen Colloquium, The Finnish Paper Engineers' Association, Helsinki. Pp. 205–215.
- Ristola, P. 2002. New approach to recycling and waste-to-energy in paper production, Urban Mill. Power production from waste and biomass IV – Advanced concepts and technologies. VTT Symposium series 222, pp. 103–111.
- Ristola P. 2004a. Fibre recovery from pre-treated dry wastes. Yearbook of STREAMS technology program. TEKES, Finland, 2004 (2), pp. 151–155.
- Ristola, P. 2004b. RCF rejects disposal solutions and the effect of landfill closure and new chemical EU legislation. Unpublished research report at HUT, Laboratory of Paper Technology. Helsinki University of Technology.
- Ristola, P. and Karlsson, M. 2000. Urban Mill: Optimising synergies with environmental factors. ATIP 2000, Technical Conference, 18.10.2000. Bordeaux, France.
- Ristola, P. and Mirata, M. 2007. Industrial symbiosis for more sustainable, localised industrial systems. Progress in Industrial Ecology – An International Journal 3/4 (4), pp. 184–204.

- Samakovlis, E. 2003. The relationship between waste paper and other inputs in the Swedish paper industry. *Environmental and Resource Economics*, Vol. 25, pp. 191–212.
- Samakovlis, E. 2004. Revaluing the hierarchy of paper recycling. *Energy Economics*, Vol. 26, pp. 101–122.
- Schultz, J. 1995. The makings of a mini-mill. Paperboard packaging, February 1995, pp. 16–19.
- SEKAB 2012. SEKAB E-Technology AB Ends its Operational Commitment in the Ethanol Pilot. Press release 9.12.2011. <http://www.sekab.com/press> (retrieved 29.4.2012).
- Sillman, J. 2009. History and development of Paper and Board recycling in Europe. In: *Cost Action E48 – Final Conference. The Limits of Paper Recycling*. München, 6.5.2009.
- Sipilä, E. 2010a. Uusien jäteperäisten biopolttoaineiden luomat liiketoimintamahdollisuudet metsäteollisuudessa. Masters Thesis, Helsinki University of Technology. (In Finnish.)
- Sipilä, E. 2010b. The economics of the urban CHPF concept. First international conference on lignocellulosic ethanol. 13.–15.10.2010, Copenhagen.
- Sipilä, E., Vehlow J., Vainikka P., Wilén C and Sipilä K. 2009. Market potential of high efficiency CHP and waste based ethanol in European pulp and paper industry. VTT Research notes 2500. VTT, Espoo, Finland.
- Solow, R. M. 1988. The wide, wide world of wealth. *Review of The New Palgrave, a dictionary of economics*. New York Times, 20.3.1988.
- Spieß, W. and Renner, K. 2004. Verbesserung der Effizienz einer AP-Sortierung oder – Wie wird man Herr der Stickys. *Wochenblatt für Papierfabrikation*, Vol. 132, No. 17, mid Sept. 2004, pp. 1002–1006.
- Statistics Finland 2011. Polttoaineluokitus ja päästökertoimet 2011. http://tilasto.keskus.fi/tup/khkinv/khkaasut_polttoaineluokitus.html (retrieved 29.4.2012).
- Stawicki, B. and Read, B. (Eds.) 2010. COST Action E48 – The future of paper recycling in Europe: opportunities and limitations. COST Action E48 Final report.
- Steierer, F. 2010. Energy use. In: *EUwood – Final report*. Hamburg, Germany, June 2010. Pp. 43–55.

- Stichting Bos en Hout. 2000. EU energy policy impacts on the forest – based industries, Summary report. A consulting report for EU Commission DG Enterprise and a consortium of industry associations.
- Stigler, G. 1987. The theory of price. MacMillan publishing co. New York. Pp. 248–257.
- Straetman, B. 2010. SRF market views in Europe. Solid Recovered Fuels – A Sustainable Option for Europe; International Workshop 31.5.2010.
- Tapio, P. 2002. The Limits to Traffic Volume Growth: The Content and Procedure of Administrative Futures Studies on Finnish Transport CO2 Policy. Acta Futura Fennica 8.
- Thalheimer, J. and Haas, A. 2008. Modern combined cycle cogeneration power plant in combination with a residue fired steam generator for the Palm paper mill in Wörth. Pup&Paper Technology Magazine. [http://www.eproplan.de/fileadmin/archiv/seiten/Aktuelles/Pulp %26 Paper Technology.pdf](http://www.eproplan.de/fileadmin/archiv/seiten/Aktuelles/Pulp_%26_Paper_Technology.pdf) (27.4.2012).
- Thornton, S. 2009. “Karl Popper” in The Stanford Encyclopedia of Philosophy (Summer 2009 Edition). Zalta, E. N. (Ed.). <http://plato.stanford.edu/archives/sum2009/entries/popper> (27.4.2012).
- Toivonen, M. 2004. Expertise As Business. Long-term development and future prospects of knowledge-intensive business services (KIBS). Helsinki University of Technology, Laboratory of Industrial Management, Doctoral dissertation series 2004/2.
- UPM 2011. Biofore FAQ on web pages. <http://www.upmbiofore.com/> (retrieved 24.2.2011).
- US EPA 2010. Municipal Solid Waste in United States, Facts and Figures 2009. EPA Office of Solid Waste (5306P), EPA530-R-10-012, December 2010. United States Environmental Protection Agency.
- Van Kessel, L. 2005. Effective solutions to reduce the impact of waste arising from papermaking. Cost Action E48 Limits of paper recycling. Workshop presentation in Brussels, November 2005.
- Verkerk, H., Lindner, M., Anttila, P. and Asikainen, A. 2010. The realistic supply of biomass from forests. In: EUwood – Final report. Hamburg, Germany, June 2010. Pp. 56–79.

- Vesanto, P. 2006. Jätteenpolton parhaan käytettävissä olevan tekniikan (BAT) vertailuasiakirjan käyttö suomalaisessa toimintaympäristössä, Jätteenpolton BREF 2006. Suomen ympäristö 27/2006. Finland's environmental administration (SYKE). (In Finnish.)
- Villanueva, A. and Wenzel, H. 2007. Paper waste – recycling, incineration or land-filling? A review of existing life cycle assessments. *Waste management*, Vol. 27, pp. 29–46.
- Virtanen, Y. and Nilsson, S. 1993. Environmental impacts of waste paper recycling. International Institute for Applied Systems Analysis. Earthscan, London.
- Wernerfelt, B. 1984. A resource-based view of the firm. *Strategic management journal*, Vol. 5, No. 2, pp. 171–180.
- Westenbroek, A. 2009. Minimizing waste in paper recycling. Cost Action E48 – Final Conference, The Limits of Paper Recycling. Munich, 6.7.2009.
- World Trade Organization. Trade profiles by country. China, March 2011.
- WRAP 2008. Kerbside recycling: Indicative costs and performance. Research report (ROT-024), June 2008. Waste and Resource Action Programme.
- Wunsche, G. and Niemczyk, B. 2004. Managing rejects from recycled fiber plants. *Solutions!* July 2004, pp. 42–44.
- Young, J., Ferguson, K., Harrison, A. and Glowacki, J. 1993. Special engineering report: the mini-mill concept. *Pulp and Paper*, September 1993, pp. 39–95.
- Östman, A., Ristola, P., Sipilä, K., McKeough, P. and Mäkinen, T. 2005. Fuel ethanol supply alternatives for Europe: evaluation of a new concept based on reject fiber from MSW and other sources. VTT BioFuture project reports & publications.
- Øyaas, K. 2010. Wood Pretreatment – a remaining challenge in lignocellulosic ethanol production. First international conference on lignocellulosic ethanol. Copenhagen, 13.–15.10.2010.

Appendix I

Key statistics; including development of regional
RCP collection and utilisation volumes
and basic price data

I.1 Statistics on the development of recycled fibre supply and demand

Figure 1 shows the development of recovered paper supply in the main paper-consuming regions (Europe, US and China). During the 12-year period from 1995-2007 the collection volumes increased by ~70%, equivalent to almost 5% year-on-year growth. It is almost double the average growth in paper consumption, which naturally forms the base line for growth in collection volumes.

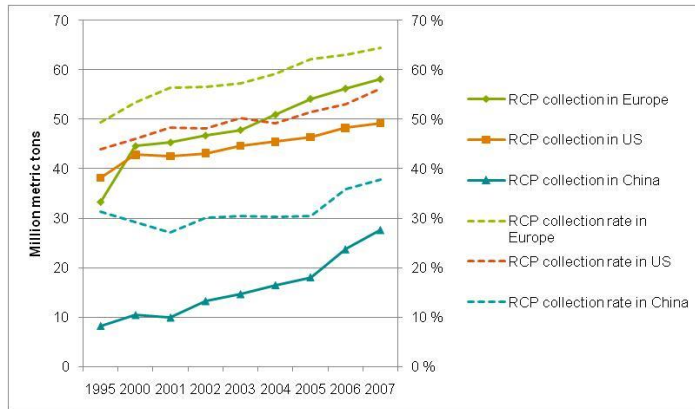

Figure 1. Development of recovered paper supply in main paper-consuming regions

Figure 2 shows the development of recovered paper demand in the main paper-producing regions (Europe, US and China). During the 12-year period from 1995-2007 the aggregate utilisation in these regions increased by ~84%, which translates into 5.2% year-on-year growth. In the same period, the combined utilisation rate of these regions increased from 39% to 50%. The strongest growth was in China, where RCP utilisation approached 70%.

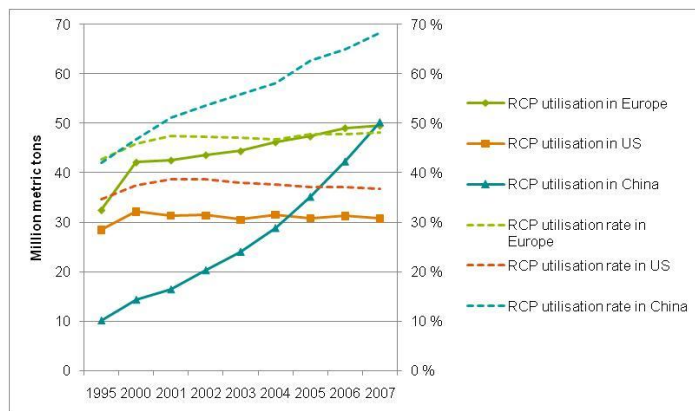

Figure 2. Development of recovered paper demand by main paper-producing regions

Figure 3 shows the development of the recovered paper supply and demand balance in the main market regions (Europe, US and China). The RCP surplus was and still is the most significant in the US, but Europe has also developed a significant surplus over the years. China currently has a deficit of more than 20 million tons annually.

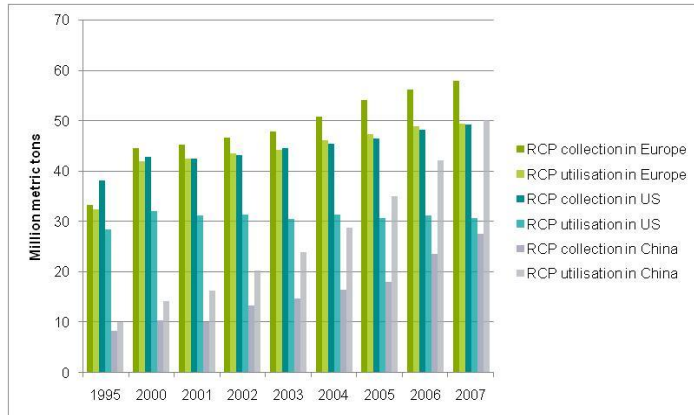

Figure 3. Development of recovered paper supply and demand balance in main market regions

Figure 4 shows the development potential of recovered paper supply and demand in the main paper-producing regions (Europe, US and China). The development potential is here represented by the regional collection and utilisation rates. A common perception in the industry is that it is very difficult to raise collection rates beyond 65-70%. This means that Europe might already have reached the collection level practically achievable. However, the US appears to possess significant collection potential.

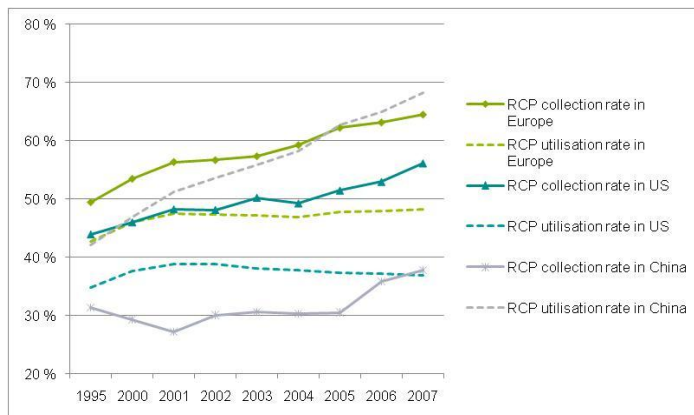

Figure 4. Development potential of recovered paper supply and demand in main paper-producing regions

Because of the large trade between China, the US and Europe, the collection rates are not 100% accurate or comparable. It is well-known that China exports a significant amount of packaging materials, manuals and brochures together with consumer goods. This phenomenon causes a certain systematic error in these statistics. It means that the actual collection rate in China is higher than the statistics suggest, and that the actual collection rate in the countries importing the packaged goods is actually somewhat lower than officially indicated.

I.2 Statistics on the development of the market price of recycled fibre

Figure 5 shows the development of nominal recovered paper prices in Germany. Over 20 years the trend price doubled, which translates into year-on-year growth of 3.5%. The real increase in the trend price, net of inflation, was thus very subtle. There is a clear contrast, however, with the trend prices of bulk paper products, which declined in the same time frame (Pöyry Forest Industry Consulting, 2009).

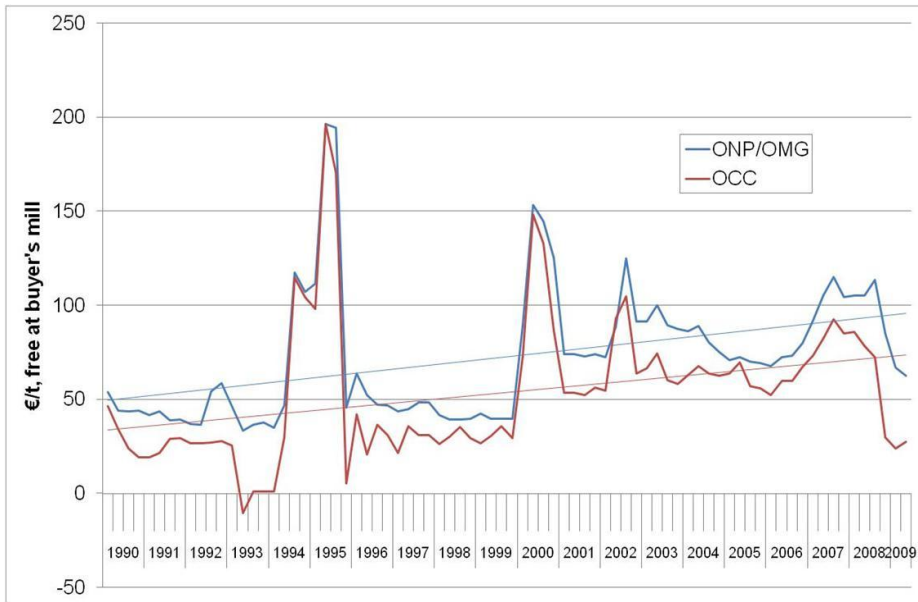

Figure 5. Nominal price development of OCC and ONP/OMG in Germany (Pöyry Forest Industry Consulting, 2009)

A very similar price trend was witnessed in the United States (see Figure 6). In the US the trend price of OCC rose an average of 4.4% year-on-year over 20 years. Interestingly, in the US the trend price of OCC surpassed the trend price of ONP by some 30 USD/t, whereas in Germany the situation was just the opposite – with a slightly smaller difference of some 15-20 €/t on average. The explanation for this phenomenon lies, on the one hand, in the local supply-demand structure. In Central Europe, the production of printing papers is more RCF-based than in the US and thus there is strong local demand. Especially in the densely populated US east coast there is a large surplus of ONP. On the other hand, the US OCC has much better strength properties than the European OCC. This is due to the structure of the local case-materials-producing industry, which is still largely virgin-pulp-based, whereas over 90% of the European case materials industry is 100% RCF-based. Therefore, US OCC typically commands higher prices on the market than European OCC. Naturally, the strong fluctuation in the USD-EUR exchange rate also plays a major role in the competitiveness of US vs European OCC on the international export market.

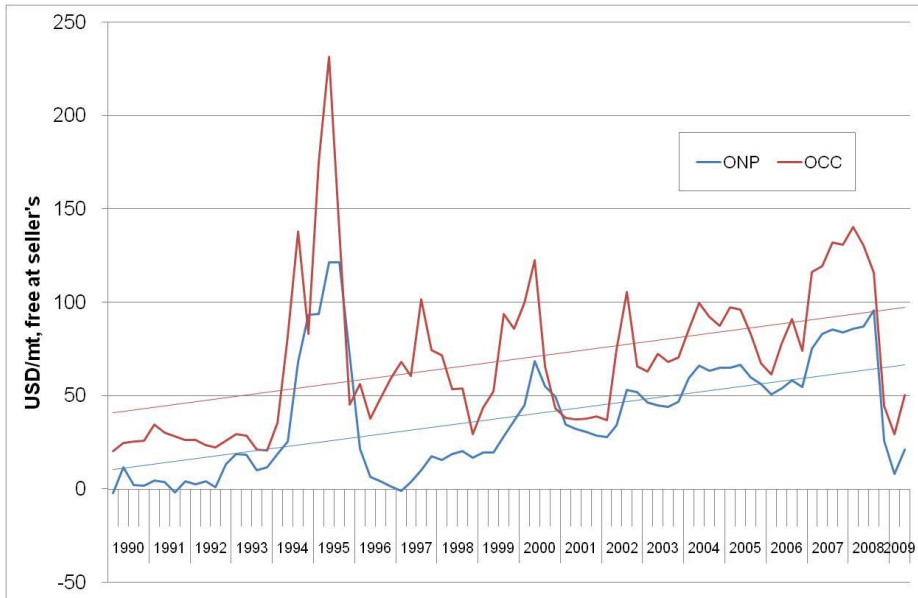

Figure 6. Nominal price development of OCC and ONP in the US – an average of New York and Chicago prices (Pöyry Forest Industry Consulting, 2009)

Data sources used in summarising the supply and demand statistics¹:

1. Europe: CEPI² (Confederation of European Paper Industries , www.cepi.org)
2. USA: AF&PA (American Forest & Paper Association, www.afandpa.org)
3. China: China Paper Almanac 2007

¹ All figures have been edited by the author to correspond as well as possible with the definitions of utilisation and collection rates used by CEPI. Any eventual discrepancies in the figures are likely to be minor and should not influence the conclusions of this study in any way.

² CEPI statistics cover countries that are members in CEPI, i.e. AU, BE, CZ, DK, FI, FR, DE, HU, IR, IT, NE, NO, POL, POR, SLO, SP, SWE, SUI, UK. CEPI countries' share of european paper consumption and production averages >90% of total geographical Europe (including non CEPI-members, such as Russia).

Appendix II

Delphi study on supply – demand behaviour of
recycled fibre; invitation letter and
problem description

12.9.2010

Aalto University / Helsinki University of Technology
Department of Industrial Engineering and Management

Doctoral student Petri Ristola (petri.ristola@metso.com)

NEW COMPOSITE DEMAND OF RECYCLED FIBRE DUE TO DEVELOPMENTS IN WASTE-TO-ENERGY

Delphi study on supply – demand behavior of recycled fibre

Dear x,

You are kindly invited to participate a delphi panel that aims at creating an expert opinion (or alternative opinions) on the supply-demand behavior of recycled fibre (RCF). This delphi panel relates to my research of waste-to-energy in RCF-based paper industry. Especially in the European context a hypothesis has emerged, that the on-going developments in Waste-to-Energy will create a fuel market for various waste flows with varying RCF content. This anticipated development might in the long run affect the supply-demand balance of recycled fibre, primarily visible in price development of commercial recovered paper grades (RCP). For the purpose of understanding the likely market effects of the said developments, I have constructed a qualitative supply-demand model which I intend to quantify for selected sub-sets of the market and thus also validate the more generic model.

The sub-sets of the market selected for analysis are:

- 1) The market of old newsprint and magazine (ONP/OMG) for manufacture of newsprint in Europe
- 2) The market of old corrugated containers and mixed waste paper (OCC/MW) for manufacture of containerboard in Europe

In terms of volume, these markets together represent >60% of total RCP utilisation in Europe.

For both of these I aim to quantify the main factors affecting supply and demand:

- a) Volume development of the utilisation capacity
- b) Price development of the substitute (=virgin fibre)
- c) Volume development of the collection
- d) Price development in alternative utilisations (i.e. outside papermaking)

The study begins by semi-structured interviews on the themes of the study, examples of which are listed below:

- Identifying factors affecting development of RCF utilisation (demand)
- Identifying factors affecting development of RCF collection (supply)
- What explains price trends of different RCP grades (in the past)?
- Technical development in RCF utilisation
- The on-going implementation of bioenergy and waste-to-energy at paper mill sites
- Technical development in Waste-to-energy, including production of 2nd generation biofuels
- Inter-action of the European and the global market, with regard to RCF raw materials as well as supply and demand for various paper products, especially the role of Chinese market
- Policies aiming at reducing CO₂-emissions; their impact on the RCF market; Their impact on substitute price development (virgin fibre) and other factors of production (e.g. electricity)

I will contact you in near future in order to schedule the Round 1 interview with you.

Thank you for your kind consideration of participating this study!

Best regards,
Petri Ristola

Enclosures 1 – Description of the Delphi method
 2 – Tentative list of panelists
 3 – Trends to be evaluated
 4 – Background statistics on recycling volumes and prices

DELPHI STUDY ON SUPPLY – DEMAND BEHAVIOR OF RECYCLED FIBRE

Enclosure 1, description of the Delphi method

Composition of the Delphi Panel:

The composition of the delphi panelists is designed to cover expertise in all the factors affecting the development of supply and demand of RCF in general, and especially in the subsections of the market selected for quantification:

- 1) The market of old newsprint and magazine (ONP/OMG) for manufacture of newsprint in Europe
- 2) The market of old corrugated containers and mixed waste paper (OCC/MW) for manufacture of containerboard in Europe

Main factors affecting supply and demand:

- a) Volume development of the utilisation capacity
- b) Price development of the substitute (=virgin fibre)
- c) Volume development of the collection
- d) Price development in alternative utilisations (i.e. outside papermaking)

Tentative composition of the panel is attached as enclosure 2. Target is also to utilise snow-ball sampling, so that additional suitable panelists would be proposed by the interviewees.

The Trend-Delphi method:

As characteristic to the method, the delphi process consists of two rounds:

Round 1: semi-structured interviews on the themes of the study

Round 2: commenting the argumentation gathered from the panelists in Round 1

Round 1 interviews are carried out as semi-structured face-to-face interviews covering the themes of the study. The interviews aim at crystallizing arguments that support or oppose specific future developments in the field of the study. Specifically, each interviewee will be asked to take a stand to the likely development of statistical trends illustrated in enclosure 3. After each interview I, in the role of delphi manager, will draft a summary of the interview and the arguments raised in the discussion. The summary will be sent to the interviewee for comments and approval.

After the Round 1 has been completed, I will compose a summary of its results. The summary will contain the arguments raised in the Round 1 interviews grouped by the analysed factors of supply and demand. The arguments will be presented anonymously, so that the panelists are not able to know from whom they originate.

In Round 2, the panelists are requested to take stand to raised specific arguments, for or against, and are also given a possibility to justify their stand. The panelists are asked to comment specifically those arguments that relate to factors of supply or demand, that they have special expertise in, but are free to comment any arguments under other categories as well. Round 2 will be conducted by an email questionnaire where the final task of the panelists will be to once again take a stand to future development of the specific statistical trends, preliminarily illustrated in enclosure 3. The panelists are completely free to change their stand compared to the responses they gave during the Round 1.

After the Round 2 has been completed, I will draft a summary of the results and circulate that to the panelists. The results of the study will be published as part of my dissertation. As part of the results, the composition of the Panel will be published but not the arguments, opinions or comments of individual panelists. This is characteristic to the Delphi method, that the panelists and the individual comments are not connected.

Enclosure 2. List of panelists and their areas of expertise

Name	Organisation	Specialty	Areas of expertise (preliminary classification, panelists are free to edit)				
			a)	b)	c)	d)	e)
1 Magnus Diesen	Aalto University, ex Stora Enso	Bus. dev. / general industry expertise, investments	X	x			
2 Timo Suhonen	Pöyry	Pulp & paper markets in general, price elasticity	x	X			
3 Ilpo Ervasti	Private consultant	RCP market, statistics	x		X		
4 Kai Sipilä	VTT	Waste-to-energy, research and EU policies		x	x	X	
5 Esa Sipilä	Pöyry	Waste-to-energy, waste EtOH		x	x	X	
6 Lassi Hietanen	L&T	Waste management, bus. dev.		x	x	X	
7 Jarno Hellman	L&T	Market of secondary raw materials (RCP, RDF, etc.)			X	x	
8 Seppo Oikarinen	UPM-Kymmene Deutschland	RCP sourcing	x		X	x	
9 Osmo Kuusi	VATT	Global biofutures			x	x	X
10 Herdis Ous	StoraEnso Deutschland	RCP sourcing / Business intelligence	x		X		
11 Hartmut Wurster	UPM-Kymmene Deutschland	Bus. dev., recycled fibre, investments, market	X	x	x		
12 Thomas Glorius	Remondis	Waste management, R&D			x	X	
13 Kaija Pehu-Lehtonen	Botnia	Virgin pulp, bus. development		X			
14 Markku Karlsson	UPM-Kymmene	Bus. dev. / general industry expertise, R&D	X	x		x	
15 Pauli Hänninen	UPM-Kymmene	Mechanical fibre, bus. development, investments	x	X			

Areas of expertise

- a) Volume development of the utilisation capacity
b) Price development of the substitute (=virgin fibre)
c) Volume development of the collection
d) Price development in alternative utilisations (i.e. outside papermaking)
e) Other, i.e. related areas

X = primary area, x = secondary area

Number of primaries	3	3	4	4
Number of secondaries	5	6	6	4
Total	8	9	10	8

Enclosure 3 - Selected trends

A. SUBSTITUTE PRICE DEVELOPMENT

A1. Price of pulpwood of spruce in Sweden. (Major component in TMP mfg cost)

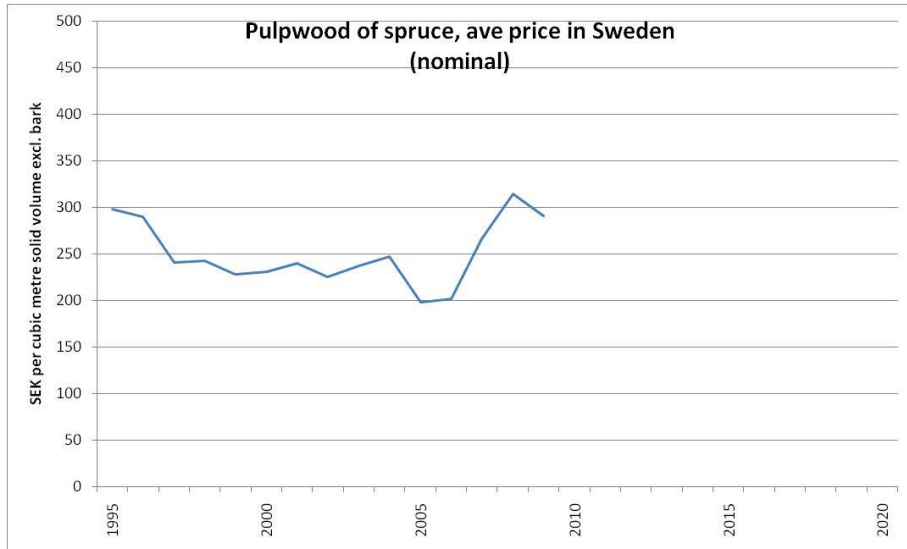

A2. Price of electricity. (Major component in TMP mfg cost)

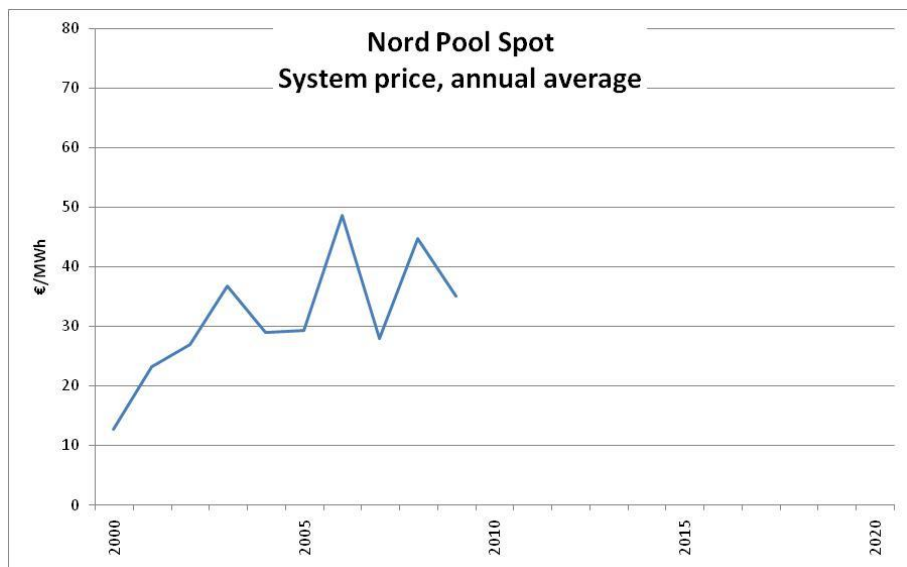

A3. Price of BSKP. (As proxy of unbleached kraft)

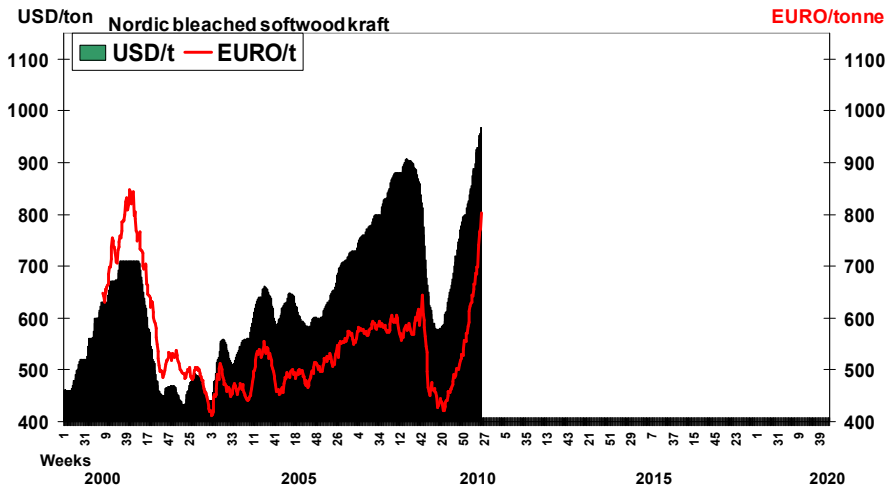

B. VOLUME DEVELOPMENT IN UTILISATION

B1. Volume development in utilisation; ONP/OMG and newsprint in Europe¹

B2. Volume development in utilisation; OCC/MW and containerboards in Europe

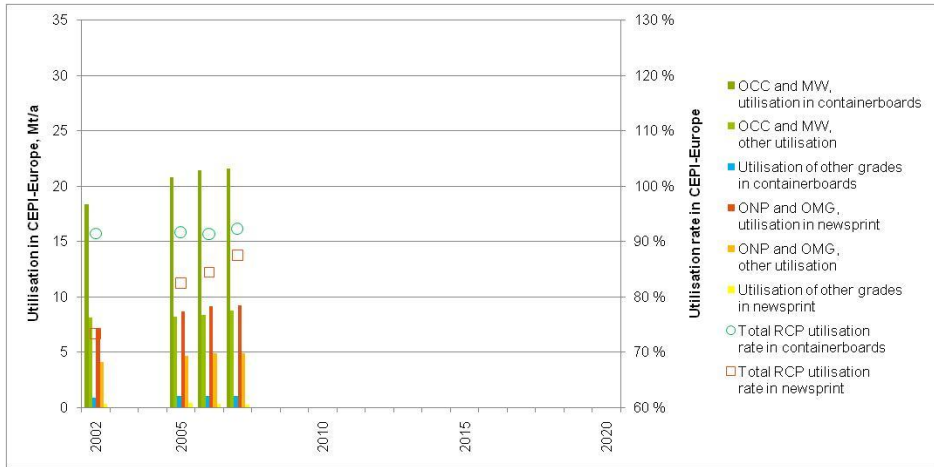

¹ In all the statistics “Europe” refers to the members of CEPI, i.e. AU, BE, CZ, DK, FI, FR, DE, HU, IR, IT, NE, NO, POL, POR, SLO, SP, SWE, SUI, UK. CEPI countries’ share of european paper consumption and production averages >90% of total geographical Europe (including non CEPI-members, also Russia).

C – VOLUME DEVELOPMENT IN COLLECTION

C1. Development of RCP collection and collection rate in Europe (CEPI Europe).

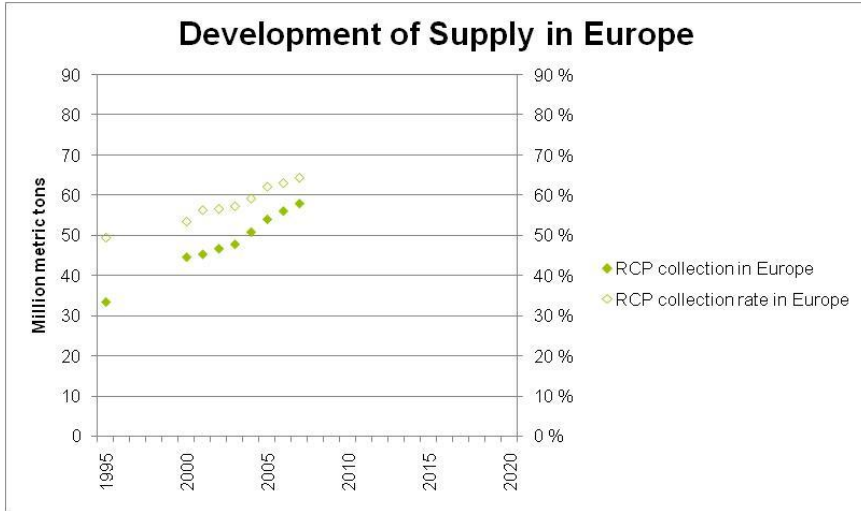

D – PRICE DEVELOPMENT IN ALTERNATIVE UTILISATIONS

As fuel use of wastes is anticipated to emerge as a indirect alternative utilisation for RCF containing waste flows, important is to understand how energy and fuel markets might develop in future.

D1. Price development of CO₂-credits. (Relevant to price development of fuel wood and different biomass containing waste-based fuels)

Excerpt from Inagendo Factbook. (www.inagendo.com)

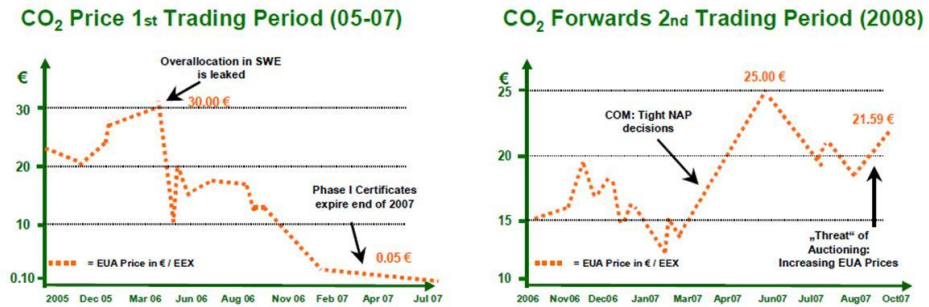

Please estimate price of CO₂-credits €/t in 2015: _____
 2020: _____

D2. Price development of transportation fuels. (Relevant to competitiveness of ethanol and biodiesel made of wastes)

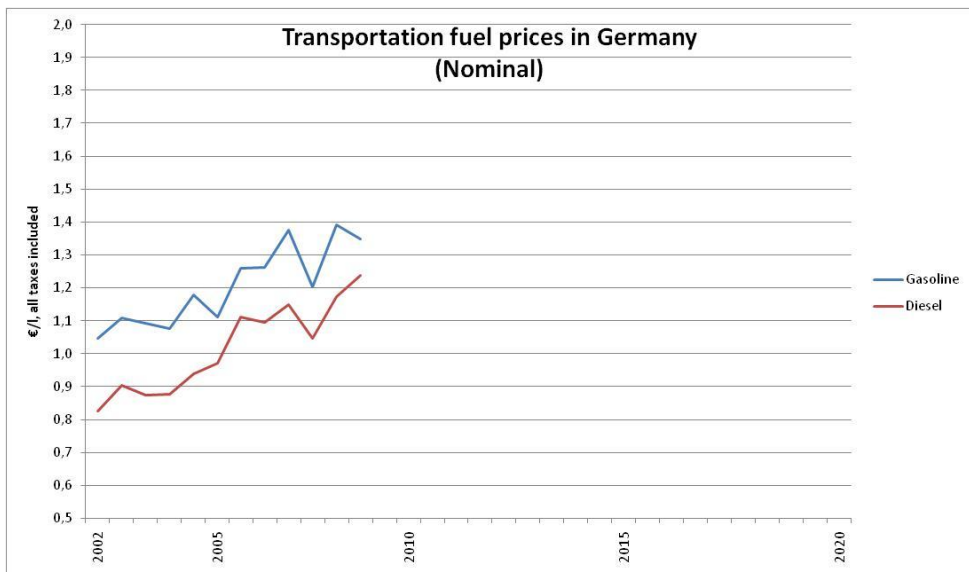

Note: Price development of electricity already handled as item A2.

Background statistics:

Historical variation of Nord Pool spot price on daily level (system price)

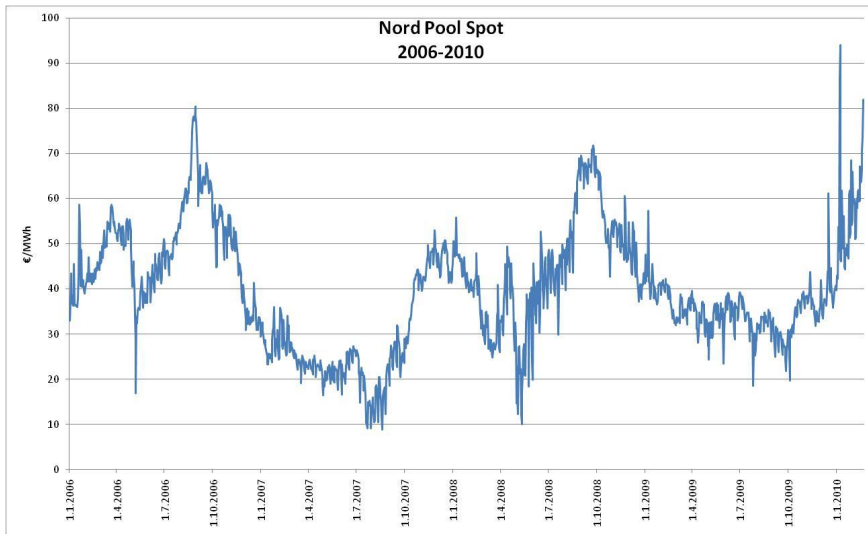

Enclosure 4 - Background statistics on recycling volumes and prices

Same as Appendix I. Content is not repeated here.

Appendix III

Delphi study on supply-demand behaviour of recycled fibre; summary of 1st round findings and the 2nd round questionnaire

20.9.2010

Aalto University / Helsinki University of Technology
Department of Industrial Engineering and Management

Doctoral student Petri Ristola

Delphi study on supply – demand behavior of recycled fibre

Round 2 - email questionnaire

This document summarises the 1st round findings of the delphi panel on supply-demand behavior of recycled fibre. It contains the key argumentation that the panelists are kindly asked to respond to. The email responses to this argumentation form the 2nd round of the delphi panel. After receiving the responses, a report of the findings will be prepared and distributed back to the panelists.

petri.ristola@metso.com
+358 40 537 3798

20.9.2010

CONTENTS:

1.	Foreword	p. 3
2.	Background	p. 5
3.	General description of the supply – demand model	p. 6
3.1	Description of the model	p. 6
3.2	Summary of hypothesis related to basic market phenomena	p. 11
4.	Key argumentation for panelists to comment (2 nd round)	p. 13
4.1	Demand development of RCF at paper mills	p. 14
4.2	Substitute price development	p. 20
4.3	Supply development	p. 30
4.4	Market development related to energy utilisation of RCF	p. 34

APPENDICES:

I	Key comments from the 1 st round discussions	p. 41
I.i	Demand development of RCF at paper mills, i.e. RCP utilisation rate	p. 42
I.ii	Substitute price development, i.e. virgin fibre price development	p. 51
I.iii	Supply development, i.e. development of RCP collection rate	p. 53
I.iv	Market development related to energy utilisation of RCF	p. 60
II	Historical utilisation and collection volumes of RCP at main market areas (Separate document)	
III	Quarterly RCP price statistics in the US and German markets (Separate document)	
IV	List of panelists and their areas of expertise (Separate document)	

20.9.2010

1. FOREWORD

This document summarises the 1st round findings of the delphi panel on supply-demand behavior of recycled fibre. The 1st round of the study consisted of face-to-face interviews of all 15 panelists and was carried out during February-September 2010. Each interview consisted of an open-ended discussion of the study themes followed up by a structured section where each panelist was requested to give her/his opinions on the development of selected key trends together with the relevant argumentation.

Summary of the 1st round findings and the panelists' views on development of the relevant trends are presented as Chapter 4 of this report. Appendix I contains a more thorough report of the observations brought up by the panelists during the open-ended discussions. The summaries presented under Chapter 4 include "Links" to relevant quotes in the open-ended interviews (Appendix I). The "Links" are functional only in the Word-version of the document. Appendix I includes several "Back"-links that lead the reader back to the main text.

As the 2nd round of the study, the panelists are now kindly asked to:

- a) Read this report to familiarise themselves with preliminary findings of the panel
- b) Review and comment in writing the trends and argumentation collected in Chapter 4. At least those that belong to each panelist's area of primary and secondary expertise (see Appendix IV).
- c) Give written feedback to any part of this report.

The panelists's responses are wished by email latest October 17th, and can be of whatever form, e.g. this word file edited with "track changes" -function on, bulleted list of comments referring to this report, scanned pages of this report with hand written comments, or anything else.

After receiving all responses, a final report of the study findings will be prepared and distributed back to the panelists.

This document also contains a brief background to the study (Chapter 2) as well as a general description of the supply – demand model of RCF, as drafted by the author (Chapter 3). All commentary to the general model are also most welcome.

20.9.2010

On key terminology: Recovered paper (RCP) and Recycled fibre (RCF)

The commonly adopted term recovered paper (RCP) refers to the used paper and board collected for purposes of utilisation at paper and board mills. Standard EN-643 provides definitions of RCP grades and acts as the basis for commercial transactions, mainly in Europe. In other main markets of US and China similar classifications are in use.

This study uses the term recycled fibre (RCF) to cover all expressions or forms of used paper fibres, not only as RCP but also those mixed in other waste flows. Obviously the main functioning market of RCF is the supply of RCP for use at paper and board mills. In future, RCF content in also other wastes may develop significant value, e.g. as biofuel or source of sugars for chemical conversion. Thus this research looks at the whole composite market of different RCF containing waste flows.

On top of the RCF traded as RCP, it has been estimated that presently 5-7% of RCF is utilised outside paper industry: in molded products, as insulation material, animal beddings, etc. Rest of the RCF exits the circulation to land fills, sewer system and in waste incineration.

On Delphi-method:

The purpose of the present Delphi-panel is to create an expert opinion on likely developments in the RCF market, especially in the light of increasing investments in bioenergy in general and in waste-to-energy at paper mills in particular.

The Delphi-panel is not an opinion poll. It is an attempt to create a balanced and well argued view of the likely developments and also to identify alternative scenarios of the market development. Averaged opinions of the panelists have only little value, but those viewpoints backed up by the strongest argumentation will be given most attention when interpreting the results of the panel. In this respect the second round of the panel has crucial importance as it shares all argumentation presented in the first round interviews and pushes the panelists to further clarify argumentation of their own and to challenge the one of the others.

In Delphi-method the names of the panelists are published but all comments are kept anonymous¹. Also in this report, the author has removed from the quotes any direct reference to individual companies and persons participating this panel. The same applies naturally to the upcoming final report of this panel.

¹ This is actually a central feature of the Delphi-method. Keeping all comments and arguments anonymous guarantees their equal treatment in the panel – regardless of position and known merits of individual panelists behind the comments.

20.9.2010

2. BACKGROUND

The purpose of this delphi panel is to increase understanding on supply – demand behavior of recycled fibre, especially on how current developments in waste-to-energy might influence it in the long run. The study is related to author's preparation of a PhD thesis on waste-to-energy concepts at recycled fibre paper mills and on their likely implications on the RCF market.

In author's research it has been revealed that major investments in waste-to-energy are already in progress at various paper mill sites in Europe. Straightforward financial analysis of a typical investment leaves little doubt whether this development will continue. The benefits are based on strong operational synergies between waste-to-energy and recycled fibre based papermaking. At the same time several 2nd generation concepts are under piloting and will further increase investment alternatives.

It is an interesting question to the recycled fibre utilising paper industry as well as for the supplying companies operating in the waste collection, how these developments are likely to change the market for recycled fibre. The long term effects are important e.g. from the point-of-view of investment prioritisation.

3. THE SUPPLY – DEMAND MODEL OF RECYCLED FIBRE

3.1 Description of the model

Figure 3.1 presents an overview to the general model of composite RCF supply and demand – in its different physical forms. The purpose of the model is to create an overview of the potentially intertwining and overlapping markets of RCF in different end uses (which respectively tolerate different physical forms). In this general and simplified model the supply and demand of RCF split into three main components: a) as recovered paper – RCP, b) as fuel – e.g. SRF and c) as waste to be disposed of e.g. in landfills or in waste incinerator plants – MSW². In the graph these quantities are respectively marked as Q_{RCP} , Q_{SRF} and Q_{MSW} .

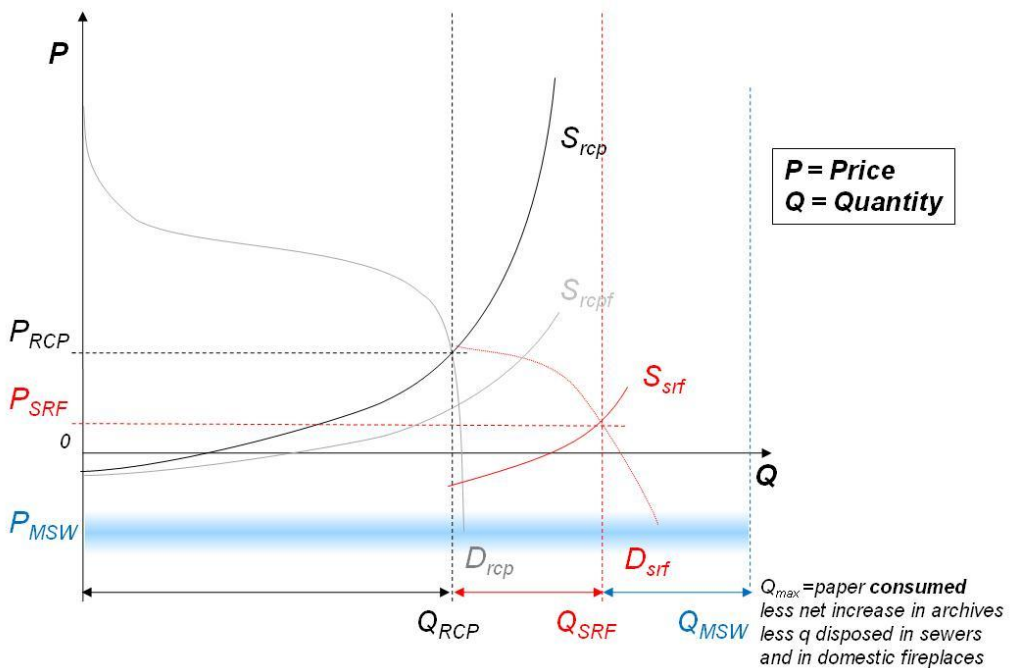

Figure 3.1. General model of composite demand and supply of RCF.

Here it is assumed that the total RCF content in these flows (Q_{MAX}) corresponds with the total amount of RCF generated (=paper consumed) less net increase in archives, less quantity disposed in sewers, less quantity burned in domestic fireplaces. In other words, the total available RCF quantity is fixed (by

² This model is obviously highly simplified. In reality, RCP alone is of course not a homogenous market but traded in different commercial qualities all with individual supply and demand schedules. The P_{RCP} in this model represents the price of the marginal quantity Q_{RCP} . In practise this is the market price of the mixed waste paper. Furthermore, there are also other alternative end uses to RCF than fuel such as insulation material, as molded products, as animal beddings etc. However, for reasons of understanding the basic interplay between the different markets, the distinction is here made between the fibre use, fuel use and disposal.

20.9.2010

consumption), only the split of amounts appearing on these different markets vary according to current demand and supply curves on different markets. Together the total RCF content in these quantities makes up the total available volume of RCF ($Q_{RCP}+Q_{SRF}+Q_{MSW}=Q_{MAX}$).

Whereas each ton of RCP carries also a small amount of foreign non-fibrous material, each ton of SRF carries not only the RCF content of the fuel but also at least similar amount of other combustible materials as well as a small amount of non-combustible impurities. In MSW one finds today relatively small amount of RCF but a lot of other trash. In other words, by the definition used in this model, the Q_{SRF} represents only the RCF content in SRF flows and is therefore only about a half of the total tonnage of SRF traded today. Similarly the Q_{MSW} of this model represents probably far less than a third of the total MSW tonnage disposed. This model treats the material fractions found in SRF with equal average price, the average price thus also applicable for its RCF content.

The model described in Figure 3.1 shows how the price and quantity in each of these markets is defined by the balance of respective supply and demand, i.e. the intersection of the S and D curves. In other words Q_{RCP} is traded at P_{RCP} based on balance of supply and demand. The demand of RCF as RCP, D_{RCP} depends on demand and price of different recycled paper products and paying capacity of their upstream value-chains. This paying capacity is also affected by the prices of other factors of production in paper-making and the quality of the installed manufacturing capacity base. As a result the total paper industry displays a certain demand for RCP (D_{RCP}). Respectively, the RCP supplying companies display a certain supply curve that in theory equals their marginal manufacturing cost curve and at a given point in time these curves intersect at Q_{RCP} , P_{RCP} . This is the equilibrium point into which the market would settle when all conditions were held constant.

The margin of Q_{MAX} and Q_{RCP} in the figure 3.1 remains to be split between the fuel and waste disposal markets. Here the D_{SRF} is the demand curve displayed by the potential users of refuse derived fuels for material flows suitable to be used as fuel. The shape of D_{SRF} reflects the paying capacity of different power plants (and the today very few chemical conversion facilities) for the RCF containing refuse derived fuel flows. In this model the value of RCF within a given SRF flow can be considered equal to its other components, i.e. all components in SRF share the same average price per ton. The shape of the supply curve S_{SRF} comes from the marginal mfg. cost curve of suppliers of these flows. Thus the intersection of S_{SRF} and D_{SRF} dictates the quantity and price of RCF traded as SRF (Q_{SRF} and P_{SRF} , respectively). Here we note that the actual size of the SRF-market remains at least double – when we add up the tonnage of other material fractions included in SRF.

The remaining margin between Q_{MAX} and $Q_{RCP}+Q_{SRF}$ remains on the MSW market. In this model the MSW market is not paid much attention. It is simply assumed that there is indefinite demand, i.e. sinks for waste either as landfills or waste incinerator plants. The demand curve for the waste disposal (D_{MSW}) is therefore reasonably flat and lies somewhere at a price level of -100 €/t. In other words, in model described above all RCF content that is not sorted or processed out of different waste flows either as RCP or as SRF remains to be disposed of and the price level of this service (i.e. tipping fee) is somewhere around -100 €/t.

Let's next have a little closer look at the supply curve of RCP, figure 3.2. The manufacturing cost structure of different suppliers or quantities is respectively dependent on stumpage price of different sources (sometimes negative), transportation cost and sorting cost. Quantities Q1-Q4 in figure 3.2 illustrate clearly different cost structures – some are transportation biased, some sorting biased, some have negative, some have zero and some have positive stumpage values.

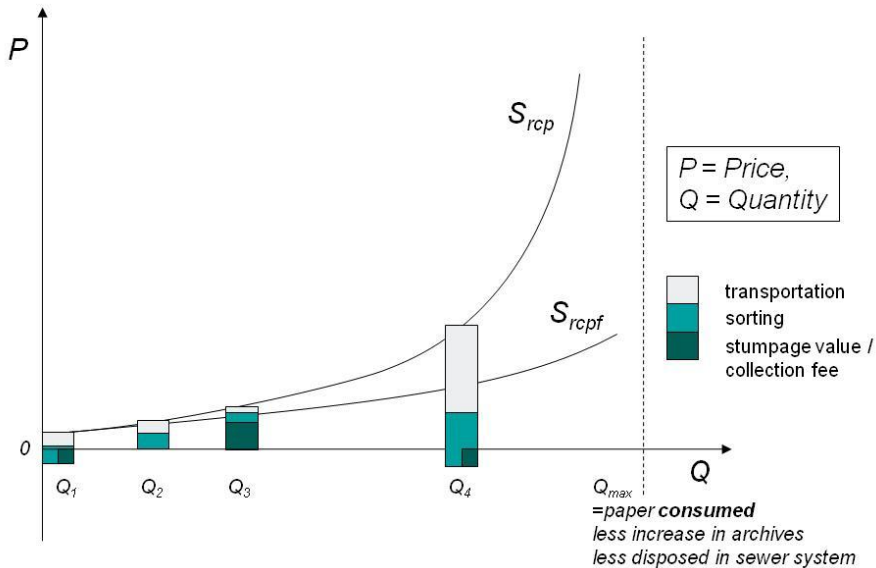

Figure 3.2. Illustration of typical cost structures behind RCP Supply-curve (S_{RCP}) and its shadow curve, the supply of RCP as fuel (S_{RCPF}).

In addition to supply curve of RCP, the figure 3.2 displays its shadow curve, the manufacturing cost curve of the RCP as fuel (S_{RCPF}). In theory, each quantity traded to the RCP market could be traded on the fuel market with somewhat lower cost. The difference in the manufacturing cost S_{RCP} and S_{RCPF} consists mainly of reduced need for sorting as well as somewhat simplified collection, i.e. lower transportation cost.

This means that the supply curves S_{RCP} and S_{SRF} of Figure 3.1 are interconnected through the S_{RCPF} . Consider a waste management operator handling a given lot of material rich in waste paper but containing a relatively large share of foreign material most of which is combustible. It may decide to just skim the easiest fraction of the material lot by sorting it into a given grade of RCP and putting rest of the material into the SRF market, or based on market conditions (demand and consequently price), it may decide to take all the efforts and cost to sort maximum of RCP out of the material lot and produce hardly any tailings to the fuel market. On the other extreme the WM operator could even combine collection of this flow with some of the fuel fractions requiring less sorting and thereby saving in transportation/collection cost.

This connection is the central element of the combined RCF supply-demand model. S_{RCPF} reflects the manufacturing cost of fuel out of the flows normally sorted and sold as RCP. Typically the difference in mfg cost between S_{RCP} and S_{RCPF} is just the additional sorting needed to perfect a given flow into a commercial RCP grade. Logically this gap tends to increase by the quantity, i.e. as the flows become more and more costly to sort into commercial quality RCP. In this model, the markets of RCF as RCP and as SRF keep separate as long as there is no producer's surplus available on the SRF market for the marginal quantity Q_{RCP} (which by definition commands a zero producer surplus on the RCP market). In the Figure 3.1 the price of SRF, P_{SRF} is still below S_{RCPF} for the marginal quantity Q_{RCP} and no mix between the two markets takes place.

When these different markets continuously develop, it means that each supply and demand curve are continuously changing position against each other and more slowly also their shape. Naturally, big regulatory moves, such as taxes and subsidies can cause very rapid movements in the position of these shapes. Examples of such would be landfill tax or CO₂-credits for the renewable share of waste derived fuels.

Largely based on the results of the Delphi panel in hand, the author aims at drawing conclusions on how the composite RCF market as a whole is likely to develop. In essence this question focuses around the interconnection of RCF supply either as RCP or as fuel (including feedstocks to different processes of chemical conversion) and the demand development in the mentioned two utilisations. The following charts illustrate the present hypothesis of the author how the system will work.

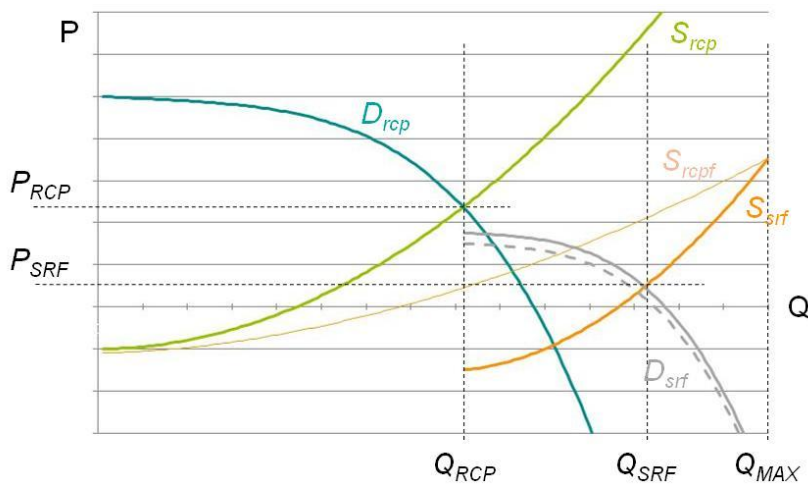

Figure 3.3. Composite market of RCF as recovered paper and as recovered fuel. The solid line D_{SRF} describes the increase in the fuel demand up to the point where the marginal Q of RCF on paper market reaches zero surplus also on the fuel market. I.e. Prices P_{RCP} and P_{SRF} reach a balance.

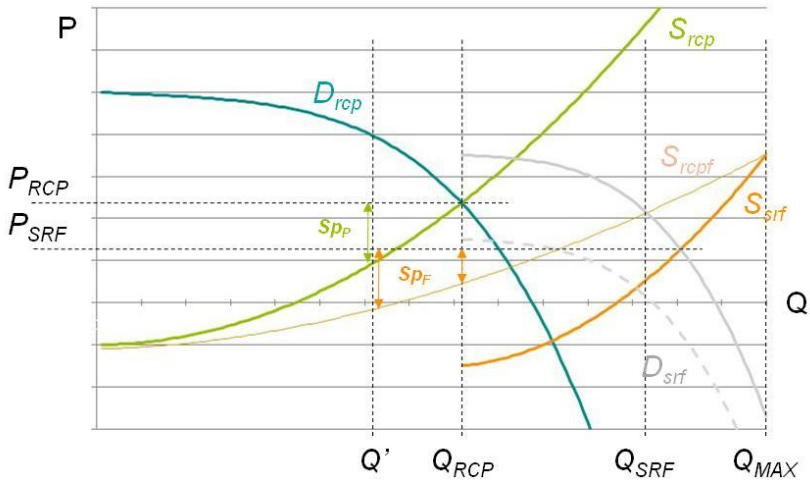

Figure 3.4. Demand of recovered fuel increases yet further so that the marginal Q of RCF on paper market (Q_{RCP}) would yield clear surplus on the fuel market (Sp_F). All quantities beyond the Q' - where surplus of RCF on the paper market (Sp_P) matches the one on the fuel market (Sp_F) - are threatened to move to fuel market.

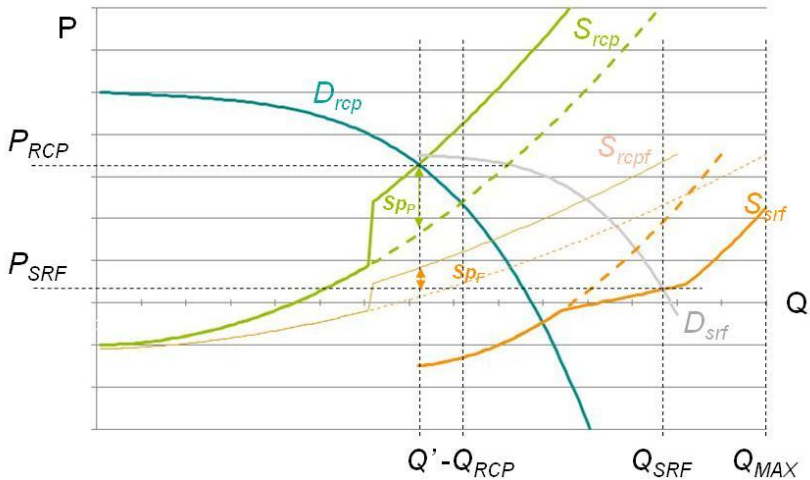

Figure 3.5. A quantity of RCF ($Q' - Q_{RCP}$) has moved from paper to fuel market, giving a new shape to both S_{RCP} and S_{SRF} . When D_{RCP} and D_{SRF} remain static, the result is a steep increase in RCP price as well as a decrease in SRF price. In the resulting situation the quantities moved to the SRF market are not anymore as competitive as they would have been on the RCP market.

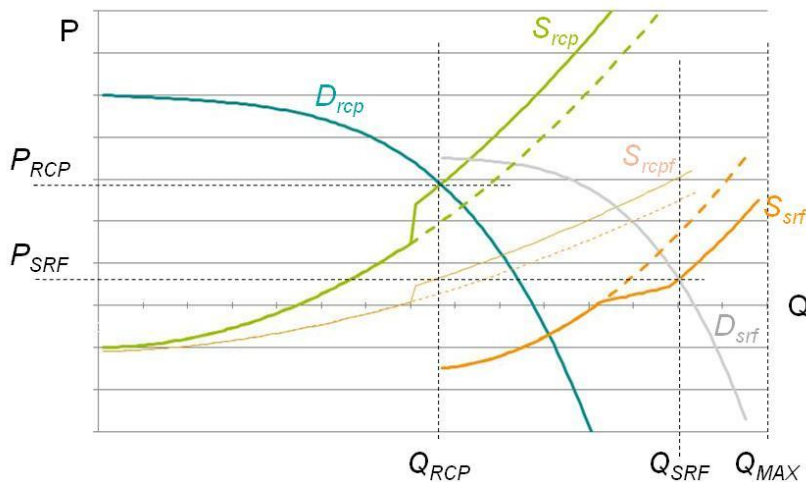

Figure 3.6. A balance is found, where slight bleed of RCF from paper to fuel market causes some increase in RCP price and a corresponding decline in SRF prices. Now the system is back in balance, i.e. the marginal quantity of RCF on the paper market again has a zero surplus both on the paper and fuel markets.

3.2 Summary of hypothesis related to basic market phenomena

This chapter summarises the present hypothesis how different changes in the market conditions will be reflected by changes in the various demand and supply schedules in the described general model.

a) Development of demand for RCP

Demand for RCP develops in long term by investments in RCP utilisation capacity (such investments that increase RCP's market share in the papermaking rawmaterial mix). Such development moves the RCP demand curve to the right.

Typical short term changes in operating rate of the industry can be interpreted as changes in paying capacity of the utilising industry, and reflected mainly by a vertical movement of the demand curve.

All in all the demand development for RCP is ultimately based on the development of upstream demands of different paper products, including the effects in the markets of other factors of production. Thereby the shape and elevation of the demand curve are in continuous but relatively slow change.

b) Changes in the virgin fibre (substitute) price

Changes in virgin fibre price will eventually change the elevation of the demand curve, *ceteris paribus*. For instance if price of virgin fibre rose, it would eventually improve the paying capacity of the utilising industry for the recycled fibre.

20.9.2010

c) Development of RCP supply

Development of RCP supply takes place by improving and extending the collection and investments in sorting plants. I.e. improving the retention of current collection schemes and by establishing new collection schemes

As a generalisation, establishing new collection schemes moves the RCP supply curve to the right and improvements in the collection and sorting systems impact the shape of the supply curve.

d) Development of the shadow supply –curve (RCP as fuel).

Shape of this curve is dependent on the collection and sorting systems in place and the ways how they can be used in simplified form for production of the fuel grade.

e) Development of SRF demand curve.

Development of demand for SRF takes place by investments in modern waste-to-energy.

These investments move the demand curve to the right. (Rather slowly, because movement takes place in proportion to the RCF content in the fuel flows)

Different subsidies and taxation benefits have the potential to move the demand curve in vertical direction, causing rapid changes in the equilibrium price of SRF.

f) Development of SRF supply curve.

Development of supply of SRF takes place by investments in collection schemes and sorting capacities and improvement of retention of current schemes.

Such development moves the supply curve to the right. (Slowly, because in proportion to the RCF content in the fuel flows) Also improvements in the systems will slowly change the shape of the curve.

20.9.2010

4. KEY ARGUMENTATION FOR PANELISTS TO COMMENT (2nd ROUND)

This chapter presents a summary of the 1st round findings including the trends and the key argumentation presented by the panelists in favor or against. This Chapter is organised under the four main headings:

- 1) Demand development of RCF at paper mills
- 2) Substitute price development
- 3) Supply development, i.e. development of RCP collection rate
- 4) Market development related to energy utilisation of RCF

The panelists are asked to give their evaluation and comments in the key arguments highlighted in this Chapter 4. As minimum, each panelist is asked to review and comment his/her own primary and secondary expertise areas but comments in all areas are naturally highly appreciated and useful.

Note: Hyperlinks in the document lead to relevant quotes that came up during the open-ended discussions of the 1st round interviews (Appendix I). Hyperlinks can be followed by clicking ctrl + mouse. Returning to main text can be done by selecting the back –link (ctrl + mouse).

20.9.2010

4.1 Demand development of RCF at paper mills

4.1.1 Summary

Following main observations represents the summary of all observations brought up in the 1st round interviews. Behind the links can be found detailed elaboration from the interview memos (Appendix 1).

1. Growth in utilisation of RCP will continue³. [Quotes](#)
2. Technical development in RCP and RCF processing will continue to create room for increase in demand. [Quotes](#)
3. The market development in the export markets, mainly China but including also India and other Asian economies suffering from fibre deficit will be the decisive component in demand development. European development plays clearly smaller role. [Quotes](#)
4. In short-term the operating rate of paper mills is the most important factor setting the demand of RCP whereas its price has only small impact. Current perception is that the price of RCP will remain high for quite some time due tight supply of RCP. [Quotes](#)

Do you in general agree with the summary presented above? _____ (YES/NO)

Please, feel free to elaborate your viewpoints on the above:

³ Several consultants have published reports supporting this assumption. E.g. PÖYRY's World Fibre Outlook 2025 report forecasts continuing growth.

4.1.2 RCP utilisation rate in manufacturing of newsprint

Manufacturing of newsprint represents the dominant end use of ONP/OMG grades. The history figures in the below chart are from CEPI and they thus cover CEPI-members⁴.

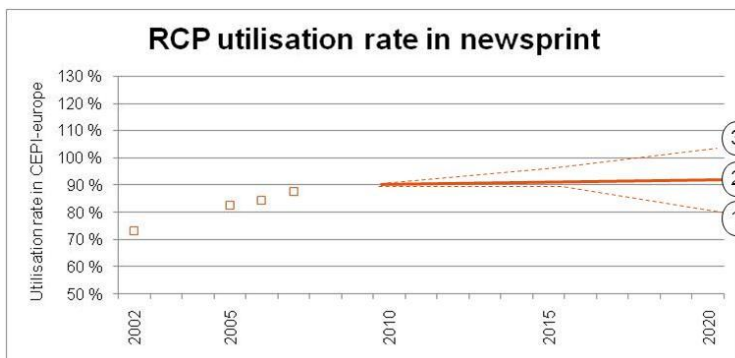

Figure 4.1. Historical and anticipated development of utilisation-rate of RCP in mfg. of newsprint by the panelists. Solid line (#2) represents the median opinion and dotted lines (#1 and #3) represent the extremes.

Please indicate which of the trends (1/2/3) is closest to your view of future development: _____

Nb: in case none of the options represents your opinion accurately enough, please detail how you foresee the development: _____

⁴ CEPI statistics cover countries that are members in CEPI, i.e. AU, BE, CZ, DK, FI, FR, DE, HU, IR, IT, NE, NO, POL, POR, SLO, SP, SWE, SUI, UK. CEPI countries' share of European paper consumption and production averages >90% of total geographical Europe (including non CEPI-members, also Russia).

Key arguments in favor of continued growth of uti-rate in newsprint: <i>Please indicate, which of these statements you tend to agree with and which you don't. Please also specify why. This is especially important if you disagree with a given argument.</i>	Tend to agree: YES / NO
<ul style="list-style-type: none"> • Cost advantage over virgin fibre (TMP) remains. TMP cost are under pressure due to increasing cost of electricity and pulpwood. There will be scarcity of pulpwood in Central Europe. (Why?: _____) 	
<ul style="list-style-type: none"> • Despite growth in RCP utilisation rate, virgin fibre keeps entering the loop in form of OMG, i.e. magazines that still have majority of virgin fibre. (Why?: _____) 	
<ul style="list-style-type: none"> • Recent evidence are the investment decisions of Palm King's Lynn in UK and Perlen Papier in Switzerland. (Why?: _____) 	
<ul style="list-style-type: none"> • RCP yields will decrease which will have an impact on utilisation rates. (As more RCP is required to produce same amount of product!) (Why?: _____) 	
<ul style="list-style-type: none"> • Collection rates are still improving thus creating room for growth in uti-rates (i.e. the market is mainly supply driven). (Why?: _____) 	

Key arguments in favor of saturation or decline of uti-rate in newsprint: <i>Please indicate, which of these statements you tend to agree with and which you don't. Please also specify why. This is especially important if you disagree with a given argument.</i>	Tend to agree: YES / NO
<ul style="list-style-type: none"> • RCP prices are on clearly increasing trend as a result of tightening supply. Main reason behind tightening supply include continued growth of utilisation on both local and export markets. (Why?: _____) 	
<ul style="list-style-type: none"> • Growth potential in RCP collection is small and will be the limiting factor in the growth of utilisation. (Why?: _____) 	
<ul style="list-style-type: none"> • Quality of furnish will gradually decrease and set up a limitation on uti-rate increase in newsprint. As a consequence virgin fibre news will re-appear as a premium product. (Why?: _____) 	
<ul style="list-style-type: none"> • Share of virgin fibre must globally remain on 20-25% in perfect system. (Why?: _____) 	
<ul style="list-style-type: none"> • First investment decisions in virgin fibre are made Sweden (Holmen TMP) as supply of RCP has become too tight. (Why?: _____) 	
<ul style="list-style-type: none"> • An amount of virgin fibre based capacity will remain competitive in Scandinavia and in Russia because of reasonable cost structure. (Why?: _____) 	

4.1.3 RCP utilisation rate in manufacturing of containerboard

Manufacturing of containerboards represents the dominant end use of OCC/MW grades. The history figures in the below chart are from CEPI and they thus cover the CEPI-members. Several panelists saw very similar arguments behind utilisation development in containerboards and in newsprint.

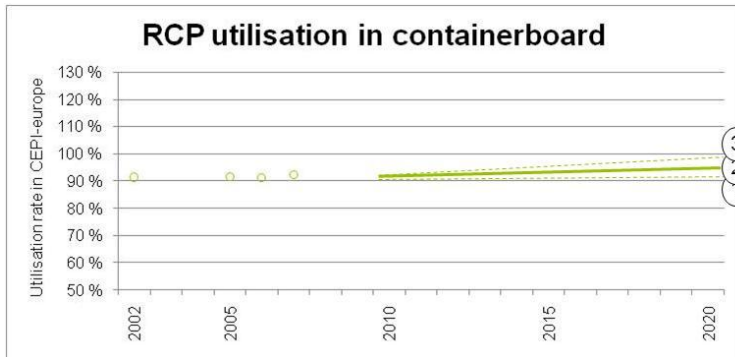

Figure 4.2. Historical and anticipated development of utilisation-rate of RCP in mfg. of containerboard by the panelists. Solid line (#2) represents the median opinion and dotted lines (#1 and #3) represent the extremes.

Please indicate which of the trends (1/2/3) is closest to your view of future development:_____

Nb: in case none of the options represents your opinion accurately enough, please detail how you foresee the development:_____

Key arguments in favor of continued growth of uti-rate in containerboards: <i>Please indicate, which of these statements you tend to agree with and which you don't. Please also specify why. This is especially important if you disagree with a given argument.</i>	Tend to agree: YES / NO
<ul style="list-style-type: none"> • Clear cost advantage over virgin fibre (pulp) remains. (Why?: _____) 	
<ul style="list-style-type: none"> • Recent evidence are the investment decisions of Propapier Eisenhüttenstadt in Germany, Mondi Swiecie in Poland and SAICA in UK. (Why?: _____) 	
<ul style="list-style-type: none"> • RCP yields will decrease which will have an impact on utilisation rates. (As more RCP is required to produce same amount of product!) (Why?: _____) 	
<ul style="list-style-type: none"> • Collection rates are still improving thus creating room for growth in uti-rates (i.e. the market is mainly supply driven). (Why?: _____) 	

Key arguments in favor of saturation or decline of uti-rate in containerboards: <i>Please indicate, which of these statements you tend to agree with and which you don't. Please also specify why. This is especially important if you disagree with a given argument.</i>	Tend to agree: YES / NO
<ul style="list-style-type: none"> • RCP prices are on clearly increasing trend as a result of tightening supply. Main reason behind tightening supply include continued growth of utilisation on both local and export markets. (Why?: _____) 	
<ul style="list-style-type: none"> • Growth potential in RCP collection is small and will be the limiting factor in the growth of utilisation. (Why?: _____) 	
<ul style="list-style-type: none"> • Kraft will keep its position due properties not attainable with RCF. (Why?: _____) 	
<ul style="list-style-type: none"> • Share of virgin fibre must globally remain on 20-25% in perfect system. (Why?: _____) 	

20.9.2010

4.2 Substitute price development

4.2.1 Summary

Following main observations represents the summary of all observations brought up in the 1st round interviews. Behind the links can be found detailed elaboration from the interview memos (Appendix 1).

1. The substitution impact between recycled and virgin fibre is limited in short term but becomes clear in long term. [Quotes](#)
2. Price of pulpwood and wood in general is on a rising trend because it is renewable. The CO2-benefits and other taxation effects will come on top of that basic fact. [Quotes](#)
3. Development of energy price has a double impact in demand of RCF a) through mfg cost of virgin fibre and b) through fuel value of wood. [Quotes](#)
4. In long term the investments in plantation forests in the southern hemisphere and improving economies of scale in chemical pulping will keep the pulp price either declining or only moderately increasing. [Quotes](#)

Do you in general agree with the summary presented above? _____ (YES/NO)

Please, feel free to elaborate your viewpoints on the above:

4.2.2 Development of pulpwood price

The substitute of RCF in the European newsprint market is in long term Nordic and Russian TMP made of Spruce. Historical price trend of pulpwood of spruce in Sweden is readily available and thereby used here for discussion purposes. (Source SDC; Swedish Forest Agency, Analysis Department)

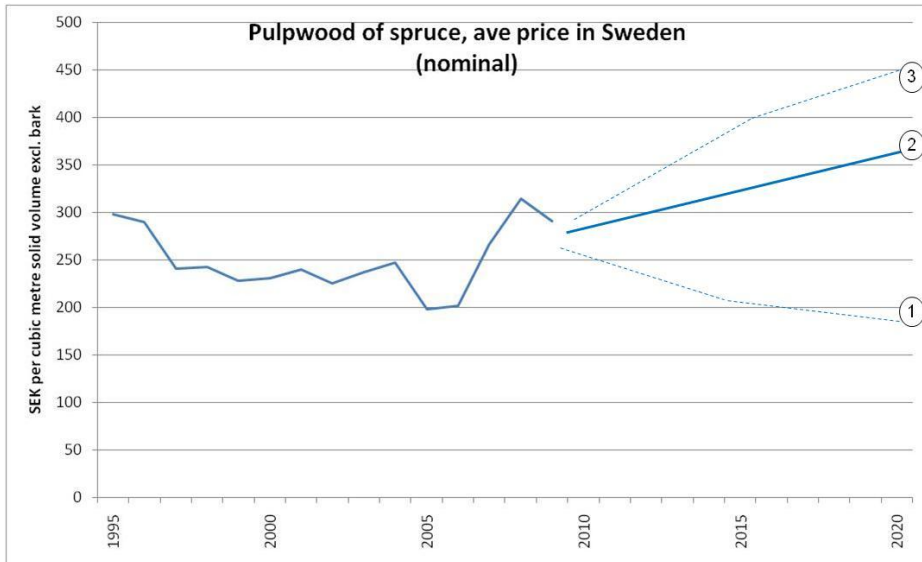

Figure 4.3. Historical and anticipated development of pulpwood price (spruce in Sweden). Solid line (#2) represents the median opinion and dotted lines (#1 and #3) represent the extremes.

Please indicate which of the trends (1/2/3) is closest to your view of future development: _____

Nb: in case none of the options represents your opinion accurately enough, please detail how you foresee the development: _____

Key arguments in favor of growth in pulpwood prices: <i>Please indicate, which of these statements you tend to agree with and which you don't. Please also specify why. This is especially important if you disagree with a given argument.</i>	Tend to agree: YES / NO
<ul style="list-style-type: none"> General competition for biomass for fuel and energy use will push also the pulpwood prices up. (Why?: _____) 	
<ul style="list-style-type: none"> Cultivation projects of fast growing biomass for fuel use are being planned. (Why?: _____) 	
<ul style="list-style-type: none"> Suitable land area is or will become limited and price of forest area will increase as well thus pushing the wood price up. (Why?: _____) 	
<ul style="list-style-type: none"> There are increasing subsidies on energy use of biomass. (Why?: _____) 	
<ul style="list-style-type: none"> The forest owners will welcome the good side revenue from energy wood and will actively work for it thus working in favor of development of fuelwood market. (Why?: _____) 	
<ul style="list-style-type: none"> Structure of forest ownership is further fragmenting which makes it less attractive for forest owners to make fellings thus reducing supply. (Why?: _____) 	
<ul style="list-style-type: none"> Strong northern fibre will be needed in paper products in future as well. Also new purposes for Nordic soft wood may emerge. There is ultimately paying capacity for the good fibre, i.e. demand as pulpwood is less elastic as anticipated. (Why?: _____) 	
<ul style="list-style-type: none"> TMP might stop losing market share as RCP supply becomes tighter and prices increase. (Why?: _____) 	

Key arguments in favor of saturation or decline in pulpwood prices: <i>Please indicate, which of these statements you tend to agree with and which you don't. Please also specify why. This is especially important if you disagree with a given argument.</i>	Tend to agree: YES / NO
<ul style="list-style-type: none"> • There is significant elasticity in pulpwood demand. I.e. pulpwood demand in fibre use will decrease if prices increased a lot. (Why?: _____) 	
<ul style="list-style-type: none"> • Demand will grow modestly if at all. E.g. rising electricity prices will curtail pulpwood demand for TMP. (Why?: _____) 	
<ul style="list-style-type: none"> • Increasing energy use will be balanced out by decrease in paper production. (Why?: _____) 	
<ul style="list-style-type: none"> • In Nordic the fuel use is small in comparison to fibre use. Therefore fuel price has little impact. The situation is completely different in Central Europe where fuel use is more significant. (Why?: _____) 	
<ul style="list-style-type: none"> • Society can't afford the large scale fuel use of pulp wood. The required subsidies would be substantial – on top of the reduction in the output of various forest products. (Why?: _____) 	
<ul style="list-style-type: none"> • Ample availability of short fibre from Southern hemisphere will reduce pulpwood demand in Nordic countries. (Why?: _____) 	
<ul style="list-style-type: none"> • Swedish production cost structure is favorable for TMP. A lot of hydro and nuclear power together with ample CO2 credits will keep electricity prices reasonable. Paper mills are also quite self sufficient in resources. (Why?: _____) 	

4.2.3 Development of electricity price

Electricity cost represents a major share of TMP manufactured cost and its specific consumption is roughly ten-fold to that of DIP. Therefore development of electricity price has an obvious impact on relative competitiveness of DIP vs TMP. Historical price trend of electricity in Scandinavia is readily available and thereby used here for discussion purposes. (Source Nordpool)

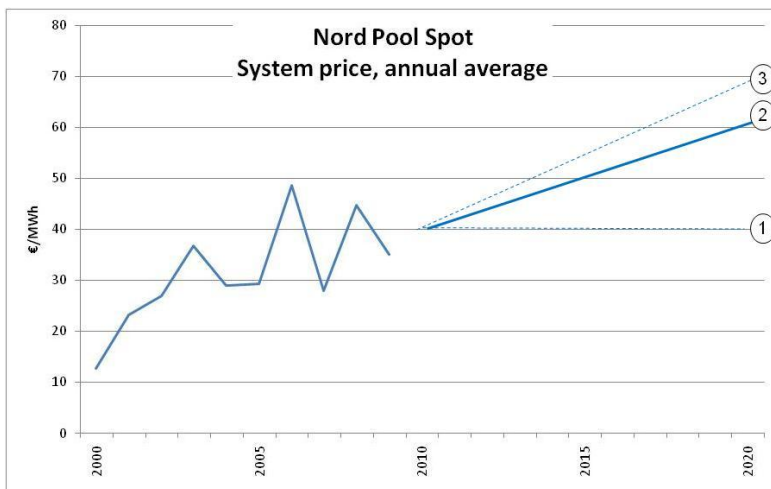

Figure 4.4. Historical and anticipated development of electricity (Nordpool spot, annual average). Solid line (#2) represents the median opinion and dotted lines (#1 and #3) represent the extremes.

Please indicate which of the trends (1/2/3) is closest to your view of future development: _____

Nb: in case none of the options represents your opinion accurately enough, please detail how you foresee the development: _____

Key arguments in favor of growth in electricity price: <i>Please indicate, which of these statements you tend to agree with and which you don't. Please also specify why. This is especially important if you disagree with a given argument.</i>	Tend to agree: YES / NO
<ul style="list-style-type: none"> • There are major investments (and plans) in electricity production capacity in Nordic. If exports and consequent transfer capacity were politically accepted and built, increase in prices to Central European level would be witnessed. (Why?: _____) 	
<ul style="list-style-type: none"> • Electricity consumption will continue to grow. Eventually in transportation as well. (Why?: _____) 	
<ul style="list-style-type: none"> • New capacity will increase the prices due heavy investments and Carbon Capture obligations. Impact of the later has been estimated to be +50 €/MWh in coal fired condensate. (Why?: _____) 	
<ul style="list-style-type: none"> • Energy taxation (in its different forms) will further increase the prices. (Why?: _____) 	
<ul style="list-style-type: none"> • Photovoltaics and renewable energy will call for rather high price level in order to develop. There is political will to ensure their development. (Why?: _____) 	

Key arguments in favor of saturation or only slight growth in electricity price: <i>Please indicate, which of these statements you tend to agree with and which you don't. Please also specify why. This is especially important if you disagree with a given argument.</i>	Tend to agree: YES / NO
<ul style="list-style-type: none"> • A drop in demand is foreseen as major closures of mechanical pulping capacity are expected in time frame up to 2020. Also other industrial consumption in Nordic might turn into decline. (Why?: _____) 	
<ul style="list-style-type: none"> • New investments in nuclear power plant capacity will prevent large price increases. (Why?: _____) 	
<ul style="list-style-type: none"> • If the unification of European electricity markets will not take place, electricity price is likely to stay flat (based on development of local demand / supply balance in the Nordic market). (Why?: _____) 	

4.2.4 Development of pulp price

The ultimate substitute of RCF is chemical pulp. In manufacturing of several paper and board grades kraft pulp remains a component that brings such functionality that is more difficult to achieve with RCF. Manufacturing corrugated case materials out of 100% OCC vs. mixing in a portion of unbleached kraft pulp serves as one example in this respect. Nordic bleached softwood kraft has well documented price history and is here used to reflect general price development of long fibre virgin pulp (Source FOEX/Metso).

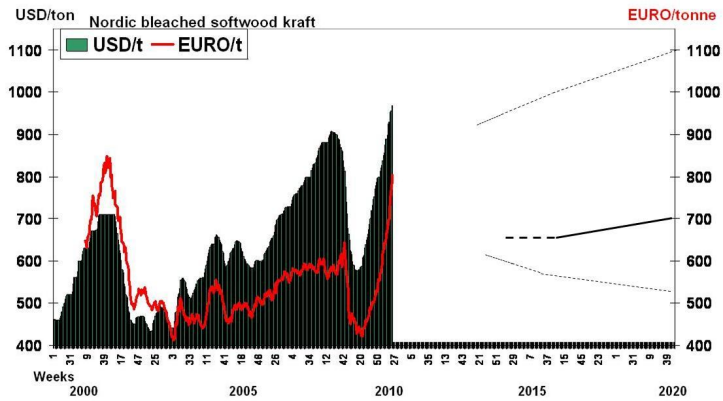

Figure 4.5. Historical and anticipated price development of bleached softwood kraft pulp. Solid line (#2) represents the median opinion and dotted lines (#1 and #3) represent the extremes.

Please indicate which of the trends (1/2/3) is closest to your view of future development: _____

Nb: in case none of the options represents your opinion accurately enough, please detail how you foresee the development: _____

Note: Here panelists had really big spread of opinions ranging from decreasing price trend to prices maintaining their present, historically very high level.

<p>Key arguments in favor of increasing pulp prices: <i>Please indicate, which of these statements you tend to agree with and which you don't. Please also specify why. This is especially important if you disagree with a given argument.</i></p>	<p>Tend to agree: YES / NO</p>
<ul style="list-style-type: none"> The general competition for biomass will keep also the pulp prices relatively on a higher level. E.g. use of fuel wood will increase thus tightening the supply. It also means that the long-term historical price trend of decreasing pulp prices will come to an end. (Why?: _____) 	
<ul style="list-style-type: none"> Significant share of RCF is used as biofuel in some form. (Why?: _____) 	
<ul style="list-style-type: none"> Increase in fibre based packaging will keep demand on a growth track. (Why?: _____) 	
<ul style="list-style-type: none"> Reinforcement pulp will be needed in future as well. Thus no decline in demand. (Why?: _____) 	
<ul style="list-style-type: none"> Pulp lives in connection to other raw materials, thus a rising trend. (Why?: _____) 	

<p>Key arguments in favor of flat or decreasing pulp prices: <i>Please indicate, which of these statements you tend to agree with and which you don't. Please also specify why. This is especially important if you disagree with a given argument.</i></p>	<p>Tend to agree: YES / NO</p>
<ul style="list-style-type: none"> • Increase in low cost pulping capacity in southern hemisphere (low raw material cost and economy of scale; also logistics will keep improving). Also hardwood will keep increasing its market share over softwood. (Why?: _____) 	
<ul style="list-style-type: none"> • The demand in long term is not increasing that much. I.e. increasing the chemical pulp supply has no difficulties to match the increases in demand. Market behaves very logically, following changes in demand, supply and inventories. (Why?: _____) 	
<ul style="list-style-type: none"> • Hardwood price will decrease due plantations and economy of scale - the price gap between HW/SW will probably grow. (Why?: _____) 	
<ul style="list-style-type: none"> • Demand in long term will decline. (Why?: _____) 	

20.9.2010

4.3 Development of RCP supply

4.3.1 Summary

Following main observations represents the summary of all observations brought up in the 1st round interviews. Behind the links can be found detailed elaboration from the interview memos (Appendix 1).

1. Though there remains both political and demand pressure to increase the collection rates they are estimated to saturate soon. Some 5-10%, in maximum, is attainable on global scale. [Quotes](#)
[Quotes \(on role of legislation\)](#)
2. Development of collection systems towards commingled collection will increase the supply of mixed grades, thus bringing further difficulties to manufacturers of graphic grades. [Quotes](#)
3. Development of collection systems will bring more flexibility for the operators to optimise between fuel and fibre market. This is likely to create conflicts of interest between collection operators and paper industry. [Quotes](#)

Do you in general agree with the summary presented above? _____ (YES/NO)

Please, feel free to elaborate your viewpoints on the above:

4.3.2 Development of collection rate

The collection rate of RCP is directly reflecting the supply development of RCF for papermaking. Development of overall collection rate in Europe is here used as the best available indication of supply development (Source of historical data: CEPI). Grade and collection system specific information is not available.

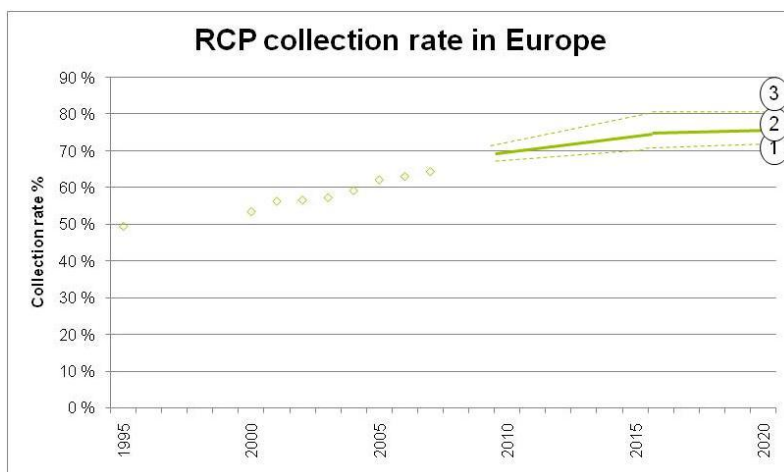

Figure 4.6. Historical and anticipated development of RCP collection rate in Europe. Solid line (#2) represents the median opinion and dotted lines (#1 and #3) represent the extremes.

Please indicate which of the trends (1/2/3) is closest to your view of future development: _____

Nb: in case none of the options represents your opinion accurately enough, please detail how you foresee the development: _____

Key arguments in favor of strong/fair growth in collection rate: <i>Please indicate, which of these statements you tend to agree with and which you don't. Please also specify why. This is especially important if you disagree with a given argument.</i>	Tend to agree: YES / NO
<ul style="list-style-type: none"> Collection rates keep still improving as higher and higher mandatory requirements are set by authorities. (Why?: _____) 	
<ul style="list-style-type: none"> High price level of RCP creates an incentive to sort and improve collection systems. (Why?: _____) 	
<ul style="list-style-type: none"> People have genuine interest to sort their wastes thereby gradually increasing the collection. (Why?: _____) 	
<ul style="list-style-type: none"> Collection systems keep improving (bin at homeyard increases sorting-%) (Why?: _____) 	
<ul style="list-style-type: none"> China's demand will keep pulling EU supply. (Why?: _____) 	
<ul style="list-style-type: none"> New countries will step-up their systems to Western European standards. (Why?: _____) 	

Key arguments in favor of rapid saturation in collection rate: <i>Please indicate, which of these statements you tend to agree with and which you don't. Please also specify why. This is especially important if you disagree with a given argument.</i>	Tend to agree: YES / NO
<ul style="list-style-type: none"> • The potential simply is not that high anymore and natural, rational maximum level will be soon reached. (Why?: _____) 	
<ul style="list-style-type: none"> • Technical maximum is reached soon (already 2015). (Why?: _____) 	
<ul style="list-style-type: none"> • In many EU countries there is slow development (e.g. FR, IT, Eastern Europe) (Why?: _____) 	
<ul style="list-style-type: none"> • Almost all remaining potential lies with household collection. It is however expensive to expand into rural areas. (Why?: _____) 	
<ul style="list-style-type: none"> • As sophisticated collection systems like in Germany will not be built anymore. (Why?: _____) 	
<ul style="list-style-type: none"> • Energy use, i.e. co-combustion is eating up some of the growth potential. (Why?: _____) 	

20.9.2010

4.4 Market development related to energy utilisation of RCF

4.4.1 Summary

1. Based on the current and forecasted price difference of RCP and different bio-fuels, there is very small risk that standard RCP grades would go into fuel use in West Europe. [Quotes](#)
2. There is a clear trend of building waste-to-energy power plants at paper mill sites and for certain other industrial uses. As increasing use of waste-to-energy will eat up some of the future growth potential from RCP supply, this trend will have at least indirect impact in prices and quantities of RCP. [Quotes](#), [More quotes](#)
3. Strong political push behind renewable energy and biomass in particular will cause at least a small disturbance on the RCP market (e.g. in form of CO2-credit benefits). [Quotes](#)
4. Technical development in waste-to-energy (and biomass based energy in general) remains a wild card in future speculations. There are arguments and opinions for and against of it having a big impact. [Quotes](#), [More quotes](#)

Do you in general agree with the summary presented above? _____ (YES/NO)

Please, feel free to elaborate your viewpoints on the above:

4.4.2 Price development in CO2-trade

RCF content in waste flows is generally regarded CO2 neutral and a power plant does not need to consume any CO2 credits for the renewable share of its fuel mix. Therefore the price of RCP and other RCF containing waste flows in the fuel market could in future benefit from the high price of CO2-credits. EU target is to reduce CO2 emissions by 20% in next ten years. This means that the industry, at least in theory, will be rewarded less and less credits each year and their price should consequently increase - unless their demand at the same time proportionally decreased. E.g. as a result of increasing use of renewable fuels.

To date, there is little historical experience of price behavior of CO2 credits. Price has mainly stayed between 10-15 €/t during the current trading period.

The majority of panelists believed that price level of CO2-credits will increase to a rather high level, 30-35 €/t, and even up to 50 €/t by 2020. Some predicted fairly stable level of 20 €/t to last for the whole decade. A couple of panelists considered that the whole system might collapse or radically change by 2020.

Any new comments on the predicted CO2-credit price level: _____

Key arguments in favor of high price level of CO2-credits: <i>Please indicate, which of these statements you tend to agree with and which you don't. Please also specify why. This is especially important if you disagree with a given argument.</i>	Tend to agree: YES / NO
<ul style="list-style-type: none"> It is a prevailing expert opinion of the market development. E.g. IEA has predicted a price level around 50 \$/t in 2020. (IEA World Energy Outlook, 2009) (Why?: _____) 	
<ul style="list-style-type: none"> -20% target in EU's CO2-emissions calls for rather high price level. (Why?: _____) 	
<ul style="list-style-type: none"> Global cap&trade actions are likely after 2015 and they will push the price level up. (Why?: _____) 	

20.9.2010

Key arguments in favor of low price level of CO2-credits: <i>Please indicate, which of these statements you tend to agree with and which you don't. Please also specify why. This is especially important if you disagree with a given argument.</i>	Tend to agree: YES / NO
<ul style="list-style-type: none">• EU target of -20% is very speculative. Credits are dealt out generously at the moment. (Why?: _____)	
<ul style="list-style-type: none">• Political pressure, i.e. weak economy and "carbon escape" (industry escaping Europe) will keep the price level low. (Why?: _____)	

4.4.3 Price development of transportation fuels

One of the areas where there are a lot of expectations to increase the share of renewables are the transportation fuels. Majority of oil is today consumed by transportation and the western economies are actively searching means to reduce their carbon emissions in traffic and at the same time to reduce their dependence on oil imports.

Increasing prices of transportation fuels also create room for investments in production of Ethanol and Diesel from biomass. RCP and other RCF containing wastes are in theory potential feedstocks in such processes and therefore price development of transportation fuels may also have importance for RCF market.

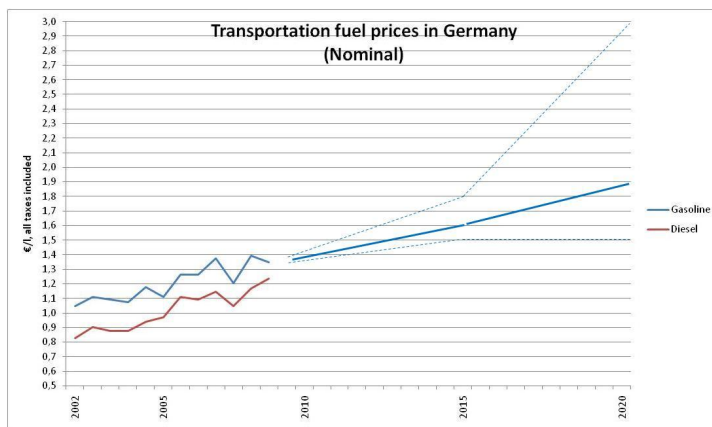

Figure 4.7. Historical and anticipated development of transportation fuel prices in Germany (Source Eurostat) . Solid line (#2) represents the median opinion and dotted lines (#1 and #3) represent the extremes.

Please indicate which of the trends (1/2/3) is closest to your view of future development: _____

Nb: in case none of the options represents your opinion accurately enough, please detail how you foresee the development: _____

Key arguments in favor of strong growth in fuel prices: <i>Please indicate, which of these statements you tend to agree with and which you don't. Please also specify why. This is especially important if you disagree with a given argument.</i>	Tend to agree: YES / NO
<ul style="list-style-type: none"> There are limited reserves of oil, i.e. peak oil is either at hand or has already passed. (Why?: _____) 	
<ul style="list-style-type: none"> Demand development in Asia, particularly China, is too strong to be met by supply. Chinese already buy more cars than US but the difference is that the whole amount is absolute growth in China whereas in US roughly same amount of cars are scrapped as purchased. The effect of increasing motoring in China will be huge. (Why?: _____) 	
<ul style="list-style-type: none"> Oil demand in electricity generation keeps high as diesel power plants are the least risky investment in many politically unstable societies. (Why?: _____) 	
<ul style="list-style-type: none"> There is very high paying capacity in western countries. E.g. 3 €/l level is still affordable if your modern car runs with 4 l/100 km. (12 c/km fuel cost) (Why?: _____) 	
<ul style="list-style-type: none"> States need environmental taxes. (Why?: _____) 	
<ul style="list-style-type: none"> Bio-component is made mandatory and that increases the cost level. (Why?: _____) 	
<ul style="list-style-type: none"> High price level serves the political target of curtailing the oil consumption. (Why?: _____) 	

20.9.2010

<p>Key arguments in favor of only moderate growth in fuel prices: <i>Please indicate, which of these statements you tend to agree with and which you don't. Please also specify why. This is especially important if you disagree with a given argument.</i></p>	<p>Tend to agree: YES / NO</p>
<ul style="list-style-type: none"> • Peak oil will not be encountered by 2020. (Why?: _____) 	
<ul style="list-style-type: none"> • It is not in oil producers interests to ruin the present healthy demand by very high price level. They will keep increasing the supply. (Why?: _____) 	
<ul style="list-style-type: none"> • Macro-economic importance of transportation cost holds diesel down. (Why?: _____) 	
<ul style="list-style-type: none"> • Fuel consumption of cars is decreasing rapidly. (Why?: _____) 	
<ul style="list-style-type: none"> • There is strong consumer resistance against increase in prices. Consumer opinion holds 2,2€/l level terrible so that it would radically impact consumption. (Why?: _____) 	
<ul style="list-style-type: none"> • Alternative fuels and electricity will increase their share. (Why?: _____) 	

20.9.2010

APPENDICES

20.9.2010

APPENDIX I KEY COMMENTARY FROM THE OPEN-ENDED DISCUSSIONS OF THE 1ST INTERVIEWS

This Appendix presents the market observations that interviewees brought up in the open-ended discussions of the 1st round interviews. The observations are here grouped under following main factors and further under several sub-themes within each main factor:

- 1) Demand development of RCF at paper mills
- 2) Substitute price development
- 3) Supply development, i.e. development of RCP collection rate
- 4) Market development related to utilisation of RCF as energy

The observations are mainly repeated in the form they were put up in the summarising minutes that the author wrote based on each discussion (good old copy-paste method!). Several observations repeatedly came up in the interviews but are presented in this report only once. However, sometimes there was slightly different wording or perspective to the same topic and therefore some overlapping comments are left in the report.

All summarising minutes were also reviewed by the interviewees and corrected based on their feedback.

20.9.2010

I.i Demand development of RCF at paper mills (= RCP utilisation rate)

I.i.i General direction of demand development [Back](#)

Very common opinion among panelists held that RCF will keep winning market share:

Growth in utilisation of RCP will continue. RCP is a good and affordable raw material and there's only slight difference in end product quality.

Utilisation of RCF also provides an "environmental image".

It seems that demand is still developing faster than supply - especially in OCC. This pushes collection up in the nearby developing areas. (Assuming the collection of OCC can't develop that much anymore in Europe.)

RCF keeps increasing its market share among papermaking raw materials, though gradually.

Following factors influencing most the general direction were frequently mentioned:

The aspiration of paper industry is still to increase utilisation of RCP, even if the price level is higher than ever – because it is still the most economical alternative. All graphic papers, even fine paper, have still the possibility to increase RCP utilisation. In packaging sector the RCP already is totally dominant raw material.

The main factor affecting the demand for RCF is its price (in the long term). There are no quality reasons. Indirectly also the substitute price, i.e. the price of virgin fibre has significance.

Another very important factor is that RCF is a workable solution for the geographical area suffering from serious fibre deficit. That is mainly China and India which together represents a consumer base easily exceeding 2 billion inhabitants. Interestingly, also market pulp and even wood chips are technically suitable alternatives to RCF in fulfilling the raw material deficit of this area. Even if the price volatility and occasional availability limitations of RCP are higher than of VF, the choice of investors has been clear. At least 70-75% of investments in new capacity in China and India are based on RCF. This obviously is based on economical benefits, both in capital and operating expenses.

Within developed economies the consumer habits and ways of commerce keep changing in the direction that in general increases the need for [fibre based] packaging materials. In many of these applications, competitiveness of RCF is at its best.

Sometimes also environmental image and various eco-labels are the reason or part of the reason, i.e. pure marketing reasons.

In the past "green thinking" has impacted the popularity of RCF. It means that the general idea of limited resource base directs towards recycling.

20.9.2010

Consumer acceptance is clearly favoring use of RCF. It is generally regarded smart to use RCF. Detailed analysis might reveal different results.

Virgin fibre is always needed in the system (waterwheel analogy, as introduced by Mr. Ilpo Ervasti).

There is actually little flexibility between virgin vs recycled. The decisions are made when the installations are built.

One question regarding future of Supply and Demand of RCF is eventual new uses of fibre-based materials - how much such will emerge? Also different composite structures of recycled plastics and wood products may emerge.

One should not forget that there are also such market drivers that support reduction in the utilisation of RCP. The market of tissue papers is a good example: when GNP grows, the consumption of tissue paper not only grows but also shifts to higher quality virgin fibre based grades. To some extent similar phenomenon exist in packaging.

Global utilisation rate is today around 50% and is estimated to rise to 60% in 10-15 yrs. It is questionable if it can rise any further than that. It is a well known fact that about 20% of the paper consumption is unattainable to recycling.

In the packaging sector there are drivers in favor of increased use of fibre based packaging, mainly for environmental reasons. On the other hand, energy conversion of plastics waste is very efficient and plastics are often advantageously produced as by-product in refineries. As a high-tech substrate (printed RFID, thin disposable displays, nanopipes) plastics is superior to paper.

Market development in Finland, and probably also elsewhere, is that demand of good quality RCP will just further increase. For poorer qualities not. In fact, more and more dirty, miscellaneous streams will come into the sphere of collection.

Demand of Recovered Paper (RCP) is increasing. Sometimes the reason is lack of raw materials [*like in Chinese paper industry*]. On the supply side in Europe there are obligations to further increase the collection rate, also the high price of RCP is stimulating collection at the moment.

Several panelists were in the opinion that the general direction of the market is hard to predict:

It seems that the consumption pattern of paper products is changing a lot (due electronic media, fibre based packaging, etc.).

Whether RCF will continue winning market shares is difficult to predict. To understand this question one has to take a more holistic view of the situation including e.g. utilisation of cellulosic fibres (both virgin and recycled) in energy production.

20.9.2010

RCP market is a global market. It is difficult to make reliable prediction on its development. Especially, the market development in Asia is hard to predict.

On demand outside paper making:

It has been estimated that 5-7% of RCF is utilised outside paper industry: in molded products, as insulation material, animal beddings, etc. If these quantities are included in utilisation statistics varies between countries, mostly they are not included. It is not likely that these uses outside paper industry will grow their share of total utilisation.

The big question remains whether RCF should be re-used in papermaking or burned for energy – other uses of RCF like as insulation material will remain marginal.

[Back](#)

I.i.ii On-going structural development

Following issues or observations came up in the interviews related to capacity closures and new investments:

Capacity closures mainly take place among virgin fibre based mills, even more pronounced so in North America. This causes further tightening of RCP supply. *[This is also a further evidence of RCP's cost competitiveness. Even though the paper makers must see the emerging scarcity and the current price level being more or less standard in future.]*

The few ongoing investments in new capacity in the West are dominantly based on RCP. There are some investments, though, in plantation wood. *[But clearly less than for RCP]*

The big new mills coming on-stream (Eisenhüttenstadt, Swiecie, Saica UK,...) already represent several percentages of total European supply of RCP. In other words their impact on the RCP market will be huge.

Large public corporations have cut their investments in new capacity. Smaller, often private companies keep investing. Mill closures have largely been in Finland, very little in Sweden. *[In Europe this has meant increase in share of RCF]*

Following came up related to structure of paper consumption:

In longer perspective paper consumption is likely to decline. Especially graphical papers. The growth in consumption of transp. packaging will also slow down in Europe as mfg. operations will increasingly take place outside Europe. Even under these conditions the market share of RCF can grow, thus increasing the relative demand of RCF and thereby RCP.

In recent past the consumption of graphic papers has been on decline in the main RCP supply

44

20.9.2010

market of the west. From the perspective of global imbalance in RCP demand, this is a difficult equation. There are a couple of hypothesis / scenarios related to this phenomenon: 1) tight supply of ONP/OMG is partly created by increased share of MW (a mixture of OCC and ONP/OMG grades), 2) single stream and commingled collection will improve the supply of household collected grades (thus balancing the hypothesis 1 ??) The market of OW has behaved quite similar to graphic papers. There is a decline on the main supplying market and a strengthening offshore demand.

Bleed of ONP/OMG to the packaging side is also a reality. This will create further scarcity in ONP/OMG supply.

If paper consumption in absolute terms turned into a decline, the companies operating existing strong assets in pulp production might become tempted to continue running those up to the full capacity even if the demand was in decline. *[In other words, the market share would be acquired by lower prices, which in turn might divert part of the RCF potential into energy use. In fact, also pulp mills have some flexibility to increase electricity production at the cost of pulp yield. This flexibility, however, would be quickly eaten up. Also, this scenario assumes that low cost pulp wood continues to be in ample supply.]*

The paper mills have emerged close to the consuming market and the RCF supplies, i.e. the idea of "urban mill".

I.i.iii Factors affecting the short term demand, ie. daily balance of Supply & Demand [Back](#)

Operating rate was frequently mentioned as the main short term factor dictating the level of demand:

Operating rate of the paper industry is the most significant factor. In normal conditions it is, however, pretty stable. Most of the time 90±5%.

The economic cycle also impacts the demand / supply balance through paper consumption. E.g. currently there is a major scarcity of RCP in Europe. Since March 2010 for the first time in history, paper mills have been stopped due to lack of RCP. The reason for the tight supply at the moment is of course the exports to Asia but momentarily also the decline in paper consumption that has caused fewer and fewer paper entering into collection.

The following comments were made on the **impact of price** on RCF demand:

Price of recovered paper has very little effect on the demand. Utilisation capacity is fixed, warehouse capacity is more or less fixed. If demand by paper mills decreases, however, drops the price quickly. Changes in supply can increase the price as well.

170 €/t is probably the long term average price level for both main grades (2025).

20.9.2010

The price gap between OCC/MW and ONP/OMG should be 30-40 €/t to ensure availability of ONP. Otherwise much of the household collection will be sold as MW.

In some of the previous research, the **inventory levels** have been identified as the main short-term factor affecting the price development. (Huttunen, 1996). Similar observation was raised up several times by the panelists, e.g.:

Inventory capacities at paper mills are really small, around one week for ONP/OMG users. For OCC the situation is somewhat different as the quality tolerates warehousing outside.

Contracts balance the need for warehouse capacity. There are frame agreements for RCP purchases up to 5 yrs with certain in-built price correction mechanisms. Shorter agreements are only for 1 month deliveries. On top of that there is pure spot trade. There was practically no possibility to utilise the very low short term price levels encountered at the end of 2008 due non-existing warehouse capacity.

Volatility of RCP is very high and higher than for virgin fibre. As long-term trend the inventories are on the downward trend. Combined with increasing demand it will further increase the volatility.

Price trends of RCP are probably following the ones of paper, especially printing paper. The market is very speculative as the RCP is relatively easy to warehouse. There is clear analogy to fine paper market where the merchants have a big role in price speculation.

Other observations mentioned in connection to the short term factors affecting level of demand:

One particular difficulty for the producers of graphic papers is that the price cycles of end products and RCP are not in synchronicity as is the case in the packaging sector. It even seems that the graphic paper prices are lowest when the RCP is in tight supply. [*This can be explained by the fact that graphic paper prices are high when their demand is high, which in turn causes more and more RCP to enter the system thus easing the RCP supply and lowering its prices. In the opposite cycle, the opposite happens.*] The graphic paper sector has found it impossible to transfer the increasing RCP cost into prices as the sector uses all three main raw material components pulp, mechanical pulp and RCP.

On the brown side it appears that price of testliner is following directly the changes in RCP price. The margin might even grow by increasing RCP price. Brown side probably has ultimately more paying capacity for RCP than graphic side as packaging is such a minor share in the consumer price of most products. [*In comparison, paper cost is quite significant for publishers.*]

VF supply has higher price elasticity than RCF, especially when capacity utilisation rates are high. Most pulp mills usually operate below maximum operating rates and are able to stretch their output by increased demand. Obviously in long term the flexibility is brought by new capital investments. (Though the leadtimes are long, easily 24 months) Also the inventory capacity is higher in VF.

20.9.2010

Main driver of price changes is the export demand from China. Still it is difficult to understand the jumping changes in prices. Maybe someone is by purpose aiming at creating turbulence and big changes in prices. Someone is benefiting from that. Could be even criminal interests, money laundering etc. involved.

Overall perception of the short-term market development was that a tight supply is likely to continue:

Current tight supply of RCP will be long term and prices will remain high. Though there will be cyclical changes on a high level driven by Chinese stock building. A global economical downturn will lead to remarkable drop in prices.

[Back](#)

I.i.iv "China-factor" [Back](#)

Looking at the overall statistics of collection and utilisation in different market areas (Appendix 1) it becomes apparent, that the impact of the **Chinese market is decisive** in RCF demand. The same development as experienced in 2000's has continued also since 2007. This was well reflected in the interviews, where following observations were brought up related to the "China factor". [Back](#)

The Impact of China and local investments in market is huge. Over investments have created pressure to export paper products made of imported recovered paper.

In the past Chinese buyers were purchasing from NA and EU by turns. This way they exploited the market volatility.

China's share in demand is so big that if radical downturn happens there, the recovered paper will remain on merchants hands and the price will drop negative.

China's impact on the market is huge and quantities will only grow. It is not alone, though. There are many others importing significant quantities such as India who is eager to do a lot of the sorting by themselves as the labor is very cheap in India. A little bit the same applies to China.

No-one really knows the Chinese cost structure in RCP business.

Main driver setting the RCP price level is the paying capacity of Chinese containerboard mills. *[It appears that the paying capacity lies at least at 200-250 \$/t. If \$ reached par with €, this would mean up to 200 €/t free at European port.]*

The apparently very good paying capability of Chinese paper mills for RCP is very logical. Chinese factories can't ultimately do without packaging their goods. *[As Chinese industry producing consumer goods is very price competitive, there is as a consequence very little elasticity in chinese RCP demand for packaging purposes].*

The reason why Chinese have invested in RCP-based capacity is naturally their lack of raw materials (virgin fibre more expensive to import than RCP).

20.9.2010

Paper production in NA and EU is stagnating. All investments are capacity replacements. China on the other hand is estimated to invest 7-8 Mt/a new capacity for the next 10 years but continues to lack the raw materials.

The currency rate has big impact in RCP demand in Europe. Now when Euro is becoming weaker, the Chinese have more and more paying capability for European flows. On the other hand the weak Euro is protecting the industry from imports of paper. Also the freight cost is very important: e.g. in news >30% of east to west delivered cost consists of freight.

OCC/ONP gap will diminish. Already today Chinese import prices are about the same. OCC to China is the driver to close the gap.

The global market is clearly "China-driven". It appears a permanent situation. ... even if expansion of manufacturing operations in China slowed down there will emerge new countries with ample low cost work force and consequently growing need of packaging, most likely to be made of [*imported*] RCP.

China is setting the marginal price of RCP.

The higher price level of RCP on the Chinese market (e.g. free, Shanghai) is explained by transportation cost, duties and inspection fees and the margin of the traders.

Another reason behind the popularity of RCF in Asia has been the high price of electricity. It has somewhat strengthened the operating cost advantage of RCF over mechanical pulps.

Demand growth in "China" (here including also India) is and will continue to be a significant part of global fibre balance. There are a couple of noteworthy issues: 1) China is implementing legislation that forces the closure of large number of small straw pulp utilising paper mills (<34 kt/a) for effluent and chemicals recovery related reasons. This removes 2-4 Mt/a of short fibre from the market. This can be replaced either by RCP or BHKP. Both will be needed as the straw pulp has been used mainly in local fluting and in "yellow straw board". Replacement will probably be 50/50. 2) The collection of RCP in China is not on as high level as in EU or US. There is certain bias in the statistics (5-10 %-units due exports with goods), but nevertheless there are restrictions in the chinese collection systems, e.g. in logistics and also by other competing end uses such as packaging material use of waste paper, use as insulation materials and use as fuel in households.

Continuing urbanisation and growth in the standard of living may also favor virgin fibre as printed magazines are regarded somewhat luxury in China. Probably RCP continues to have bigger role in packaging.

For some reason the cost of return sea freight has increased significantly. There are no more "free rides" back to China. This has increased the cost difference of RCP between EU and China.

20.9.2010

China obviously has a huge impact on the market. It is unclear, though, how long the present development in China continues. China has exercised very merchantilistic policy and has kept stockpiling the wealth instead of spreading it to the people. This may come to an end soon as the standard of living keeps increasing (at least pressures to increase it) and natural resources become more and more competed for. This includes mineral resources, biomass and foodstuff.

[Back](#)

I.i.v Development of technology

Technical development has in the past played a major role in enabling paper makers to increase RCF content in their furnish mix and has also helped to do so in more and more economical fashion. Thus technical development has played a significant role in demand development. Most of the panelists did have little specialist know-how in the technical side of the topic, but still a few comments were brought up: [Back](#)

Technology development in utilisation will continue. Yield and quality of furnish will keep improving thanks to developments in deinking, fractionation, multiply-structures, sizing, etc.

Technical development should aim at improving recyclability of paper products. E.g. the issue of flexo inks.

Papermills will be able to reach the same quality as before from poorer and poorer raw materials.

Maybe the cap of collection rate is finally found when the quality of fibre becomes the limiting factor.

It seems that RCF yield out of RCP is decreasing 1% each year. This means more reject, more sludge, more ash, year by year. [Note: another respondent mentined that the amount of ash is saturating in RCP.]

There are improvements expected in RCP processing technology. E.g. better washing will improve PM runnability. Process will also be moretolerant for flexo content (up to 15-20% in std news).

On the front of technical development there are advances improving the yield. A big question mark is how the filler content in sludges can be utilised.

One clear reason in increased demand for RCF is the technical development in utilisation. These include multi-ply concepts and various advances in paper machines. Earlier, there was a speed limitation associated with RCF. In the early 90's a break-through was made as fast newsprint machines utilising 100% RCF were built for 1500 m/min.

The general tendency of tightening supply may in future partly be compensated by fractionation and other technologies helping papermakers to more optimally utilise the available RCF.

49

20.9.2010

Further increase in collection rate will unavoidably increase the share of mixed grades. Technically it is a highly interesting question, how to improve utilisation of mixed waste paper, i.e. how to make the best of its different components.

Technical development has been decisive in the development of RCP utilisation. RCP provides a cost benefit only if it can be technically effectively utilised. Improving the effectiveness of RCP utilisation has been the direction of technical development and has in turn enabled stronger demand for RCP. Also the paper machine concepts have developed to support high utilisation of RCF. However, quality of RCF is becoming poorer all the time - this creates further pressure for technical development.

These comments mainly reflect general optimism regarding continuation of technical advances in the field. This provides some support for the hypothesis of further increasing demand. [Back](#)

20.9.2010

I.ii Substitute price development (= Virgin fibre price development)

The theme of substitute price development was clearly the least touched one in the 1st round interviews. Some general comments on the applicability of substitution were made:

In long term virgin fibre and RCP are substitutes but relatively few mills have any flexibility in short term.

Price gap of RCF and virgin fibre will maintain [*not constant but at a reasonable level in long run?*]. In 2008/2009 there was serious oversupply of RCP and the prices were temporarily down to zero. Perhaps the price gap in absolute terms was still the lowest – as the price of virgin fibre was also at a low level.

The price of RCP will follow virgin fibre price with certain delay. Also the inventory speculation has a major influence. Different grades of RCP behave differently [*as also their substitutes on the virgin fibre side ar different and behave differently.*]

[Back](#)

Follwing factors influencing the virgin fibre price development were brought up:

The recent peak in pulp price [and RCP price] is explained by the fact that during last 1½ years a lot of capacity was closed and inventory levels were brought down. Now when demand has waked up that capacity is run at full rate and even idled mills are restarted. In fact, Rizhao pulp mill was the only investment that was carried on through during the recession of 2008/2009. This created an empty slot in the pipeline of virgin fibre capacity investments and now it takes a while before the new capacity announced in South America, Australia and China comes on stream. This will show in 2013-2015 as a peak in new capacity to the market.

Price of pulpwood is on a rising trend because it is renewable. The CO2-benefits will come on top of that basic fact.

CO2-trade will in future increase the price of energy. This will further improve the position of RCP, especially ONP's.

Burning of wood will increase, having an impact on prices of raw materials. [Back](#)

Development of energy price has an impact in demand of RCF through mfg cost of virgin fibre. It will direct to use RCF instead. There are signs that we have reached “the end of the road”, though. [*Meaning that the use of RCP in graphic papers has little room for growth.*]

VF supply has higher price elasticity than RCF, especially when capacity utilisation rates are high. Most pulp mills usually operate below maximum operating rates and are able to stretch their output by increased demand. Obviously in long term the flexibility is brought by new capital investments. (Though the leadtimes are long, easily 24 months) Also the inventory capacity is higher in VF.

51

20.9.2010

It is not foreseen that significant amounts of pulpwood would move to bioenergy. [*Why?*]

Some general observations were made on the industry development:

As long as the global consumption shows growth, there will be need for investments both on the virgin and recycled fibre.

In long term the investments in plantation forests in the southern hemisphere and improving economies of scale in chemical pulping will keep the pulp price either declining or only moderately increasing.

Virgin fibre based integrates will have certain cost advantage in future. (in North America and Scandinavia)

In China, small straw pulp mills have been closed during last years for environmental reasons but re-opened lately as a consequence of high pulp price. In medium term the trend to close the most polluting small straw pulp mills will continue. Their fibre output will be replaced by partly new more advanced straw pulp mills, partly by South American HW and partly by RCP. Also SW pulp continues to be needed in the mix. The handicap of straw pulp mills is the reasonable scale of operations that is limited by transportation cost of the raw material. One interesting concept could be to produce EtOH from straw.

When assessing the technical development one should bear in mind not to exclude the development of the virgin fibre side. Technical development continues also there.

The recent plans of closing Varkaus P&P-integrate in Finland has underlined the many linkages such an integrate can have in the surrounding city and society. It is almost sole provider of paper for the neighbouring printing house (sharing the warehouse!) and it provides district heat for the city. Arguments to keep existing virgin fibre based integrates running can actually emerge outside the core business of these plants. [*In comparison the recent investments in W-t-E at paper mill sites in central Europe are driven by making these paper mills self sufficient of energy, rather than creating a lot of synergistic connections with the surrounding economy.*]

[Back](#)

20.9.2010

I.iii Volume development in collection (= RCP collection rate)

I.iii.i General direction of supply development [Back](#)

Comments arised on **general direction** of development:

Meeting the demand (=increasing utilisation rate) will become more and more difficult. The shift from 70-75% in uti-rate is totally different challenge than from 40-45%.

In general, another big hindrance of investments is the high price volatility. Brown grades may fetch 200 €/t but only 0 €/t the other day!

The supply is today very rigid. The quantities are collected whatever happens on the market. The system 20 years ago, that was to a large part based on boyscout etc activities, was much more flexible. When paper mills stopped paying for the collected quantities, the collection stopped and the quantities ended up at landfills.

According to fresh statistics, the collection rate in CEPI-europe (29) has reached 72% in 2009. On the collection side there is some potential in the new member states but by absolute terms their volumes are very small and have minor significance. In US the collection rate is currently at 63% and has still some potential. There is however no legislative drive and any further increase in collection will be based on economic factors. All in all there is maximum potential of +5% in the EU/US collection rates.

Technically the maximum collection rate is app. 80% [*The rest being disposed into sewers, buried in libraries and archives and burned in domestic fireplaces.*] Considering all above mentioned, the tight supply will remain. It will drive some players out of the market. Collection has to be extended into new areas like middle east, Africa, etc.

Eventually there is probably going to be some trend back to virgin fibre.

In Germany today, there is practically no RCF in MSW flows to landfills. [Reason1: Landfilling of MSW has practically ended already; Reason2: MSW is processed into "Ersatzbrennstoff" (RDF)]. General trend in Europe is following the practise adopted in Germany.

The RCP price is the most important factor affecting the development of collection. If price stays high, the collection is extended further. Households, SME's, SOHO's are the biggest potential. '

Demand of high quality recovered paper (RCP) will increase. When prices improve, it creates a room for improving the collection as well.

In general, legislation is the factor influencing the collection most.

Growth potential in collection is very limited as the collection rates are already very high. Political decisions are again very important. Into which direction will the waste management systems develop? What is the role of RCF in those? After all, the cost efficiency of the systems

53

20.9.2010

will be decisive. Most efficient option appears to be a system where the RCP that is easy to collect and sort is recycled and other RCF content in wastes is utilised as energy in very simple ways [Co-combustion?]

Looking at the likely developments in waste management (including collection of recovered paper) one can see three alternative scenarios: 1) reduction of wastes, including the weight of packaging. It means rather thin than recyclable. 2) more durable products and packaging. I.e. increasing the life span of products. For packages it means more re-use opportunities. 3) improving the recyclability of products, including packaging (favoring paperboards). It seems that the most feasible and likely option in long run is the first mentioned. It further means that the main waste management option becomes combustion and energy recovery. Factors pointing into this direction include the growing popularity of composite materials (due to their better functions). EtOH conversion might be interesting in parallel to other energy recovery options. RCF is one of the most homogenous and high volume fractions in wastes and therefore attractive for developing such utilisation options as the EtOH conversion.

[Back](#)

On regional and national differences:

Household collection in Europe is legislation driven. North American system is more economics driven, i.e. collection takes place when there is a market for the product.

In China it is quite difficult to drive the collection rates up. Regionally, e.g. in Shanghai, already 85% collection rate has been reached. The system is based on door-to-door collection and resembles the old "boy scout system" in the west.

The low overall collection rate of 45% in China is of course a result from heavy exports of packaging, product manuals, etc. China is dependant on imported fibres. Majority of ready packaging material exits the country with the exported goods. Therefore China will have a difficulty to report a collection rate above 40%. In fact this means that there is a bias in the collection statistics in Europe / NA in the different direction. How much, it is impossible to tell. In general the statistics in RCP collection and utilisation leave a lot of room for improvement. Better statistics of collection would be needed, preferably split by different grades.

In Europe there are quite large national differences in general environmental attitude, traditions in resource use etc. that affect the development of collection rates.

Companies (in Finland) are today really motivated to sort all their wastes. This is partly due increasing interest in various environmental certificates, environmental & social reporting etc. This will help to increase further the supply of RCP as well. Recycling options clearly yield the best net impact in CO₂, especially when the balance is calculated just over the Waste Management operations.

20.9.2010

On the paper side, the value of RCP more than covers the collection costs. On the brown side the volatility is greater and time to time the value of product does not cover the collection cost in Finland. Increase in collection volume is achievable with small incentives and mandatory actions. It is also possible that the demand will strengthen and support the situation by higher prices.

The utilisation of RCP in Finland is on a downward trend. This might create room for waste-to-energy solutions as well as exports in future.

E.g. in Finland the municipal waste operators that are often organised as joint service for larger amount of municipalities are a difficult factor on the market. They have huge vested interests but little monitoring by anybody. If they invested in a mass burn capacity, it would easily mean that there would be serious set-backs for recycling. When investments are done, it is important to get flows in, even with lower prices and even at the cost of recycling targets. Such plants would not only eat up the growth potential in collection of RCP but some volumes already within recycling would be endangered as well (!!)

EU legislation of producers responsibility is one of the most important factors affecting the development of RCP market. The national implementation of the producers responsibility differs a lot, but the overall demands should be universal in EU. Of course some countries are taking more prompt actions and approach to meeting the EU requirements. At the moment in Finland the producer community has to partly finance the recycling of brown grades. (On the paper side, such need does not exist.)

[Back](#)

I.iii.ii Role of Legislation in comparison to demand development [Back](#)

Among panelists there were contradicting opinions whether supply is more drive by legislation or by price (=demand):

Collection is impacted most by legislation. It is partly supporting but partly also preventive. However, e.g. closing of landfills in Germany didn't show up in collection rates at all.

EU 2016 landfill rules will stop disposal of RCF containing flows at landfills.

Supply development re: household fractions is totally dependant on development of legislation. There is still some political pressure to increase its collection. WRAP-program of UK is a good example of a politically driven activity that ramped-up the RCP collection in UK and made it the largest exporter of RCP in Europe in relatively short time. The good progress in terms of collected volumes was partly due to activation of municipalities and their inhabitants and partly due to setting up of the commingled collection systems which favor quantities over quality. Also in Northern Italy there has been built "recycling facilities" that are able to sort misc. recyclables and have impacted Italy to become a net exporter of RCP. At the same time the big surplus of Germany was eaten up by the investments in local utilisation and Germany no more is

55

20.9.2010

an exporter of RCP. All that said, still a degree of saturation is around the corner in the European collection rates.

In collection, the main driver has been political steering like producer responsibility. There have been even some mandatory requirements to collect and recycle. Even so, the whole RCP collection is probably still economical.

The institutional factors, i.e. the recycling targets, have had their impact as well. Earlier, in the beginning of 90's the collection was subsidised but there's no need for that anymore.

[Back](#)

I.iii.iii Factors affecting the short term supply

Following observations by panelists can be linked with supply development in short term:

It seems a reasonable assumption, that the delay from reduction in paper consumption to similar reduction in collected quantities of recovered paper (=supply) is very short and can be neglected. I.e. changes in collection rate due changes in consumption are a very short term. [*Still visible during recession of 2008/2009 !!!*]

Historical price behavior has shown very high volatility. Much higher than of virgin pulp. One explanation is probably the smaller warehouse capacities at mills. Very typical capacity in Europe is only 7-14 days of consumption. In China the situation is believed to be different, with higher inventory possibilities, even 3 months. Another explanation are frequent rumours among buyers and sellers. It is a mystery why European utilising parties don't want to invest in warehouse capacity. In general, the players, especially on the collection side are not willing to disclose their warehouse capacities.

Hedging instruments are available in the market. They should have a balancing effect on the price behavior.

Most significant factor explaining the price development in the past is inventory levels. Collection cost is the underlying factor setting the base. Earlier there was an amount of subvention included. Now the system is more transparent and more commercial. Also municipalities see an earnings possibility with ONP/OMG.

There is a price connection between RCP grades due substitution effect. Containerboard mfg can easily utilise a small amount of ONP/OMG if they run short of OCC or if it pricewise makes sense. Similarly tissue mfg can utilise some amount of ONP in their dip processes. This is a handicap for graphic papers producers as the big volumes are on the brown side and the substitution technically works one-way only.

I.iii.iv Role and development of collection systems [Back](#)

56

20.9.2010

Most respondents considered that commingled collection has capacity to increase collection rates and will gradually win market share:

There has been a strong general tendency of increase in collection rates. E.g. UK has reached already 78%, partly thanks to the commingled collection system. However, from the European point-of-view the commingled represents only 3% of total RCP collected.

MRF sorting facilities are a clear trend in sourcing of RCP. All paper companies aim to get a hold of these flows. It helps to further improve the public acceptance of paper recycling if also other recyclables are somehow sensibly treated.

In RCP collection, the ideal system of 3 separate components has prove to be too expensive. The commingled system that relies on sorting plants is gaining ground. It is the preferred system in UK and partly in use in Germany as well (yellow sacks).

It seems that commingled collection will win market shares as technology in sorting is developing. Probably the end result is better from the economics perspective even if the quality of RCP is little poorer. Also the lead times in recycling will improve.

For instance in UK there are several collection practises in use. Even in same region there are overlapping collection systems. For good access to RCP one has to use all sources.

In collection, interesting question is which path the new member countries will pick. The UK commingled system and German multi-bin system are true alternatives.

The cost structure of collection should be viewed by the grades of RCP. In general, the sorting costs in Finland are low. German system with a joint collection bin in households yields much higher sorting cost. At least 20-30 €/t.

Different types of supermarkets have different cost structure for RCP supply. A large hypermarket with own bale presses is totally different to local small supermarket at the countryside.

Collection has different logic in urban vs rural setting. [*i.e. the cost structure and thereby optimal collection system differs.*]

In Finland, the collection of packaging grades from households is still in its infancy. There is a strong potential for volume growth, even if the sources in commerce and industry are already well covered. This trends comes partly from legislation.

If household and rural collection of packaging was profitable in Finland it would be done already. As a separate fraction it is very expensive to collect in a large sparsely populated country like Finland. One has to bear in mind the bulky nature of packaging materials. The bins fill up quickly with small weight. Perhaps a combined collection of all packaging materials (plastics included) would help drive volumes up. This makes the EtOH-concept very interesting.

[Back](#)

I.iii.v Potential conflict of interests [Back](#)

It came up frequently that Waste Management companies and paper companies utilising the recycled fibre might in future end up in more and more direct competition for control of waste flows:

It is foreseeable that the conflicts in interest regarding collection and use of RCP (and recyclables in general) will increase. E.g. paper companies and WM companies clearly have a different agenda. Paper companies want to ensure availability of their raw material in long run, whereas the WM company may burn or recycle based on short term business interests.

There is a big competition between waste management companies and paper industry. WM companies have originally been service companies, charging for the service of collecting and transporting the waste for disposal. In future, also these companies will strive to create more and more revenue from recycling and products. Also municipalities are eager to get their share of recyclables sorted out of waste and sold.

Interesting strategic question is how the RCP users, i.e. paper companies, are able to enter the collection business. Today different paper companies have highly different positions but it appears that all are aiming at strengthening their positions to reduce their vulnerability to price volatility of RCP. Biggest volumes are still collected by the WM companies.

Paper companies have recently announced investments in Materials Recovery Facilities (MRF). These aim at backward integration. In the current market conditions, the entry in collection and sorting business seems one of the available options to ensure the supply of RCP and to improve its cost structure.

It is still not self evident that paper companies should invest heavily and enter [*the highly competitive and political*] waste management business. Quite often P&P companies still think that being involved in waste business is not good for their image.

There is a huge variety of business models and tendering practices for municipal flows. There are integrated WM contracts as well as dedicated contracts for certain flows. The contract may include collection, sorting and marketing of the recyclables. In some cases the municipality wants to take part in the sales revenues themselves and just pay for the operations plus a small premium. In general, the municipalities are on the driver's seat.

The strong position of WM companies is partly for historical reasons. Also municipalities of certain metropolitan areas are in strong position and have collection and sorting capacity of their own. (Munich, Paris)

Waste business is characterised by long contracts. Change in ownership of municipal flows happens slowly. OCC is more captive market than ONP/OMG.

20.9.2010

[Back](#)

I.iii.vi Role of technical development

Likewise in utilisation, there is technical development taking place on the supply side, in collection and sorting:

There are new technologies available and under development in sorting of different materials. NIR, X-ray and combinations thereof are being researched e.g. in TH Aachen. It will improve ability to sort very mixed streams which in turn will improve the coverage of collection.

There is currently discussion whether one should simplify the current German collection system and combine e.g. the yellow sack with the gray or the blue bin. The idea is to further improve the recovery of materials. Cost effectiveness is being debated. Also, if municipalities will find it in their interests is unclear. If the mentioned new collection systems and especially the new sorting technologies would be introduced, they would increase flexibility in the market.

20.9.2010

I.iv Market development related to utilisation of RCF as energy

With the perspective of currently low utilisation of RCF as energy, it is an interesting question how the ongoing technical and commercial developments might change this situation. In other words, how the paying capacity in the energy sector for various RCF containing flows might develop in future.

I.iv.i Current situation [Back](#)

In the past the solid fuel boilers of paper mills were designed to use RCF rejects as a side fuel but not really designed for utilisation of general wastes. Recently solid recovered fuel boilers capable to handle rejects but also other waste flows, including municipal waste have started to gain popularity:

At the moment boiler constructions typically in use at central european industrial and utility power plants are not suitable for burning paper containing wastes in large quantities.

Recent investments in waste-to-energy by paper mills is regarded very sensible. Besides providing cheap energy in a synergistic way (24/7 utilisation of low grade steam), it will give tools for further optimisation. Could there be more flexibility in future raw material mix?

The driving force in the latest investments (e.g. StoraEnso Langerbrügge and Maxau) has been solely financial, i.e. cheap energy. The high market price of electricity is driving paper mills to build self-sufficiency. In this capacity, the bioenergy and waste-to-energy have been the most economical alternatives. Political decisions are naturally behind this situation.

Paper mill's investments in W-t-E: it creates additional substitution in the RCP market. Probably more a threat from papermaker's point-of-view. Might help in getting the right fractions/flows in right uses. It might help to access the marginal % of raw material or cheap energy and thereby create advantage over competition.

In Finland, there are about 10 industrial FB boilers actively practising co-firing of RDF and other (bio)fuels. Largest ones are SE Anjalankoski (130 kt/a), UPM Pietarsaari / Ahlholmens Kraft (>100 kt/a), UPM Rauma (>60 kt/a). Lahti Kymijärvi is the only municipal CHP power plant using significant amount of RDF (40 kt/a, in future 250 kt/a!). In fact, there would be no need for municipal mass incineration plants in Finland.

In Europe, growth of co-firing is significant (e.g. recent big investments at paper mill sites in Germany). There are different interpretations if co-firing of RDF, residues etc. is calculated under CO₂-trade or not. (For powerplant operators, the earned CO₂-credits are important part of the revenue.)

The cement kiln who used burn majority of RDF in Europe are not as competitive as industrial CHP FB's because they demand very low incoming moisture and small particle size of the RDF. Industrial FB's can handle high moisture and particle size and can therefore accept waste with smaller gate fees or with no gate fees at all.

20.9.2010

In Europe, first signs of mass incineration running out of waste are already in sight. Rotterdam 380 kt/a facility was recently run down long before the end of this technical life-time due lack of fuel. Also in Sweden, where mass burning is effectively utilised in district heating networks, the plant are suffering from the lack of waste. They have actually started to import waste. The fight for wastes has already started in serious.

Germany, at the moment, has too high capacity of MSW incineration which may hinder the market development. The municipalities underestimated the market impact of emerging use of SRF in industrial power plants. There were misleading studies published still in 2007 and 2008 asking for increased MSW incineration capacities not seeing the growing interest for alternative fuels and thus increased SRF demand. Now there are lot of suitable boilers already in operation and under construction in P&P and chemicals industries running in the CHP-mode and therefore working with a high annual efficiency. As a result there is overcapacity of MSW incineration in the market. Therefore Urban Mill and other industrial CHP based concepts for SRF utilisation have to compete with MSW incinerators.

[Back](#)

I.iv.ii Combustion in solid fuel boilers [Back](#)

Following comments were received on the threat of direct combustion of RCF containing flows:

Recent analysis clearly shows that RCP is too expensive to burn. Coal, even when loaded with 30 €/t CO₂-credit and wood are less expensive fuels than even the cheapest RCP at today's price level (OCC=24 €/MWh). The only exception might be certain commingled streams. However, the municipalities and politicians are strictly against burning RCP containing flows and won't allow it. Interestingly, also all wood, excluding sawn timber, is today cheaper than RCP when measured in €/MWh.

Solid fuel boilers utilising residues and external fuels are today part of the money-making concept at paper mills.

In Finland there is a lot of co-combustion of waste already taking place and it will continue to grow.

Co-combustion, i.e. utilising recovered fuels in paper mill solid fuel boilers that are designed for residues, biomass etc., continues to gain popularity. Especially in those cases where there are existing strong linkages between the paper mill and the surrounding municipality (in form of district heat etc.).

If price of poor quality RCP grades remained low in the long run, large quantities of it would move to combustion, mainly in industrial fluid bed boilers. Current price level of energy wood, 18 MWh/t corresponds 72 €/t of RCP which is above the price of lowest grades at the moment [*In Finland*]. On top of that comes the benefits of simplified logistics. Today all new industrial

20.9.2010

boilers are permitted to include waste because in practise there is no difference in the allowed emissions.

[Back](#)

20.9.2010

I.iv.iii General direction of future development [Back](#)

Panelists comments on general direction of energy utilisation of RCF containing flows:

It is possible, that alternative use as a fuel will emerge, though. That would change the situation and possible CO₂-benefits in the range of 5 €/MWh already have a role. The fuel market might become a “second China”.

Waste hierarchy has been established. A question is if the burning of usable materials can be sanctioned. The fact the RCP is classified as waste can actually protect its use as raw material as its transportation and combustion requires special permits.

In future, the energy use may become more important. The paying capability for wood, including subsidies, will decide where the wood will be utilised. Paper industry at the moment can't afford to pay as much as energy sector. This is today main issue in Germany and there is a risk that same repeats in RCP. Currently, however, it is legally recommended to use RCP primarily for value creation and then for energy. There are no subsidies included at the moment. *[This recommendation might have only limited impact in reality. E.g. as all RCP sorting plants produce an amount of residue which is contaminated and expensive to sort into commercial RCP grades, the operators may find it easier to increase the sales of this residue as RDF than to invest in perfecting the sorting result. Also it may become more attractive for WM operators to extend RDF sourcing in comparison to extending the collection systems producing flows for RCP sorting. So even if the legislative recommendation to use RCP primarily as raw material would be able to keep >90% of current flows in raw materials use, it is probably incapable to ensure future increase of supply.]*

When aiming to increase use of biomass based energy, waste – including its RCF content – is a rational alternative. Today, however, RCF is mainly used for cost reasons in papermaking and it seems unlikely that any significant market would emerge for combusting RCP as such. It would require subsidies that were too expensive for the society – on top of impacts of the loss of effective paper production capacity. On the other hand, co-combustion of flows that contain also some waste paper continues to gain popularity. This is eating up part of the growth potential in RCP supply.

Besides development of demand in mfg. of paper products, the demand of RCF will be impacted by its future use as fuel and as biocomposites. These are minor flows compared to RCP, of course.

As an investor in waste-to-energy the paper industry has dual interests. One is to secure its raw material supply. Second is to acquire inexpensive energy for its needs. There might emerge some new possibilities for optimisation between the raw material and the fuel streams. There are better possibilities of synergies if a single paper mill is able to trade with mills producing different grades.

20.9.2010

Important question will be how the fuel use will be subsidised. Part of the useful RCF potential will go to fuel use. The price [*or paying capacity of different utilisations*] will decide, but it will include the impact of taxes, subsidies and like.

It seems that 50 additional waste incineration plants will be built in Europe in near future. Interesting question is what benefits are available at MSW mass burning plants if RCF separation systematically took place in front of them? Is it anyways worth the small additional investment? Practically all RCF lost from the circulation would become attainable. In general, the investors in W-t-E are not interested in the fibre.

In general, boiler investments that are part of the waste management solution are purchased as waste management solutions not as energy driven solutions. The decision makers are administrative people, not engineers. The package, how waste is utilised and at what cost is the decisive argument.

So far, large scale use of RCP in either EtOH conversion or direct combustion has not realised. Especially in EtOH –conversion is a sound way of utilising RCF also from the moral / ethical aspect.

The prognosis is that average gate fee for all commercial and industrial waste reaches zero latest in 10 years. The same happens eventually for household fractions as well but slower, in 15-20 years. WM companies will make all their money from sales of recovered materials and fuels. Today refuse derived fuel sells in Finland for 5 €/MWh. This translates to 25 €/t.

Comment on the price development of SRF: the value slowly turns positive. Factors increasing the price today are high calorific values and high biogenic contents. Usually these don't coincide within the same flow. [*Biogenic share in the combusted waste gives CO2-credits. Dry waste paper is an exception having both high biogenic content and a rather high calorific value.*]

Oil price and CO2-credit price will have an impact on the RCF market as well. Other investments in energy sector like large nuclear power plants will also have an effect.

Oil price is gradually increasing to 100+\$/barrel level. Already 80\$ is remarkably high price during global recession. As a mega-trend this will improve the competitiveness of fibre-based packaging over plastics, glass and metals which are all more energy intensive to produce.

[Back](#)

I.iv.iv Impact of politics in the market development [Back](#)

Practically all respondents found political decisions highly important in market development:

Political decisions have big impact on the market. Decisions may not always be economically rational and are sometimes unpredictable.

20.9.2010

EU legislation has a huge impact in the development. Strict implementation of landfill directive, as has been done in Germany, calls for a number of investments and thereafter fixes the market for 10-30 years.

The biomass question as such is a major potential influencing factor. The drive for increase in the use of renewable energy and biomass fuels is deeply linked with wood availability and RCP availability. E.g. in Germany 110 M m³ of wood is annually utilised. Only 9 M m³ is utilised for paper. Some 35 M m³ is utilised as fuel and represents roughly the natural fraction of fellings most suitable for fuel use. Some 65 M m³ is used mainly in construction and otherwise as material, e.g. in furniture. Any increase in fuel use will tighten the wood supply for other uses. This means competition between value creation and fuel use and from economical point-of-view there is a risk of destroying value. So the future development is greatly dependant on political decisions.

There is currently a lot of renewable energy hype and biomass represents the biggest realistic potential. The outcome of the development is difficult to predict. E.g. in Berlin there is a biomass power plant project under planning that alone would utilise 1 Mm³ of wood /a. Whether this project will realise or not remains to be seen.

Part of the political game are also the recycling targets. These are political as well. 20 years ago when the DSD system was set up as the producer responsibility system for all packaging users, the paper industry did not want to extend the system into paper recycling in general. This was a huge mistake as it would have enabled the paper industry to have a control over the RCP flows as is today the situation in Finland where paper industry took that role through Paperinkeräys Oy. As a result it is the WM industry and municipalities who have the control over majority of RCP collection in Germany.

The various subsidy schemes are confusing the market. They are always in picture for energy and will remain as it is a clear political direction.

The public concern on global warming and thereby emerging CO₂ cap&trade systems are now changing everything. It is an easy to explain political theme. As a result the concrete 2020 targets in EU are almost completely biomass based. But all this is quite natural as energy consumption is globally one of the most challenging issues, as is the waste management and they wont disappear. [*i.e. from strategic point-of-view paper industry must learn to cope with them - and even play an active role in some cases!*]

EU target of 20% renewable energy is a clear threat for paper industry, including RCP users. Price of energy will increase, maybe paper industry's purchasing power and capacity will weaken. It will have a lot of impact. There seem to be much more threats on the market as positive signs. As the market is already quite tight and the demand continues to grow faster than supply, the additional threats have big impact and the volatility of market will only increase. There are actually first signs that investments are made also in TMP (Holmen) because of uncertainties in RCP supply.

65

20.9.2010

Political targets and legislation in bioenergy will impact the market and will create competition for the raw material. It remains to be seen how decisive these are. Anyhow, it is clear that the player who has the raw material flows in control is in best position as it can decide which flows to sort and utilise and which flows to sell out. Tendency is towards self-sufficiency in raw material supply.

In Finland the NGO's are persistently opposing waste incineration as it supposedly makes the waste disposal too easy thereby not encouraging to reduce waste production. However, there is at the moment so much pressure to increase fuel use of biomass that it will probably have some impact on the RCP market as well. I.e. different fibre and energy products [*markets*] will exist in parallel and the prices will be determined with some mechanism [*supply and demand*]. Taxes and landfill fees will also step into the picture having an impact. In some cases the transportation costs may become limiting factor, though probably not in Central Europe where collection radius are typically small.

In the past in Germany the low price of landfilling and failure to establish a landfill tax slowed down the development of big projects. Finally, the landfill ban of 2005 has resulted in a large number of projects [*as witnessed by the list of SRF boilers in P&P*].

[Back](#)

Also CO2 cap&trade system is considered to have an impact on the market development:

CO2 cap&trade-system: the whole system is a kind of iterative tool all consequences of which are difficult to foresee. E.g. it's impact on the RCP market. Perhaps, at the end of the day, the EU waste hierarchy is more important and will insist that RCP is primarily used for producing new paper products.

Carbon footprint has become the driving factor when comparing alternative solutions.

A decisive factor in technical development is the cost of CO₂-reduction per each technology. The technology that proves lowest cost of CO₂-reduction emerges as the winner. Today biodiesel-production in Germany is still much too expensive compared to actual CO₂-certificate costs of ca. 15 €/t CO₂. Photovoltaics is on a decreasing level of > 1.000€/t CO₂ reduced.

It is also difficult to foresee the impact of CO2 cap & trade systems to the market. If a truly global system was in place, probably already a price level of 5-10\$/t of CO2 would be high enough incentive to cap the emissions in places where globally the most effective returns are available (i.e. most avoided CO2-emissions in relation to investment). Now, in Europe we may well see price levels exceeding 30€/t. There is direct analogy to Baltic Sea protection. The effluent treatment investments should be placed where biggest reduction potential is available for a given investment.

Even if global cap&trade system would not realise, EU might still want to pursue its own system because it is expected to create indirect benefits in form of technical development and export

66

20.9.2010

opportunities for technology. Wind power is a good example of such sector. Yet another open issue related to CO₂ is what political decisions are made on forests' / growing stock's role as sinks.

CO₂-trade is a strong driver. If CO₂ credit reaches 30€/t level, all RCP would be profitable to burn. Today CO₂ trades for ~10 €/t. Increase of 20€/t would mean price increase 10 €/MWh for all fossil fuels like peat. This would boost the fuel price of RCP by some 40-50 €/t (on top of its current 72 €/t level).

Impact of the CO₂ trade is mainly through price of energy. It will increase the cost of virgin fibre and thereby induce further the demand for RCP. Only if it would lead to increasing combustion of pulpwood it impacted the market more radically. One common misunderstanding is that the tropical plantation wood based pulping capacity would be easy to expand endlessly. Actually the limiting factor is the availability of suitable land area for the plantations. It is difficult to acquire in the needed quantities and in suitable locations with enough water. If plantation wood was converted to bioenergy, that would be simpler to grow and harvest and it would mean a big change. The general predictability of the CO₂ cap&trade system and its impacts is by nature very poor (due to the political connection).

CO₂-trade has an impact in Europe. Largely the system is working against us as long as the other nations don't follow. It is unfortunate that you don't earn CO₂ credits by producing RCP-based paper.

[Back](#)

Several comments were made on mandatory bio-content in transportation fuels:

When assessing the political targets for bioenergy one should bear in mind that today 2% of transportation fuels globally are so called alternative fuels. Increase by 1%-unit is a tremendous amount and challenge. Globally, share of biomass in all fuels is 12%. Annual yield of biomass by photosynthesis (excluding seas) is about 100% of our annual energy need.

Using wastes to produce transportation fuels is politically attractive as many of the present biofuels are competing with production of foodstuff or have some other ethical constraints such as the palm oil (jeopardising the jungles). Their use in fuel production is expected to diminish.

Another big impacting factor in future development are the material recycling obligations stemming from the EU legislation. It is an interesting question how EtOH conversion will be classified in this respect. In EU packaging waste directive controlled organic / biologic utilisation is classified as materials recovery. Fermentation of waste fibre based sugars can be considered as controlled biological utilisation. Same applies to the biogas generated as a by-product in the EtOH conversion. This interpretation would actually open up many contradicting demands in legislation. E.g. to increase the bio-component in transportation fuels and at the same time increase the materials recovery from wastes. At the moment, landscaping of old landfills by

20.9.2010

poor compost is treated as materials recovery! Where as the very sophisticated process to produce gasoline substitute may not.

Also on the biofuel side, it is dominantly the mandatoy requirement that comes from the EU legislation that is pushing the development. The biggest obstacle of eventual investment decisions will be how to secure the availability of raw material for the plants. The market of the end products is safeguarded thanks to the legislation.

It is clear that one of the effects of current economic crisis in the development of renewable energies has be a restructure of the national funding systems (i.e. the German EEG) to more cost efficient technologies. Can we afford extreme subsidies in future?

[Back](#)

20.9.2010

I.iv.v Technical development [Back](#)

Majority of panelists had only limited expertise to judge the pending technical developments in Waste-to-Energy, including waste based EtOH –concept. Following key observations were made:

Fischer-Tropsch is a proven technology. South Africans have manufactured transportation fuel of coal for decades by it.

The development project at StoraEnso Varkaus mills [Fischer-Tropsch conversion of forest residues to wax that is used as raw material for biodiesel] is based on the vision of integration benefits (365 days/year sink for surplus heat) and raw material sourcing benefits (forest residues). It is of huge importance to Finnish P&P-sector to develop further our integrates. It will improve our competitiveness and create know-how that is converted into exports by machinery suppliers as well. It is very likely that we will see major investments (200 M€/pce) in future.

There is a kind of illusion on the market that EtOH and biodiesel will be gold mines for the industry because the politicians say that there has to be biocontent in transportation fuels. But what if the political targets are not met? What are the sanctions? Probably nothing else but some vague complaints. It will be very unpredictable to make heavy investments that are based on the assumed subsidies for biofuels.

Some investments in 2nd generation biofuels will take place but there is a lot of hype in the discussions. There is in fact direct analogy to pulp mills: these are huge investments, the raw material volumes are really big, the price behavior is cyclical and there is about 50/50 yield/energy conversion –ratio. All in all it means that there is a desperate need to build integrates as production of condensing power is usually not very attractive.

Biodiesel investments (based on forest residues) will be the second stage. EtOH and pyrolysis oil both require much less investment and can thus act as piloting investments in this bigger entry to a new business area.

In the case of the so called 2nd generation waste-to-energy concepts, like the EtOH conversion of waste, the situation is much more unclear. Probably these investments will not realise without significant subsidies. These subsidies must include subsidies for the investment, tax benefits / feed tariff –type of benefits as well as a guarantee for feed stock availability. Are we as a society ready to pay the high price that is required for e.g. 20% renewable content in transportation fuels?

It is clear that waste-to-energy concepts will be implemented at paper industry sites. Handling municipal waste is a mean to get a hold of the RCP/RCF flows. The paper mill site is actually the most valuable asset paper industry has. It includes many useful infra to make money, including water treatment and waste treatment. This is especially true in Central Europe.

20.9.2010

Biocomposites and biochemicals and bioplastics are part of the biorefinery concept, not only the liquid fuels. Also different composite structures of recycled plastics and wood products may emerge.

It would be more logical to source feedstocks for biodiesel production on the southern hemisphere where the growth is much quicker.

Likely applications for gasifier technology are to be found in industrial uses. Maybe not in pulp mill lime kilns, unless the oil price is high enough, but perhaps in chemical industry or at fossil power plants. Use of gasifying technology for transportation fuels is difficult because of the purity requirements. Advantage of gasifying is that the syn-gas is ash-free.

Modern grate technology can case-by-case be as energy efficient as FB combustion of SRF/RDF when pre-treatment cost and energy consumption are included in calculation. Utilisation of CHP, i.e. the process steam is the decisive factor in economy and energy efficiency of the plants. The FB boilers capability to handle moist sludges is usually the decisive factor in industrial applications.

The ethanol concept is likely to proceed within next five years in Finland. It might be realised as a series of smaller units put up in optimal places regarding raw material sourcing. (In Europe, because of the dense population, bigger units are more likely)

It would be very positive if ethanol or biodiesel would be produced at a paper mill. This would offer a serious alternative for municipal mass burn investments. It is not known though, if the manufacture of liquid fuels would count in the recycling targets. There are arguments for and against that.

Waste fibre based EtOH-concept will breakthrough in coming years. It is the cheapest raw material available for ethanol. Enzymatic hydrolysis is working well, it remains open however, what is the cost level of enzymes in the long run when volumes are high. Also the dilute-acid route is possible. It is a little heavier investment-wise but more flexible re: the used raw materials. EtOH-concept will decrease the exports of surplus RCF from Europe – or at least increase the price level significantly.

From strategic point of view, it is an interesting question what type of flexibility EtOH or other biorefinery component would give for a major RCP consumer. (E.g. if one controls RCF-containing flows exceeding the demand in paper production by 1.5x, there surely is certain flexibility how to react in situations of changing RCF supply. Assuming that one can adjust the EtOH production capacity to changes in supply and keep paper production constant - or the other way around?)

It appears that RCP based paper industry is an excellent position among all industrial CHP-owners in utilisation of SRF because it produces 15-25% of the fuel need by itself in the form of different rejects or sludges of RCP processing. Nevertheless there are ongoing investments also

70

20.9.2010

in chemical industry, e.g. by E.On near Frankfurt.

[Back](#)

Technical and cost level -related discussions on the **ethanol from RCF –concept**: [Back](#)

A recent signal from the market is that four out of the six large DoE funded development programs for EtOH production have ceased. The likely reason is the lack for economy, especially for ligno-cellulose based concepts. None of the grain-based concepts fulfills the needed CO₂-impact criteria (Most have increasing or only marginally decreasing impact in the CO₂ emissions).

EU has recently accepted 4 large demonstration projects for EtOH production. One of them is the finnish lead waste based EtOH. Others are straw EtOH (DEK), corn EtOH (Avenboa, SP) and sweet sorghum EtOH (IT).

Cost benchmark for the european development projects is Brasilian sugar cane EtOH with production cost of 30 €/l. Considering transportation and customs it translates into 50 €/l. Waste EtOH is calculated to reach the benchmark production cost of approximately 50 €/l. All other concepts being demonstrated in EU fall far behind, at the level of 90-100 €/l.

Typical production cost level for ligno-cellulosic EtOH is 2€/l. If RCP was converted into EtOH that sold for 2€/l ("feed tariff"), the plant could pay ~200€/t for RCP. For the EtOH sales price of 1€/l, the paying capability is about 40€/t of RCP. Direct combustion of RCP at fuel cost of 18 €/MWh would yield a price of about 70-90 €/t of RCP.

In general, it appears that RCF (either as RCP, or even more so as part of MSW flows) is the cheapest source of sugars available at the moment. If MSW/CIW based EtOH proves too difficult, after all, pure RCP for sure is simple feed stock for EtOH processes.

Theoretically a competing path to produce biocomponent of transportation fuels can be found from tailings or by-products of kraft pulping. Most recent and advanced idea is a pre-processing stage with hot water to extract all hemicellulose of the wood chips into EtOH conversion. (Lignins would be recovered for energy and cellulose to pulp, as today.) From 1 Mt kraft pulp mill one can calculate app. 15-20 kt/a of EtOH. (Same amount is accessible from about 250 kt/a of MSW/CIW.) So even a mega-size pulp mill can't competitively produce very much of EtOH. Still the production process from MSW is far more simple and cheaper to invest.

Specific concern related to the bio-EtOH (or waste based EtOH) is if there is after all enough RCF in the targeted waste flows left. All these concepts are technically possible to be realised if enough political will and money is made available.

The proposed EtOH conversion of RCF containing wastes and even of pure recovered paper might emerge as an interesting alternative of RCF utilisation. (Especially if in the circumstances of declining market the virgin fibre producers tried to keep their operating rates up.) However, the production cost of EtOH from RCF has to be competitive with other EtOH raw material

71

sources. Not only with present tropical sugar cane and grain ethanol but also with future GMO modified sugar cane and straw from different annual plants. Sugar cane is a polyploidic plant which thus can't be bred. But for GMO, the sugar cane is a good platform. By GMO one can aim either at 1) increasing the yield or 2) improving the processability of the plant in the conversion (or both). E.g. GMO researchers are currently developing a straw plant that is enzymatically disintegrating itself when cut down (the cellulose molecules are actually hydrolysing?)

The GMO technology is already quite advanced. By so called "zincfinger nucleosis" the researchers are able to transfer longer chunks of DNA chain from one position to another (instead of single bases). Also the (on-line?) monitoring technologies have developed fast. Earlier researchers had to use antibiotics to diagnose what happens in the genome. (Which is a long and complicated procedure??) It is thus a relatively safe assumption that production cost of tropical EtOH from sugar cane can be cut by one third by GMO route. (It means coming down from present 30 €/l to 20 €/l. Thus bringing the free delivered cost to e.g. Rotterdam from 50 €/l to 40 €/l level by 2020.)

There is also active research around algae for producing biomass and biooil. Certain species are known to yield 30x the crop of palm oil (or was it soy?) per hectare. GMO route of algae is, however, considered dangerous as spreading of the GMO modified species is difficult (impossible) to keep in control. With the perspective that algae are responsible for the majority of Earth's oxygen generation, any experimentation becomes highly questionable. Still, thinking beyond 2020, the production cost benchmark of biofuels might well become algae, perhaps at a level of 30 €/l. CO₂-capture might also be combined with production processes of algae biomass.

Another open issue is how long the liquid fuels will remain in dominant position? Electric cars will come sooner or later. It is likely though, that huge volumes of liquid fuels will continue to be consumed on the market thus creating a sustained opportunity for liquid biofuels as well. Degree of political subvention remains unclear and there are strong arguments for and against it. E.g. reducing the dependency on oil.

There were a bit similar waste based gasification and pyrolysis projects in Germany. However, none of these gasification and pyrolysis projects is anymore in operation. There was industrial piloting of FT (CH₃OH-production) in Schwarze Pumpe but it was found too small to be competitive. Also gasification of mixed materials has been stopped in another demo plant (Contherm) that operated two rotary kilns with 120 ktpa input to feed a coal fired boiler with the syngas. The reasons were 1) complicated process, 2) availability of skilled staff, 3) efficiency and technical problems such as slagging, 4) it became more and more critical to get the needed feedstocks.

[Back](#)

Appendix IV

Delphi study on supply-demand behaviour
of recycled fibre; results of the 2nd round
questionnaire

Delphi study on supply – demand behavior of recycled fibre

DETAILED RESULTS TO 2nd ROUND QUESTIONNAIRE

This Appendix includes a compilation of all responses that were received to the 2nd round questionnaire. The results are presented, however, in a form that does not reveal identity of panelists behind individual responses or comments. [All further clarifications, explanations and comments made by author are written in parenthesis.]

1 Demand development of RCF at paper mills

Summary statements (1.1-1.4):

- S1.1 Growth in utilisation of RCP will continue
- S1.2 Technical development in RCP and RCF processing will continue to create room for increase in demand
- S1.3 The market development in the export markets, mainly China but including also India and other Asian economies suffering from fibre deficit will be the decisive component in demand development. European development plays clearly smaller role
- S1.4 In short-term the operating rate of paper mills is the most important factor setting the demand of RCP whereas its price has only small impact. Current perception is that the price of RCP will remain high for quite some time due tight supply of RCP

Do you in general agree with the summary presented above?

	Y	Y/N	N	Blank	other
n=	9	1	0	0	0

Detailed comments:

Some substitution will happen between RP Grades. General approach-> In the whole system, globally, there must be a certain share of virgin for the system to run. However, it does not go necessarily inside the simple chain e.g. TMP-> newsprint-> ONP-> onp collection-> Newsprint but virgin injection comes through magazines. Same with Liner & Fluting and OCC, virgin will be inputted in the form of cartonboards etc.

Price impact of local authority tendering processes is also quite significant. [Local authorities, meaning cities and other municipal coalitions, who have the responsibility to organise waste management in the area and who own the discarded paper within the area, seem to have an increasing interest to create revenue from that part of the waste streams that potentially has value, meaning mainly discarded paper. This implies that in the delivery cost structure of RCP, the collection fee more and more often turns into a stumpage cost. I.e. the RCP collector / dealer must pay to the municipal authorities for the collected quantities of discarded paper.]

Availability of RCP is limiting the growth today. A scenario where TMP's mkt share picks-up again is therefore possible - mainly in Nordic.

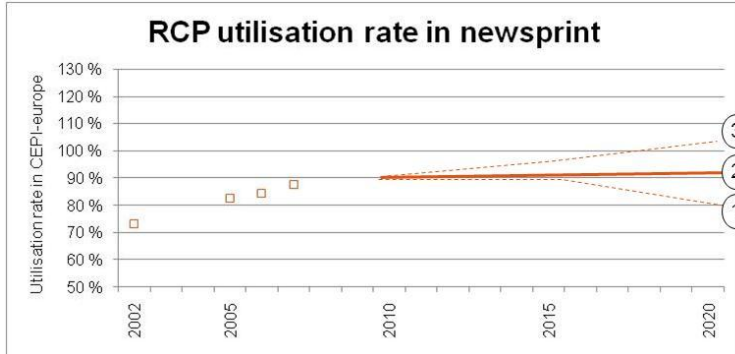

Trend 1. Historical and anticipated development of utilisation-rate of RCP in mfg. of newsprint by the panelists.

Please indicate which of the trends (1/2/3) is closest to your view of future development:

	<u>1</u>	<u>2</u>	<u>3</u>	<u>other</u>
n=	1	6	2	0

Detailed comments:

Somewhere around 90-95%. If share of OMG grows vis-à-vis ONP, the higher average filler/pigment level supports even higher "utilization" rates. [When yield of RCP decreases the utilisation rate increases, even if market share of RCP vs virgin stayed constant.]

Some RCP-based capacity will be closed down in Central Europe. [Thus indicating start of decline in RCP utilisation rate for newsprint. So far this is a prediction only, there is no evidence to-date that mill closures would affect more RCP-based capacity – quite in the contrary.]

Key arguments in favor of continued growth of uti-rate in newsprint:

- A1 Cost advantage over virgin fibre (TMP) remains. TMP cost are [will be] under pressure due to increasing cost of electricity and pulpwood. There will be scarcity of pulpwood in Central Europe.

	<u>Y</u>	<u>Y/N</u>	<u>N</u>	<u>Blank</u>	<u>other</u>
n=	7	2	0	0	0

[Yes, but] I'm not sure about scarcity of pulpwood but risk of bioenergy-driven scarcity should not be forgotten.

[Yes, because of] Energy wood. [Increasing use of energy wood will increase the pulp wood price and therefore keep up the cost advantage of RCP over TMP – even considering the increasing

price trend of RCP.]

[Yes,] *Increased biomass demand (heating etc.) among others will keep pulpwood prices under pressure.*

Today yes, tomorrow no. Price of RCP will soon be so expensive that those who can switch to virgin fibre will do.

Y (Central Europe), N (Nordic). E.g. Holmen is, though, investing in MRF's aiming at creating RCP imports to Sweden.

- A2 Despite growth in RCP utilisation rate, virgin fibre keeps entering the loop in form of OMG, i.e. magazines that still have majority of virgin fibre.

	<u>Y</u>	<u>Y/N</u>	<u>N</u>	<u>Blank</u>	<u>other</u>
n=	9	0	0	0	0

- A3 Recent evidence are the investment decisions of Palm King's Lynn in UK and Perlen Papier in Switzerland.

	<u>Y</u>	<u>Y/N</u>	<u>N</u>	<u>Blank</u>	<u>other</u>
n=	9	0	0	0	0

[Yes, but] *They phase out inefficient newsprint capacity and will earn money because they will have the most efficient mills in Europe.*

True when logistics are correct. [I.e. the mills are centrally located with respect to both markets and RCP sources.]

- A4 RCP yields will decrease which will have an impact on utilisation rates. (As more RCP is required to produce same amount of product!)

	<u>Y</u>	<u>Y/N</u>	<u>N</u>	<u>Blank</u>	<u>other</u>
n=	9	0	0	0	0

But very little due to technology improvements.

[Yes, because] *filler content increases if share of OMG increases.*

- A5 Collection rates are still improving thus creating room for growth in uti-rates (i.e. the market is mainly supply driven). [Based on earlier research, this has not been the case in the past, see e.g. Nestor 1992 or Edgren & Moreland 1989. However, this might well have changed now.]

	<u>Y</u>	<u>Y/N</u>	<u>N</u>	<u>Blank</u>	<u>other</u>
n=	6	2	1	0	0

[Yes, because of] *Positive public attitude to collection and use of recycling.*

[Yes, but] *ONP/OMG collection can be improved only marginally.*

Yes, but I do not quite [agree] .[This is a] supply driven statement. I have stressed several times

that there is no generally accepted methodology to calculate collection rate for individual RP grades. [Thus we can't measure what collection rate really is for ONP or OMG and if it is still increasing.]

[Yes,] *However, paper supply to recycling loop is decreasing more than improving collection rate can provide material to recycling loop.* [During major swings in paper consumption the following happens: in down-swing the paper consumption dips creating momentary surplus in RCP supply and when the up-swing starts there is momentary shortage of RCP before the picked-up paper consumption start to show in the supply.]

Collectin rate is improving YES, [but] I believe in global long term shortage of RCP meaning all increase in utilization rates will be difficult.

[No,] *We will run out of money needed in order to implement sophisticated collection systems.* [...needed to increase the collection rates. However, a logical questions arises: why wouldn't the cost of collection be able to be passed on to the RCP prices? This is completely normal, i.e. if marginal costs increase, the price increases and Q decreases.]

Key arguments in favor of saturation or decline of uti-rate in newsprint:

- A6 RCP prices are on clearly increasing trend as a result of tightening supply. Main reason behind tightening supply include continued growth of utilisation on both local and export markets.

	<u>Y</u>	<u>Y/N</u>	<u>N</u>	<u>Blank</u>	<u>other</u>
n=	9	0	0	0	0

Energy demand. [Also use of waste as fuel is indirectly curtailing the growth of supply.]

Growth in export market. [...is the main reason for tightening supply.]

- A7 Growth potential in RCP collection is small and will be the limiting factor in the growth of utilisation.

	<u>Y</u>	<u>Y/N</u>	<u>N</u>	<u>Blank</u>	<u>other</u>
n=	8	0	0	1	0

[Yes,] *Collection [is already] close to 100 %.* [... of the attainable ONP]

Generally yes, In some countries yes, yes.

YES related to the developed world. Increase in utilization at current industry is less relevant, new capacities requires the additional volumes.

[Yes, because] *Europe will run out of money.* [...necessary to further perfect the collection.]

- A8 Quality of furnish will gradually decrease and set up a limitation on uti-rate increase in newsprint. As a consequence virgin fibre news will re-appear as a premium product.

	<u>Y</u>	<u>Y/N</u>	<u>N</u>	<u>Blank</u>	<u>other</u>
n=	2	1	6	0	0

Possibly, but only as a small niche product.

[Yes,] *provided that RP price increases permanently to 150-200 Eur/ton*

[No, there is] *Quality, availability and pricing problem. Who can afford to produce virgin based?*

[No,] *technology can solve part of the quality problem. Customers start using SC-B/SC-A rather than paying more for virgin fiber based newsprint.*

[No,] *RCP will always be the raw material for standard news. There will be no premiums for use of virgin fibre (wishful thinking maybe) higher publication paper grades will switch to more use of virgin fibre.*

[No,] *Paying capability for newsprint is limited [therefore virgin news will no re-appear], however it [decreasing quality of RCP furnish] could have an impact on yield*

[Y/N,] *New technology may ease the situation, e.g. nanofibril-cellulose.*

[No, but the] *Pressure to use RCP in mags and fine will reduce. News will be 100% RCP*

- A9 Share of virgin fibre must globally remain on 20-25% in perfect system.

	<u>Y</u>	<u>Y/N</u>	<u>N</u>	<u>Blank</u>	<u>other</u>
n=	4	1	2	2	0

[Yes,] *Quality of RCP [will limit the usage]*

[Yes,] *minimum [20-25%, could be even more]*

[No,] *Again, not necessarily grade specific. In some grades lower and some higher. in my opinion average must be over 40%,(my feeling).*

[Y/N,] *For graphic papers but not for newsprint.*

[No, this will not in practice limit the RCP utilisation because] *There will be a stream of new virgin fibre capacity. [This comment is more general, not for utilisation in newsprint]*

- A10 First investment decisions in virgin fibre are made Sweden (Holmen TMP) as supply of RCP has become too tight.

	<u>Y</u>	<u>Y/N</u>	<u>N</u>	<u>Blank</u>	<u>other</u>
n=	2	1	5	1	0

[No, it is because of] *Integration to present production and good availability to wood.*

[No,] *SCA Ortviken and Holmens Hallsta & Norrköping have invested in TMP. SCA because fibre supply was felt as a bottleneck, and new technology allowed them to reduce power consumption. Holmen investments were replacement investments motivated by improved quality, improved capacity and energy savings.*

[No,] *Depends on price. Who can afford to produce virgin newsprint in long term? Does the virgin injection go to other grades which are being used in newsprint?*

[N,] *For graphic papers but not for newsprint.*

[N,] *These may be more energy-driven investments. There has been clear improvement in specific energy consumption of TMP-based capacity.*

[Y/N,] *Reason is more local issue. Availability [of RCP] in Sweden is limited and import not profitable.*

A11 An amount of virgin fibre based capacity will remain competitive in Scandinavia and in Russia because of reasonable cost structure.

	<u>Y</u>	<u>Y/N</u>	<u>N</u>	<u>Blank</u>	<u>other</u>
n=	4	3	2	0	0

[Yes,] *Particularly in efficient existing mills.*

Russia yes, Scandinavia no (supply of local RP is limited, thus choice is made between imported RP and local virgin).

[Y/N,] *Russia for some time. Scandinavia??*

[N,] *if you talk about newsprint: maybe Russia not Scandinavia. Virgin fibre based PMs are old and inefficient and have a limited life time.*

[Y/N,] *Rather for Russia than for Scandinavia.*

[Y/N,] *Not in Scandinavia. In Russia yes, but not in the long run.*

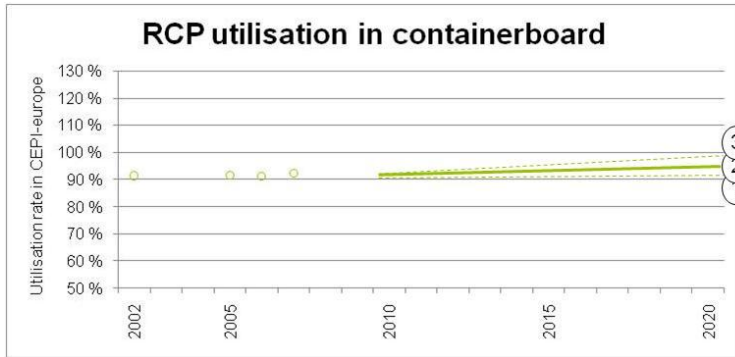

Trend 2. Historical and anticipated development of utilisation-rate of RCP in mfg. of containerboard by the panelists.

Please indicate which of the trends (1/2/3) is closest to your view of future development:

	<u>1</u>	<u>2</u>	<u>3</u>	<u>other</u>
n=	1	6	2	0

Detailed comments:

...or a bit above 2.

All pulp can't be eliminated from the grade structure. [E.g. Food contact and other special products may require no recycled content in the packaging.] Also efficiency of machines might benefit from good enough furnish.

Key arguments in favor of continued growth of uti-rate in containerboards:

A12 Clear cost advantage over virgin fibre (pulp) remains.

	<u>Y</u>	<u>Y/N</u>	<u>N</u>	<u>Blank</u>	<u>other</u>
n=	9	0	0	0	0

[Yes, because of] *high pulp capex.*

A13 Recent evidence are the investment decisions of Propapier Eisenhüttenstadt in Germany, Mondi Swiecie in Poland and SAICA in UK.

	<u>Y</u>	<u>Y/N</u>	<u>N</u>	<u>Blank</u>	<u>other</u>
n=	9	0	0	0	0

- A14 RCP yields will decrease which will have an impact on utilisation rates. (As more RCP is required to produce same amount of product!)

	<u>Y</u>	<u>Y/N</u>	<u>N</u>	<u>Blank</u>	<u>other</u>
n=	9	0	0	0	0

[Yes, but] *only small effect.*

[Yes, because of] *contamination, use of mixed waste.*

- A15 Collection rates are still improving thus creating room for growth in uti-rates (i.e. the market is mainly supply driven).

	<u>Y</u>	<u>Y/N</u>	<u>N</u>	<u>Blank</u>	<u>other</u>
n=	7	0	1	1	0

[Yes, but] *only marginally in Europe.*

[Blank, because] *There is no official methodology to calculate OCC collection rate. What do you mean with supply driven? [See next comment.]*

Containerboard industry is facing soon limits in OCC collection, thus putting increasingly pressure on unsorted household collection --> less ONP&OMG available for graphic paper producers.

Collectin rate is improving YES, [but] I believe in global long term shortage of RCP meaning all increase in utilization rates will be difficult.

[No, because] *Money will run out. [...to perfect the collection systems.]*

[Yes,] *But only in some locations / areas. Growth potential generally fairly small.*

Key arguments in favor of saturation or decline of uti-rate in containerboards:

- A16 RCP prices are on clearly increasing trend as a result of tightening supply. Main reason behind tightening supply include continued growth of utilisation on both local and export markets.

	<u>Y</u>	<u>Y/N</u>	<u>N</u>	<u>Blank</u>	<u>other</u>
n=	9	0	0	0	0

- A17 Growth potential in RCP collection is small and will be the limiting factor in the growth of utilisation.

	<u>Y</u>	<u>Y/N</u>	<u>N</u>	<u>Blank</u>	<u>other</u>
n=	8	1	0	0	0

[Yes, especially because] *China will buy in Europe. [... the growth potential in utilisation is limited]*

[Y/N, because there is] *Substitution between RP grades, solution mixed. [I.e. containerboard manufacturers can utilise MW and ONP/OMG to certain degree and thereby by-pass the collection*

related limitations to certain extent.]

A18 Kraft will keep its position due properties not attainable with RCF.

	<u>Y</u>	<u>Y/N</u>	<u>N</u>	<u>Blank</u>	<u>other</u>
n=	6	1	1	1	0

[Yes,] *Eg vegetable packaging (moisture.)*

[No] *Pricing?* [No because pricing hinders use of kraft in many positions where the properties would prefer its use.]

[Yes, but] *Only modern kraft mills will survive.*

[Y/N,] *Technology may change the situation long-term.*

A19 Share of virgin fibre must globally remain on 20-25% in perfect system.

	<u>Y</u>	<u>Y/N</u>	<u>N</u>	<u>Blank</u>	<u>other</u>
n=	4	0	2	3	0

[Yes, there are] *pockets of virgin fibre (USA, Canada, Russia, Nordics); hornification of fibre when recycled several times* [will limit the usage]

[No, there is] *Substitution between RP grades. Not grade specific. [Overall,] In all paper & board a certain percentage of raw material has to be virgin. Over something??40%?? There is no official methodology to calculate coll rate for an individual RP grade like OCC*

[No,] *MW component in the raw material mix will bring the needed fresh fibre.*

2 Substitute price development

Summary statements (2.1-2,4):

- S2.1 The substitution impact between recycled and virgin fibre is limited in short term but becomes clear in long term.
- S2.2 Price of pulpwood and wood in general is on a rising trend because it is renewable. The CO2-benefits and other taxation effects will come on top of that basic fact.
- S2.3 Development of energy price has a double impact in demand of RCF a) through mfg cost of virgin fibre and b) through fuel value of wood.
- S2.4 In long term the investments in plantation forests in the southern hemisphere and improving economies of scale in chemical pulping will keep the pulp price either declining or only moderately increasing.

Do you in general agree with the summary presented above?

	Y	Y/N	N	Blank	other
n=	9	1	0	1	0

Detailed comments:

Yes, except #3 (in case of chemical pulp). [several panelists commented the same]

S2.1: Yes, as adjustment requires investments.

S2.1: Past investment decisions on pulping lines like TMP/RCF lines slow down long term evident development as they are so capital intensive.

S2.1: Substitution possibilities are limited due to the fact that large parts of the paper industry is located in countries with lack of fibre. China's only option is in principle RCP (news and containerboard)

S2.2: no, renewable [as such] is not a reason for increasing price, it is the risk of increasing demand on renewables [obviously, this was the meaning of the statement]

S2.2: The price of wood and pulp will increase a lot, because wood will replace other materials.

S2.2: [blank] but RCP prices will increase more than virgin fibre long term . It is already with current fibre prices attractive to switch from RCP to virgin in places where this is possible.

S2.3: Mainly increase in energy prices affects the mfg cost of RCF and mechanical pulp, but on the other hand, it may attract the fuel use of wood. [translation]

S2.4: yes, assuming that input prices do not rise too much

S2.4: [It is a question of] SW vs. HW.- [inpact on] HW price moderate, sw perhaps opposite

S2.4: The influence of wood business in the Southern hemispfere will increase but not as much as many will think. Promlems to find land.

S2.4: I rather believe on modestly increasing pulp trend prices as pulp prices might be more impacted by the fact that plantation land is getting more expensive and partly scarce as well. Probably also the best available and cheapest locations are already used, i.e. future locations are not any more so excellent. Also lack of RCP for certain end products (tissue, fine papers, high quality packaging products) might increase pulp demand.

S2.4: Not declining, but moderately increasing only.

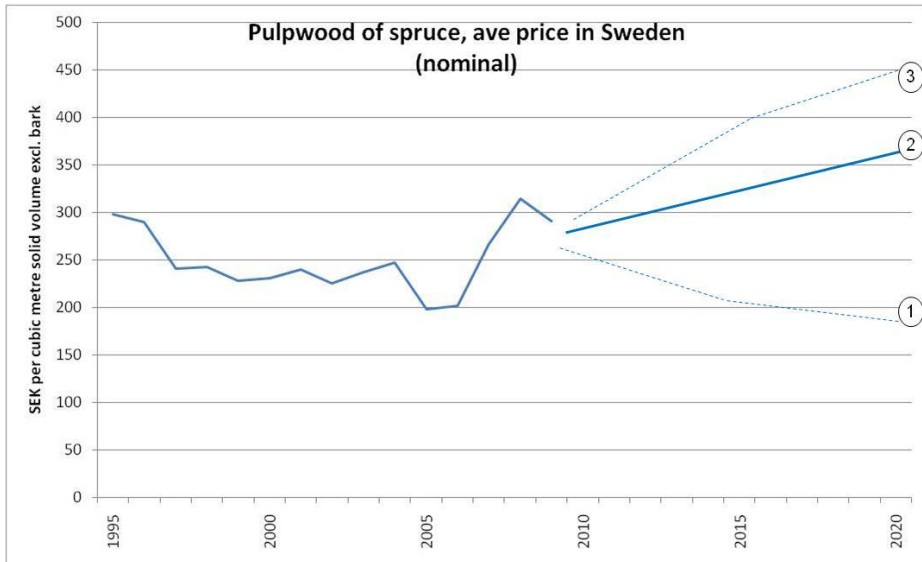

Trend 3. Historical and anticipated development of pulpwood price (spruce in Sweden) by the panelists.

Please indicate which of the trends (1/2/3) is closest to your view of future development:

	<u>1</u>	<u>2</u>	<u>3</u>	<u>other</u>
n=	0	9	2	0

Detailed comments:

[Alt. 2] Indicates some level of real price increase assuming that inflation is around 2%/a.

[Alt 2, but] if the European green energy boom will be politically cancelled, a lower trend is possible but unlike

[Alt 3,] If RES-directive and other similar obligations stay in force.

Key arguments in favor of growth in pulpwood prices:

A20 General competition for biomass for fuel and energy use will push also the pulpwood prices up.

	<u>Y</u>	<u>Y/N</u>	<u>N</u>	<u>Blank</u>	<u>other</u>
n=	11	0	0	0	0

Wood is renewable, EU 20-20 rule. [20% reduction in CO2-emissions by 2020, 20% renewables pushes the prices up.]

If no policy limitation for pulp wood to energy, marginal price of bioelectricity is competitive with wind +[in addition] boom for BTL will be seen [BTL=Biomass to liquid-transportation fuels]

Shortage [of wood will push prices up].

A21 Cultivation projects of fast growing biomass for fuel use are being planned.

	<u>Y</u>	<u>Y/N</u>	<u>N</u>	<u>Blank</u>	<u>other</u>
n=	9	0	1	1	0

I don't understand how this increases wood price. [Correct, it should have a balancing effect if alternative biomass supplies emerge and thus ease the pulpwood market !]

Yes, agrobiomass give higher yield [This may serve as a general indication of business potential in the bio-fuel market?]

[Yes,] but not so much [indicating that fuel wood is still cheaper alternative??]

E.g. Aracruz does this at their plantations under the Euca-trees.

A22 Suitable land area is or will become limited and price of forest area will increase as well thus pushing the wood price up.

	<u>Y</u>	<u>Y/N</u>	<u>N</u>	<u>Blank</u>	<u>other</u>
n=	10	0	0	1	0

[Yes,] Particularly, if the world will follow new IEA scenario 450.

Production of food depends on fossile fuels (in USA ten units of fossile energy needed to eat one unit). The less fertilizers, the more land you need. [So a double risk!?!]

A23 There are increasing subsidies on energy use of biomass.

	<u>Y</u>	<u>Y/N</u>	<u>N</u>	<u>Blank</u>	<u>other</u>
n=	9	0	1	1	0

Yes, EU rule 20-20.

[Yes,] assuming that RES targets hold.

[No,] though in some countries yes, hopefully declining.

[Yes,] In Europe you get votes with it.

[Yes,] Already today we anticipate unhealthy competition of wood utilization for energy

generation in comparison to product manufacturing i.e. value creation. [Therefore can't increase anymore!]

[Yes,] Not increasing, stable [high] !

- A24 The forest owners will welcome the good side revenue from energy wood and will actively work for it thus working in favor of development of fuelwood market.

	<u>Y</u>	<u>Y/N</u>	<u>N</u>	<u>Blank</u>	<u>other</u>
n=	8	0	2	1	0

[Yes, it is] *double advantage, you get money for side products and can get the price of normal products up because of competition.*

[No,] *Depending on subsidy schemes.*

[No,] *if price of energy wood increased, more of it will be placed for sale. On the other hand, it will be away of pulp wood supply, so it will not benefit the forest owner, unless the price increased. If price increases too much, the demand will decrease. [So end result is small, provided that price elasticity of pulp wood demand is significant. On this, there are mixed opinions.]*

- A25 Structure of forest ownership is further fragmenting which makes it less attractive for forest owners to make fellings thus reducing supply.

	<u>Y</u>	<u>Y/N</u>	<u>N</u>	<u>Blank</u>	<u>other</u>
n=	9	0	0	2	0

[Yes,] *at least in Finland.*

- A26 Strong northern fibre will be needed in paper products in future as well. Also new purposes for Nordic soft wood may emerge. There is ultimately paying capacity for the good fibre, i.e. demand as pulpwood is less elastic as anticipated.

	<u>Y</u>	<u>Y/N</u>	<u>N</u>	<u>Blank</u>	<u>other</u>
n=	10	1	0	0	0

[Yes] *Softwood kraft demand is not growing (except for fluff products) but it will be needed in the future, no doubt. Fibre paying capability is another question which may require an answer NO. Paper industry profits are so low that willingness to pay is low. This does not change the assumption that pulpwood demand is not elastic.*

[Yes, but] *how high is this premium in future products ? [Not very high, based on comments of other respondents.]*

[Yes, it] *is needed for production of publication paper (magazine) to get strength. Also for other grades requiring strength.*

[Y/N] *of course here in North we'd welcome such development, and it is evident to some degree. However, there are limits to such development. Weak producers [of NBSK] will certainly drop from the competition. [The question remains, how high/low is the elasticity in pulp demand. In certain*

economic studies, it has been found out to be relatively low, higher than of wastepaper, though.]

A27 TMP might stop losing market share as RCP supply becomes tighter and prices increase.

	<u>Y</u>	<u>Y/N</u>	<u>N</u>	<u>Blank</u>	<u>other</u>
n=	7	1	2	1	0

[No,] *very limited* [impact].

[Yes,] *I agree, price of electricity crucial for tmp.*

[Y/N] *How much is the difference when electricity and wood prices effect TMP vs RCP price increase?* [Difficult question.]

[No,] *TMP will loose market share* [this is evident] *because RCP consumption is still increasing at a much stronger phase then virgin fibre. EU stagnating – China strongly increasing and than mainly in RCP.* [This is the situation today, but will it change?]

Key arguments in favor of saturation or decline in pulpwood prices:

A28 There is significant elasticity in pulpwood demand. I.e. pulpwood demand in fibre use will decrease if prices increased a lot.

	<u>Y</u>	<u>Y/N</u>	<u>N</u>	<u>Blank</u>	<u>other</u>
n=	5	0	6	0	0

[No. There is] *No alternative, higher wood prices will increase supply.* [In other words, it is suggested that there is considerable price elasticity in supply!]

[No] *Long run elasticity is of course higher than short run elasticity, but in general demand for intermediate goods tends to be price inelastic. A drop in the price of steel would not cause car manufacturers to buy more steel.* [In economics literature pulp demand is found out to have somewhat more own-price elasticity than wastepaper does. Still it is low, generally speaking.]

[Yes] *agree – production to be built in Brazil etc.* [In fact, this would be an indication of supply side elasticity.]

[No] *Paper industry is not ready to say to it's customers it cannot deliver paper as pulpwood is too expensive. Finally demand from printing plants/publishers will set the right level of pulpwood prices as they pay more for their paper and paper industry's paying capability improves.*

[No, there is] *stable consumption due to lack of substitutes.*

[Yes] *Elasticity is existing, but is moderate.*

[Overall comment: despite several Y-answers, there is sort of an agreement within the panelists

(and literature) that own-price demand elasticity of pulp is very low in short-term, but there is, of course, a good amount of long-term elasticity.]

- A29 Demand will grow modestly if at all. E.g. rising electricity prices will curtail pulpwood demand for TMP.

	<u>Y</u>	<u>Y/N</u>	<u>N</u>	<u>Blank</u>	<u>other</u>
n=	8	1	1	1	0

Yes, if demand for printing papers continue to decline.

Clear yes for the first statement. The second one is arguable because end product demand is much more important than changes in any prices of production factors.

[Y/N, price of electricity has] *Some influence.*

[No] *Look at Kerava "pulp mill" for an example of roundwood consumption at power plant! [i.e. decrease in pulpwood consumption is easily set-off by increase in fuel wood consumption. Therefore total demand will keep growing.]*

- A30 Increasing [demand in] energy use will be balanced out by decrease in paper production. [Thus total demand is not growing.]

	<u>Y</u>	<u>Y/N</u>	<u>N</u>	<u>Blank</u>	<u>other</u>
n=	2	0	7	2	0

[No,] *paper for replacing plastics in packaging will increase.*

[No,] *There are other end uses for wood fiber as well.*

[No,] *There will not be so quick decrease in paper production.*

[There were several misunderstandings of this argument. Only comments relevant to original meaning of the A30 are included here.]

- A31 [Increase in the demand of fuel wood is not relevan] In Nordic [as] the fuel use is small in comparison to fibre use. Therefore fuel price has little impact. The situation is completely different in Central Europe where fuel use is more significant.

	<u>Y</u>	<u>Y/N</u>	<u>N</u>	<u>Blank</u>	<u>other</u>
n=	5	2	2	2	0

[No,] *the fuel use in the Nordic will also increase.*

[Yes, there is significant growth in Central Europe also because] *Private household are investing in fire places a lot as fuel/gas is getting more expensive. For gas there is on top of that the "Russian" supply risk, and gas supply from Russia to Europe was closed for many days in 2008-2009.*

[No,] *Not true anymore. See Kerava for example. Also Helsinki city is planning to combust 2 Mm3 annually by 2020.*

- A32 Society can't afford the large scale fuel use of pulp wood. The required subsidies would be substantial – on top of the reduction in the output of various forest products.

	<u>Y</u>	<u>Y/N</u>	<u>N</u>	<u>Blank</u>	<u>other</u>
n=	7	1	2	1	0

[Yes, because] *Wood is more valuable as raw material for products than for energy.*

[Y/N] *depends on scenarios; higher oil price 150 \$ will boost wood to energy and CO2 price. Unclear predictions. Subsidies are much smaller than for wind [per] MWh.*

[No,] *The pulp wood will be used for energy, also. But higher price will bring more wood to the market.*

[No,] *Payment capability will decide for which use pulpwood is finally channeled. There is room for all end uses, it just requires better industry/European wide optimization from the companies and government.*

- A33 Ample availability of short fibre from Southern hemisphere will reduce pulpwood demand in Nordic countries.

	<u>Y</u>	<u>Y/N</u>	<u>N</u>	<u>Blank</u>	<u>other</u>
n=	4	0	7	0	0

[No,] *Birch has quality advantage in certain paper grades, birch pulp cheaper than long fiber pulp.*

Weak yes. What about long fibre, does it suffer from southern short?

[No,] *Long fibres are needed [in future as well].*

[No,] *Pulpwood demand/supply balance will keep tight due to new end uses (biomass, wood products etc.)*

[No,] *Both are needed. [i.e. southern and nordic fibres. Therefore pulpwood demand will stay in Nordic as well.] -> several panelists shared the same comment.*

- A34 Swedish production cost structure is favorable for TMP. A lot of hydro and nuclear power together with ample CO2 credits will keep electricity prices reasonable. Paper mills are also quite self sufficient in resources.

	<u>Y</u>	<u>Y/N</u>	<u>N</u>	<u>Blank</u>	<u>other</u>
n=	7	1	2	1	0

[No,] *Sweden will sell its electricity to Germany.*

[No,] *Higher paying capability for other end uses , if there will be a European market for electricity, selling electricity will be more attractive.*

[Y/N,] *The argument is in wrong place. If Swedes really had attractive production cost structure for*

TMP, it would mean more paying capability for wood, thereby potentially increasing the demand and prices. [Correct, and all in all the panelists seem to somewhat agree that there is potential cost increase also in Sweden for pulpwood.]

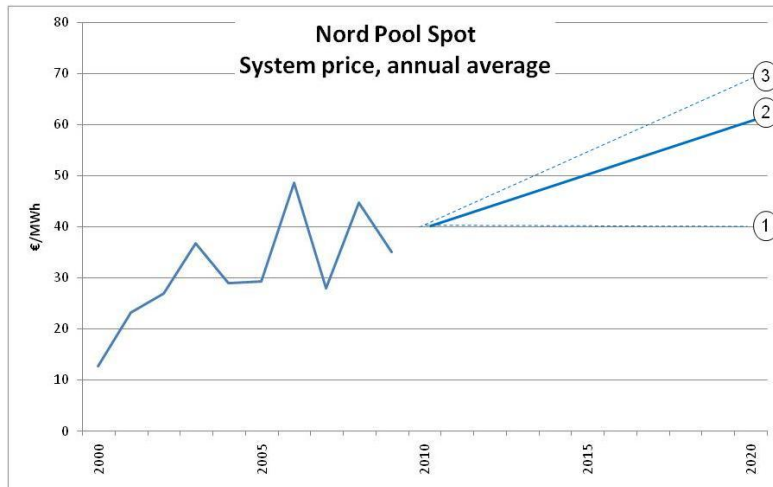

Trend 4. Historical and anticipated development of electricity (Nordpool spot, annual average, nominal) by the panelists.

Please indicate which of the trends (1/2/3) is closest to your view of future development:

	<u>1</u>	<u>2</u>	<u>3</u>	<u>other</u>
n=	0	8	1	1

Detailed comments:

[Other] *The el price in Scandinavia will be polarised, so in the winter we will have very high prices and the average price of winter time will be 2-3 times higher than today but in the summer time the average price will go down. The reason is the use of el for heating and atomic power plants. Today during cold days over 50% of el goes for heating in Finland. In the future much more. There is no technology to meet this demand.*

The cable connection to central Europe will increase market prices.

[Especially industrial] *Demand will decrease if price increases too much.*

Key arguments in favor of growth in electricity price:

- A35 There are major investments (and plans) in electricity production capacity in Nordic. If exports and consequent transfer capacity were politically accepted and built, increase in prices to Central European level would be witnessed.

	<u>Y</u>	<u>Y/N</u>	<u>N</u>	<u>Blank</u>	<u>other</u>
n=	6	2	1	2	0

[No,] *markets will remain separate.*

[Y/N] *Not clear statement (again). If there will be investments in low cost energy in Nordic (hydro, nuclear), one could assume that price increases remain weak. If investments are made for burning moss and lichen [meaning low calorific, inefficient biomass in general], the prices will increase and prosperity will not develop. If exports and export capacity are being build, it can cause changes in either direction, depending on scale of transfer investments in relation to actual transferred MWh. Naturally building transfer capacity has little to do with price development in Central Europe – there can happen also something else [than constant increase].*

Agree – connections are ready to operate [an amount of transfer capacity already exists.]

[Y/N,] *Yes, but it takes more than 10 yrs [to realise the transfer capacity needed.]*

- A36 Electricity consumption will continue to grow. Eventually in transportation as well.

	<u>Y</u>	<u>Y/N</u>	<u>N</u>	<u>Blank</u>	<u>other</u>
n=	9	0	1	1	0

[Yes, it follows] *Growth in GDP.*

Agree, also in heavy industry.

[Yes, and] *the use of el will not be even [around the clock, around the year] and this makes it even more difficult. [And causes further pressure to increase prices]*

[No,] *Efficiency improvements for energy consumption will continue.*

- A37 New capacity will increase the prices due heavy investments and Carbon Capture obligations. Impact of the later has been estimated to be +50 €/MWh in coal fired condensate.

	<u>Y</u>	<u>Y/N</u>	<u>N</u>	<u>Blank</u>	<u>other</u>
n=	8	0	0	3	0

[Yes,] *Carbon Capture and Storage in existing utilities; IEA study 4..8-10 c/kWh.*

- A38 [There will be increasing] Energy taxation (in its different forms) [that] will further increase the prices.

	<u>Y</u>	<u>Y/N</u>	<u>N</u>	<u>Blank</u>	<u>other</u>
n=	10	0	0	1	0

[Yes,] *Governments need money.*

[Yes,] *Politicians want renewable energy and it is expensive. It is easier to tax old production than give subsidies to new ones.*

Yes in general- not very much [increases] for industry.

- A39 Photovoltaics and renewable energy will call for rather high price level in order to develop. There is political will to ensure their development.

	<u>Y</u>	<u>Y/N</u>	<u>N</u>	<u>Blank</u>	<u>other</u>
n=	9	0	0	2	0

[Yes, evidence are] *EU 20-20 targets.*

Yes – or investment grants for market introduction.

Key arguments in favor of saturation or only slight growth of electricity prices:

- A40 A drop in demand is foreseen as major closures of mechanical pulping capacity are expected in time frame up to 2020. Also other industrial consumption in Nordic might turn into decline.

	<u>Y</u>	<u>Y/N</u>	<u>N</u>	<u>Blank</u>	<u>other</u>
n=	4	0	5	2	0

[No,] *If GDP continues to increase, el-demand will follow.*

Yes, concerning mec pulp, maybe concerning the 2nd part.

[No,] *I would expect TMP will continue.*

[No,] *mining industry is growing --> increase in steel/metal production to offset possible decline in other areas.*

[No, it] *Depends if industrial activity will sustain in Nordic. There might become a step change / decline at some point if industry escapes. This might lead into a vicious circle when critical mass to sustain different types of infrastructure and education vanishes.*

- A41 New investments in nuclear power plant capacity will prevent large price increases.

	<u>Y</u>	<u>Y/N</u>	<u>N</u>	<u>Blank</u>	<u>other</u>
n=	4	3	2	2	0

[Yes, because of] *Demand / Supply balance.*

[Yes,] *Assuming that marginal producers will be bio-based power producers. [??]*

[Y/N] *will be seen, also argumentation for higher investments [of nuclear, meaning pressure to increase prices]*

[Y/N] Yes, if there won't be enough transfer capacity to Central Europe.

[No] In Finland we need today 7500 MW el for heating during cold days. In the future even more (heat pumps do not work when cold). In Sweden and Norway even more. Nuclear is no tech for heating.

[Y/N] It can temporarily prevent large price increases, but not in the long run.

A42 If the unification of European electricity markets will not take place, electricity price is likely to stay flat (based on development of local demand / supply balance in the Nordic market).

	<u>Y</u>	<u>Y/N</u>	<u>N</u>	<u>Blank</u>	<u>other</u>
n=	7	1	1	2	0

[No] Never enough transfer capacity for special days. [There will be peaks, of course, but the argument is that trend price will stay flat.]

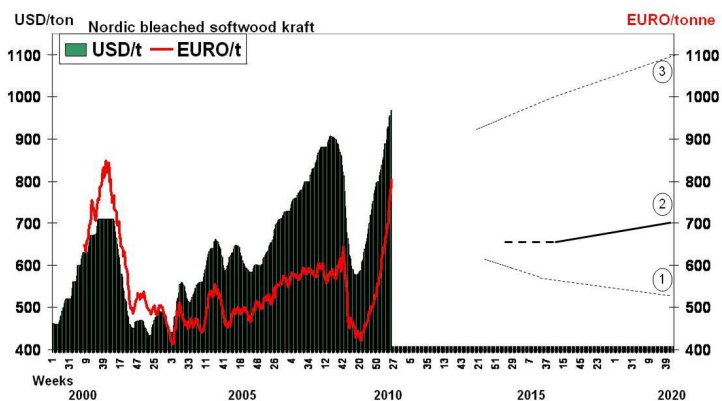

Trend 5. Historical and anticipated development of bleached softwood kraft pulp by the panelists (nominal, in US\$).

Please indicate which of the trends (1/2/3) is closest to your view of future development:

	<u>1</u>	<u>2</u>	<u>3</u>	<u>other</u>
n=	0	7	1	2

Detailed comments:

[1/2] Between 1/2, not declining, however.

[2/3] global fibre shortage will increase the price of all fibres long term.

Prices tend to increase a bit due to inflation (around 2%/a). Real price trend will show a marginal decline due to limited/no growth of BSKP demand + substitution effect from BHKP/Euca, and exit of high-cost marginal producers+ possible entry of low-cost supply from Russia.

Trend price in my mind little bit higher, 800-900 eur/t.

Key arguments in favor of increasing pulp price:

- A43 The general competition for biomass will keep also the pulp prices relatively on a higher level. E.g. use of fuel wood will increase thus tightening the supply. It also means that the long-term historical price trend of decreasing pulp prices [in real terms] will come to an end.

	<u>Y</u>	<u>Y/N</u>	<u>N</u>	<u>Blank</u>	<u>other</u>
n=	7	1	2	0	0

[No,] Demand for pulp will grow slowly or nor at all.

[Y/N] The production volumes of NBSKP for market will decrease. [Should increase the prices unless demand of market pulp decreases as well.]

[Yes,] Biorefinery concept will emerge at pulp mills. It provides the operator flexibility to optimise between different outputs based on demand/price situation. Thus keeping the pulp prices high. [also in the moments of weak pulp demand!]

- A44 Significant share of RCF is used as biofuel is some form.

	<u>Y</u>	<u>Y/N</u>	<u>N</u>	<u>Blank</u>	<u>other</u>
n=	2	3	5	0	0

[Y/N] long term possibly but unlikely.

[No, because] boilers will need to change; single stream collection of waste would result in paper being burned instead of recycled; recycling hierarchy would support recycling before incineration.

[Y/N] Not as a separately collected, co-mingling as energy use of combustible waste [is possible and would mean energy use of a certain amount of discarded paper in wastes.]

[Yes,] to make fuel for cars of RCF is acceptable.

[No, because] RCF is channeled primary to paper making. Biofuels are made from forest residuals and lower grade pulpwoods. This development is partly driven by EU legislation... (reduce, reuse, recycle, burn, landfill).

[No, but] could be fibres from commingled collection systems which are cheap. Not likely that standard RCP grades will be burned.

[No,] Without subsidies, paying capability for biofuels shouldn't be good enough.

[No,] *Some portion, but not significant?*

[Y/N] *Only some amounts.*

A45 Increase in fibre based packaging will keep demand on a growth track.

	<u>Y</u>	<u>Y/N</u>	<u>N</u>	<u>Blank</u>	<u>other</u>
n=	9	1	0	0	0

[Yes,] *Fibre based packaging is renewable and will therefore grow.*

[Y/N] *but primarily RCP is used, could indirectly also affect pulp.*

A46 Reinforcement pulp will be needed in future as well. Thus no decline in demand.

	<u>Y</u>	<u>Y/N</u>	<u>N</u>	<u>Blank</u>	<u>other</u>
n=	8	1	1	0	0

[Yes,] *but perhaps slow [decline will take place].*

[No,] *Demand for reinforcement pulps will decline because of declining graphical paper production. [Same comment by several panelists.]*

A47 Pulp lives in connection to other raw materials, thus a rising trend. [In this argument there was too ambiguous wording. The meaning of this statement is that by 2020 the general trend in prices for raw materials is clearly rising as the global growth is likely to be strong.]

	<u>Y</u>	<u>Y/N</u>	<u>N</u>	<u>Blank</u>	<u>other</u>
n=	6	0	3	1	0

[No,] *Demand depends on Printing & Writing papers.*

[No,] *Pulp prices are connected to end product markets that are anyhow on a declining trend.*

[Yes,] *Due to substitution with other scarce fibers, also pulp d/s balance getting more tight --> higher prices.*

Slightly yes. [More pulp is] required through some increase in finepaper production in the developing world.

Key arguments in favor of flat or decreasing pulp prices:

A48 Increase in low cost pulping capacity in southern hemisphere (low raw material cost and economy of scale; also logistics will keep improving). Also hardwood will keep increasing its market share over softwood.

	<u>Y</u>	<u>Y/N</u>	<u>N</u>	<u>Blank</u>	<u>other</u>
n=	7	1	2	0	0

[No, because] *not so much land available.* [Several panelists had the same comment.]

[Y/N] *SW and HW pulp prices will divert from each other more.*

A49 The demand in long term is not increasing that much. I.e. increasing the chemical pulp supply has no difficulties to match the increases in demand. Market behaves very logically, following changes in demand, supply and inventories.

	<u>Y</u>	<u>Y/N</u>	<u>N</u>	<u>Blank</u>	<u>other</u>
n=	6	0	4	0	0

[No, because] *paper will replace plastics, glass and metal in package.*

[No,] *Fiber packaging and tissue demand will boost pulp demand. Also Asian fiber poor regions produce their graphic papers mostly based on pulp.*

[No,] *Biorefinery concept will emerge at pulp mills. It provides the operator flexibility to optimise between different outputs based on demand/price situation. Thus drop in demand will be easily compensated by diverting capacity to other outputs.*

[No] *Demand in Asia will exceed the supply - also in the long run.*

A50 Hardwood price will decrease due plantations and economy of scale - the price gap between HW/SW will probably grow.

	<u>Y</u>	<u>Y/N</u>	<u>N</u>	<u>Blank</u>	<u>other</u>
n=	7	1	2	0	0

[No] *Global fibre shortage in som years will keep prices for all fibres high.*

A51 Demand in long term will decline.

	<u>Y</u>	<u>Y/N</u>	<u>N</u>	<u>Blank</u>	<u>other</u>
n=	2	0	7	1	0

[Yes, but] *very long term.*

[No,] *market pulp continues to grow because it is cheaper to produce pulp in L. America than in Europe. It is also the cheapest form of fibre (logs/chips and paper more expensive to transport.*

[No, pulp will be] *replacing other materials.*

[No,] *Growth is needed in all fiber grades in order to match the increasing paper&board*

production fiber demand.

[Demand will] *stagnate or decline due little growth in demand for the end products.*

[No,] *other end uses than graphic papers will increase, e.g. hygiene paper and packaging.*

[No,] *not with this time horizon [up to 2010] but later, perhaps.*

[No,] *Increasing paper capacity, especially in Asia will keep the demand increasing.*

3 Supply development, i.e. development of RCP collection rate

Summary statements (3.1-3.3):

- S3.1 Though there remains both political and demand pressure to increase the collection rates they are estimated to saturate soon. Some 5-10%, in maximum, is attainable on global scale.
- S3.2 Development of collection systems towards commingled collection will increase the supply of mixed grades, thus bringing further difficulties to manufacturers of graphic grades.
- S3.3 Development of collection systems will bring more flexibility for the operators to optimise between fuel and fibre market. This is likely to create conflicts of interest between collection operators and paper industry.

Do you in general agree with the summary presented above?

	Y	Y/N	N	Blank	other
n=	6	1	1	0	0

Detailed comments:

Globally, 10-20% units up as maximum rather than 5-10%. The latter may apply to Europe.

S3.1: This is a difficult question. Different areas are at different phases re: collection rate and collection systems. This depends on the level of paper consumption (overall and per capita). To get an accurate collection figure, one should analyse each area in detail. One particular problem is that present collection or recycling rates are not properly reflecting reality. European collection rate 2009 of 72,2% is quite high in my opinion. Because of "error" in the calculation method the present figure might be actually be the maximum. [Meaning that maximum of collection rate when calculated correctly is probably close to the figure of present calculation that contains certain error. The error is because exports and imports of paper products with other goods are not correctly included in the calculation.]

S3.1: [No,] The collectin rate will go to 80% all over.

S3.1: The collection rate is relatively high and can only be raised up some small prosentage.

S3.2: [No,] The mixed grade will increase a lot. [Thus enabling the high collection rate.]

S3.2: [Y/N] The commingled collection will be best at remote areas, but when industry sees that material is not as good Industry will/shall pay more from sorted collection material and so collectors will try too keep sorted collection when it's possible related to collection cost.

S3.2: The paper industry will have to cope with lower quality through commingled collection systems and they will find ways to control quality – so not big problem.

S3.3: [No,] There will be conflicts. (The way of thinking: The paper industry still wants all the collected paper to local industry, no wood for energy by other players and the devaluation of the currency)

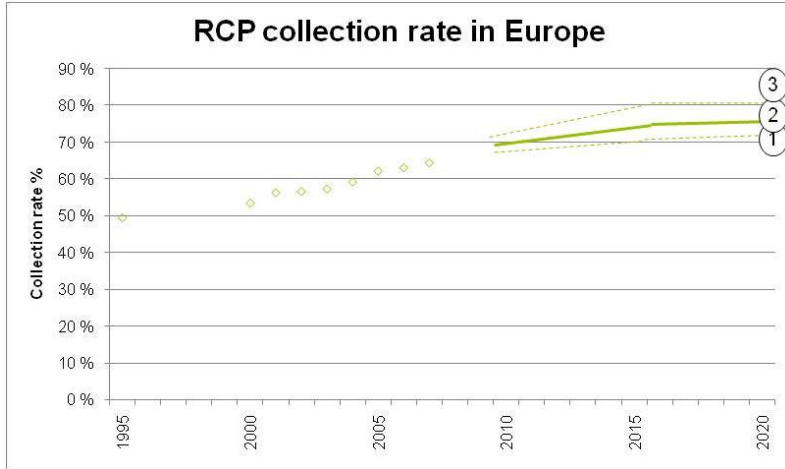

Trend 6. Historical and anticipated development of RCP collection rate by the panelists.

Please indicate which of the trends (1/2/3) is closest to your view of future development:

	<u>1</u>	<u>2</u>	<u>3</u>	<u>other</u>
n=	1	4	3	0

Detailed comments:

[Alt. 2] Please note, that the calculation method contains sources of error.

Key arguments in favor of strong/fair growth in collection rate:

A52 Collection rates keep still improving as higher and higher mandatory requirements are set by authorities.

	<u>Y</u>	<u>Y/N</u>	<u>N</u>	<u>Blank</u>	<u>other</u>
n=	6	1	1	0	0

[Y/N] Partly. Demand side is more important [than authority requirements.]

[No,] The level in Western Europe is already so high that there is not much space for improvement.

[Yes,] to a certain point after which it cannot improve.

A53 High price level of RCP creates an incentive to sort and improve collection systems.

	<u>Y</u>	<u>Y/N</u>	<u>N</u>	<u>Blank</u>	<u>other</u>
n=	7	1	0	0	0

[Y/N] Incentive to sort is only dependant on the gap between deinking grades and mixed RCP, improve collection systems: yes.

A54 People have genuine interest to sort their wastes thereby gradually increasing the collection.

	<u>Y</u>	<u>Y/N</u>	<u>N</u>	<u>Blank</u>	<u>other</u>
n=	5	1	2	0	0

[Yes,] partly due to environmental thinking and authority actions.

[Y/N] LCA and other studies indicate that commingled is also environmentally sound system.

[Yes,] This is partly cost driven, however mostly a question of people's behaviours. German and Finns tend to sort, but in Spain and Italy less.

[No, because] 1) people will follow the available collection system on place 2) commingled collection systems creates higher output of paper then segregated systems in the end.

[No,] Depends on how comfortable the collection system is for the consumer.

A55 Collection systems keep improving (bin at homeyard increases sorting-%).

	<u>Y</u>	<u>Y/N</u>	<u>N</u>	<u>Blank</u>	<u>other</u>
n=	7	0	1	0	0

Yes, increased commingled collection (depends what you mean by improving) [Improved collection systems bring higher collection rate or lowers the marginal cost. I.e. The curve S_{RCP} moves right by the improvements in collection systems. E.g. commingled collection is expected to act this way.]

A56 China's demand will keep pulling EU supply.

	<u>Y</u>	<u>Y/N</u>	<u>N</u>	<u>Blank</u>	<u>other</u>
n=	7	1	0	0	0

[Y/N] demand of good quality RCP will be present at China. Closings of virgin fibre supply will affect RCP quality in future. [I.e. poor quality of RCP might drive Chinese to virgin fibre.]

A57 New countries will step-up their systems to Western European standards.

	<u>Y</u>	<u>Y/N</u>	<u>N</u>	<u>Blank</u>	<u>other</u>
n=	7	1	0	0	0

[Yes,] Eastern European countries perhaps, but in many other countries with lower per capita paper cons. must create other functional systems.

[Y/N,] it takes time.

[Yes,] *Especially China in some time.*

[Yes,] *Not in the short-run – will take time.*

Key arguments in favor of rapid saturation in collection rate:

- A58 The potential simply is not that high anymore and natural, rational maximum level will be soon reached.

	<u>Y</u>	<u>Y/N</u>	<u>N</u>	<u>Blank</u>	<u>other</u>
n=	6	1	1	0	0

[Y/N] *In Western Europe yes, other regions – case by case.*

[No, there is still potential because] *most countries still below 80%.*

[Yes] *but there are still potentials.*

- A59 Technical maximum is reached soon (already 2015).

	<u>Y</u>	<u>Y/N</u>	<u>N</u>	<u>Blank</u>	<u>other</u>
n=	5	0	2	1	0

In some countries: YES. However, Europe as a whole NO as further potential in EE & South Europe exist.

[Blank, it depends on how you define] *what is technical maximum collection rate?* [Typical figure in literature is 80%. Meaning that tissue papers, cigarette papers and similar specialities as well as net increases in archives are reduced from paper consumed.]

[No,] *only in some countries.*

[Yes,] *In developed countries, but not in emerging countries.*

- A60 In many EU countries there is slow development (e.g. FR, IT, Eastern Europe)

	<u>Y</u>	<u>Y/N</u>	<u>N</u>	<u>Blank</u>	<u>other</u>
n=	5	0	3	0	0

[No,] *Italy in fact fairly rapid; EE ,too.*

[Yes,] *Peoples' motivation not high enough.*

[No,] *Money talks. [No other incentive to sort.]*

[Yes,] *people are not used to recycle in a way like the best countries (japan, Germany) do. To learn it, will take time.*

[No,] *Development has been improving significantly*

A61 Almost all remaining potential lies with household collection. It is however expensive to expand into rural areas.

	<u>Y</u>	<u>Y/N</u>	<u>N</u>	<u>Blank</u>	<u>other</u>
n=	7	0	1	2	0

[Yes, rural collection forms] *marginal costs* [of RCP supply].

[No,] *There will be less and less* [collection in] *rural areas because of high oil prices.*

A62 As sophisticated collection systems like in Germany will not be built anymore.

	<u>Y</u>	<u>Y/N</u>	<u>N</u>	<u>Blank</u>	<u>other</u>
n=	3	0	5	0	0

[No,] *Collection systems develop if raw material sourcing requires it.*

[No,] *There are several systems in germany, too. Some of these systems may be adjusted to suit to some other countries.*

[Yes,] *It is too expensive.*

[No,] *German collection system was too heavy and modern at that time as proper sorting plants were not in place. Better sorting technology enables other countries to establish a more simple collection system reaching the same overall collection rates, however with smaller investment costs. [Means that as good collection rates will be achieved, though with simpler system.]*

[Yes,] *commingled is easier.*

[No,] *Depending on price development.* [High price may justify complicated and expensive collection.]

A63 Energy use, i.e. co-combustion is eating up some of the growth potential.

	<u>Y</u>	<u>Y/N</u>	<u>N</u>	<u>Blank</u>	<u>other</u>
n=	8	0	0	0	0

[Yes,] *especially when it affects peoples interest in sorting at all.* [Which would be the extreme consequence.]

Part of paper can be channeled to energy- use if it is difficult to sort out.

Most likely at least in some years time.

4 Market development related to energy utilisation of RCF

Summary statements (4.1-4.4):

- S4.1 Based on the current and forecasted price difference of RCP and different bio-fuels, there is very small risk that standard RCP grades would go into fuel use in West Europe.
- S4.2 There is a clear trend of building waste-to-energy power plants at paper mill sites and for certain other industrial uses. As increasing use of waste-to-energy will eat up some of the future growth potential from RCP supply, this trend will have at least indirect impact in prices and quantities of RCP.
- S4.3 Strong political push behind renewable energy and biomass in particular will cause at least a small disturbance on the RCP market (e.g. in form of CO2-credit benefits).
- S4.4 Technical development in waste-to-energy (and biomass based energy in general) remains a wild card in future speculations. There are arguments and opinions for and against of it having a big impact.

Do you in general agree with the summary presented above?

	Y	Y/N	N	Blank	other
n=	9	0	0	0	0

Detailed comments:

Urban Mill concept would additionally offer a happy marriage with paper and waste management/energy industry. It can get additional fibre from landfilling and mass incineration plants.

The energy use will sooner or later be integrated with material recycling. They will support each other.

Price development in CO2-trade

During first round majority of panelists believed that price level of CO2-credits will increase to a rather high level, 30-35 €/t, and even up to 50 €/t by 2020. Some predicted fairly stable level of 20 €/t to last for the whole decade. A couple of panelists considered that the whole system might collapse or radically change by 2020.

Following new comments were received in the second round questionnaire:

If [by] 2050 up to 80 % GHG reduction is needed in OECD countries, this would mean 80 – 120 €/t CO2. This scenario should be kept in mind for normal new industrial investments with 20 years life time.

20 €/t seems to be too low to reduce the actual emissions.

It will increase in a linear way from 15 to 50 euros by 2020.

30€/t by 2030; 25 €/t by 2020 (latest IEA-report) [IEA is often referred to having had accurate forecasts.]

Key arguments in favor of high price level of CO2-credits:

A64 It is a prevailing expert opinion of the market development. E.g. IEA has predicted a price level around 50 \$/t in 2020. (IEA World Energy Outlook, 2009).

	<u>Y</u>	<u>Y/N</u>	<u>N</u>	<u>Blank</u>	<u>other</u>
n=	4	1	0	1	0

[Y/N] *if industrial world can keep the targets and act ?*

[Yes,] *IEA is almost always right.*

A65 -20% target in EU's CO2-emissions calls for rather high price level.

	<u>Y</u>	<u>Y/N</u>	<u>N</u>	<u>Blank</u>	<u>other</u>
n=	5	1	0	0	0

[Y/N] *if new large scale nuclear is not acceptable.*

A66 Global cap&trade actions are likely after 2015 and they will push the price level up.

	<u>Y</u>	<u>Y/N</u>	<u>N</u>	<u>Blank</u>	<u>other</u>
n=	5	1	2	0	0

[No, cap & trade is] *No global business.*

[No, because] *US in key role. Not likely to find political agreement to comply with cap & trade.*

[In fact, emergence of functioning global cap&trade system would most likely lower the CO2-credits price as the most effective actions would be realised.]

Key arguments in favor of low price level of CO2-credits:

A67 EU target of -20% is very speculative. Credits are dealt out generously at the moment.

	<u>Y</u>	<u>Y/N</u>	<u>N</u>	<u>Blank</u>	<u>other</u>
n=	1	0	3	2	0

[No,] *Target is still very true in EU.*

[No,] *Allowances would be [running] short if economy [was] normal*

[No,] *Energy and climate change related objectives have high political priority.*

A68 Political pressure, i.e. weak economy and "carbon escape" (industry escaping Europe) will keep the price level low.

	<u>Y</u>	<u>Y/N</u>	<u>N</u>	<u>Blank</u>	<u>other</u>
n=	2	0	3	1	0

... or postpone actions.

[No,] *Some industry sector might get some help in CO2 but e.g. energy sector is not competing against China and others.*

[No,] *no remarkable escaping.*

[Yes,] *One should not forget that in China low carbon economy is favored because consumers want that. Environmental catastrophes are there so threatening and evident.*

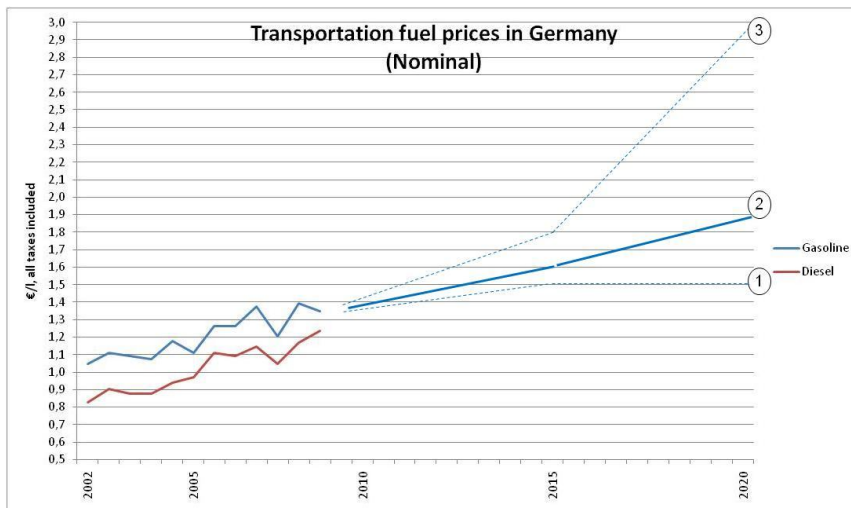

Trend 7. Historical and anticipated development of transport fuel prices by the panelists (nominal).

Please indicate which of the trends (1/2/3) is closest to your view of future development:

	<u>1</u>	<u>2</u>	<u>3</u>	<u>other</u>
n=	0	7	1	0

Detailed comments:

[Alt. 2] IEA 2030: 130 €/barrel.

Key arguments in favor of strong growth in fuel prices:

A69 There are limited reserves of oil, i.e. peak oil is either at hand or has already passed.

	<u>Y</u>	<u>Y/N</u>	<u>N</u>	<u>Blank</u>	<u>other</u>
n=	7	0	0	0	0

IEA: 2015 [in 2010 report]

A70 Demand development in Asia, particularly China, is too strong to be met by supply. Chinese already buy more cars than US but the difference is that the whole amount is absolute growth in China whereas in US roughly same amount of cars are scrapped as purchased. The effect of increasing motoring in China will be huge.

	<u>Y</u>	<u>Y/N</u>	<u>N</u>	<u>Blank</u>	<u>other</u>
n=	6	0	1	0	0

[No, not necessarily] E.g. in Beijing one is allowed to drive only every second day!

A71 Oil demand in electricity generation keeps high as diesel power plants are the least risky investment in many politically unstable societies.

	<u>Y</u>	<u>Y/N</u>	<u>N</u>	<u>Blank</u>	<u>other</u>
n=	6	0	0	1	0

A72 There is very high paying capacity in western countries. E.g. 3 €/l level is still affordable if your modern car runs with 4 l/100 km. (12 c/km fuel cost).

	<u>Y</u>	<u>Y/N</u>	<u>N</u>	<u>Blank</u>	<u>other</u>
n=	7	0	0	0	0

Yes, people pay for mobility.

A73 States need environmental taxes.

	<u>Y</u>	<u>Y/N</u>	<u>N</u>	<u>Blank</u>	<u>other</u>
n=	7	0	0	0	0

A74 Bio-component is made mandatory and that increases the cost level.

	<u>Y</u>	<u>Y/N</u>	<u>N</u>	<u>Blank</u>	<u>other</u>
n=	6	0	1	0	0

[No,] if oil 120-150 no additional cost.

A75 High price level serves the political target of curtailing the oil consumption.

	<u>Y</u>	<u>Y/N</u>	<u>N</u>	<u>Blank</u>	<u>other</u>
n=	7	0	0	0	0

Key arguments in favor of only moderate growth in fuel prices:

A76 Peak oil will not be encountered by 2020.

	<u>Y</u>	<u>Y/N</u>	<u>N</u>	<u>Blank</u>	<u>other</u>
n=	1	0	6	1	0

[No,] *unless new sources will not be found, peak oil is very close now.*

[No,] *So far it looks it was already*

[No, but] *Share of renewable and nuclear energy will increase [thus keeping the price development moderate]*

A77 It is not in oil producers interests to ruin the present healthy demand by very high price level. They will keep increasing the supply.

	<u>Y</u>	<u>Y/N</u>	<u>N</u>	<u>Blank</u>	<u>other</u>
n=	3	0	5	0	0

[No,] *I tend to believe that OPEC maximizes long term revenues by adjusting supply while non-OPEC follows [Sometimes this means curtailing the supply?]*

[No, supply can't be increased that easily as] *There is a limit in cheap oil fields.*

[No,] *They do not need increase, stable demad is better.*

A78 Macro-economic importance of transportation cost holds diesel down.

	<u>Y</u>	<u>Y/N</u>	<u>N</u>	<u>Blank</u>	<u>other</u>
n=	3	0	4	0	0

[No,] *In very few products the influence of diesel is more than 5%.*

A79 Fuel consumption of cars is decreasing rapidly.

	<u>Y</u>	<u>Y/N</u>	<u>N</u>	<u>Blank</u>	<u>other</u>
n=	8	0	0	0	0

Yes, but more cars will be in use in emerging markets.

A80 There is strong consumer resistance against increase in prices. Consumer opinion holds 2,2€/l level terrible so that it would radically impact consumption.

	<u>Y</u>	<u>Y/N</u>	<u>N</u>	<u>Blank</u>	<u>other</u>
n=	3	0	4	1	0

[No,] *Cost of personal transport doesn't have a large share in personal spending.*

[Blank,] *Who cares. Politicians like to have a problem which covers even bigger problems.*

A81 Alternative fuels and electricity will increase their share.

	<u>Y</u>	<u>Y/N</u>	<u>N</u>	<u>Blank</u>	<u>other</u>
n=	7	1	0	0	0

[Yes,] *ultra high development boom.*

[Y/N] *The costs are high and market share will stay moderate until 2020.*

[Yes, but only] *For rich people. Lauri Mäkipaja, Corenso: "Recycling is not for the poor".*

Yes, but over all consumption will increase globally.

Title	Impact of waste-to-energy on the demand and supply relationships of recycled fibre
Author(s)	Petri Ristola
Abstract	<p>Today, recycled fibre is globally the most important papermaking raw material in terms of volume. Its collection and use has tripled in absolute terms since 1990 and its market share of all fibres used in papermaking has increased by roughly 1 %-unit per year. Still, globally speaking, about a third of the volume of used paper that could potentially be used for recycling is just disposed of. Thus, recycled fibre can, and is expected to, further increase its market share of papermaking fibres.</p> <p>There is, however, increasing turmoil in the market for papermaking raw materials as a consequence of the political agenda aimed at mitigating global warming and decreasing the use of fossil fuels. This has already become evident in the European fuel wood market, and there is also growing interest in the efficient utilisation of the fuel component in solid wastes, including the discarded paper that currently remains outside recycling. Today in Europe, just about a third of the solid waste is recovered as energy, mostly at relatively low-efficiency waste incineration facilities.</p> <p>The paper industry has recently played an active role in these trends, too. Recycled-fibre-based paper mills in Europe have started to employ modern technology for the sole and co-combustion of refuse-derived fuels and process tailings. These units are dimensioned for the energy needs of the paper mills and have been found to be highly effective in cutting the energy bill for recycled-fibre-based papermaking. In continuance of this theme, proposals have been made concerning more advanced concepts that employ fibre separation techniques from different solid waste streams for further utilisation in the manufacturing of paper products, or, for instance, in ethanol conversion. This development underlines the strong technical synergies between recycled-fibre-based papermaking and modern waste-to-energy technologies. At the same time it poses serious questions concerning the expected further increase in the usage of recycled fibre in papermaking.</p> <p>This dissertation discusses the application of modern waste-to-energy technologies in the paper industry as a means of improving individual paper mills' competitive positions and financial performance. Their impact is found to be clearly significant and therefore the on-going investment activity can be expected to continue. As the use of various solid wastes for fuel potentially interferes with the targeted increase in paper recycling, there emerges a need to analyse the impacts of this development on the recycled fibre markets. This is achieved by developing a quantifiable model for analysing the composite market for various discarded-paper-containing waste flows and by conducting a Delphi study on the supply-demand behaviour of recycled fibre. The Delphi study utilised a panel of experts to i) gain support and feedback concerning the construction of the composite market model, ii) gain qualitative insight on the likely development scenarios for the recovered paper market, and iii) create a basis for preliminary quantification and testing of the model.</p> <p>By combining the results of the Delphi study and the composite market model, this study paints a picture of a future scenario for the composite RCF market in Europe in 2020. The main scenario is complemented by a selection of alternative views of the future that stem from the Delphi process. It becomes evident that the times of inexpensive recycled fibre for papermaking are past, and that the energy sector is also developing significant paying capabilities for recycled-fibre-containing waste flows.</p>
ISBN, ISSN	ISBN 978-951-38-7451-3 (soft back ed.) ISSN 2242-119X (soft back ed.) ISBN 978-951-38-7452-0 (URL: http://www.vtt.fi/publications/index.jsp) ISSN 2242-1203 (URL: http://www.vtt.fi/publications/index.jsp)
Date	June 2012
Language	English, Finnish abstract
Pages	190 p. + app. 130 p.
Keywords	Pulp and paper industry, recycled fibre, recovered paper, wastepaper, waste-to-energy, foresight study, Delphi, price theory, constructive research
Publisher	VTT Technical Research Centre of Finland P.O. Box 1000, FI-02044 VTT, Finland, Tel. 020 722 111

Nimeke	Jätteiden energiakäytön vaikutukset kiertokuidun kysyntä- ja tarjontasuhteisiin
Tekijä(t)	Petri Ristola
Tiivistelmä	<p>Kiertokuitu on nykyisin määrällisesti mitattuna maailmanlaajuisesti merkittävin paperinvalmistuksen raaka-aine. Sen keräily ja käyttö on tonneissa kolminkertaistunut vuodesta 1990 ja markkinaosuus kaikesta paperiteollisuuden käyttämästä kuidusta on kasvanut vuosittain noin yhdellä prosenttiyksiköllä. Maailmanlaajuisesti tarkasteltuna edelleen noin kolmannes käytöstä poistetusta paperista, joka teoriassa voitaisiin kierrättää, tulee hävitetyksi. Siten kiertokuitu voi, ja sen edelleen myös odotetaan kasvattavan markkinaosuuttaan paperinvalmistuksen kuitu-raaka-aineiden joukossa.</p> <p>Paperinvalmistuksessa käytettyjen raaka-aineiden markkinoilla esiintyy kasvavaa kuuhuntaa, joka on seurausta poliittisista päätöksistä, jotka tähtäävät ilmastonmuutoksen hillitsemiseen ja riippuvuutemme vähentämiseen fossiilisista polttoaineesta. Tämän kehityksen seuraukset ovat jo nähtävissä Euroopan energiapuumarkkinoilla, ja myös kiinteisiin jätteisiin ja erityisesti niiden palavan jakeen tehokkaaseen hyödyntämiseen kohdistuu kasvavaa kiinnostusta. Tämä jae pitää sisällään myös kierrätyksen ulkopuolella olevan jätepaperin. Nykyisin Euroopassa, ainoastaan noin kolmannes kiinteistä jätteistä hyödynnetään energiana, siitäkin suurin osa melko heikon hyötysuhteen jätteenpolttolaitoksissa.</p> <p>Myc paperiteollisuus on viime aikoina ollut aktiivinen tässä kehityksessä. Kiertokuituun perustuvat paperitehtaat ovat ryhtyneet ottamaan käyttöön modernia voimalaitosteknologiaa kierrätyspolttoaineiden ja tuotantojätteiden yhteispoltossa. Nämä yksiköt on tyypillisesti mitoitettu vastaamaan paperitehtaan energiatarpeeseen, ja ne pystyvät tehokkaasti pienentämään kiertokuitupohjaisten paperitehtaiden energiakustannuksia. Tämän kehityksen jatkokehittelminä on ehdotettu myös edistyskellisempiä konsepteja, jotka hyödyntävät kuidun erotustekniikoita erilaisista jätevirroista, jolloin jätevirtojen kuituusuus voidaan hyödyntää raaka-aineena paperin tai esimerkiksi etanolin valmistuksessa. Tämä kehityssuunta alleviivaa nykyaikaisen jätteiden energiakäytön ja paperinvalmistuksen synergieitoja, mutta samanaikaisesti herättää kysymyksen, voiko kiertokuidun markkinaosuus jatkaa odotettua kasvuaan paperinvalmistuksessa.</p> <p>Väitöskirja tarkastelee nykyaikaisten jätteiden energiakäyttökäytännöiden käyttöönottoa paperitehtailta keinona parantaa niiden kilpailuasemaa ja taloudellista kannattavuutta. Vaikutuksen todetaan olevan merkittävä, ja siksi jo meneillään olevan kehityksen voidaan olettaa jatkuvan. Koska erinäisten kiinteiden jätevirtojen hyödyntäminen polttoaineena saattaa häiritä tavoitteita lisätä paperin kierrätystä, syntyy tarve analysoida tämän kehityksen vaikutuksia kiertokuitumarkkinaan. Tämä toteutetaan kehittämällä kvantifioitavissa oleva komposiittimalli, joka yhdistää paitsi keräyspaperin myös muut jätepaperia sisältävät jätevirrat yhteen markkinamalliin. Kiertokuidun kysyntä- ja tarjontakäyttäytymisen ymmärtämiseksi tehtiin Delfoi-tutkimus, jossa asiantuntijapaneelin avulla saatiin i) tarvittava tuki ja asiantuntijapalautte koskien mallin rakentamista ii) kvalitatiivinen näkemys kiertokuitumarkkinan todennäköisistä kehitysskenaarioista ja iii) perusta mallin alustavalle kvantifioinnille ja testaamiselle.</p> <p>Yhdistämällä Delfoi-tutkimuksen tulokset ja markkinan komposiittimalli tämä tutkimus maalaa vision kiertokuidun komposiittimarkkinan tilasta Euroopassa vuonna 2020. Pääskenaariota täydennetään joukolla Delfoi-tutkimuksesta johdettavia vaihtoehtoisia skenaarioita. On ilmeistä, että edullisen kiertokuidun aika on ohi ja että myös energiasektorille syntyy merkittävää maksukykyä jätevirroista, jotka sisältävät kiertokuitua.</p>
ISBN, ISSN	ISBN 978-951-38-7451-3 (nid.) ISSN 2242-119X (nid.) ISBN 978-951-38-7452-0 (URL: http://www.vtt.fi/publications/index.jsp) ISSN 2242-1203 (URL: http://www.vtt.fi/publications/index.jsp)
Julkaisu aika	Kesäkuu 2012
Kieli	Englanti, suomenkielinen tiivistelmä
Sivumäärä	190 s. + liitt. 130 s.
Avainsanat	Pulp and paper industry, recycled fibre, recovered paper, wastepaper, waste-to-energy, foresight study, Delphi, price theory, constructive research
Julkaisija	VTT PL 1000, 02044 VTT, Puh. 020 722 111

VTT Technical Research Centre of Finland is a globally networked multitechnological contract research organization. VTT provides high-end technology solutions, research and innovation services. We enhance our customers' competitiveness, thereby creating prerequisites for society's sustainable development, employment, and wellbeing.

Turnover: EUR 300 million

Personnel: 3,200

VTT publications

VTT employees publish their research results in Finnish and foreign scientific journals, trade periodicals and publication series, in books, in conference papers, in patents and in VTT's own publication series. The VTT publication series are VTT Visions, VTT Science, VTT Technology and VTT Research Highlights. About 100 high-quality scientific and professional publications are released in these series each year. All the publications are released in electronic format and most of them also in print.

VTT Visions

This series contains future visions and foresights on technological, societal and business topics that VTT considers important. It is aimed primarily at decision-makers and experts in companies and in public administration.

VTT Science

This series showcases VTT's scientific expertise and features doctoral dissertations and other peer-reviewed publications. It is aimed primarily at researchers and the scientific community.

VTT Technology

This series features the outcomes of public research projects, technology and market reviews, literature reviews, manuals and papers from conferences organised by VTT. It is aimed at professionals, developers and practical users.

VTT Research Highlights

This series presents summaries of recent research results, solutions and impacts in selected VTT research areas. Its target group consists of customers, decision-makers and collaborators.

Impact of waste-to-energy on the demand and supply relationships of recycled fibre

This dissertation presents a new theoretical model for examining the supply and demand relationships of recycled fibre-containing material flows, including recovered paper and recovered fuels. In the development and testing of the new construct it employs a Delphi panel, a special panel of experts that is challenged to examine and discuss the likely developments of the supply-demand behaviour of recycled fibre.

The outputs of the research include practical conclusions concerning foreseeable developments in the market, as well as the identification of strategic opportunities for the paper industry in utilising recycled fibre. The era of inexpensive recycled fibre is past in Europe. The energy recovery of wastes will continue to develop and generate alternative uses for paper-containing waste flows. The paper industry has a few technical strengths in this context that could possibly be utilised for the creation of inimitable, largely structural competitive advantage. This could be realised by managing suitable waste flows and using them a) to secure the cheapest raw material base for paper making, b) to serve the industry's energy needs, and c) to create new business opportunities from waste-based products.

This research is cross-disciplinary and relates to the fields of industrial engineering and management, economics and the scientific study of the future.

ISBN 978-951-38-7451-3 (soft back ed.)

ISBN 978-951-38-7452-0 (URL: <http://www.vtt.fi/publications/index.jsp>)

ISSN 2242-119X (soft back ed.)

ISSN 2242-1203 (URL: <http://www.vtt.fi/publications/index.jsp>)

