

0110
1001
10110
0101

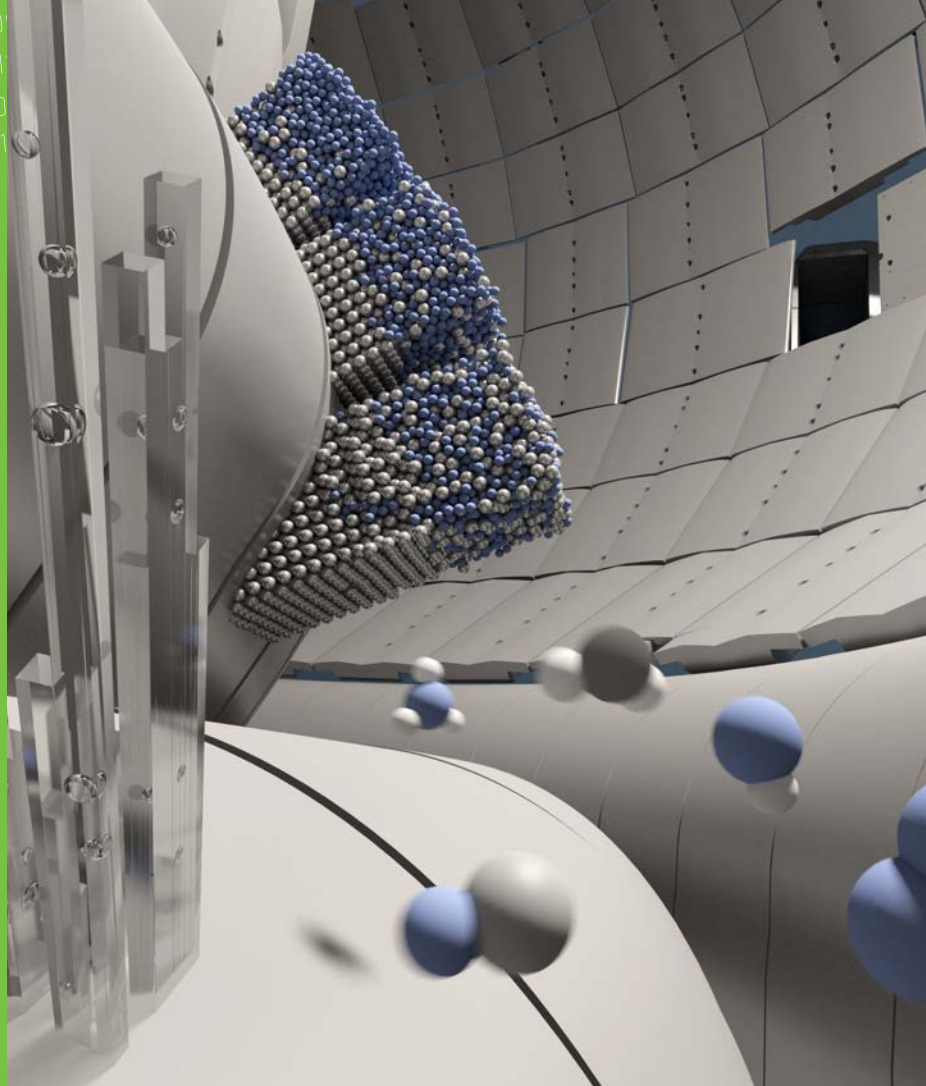

Fusion Yearbook

Association Euratom-Tekes
Annual Report 2013



Fusion Yearbook

Association Euratom-Tekes
Annual Report 2013

Markus Airila & Antti Hakola (eds.)

This work was supported by EURATOM and carried out within the framework of the European Fusion Development Agreement. The views and opinions expressed herein do not necessarily reflect those of the European Commission.



ISBN 978-951-38-8121-4 (Soft back ed.)
ISBN 978-951-38-8122-1 (URL: <http://www.vtt.fi/publications/index.jsp>)

VTT Science 54

ISSN-L 2242-119X
ISSN 2242-119X (Print)
ISSN 2242-1203 (Online)

Copyright © VTT 2014

JULKAISIJA – UTGIVARE – PUBLISHER

VTT
PL 1000 (Tekniikantie 4 A, Espoo)
02044 VTT
Puh. 020 722 111, faksi 020 722 7001

VTT
PB 1000 (Teknikvägen 4 A, Esbo)
FI-02044 VTT
Tfn. +358 20 722 111, telefax +358 20 722 7001

VTT Technical Research Centre of Finland
P.O. Box 1000 (Tekniikantie 4 A, Espoo)
FI-02044 VTT, Finland
Tel. +358 20 722 111, fax +358 20 722 7001

Cover picture: Jyrki Hokkanen, CSC (data: Ane Lasa). Artistic view on various interaction phenomena between plasma and beryllium/tungsten plasma-facing materials on a fusion reactor divertor.

Kopijyvä Oy, Kuopio 2014

Fusion Yearbook

Association Euratom-Tekes

Annual Report 2013

Fuusio-vuosikirja. Euratom-Tekes-assosiaation vuosikertomus 2013.

Markus Airila & Antti Hakola (eds.). Espoo 2014. VTT Science 54. 162 p. + app. 13 p.

Abstract

This Annual Report summarises the fusion research activities of the Finnish and Estonian Research Units of the Association Euratom-Tekes in 2013. The emphasis of the work coordinated by EFDA was in ITER Physics, PPPT and the ITM Task Force. Other EFDA activities in 2013 were carried out within Goal Oriented Training and EFDA Fellowship. In addition, a significant fraction of Tekes activities was directed to F4E grants and ITER contracts.

Fusion physics work is carried out at VTT, Aalto University (AU), University of Helsinki (UH) and University of Tartu (UT). The main activities are plasma experiments in collaboration with tokamak laboratories, modelling and code development, and diagnostics related to the main European fusion facilities JET and AUG. In particular, Association Euratom-Tekes focused on (i) Heat and particle transport and fast particle studies, (ii) Plasma-wall interactions and material transport in the scrape-off layer, and (iii) Development of simulation codes and their integration into the ITM environment.

The Association participated in the EFDA JET Workprogramme 2013, including C31 experiments with the ITER-like wall, edge and core modelling, diagnostics development and code integration. Three physicists were seconded to the JET operating team and one to EFDA CSU. The Association participated also in the 2013 experimental programme of ASDEX Upgrade at IPP and the analysis of DIII-D and C-Mod data.

Technology work is carried out at VTT, AU and Tampere University of Technology (TUT) in close collaboration with Finnish industry. Industrial participation is coordinated by Tekes. The technology research and development includes the DTP2 facility at VTT Tampere, materials and joining techniques, vessel/in-vessel components, magnetic diagnostics for ITER by micromechanical magnetometers, upgrading of the JET NPA diagnostics, Power Plant Physics and Technology (PPPT) activities, plasma facing materials issues, erosion/re-deposition and material transport studies and development of coating techniques.

Association Euratom-Tekes is involved in Goal-Oriented Training in Remote Handling project, coordinated by Tampere University of Technology. In July 2013, the 40th EPS Plasma Physics Conference, organized by AU, gathered over 600 participants in Espoo.

Keywords

nuclear fusion, fusion energy, fusion research, fusion physics, fusion technology, fusion reactors, fusion reactor materials, ITER remote handling, Euratom

Fuusio-vuosikirja

Euratom-Tekes-assosiaation vuosikertomus 2013

Fusion Yearbook. Association Euratom-Tekes Annual Report 2013.

Markus Airila & Antti Hakola (toim.). Espoo 2014. VTT Science 54. 162 s. + liitt. 13 s.

Tiivistelmä

Tähän vuosikirjaan on koottu Suomen ja Viron fuusiotutkimusyksiköiden vuoden 2013 tulokset ja saavutukset. Työ on tehty Euratom-Tekes-assosiaation puitteissa. EFDAn koordinoima työ keskittyi ITERin fysiikkaan, DEMOn fysiikkaan ja tekniikkaan (power plant physics and technology, PPPT) ja integroituun mallinnukseen (integrated tokamak modelling, ITM). EFDA-työtä tehtiin vuonna 2013 uusien asiantuntijoiden koulutuksessa (goal oriented training in remote handling, GOTRH, ja EFDA Fellowship). Tampereen teknillinen yliopisto oli koordinoitavastuussa GOTRH-projektissa. F4E-organisaation myöntämällä rahoituksella ja ITER-sopimuksilla on ohjelmassa merkittävä osuus.

Fysiikan tutkimusta tehdään VTT:llä, Aalto-yliopistossa, Helsingin yliopistossa sekä Tarton yliopistossa, ja se keskittyy plasmakokeisiin yhteistyössä tokamak-laboratorioiden kanssa ja niiden mallinnukseen. Assosiaation erityisiä painopiste-alueita ovat (i) Lämmön ja hiukkasten kuljetus ja nopeiden hiukkasten fysiikka, (ii) Plasma–seinämä-vuorovaikutukset ja materiaalien kulkeutuminen kuorintakerroksessa sekä (iii) Simulointiohjelmistojen kehitys ja integrointi ITM-ympäristöön.

Vuonna 2013 Euratom-Tekes-assosiaatio osallistui EFDA-JETin koekampanjaan C31, reuna- ja sydänplasman mallinnukseen, diagnostiikan kehitykseen ja simulointiohjelmien integrointiin. Kolme fyysikkoa toimi JETin käyttöorganisaatiossa ja yksi EFDAn tukioorganisaatiossa (close support unit, CSU). Lisäksi assosiaatio osallistui ASDEX Upgrade -tokamakin vuoden 2013 koeohjelmaan sekä DIII-D- ja C-Mod-tokamakien tulosten analysointiin.

Teknologiatyötä tekevät VTT, Aalto-yliopisto ja LTY tiiviissä yhteistyössä suomalaisen teollisuuden kanssa. Yritysten osallistumista koordinoi Tekes. Kehitettäviiin teknologioihin kuuluvat DTP2-laitteisto VTT:llä Tampereella, materiaalit ja niiden liitostekniikat, tyhjiökammioon liittyvät komponentit, MEMS-pohjaisten diagnostiikkojen kehitys ITERin magneettikenttien mittausta varten, JETin NPA-diagnostiikan päivitys, osallistuminen PPPT-tutkimukseen, ensiseinämän materiaalit, eroosion, deposition ja materiaalien kulkeutumisen tutkimus sekä pinnoitteiden kehittäminen.

Heinäkuussa 2013 Aalto-yliopisto järjesti Dipolissa Espoossa kiittävää palautetta saaneen EPS:n plasmafysiikan konferenssin, johon osallistui yli 600 fyysikkoa.

Avainsanat nuclear fusion, fusion energy, fusion research, fusion physics, fusion technology, fusion reactors, fusion reactor materials, ITER remote handling, Euratom

Foreword



Although 2013 was my first full year as the head of the research unit, it was the last year of fusion research under Association Euratom-Tekes in Finland. The preparation for this change from the association structure towards a consortium-based structure included a large number of meetings, planning and discussions with the Commission and key people within the European fusion research community. As a result of the hectic and busy year, the European fusion community has now a document called “Workplan for the implementation of the Fusion Roadmap in 2014–2018”. This document has the goal of implementing the activities of the Roadmap during Horizon 2020, and thus gives a strong guideline also where to direct the Finnish fusion activities in years to come.

In 2013, the emphasis of the Association Euratom-Tekes programme was very strongly in the EFDA work programme and in the exploitation of the JET tokamak. Plasma–wall interaction and modelling of plasma, transport experiments and fast ion physics studies were the main topics, and the work of the Association was carried out under ITER Physics and PPPT (Power Plant Physics and Technology) departments. The plasma–material studies also link the Estonian research unit very well into the Finnish research unit. The NPA upgrade systems were operated and an upgrade with new silicon detectors proposed. The F4E Grant for magnetic diagnostics based on micro-mechanical sensors was continued and a new F4E grant solving the magnetization of ferromagnetic components in ITER initiated. Post-mortem analysis of the JET first wall and divertor tiles and related plasma-wall studies continued under JET Technology Task Force.

One Tekes scientist acted as deputy task force leader (Fusion Technology) for JET. In addition, Tekes provided three JOC secondees, one CSU secondie and a member to HLST (high level support team for high performance computing). Collaboration with the AUG team at IPP Garching continued in 2013 and has been very important and productive activity for several years. International activities included tokamak experiments and tokamak edge modelling in the US on DIII-D tokamak under IEA Implementing Agreement and two official members in two different ITPA groups.

The F4E Grant 401 continues a long series of tests and development work of ITER divertor remote maintenance. The maintenance devices, processes and the reactor components have been developed. A lot of valuable development work has been done which helps to find optimal design of critical components. Remote handling and methods and tools needed for reliability and availability design and assurance for DEMO have also been actively studied under the EFDA department PPPT by the same group of researchers.

One of the major fusion research related efforts in Finland was the organisation of the EPS Plasma Physics Conference 2013. The conference gathered over 600 plasma physicists to sunny Espoo on the first week of July. The Local Organizing Committee was chaired by T. Kurki-Suonio and the LOC members represented AU, VTT, UH and Tavicon Ltd.

The Finnish expertise is very much required within the European Fusion programme, and therefore the European resources to Finnish fusion research will increase in 2014. I am very confident that the Finnish fusion research will give a valuable contribution to the Euratom Fusion Programme via the EUROFUSION Consortium, F4E and ITER also during Horizon 2020. Finally, I would like to express my most sincere thanks to Tekes and the scientists and engineers of the Finnish and Estonian Research Units for their excellent and dedicated work in fusion physics and technology R&D in 2013.



Tuomas Tala
Head of Research Unit,
Association Euratom-Tekes

Acknowledgements

A large part of the activities of Association Euratom-Tekes involves massive number-crunching, and we want to acknowledge the computation service providers who make our work possible.

The Elmfire project “Full-f gyrokinetic simulation of edge pedestal in Textor” was granted 30 million core hours on GCS HPC system SuperMUC 4th PRACE call which was mostly used during 2013. ASCOT group has used 0.61 MCPU-h at HPC-FF 6/2012–6/2013 and 1.6 MCPU-h at Iferc Helios 2nd cycle 11/2012–11/2013. Also Elmfire was ported and tested for these computers. During 2013 the fusion group has used about 1.6 MCPU-h for simulations at CSC – IT Center for Science Ltd, most of which was used for Elmfire simulations. Many thanks also to Aalto University Science-IT project for High Performance Computing (HPC) services, and Aalto University Department of Applied Physics for High Throughput Computing (HTC) Services.

Contents

Abstract	3
Tiivistelmä	4
Foreword.....	5
Acknowledgements	7
List of acronyms and names	13
Executive Summary.....	17
1. Overview of 2013 Activities.....	21
2. Fusion Programme Organisation.....	23
2.1 Programme Objectives	23
2.2 Association Euratom-Tekes	23
2.3 Research Unit	24
2.4 Association Steering Committee (ASC)	24
2.5 National Steering Committee.....	25
2.6 Finnish Members in the European Fusion Committees.....	26
2.6.1 Euratom Science and Technology Committee (STC).....	26
2.6.2 Consultative Committee for the Euratom Specific Research and Training Programme in the Field of Nuclear Energy – Fusion (CCE-FU).....	26
2.6.3 EFDA Steering Committee	26
2.6.4 Science and Technology Advisory Committee (STAC)	26
2.6.5 Governing Board for the Joint European Undertaking for ITER and the Development of Fusion Energy, “Fusion for Energy” (F4E GB).....	26
2.6.6 Executive Committee for the Joint European Undertaking for ITER and the Development of Fusion Energy, “Fusion for Energy” (F4E ExCo).....	26
2.6.7 Other international duties and Finnish representatives in the following fusion committees and expert groups in 2013.....	27

2.7	Public Information Activities	28
2.8	Funding and Research Volume 2013.....	30
2.9	40th EPS Conference on Plasma Physics	30
3.	EFDA Fusion Physics and Materials Research	33
3.1	Energy and Particle Confinement and Transport.....	34
3.1.1	Momentum transport studies on AUG and JET	34
3.1.2	Calculating rotation drive due to fast ions.....	36
3.1.3	Thermal ion ripple torque and ion orbit losses in setting up boundary rotation in Tore Supra and AUG	37
3.1.4	European multi-tokamak intrinsic rotation database.....	38
3.1.5	Full-f gyrokinetic simulation of edge pedestal in Textor.....	39
3.1.6	JET and JT-60U current profile modelling with identity plasma experiments: the effect of equilibrium in JET	40
3.1.7	Particle pinch studies on JET	41
3.1.8	Effect of TBM on plasma rotation.....	42
3.2	Power and Particle Exhaust, Plasma-Wall Interactions.....	44
3.2.1	Material transport and erosion/deposition in JET.....	44
3.2.2	Material transport and erosion/deposition in AUG.....	50
3.2.3	Collaboration with IPP Garching and FZJ on fluid edge modelling: code updates, comparison to experimental data from AUG and JET	55
3.2.4	Collaboration with General Atomics/DIII-D/ Lawrence Livermore on fluid edge code simulations with and without Monte Carlo neutrals for pedestal fuelling.....	57
3.2.5	Erosion and fuel retention properties of mixed beryllium- containing materials	57
3.2.6	Exposing W samples to Magnum-PSI and Pilot-PSI plasmas ..	60
3.2.7	Simulating W fuzz formation using MD	62
3.2.8	Modelling monovacancy diffusion and fuel retention in W	63
3.2.9	Arc-discharge cleaning of plasma-facing components	65
3.3	Physics of plasma heating and current drive.....	66
3.3.1	Development and tests of ICRH heating module in ASCOT+RFOF	66
3.4	Energetic Particle Physics.....	67
3.4.1	Modelling fast ion redistribution and wall loads in the presence of MHD activity	67
3.4.2	Simulating escaping fast ion loss diagnostics in ASDEX Upgrade	68
3.5	Theory and Modelling for ITER and DEMO.....	69
3.5.1	SimITER 2010–2013.....	69
3.5.2	ITER 3D wall from CAD data.....	70
3.5.3	Reconstructing 3D plasma equilibrium with ELMER	71
3.5.4	Modelling of material mixing for extrapolation to ITER conditions.....	71

3.5.5	Theoretical work on Coulomb collision models	72
3.6	Code Development and Integration	72
3.6.1	Shielding factor model for current drive studies with ASCOT code	72
3.6.2	Fusion product source for ASCOT	73
3.6.3	Checkpoint system for ASCOT	74
3.6.4	Gyrokinetic global SOL/edge code development	74
3.6.5	Benchmarking of SOL turbulence code.....	75
3.6.6	First principle based core/edge transport simulations using HPC resources	75
3.6.7	Code validation and performance scaling.....	76
3.6.8	High performance computing / OpenMP and GPGPU in ASCOT.....	76
3.6.9	Development of Kepler workflows for integrated modelling	77
3.6.10	ASCOT-BBNBI in EFDA-ITM framework.....	78
3.7	Plasma Diagnostics	78
3.7.1	Operator support for JET neutron diagnostics during maintenance.....	78
3.7.2	Operator support for JET NPA(s) during campaigns.....	79
3.7.3	Plan for low energy NPA maintenance and upgrade.....	79
3.8	Power Plant Physics & Technology	80
3.8.1	Power plant power exhaust studies	80
3.8.2	Modelling of radiation effects in FeCr, tungsten and tungsten alloys.....	81
3.8.3	Remote handling studies for DEMO.....	84
3.8.4	Continuing the work on RAMI methods & tools.....	88
4.	CSU and JOC Secondments, TFL Activities, Staff Mobility and Training	89
4.1	EFDA CSU Secondment.....	89
4.2	CCFE JOC Secondments	90
4.2.1	JET Plasma Boundary Group.....	90
4.2.2	JET Data and Codes Management Group	92
4.2.3	JET Neutron Group.....	93
4.3	Task Force Leader Activities	93
4.4	Staff Mobility Visits and Reports.....	94
4.4.1	Framework agreement between Associations Tekes and IPP: Power and particle exhaust	94
4.4.2	Erosion and retention investigations of ASDEX Upgrade marker tiles and probes (1).....	95
4.4.3	SOLPS modelling of ASDEX Upgrade low-density discharges with and without impurity seeding.....	97
4.4.4	Momentum and particle transport, joint ITPA Experiment TC-15 and TC-17 between JET, DIII-D, NSTX, C-Mod and ASDEX Upgrade.....	99

4.4.5	JINTRAC simulation project on fuelled and seeded JET baseline ELMy H-mode plasmas	100
4.4.6	LIBS measurements of Be test samples	102
4.4.7	Participation in the project meeting of JET TF-FT Task JWI3-FT-3.80.....	103
4.4.8	Neutral beam current drive modelling (1)	104
4.4.9	Studying irradiation defects in tungsten.....	106
4.4.10	Numerical (ASCOT) study of activation probe experiments....	107
4.4.11	Studying runaway electron dynamics in tokamaks.....	108
4.4.12	Material migration in JET C wall and ILW plasmas	109
4.4.13	LIBS measurements of JET samples (1).....	110
4.4.14	Neutral beam current drive modelling (2)	111
4.4.15	In situ LIBS measurements and study of tungsten coatings erosion at Magnum-PSI (1).....	112
4.4.16	Verification and validation of RH system requirement using Digital Mock-ups (1).....	114
4.4.17	Effect of impurities on the plasma flow.....	116
4.4.18	SOLPS modelling of the inner divertor of ASDEX Upgrade....	117
4.4.19	Power exhaust studies with JET-ILW for model validation (1).....	118
4.4.20	Gyrokinetic full f multiscale transport studies of Ohmic Textor discharges	119
4.4.21	In situ LIBS measurements and study of tungsten coatings erosion at Magnum-PSI (2).....	120
4.4.22	Power exhaust studies with JET-ILW for model validation (2).....	122
4.4.23	Remote handling system analysis	123
4.4.24	RAMI requirements for RH equipment	124
4.4.25	Erosion and retention investigations of ASDEX Upgrade marker tiles and probes (2).....	126
4.4.26	Validation of SOLPS simulation results against ASDEX Upgrade diagnostic data	127
4.4.27	Verification and validation of RH system requirement using Digital Mock-ups (2).....	129
4.4.28	ASCOT-HAGIS benchmark	130
4.4.29	Investigation of properties of Jet ITER-like wall (ILW) samples using laser-induced breakdown spectroscopy (LIBS)	131
4.5	Euratom and EFDA Fusion Training Scheme.....	132
4.5.1	EFDA goal oriented training in remote handling – GOTRH	132
5.	Fusion for Energy and ITER Activities.....	134
5.1	ITER Divertor Test Platform (DTP2)	134
5.1.1	RH-trials on the exchange of the second divertor cassette	134
5.1.2	RH-trials on the exchange of the central divertor cassette	135
5.1.3	Refurbishment of the DTP2 facility.....	136

5.2	Upgrade of the Divertor Cassette Mock-Up and verification of the Locking System – Part 2.....	136
5.3	R&D/design of sensors for the ITER magnetics diagnostic: Design of the outer-vessel steady-state discrete sensor system	138
5.4	Calculating the magnetization of ferromagnetic ITER components....	139
6.	Other Activities	141
6.1	Conferences, workshops and meetings	141
6.2	Visits.....	145
6.3	Visitors.....	147
	Publications 2013	149
6.4	Fusion Physics and Plasma Engineering	149
6.4.1	Publications in scientific journals	149
6.4.2	Conference articles – physics and plasma engineering	154
6.5	Fusion technology	156
6.5.1	Publications in scientific journals	156
6.5.2	Conference articles – fusion technology.....	159
6.5.3	Research reports – fusion technology.....	161
6.6	Doctoral and graduate theses	161

Appendices

- Appendix A: Introduction to Fusion Energy
- Appendix B: Institutes and Companies

List of acronyms and names

AFSI	AFSI Fusion Source Integrator
ASC	Association Steering Committee
ASCOT	Accelerated Simulation of Charged Particle Orbits in Tori (particle tracing code)
AU	Aalto University, Espoo/Helsinki, Finland
AUG	ASDEX Upgrade (tokamak facility)
BBNBI	Beamlet-based neutral beam injection (simulation code)
CAD	Computer-aided design
CCEE	Central cassette end-effector
CCFE	Culham Centre for Fusion Energy
CCOR	Central cassette outer rail
CD	Current drive
CEA	Commissariat à l'Énergie Atomique et aux Énergies Alternatives (French Association)
CIEMAT	Centro de Investigaciones Energéticas, Medioambientales y Tecnológicas (Spanish Association)
CLS	Cassette locking system
CMM	Cassette multifunctional mover
COTS	Commercial off-the-shelf (components)
CPO	Consistent Physical Object (ITM datastructure)
CRESTA	Collaborative research into exascale systemware, tools & applications
CRPP	Centre de Recherches en Physique des Plasmas, Lausanne
CSC	(Finnish) IT Center for Science
CSU	Close Support Unit (of EFDA; Garching, Culham)
DIII-D	Tokamak facility at General Atomics, San Diego
DIFFER	Dutch Institute for Fundamental Energy Research
DIVIMP	Divertor impurity (impurity transport simulation code)

DFT	Density-functional theory
DTP2	Divertor test platform phase 2 (test facility in Tampere)
EC	European Commission
ECRH	Electron cyclotron resonance heating
EDGE2D	Fluid plasma simulation code
EFDA	European Fusion Development Agreement
EH&CD UL	Electron heating and current drive upper launcher (for ITER)
EIRENE	Neutral particle simulation code
ELM	Edge localised mode (plasma instability)
ELMFIRE	Gyrokinetic particle-in-cell simulation code
ENEA	Ente per le Nuove tecnologie, l'Energia e l'Ambiente (Italian Association)
EPS	European Physical Society
ERM-KMS	Ecole Royale Militaire / Koninklijke Militaire School (Belgian Association)
ERO	Monte Carlo impurity transport simulation code
ETS	European transport solver (simulation code)
FI	Ferritic insert
FILD	Fast ion loss diagnostic
FZJ	Forschungszentrum Jülich
GA	General Atomics
GAM	Geodesic acoustic mode (plasma instability)
GOTRH	Goal-oriented training for remote handling
HAGIS	Simulation code for plasma waves and fast particles
HCF	Hot cell facility
HFS	High-field (inner) side of tokamak
HPC	High-performance computing
HPC-FF	High-performance computer for fusion
ICRH	Ion cyclotron resonance heating
IFP	Istituto di Fisica del Plasma, Milan
ILW	ITER-like wall
IPP	Institut für Plasmaphysik, Garching/Greifswald
IST	Instituto Superior Técnico, Lisbon
ITB	Internal transport barrier
ITG	Ion temperature gradient
ITM	Integrated Tokamak Modelling
ITPA	International Tokamak Physics Activity
JET	Joint European Torus (tokamak facility)

JETTO	Transport code
JINTRAC	JET integrated suite of transport codes
JOC	JET Operating Contract
JT-60U	Japan Torus 60 Upgrade (tokamak facility)
KMC	Kinetic Monte Carlo (material simulation method)
KTH	Kungliga Tekniska Högskolan (Royal Institute of Technology), Stockholm
LEI	Lietuvos Energetikos Institutas (Lithuanian Association)
LIBS	Laser induced breakdown spectroscopy
LFS	Low-field (outer) side of tokamak
LLNL	Lawrence Livermore National Laboratory
LOC	Local organising committee
Magnum-PSI	Linear plasma generator at DIFFER (the Netherlands)
Mascot	Dextrous two arm servo-manipulator at JET
MD	Molecular dynamics (simulation method)
MDS+	Set of software tools for data acquisition and storage
MEdC	Ministerul Educației și Cercetării (Romanian Association)
MEMS	Micro-electro-mechanical system
MHD	Magnetohydrodynamics
NBCD	Neutral beam current drive
NBI	Neutral beam injection
NPA	Neutral particle analyser
NRA	Nuclear reaction analysis
NTM	Neoclassical tearing mode (plasma instability)
ORNL	Oak Ridge National Laboratory
OSD	Operational sequence definition
OSM	Onion-skin model (for plasma simulation)
PARCAS	Molecular dynamics code
PDF	Plant definition form
PET	Plasma edge theory (workshop)
Pilot-PSI	Linear plasma generator at DIFFER, the Netherlands
PISCES-B	Linear plasma generator at UCSD, San Diego, US
PPPL	Princeton Plasma Physics Laboratory
PRACE	Partnership for Advanced Computing in Europe
RAMI	Reliability, Availability, Maintainability, Inspectability
RBS	Rutherford backscattering spectroscopy
RH	Remote handling

SEM	Scanning electron microscope
SimITER	Research consortium of AU, UH, ÅA, VTT and CSC
SIMS	Secondary Ion Mass Spectroscopy
SOL	Scrape-off layer
SOLPS	Scrape-off Layer Plasma Simulation (fluid plasma simulation code)
TAE	Toroidal Alfvén eigenmode (plasma instability)
TBM	Tritium breeding module, Test blanket module (in the case of ITER)
TDF	Task definition form
TEM	Trapped electron mode (plasma instability)
TEXTOR	Tokamak experiment for technology-oriented research (Jülich)
TFL	Task-force leader
UCSD	University of California, San Diego
UEDGE	Fluid plasma simulation code
UH	University of Helsinki
UL	Upper launcher (for ITER heating systems)
UPL	Upper port launcher
UT	University of Tartu
VR	Virtual reality
VTT	Technical Research Centre of Finland
WALLDYN	2D impurity transport simulation code
WGA	Waveguide assembly
XRD	X-ray diffraction
ÅA	Åbo Akademi University, Turku, Finland

Executive Summary

Overview

Focus areas of research were collaborative plasma experiments in tokamaks (in particular JET and AUG), modelling supported by code development, and participation in diagnostics development. The main emphasis of the EFDA work was in ITER Physics, PPPT and the ITM Task Force. F4E grants and ITER contracts are included in this report as supplementary information. A particular highlight in 2013 was the EPS Plasma Physics Conference held in Espoo. The scientific merits of the Association were notably recognized by the EPS plenary talk of A. Hakola.

Confinement and transport

A number of H-mode discharges with D gas puff modulation were executed at JET to study particle sources and transport in the plasma edge region. Clear perturbation in electron density was seen throughout the radius, the effect being the strongest when using the outer midplane inlet possibly due to the narrow SOL. The influence of plasma geometry on the bootstrap current was studied using JETTO simulations. The inverse aspect ratio had the largest effect on the bootstrap current: a threefold increase when changing the aspect ratio from 0.2 to 0.4.

On AUG the effect of the q-profile and ECRH on intrinsic rotation were studied. Our measurements show that co-current intrinsic torque increases with plasma current while adding 3 MW of ECRH reduced the rotation by 30–50%. Changes of transport and generation of torque in this process depend on the vicinity of the ITG/TEM threshold.

The DIII-D mock-up TBM experiments with modulated TBM perturbation amplitude were analysed. The observed propagation of the induced rotation perturbation was best reproduced with an edge localised counter-current torque source. The magnitude of the torque was estimated to -2.5 Nm for a perturbation that is about 3 times larger than those expected in ITER.

A series of ELMFIRE simulations of plasma turbulence for TEXTOR were carried to study parametric dependencies of GAMs. Correlation analysis shows that the radial propagation speed is mainly affected by temperature.

Energetic particle physics

ASCOT was applied to study the effects of NTMs on energetic ion confinement in the 15 MA H-mode scenario of ITER. An amplitude scan over the NTM magnitude revealed that the fusion alpha particle heat load to the wall structures would stay safely within the design limits. Alfvén eigenmodes in the 9 MA hybrid scenario were, however, observed to cause significant redistribution. ASCOT has also been used in modelling the fusion product activation probe experiment in AUG. The probe orientation was found to be less than optimal, as most of the fusion products were filtered by the graphite cap of the probe.

Power and particle exhaust, plasma-wall interactions

A significant part of the work was devoted to the first *post mortem* analysis of the JET ILW divertor tiles. Migration of material towards the inner divertor had decreased and the fuel retention reduced by a factor of 10 compared to the carbon-wall era of JET. The thickest layers (up to 15 μm) were observed on the apron region of Tile 1, mainly containing Be and hardly any C or D. In the modelling front, fluid code simulations explained (i) the reduced ion current around the outer strike point during transition from high-recycling to partially detached divertor within 50%, and (ii) experimentally observed radiation peak around the outer X-point in N_2 - and Ne-seeded H-mode plasmas. Finally, migration of ^{13}C impurities, originating from the outer divertor, was modelled using EDGE2D/EIRENE, ERO, and DIVIMP. Transport via the main chamber to the inner divertor played an important role and re-erosion further modified the primary deposition patterns.

The first-wall studies in AUG were continued by determining campaign-integrated erosion/deposition profiles at the top and inner wall structures of the vessel. Both regions were net deposition zones for W. At the outer midplane, the exposure of a marker probe to low-power H-mode plasmas indicated strong net erosion even for W. Modelling work focused on injected ^{13}C and ^{15}N impurities from the outer midplane. Complementary use of SOLPS, ERO, and ASCOT indicated asymmetric deposition in wall structures close to the source, in accordance with experimental results. The deposition patterns were strongly affected by plasma flows, magnetic configuration, and SOL density. The SOL flows were further investigated by synthetically reproducing the measured spectroscopic signals of injected impurities at the high-field side of the vessel using ERO.

Formation and properties of mixed Be-W layers were investigated with MD simulations. Be was preferentially sputtered by plasma particles while W was sputtered by Be. The D atoms were retained in or clustered under growing surface layers. Experimentally, fuel retention was studied by exposing Be-W films into PISCES-B plasmas. The roles of porosity of Be-W mixtures as well as vacancies and helium in W were found to be significant for D retention.

Arc-discharge and plasma-sputtering methods were developed to clean plasma-facing components from co-deposited layers. The arc-discharge technique

proved to be fast but the resulting surfaces were relatively rough and showed signs of local melting. In contrast, the plasma sputtering approach resulted in smooth surfaces and excellent cleaning efficiency.

Diagnostics

In 2013, the diagnostics activities focused on the operation of NPAs at JET. The high energy NPA was not fully utilized in order to limit the formation of fast ion tails in the plasma. In contrast, the low energy NPA was actively used in RF heating and RF wall conditioning experiments. In addition, plans were made for upgrading the diagnostics during the following shutdown to make it compatible with DT campaign and ensure operational reliability. An impact assessment was also carried out to relocate NPA in Oct 8, adjacent to the NBI injector. The second important research topic was the JET neutron calibration exercise. The neutron measurements were consistent with the previous calibration done in the 1980's.

Modelling for ITER, code development and integration

2013 was the final year of the four-year Academy of Finland SimITER project. Significant progress was achieved in improving the computational efficiency of ASCOT, ERO and PARCAS by implementing modern optimization and programming practices (e.g. GPGPU) and novel multi-scale modelling methods. On the physics side, methodology was developed for accurate 3D magnetic field and first wall modelling. Recent theory work include a proper diffusion operator for anomalous transport, rotating MHD modes in real tokamak geometry, NBCD model for ITER and a guiding-center-consistent Coulomb collision operator. MD simulations, for their part, explained the mechanisms behind molecular sputtering of beryllium and tungsten fuzz formation, and produced new Be/W/C data for the ERO code to account for material mixing and potential chemical effects. Gyrokinetic modelling with Elmfire was extended towards the first wall by implementing toroidal limiters.

Work towards a highly standardized and sophisticated computing environment was continued within ITM, the most important milestone being successful parallel runs of both ASCOT4 and an earlier version ASCOT3.5 in the Kepler environment. In addition to ASCOT, the integration of BBNBI and ERO codes was continued by upgrading them into the latest ITM dataversion.

Power plant physics and technology

Power exhaust studies aim at building a database of documented plasma experiments and validated simulations. In 2013, scans of the edge plasma properties with different power dissipation levels by radiating impurities were performed using SOLPS5.0 and compared to experimental trends in N-seeded discharges in AUG and JET. N seeding allows achieving divertor radiation of ~60% of input power.

Utilizing our recently finalized Fe-Cr-C interatomic potential, the effects of carbide precipitates on the mobility of dislocations in steels were studied. Significantly large critical stresses to initiate dislocation movement at low temperatures were observed. MD simulations were used to investigate 150 keV collision cascades in bulk W. The results showed that vacancy clusters form mostly as low density areas at the center of previously liquid areas. The probability of cascade collapse was increased by slowing down the cooling rate of the heat spike.

Remote Maintenance concepts were developed for replacing divertor cassettes and cooling pipes in DEMO. The reactor design of DEMO is proposed to have 16 toroidal field coils and 16 ports in between. By designing the divertor to consist of 48 cassettes (3 per port) the need for a separate in-vessel cassette carrier is eliminated, which leads to a much simpler maintenance procedure and logistics than in ITER. A conceptual telescopic radial mover has been designed and proposed.

A common set of tools and methods are required in order to support the analysis of the DEMO plant and systems from the RAMI perspectives. RAMI work in 2013 focused in integration of the diverse input data for RAMI predictions and further analysis of the DEMO availability requirement.

Fusion for Energy and ITER

The F4E grant GRT-401 continues a long series of tests and development work of ITER divertor remote maintenance on the DTP2 platform. In 2013 RH-trials on the exchange of the central and the second divertor cassette were repeated, since the divertor cassette and its locking system have been modified substantially after the first tests. To keep the DTP2 platform and systems in operation and updated for the next phase, some refurbishment work was carried out. In the ITER contract ITER/CT/12/4300000674, the divertor cassette mock-up design was upgraded using several testing phases including a heat treatment. Already the first test led to design modifications of the locking mechanism. After heat treatment, the tight clearances of latches were affected by the heat treatment so that turning the knuckle was no more possible. As a result, the mechanism requires modifications.

Fabrication of MEMS magnetic field sensors and the design of a stainless steel enclosure continued under the F4E grant GRT-156. FEM simulations were used to find mechanical and thermal stresses due to electromagnetic loads, radiation and temperature excursions. Laboratory tests with previous generation sensors and prototype readout electronics meet the specified resolution of about 2 mT.

Solving the magnetization of ferromagnetic components in ITER constitutes a major part of the F4E grant GRT-379, which assesses the impact various magnetic perturbations on the confinement of energetic ions and on the wall power loads. In 2013, all the relevant components, including coils, the first wall, together with the TBM's and FI's, were imported from ITER as CAD drawings and reconstructed to be compatible with COMSOL. A numerically smooth and accurate scheme to evaluate the perturbation field due to the magnetized components was devised.

1. Overview of 2013 Activities

This Annual Report summarises the fusion research activities of the Finnish and Estonian Research Units of the Association Euratom-Tekes in 2013. The Estonian Research Unit was established by the Agreement between Tekes and the University of Tartu in 2007. The emphasis of the present EFDA is in exploiting JET, physics support for ITER and in DEMO activities coordinated by the EFDA department of Power Plant Physics and Technology (PPPT). In addition, Tekes Association participated in the Goal Oriented Training (GOT) programme and high-performance computing (HPC) Implementing Agreement under EFDA. ITER related technology R&D is an active area of research within the association and takes place under the responsibility of F4E – the European Domestic Agency for ITER (Joint European Undertaking for ITER and the Development of Fusion Energy – Fusion for Energy, Barcelona).

The activities of the Tekes' Research Unit are divided in the fusion physics under the Contract of Association and EFDA. The F4E R&D Grant work on magnetic diagnostics the third F4E Grant for ITER divertor maintenance continued in 2013, and a F4E Grant on modelling of fast ion wall loads in 3D geometry started in 2012. In addition, two direct ITER contracts on are on-going; one on the Divertor cassette locking system that will be tested on Divertor Test Platform (DTP2) in practise before ordering all cassettes for ITER and another one on tritium dust studies.

The Physics Programme is carried out at VTT Technical Research Centre of Finland, Aalto University (AU), University of Helsinki (UH) and University of Tartu (UT, Estonia). The research areas of the Physics and EFDA Programme are:

- Heat, particle and momentum transport, fast particle physics and plasma edge phenomena
- Plasma-wall interactions and material transport in the scrape-off layer (SOL)
- Code development and HPC activities
- Diagnostics.

Association Euratom-Tekes participated actively in the EFDA JET Workprogramme 2013 by preparing and participating in the experimental campaigns C31 and C32. Three persons were seconded to the CCFE operating team (JOC) in JET, a physicist in codes & modelling, a physicist in plasma diagnostics and a physicist in the plasma edge group. One person was seconded to EFDA-JET CSU being responsible for codes and modelling in the experimental department. Tekes provided one Deputy TFLs for Fusion Technology. Practically all physics activities of the Research Unit are carried out in co-operation with other Associations with the focus on EFDA JET work, physics support for ITER and experimental programme of ASDEX Upgrade (AUG).

Several staff mobility visits of total 858 days took place in 2013. The visits were hosted by the Associations IPP Garching (327 days, MA Art. 1.2.b collaboration), JET/CCFE Culham (235 days), VTT (18 days), DIFFER Rijnhuizen (75 days), FZ Jülich (20 days) and Chalmers Gothenburg (7 days). Other staff mobility actions were EFDA meetings (PWI, ITM, FT, TGs; 167 days) and ITPA meetings (9 days).

The Technology work is carried out at VTT and Tampere University of Technology (TUT) in close collaboration with Finnish industry. Industrial participation is coordinated by Tekes. The technology research and development is focused on the remote handling, fabrication methods for vessel/in-vessel and TF components plus some activities in ITER and JET diagnostics and JET Technology related to ILW:

- DTP2 at VTT in Tampere for remote handling of divertor maintenance and development of water hydraulic tools and manipulators and cassette locking systems
- Magnetic diagnostics based on micromechanical sensors (MEMS) for ITER
- Application of powder hot isostatic pressing (HIP) method for fabrication of ITER vessel/in-vessel and TF components
- Plasma-facing materials issues, erosion/re-deposition and material transport studies and developing coating techniques
- In-reactor mechanical testing and characterisation of materials under neutron irradiation
- Modelling of ripple losses and wall loadings for ITER
- Tritium dust studies for ITER
- Upgrading of the NPA diagnostics for JET
- Feasibility study for micromechanical magnetometers.

The two days Annual Fusion Seminar of the Association Euratom-Tekes was hosted held on a ferry between Helsinki and Stockholm. The invited speaker was Dr. Per Helander from IPP Greifswald presenting the status and plans of Wendelstein 7-X stellarator.

2. Fusion Programme Organisation

2.1 Programme Objectives

The Finnish Fusion Programme, under the Association Euratom-Tekes, is fully integrated into the European Programme, which has set the long-term aim of the joint creation of prototype reactors for power stations to meet the needs of society: operational safety, environmental compatibility and economic viability. The objectives of the Finnish programme are:

- Develop fusion technology for ITER in collaboration with Finnish industry
- Provide a high-level scientific contribution to the accompanying Euratom Fusion Programme.

This can be achieved by close collaboration between the Research Unit and industry, and by strong focusing the R&D effort on a few competitive areas. Active participation in the JET and EFDA Work Programmes and accomplishing ITER technology development Grants by F4E provide challenging opportunities for top level science and technology R&D work in research institutes and Finnish industry.

2.2 Association Euratom-Tekes

The Finnish Funding Agency for Technology and Innovation (Tekes) is funding and co-ordinating technological research and development activities in Finland. The Association Euratom-Tekes was established on 13 March 1995 when the Contract of Association between Euratom and Tekes was signed. Other agreements of the European Fusion Programme involving Tekes are the multilateral agreements: European Fusion Development Agreement (EFDA), JET Implementing Agreement (JIA), Staff Mobility Agreement and HPC Implementing Agreement. Tekes and the University of Tartu (Estonia) signed an Agreement in 2007 to establish the Estonian Research Unit under the Association Euratom-Tekes offering for Estonia a full participation in the European Fusion Programme. The fusion programme officer in Tekes is Mr. Kari Koskela. The fusion related industrial activities were co-ordinated by Tekes. The Finnish Industry Liaison Officer (ILO) is Mr. Hannu Juuso from Tekes.

2.3 Research Unit

The Finnish Research Unit of the Association Euratom-Tekes consists of research groups from VTT and universities. The HRU is Mr. Tuomas Tala from VTT. The following institutes and universities participated in fusion research in 2013:

1. VTT Technical Research Centre of Finland (VTT)
 - VTT Materials and Buildings (co-ordination, physics, materials, diagnostics)
 - VTT Industrial Systems (remote handling, beam welding, DTP2)
 - VTT Microtechnologies and Sensors (diagnostics)
2. Aalto University, School for Science (AU)
 - Department of Applied Physics (physics)
3. University of Helsinki (UH)
 - Accelerator Laboratory (physics, materials)
4. Tampere University of Technology (TUT)
 - Institute of Hydraulics and Automation (remote handling, DTP2).

The Estonian Research Unit of the Association Euratom-Tekes consists of research groups from the University of Tartu. The Head of the Estonian Research Unit is Mr. Madis Kiisk from University of Tartu.

There are three Finnish persons in the ITER IO team, in Cadarache and three Finns in the F4E staff in Barcelona.

2.4 Association Steering Committee (ASC)

The research activities of the Finnish Association Euratom-Tekes are directed by the Steering Committee, which comprised the following members in 2013:

Chairman	Angelgiorgio Iorizzo, EC, DG Research & Innovation, Research Programme Officer Unit G.6 (Fusion Energy)
Members	Simon Webster, EC, DG Research & Innovation, Head of Unit G.6 Marc Cosyns, EC, DG Research & Innovation, Principal Administrator Unit G.7 (Administration and finance) Pentti Kauppinen, VTT Harri Tuomisto, Fortum Oyj Kari Koskela, Tekes Kimmo Kanto, Tekes
HRU	Tuomas Tala, VTT
HRU (EST)	Madis Kiisk, UT, Estonia
Finnish ILO	Hannu Juuso, Tekes
Secretary	Jukka Heikkinen, VTT

The ASC had one meeting in 2013 held in Espoo, Finland, 24 October 2013. Angelgiorgio Iorizzo and Marc Cosyns from EC were present and Duarte Borba from EFDA CSU participated through the video link. All Finnish and Estonian ASC members except Harri Tuomisto and Kimmo Kanto participated in the meeting.

2.5 National Steering Committee

The national steering committee advises on the strategy and planning of the national research effort and promotes collaboration with Finnish industry. It sets also priorities for the Finnish activities in the EU Fusion Programme.

The research activities are steered by three Topical Advisory Groups for 1) physics and diagnostics chaired by Seppo Nenonen Oxford Instruments Analytical, 2) for materials research chaired by Ilkka Vuoristo, Luvata Oy and 3) for remote handling systems chaired by Olli Pohls, Hytar Oy. In 2013, the national steering committee consisted from the members of the three advisory groups.

Chairman	Janne Ignatius, CSC
Members	Henrik Immonen, Abilitas Group
	Hannu Juuso, Tekes
	Juhani Keinonen, HY
	Jukka Kolehmainen, Diarc Oy
	Mika Korhonen, Hollming Works Oy
	Risto Kuivanen/Timo Määttä, VTT
	Juha Lindén, Tekes/ELY
	Pasi Latva-Pukkila, Sandvik Underground Technology
	Timo Laurila, Tekes
	Seppo Nenonen, Oxford Instruments Analytical Oy,
	Pertti Pale, PPF Projects
	Olli Pohls, Hytar Oy
	Pentti Pulkkinen, Suomen Akatemia
	Reko Rantamäki, Fortum Oyj
	Solveig Roschier, Tekes
	Rainer Salomaa, Aalto University
	Pekka Siitonen, Metso Powdermet Oy
	Sisko Sipilä, Tekes
	Arto Timperi, Comatec Oy
	Pekka Tuunanen, Teknologiateollisuus ry
	Matti Vilenius, TUT/IHA
	Ilkka Vuoristo, Luvata Oy
Head of Research Unit	Tuomas Tala, VTT
Secretary	Markus Airila, VTT

The national steering committee had two meetings in 2013.

2.6 Finnish Members in the European Fusion Committees

2.6.1 Euratom Science and Technology Committee (STC)

Rainer Salomaa, Aalto University

2.6.2 Consultative Committee for the Euratom Specific Research and Training Programme in the Field of Nuclear Energy – Fusion (CCE-FU)

Tuomas Tala, VTT
Kari Koskela, Tekes
Marco Kirm, UT, Estonia
Madis Kiisk, UT, Estonia

2.6.3 EFDA Steering Committee

Kari Koskela, Tekes
Tuomas Tala, VTT
Madis Kiisk, UT, Estonia

2.6.4 Science and Technology Advisory Committee (STAC)

Jukka Heikkinen, VTT

2.6.5 Governing Board for the Joint European Undertaking for ITER and the Development of Fusion Energy, “Fusion for Energy” (F4E GB)

Kari Koskela, Tekes
Tuomas Tala, VTT
Rein Kaarli, MER, Estonia
Ergo Nõmmiste, UT, Estonia

2.6.6 Executive Committee for the Joint European Undertaking for ITER and the Development of Fusion Energy, “Fusion for Energy” (F4E ExCo)

Herkko Plit, Ministry of Employment and the Economy

2.6.7 Other international duties and Finnish representatives in the following fusion committees and expert groups in 2013

- Jukka Heikkinen is the Chairman of the International Programme Committee of the Plasma Edge Theory Workshop (PET).
- Taina Kurki-Suonio was the Chairman of the Local Organizing Committee on the 40th EPS Plasma Physics Conference, Espoo, Finland, July 2013.
- Mathias Groth is a member of the ITPA expert group on divertor and scrape-off layer physics. Taina Kurki-Suonio is a member of the ITPA expert group on energetic particles. Tuomas Tala is a member of the ITPA expert group on transport and confinement.
- Taina Kurki-Suonio was a member of the Programme Committee of the ASDEX Upgrade project, Max-Planck-Institut für Plasmaphysik.
- Reijo Munther is a member of the IEA Fusion Power Co-ordinating Committee (FPCC).
- Salomon Janhunen was a member of the High Level Support Team for HPC-FF until 31 March 2013 and was replaced with Tuomas Korpilo from 1 April 2013.
- Jukka Heikkinen is a Comments Editor of *Physica Scripta*.
- Markus Airila is the Tekes administrative contact person in EFDA JET matters and representative in EFDA Public Information Network (PIN).
- Hannu Juuso is an Industry Liaison Officer for F4E and Pertti Pale is a consultant for Fusion-Industry matters.
- Harri Tuomisto is a member of the Fusion Industry Innovation Forum Management Board (FIIF MB).
- Taina Kurki-Suonio and Tuomas Tala are members of the Committee for Nuclear Energy Research Strategy in Finland, set by the Ministry of Employment and The Economy.
- Taina Kurki-Suonio was appointed as an affiliated professor in physics, in particular plasma physics (2014–2016) at Chalmers University of Technology, Gothenburg, Sweden, on 27 November, 2013.
- Taina-Kurki-Suonio was a member of the following dissertation committees in Chalmers University of Technology, Gothenburg, Sweden:
 - Gergely Papp, 12 June, 2013, Department of Applied Physics.
 - Robert Nyqvist, 26 September, 2013, Department of Earth and Space Sciences.

2.7 Public Information Activities

Fusion Expo was hosted by the Science Centre AHHA Tartu, Estonia, 17 May – 31 July 2013. Fusion Expo is a travelling exhibition designed to be accessible to the general public, presenting various aspects of fusion as an environmentally acceptable, safe and sustainable energy technology. In a clear and simple way it explains the fundamentals of fusion, describes Europe's fusion research facilities, introduces the ITER project, and looks ahead to the construction of a working fusion power plant.

The two days Annual Fusion Seminar of the Association Euratom-Tekes was held on M/S Silja Serenade and included an excursion to the Alfvén laboratory at the Royal Institute of Technology, Stockholm, Sweden. The invited speaker was Prof. Per Helander from IPP Greifswald presenting the status and future plans of the Wendelstein 7-X stellarator that is being built right now and will start plasma operation in 2015. The number of participants was 48.

The Annual Report of the Association Euratom-Tekes, *Fusion Yearbook 2012*, VTT Science **30** (2013) 193 pp. was published for the Annual Seminar and distributed to Head of Research Units and key persons of the Euratom Associations, EFDA and F4E.

During 2013, Finnish and international media published several articles and interviews on the fusion research activities in Finland:

- *Supergaafi: Tähtien voimaa atomeista (Supergraph: Star power from atoms; Markus Airila was interviewed for the content)*, Tekniikka & Talous, 1 February 2013.
- Otto Asunta, interview on supercomputing in the TV magazine *Puoli seitsemän*, YLE TV1, 27 March 2013.
- Hannu Juuso and Tuomas Tala, *Fuusioenergia on jo työmaavaiheessa (Fusion energy already in construction phase)*, interview in Suomen Kuvalehti on 22 May 2013.
- Timo Määttä, *Fuusioenergia on myös suomalaisprojekti (Fusion energy is also a Finnish project)*, interview in Energiauutiset, 28 June 2013.
- *Otaniemessä ratkotaan fuusion ja avaruuden arvoituksia (Mysteries of fusion and space are solved in Otaniemi)*, press release of Aalto University on the 40th EPS Conference on Plasma Physics, 1 July 2013.
- *Fuusioreaktorin huoltojärjestelmää suunnitellaan Tampereella (The maintenance of a fusion reactor is being designed in Tampere)*, Turun Sanomat on Henrik Bindslev's visit to VTT Tampere, 4 July 2013.
- *Fuusioenergiaa riittäisi viideksi miljardiksi vuodeksi (Fusion energy would suffice for five billion years)*, Aamulehti 4 July 2013.

- Timo Määttä, *Fuusioenergia on myös suomalaisprojekti (Fusion energy is also a Finnish project)*, interview in Aamulehti, 4 July 2013.
- *Pieni aurinko loistaa kohta Ranskassa (A small Sun will soon shine in France)*, Demokraatti on Henrik Bindslev's visit to VTT Tampere, 11 July 2013.
- *Fuusiovoimaa aiotaan valjastaa teollisiin tarpeisiin (Fusion power is harnessed for industrial needs)*, STT on Henrik Bindslev's visit to VTT Tampere, 23 July 2013 (also in Ilkka, Kauppalehti, Pohjalainen and Turun Sanomat).
- VTT, *Overhead costs of fusion power plants can be reduced by planning reactor maintenance and structure together*, press release on VTT's activities in remote maintenance of fusion reactors, 12 August 2013.
- *Edistysaskel ydinvoimaan – Fuusiovoimalan käyttöastetta voi parantaa merkittävästi (A step forward in nuclear power – the availability of a fusion power plant can be improved significantly)*, Talouselämä on VTT's press release, 12 August 2013.
- Pertti Pale and Hannu Juuso, *Vain muutaman minuutin tähden (For a few minutes only)*, interview on Finnish industry in ITER, Keski-suomalainen & Savon Sanomat, 12 August 2013.
- Mikko Siuko, *Uudessa fuusioreaktorissa on 7 kertaa kuumempaa kuin Auringon ytimessä (It is 7 times hotter in the new fusion reactor than in the core of the Sun)*, interview on remote handling in ITER, Helsingin Sanomat, 17 August 2013.
- *An airport for JET*, EFDA Picture of the Week featuring the work of the JOC secondee Kalle Heinola on 19 August 2013.
- *Overhead costs of fusion power plants can be reduced by planning reactor maintenance and structure together*, Phys.Org on VTT's press release, 27 August 2013.
- *Design rules to simplify running of fusion reactors*, the Engineer on VTT's press release, 28 August 2013.
- Markus Airila, *ITER on ihmiskunnan haastavin tieteellinen koe (ITER is the most challenging scientific experiment of mankind)*, interview in Luonnon-tietelijä 4/2013, 20 September 2013.
- Tuomas Tala, *Fuusio koe tuotti kerran merkittävästi energiaa (Fusion experiment produced for once a significant amount of energy)*, interview on NIF results in Helsingin Sanomat, 9 October 2013.

Lecture courses at the School of Science in the Aalto University:

- *Fundamentals of plasma physics for space and fusion applications* (T. Kurki-Suonio, A. Snicker and E. Hirvijoki, spring 2013).
- *Fusion energy technology* (M. Groth and A. Järvinen, fall 2013).

2.8 Funding and Research Volume 2013

In 2013, the expenditure of the Association Euratom-Tekes was about €4.4 million including Staff Mobility actions and F4E & ITER contracts (see Figure 2.1). The major part of the national funding comes from Tekes. The rest of the national funding comes from other national institutions, such as the Finnish Academy, research institutes and universities participating in the fusion research (VTT, Aalto, TUT, UH, LUT and UT) and from industry. The total research volume of the 2013 activities was about 50 professional man-years.

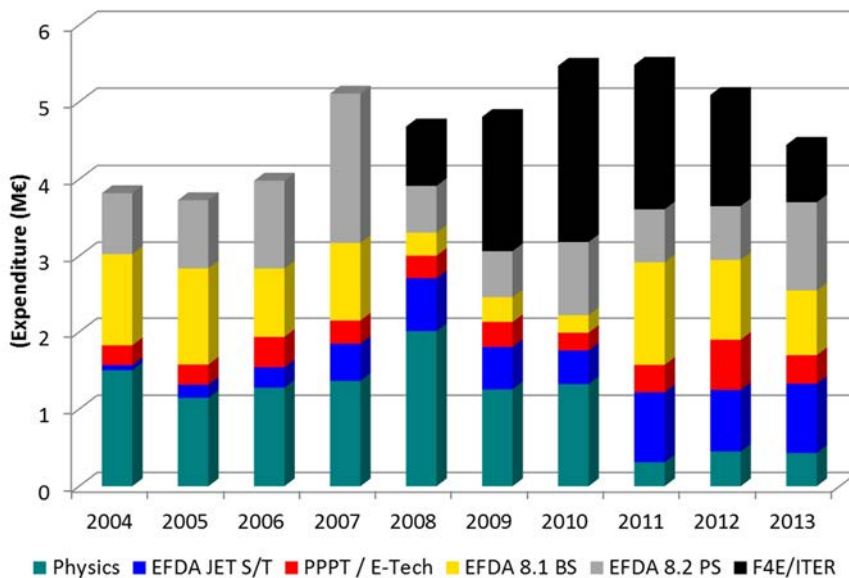

Figure 2.1. Expenditure (in M€) of the Association Euratom-Tekes for different physics and technology R&D activities in 2004–2013. The total expenditure was €4.4 million. The EFDA 8.1 and 8.2 sections cover the participation in ITM, ITER physics and PWI Task Forces, Topical Groups and GOT as well as Staff Mobility.

2.9 40th EPS Conference on Plasma Physics

A particular highlight in 2013 was the EPS Plasma Physics Conference held in Espoo. The scientific merits of the Association were notably recognized by the plenary talk of A. Hakola (VTT) on impurity migration in tokamaks. The LOC was chaired by T. Kurki-Suonio (AU). The venue was Dipole Congress Centre in Otaniemi Campus just a few kilometres from the downtown Helsinki. We have collected some feelings from the conference in Figure 2.2–Figure 2.5.

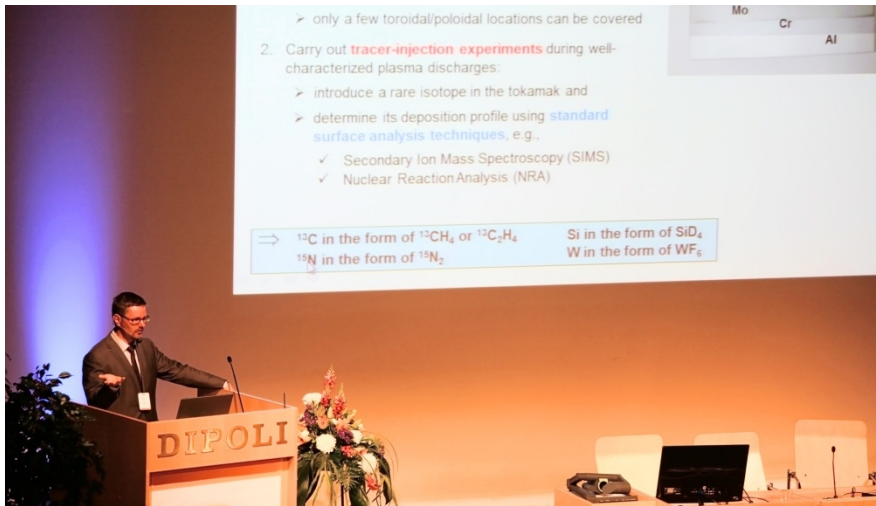

Figure 2.2. One of the plenary speakers of the conference was Antti Hakola. He reviewed the past 10 years of experiments and modelling on material migration.



Figure 2.3. The 2013 Hannes Alfvén Price was awarded to Prof. Miklos Porkolab (MIT) for his seminal contributions to the physics of plasma waves and his key role in the development of fusion energy. The 2013 EPS Plasma Physics Division PhD Research Awards were awarded to Elena Nedanovska (QUB, UK), Frederico Fiúza (IST, Portugal), István Pusztai (Chalmers, Sweden) and Lidia Piron (Padua, Italy).



Figure 2.4. Seventeen footballers and a couple of fans gathered to Otaniemi Stadium on a hot Wednesday afternoon 3 July when South took on North. The audience got to witness plenty of beautiful passing, excellent goalkeeping, and well-taken goals in a match that North won with the slenderest of margins. Most importantly, everyone present had a good time. A. Macchi (South) and O. Asunta (North) fighting fiercely for the ball.



Figure 2.5. It was fun while it lasted! The Hannes Alfvén Prize winner Miklos Porkolab shows his appreciation to the Finnish LOC at the Conference Dinner in Wanha Satama.

3. EFDA Fusion Physics and Materials Research

VTT Materials and Buildings

Dr. Tuomas Tala (HRU), Dr. Leena Aho-Mantila, Dr. Markus Airila, Dr. Paul Coad, Dr. Antti Hakola, Dr. Jukka Heikkinen (Project Manager), MSc. Juuso Karhunen, MSc. Seppo Koivuranta, Dr. Jari Likonen (Project Manager, Deputy TFL), Dr. Antti Salmi, MSc. Paula Sirén

VTT Microelectronics and Sensors

Dr. Jukka Kyynäräinen (Project Manager), Dr. Henry Rimminen, Dr. Jaakko Saarilahti

VTT Industrial Systems

MSc. Toni Ahonen, MSc. Dario Carfora, MSc. Jorma Järvenpää, MSc. Miikka Karhu, Prof. Veli Kujanpää, MSc. Harri Mäkinen, Prof. Timo Määttä, MSc. Hannu Saarinen, Lic.Sc. Mikko Siuko, MSc. Romain Sibois, MSc. Risto Tuominen, MSc. Peetu Valkama

Aalto University (AU) School of Science

Prof. Mathias Groth (Head of Laboratory), Prof. Rainer Salomaa, Dr. Pertti Aarnio, MSc. Otto Asunta, MSc. Eero Hirvijoki, Dr. Salomon Janhunen, MSc. Aaro Järvinen, Dr. Timo Kiviniemi, MSc. Tuomas Korpilo, MSc. Tuomas Koskela (JOC), Dr. Taina Kurki-Suonio, Dr. Susan Leerink, Dr. Johnny Lönnroth (CSU), MSc. Toni Makkonen, MSc. Juho Miettunen, Dr. Marko Santala (JOC), Dr. Seppo Sipilä, MSc. Antti Snicker, MSc. Simppa Äkäslompola
Students: Eetu Ahonen, Alejandro Fernandez, Tomi Kiviniemi, Ville Lindholm, Paavo Niskala, Heikki Nurmi, Tuuli Pyy, Konsta Särkimäki, Alpo Välimaa, Henry Ylitie

University of Helsinki (UH) Accelerator Laboratory

Prof. Juhani Keinonen (Head of Laboratory), Prof. Kai Nordlund (Project Manager), Dr. Tommy Ahlgren, Dr. Carolina Björkas, MSc. Laura Bukonte, Dr. Flyura Djurabekova, MSc. Fredric Granberg, Dr. Kalle Heinola (JOC), Dr. Krister Henriksson, MSc. Ville Jansson, MSc. Ane Lasa, Dr. Lotta Mether, MSc. Andrea Sand

Tampere University of Technology (TUT) Institute of Hydraulics and Automation (IHA)

Prof. Jouni Mattila (Project manager), MSc. Liisa Aha, MSc. Pekka Alho, MSc. Janne Honkakorpi, MSc. Tuomo Kivelä, MSc. Ville Lytykäinen, MSc. Janne Tuominen, BSc. Mikko Viinikainen, MSc. Jukka Väyrynen

University of Tartu (UT) Gas Discharge Laboratory (GDL)

Dr. Madis Kiisk (HRU Estonia), Dr. Märt Aints, Dr. Matti Laan, Dr. Aleksandr Lissovski, Dr. Peeter Paris, Dr. Jüri Raud, Dr. Aleksei Treštšalov, Dr. Indrek Jõgi, MSc. Kaarel Piip

3.1 Energy and Particle Confinement and Transport

3.1.1 Momentum transport studies on AUG and JET

EFDA Task(s): WP13-IPH-A04-P1, JET Orders and Notifications
Research scientist(s): T. Tala, A. Salmi, VTT
Collaboration: R. McDermott, C. Angioni, IPP Garching
 W. Solomon, PPPL

3.1.1.1 q-value scans on JET and AUG

Recently, several tokamaks have shown that a significant inward momentum pinch exists. Numerous experimental results have been reported on individual devices – yet no dedicated multi-machine momentum transport experiments have been performed. Now we report on dedicated scans to study momentum transport that have been carried out on JET, DIII-D, AUG, NSTX and C-Mod within the International Tokamak Physics Activities (ITPA) framework. Quantifying the parametric dependence of the momentum and particle pinch on the density gradient length and collisionality u^* and q-profile consolidates the extrapolation of the toroidal rotation for ITER.

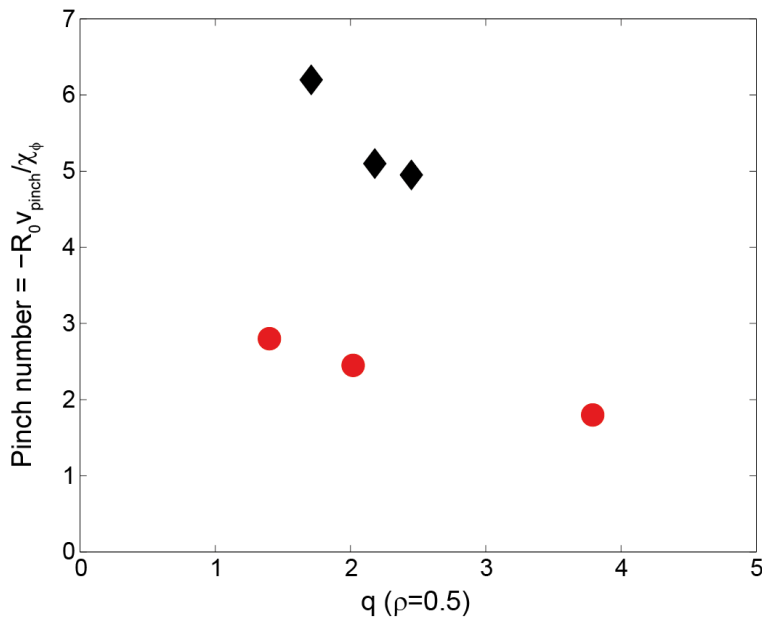

Figure 3.1. Experimental momentum pinch numbers $-R_0 V_{\text{pinch}} / \chi_{\phi}$ as a function of q value at mid-radius $\rho = 0.5$ from the 3-point q scan from JET (black diamonds) and AUG (red circles) averaged over $0.4 < r/a < 0.8$.

A 3-point q-scan was performed on JET and AUG. The magnetic field was kept at $B_t = 3.0$ T and 2.5 T on JET and AUG, respectively, while the plasma current I_p was varied from 1.5 MA to 2.5 MA and 0.4 MA to 1 MA, on JET and AUG, respectively. The result of the scan is presented in Figure 3.1 as a function of q at mid-radius. The variation of R/L_n within this 3-point q-scan was about 0.4 in JET and 0.3 on AUG. The observed weak q-dependence of the pinch number, larger than 1 unit in $-Rv_{\text{pinch}}/\chi_\phi$ in Figure 3.1 seems larger than the error bars of the analysis. One should also note that while q is scanned here, the magnetic shear s is also varied. These two effects are challenging to separate from each other in the experiment. The Prandtl numbers for the same three shots are 1.55, 1.39 and 1.81 for JET and 1.55, 1.5, 0.95 for AUG, in the descending order of q for the shots in Figure 3.1. Therefore, one can conclude that no obvious trend between the Prandtl number and q-profile was found within this scan, consistent with theory. Intrinsic torque and rotation at JET and AUG

This task concentrates on the intrinsic torque and momentum transport studies by exploiting the NBI modulation technique on AUG. The scheduled experiments on the JET tokamak were postponed due to the machine failure and subsequent delay of the experimental campaign.

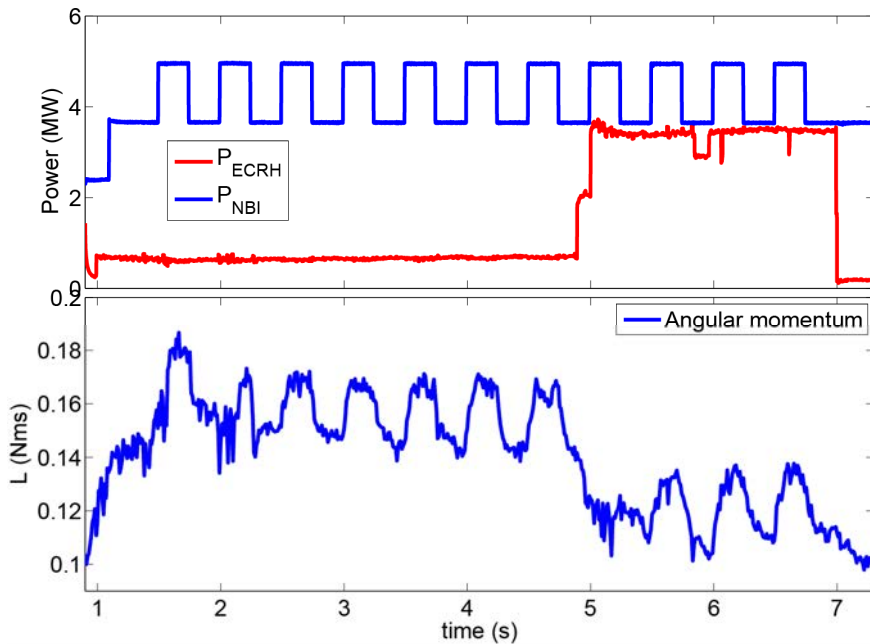

Figure 3.2. Time traces of NBI and ECRH power together with the total angular momentum of the plasma.

On AUG the effect of the q-profile on the intrinsic rotation was studied by changing plasma current from 400 kA to 1 MA while keeping toroidal magnetic field constant. This resulted in the q_{95} (q at $\rho = 0.95$) variation by almost a factor of 3 ranging from about 4 to 11. However, since the plasma density in AUG tungsten wall is strongly linked with plasma current via the Greenwald density ($n_e \approx 0.9n_G$) more heating was applied in the high current/high density cases to keep the collisionality as constant as possibly (in practise it worked to about 30%). The experimental time traces for power and rotation are illustrated in Figure 3.2.

The analysis of the rotation measurements shows that co-current intrinsic torque increases plasma current. While the trend is clear one must note that the associated error bars are also substantial. Nevertheless, all the cases have in common that the intrinsic torque has a rather broad profile with the main contribution coming from outside $\rho = 0.4$ which is somewhat different to what has been observed previously on DIII-D where the torque was quite strongly edge localised.

On the other hand, the addition of 3 MW of ECRH was seen to reduce the rotation by 30-50%. In the case of initial deep ITG regime this effect could be mainly attributed to the generation of counter current torque, while where nearer the ITG/TEM threshold, both transport changes and torque generation were needed.

3.1.2 Calculating rotation drive due to fast ions

EFDA Task(s): WP12-IPH-A04-1-22
Research scientist(s): O. Asunta, T. Kurki-Suonio, AU

The orbit-following Monte Carlo code ASCOT was used to calculate the rotation drive by fast ions in ITER 15 MA high performance H-mode scenario. Plasma rotation has many beneficial effects for the plasma performance, but it is feared to be quite modest in ITER. Rotation drive by fusion alphas as well as by on- and off-axis neutral beam injection (NBI) was studied and the contributions from collisional momentum transfer and the $\mathbf{j} \times \mathbf{B}$ torque identified. The effect of external perturbations, including toroidal magnetic field ripple, test blanket modules (TBMs) and ELM control coils (ECCs), on rotation drive was of particular interest.

It was discovered that in the ITER 15 MA scenario, the toroidal field ripple and even the TBMs have very little effect on the rotation drive due to the NBI. For fusion alphas such three dimensional magnetic perturbations do, however, modify the $\mathbf{j} \times \mathbf{B}$ torque profile significantly (Figure 3.3). Because of the dramatic effects the ECCs have on the total torque, particularly close to the last closed flux surface, accurate modeling of the magnetic perturbation due to the ECCs is of paramount importance. In this work, the so-called vacuum field approximation was used, i.e. the plasma was assumed neither to shield nor to enhance the magnetic field created by the ELM control coils. In reality, however, a contribution from the plasma is expected and should be modeled before simulating the fast ions in the resulting magnetic fields.

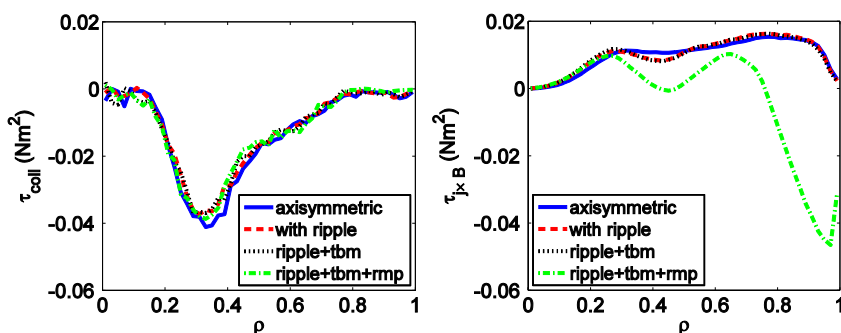

Figure 3.3. Collisional torque (left) and $j \times B$ torque (right) caused by off-axis neutral beam injection in ITER. The various magnetic perturbations have little effect on the collisional torque, but the ELM control coils increase the $j \times B$ torque significantly particularly at the plasma edge.

3.1.3 Thermal ion ripple torque and ion orbit losses in setting up boundary rotation in Tore Supra and AUG

EFDA Task(s):	WP13-IPH-A04-P1
Research scientist(s):	A. Salmi, VTT
Collaboration:	C. Fenzi, CEA Cadarache T. Pütterich, E. Viezzer, IPP Garching

Plasma rotation in ITER and future power plants cannot be controlled to the same extent with NBI as in current tokamaks. One must therefore understand all the other sources of torque and mechanisms that control the rotation at the edge of the plasma.

The effect of an asymmetric velocity distribution due to thermal ion orbit losses in AUG was studied using ASCOT code. Prior to the study some code modification and diagnostics upgrade had to be implemented. The most important ones were the poloidally resolved diagnostic for ion velocity and density and a new particle loading and weighting scheme for thermal ions to cope the SOL region. The subsequent simulations showed quite interesting poloidal asymmetries both for the rotation and for impurity density under the influence of experimental radial electric field (but without collisions). See Figure 3.4 for illustration. The asymmetry is lower than experimentally observed (by a factor of 2 roughly) but is in the right direction.

Thermal ion ripple torque is potentially an important torque source in ITER. ASCOT calculations of this torque in Tore Supra ripple showed that it can be the dominating torque source in Tore Supra when ripple exceeds 1%. The attempts to upgrade ASCOT ripple calculations to include a more accurate representation of the 3D radial electric field proved a challenge and were shown to require further input from a 3D equilibrium code.

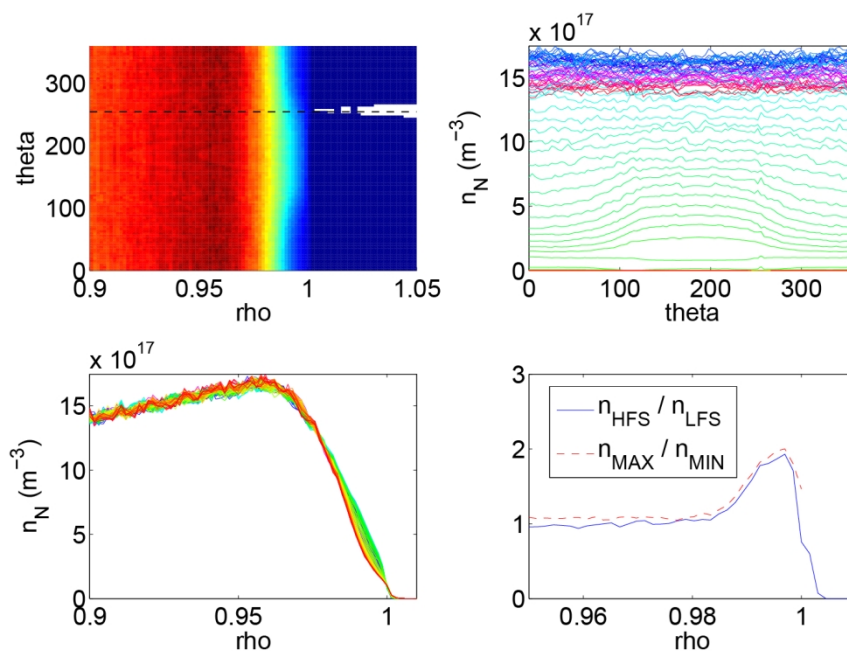

Figure 3.4. Nitrogen density under the experimental radial electric field but without collisions. Lower right frame gives the ratio of low and high field side densities.

3.1.4 European multi-tokamak intrinsic rotation database

EFDA Task(s):	WP13-IPH-A04-P1
Research scientist(s):	A. Salmi, VTT
Collaboration:	B. Duval, CRPP Lausanne F. Nave, IST Lisbon

The purpose of the effort has been to construct a database from as many machines as possible on the “best possible” toroidal and poloidal rotation profiles in the absence of external momentum input. Many machines are using beam blips to measure the intrinsic rotation component and a comparison of the basic phenomenology of rotation behaviour on tokamak machines is useful both for H-mode (c.f. “Rice Scaling”) and in, probably simpler, Ohmic discharges in both limited and diverted configurations where possible. Apart from the core scaling, the rotation gradients towards the plasma edge can be compared as a function of machine size, plasma shape, aspect ratio and plasma parameters such as temperature and density. Possible changes with ECH heating (TCV, AUG, JET) and other such phenomena can be studied as well.

JET contribution to the database has been assembled with roughly 150 time slices from over 50 different discharges. The data has been processed into a

format suitable for the MDS+ database. The first subset of the data has already been transferred and is ready for use while the rest are being cleared through the JET pinboard. This data is mainly awaiting for CXRS data reprocessing necessary for ensuring the best data quality. In particular it has been found that the results are somewhat sensitive to the method of analysis which has become an issue due to the very low rotation values in these discharges that do not include NBI. Once the data is re-processed it will be included into the database.

3.1.5 Full-f gyrokinetic simulation of edge pedestal in Textor

EFDA Task(s):	WP13-IPH-A08-P3
Research scientist(s):	T. Kiviniemi, S. Leerink, P. Niskala, AU J. Heikkinen, VTT
Collaboration:	A. Krämer-Flecken, FZ Jülich

A series of ELMFIRE simulations of plasma turbulence for TEXTOR tokamak was carried out using PRACE resources (30 million CPUh for SuperMUC). Main effort was a parameter scan where temperature, density, scale lengths of these, magnetic field and isotope were varied starting from Textor L-mode case with strong GAMs. The radial propagation velocity of GAMs was analysed using correlation analysis. As an example of parameters scans, in Figure 3.5, the fluctuations of radial electric field (mean field for each flux surface subtracted) are shown for two different isotopes in radius and time showing the effect of mass on GAM structure.

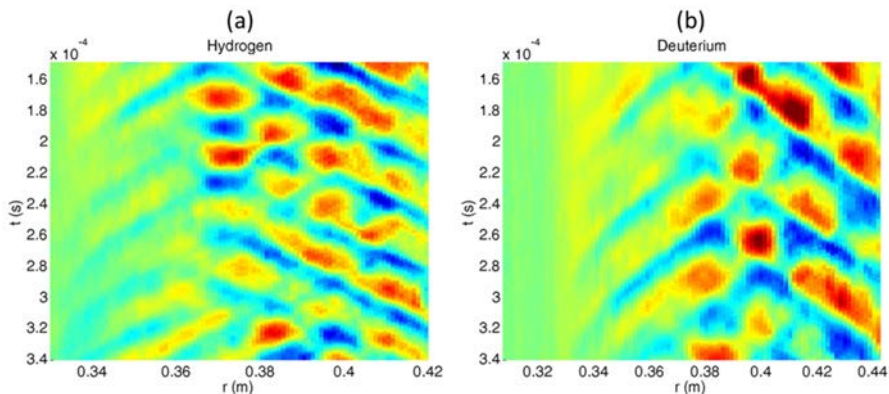

Figure 3.5. Fluctuative part of radial electric field from Elmfire simulation for (a) hydrogen and (b) deuterium plasma.

In earlier Textor experiments, $v_{r,GAM}$ was shown to decrease with increasing density (n) but temperature (T) decreased at the same time. In simulation changing n (keeping T fixed) does not change $v_{r,GAM}$ while changing T changes $v_{r,GAM}$. Thus,

we conclude that changes in $v_{r,GAM}$ are not because of density but because of temperature. A clear correlation between E_r and transport coefficients was found in the simulations and the phase shift between E_r and ion heat transport coefficient was observed to decrease with increasing T (while E_r vs D did not have clear dependence). Also, radial wave lengths of GAMs were shown to be in good agreement with analytic theory. The effective ExB shear due to oscillating radial electric field can be seen also directly from data and was found to reach values which may affect the transport levels.

3.1.6 JET and JT-60U current profile modelling with identity plasma experiments: the effect of equilibrium in JET

EFDA Task(s):	JET Orders and Notifications
Research scientist(s):	P. Sirén, T. Tala, VTT
Collaboration:	J. Garcia, X. Litaudon, CEA Cadarache G. Corrigan, F. Köchl, CCFE

The effects of different source terms in current diffusion based on the identity experiments in JET and JT-60U, where the main plasma parameters and geometry have been mostly set to match, have been studied earlier. One of the fundamental differences was the geometry and it was not perfectly compensated in the identity experiments. Plasma geometry is connected to confinement by the standard confinement scaling law and geometrical features affect poloidal beta and non-inductive current fraction.

Three sets of simulations with different equilibrium are presented: one set with different elongation (from 1.00 to 2.00), one set with different inverse aspect ratio (from 0.2 to 0.4) and one set with different triangularity (from 0.1 to 0.4). Plasma equilibrium can be changed by changing elongation (or ellipticity), triangularity and inverse aspect ratio, if the total plasma volume has been fixed to a constant value which retains the comparability of the current fractions. The dependence of varying the plasma geometry on the bootstrap current fraction is presented in Figure 3.6.

Inverse aspect ratio affects directly the critical bootstrap current density and also the effect on the actual bootstrap current density can be seen in the flux function. Other geometrical features, mainly elongation and triangularity affect the bootstrap current density through the flux functions. The effect of elongation is negligible on the bootstrap current density. Increasing the triangularity multiplies the bootstrap current density profile with a small factor, but it does not change the current alignment. Three times larger triangularity increases bootstrap current less than 0.01 MA, and elongation does not have an effect on the flux function. As expected, increasing the inverse aspect ratio affects generating bootstrap current the most. The inverse aspect ratio multiplied by a factor two (from 0.2 to 0.4) generates almost three times larger bootstrap fraction. Changing the inverse aspect ratio does not change the shape of the bootstrap current density profile, but it has a strong effect on the derivative of the flux function. By using an almost 10 times

larger density gradient, as large a bootstrap fraction as can be achieved in JET with a larger inverse aspect ratio cannot be generated, which shows that changing the inverse aspect ratio is a more efficient way to increase the non-inductive current fraction than a strong density ITB.

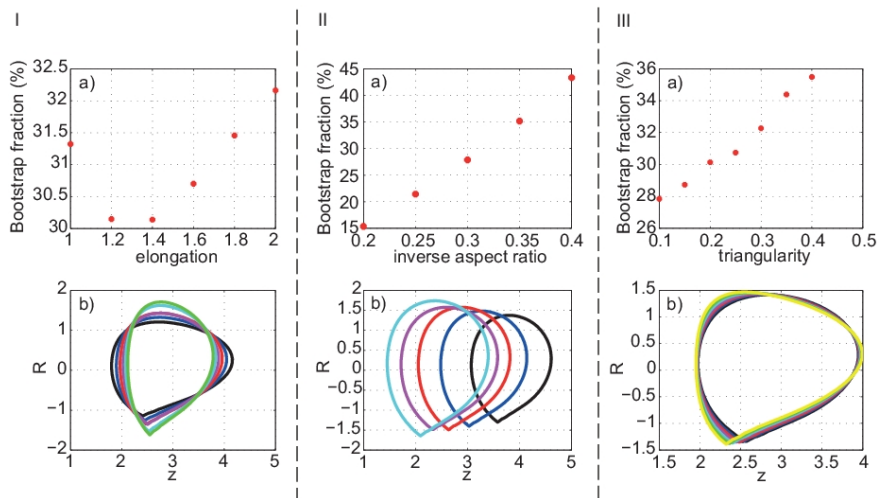

Figure 3.6. Bootstrap fraction (a) and plasma boundary (b) with different geometric parameters (I elongation, II inverse aspect ratio, III triangularity)

3.1.7 Particle pinch studies on JET

EFDA Task(s):	JET Orders and Notifications
Research scientist(s):	A. Salmi, T. Tala, VTT
Collaboration:	P. Mantica, IFP Milan L. Meneses, CCFE P. Tamain, CEA Cadarache

New JET experiments using gas puff modulation have been carried out in both L- and H-mode plasmas to study particle sources and transport both in the plasma core and in the pedestal region. The electron density response to the gas puff modulation was measured at 10 kHz sampling rate using a recently upgraded multi-band reflectometry capable of measuring full radial profiles extending well across the separatrix down to densities $\sim 2 \times 10^{17} \text{ m}^{-3}$.

In the L-mode session a 3-point dimensionless collisionality scan was performed. A simple analysis valid for a source free region is consistent with the earlier experimental database studies on JET showing virtually no collisionality dependence. Gyrokinetic quasi-linear analysis by QuaLiKiz confirms the result from the scan.

The first proof-of-principle H-mode gas modulation session in JET proved highly successful showing clear modulation (1–2% in the core) in electron density. Various gas injection locations and frequencies were tested and the strongest electron density modulation for a given gas rate was obtained with an outboard midplane injection, with a modulation that is a factor of 1.5–3 larger than the one obtained with injection from the top or from the divertor (see Figure 3.7).

Since the SOL width is narrowest at the midplane this would seem to indicate that the direct fuelling (or “convection assisted direct fuelling”) could be responsible for a significant part of the total fuelling also in JET H-mode plasmas. This is quite interesting as the common understanding is that most of the fuelling is expected to be due to recycling especially in the X-point region.

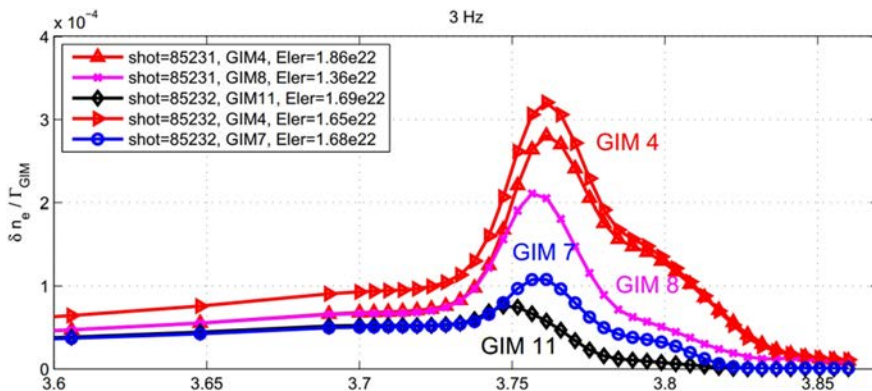

Figure 3.7. Electron density modulation amplitude with different gas injection locations.

3.1.8 Effect of TBM on plasma rotation

Research scientist(s): A. Salmi, T. Tala, VTT

Collaboration: W. Solomon, PPPL

Non-axisymmetric magnetic perturbations can lead to increased momentum, particle and energy losses through generating toroidal torque on the plasma thereby influencing plasma rotation and performance. ITER will be equipped with six Test Blanket Modules (TBMs) to study various Tritium breeding concepts. They contain significant amounts of ferritic material which will magnetise and consequently create localised 3D magnetic perturbations.

The effect of TBMs on the plasma rotation was studied on DIII-D tokamak with a 5 Hz sinusoidal modulation of the TBM mock-up coil currents. Time traces of the experimental setup are shown in Figure 3.8.

The TBM perturbation was chosen to be small enough to maintain the density and temperature nearly constant while still generating sufficient signal over the

noise. The magnitude and the phase delay of the transient could then be used to pin down the prevailing torque profile with reasonable accuracy. It was also found that momentum transport simulations best reproduce the experimental measurements when the torque is edge localised and of the order of 2 Nm in counter current direction. Furthermore the steady state data indicated that a small but non-zero counter current torque is needed also in the core plasma. Further experimental time has been allocated to study how the torque magnitude scales with plasma parameters such as collisionality using the same technique.

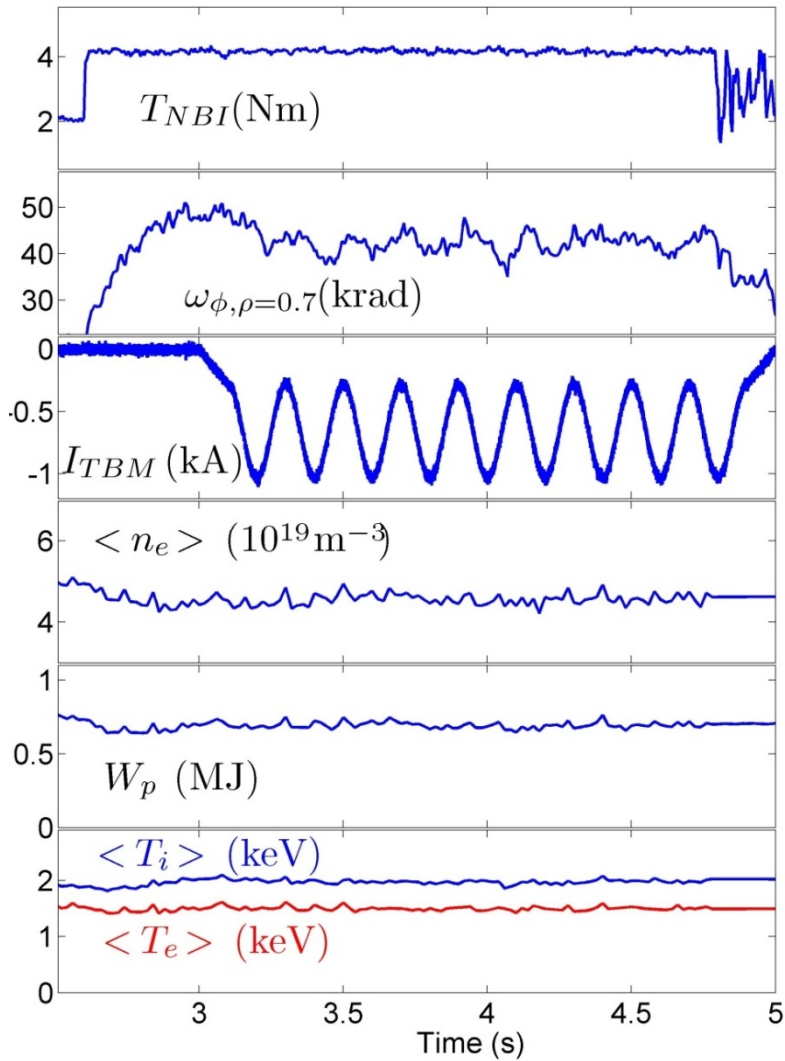

Figure 3.8. Time traces of relevant plasma parameters during the TBM modulation.

3.2 Power and Particle Exhaust, Plasma-Wall Interactions

3.2.1 Material transport and erosion/deposition in JET

EFDA Tasks:	JW13-FT-3.82, JW13-FT-4.32, JW13-FT-4.36
Research scientists:	E. Ahonen, M. Groth, A. Järvinen, T. Makkonen, AU M. Airila, J.P. Coad, A. Hakola, J. Karhunen, J. Likonen, S. Koivuranta, VTT K. Heinola, J. Keinonen, K. Mizohata, UH M. Laan, A. Lissovski, P. Paris, K. Piip, UT
Collaboration:	A. Widdowson, CCFE

3.2.1.1 Post mortem analysis of erosion/deposition on first-wall components

JET operated with an all-carbon wall (JET-C) until October 2009 and during the shutdown in 2009–2011 all the carbon-based plasma facing components (PFC) were replaced with the ITER-like wall (JET-ILW). Here we present the first results on erosion and deposition at the divertor region of the JET-ILW in 2011–2012. In this region, the analysed tiles had alternating W and Mo marker layers on carbon fibre composite (CFC), except the load bearing tiles in the outer divertor which were made of solid tungsten.

A photographic survey indicates that all the divertor tiles are very similar before and after plasma exposure. This implies that migration in the SOL towards the inner divertor – and, as a result, the production of dust – has decreased markedly from the situation during the JET-C phase. During that period, strong transport of intrinsic impurities (Be and C) and fuel (D) towards the inner vertical divertor Tiles 1 and 3 was observed. As a result of re-erosion, the material was further transported towards Tile 4 and the shadowed regions.

In the JET-ILW case, SIMS, NRA, tile profiling, and optical microscopy show that the heaviest deposition occurs on the horizontal (apron) and top parts of Tile 1. The deposits are ~5–15 μm thick and contain large amounts of beryllium but the carbon and deuterium contents are very low.

Figure 3.9 shows a SIMS depth profile and an optical microscope image from the apron of Tile 1. A ~5 μm thick, Be-rich surface layer can be observed, but the underlying tungsten and molybdenum layers seem to be mixed. SIMS depth profiles from the top part of Tile 1 show even more severe mixing of beryllium, tungsten and molybdenum down to a few tens of microns. The mixing of the signals could be, e.g., due to large roughness of the tiles. Both SIMS and RBS show that the lower front face of Tile 1 and the plasma facing surface of Tile 3 is relatively clean with no significant beryllium deposits.

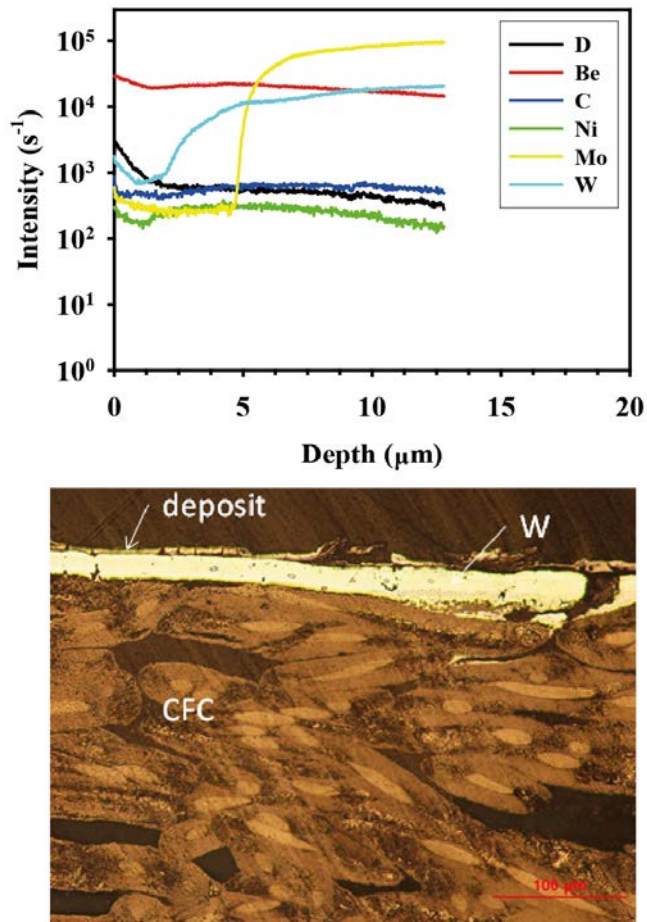

Figure 3.9. SIMS depth profiles (top) and optical microscope image (bottom) from the apron of Tile 1.

In the case of Tiles 4 and 6, NRA and SIMS indicate beryllium-containing layers with only small amounts of deuterium on their surfaces. Figure 3.10 shows the SIMS depth profiles from the sloping part and the shadowed region of Tile 4. On the sloping part, a thin ($< 1 \mu\text{m}$) Be surface layer with little D is observed while the shadowed region showed a clear discrete layer with somewhat more Be and D.

The outer divertor tiles 7 and 8 are normally a region of slight net erosion and the tiles exposed during both the JET-C and JET-ILW phases are very clean.

First post-mortem analyses clearly show that the migration from the vessel to the inner divertor and to the shadowed region on the divertor floor have been reduced during the JET-ILW operations. As a consequence, also the amount of trapped fuel has decreased, by a factor of over 10.

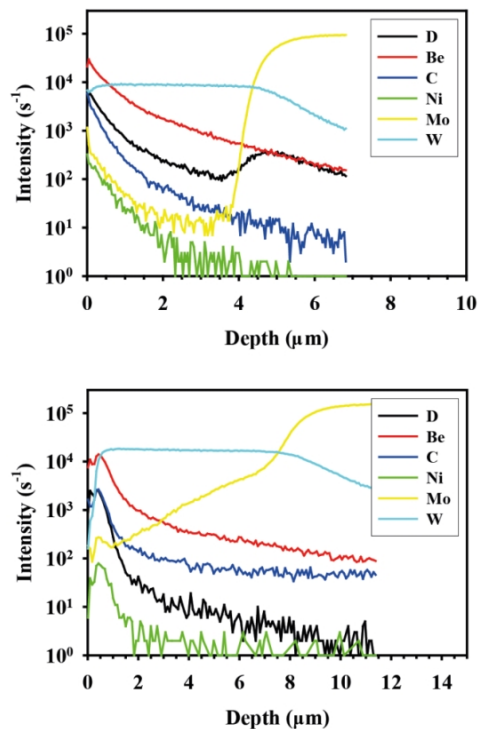

Figure 3.10. SIMS depth profiles from the sloping part (top) and the shadowed region (bottom) of Tile 4.

3.2.1.2 Developing diagnostics for *in situ* monitoring of erosion, deposition, and fuel retention

On this front, the work concentrated on the development of Laser Induced Breakdown Spectroscopy (LIBS) such that it could be used for *in situ* monitoring of hydrogen retention and local growth of deposited layers on the first-wall structures of JET. To this end, a set of samples, drilled from the inner-divertor ILW Tiles 1, 3, and 4 and having co-deposited layers on top of W or Mo marker layers, was analysed using the Be-compatible LIBS setup at VTT. The depth profiles of H/D, Be, Mo, and W were extracted from the measured LIBS spectra as a function of the number of laser pulses and the relative abundances of H/D and Be with respect to W/Mo were calculated along the entire inner divertor. The ablation rate was determined to be 50–250 nm/pulse, which provides an acceptable depth resolution. The thickest deposits with the largest amounts of H/D and Be were observed on the apron and top regions of tile 1 (see Figure 3.11). Around the apron, the films were also the richest in Be. The results were consistent with the existing SIMS data, indicating that LIBS is an applicable method for *in situ* studies in tokamaks with a metallic first wall.

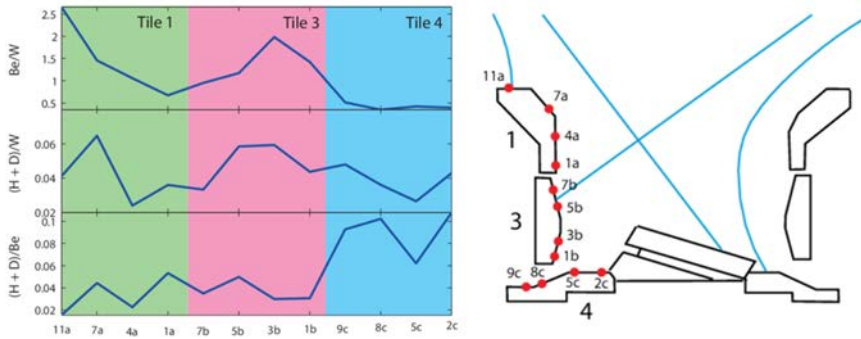

Figure 3.11. LIBS results for the poloidal profiles of the (qualitative) Be/W, (H+D)/W, and (H+D)/Be ratios on the analysed inner-divertor ILW tiles 1, 3, 4.

3.2.1.3 Modelling of ^{13}C migration in the divertor region

In 2013, global migration of impurities was studied in the divertor region of JET by combined ERO, DIVIMP, and EDGE2D simulations of the 2009 ^{13}C injection experiment. A Mach 0.5 flow had to be imposed on top of the EDGE2D solutions for the plasma background such that the backgrounds could be used in subsequent ERO simulations for methane breakup and carbon migration. The simulation volume covered the entire lower divertor of JET, and the particles that exited the volume were either re-introduced into the box or considered as lost. The reintroduction was performed by following the particles in the main-chamber SOL and core-edge boundary using DIVIMP.

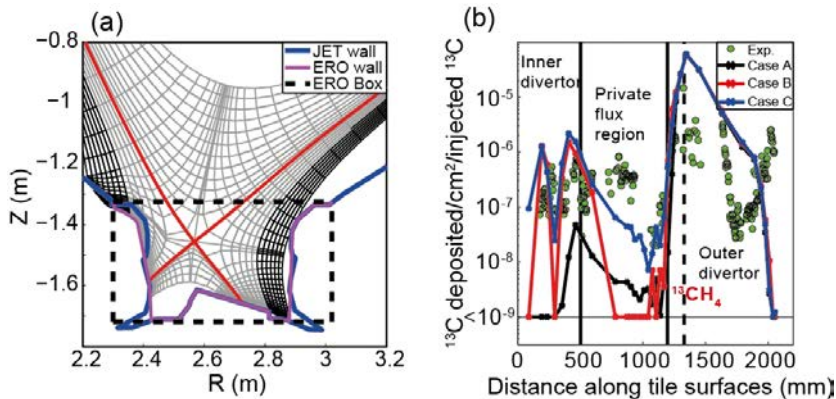

Figure 3.12. (a) Calculation grid used in ERO and DIVIMP simulations of the JET 2009 experiment together with the simulation geometry of ERO. (b) Measured and modelled deposition of ^{13}C impurities: case A = no transport via the main chamber, case B = transport activated, case C = transport and re-erosion turned on.

The simulations could qualitatively explain the strong deposition peak close to the injection valve as well as the decreasing tendency of deposition when moving away from the source along the outer divertor. Transport via the main chamber was noticed to play a large role in moving particles from the outboard to the inboard side of the torus (see Figure 3.12). In addition, re-erosion considerably modified the primary deposition profiles, as a result of stepwise migration of impurities (walking) along the PFCs (see Figure 3.13). All the deposition patterns are further altered by ELMs and other transient effects; none of them have yet been included in our studies.

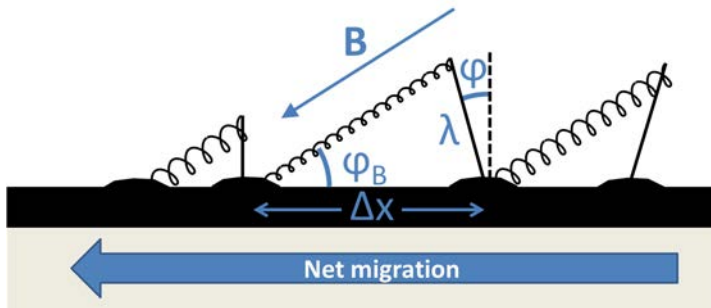

Figure 3.13. Under the influence of an oblique magnetic field, eroded impurities tend to “walk” to the direction where the angle between B and the surface is obtuse. One step consists of the ballistic trajectory of a neutral particle across B followed by the gyration of an ion along B back to the surface.

3.2.1.4 Edge modelling in support of JET programme / organisation of edge modelling activities

In ITER, partial detachment of the divertor plasma at both target plates is mandatory to warrant particle and power fluxes sufficiently low to avoid overheating of the divertor components and significant tungsten production. Predictions of the scrape-off layer conditions in JET-ILW low confinement mode plasmas using the EDGE2D/EIRENE and SOLPS5.1 fluid edge codes show a two-fold reduction in the ion currents to the low field side (LFS) target plate for both code packages when the plasma transitions from high-recycling to a partially detached regime (see Figure 3.14). These results are qualitatively consistent with Langmuir probe measurements, and are within 50% of the measured currents. However, the code results differ in predicting the peak electron temperature ($T_{e,pk,LFS}$) and the power to the LFS plate ($P_{div,LFS}$): with SOLPS5.1 the peak electron temperature remains above 1 eV and the power at several kW, while with EDGE2D/EIRENE the lowest $T_{e,pk,LFS}$ is observed at 0.3 eV and $P_{div,LFS}$ at nearly zero (Figure 3.14(b)).

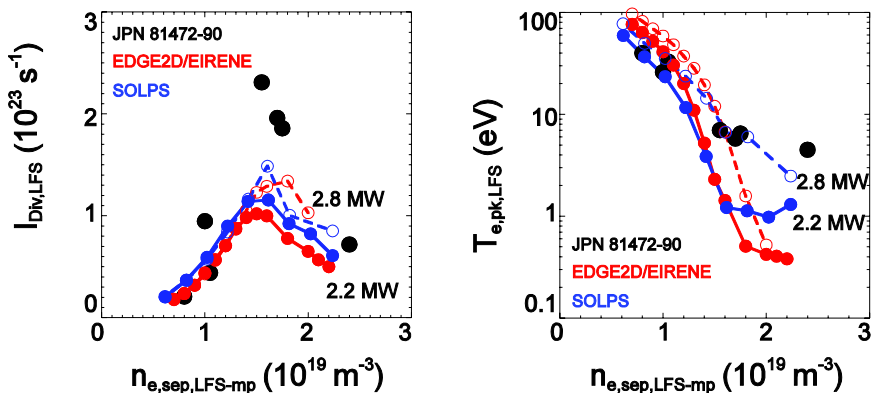

Figure 3.14. Total ion current to outer (LFS) target plate (a) and peak electron temperature (b) in JET low confinement plasmas [M. Groth *et al.*, Nucl. Fusion **53** (2013) 093016]. The experimental data is given by the solid, black circles, EDGE2D/EIRENE simulations by the red symbols, and SOLPS5.1 simulations by the blue symbols. The input power has been scanned across the innermost surface of the computational domain: solid line 2.2 MW, dashed line 2.8 MW.

Two two-week long JET edge modelling meetings were organised in April 2013 and October 2013 (led by S. Wiesen of FZ Jülich, Germany) bringing together about 20 edge modelers and experimentalists from Europe and JET, connected to specific JET experiments. Besides chairing regular meetings with the group, the primary task of these activities is to provide data analysis to those modelers unfamiliar with JET data. Specifically, during the meeting in April 2013, JET data and EDGE2D/EIRENE simulations were provided to the group of I. Duran of IPP Prague, D. Tshakaya of University of Innsbruck, A. Lasa of University of Helsinki, and K. Lawson of CCFE. A detailed analysis and publication plan was provided to the JET Task Force Leaders following each meeting.

3.2.1.5 Simulations of fuelled and seeded JET ELMy H-mode plasmas

Divertor detachment control with impurity seeding will be mandatory in the next step devices, such as ITER, to maintain divertor surface heat fluxes below 5–10 MW/m², while operating at plasma performance required for fusion gain factors in excess of 10. To address these needs, impurity injection experiments, with nitrogen and neon seeding, were conducted in JET high triangularity H-mode plasmas with 14–20 MW of input power. In this study, the fluid simulation code package EDGE2D/EIRENE was utilized to interpret the divertor radiation and plasma detachment characteristics in these experiments. The main goal is to identify the physics processes relevant for radiative divertor operation in high performance plasmas in tungsten divertor environment, as well as to provide invaluable benchmark of the fluid modelling tools against experimental observations.

Detached outer divertor target operation with enhanced plasma performance, compared to the unseeded plasmas, is obtained with nitrogen seeding in these plasmas with radiative power fraction of about 65%. Transition to nitrogen-induced detachment is also observed in the simulations when 40–60% of the power crossing the separatrix is radiated. Similarly to the experiments, also in the simulations the 2D distribution of radiation at these nitrogen injection levels was peaked around the outer divertor X-point. Also the NII atomic line intensity distribution in the simulations (see Figure 3.15(b)) was in line with the experimentally measured values (Figure 3.15(a)). The simulations show that nitrogen provides more than 85% of the total radiative power in the simulations.

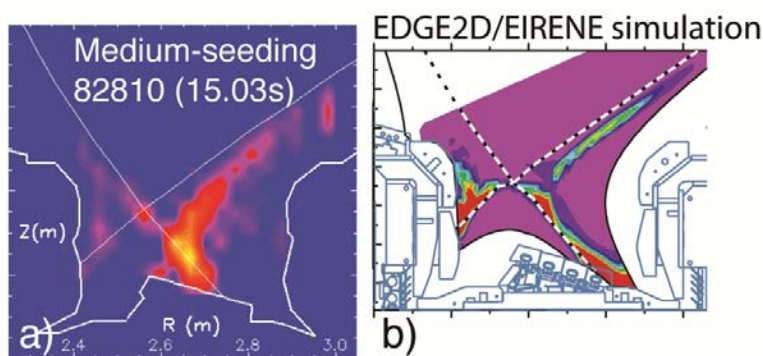

Figure 3.15. (a) Measured NII (500 nm) line-emission distribution in a high triangularity JET H-mode plasma with a medium nitrogen injection rate (here 2.5×10^{22} electrons /s). (b) NII (500 nm) line-emission in the divertor plasma simulated by EDGE2D/EIRENE. Arbitrary units are used.

3.2.2 Material transport and erosion/deposition in AUG

EFDA Tasks:	WP13-IPH-A01-P1, WP13-IPH-A03-P1
Research scientists:	M. Groth, V. Lindholm, J. Miettunen, T. Makkonen, H. Nurmi, AU M. Airila, A. Hakola, S. Koivuranta, J. Likonen, VTT
Collaboration:	A. Herrmann, K. Krieger, M. Mayer, H.W. Müller, R. Neu, V. Rohde, K. Sugiyama, IPP Garching T. Haikola, J. Kolehmainen, S. Tervakangas, DIARC-Technology

3.2.2.1 Global migration of ^{13}C and ^{15}N in the divertor and main chamber regions of AUG

In 2013, analysis and modelling of the 2011 experiment where ^{13}C and ^{15}N were injected into the AUG torus was continued. To supplement existing experimental data, the deposition of ^{13}C was determined in remote areas of the torus, and particularly large values (10^{18} – 10^{19} at/cm²) were measured below the divertor and

close to the source. The experiment itself was extensively modeled using combined ASCOT, ERO, and SOLPS simulations, and the results were reported in the plenary talk of A. Hakola at the EPS 2013 conference. SOLPS predicted almost stagnant plasma flows in the SOL, which is in sharp contradiction with experimental findings. For this reason, a strong flow (Mach 0.5) from the outer midplane towards the inner divertor was imposed on top of the SOLPS solution. ERO was then applied to follow the injected tracer molecules up to the point they became ionized; In the case of nitrogen, ERO was upgraded by implementing the breakup chain of N_2 into it. Finally, ASCOT followed the ions until they were deposited on the wall.

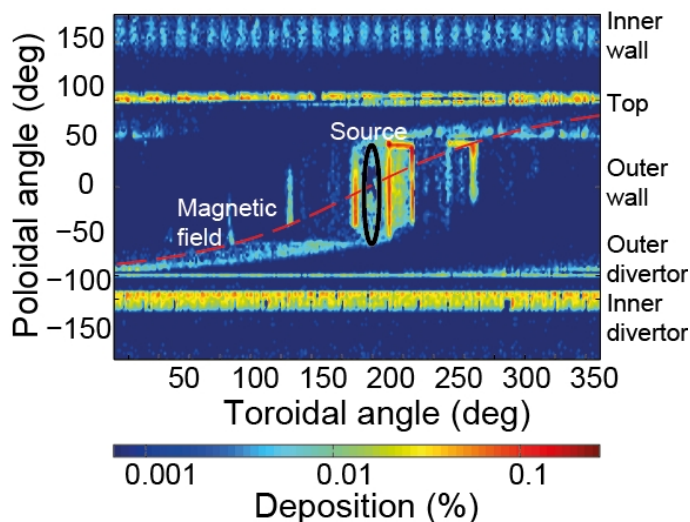

Figure 3.16. Predicted deposition profile for ^{13}C impurities, injected into high-density L-mode plasmas of ASDEX Upgrade during the 2011 experiment.

Deposition was generally asymmetric around the injection source at the outer midplane and followed the direction of the B-field, giving additional proof for the importance of flows (see Figure 3.16). In addition to the plasma flow, magnetic configuration affected the situation by increasing deposition at the inboard side of the vessel. Interestingly, the two tracers ^{13}C and ^{15}N showed different experimental deposition profiles, especially at the divertor region – while ASCOT predicts them to be next to identical. The reason is most likely connected with different surface chemistry: nitrogen levels quickly saturate on W and N thus becomes a recycling isotope in contrast with carbon.

3.2.2.2 Gross and net erosion in the divertor and main chamber of AUG

Local erosion and re-deposition of different plasma-facing materials was investigated by exposing an erosion probe to low-power H-mode plasma shots in AUG. The probe was equipped with W, Ni, Al, and C marker stripes and its tip was moved some 20 mm outside the limiter shadow for a total exposure period of 24 s. The net erosion of the different markers was measured using Rutherford Backscattering Spectroscopy (RBS). The maximum erosion of each marker material was measured close to the tip of the probe, and the values were ~ 1 nm for W and 10–20 nm for the other elements (see Figure 3.17). The results are consistent with earlier data from L-mode experiments and prove that the outer midplane is a heavy erosion zone even for W.

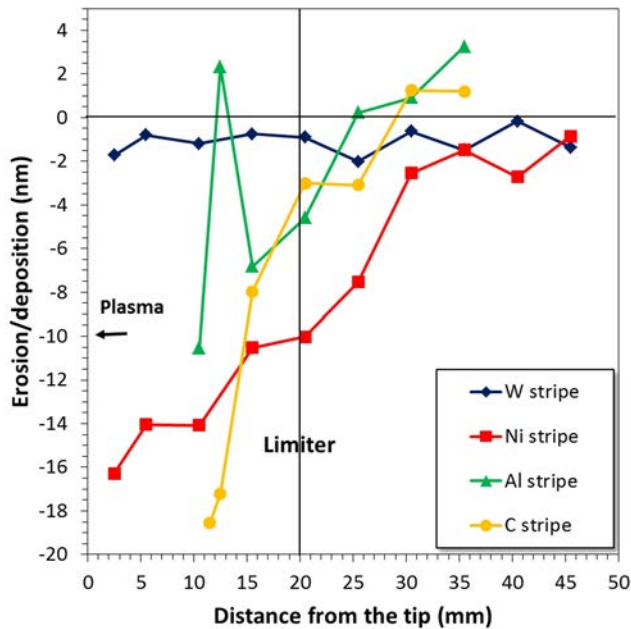

Figure 3.17. Erosion profile of the different stripes on the marker probe, exposed to H-mode plasma discharges in ASDEX Upgrade, as a function of distance from the probe tip.

Long-term erosion and deposition was investigated in the upper-divertor and inner heat-shield regions of AUG. In these regions, a set of wall tiles with W and Ni marker coatings had been exposed during the 2012–2013 experimental campaign, and the erosion of the markers was determined using RBS. Both regions were observed to be net deposition zones for W (up to 50–100 nm in 3000 s of plasma operations) while Ni showed net erosion (around 50 nm) at the upper divertor and noticeable net deposition (around 100 nm) at the heat shield.

3.2.2.3 Retention of plasma fuel in the divertor and main chamber of AUG

In 2013, fuel retention was studied by carrying out Nuclear Reaction Analyses (NRA) for the upper-divertor marker tiles discussed in section 3.2.2.2. The retention was observed to peak (up to 10^{18} at/cm²) close to the 2nd separatrix and gradually decrease towards the outermost parts of the upper divertor; at the inner side, retention was an order of magnitude smaller. No large differences were measured between the different markers except for the location of the retention peak where almost two times more D could be found on Ni than on W. The surface densities are comparable to the existing data at the inner lower divertor while at the outer lower divertor retention is generally very small (see Figure 3.18).

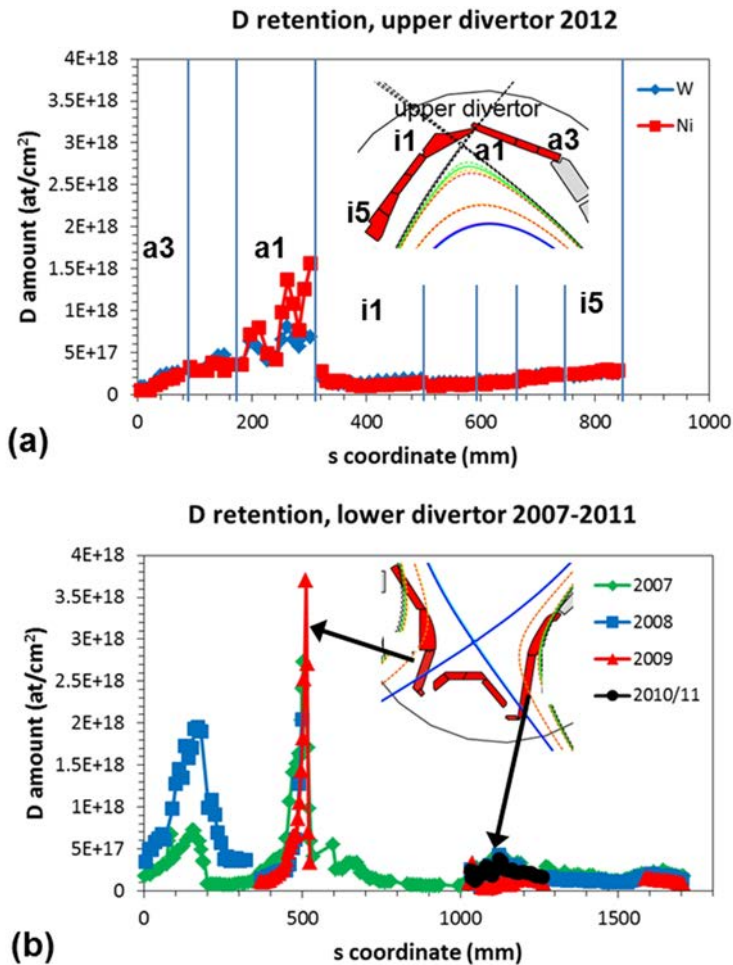

Figure 3.18. Retention of deuterium on (a) the upper divertor and (b) lower divertor marker tiles of ASDEX Upgrade.

3.2.2.4 Investigation of the HFS SOL flow in AUG

The SOL flow is crucial for impurity transport in tokamaks. To study the flow, CH_4 was injected in 2011 and 2012 at the HFS in ASDEX Upgrade and the CII and CIII emission observed with a camera and a Doppler spectroscopy system. This method was able to provide a sufficient signal from the SOL. Observing the flow of injected CII and CIII is, however, only an indirect measurement of the hydrogenic background flow. The observed flow of CII/CIII is affected by at least ionization times, equilibration times, radial profiles in the SOL, and 3D effects of the observation system.

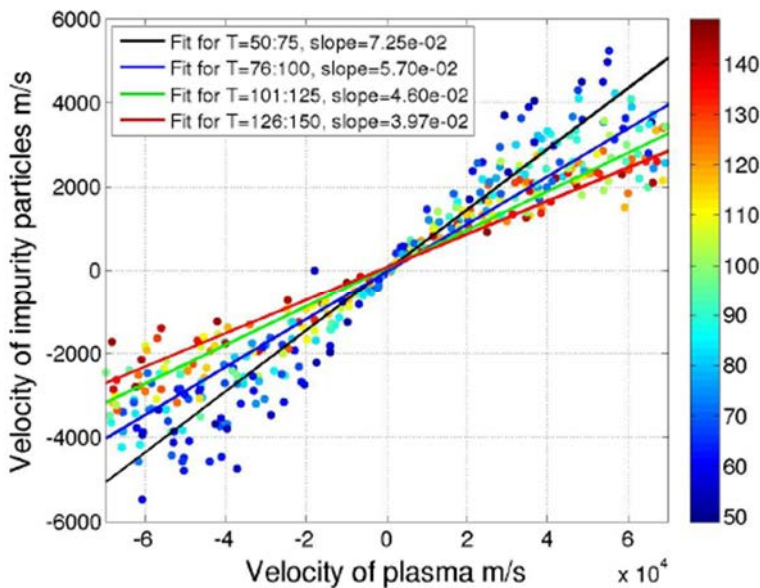

Figure 3.19. The observed velocity of CIII as a function of the hydrogenic plasma velocity at the line-of-sight. Each data point is a simulation with different SOL parameters. This plot is done for the maximum intensity peak, close to the separatrix. The colors indicate the separatrix temperature.

A large number of simulations were conducted with ERO to study the equilibration. The density, temperature, and flow were varied in the SOL within realistic values, and the spectroscopy signal was synthetically reproduced. Close to the separatrix, CII and CIII only picks up a fraction of the background flow velocity, but there is clear, linear correlation. This correlation is unaffected by density. Higher SOL temperatures decrease the equilibration. Figure 3.19 shows the observed CIII velocity as a function of the hydrogenic plasma velocity at that line-of-sight for various assumed separatrix temperatures. Closer to the wall, in a cooler plasma, the equilibration rate is higher.

3.2.3 Collaboration with IPP Garching and FZJ on fluid edge modelling: code updates, comparison to experimental data from AUG and JET

Research scientist(s): E. Ahonen, M. Groth, A. Järvinen, J. Karhunen, V. Lindholm, AU
M. Airila, A. Hakola, VTT

Collaboration: D. Coster, M. Wischmeier, IPP Garching
S. Wiesen, FZ Jülich

Collaboration with IPP Garching and FZ Jülich continued on data analysis toward SOLPS and EDGE2/EIRENE simulations. Two undergraduate AU students and one graduate student were trained to run SOLPS for JET (E. Ahonen; section 3.2.1.4) and AUG (V. Lindholm, J. Karhunen) and compare their results to experimental data from JET and AUG. The SOLPS runs for AUG represent the background plasma solutions for ERO and ASCOT simulations to simulate carbon and nitrogen migration (section 3.2.2.1). Furthermore, EDGE2D/EIRENE simulations of the 2009 ^{13}C experiments in JET produced the background plasma solutions for detailed ERO and DIVIMP trace-impurity simulations (section 3.2.1.3).

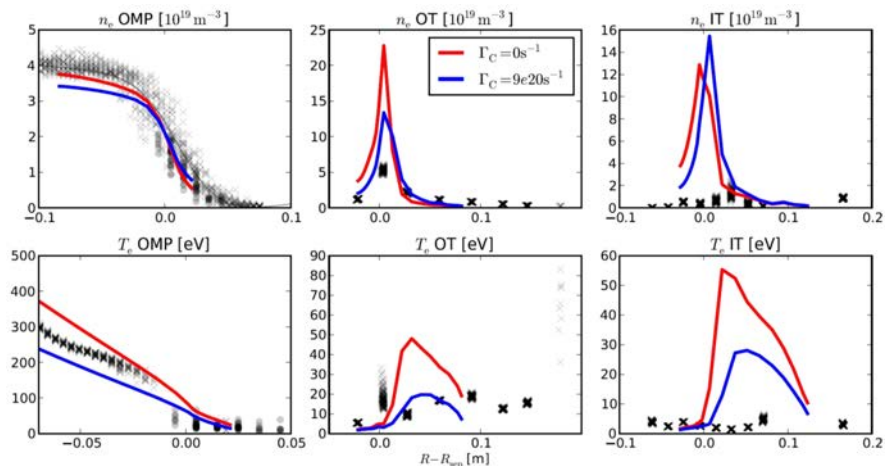

Figure 3.20. Overview of n_e and T_e profiles with and without the carbon puff.

Detailed parameter variations of the outer midplane electron temperature were performed with SOLPS5.0 for the 2011 ^{13}C and ^{15}N injection experiments (section 3.2.2.1). Both the upstream density at the separatrix and the power transport from the unaccounted core plasma were varied systematically. The analysis showed that values of $n_{e,\text{sep}}$ of $2.25 \times 10^{19} \text{ m}^{-3}$ and P_{core} of 1.6 MW reproduced the n_e and T_e profiles at the OMP and the outer divertor target. Although the variations gave a fairly good match at the OMP and outer divertor, the solution at the inner divertor was not close to the measured profiles: SOLPS overestimates the electron density and temperature at the inner target by an order of magnitude (see Figure 3.20).

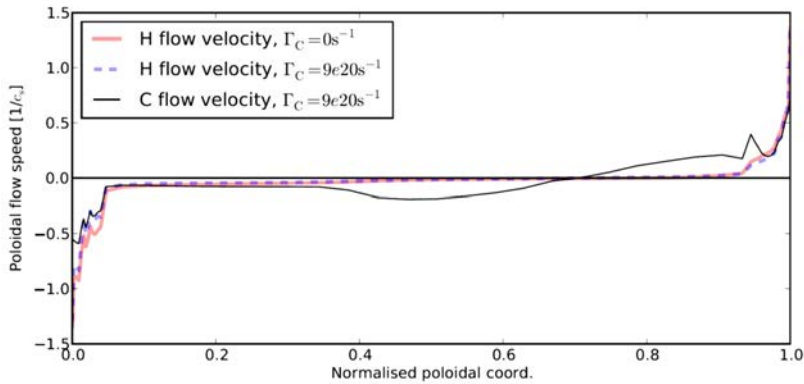

Figure 3.21. Bulk plasma and C^+ flow speed poloidal profiles. Negative values are towards the inner divertor, positive values towards the outer divertor. The bulk plasma flow profile is virtually identical when adding the carbon injection.

The flow from the LFS to the HFS was severely underestimated in SOLPS (see Figure 3.21). This behaviour has been documented before, and was also a point of concern in the previously performed ASCOT simulations. Carbon injected via the EIRENE interface into the b2 background was deposited mostly on the vessel wall, close to the injection point. This result agrees with the ASCOT simulations and the experimental measurements. However, the divertor asymmetry in SOLPS is opposite the experimental measurements: more carbon reaches the outer divertor than the inner divertor (see Figure 3.22). This is most likely due to the inefficient parallel transport due to the low SOL flow.

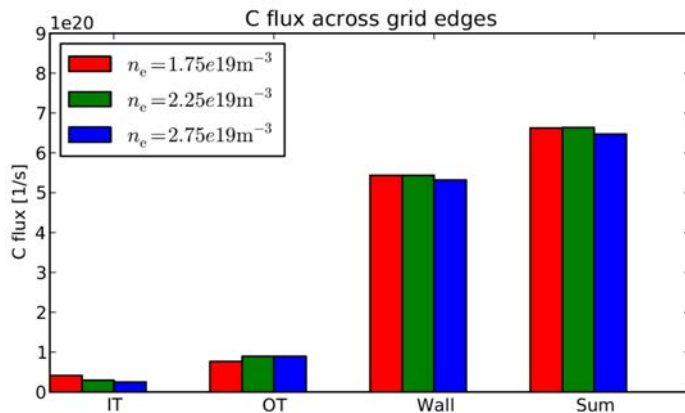

Figure 3.22. The carbon flux (all ionization stages) at the inner and outer divertors (IT and OT) and the outer grid edge. The outer grid edge is treated as being the outer wall, even if the grid does not extend all the way there. The upper limit of the y axis is set to 9×10^{20} 1/s, which is the injection flux.

3.2.4 Collaboration with General Atomics/DIII-D/ Lawrence Livermore on fluid edge code simulations with and without Monte Carlo neutrals for pedestal fuelling

Research scientist(s): M. Groth, AU
Collaboration: A. McLean, LLNL
C. Tsui, University of Toronto
J. Canik, ORNL
X. Bonnin, University of Paris

M. Groth participated onsite in a DIII-D experiment on detachment in May 2013. These experiments included a fuelling/upstream density scan to achieve low-recycling, high-recycling and detached scrape-off layer regimes. These plasmas were diagnosed with an improved divertor Thomson scattering system (A. McLean) and two reciprocating probes, one of which probed the inner divertor X-point region (C. Tsui). These measurements, obtained in low confinement and also high confinement mode plasmas, form the basis for a coordinated validation and cross-code comparison between UEDGE (LLNL), SOLPS5.0 (J. Canik) and SOLPS5.1 (M. Groth, X. Bonnin). Currently, SOLPS5.1 is set up for previous L-mode cases in DIII-D from 2004.

3.2.5 Erosion and fuel retention properties of mixed beryllium-containing materials

EFDA Task(s): WP13-IPH-A01-P1, WP13-IPH-A01-P2, WP13-IPH-A01-P3
Research scientist(s): A. Hakola, J. Karhunen, VTT
C. Björkas, N. Juslin, A. Lasa, K. Nordlund, UH
M. Laan, A. Lissovski, P. Paris, K. Piip, UT
Collaboration: C. Lungu, C. Porosnicu, MEdC, Bucharest
I. Jepu, R. Doerner, UCSD, San Diego

3.2.5.1 MD simulations of the erosion of Be and W

The enhanced re-erosion of Be was investigated by carrying out MD simulations of 50 eV, (0–10%) Be-seeded He irradiation on Be. To this end, different interatomic Be-He potentials were developed and tested. The simulations showed a constant gross Be sputtering yield (0.2 atoms/ion) and a decreasing net Be erosion when increasing the Be seeding. The MD and the experimental results – which show constant net and gross erosion as the Be fraction in the plasma rises – disagree, highlighting the need for a better description of the system.

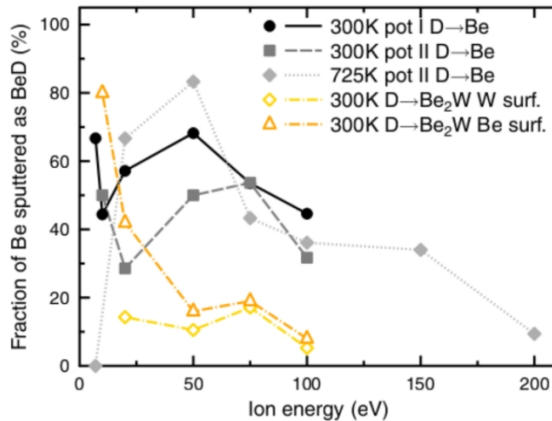

Figure 3.23. Fraction of Be sputtered as BeD, as a function of the impact energy for D irradiation on Be and Be₂W surfaces (both Be and W terminated). The substrate temperature and interatomic potential have also been varied.

To quantify the chemical erosion of Be under D irradiation, we varied the impact energy (3–100 eV) and angle (0–70°), D flux (10^{27} – 10^{28} m⁻²s⁻¹), surface temperature (200–1440 K), and D surface concentration (0–50 %) in the simulations. The results show that Be erosion peaks at impact energies of ~50 eV, mainly due to chemical sputtering. These erosion yields are suppressed when increasing the D concentration at the surface. Furthermore, the BeD sputtering does not depend as strongly on the incoming ion angle as the total Be sputtering. These results show little dependence on the D flux. The Be erosion ramps up at temperatures above 600 K, as D desorbs. A wide range of different molecules are sputtered, mainly BeD or BeD₂. Finally, the D reflection yields and sputtering of mixed W-Be surfaces were quantified by simulating D irradiation on Be₂W surfaces and varying the impact energy (7–200 eV). Our results show a preferential Be sputtering and a higher threshold for Be₂W than for Be. Furthermore, the BeD fraction is suppressed in the presence of W (see Figure 3.23).

3.2.5.2 Formation of mixed materials and trapping of deuterium in them

The effect of nitrogen in the deposition-erosion patterns of mixed W-Be layers under low energy (50 eV) nitrogen irradiation was studied by MD. The different substrates included pure materials as well as mixtures ranging from the alloy Be₂W to amorphous Be₂W, BeW, and W₂Be. Two different interatomic potentials were used to describe the interaction with N. We conclude that the N reflection yields, showing very different results depending on the potential, cannot be quantified reliably. In contrast, the erosion yields are consistent: the Be is preferentially sputtered, especially from the mixed layers. Also molecules such as Be₂N and BeN were sputtered.

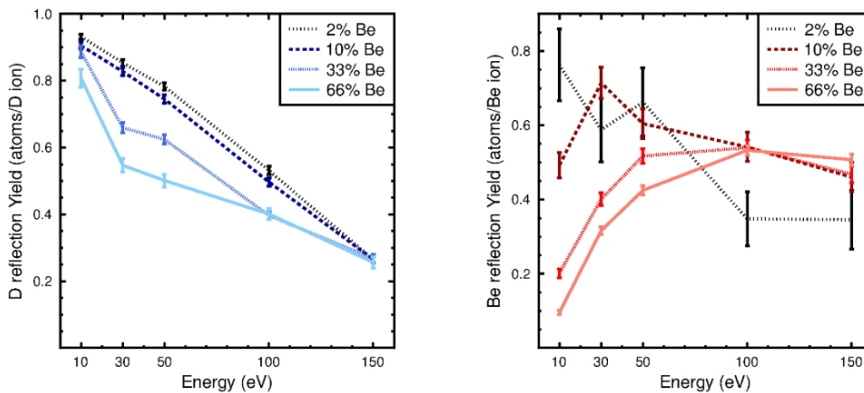

Figure 3.24. Reflection yields of D (left) and Be (right) as a function of the impact energy after Be-seeded D irradiation on W surfaces. The figure keys show the Be percentage among projectiles. The reflection yields are normalized to take into account these Be/D percentages.

Furthermore, trapping of deuterium in mixed W-Be layers was studied by simulating Be+D irradiation on W. Both simultaneous and consecutive impacts of D and Be were considered, and the impact energy (10–200 eV) and the fraction of Be (2–66%) among the projectiles were varied. During simultaneous Be+D irradiation, deuterium was implanted in the growing Be layer. The higher the Be fraction, the faster the mixed layer grows and thus more D is implanted. In contrast, consecutive Be+D impacts lead to clustering of D under the Be-rich layer deposited by Be irradiation of W surfaces. Our simulations also confirm that W sputtering is caused by Be, although this erosion is partially suppressed by Be being deposited on the surface. Furthermore, erosion shows a strong dependence on the availability of Be at the topmost layers, as it peaks at 30–50 eV and increases with the Be concentration (see Figure 3.24).

3.2.5.3 Retention of D in re-deposited Be-W layers

In the experimental front, retention of D in different mixed, re-deposited Be-W layers was investigated by Secondary Ion Mass Spectrometry (SIMS) and Laser-Induced Breakdown Spectroscopy (LIBS). The Be/W ratios of the samples were 100/0, 50/50, and 10/90 and their thickness ranged from 500 nm to 2000 nm. Half of the samples were doped with D during their deposition while the other half was left undoped and shipped to PISCES-B for exposure to D_2 plasmas.

The doped samples were noticed to contain very little deuterium (0.05–0.25 at %), independent of the composition and thickness thus making it difficult to draw conclusions on fuel retention in them. The depth profiles of other elements (Be and W), for their part, were homogeneous on all the samples. Exposure to plasmas in PISCES-B (flux $10^{23} \text{ m}^{-2} \text{ s}^{-1}$, $T_e = 3\text{--}4 \text{ eV}$, $n_e = 10^{19} \text{ m}^{-3}$) resulted in strong erosion

of pure Be while mixed Be-W samples showed hardly any erosion. In pure Be, deuterium exhibited a nice implantation profile with the main peak at 50 nm (ion energy 60 eV) whereas the D signal extended rather homogeneously throughout the entire coating of the mixed Be-W samples (see Figure 3.25). In addition to analyses, the LIBS system was developed such that it could be used for samples whose surface densities of D are below 10^{17} at/cm². The best solution seemed to be using a fiber bunch instead of a single fiber.

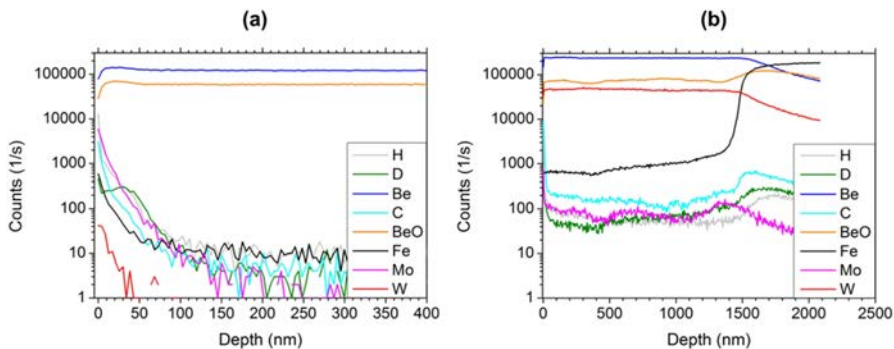

Figure 3.25. SIMS depth profiles for different elements on (a) pure Be and (b) 90%Be-10%W samples after exposure to D₂ plasma in PISCES-B.

3.2.6 Exposing W samples to Magnum-PSI and Pilot-PSI plasmas

EFDA Task(s): WP13-IPH-A03-P1, WP13-IPH-A11-P1
Research scientist(s): A. Hakola, J. Karhunen, VTT
M. Laan, A. Lissovski, P. Paris, K. Piip, UT
Collaboration: K. Bystrov, H. van der Meiden, G. De Temmerman, DIFFER
T. Haikola, J. Kolehmainen, S. Tervakangas, DIARC-Technology

3.2.6.1 Erosion and fuel retention behaviour

The work in 2013 focused on analysing W coatings (thickness 2 μm) exposed to pure D₂ and mixed D₂+He plasmas in Pilot-PSI and Magnum-PSI. In most cases, steady plasmas were used but in the Magnum-PSI experiments also ELM-like pulses (duration 0.5 ms, repetition rate 10 Hz) were applied during the exposure. In the Magnum-PSI experiments, gross erosion of the samples was studied by recording the emission light with the help of a fast visible camera, equipped with a filter for the spectral line of W around 401 nm. The spatial distribution of erosion coincided with the shape of the plasma beam on the target. The conversion to absolute units is, however, still being discussed.

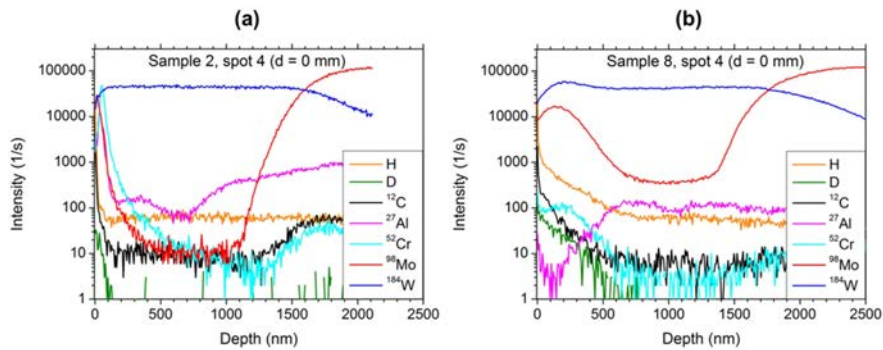

Figure 3.26. SIMS depth profiles for different elements in W samples exposed to (a) pure D_2 plasma and (b) a mixed D_2+He plasma (2:3) in Pilot-PSI. In (a), the surface temperature was $900^\circ C$ and the ion energy 40 eV while in (b), the corresponding values were $1200^\circ C$ and 70 eV.

The net erosion, for its part, was investigated by Laser-Induced Breakdown Spectroscopy (LIBS), Secondary Ion Mass Spectrometry (SIMS), and weight-loss measurements; in Magnum-PSI, LIBS was carried out *in situ* in the target exchange and analysis chamber (TEAC) without breaking the vacuum. The results indicated that for most of the samples, net deposition had taken place. The retention studies, for their part, were complicated by the broadening of H_α and D_α lines in the LIBS spectra, making it impossible to distinguish H and D from each other. Therefore, only SIMS analyses gave reliable results. The analyses showed that hardly any deuterium is retained on the surface in the case of pure D_2 plasmas whereas mixing the plasma with He turns the exposed surface black and D is readily retained in this modified layer with a thickness up to 500 nm (see Figure 3.26).

3.2.6.2 Plasma-induced surface modifications

In addition to SIMS and LIBS data, plasma-induced changes in the surface morphology of the samples were studied using Secondary Electron Microscopy (SEM) and X-ray diffraction (XRD). The most noticeable surface modifications took place at the highest surface temperatures (above $1200^\circ C$) and for the highest ion energies used (>70 eV). Under these conditions, even clear W fuzz was observed.

Especially, when the He content of the plasma was noticeable, the surface had become considerably modified and a clear surface layer rich in Mo (from the plasma source), W, and D on top of the W coating had been formed. XRD measurements indicated that the crystal structure had also changed: lattice constant had decreased from 3.168 \AA to below 3.160 \AA and the size of crystallites increased by a factor of 1.8 (from 15 nm to almost 30 nm) (see Figure 3.27).

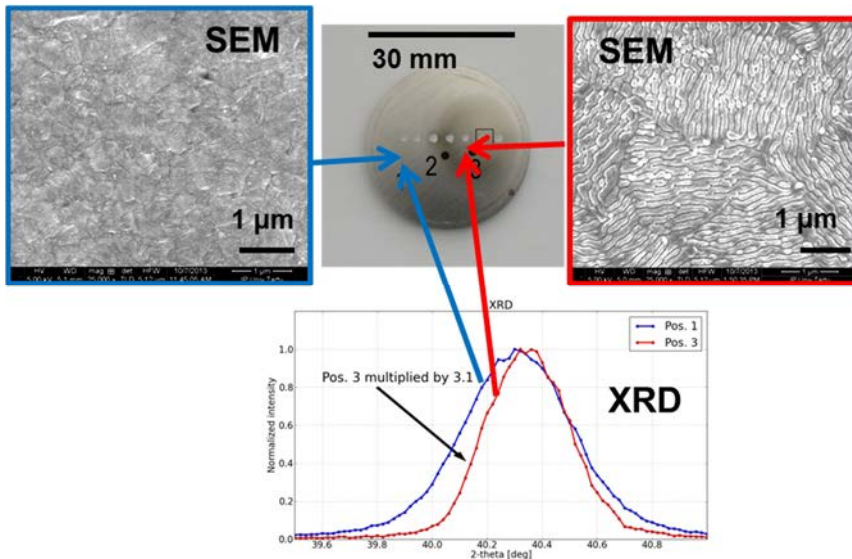

Figure 3.27. SEM and XRD graphs measured far away (blue) and at the center (red) from the Pilot-PSI plasma spot on a W sample.

3.2.7 Simulating W fuzz formation using MD

EFDA Task(s): WP13-IPH-A11-P1

Research scientist(s): A. Lasa, K. Norlund, UH

We continued the MD simulations of He and He+10%C irradiations on W surfaces. Up to 105 He (+C) impacts were modelled, also varying the surface temperature (300–1200 K). The key mechanisms for the onset of fuzz formation were identified: (i) bubble formation by He clustering and bubble coalescence; (ii) surface growth due to the loop punching (emission of prismatic interstitial dislocation loops due to the high pressure in bubbles); (iii) surface relaxation due to the bubble rupture. Furthermore, we conclude that larger bubbles ruptured at higher temperatures and in absence of impurities (C). The size of the largest ruptured bubbles increases with the fluence and C-seeded irradiation leads to higher W sputtering yields.

In the present work, these processes reached the steady state condition. Therefore, based on these processes, an Object Kinetic Monte Carlo (OKMC) code was developed extending the MD results from the nano-scale to sec-mm scales and resulting in an excellent agreement with the experimental fuzz growth rates (see Figure 3.28).

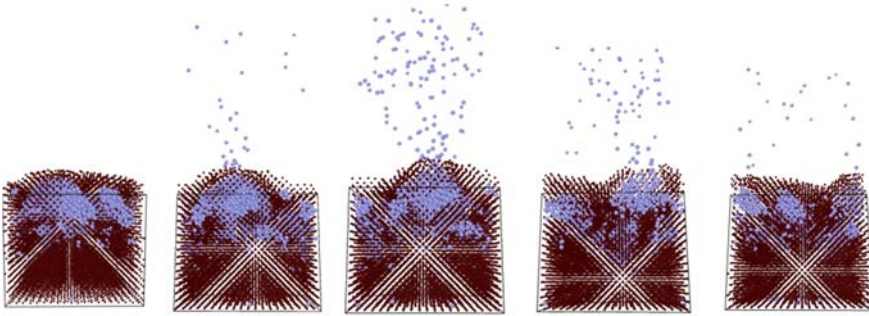

Figure 3.28. A sequence of bubble blistering during He irradiation on a W surface. A He bubble formed in W leads to surface growth by loop punching. As the irradiation continues, the bubble grows and pressure is increased, which is released by rupturing the bubble and relaxing the surface back.

3.2.8 Modelling monovacancy diffusion and fuel retention in W

EFDA Task(s): WP13-IPH-A03-P1

Research scientist(s): T. Ahlgren, L. Bukonte, K. Heinola, K. Nordlund, UH

In future fusion reactors, continuous bombardment with high energy neutrons (14 MeV) introduces defects in plasma facing materials including tungsten. Open volume defects, such as vacancies, are known to trap hydrogen (H) and thus are the main reasons for H retention in W. In fusion reactors this is a critical safety issue due to tritium retention. The migration of vacancies is the dominant mechanism behind self-diffusion in most FCC and BCC metals. It is strongly temperature dependent and is often expressed in Arrhenius form:

$$D = D_0 \exp\left(\frac{-H_v^m}{k_B T}\right), \quad (1)$$

where the migration barrier is about 1.8 eV. The prefactor is

$$D_0 = \frac{1}{6} \lambda^2 \times \nu_{\text{eff}}, \quad (2)$$

where the effective jump frequency ν_{eff} can be written as

$$\nu_{\text{eff}} = \nu_0 \exp\left(\frac{S_v^m(T)}{k_B}\right). \quad (3)$$

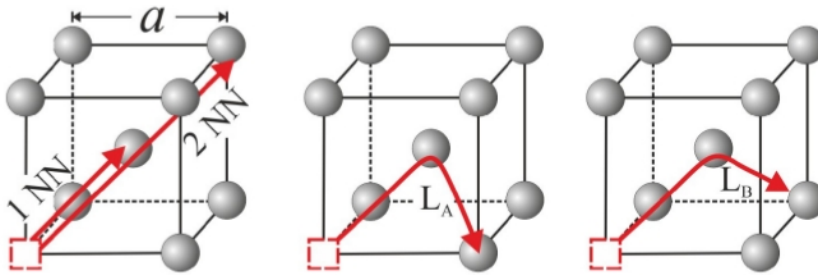

Figure 3.29. Various tungsten monovacancy diffusion mechanisms.

The molecular dynamics (MD) simulations show that the W monovacancy diffusion proceeds by multiple mechanisms, seen in Figure 3.29, where in addition to the assumed nearest neighbor jump (1NN) in the $\langle 111 \rangle$ direction, also 2NN jumps in the $\langle 111 \rangle$, and jumps in $\langle 100 \rangle$ (L_A) and $\langle 110 \rangle$ (L_B) are seen.

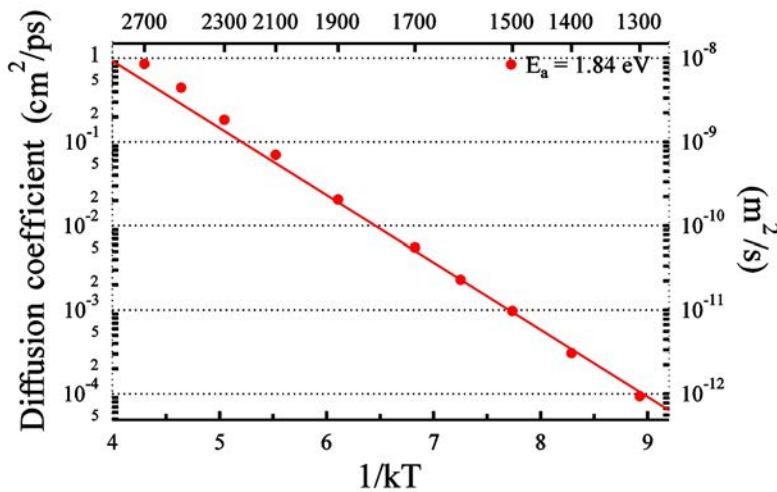

Figure 3.30. Arrhenius fit to the MD simulation points.

Figure 3.30 shows the Arrhenius fit to the MD simulation points. The main results show the diffusion coefficient super-exponential dependence at temperatures above $2/3$ of T_m , seen also in self-diffusion experiments and the effective jump frequency of $\nu_{\text{eff}} = 10^{15}$ Hz, obtained from the Arrhenius fit. This value is noticeably higher than the value of about 10^{13} Hz usually used in the simulations.

Fuel retention, for its part, has been studied by MD and Density Functional Theory (DFT) calculations. The focus has been on high flux and low energy hydrogen irradiation and hydrogen supersaturation. The H concentration in W was noticed to increase rapidly during high flux irradiations because of reduced diffusion. In addition, W vacancies were readily formed during H supersaturation,

which leads to an enhanced fuel retention in W. Considering the formation of vacancies, our simulations show the occurrence of long vacancy jumps at high temperatures. For H concentrations of 20–30 at.%, monovacancies were formed at MD time scales ~ 10 ns at high temperatures. Close to the surface, vacancies were formed already at 500 K.

3.2.9 Arc-discharge cleaning of plasma-facing components

EFDA Task(s): WP13-IPH-A03-P2
Research scientist(s): A. Hakola, J. Likonen, VTT
Collaboration: T. Haikola, J. Kolehmainen, M. Koskinen, S. Tervakangas, DIARC-Technology

In 2013, the work concentrated on analysing Al, Al-W, C-W, and Al-C-W samples (1- μm thick coatings on stainless steel, all doped with H), treated either with the arc-discharge or the Ar^+ plasma-sputtering method. In the arc-discharge experiments, the background Ar pressure, the arc voltage, the cleaning time, and the distance between the anode tip and the sample surface were varied. The resulting surfaces were then investigated using Secondary Ion Mass Spectrometry (SIMS) and Secondary Electron Microscopy (SEM).

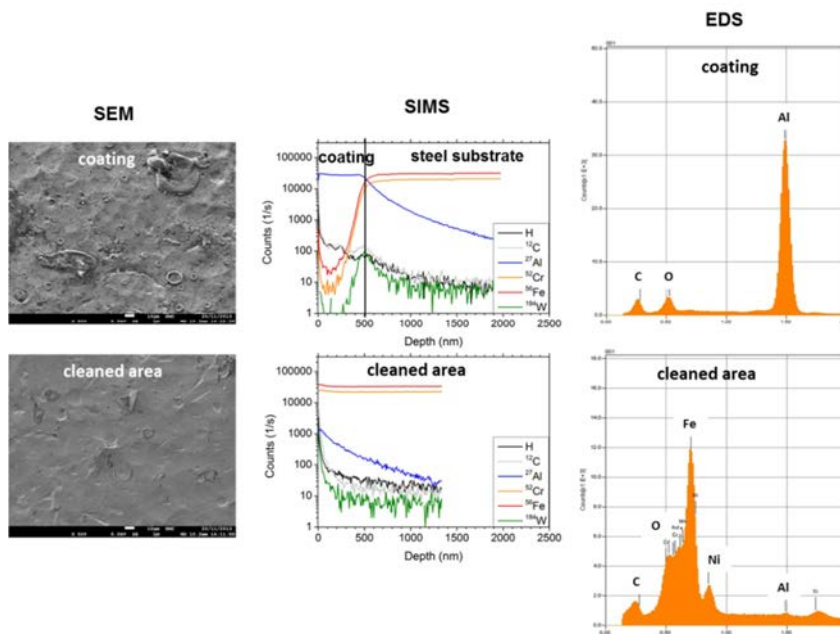

Figure 3.31. SEM, SIMS, and EDS results from the surface of an Al coating (top) and a plasma-cleaned region (bottom).

SIMS profiles indicated that the arc-discharge-treated surfaces were relatively clean but relatively rough and their structure had been severely modified. As a result, part of the removed material had been deposited in valleys between protruding hills on the surface. This was verified by SEM: the cleaned surface showed features with the size of several micrometers. In addition, signs of local melting could be seen and the Energy Dispersive Spectroscopy (EDS) analyses indicated coating material to lie on the recessed areas of the surface. A prominent oxygen peak suggested that the surface had been considerably heated during the cleaning process and oxidized after venting. In any case, the cleaning rate is very high: the entire surface layer can be removed in 1–2 s. The plasma-cleaning experiments, for their part, were relatively slow – the cleaning times ranged from 60 to 120 minutes – but the resulting surfaces were extremely clean and smooth. Only remnants of the original coating material could be measured on the surface and no changes in surface roughness were observed (see Figure 3.31).

3.3 Physics of plasma heating and current drive

3.3.1 Development and tests of ICRH heating module in ASCOT+RFOF

EFDA Task(s): WP13-ITM-IMP5-ACT3-01, WP13-ITM-IMP5-ACT1-03
Research scientist(s): A. Salmi, VTT
Collaboration: T. Johnson, KTH Stockholm

RFOF is an ITM FORTRAN library that implements ICRF physics as a Monte Carlo operator such that it can be called within an orbit following code like ASCOT. Whilst RFOF is still in development phase it will support acceleration techniques which together with ICRH optimised orbit following code will enable very advanced and flexible tool for ICRH modelling. In CPU wise it will be roughly at the same footing as bounce-averaged MC codes such as FIDO or SELFO.

The current tasks are for developing and integrating ASCOT into the RFOF module as well as for verification and validation of the code package. ASCOT/RFOF testing environment on the new gateway was successfully modified to work on the new compiler and the file system. The latest version of the RFOF source was made compatible with the latest ASCOT source. Bugs related to the acceleration scheme of the ICRH interaction were searched and eliminated in collaboration with T. Johnson before, during and after the Helsinki Code Camp. First tests of the improved acceleration functionality, using only a small number of initially thermal Hydrogen ions, now produce the expected results, i.e. same power absorption regardless of the level of acceleration (see Figure 3.32).

The work has now reached a stage where it is possible to use the already implemented parallelisation and optimised particle weighting scheme together with the acceleration to enable large scale simulations in reasonable CPU cost. The next phase will be to run relevant heating schemes with good statistics for the full scale validation and verification tests.

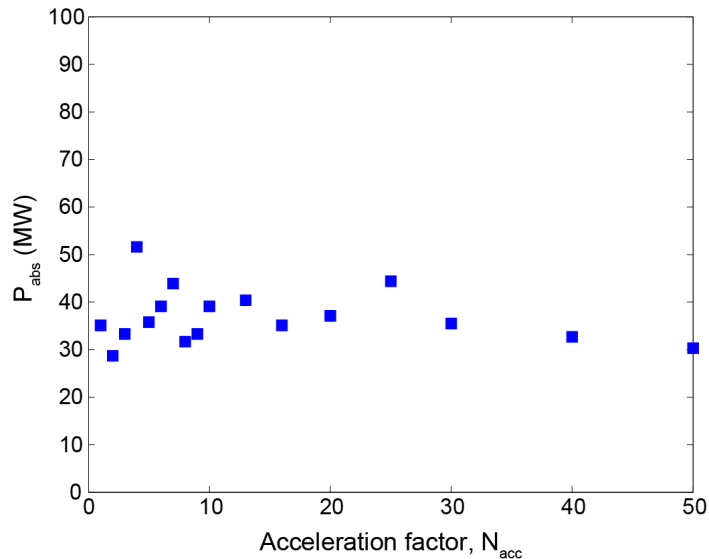

Figure 3.32. Small scale test (large noise expected) with hard coded acceleration with various levels of acceleration shows that now roughly constant amount of RF power is absorbed regardless of the level of acceleration.

3.4 Energetic Particle Physics

3.4.1 Modelling fast ion redistribution and wall loads in the presence of MHD activity

EFDA Task: WP13-IPH-A09-P1-01

Research scientists: A. Snicker, E. Hirvijoki, AU

During the end of the year 2012, ASCOT was updated to include MHD activity for more realistic modeling of fast particle transport. The model has now been used for investigating the redistribution of fusion born alphas in ITER scenarios. The results are presented in publication [A. Snicker et al., Nucl. Fusion **53** (2013) 093028].

The effects of Neoclassical tearing modes (NTMs) were studied in the 15 MA H-mode scenario. An amplitude scan over the NTM magnitude revealed that the alpha particle heat load to the wall structures would stay safely within the design limits. Alfvén Eigenmodes in the 9 MA hybrid scenario were, however, observed to cause possibly significant redistribution. See Figure 3.33 where both the relative spatial and velocity space redistribution are illustrated. Self-consistent simulations would be needed to thoroughly investigate whether the observed reduction of alpha heating could lead to changes in the equilibrium.

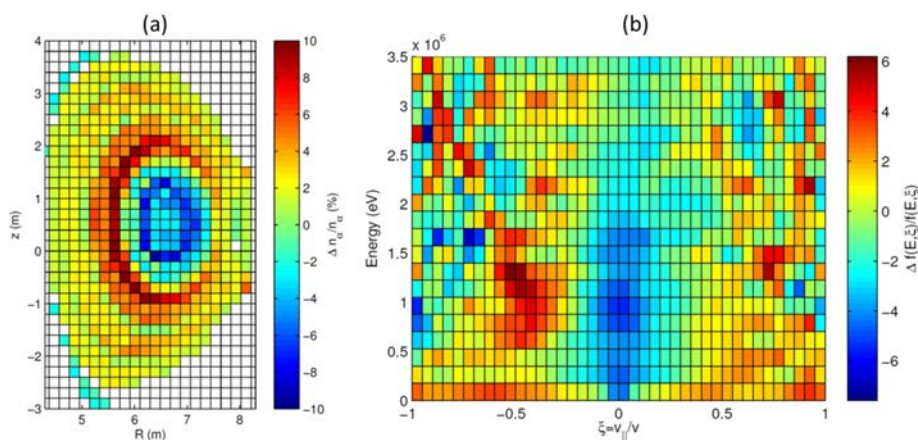

Figure 3.33. (a) Relative spatial redistribution and (b) relative velocity space redistribution of fusion-born alphas due to Alfvén Eigenmodes in the ITER 9 MA hybrid scenario.

3.4.2 Simulating escaping fast ion loss diagnostics in ASDEX Upgrade

EFDA Task(s):	WP13-IPH-A09-P2-01
Research scientist(s):	S. Äkäslompolo, AU
Collaboration:	G. Bonheure, ERM-KMS M. García-Muñoz, Seville University G. Tardini, IPP Garching

ASCOT code was used to model the fusion product activation probe experiment in ASDEX Upgrade. The activation probe utilizes the low level radioactivity induced by transmutation of material samples irradiated by fusion reaction products. The discharge was forward modeled with ASCOT: Millions of test particles representing various D-D fusion products were launched from the entire plasma volume. The particles were weighted with the local fusion reactivity. The flux to the activation probe (mounted on a manipulator at the outer midplane) was calculated (Figure 3.34) and compared to the experimental value. It was discovered that the probe orientation was suboptimal. Most of the fusion products hit the probe are filtered by the graphite cap. Therefore, reverse modeling (launching the test particles from the probe, backwards in time) will be needed for completion of this study.

Also the analysis of FILD probe simulations started in 2012 was continued. The simulations are part of the ITPA-EP joint experiments.

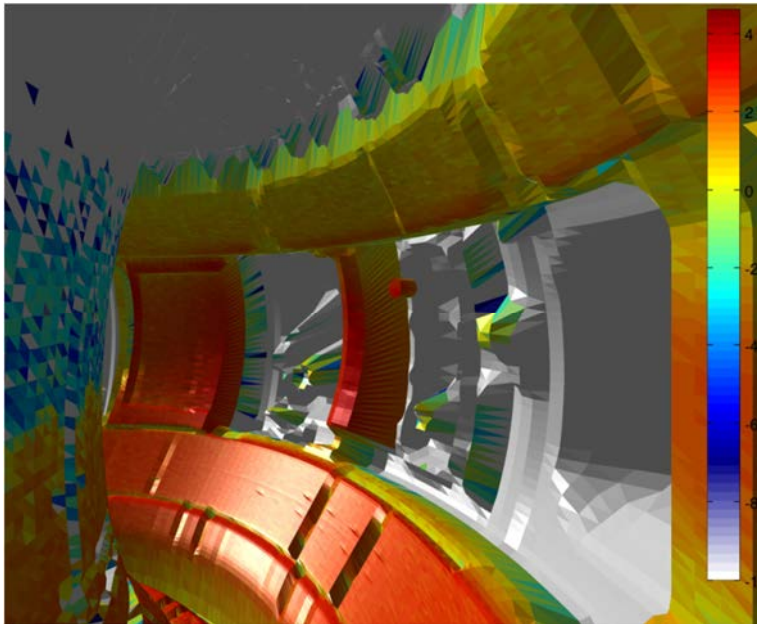

Figure 3.34. Distribution of fusion products on AUG wall.

3.5 Theory and Modelling for ITER and DEMO

3.5.1 SimITER 2010–2013

2013 was the final year of the four-year SimITER project funded by the Academy of Finland under the Research Programme for Computational Sciences (LASTU). Within this project, the consortium of AU, UH, ÅA, VTT and CSC made significant progress in improving the computational efficiency of ASCOT, ERO and PARCAS by implementing modern optimization and programming practices (e.g. GPGPU) and novel multi-scale modelling methods. On the physics side, methodology was developed for accurate 3D magnetic field and first wall modelling, being vital for realistic fast ion calculations for ITER. Recent theory work for a more complete physics basis of guiding-centre following codes include a proper diffusion operator for anomalous transport, rotating MHD modes in real tokamak geometry, NBCD model for ITER and a guiding-center-consistent Coulomb collision operator. Atomistic-level plasma-wall interaction modelling explained the mechanisms of molecular sputtering of beryllium and tungsten fuzz formation as well as produced new Be/W/C data for the macroscopic impurity migration code ERO to account for material mixing and potential chemical effects. Gyrokinetic modelling with the Elmfire code was extended towards the first wall by implementing toroidal limiters.

3.5.2 ITER 3D wall from CAD data

EFDA Task(s): WP13-ITM-EDRG-ACT1-01, WP13-ITM-EDRG-ACT1-02
Research scientist(s): J. Miettunen, S. Äkäslompolo, AU

For accurate simulations of fast ion power loads and migration of impurities in ITER, a realistic 3D geometry of the tokamak first wall is needed. With the method developed at Aalto University, it is possible to use computer-aided design (CAD) data of a tokamak as an input for creating the wall geometry for simulations. First, ray-tracing on the CAD data is performed to find the plasma-facing surfaces after which the output is defeatured. See also related work in Section 5.4 on calculating the magnetization of ferromagnetic ITER components.

The CAD data describing ITER was received from F4E in STL form. A dense set of rays suitable for the ITER geometry was created and ray-tracing was performed using a code developed for the purpose. To account for numerical inaccuracy and excessive detail, defeaturing was done by fitting a smoothing spline to the output in Matlab. The resulting 3D wall geometry (see Figure 3.35) can be used for simulations with, e.g., the orbit-following code ASCOT. Future work will include transferring the wall geometry for use within the ITM framework.

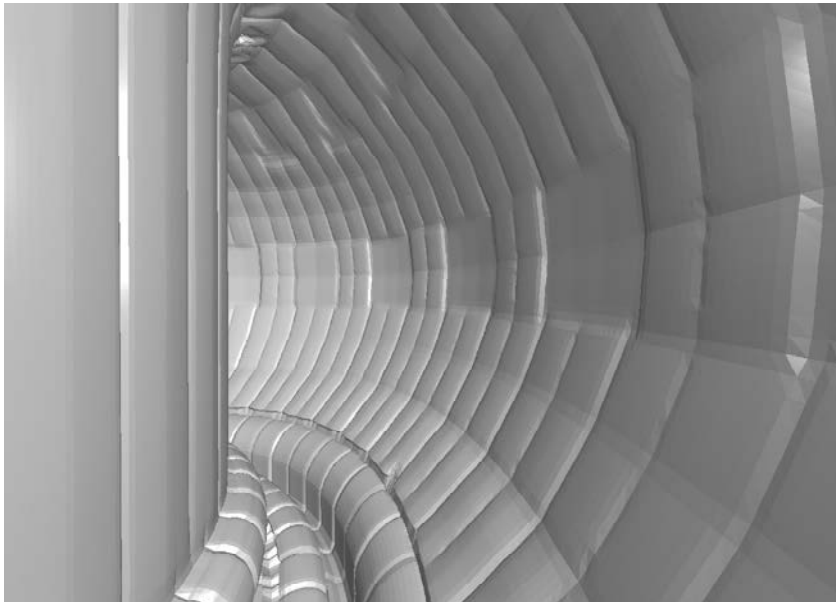

Figure 3.35. A view of the 3D wall geometry of ITER created based on CAD data.

3.5.3 Reconstructing 3D plasma equilibrium with ELMER

Framework: SimITER Consortium
Research scientists: S. Äkäslompolo, T. Kurki-Suonio, AU
S. Ilvonen, P. Råback, J. Tarus, CSC

The conventional solvers for the tokamak equilibrium are inherently 2-dimensional, i.e., they assume perfect toroidal symmetry. However, with the devices getting bigger and more complex, this approximation is frequently violated, with plasma exhibiting noticeable toroidal structure.

Currently there exist only a couple of 3D equilibrium solvers in the world, capable of constructing solutions with magnetic islands and ergodic regions. Furthermore, the numerical methods used in these solvers are poorly suited for the task. Constructing an improved 3D equilibrium solver based on the FEM method would not only benefit the fusion community but would open up a new field for the strong Finnish FEM community. Therefore the FEM solver ELMER, developed at CSC, has been tried out as a joint effort between the ASCOT and ELMER groups at Aalto University and CSC, respectively.

An iterative approach was selected to solve the shapes of the plasma surfaces in a case of disturbed vacuum magnetic field. During the solution phase it is expected that the pressure of the plasma as a function of the toroidal flux function does not change. This plasma pressure, together with the initial 2D poloidal plasma shape is obtained using Grad-Shafranov equation and toroidally symmetric average vacuum magnetic field. During solution phase the averaged external magnetic field is replaced with the locally disturbed 3D field and the shape of the plasma is sought using Picard-type iteration.

The test simulations for ASDEX Upgrade tokamak converge, with promising results. Further testing and validation will take place in 2014.

3.5.4 Modelling of material mixing for extrapolation to ITER conditions

EFDA Task(s): WP13-IPH-A01-P1
Research scientist(s): A. Lasa, A. Sand, K. Nordlund, UH
M. Airila, VTT
Collaboration: A. Kirschner, D. Borodin, FZ Jülich
SimITER Consortium

The recently upgraded ITER-Like Wall at JET, as ITER itself, chose tungsten (W) and beryllium (Be) as the first wall plasma-facing materials. Due to the plasma-wall interactions, these materials will erode, be transported, re-deposit and mix. We carried out the first computational, atomistic, systematic study on the W-Be material mixing under fusion-relevant conditions. To this end, W surfaces were irradiated by Be, varying the impacting energy and angle, followed by annealing the mixed W-Be layers. At low energies, a Be layer is deposited on W, suppress-

ing the W erosion. The materials mix as the W atoms are dragged towards the Be layer due to the heat of mixing. Be₂ and BeW molecules eroded, both physically (dimer sputtering) and chemically (sputter etching). All the mixed layers show an underlying HCP-like Be structure and the Be:W ratios are close to those in the intermetallic phases. However, no crystalline alloy structure formed, even after annealing. Further, we developed a geometrical model for the angular dependence of the Be reflection, which strongly affects the W sputtering.

Due to specific data needs in impurity migration modelling of JET ILW discharges, an additional effort was launched to generate sputtering and reflection data on Be impacts on W targets. To this end, the MD code PARCAS was run to generate an 8 x 6 (energy x angle) data matrix with good statistics. The data will be implemented in the ERO code.

3.5.5 Theoretical work on Coulomb collision models

In November 2012, E. Hirvijoki and A. Snicker had visited Alain Brizard in Vermont USA. The main result of this journey was a discovery of a discrepancy in the Coulomb collision Monte Carlo operators that were used for example in ASCOT. Collaboration with Brizard provided means to derive a proper operator that treats both sides of the kinetic Boltzmann equation by the book.

In publication [E. Hirvijoki et al., Phys. Plasmas **20** (2013) 092505], details of the new operator are presented for the first time. Now both the Hamiltonian and collisional motion for a guiding center are derived applying Lie-transform perturbation theory consistently. The new operator will also be implemented in ASCOT4.

3.6 Code Development and Integration

3.6.1 Shielding factor model for current drive studies with ASCOT code

Research scientist(s): A. Snicker, H. Ylitie, O. Asunta, AU

In order to accurately simulate the neutral beam current drive (NBCD) in ITER, a model for shielding factor needs to be applied. The beam ions carry a positive current which is shielded by the negative electron current. To take into account this in guiding center orbit-following ASCOT, see publication [E. Hirvijoki et al., ASCOT: solving the kinetic equation of minority particle species in tokamak plasmas, Computer Phys. Comm., accepted], background research was done in order to select the most updated shielding factor model valid for ITER parameters.

The model in publication [O. Sauter et al., Phys. Plasmas **6** (1999) 2834] was selected and implemented in the ASCOT code. In the implementation, a few additional quantities, e.g. electron trapped fraction, needed to be calculated internally. All subsets were tested carefully after the implementation. Finally also the total shielding factor was compared against similar models used by other codes.

Furthermore, the model is currently used for calculation of alpha particle driven current, and within this study the current shielding factor was compared against the SPOT code, see publication [M. Schneider et al., Plasma Phys. Control. Fusion **47** (2005) 2087]. The resulting shielding factors are in good agreement (Figure 3.36).

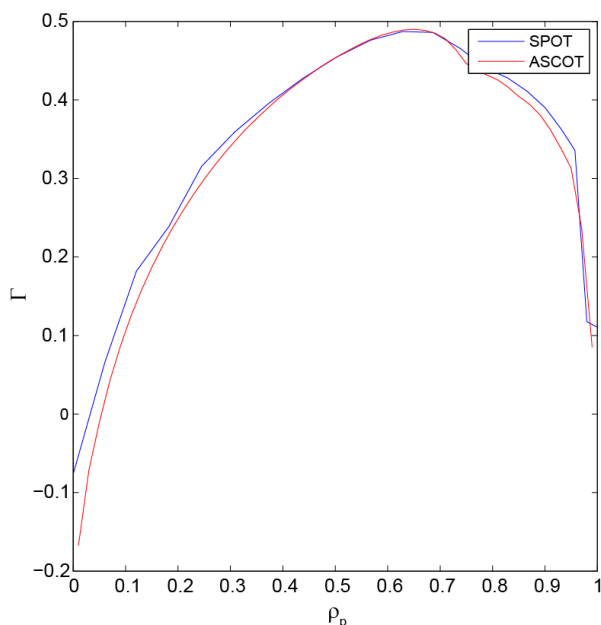

Figure 3.36. Shielding factors calculated using ASCOT and SPOT.

3.6.2 Fusion product source for ASCOT

EFDA Task(s): WP13-ITM-IMP5-ACT4-01;

WP13-ITM-IMP5-ACT1-04;

WP13-ITM-IMP5-ACT2-01

Research scientist(s): S. Äkäslompolo, O. Asunta, E. Hirvijoki, T. Koskela,
A. Snicker, AU

AFSI Fusion Source Integrator is part of the ASCOT suite of codes. It calculates the fusion rates from known plasma parameters or non-maxwellian fast ion density distributions. Components of AFSI are usable in integrated modelling tools, such as the EFDA-ITM heating and current drive work flow and JINTRAC.

In 2013 the main new features are: efficient calculation of thermal fusion rates by evaluating precalculated rates, including the energy distribution of thermal fusion products and improved integration of beam-target fusion rates.

3.6.3 Checkpoint system for ASCOT

Research scientist(s): Tomi Kiviniemi, S. Äkäslompolo, AU

ASCOT is a highly parallel research code designed to be run in parallel on thousands of CPUs in a supercomputer. The typical runtimes are hours, usually up to a day. However, ASCOT was missing the capability to check intermediate results and abort the run in case of errors to avoid squandering resources.

The newest version of ASCOT now supports writing the intermediate results to disk. This means ASCOT can continue an interrupted simulation. The typical reasons for interruptions are hardware faults and underestimated run time limits.

3.6.4 Gyrokinetic global SOL/edge code development

Framework: SimITER Consortium

Research scientist(s): T. Korpilo, AU
J. Heikkinen, VTT

Collaboration: J. Westerholm, A. Signell, Åbo Akademi University

Memory consumption and (MPI) communication cost of the Poisson matrix are the main computational bottlenecks, even with the 1D domain decomposition in use, in the way of simulating middle and large size tokamak plasmas such as JET plasmas with the present ELMFIRE code. Within the CRESTA EU framework the Åbo Akademi scientists have continued the project of implementing the 3D domain decomposition into the ELMFIRE code in order to remove these bottlenecks.

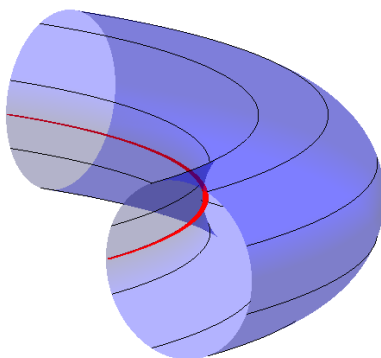

Figure 3.37. Toroidal limiter configuration: poloidally infinitely thin toroidally continuous plate (red) protrude from the wall (blue).

The implementation work turned out to be time-consuming, and therefore first results are expected later in 2014. Otherwise the code performance has been improved by smart vectorization and by moving the ELMFIRE Fortran source code

fully to Fortran 90. The global feature of the code has been improved by a toroidal limiter (Figure 3.37), which impose a natural boundary condition for tokamak plasma simulations. The limiter adds a scrape-off-layer region with separatrix to ELMFIRE simulations, thus allowing coupled core-edge simulations. The first results demonstrate that the scrape-off-layer region can be introduced to the Poisson solution in the global gyrokinetic particle-in-cell simulation.

3.6.5 Benchmarking of SOL turbulence code

EFDA Task(s): WP13-ITM-IMP4-ACT1
Research scientist(s): S. Janhunen, AU
J. Heikkinen, VTT
Collaboration: J. Westerholm, A. Signell, Åbo Akademi University

ELMFIRE global 5D gyrokinetic code has been extended to the SOL region where it can predict parallel flows, temperature, potential, and density as well as fluctuations as a function of parallel or poloidal coordinates in the presence of limiter. This capability was not yet achieved in divertor SOL plasma.

3.6.6 First principle based core/edge transport simulations using HPC resources

EFDA Task(s): WP13-ITM-IMP4-ACT1
Research scientist(s): S. Janhunen, T. Korpilo, AU
J. Heikkinen, VTT

The proposed project applied the Elmfire in the TF-ITM IMP#4 benchmark project with given data on the ITM Gateway as IMP4 benchmark case (machine imp4, shot 1, run 1 in the ~bscott database). The case was only given as a set of CPO's that were read in from the IMP4Init file, which was interpreted to Elmfire using L3 and cubic spline interpolants (q was inverted to get the right current, not the other way around which gave a wrong q). No heating was applied. Some description of the case can be seen at <http://www.ipp.mpg.de/~bds/cyclone/>. It was electron kinetic, we ran tests with it and found that during the simulation momentum conservation was mildly broken, and there was a simultaneous crash of fluxes in the middle of the simulation region. With this experience and found improvements in the code, the ELMFIRE code was applied in specific verification runs in TEXTOR and FT-2 experiments.

3.6.7 Code validation and performance scaling

EFDA Task(s):	WP13-ITM-IMP4-ACT1
Research scientist(s):	T. Korpilo, T. Kiviniemi, AU J. Heikkinen, VTT
Collaboration:	J. Westerholm, A. Signell, Åbo Akademi University

While the 3D domain decomposition to ELMFIRE is under construction, the memory usage of the Poisson matrix is optimized by flexible radial and poloidal grid resolutions. The grid resolution of the order of average ion gyroradius throughout the simulated plasma minimizes the number of zero Poisson matrix entries in the CPU memory, and thus provides the most efficient memory scaling in terms of tokamak size and plasma temperature.

The ELMFIRE results of parameter scan over TEXTOR parameters showed radial propagation velocity of GAMs with similar decrease as a function of temperature as in recent experiments. The radial wave lengths of GAMs show good agreement with analytic theory of Itoh et al. The code has also been shown to reproduce results of analytic estimates for parallel plasma conductivity and bootstrap current with a reasonably good agreement varying the temperature and impurity content of the plasma.

3.6.8 High performance computing / OpenMP and GPGPU in ASCOT

Framework:	SimITER Consortium
Research Scientists:	S. Äkäslompolo, T. Kurki-Suonio, T. Kiviniemi, T. Korpilo, S. Janhunen, S. Leerink, AU J. Heikkinen, VTT J. Westerholm, E. Yurtesen, Åbo Akademi University

The Biot-Savart law integrator software BioSaw was used as a test case for exploring the possibility of using openMP in ASCOT. Additionally, the key components of BioSaw were reimplemented using the C language to utilize GP-GPU hardware. An excellent speedup was achieved.

3.6.9 Development of Kepler workflows for integrated modelling

EFDA Task:	WP13-ITM-IMP3-ACT2
Research scientist:	M. Airila, VTT
Collaboration:	D. Borodin, FZ Jülich D. Coster, H.-J. Klingshirn, IPP Garching R. Coelho, IST Lisbon

The 3D plasma-wall interaction and impurity transport code ERO needs the following interface routines for CPO input/output:

- Pre-processor edge CPO → ERO
- Post-processor ERO → edge CPO
- Post-processor ERO → wall CPO
- (Post-processor wall CPO → ERO is presently not relevant as no suitable data is available in wall CPO's.)

The edge CPO interface routines were previously implemented in dataversion 4.09a; therefore the ERO/ITM 2013 activities focused on edge and wall CPO compatibility in dataversion 4.10a. In addition, automatic wall geometry generation from the fluid grid for ERO was implemented as a new feature. The new wall CPO interface routine stores the wall geometry as “wall2d” and “wall3d”, surface densities (x,y) of modelled atomic species in the surface layer, plasma flux (x,y), average energy of plasma particles (x,y) and surface temperature (x,y).

Conversion of necessary data in edge CPO's into ERO-readable format was completed (fluid plasma quantities needed as plasma background in ERO and wall geometry information contained in 2D grids). The upgrade of edge CPO I/O routines into dataversion 4.10a was partially completed (see below). The implementation of an output routine to wall CPO has been partially completed (see below).

For compatibility with SOLPS-generated edge CPO's, the input routine for edge CPO data supports only the temporary solution where the B field components are stored as `te_aniso`. This must be changed when SOLPS starts using the edge CPO the regular way. The output routine for wall CPO is still under work (expected completion in December 2013; the work was slightly delayed as a bugfix in the Grid Service Library was needed. The `itmaggd` development version 1.3 (25/11/2013) contains the fix.).

3.6.10 ASCOT-BBNBI in EFDA-ITM framework

EFDA Task(s):	WP13-ITM-IMP5-ACT1-01, WP13-ITM-IMP5-ACT1-02, WP13-ITM-IMP5-ACT2-01
Research scientist(s):	O. Asunta, S. Sipilä, A. Snicker, S. Äkäslompolo, AU
Collaboration:	T. Johnson, KTH M. Schneider, CEA

Neutral beam injection (NBI) heating is extensively used in present-day tokamaks. NBI will also be one of the main heating schemes as well as a significant source of non-inductive current drive in ITER. Therefore, there has been a strong interest from the EFDA Integrated Tokamak Modelling Taskforce (ITM-TF) to have the Monte Carlo beam ionization code BBNBI and the particle following code ASCOT included as actors in the IMP5HCD workflow that provides the information on plasma heating and current drive to the European Transport Solver (ETS). Later on, ASCOT will also be used for simulating other fast ions such as fusion-born alpha particles and ion cyclotron resonance heated particles.

During 2013, BBNBI and ASCOT were ported to the latest version of the ITM datastructures. BBNBI has been tested extensively both as a stand-alone actor and as a part of the IMP5HCD workflow. The tests were performed for JET, ITER, and most recently DEMO1. While comprehensive benchmarking of BBNBI in the Kepler environment against other codes will be performed in 2014 alongside the fast ion slowing down code benchmark, the results of a preliminary comparison between BBNBI and NEMO look very promising.

As for ASCOT, both ASCOT4 and an earlier version ASCOT3.5 have been successfully run in parallel in the Kepler environment. This is an important milestone because parallel processing is necessary in order to obtaining statistically meaningful results in a reasonable amount of time. ASCOT4 was also run as part of IMP5HCD, but more testing and benchmarking against other codes is needed before the actor can be released for public use.

3.7 Plasma Diagnostics

3.7.1 Operator support for JET neutron diagnostics during maintenance

EFDA Tasks:	JW12-OEP-TEKE-27; JW13-OEP-TEKE-32
Research scientist:	M. Santala, AU
Collaboration:	EFDA JET

The main activity during JET shutdown was the JET neutron calibration exercise which took place in April 2013. A powerful ^{252}Cf source held at the tip of an aluminium baton was taken into the machine by JET remote handling team and the neutron measurements were taken at about 200 different locations by the fission chambers and the neutron activation system. Overall the calibration exercise took many months of planning, two weeks for execution in two shifts from 6am to 1am, and months for analysing and interpreting the results.

This exercise was only second such absolute neutron calibration at JET, with the previous one having been done in 1980's. Overall, the results were consistent, however, detailed understanding of fine details has been challenging. For instance, accurate calibration of HPGe detectors used for counting the neutron activation samples has required much work. Due to the limited activity of the source and the consequent low count rates, a close counting geometry was used which has been difficult to analyse. For the fission chambers, detailed modelling of JET environment is utmostly important for interpretation of the results.

3.7.2 Operator support for JET NPA(s) during campaigns

EFDA Tasks: JW12-OEP-TEKE-27; JW13-OEP-TEKE-32
Research scientist: M. Santala, AU
Collaboration: EFDA JET
E. Lerche, D. Van Eester, DIFFER

Both JET NPAs were operational during the 2013 campaigns. However, this activity was cut short due to difficulties with machine operations (Oct8 NBI troubles and broken reciprocating probe) which eventually required emergency manned access into the machine. There still is strong emphasis to limit the formation of fast ion tails in plasmas so the high energy NPA was not fully utilised. The low-energy NPA, on the other hand was requested by several experiments.

The main use for the high energy NPA was to confirm that a powerful ion tail is not created rather than to monitor such a tail in detail. This was often used in conjunction with low energy NPA to measure accelerated tails at lower energies. A large user in this scheme was experiment for optimisation RF heating without the generation of strong tails. Another important user of the low-energy NPA was the RF wall conditioning study, where low energy NPA is the only diagnostic capable of making direct measurements of the RF accelerated ions.

3.7.3 Plan for low energy NPA maintenance and upgrade

EFDA Task(s): JW12-PM-EDT-ISU
Research scientist(s): M. Santala, AU
Collaboration: P. Beaumont, CCFE
N. Dzysiuk, Uppsala University

This task includes several activities for future activities of the JET low energy NPA. First it includes a general plan for maintenance of the diagnostic during the following shutdown in order to make it compatible with DT campaign and ensure operational reliability, second a plan for upgrading the existing scintillator detectors to silicon detectors has been prepared, and third, MCNP simulations have been carried out by VR to assess the radiation environment at the diagnostic within its shield. Furthermore, an impact assessment was carried out for contemplated relocation of the diagnostic to port at Oct 8 adjacent to NBI injector.

The main activity in the maintenance plan is the study and rectification of the breakdowns at the NPA accelerator stage. Video inspection has already been carried out which has helped to narrow down the location of breakdown. Furthermore, several relatively minor activities are planned like replacing single windows with double windows for T compatibility and a modernisation for turbopumps. The upgrade study proposes making a new batch of silicon detectors for the NPA and using a RAL designed readout chip for readout. It is planned to use FPGA at torus hall for interfacing to the readout chips and data transmission to J1T. Transmission of data is envisaged over Ethernet, tentatively using 100/1000 Mbit/s copper connection. At the receiving end ordinary PC computer equipment can be used. The modelling of radiation environment suggests that the existing radiation shield will be adequate also for DT operations.

The relocation study concluded that the relocation is not feasible. First, the line of sight would intersect the neutral beam heating, and even minuscule backscatter into NPA could ruin the measurements or possibly even damage the instrument, particularly during operational difficulties. Second, the environment at Oct8 would be much more exposed to radiation from plasma, especially during DT operations, and much improved shielding would be necessary.

3.8 Power Plant Physics & Technology

3.8.1 Power plant power exhaust studies

EFDA Task(s):	EFDA Fellowship
Research scientist(s):	L. Aho-Mantila, VTT
Collaboration:	D. Coster, M. Wischmeier, IPP Garching S. Brezinsek, FZ Jülich

Power exhaust predictions for DEMO require credible models of the plasma edge, including the scrape-off layer and divertor plasmas in which interaction with the material surfaces takes place. The first phase of power plant power exhaust studies focuses on validating the assumptions used in plasma edge modelling against present-day experiments. These studies aim at building a database of carefully documented plasma experiments and validated simulations, based on which extrapolations to DEMO will be made.

In 2013, extensive scans of the edge plasma properties with different levels of power dissipation by radiating impurities were performed using the SOLPS5.0 code package. The modelled parametric dependencies were compared to experimental trends in N-seeded discharges, carried out in 2012 in the full-metal devices ASDEX Upgrade and JET. According to both simulation and experimental results, divertor radiation levels of around 60% of the plasma input power can be achieved in devices of various sizes by the use of N seeding. At higher radiation levels, part of the radiation takes place in the core plasma which, depending on the detailed plasma conditions, may lead to degradation of the confined plasma conditions or even plasma disruptions. A DEMO reactor will require plasma radiation levels above 90% of the exhaust power, which requires careful optimization of the impurity seeding.

The simulations predict the major changes in edge plasma properties with N-seeding rather well, capturing for example the different stages in the evolution of the radiation pattern in the divertor. The largest problems are observed when comparing the code predictions regarding the behaviour of the fuel species against the experimental measurements, particularly at high plasma density levels. The discrepancies appear not to be related to the radiative properties of the impurities, and can be considered as more fundamental issues in the code predictions. The first extrapolations of impurity-specific effects are expected in 2014.

3.8.2 Modelling of radiation effects in FeCr, tungsten and tungsten alloys

EFDA Tasks: WP13-MAT-IREMEV-01; WP13-MAT-IREMEV-04
Research scientists: T. Ahlgren, F. Granberg, K. Heinola, A. Lasa, K. Nordlund, A. Sand, UH

3.8.2.1 Radiation effects in FeCr

The main candidates for the blanket material in DEMO and future commercial fusion power plants are high-chromium ferritic-martensitic (F/M) steels, due to their superior radiation hardness compared to more conventional austenitic steels. These steels are expected to be exposed to intense neutron-irradiation fields, with the result that many of their properties will change, sometimes significantly, with time. In particular, they will undergo hardening and/or embrittlement at low temperature (~300°C) and will be affected by irradiation creep at higher temperature (up to the limit of ~550°C). The extent to which these changes will occur is known to depend on the changes induced by neutron irradiation at the atomic and nanometric scale. These include not only the creation and evolution of defects of vacancy or interstitial type (voids, dislocation loop etc.), but also microchemical changes, like precipitation of new phases and segregation at extended defects, e.g. grain boundaries. The kinetics of these processes is strongly influenced by the chemical composition of the material. Therefore, whether or not a given steel shows resistance to swelling, or is more or less prone to embrittlement, depends eventually also on its chemical composition. For a conscious and safe choice of the composition of these steels for nuclear applications, it is thus important to reach a sufficient level of understanding of the effect that specific impurity precipitates and alloying elements have on their behaviour under irradiation.

We have previously, in close collaboration with SCK-CEN, examined in detail the effects of Cr on damage production and dislocation loop mobility in these steels. We found, as a general overview, that Cr has only a small effect on primary damage production, but on the other hand a major slowing down effect on dislocation loop mobility, an effect that is now recognized as a likely reason to the reduced swelling in F/M steels. However, there are many other physical phenomena that may affect microstructure evolution. One of these, which until now has not at all been considered on the fundamental level, is the effect of carbide precipitates

on the mobility. In particular, either iron carbide (cementite) or chromium carbide precipitates may be present in F/M steels. As a first step to address this issue, we have (utilizing our recently finalized Fe-Cr-C ternary interatomic potential) started to examine the effects of carbide precipitates on the mobility of dislocations in steels.

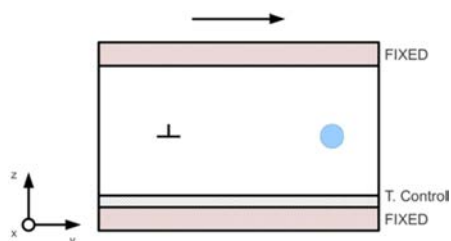

Figure 3.38. Simulation setup for dislocation reactions with a carbide precipitate. The edge dislocation is inset in the simulation cell at the position indicated by the inverse T symbol, and the cell is shorn such that the dislocation will interact with a carbide precipitate. Since periodic boundaries are used, the dislocation may interact with the precipitate several times.

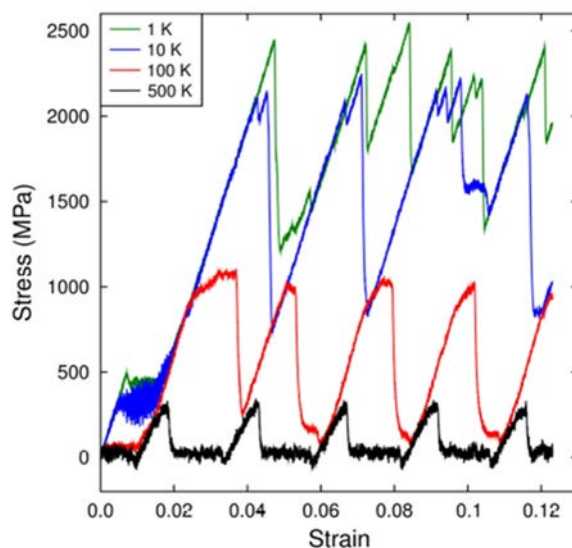

Figure 3.39. Stress-strain behaviour for the edge dislocation interaction with a 2 nm carbide precipitate. Each peak corresponds to a dislocation position where it is pinned by the obstacle, and the repetition is due to the same dislocation passing through the simulation cell boundaries and re-interacting with the same obstacle. Note, however, that the peaks are not identical in stress level, showing that there are some modifications to the obstacle due to each passage. The results also show that there is a strong temperature dependence on the strength of the obstacle: at higher temperatures the dislocation can pass the precipitate at an order of magnitude smaller stress levels, due to thermal activation.

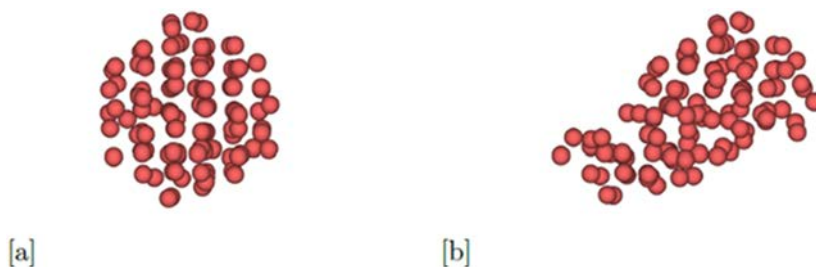

Figure 3.40. A 2 nm carbide precipitate (a) before and (b) after the simulation at 10 K. Only the carbon atoms are shown for clarity.

Our results, illustrated in Figure 3.38–Figure 3.40, show that the used potential gives significantly higher critical stresses to initiate dislocation movement at low temperatures. The results show that an edge dislocation can penetrate cementite precipitates of sizes 1 nm and 2 nm at temperatures as low as 1 K. The 4 nm precipitate is not sheared by the edge dislocation at low temperatures (100 K).

3.8.2.2 High energy collision cascades in tungsten

Recent experiments have revealed unusual features of cascade damage associated with high-energy ion impacts in tungsten (W). High-energy 150 keV cascades initiated by self-ions in W, corresponding as a good experimental approximation to the effects of fusion neutrons on W divertors, were found to produce a high fraction of the 100 self-interstitial and vacancy type dislocation loops, contradicting the current understanding of dislocation loop formation, according to which only the $\frac{1}{2}$ 111 type loops should form in tungsten because of its elastic isotropy.

Molecular dynamics (MD) simulations are capable of describing both the heat spike and the recombination of damage, which lead to dislocation loop production. Cascade damage in other materials, for example iron, has been extensively studied by MD methods. In particular, it has been shown that at high impact energies cascades split into separate subcascades, resulting in defect production scaling linearly with the impact energy. For iron this occurs at energies of the order of tens of keV. However, in tungsten, collision cascades have previously been studied by MD methods for energies only up to 50 keV, whereas the average energy of primary recoils from 14 MeV fusion neutrons is close to 150 keV.

We have recently carried out and analyzed MD simulations of 150 keV collision cascades in bulk W, comparing different inter-atomic potentials. We investigate the development of the cascades, and study the effects of energy losses and the choice of primary recoil direction on the final damage, comparing simulations with observations.

The results showed that vacancy clusters formed mostly as low density areas at the center of what had been the liquid area. The probability of cascade collapse was found to be affected by the rate of cooling of the heat spike, with slower cool-

ing increasing the probability of collapse. We also found a dependence on the interatomic potential and way to treat the lowest-energy electronic stopping, showing that more work is needed on the fundamental aspects of both interatomic potentials and low-energy electronic stopping. Most significantly, we did find with one interatomic potential that one cascade collapsed into a vacancy loop with Burgers vector $b = 100$, see Figure 3.41.

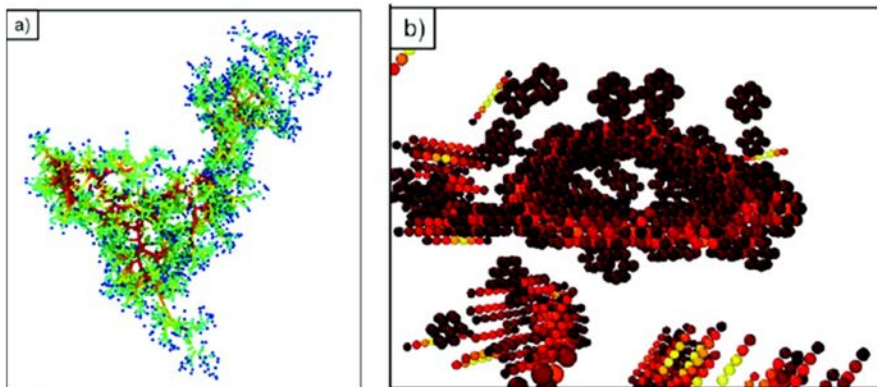

Figure 3.41. (a) Paths of energetic ions (> 10 eV) during the initial development of a 150 keV cascade in W. The color scale indicates the time, starting with red at 0 fs and ending with blue at 200 fs. (b) Final configuration from a cascade simulation resulting in cascade collapse, showing a large dislocation loop with Burgers vector $b = 100$. Atoms are colored according to their potential energy, with lighter color representing higher energy.

3.8.3 Remote handling studies for DEMO

EFDA Task(s): WP13-DAS07-T05; WP13-DAS07-T06
Research scientist(s): M. Siuko, J. Järvenpää, D. Carfora, VTT
Collaboration: J. Harman, EFDA CSU Garching
O. Croft, CCFE

The objective of the WP13-DAS07-T06 activities was to develop Remote Maintenance concepts for replacing divertor cassettes and cooling pipes in DEMO. One of the purposes of DEMO is to show power-plant-level reliability and availability, and they are greatly affected by the efficiency of the maintenance operations in the reactor. Particularly, the availability can be improved by avoiding complex operations in the vessel and reducing the complexity of the design of the reactor components.

When developing divertor maintenance for DEMO, the divertor replacement procedure of ITER can be used as a starting point. However, the working condi-

tions in DEMO will be harsher and the reactor design will be different. In this task, the following aspects were addressed:

- Divertor RH design considering also the blanket and blanket handling
- Conceptual design of the telescopic radial transporter and its support
- Conceptual design of the end-effector for central, left and right cassette
- Plan for the divertor service pipe replacement operations
- Consider the proposed Blanket remote handling equipment
- Pre-conceptual study of the cassette locking methods.

The reactor design of DEMO is proposed to have 16 toroidal field coils. Between each coil is a port, which makes totally 16 ports. It is assumed that each port can be used to access the reactor for divertor maintenance.

By designing the divertor to consist of 48 cassettes, it makes 3 cassettes per each of the 16 ports. Through each port, a cassette straight to the port and one at left and one at right can be handled. By this arrangement, there is no need for separate in-vessel cassette carrier. When comparing to ITER, much simpler maintenance procedure and logistics can be achieved. The divertor ports are inclined 45 degrees downwards (see Figure 3.42). Due to the inclination and the cassette load, ITER-like rack-and-pinion drive might not be suitable for the mover. Therefore, a conceptual telescopic radial mover has been designed and proposed. The two systems will be analysed in order to find advantages and disadvantages of the solutions. However, ITER second cassette end-effector can be used as an example when developing an end-effector to handle the three DEMO cassettes through one port. Each of the divertor cassettes is estimated to weigh 14 tons.

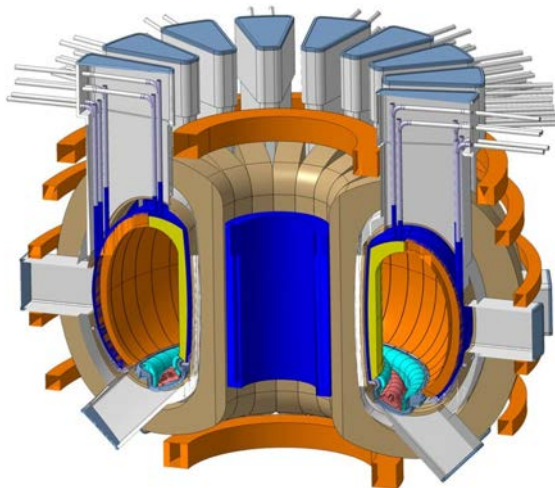

Figure 3.42. The divertor ports are inclined by 45 degrees. The divertor replacement is done through the ports. The blanket replacement is done through the upper vertical ports.

The mover is operated from the transportation cask. Due to the inclination of the tunnel and therefore high forces, high loads need to be considered in the cask docking system. The lower end of the radial tunnel has a docking interface for the transportation cask. The interface is quite high and inclined, which provides quite a complicated interface for the cask to be aligned (see Figure 3.43).

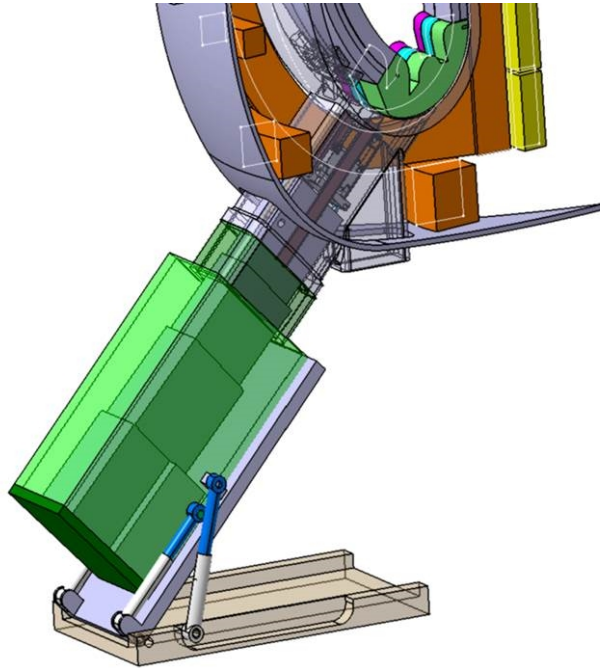

Figure 3.43. Short reactor ports lead to complicated transporter solutions.

The cassette-reactor connection has to support the high magnetic forces of DEMO in all directions and to provide simple, robust operation. As in ITER, the cassette preloading is necessary to remove clearance from the locking system which could cause the cassette to shake under magnetic fields. The cassette outboard locking mechanism has to be designed to generate the preloading with a simple mechanism. The design proposal is still under work. The aim is to find a simple solution which can be disconnected with RH tools and rescued by force if necessary.

Each of the cassettes is equipped with two cooling fluid pipes, inlet and outlet. The outer diameter is 125 mm and the wall thickness 15 mm (Figure 3.43). The most suitable arrangement is that the pipes of the three cassettes are guided through the same port than the cassettes are transported. During the cassette removal process, the cooling pipes are first removed and carried out from the tunnel. After that the cassettes can be removed.

Each of the blankets has also a drain pipe for the cooling system at the divertor area. Those pipes are guided through the maintenance tunnel (Figure 3.44).

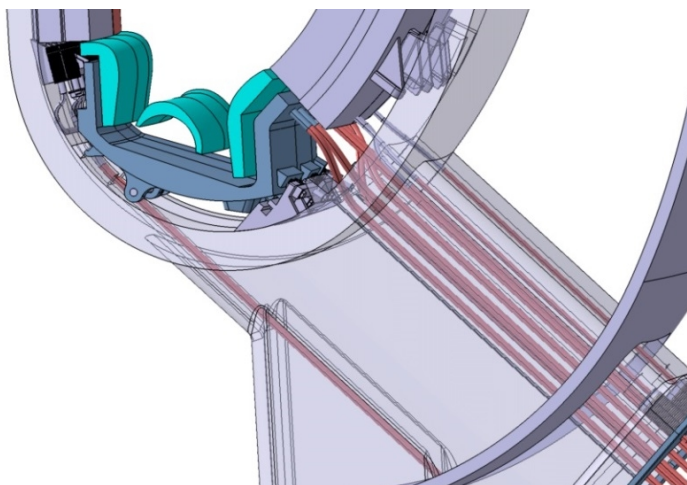

Figure 3.44. Cassette cooling pipes and the blanket draining pipes are routed through the ports.

The DEMO ports and components to be handled will be equipped with suitable interfaces to interact with RH-devices and to allow replacement operations. Some of the adopted interfaces are:

- Docking system between the maintenance tunnel and the cask
- Rails in the radial tunnel for the RH equipment
- RH-compatible locking/attachment of divertor components into the reactor
- RH-compatible cooling pipe connections.

Since the cassette replacement does not need in-vessel transporter, there are no toroidal rails needed in the vessel. However, the blanket handling system is under development by CCFE and the blanket handling system will have interactions also to divertor region.

Since the divertor cassettes are not planned to be reused, they are considered as waste after the removal from the vessel. Same applies to cooling pipes removed from the vessel. Therefore logistics plans are considering efficient ways to transport the waste from the reactor instead of transporting each cassette separately like in ITER maintenance.

Further aspects that guide DEMO design and RH equipment are the high reliability of the systems and the rescueability and recoverability in case of any type of failure during the RH operations.

3.8.4 Continuing the work on RAMI methods & tools

EFDA Task(s):	WP13-DTM02-T02; WP13-DTM02-T04
Research scientist(s):	R. Tuominen, T. Ahonen, VTT
Collaboration:	J. Harman, EFDA CSU Garching CCFE (UK), ENEA (IT), CIEMAT (ES), LEI (LT)

A common set of tools and methods are required in order to support the analysis of the DEMO plant and systems from the RAMI (Reliability, Availability, Maintainability and Inspectability) perspectives. The RAMI program along with associated tools and methods must become fully integrated with the DEMO development process to ensure that both a priori analyses based on the concept design and existing RAMI knowledge (i.e. from JET, Tore Supra, ITER, etc.) can be systematically captured and used as the basis for decisions on DEMO design.

The work started in the WP12-DTM02 on specification of RAMI tools and methods for the DEMO development process was continued in this study project in collaboration with CCFE, ENEA, CIEMAT, and LEI. The tasks in WP13 focused in DEMO plant availability simulations, the analysis of time-variant states and modes, integration of the diverse input data for RAMI predictions, and further analysis of the DEMO availability requirement. In VTT contributed on the specification of RAMI data development methods, especially concerning methods for structured expert judgment, and elaboration of the analysis of the DEMO availability requirement.

4. CSU and JOC Secondments, TFL Activities, Staff Mobility and Training

4.1 EFDA CSU Secondment

Name of Seconded:	Johnny Lönnroth
Sending institution:	Aalto University
Host organisation:	EFDA CSU Culham, Programme and Analysis Group
Reporting period:	1 January – 31 December 2013

J. Lönnroth has acted as Responsible Officer in the Programme and Analysis Group in the JET Department of the EFDA Close Support Unit at EFDA-JET in the United Kingdom during the entire year 2013.

The work as Responsible Officer has involved assisting with the coordination, preparation and implementation of the JET Work Programme. The most important duty in this regard has been to coordinate the manning of JET during the experimental campaigns with visiting scientists from the EFDA Associates. This has involved preparing official Calls for Participation, processing the responses to such calls, selecting the required scientists, preparing the formal paperwork for the visits and managing changes to the visits. Around 280 visiting scientists from EFDA Associates participate in the JET campaigns under secondment, in addition to which around 70 scientists from the host organisation CCFE and around 150 other visitors take part. The work has been carried out in close collaboration with the JET Task Force Leaders and senior management in the CSU. Other duties have included to help establish the JET programmatic priorities in collaboration with the Task Force Leaders and to supervise the work done by the JET Task Forces.

A further area of responsibility has been the technical supervision of the JET Operation Contract in interaction with the JET Operator. Most importantly, this work has involved monitoring the activities of the JET Operator in maintaining and upgrading the suite of high level analysis codes provided to JET scientists and to set priorities for the development of these codes.

The duties as Responsible Officer have also included being responsible for providing the JET interface to the EFDA Integrated Tokamak Modelling Task Force, to the International Tokamak Physics Activity expert groups and to the IEA

Large Tokamak Agreement. In particular, the work has involved coordinating and managing the licence agreements for the use of JET analysis codes on other machines and by non-EFDA parties.

4.2 CCFE JOC Secondments

4.2.1 JET Plasma Boundary Group

Name of Secondee:	Kalle Heinola
Sending institution:	University of Helsinki
Host organisation:	Experiments Department, JET Plasma Boundary Group
CCFE supervisor:	Dr. Guy Matthews
Reporting period:	1 January – 31 December 2013

Kalle Heinola has been seconded since 1st of February 2012 to Erosion/Deposition Section at JET Plasma Boundary Group in CCFE. Secondment is long-term for four years as Plasma-Wall Interaction Scientist. The Erosion/Deposition Section is respon-sible for the long-term material migration and fuel retention studies in the ITER-Like wall (ILW) and Following-ILW campaigns (FILW). These studies involve installing and replacing both passive and active diagnostic systems in dedicated interventions in-between experimental campaigns.

Main responsibilities of the Secondee are:

- Organising, with the assistance of JOC technical staff, removal of long-term samples and their sending to European Associations participating in the surface analysis activity
- Design, procure and install of long-term samples required for future JET operation
- Participation in development of new surface diagnostic concepts
- Co-ordination of JOC activities linked to exploitation of the marker tiles
- Assisting with operation and/or maintenance of JET systems for which the JET Plasma Boundary Group is responsible of.

Summary of Secondee's activities during the reporting period 2013:

- Member of the Project Planning Board for shutdowns 2014 and 2016 (Project: In-Vessel Replacements, IVER)
- Participation in surface analyses of JET carbon first wall tiles
- Development of a numerical 3-D fitting tool used for surface profiling and scripting surface analysis routines
- Surface analysis of replacement W and Be tiles for FILW intervention 2013 (JW13-FT-3.82 "Material transport and erosion/deposition in the JET torus")

- Research for a 3-D Non-contact Surface Profiling measurement system
- Participation to the JET FILW intervention taking place in beginning of 2013
 - Diagnostics: wiring survey and power supplies for Quartz Microbalance diagnostic (QMB), improvement of ex-vessel QMB diagnostic system and installation of the upgraded QMB systems. Participation to JET Experiment M13-03.
 - Diagnostics: Rotating Collector mechanism and wiring installation
 - Diagnostics: replacement Mirror sample reflectivity measurements (JW13-FT-3.78 “Analysis of mirrors exposed in JET-ILW and procurement of mirrors for exposure in JET 2014 campaigns: First Mirror Test for ITER”)
 - Carrying out ^{10}Be Sampling Experiment in JET Beryllium Handling Facility 3 (JW13-FT-3.77 “Marker experiment with ^{10}Be in JET with ITER-like wall”)
- Fusion Technology Tasks
 - Participation to Task JW13-FT-5.55 “Activation analysis of JET in-vessel components following DT irradiation”. Coordination of sample preparation for trace element analysis to be carried out at Univ. of Helsinki
- Participation in JET operation
 - Visual Systems Operator (VSO) during experimental campaigns
- Participation in JET EDGE Modelling Meetings
 - Plasma parameters from JET experiments and EDGE2D modelling to be used in Multi-scale Modelling of fuel retention in JET divertor. Multi-scale calculations are performed with Rate Theory Equations combining results from first-principles DFT calculations, MD simulations and experimental/EDGE2D data.

4.2.2 JET Data and Codes Management Group

Name of Secondee: Tuomas Koskela
Sending institution: Aalto University
Host organisation: JET Data and Codes Management Group
Reporting period: 1 January – 31 December 2013

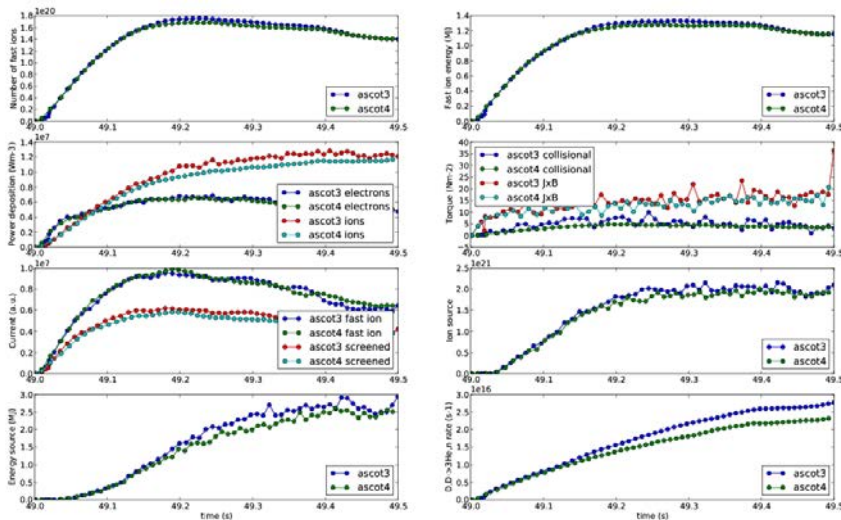

Figure 4.1. Comparison of volume integrated signals produced by ASCOT3 and ASCOT4 in a fully predictive JINTRAC simulation. The match is very good and we see ASCOT4 produces smoother torques and power depositions. The difference in the fusion rates is thought to be due to the different method used in its calculation. This might be an improvement, since ASCOT3 has historically overestimated the fusion rate calculated by, e.g., TRANSP.

The JET integrated modelling group has concentrated on the task of understanding core transport in the recent JET experiments with the metallic ITER-like wall. Of particular interest is the poloidal asymmetry of heavy impurities due to centrifugal effects. Evidence for low field side accumulation of tungsten is routinely observed in bolometry and soft X-ray emissivities of JET ITER-like wall (ILW) plasmas. Poloidal variation of high-Z impurity densities in the core of NBI heated plasmas is expected due to charge displacement and parallel electric field generated by the centrifugal force.

The poloidal distribution of tungsten was calculated from the parallel pressure balance based on 1D JINTRAC transport simulations and verified with soft X-ray measurements. JINTRAC-ASCOT was then used to study the effect of a poloidally asymmetric tungsten distribution on the distribution of the NBI heat source term. It was found that the asymmetric tungsten distribution redistributes the ionization and

slowing down distributions of the beam ions, but with the low concentration of tungsten found in JET plasmas the effects on the heat deposition profile is negligible.

The ASCOT module in JINTRAC has been kept up-to-date with the most recent trunk revision of the Aalto group with trunk_r4015 being the latest official release. New features have been developed for including the poloidal distribution of heavy impurities due to centrifugal effects, using the beam stopping coefficients from the local installation of the ADAS database at JAC and to interfacing with magnetic perturbations calculated by the MARS-F code. A JINTRAC interface for ASCOT4 has been written and tentatively tested to run on the JAC cluster and produce identical benchmark results to the ASCOT3 module, as demonstrated in Figure 4.1. Integrated transport simulations including NTMs with JINTRAC-ASCOT4 are planned for 2014.

4.2.3 JET Neutron Group

Name of Seconded: Marko Santala
Sending institution: Aalto University
Host organisation: JET Neutron Group
Reporting period: 1 January – 31 December 2013

The work is reported in Sections 3.7.1 and 3.7.2.

4.3 Task Force Leader Activities

Name of Seconded: Jari Likonen
Sending institution: VTT
Host organisation: EFDA JET
Reporting period: 1 January – 31 December 2013

In 2013 Dr. Jari Likonen acted as a deputy task force leader for Fusion Technology. His primary activities included the coordination of post-mortem analyses of JET wall and divertor tiles, and preparation for the 2014 workprogramme. Likonen was stationed at VTT, but he made visits to JET on a monthly basis. The task force leader assignment ended in December 2013.

In 2013, first JET-ILW tiles became available for post-mortem analyses and careful planning of the analysis strategy was made in order to provide preliminary results on a timely manner for PFMC conference in May 2013. Likonen was in charge of the planning and preparation of samples from the divertor tiles to be delivered to several different laboratories in Europe. He arranged progress meetings at different associations, such as at MEaC (Romania) and AEUL (Latvia), including a review meeting on ion beam analyses at IST (Portugal) with participants from several different associations. In addition to these meetings, he arranged several progress meetings remotely. Two TF-FT monitoring meetings were arranged in 2013 and he presented the tile analysis programme for 2013 and

planning for the post-mortem analyses in 2014. He prepared the JET 2013 monitoring report on plasma facing components under TF-FT. Other duties included clearance of JET manuscripts for conferences such as PFMC and scientific journals.

4.4 Staff Mobility Visits and Reports

4.4.1 Framework agreement between Associations Tekes and IPP: Power and particle exhaust

Names of seconded persons:	L. Aho-Mantila, A. Hakola, S. Koivuranta
Sending institution:	VTT
Names of seconded persons:	M. Groth, T. Kurki-Suonio, T. Makkonen, J. Miettunen
Sending institution:	AU
Host institution:	IPP Garching

Leena Aho-Mantila studies power exhaust physics using 2D edge modelling in comparison to fuelling and seeding experiments in present-day full metal devices. The objective of the work is to validate the radiative scrape-off layer and divertor models in the SOLPS code packages in order to derive credible predictions for a future power plant. For this purpose, she coordinates and analyses dedicated model validation experiments in ASDEX Upgrade (AUG), in close collaboration with the ASDEX Upgrade team, and works with the SOLPS code developers and experts at IPP.

Mathias Groth will be visiting IPP Garching for 2–3 weeks to work with Drs. D. Coster and M. Wischmeier on setting up, running, and post-processing SOLPS5.1 for JET, AUG, and DIII-D L-mode plasmas. This work is based on his previous simulations using SOLPS5.0. The simulations will be post-processed for synthetic diagnostics for both SOLPS versions, and compared to measurements in one or all three tokamaks. The goal of this exercise is to quantify the role of neutral-neutral interactions and molecular ions on detachment.

Toni Makkonen, under the supervision of Dr. Th. Pütterich, has studied the high-field side SOL flow profiles in AUG using active methane injection. The ensuing emission plume was followed using a fast video camera with appropriate filters for CII and CIII and a spectrometer with up to 8 parallel lines of sight. The observed carbon flow profiles serve as proxies for SOL impurity migration. Furthermore, ERO simulations have been carried on the coupling to the background flow. Results were presented at PSI 2012 and a paper was submitted to CPC.

Juho Miettunen, together with Dr. T. Kurki-Suonio, has enhanced the ASCOT code so that it can be applied for impurity tracing in the SOL. Results from extensive simulations have been published in NF, and they show that the 3D features of the first wall should not be ignored in impurity migration studies. Furthermore, ASCOT has been used to predict deposition patterns for different impurity atoms (e.g., C and N), and measurements show a remarkable agreement with simula-

tions. Now it is high time for Miettunen to learn to evaluate and extract experimental data from AUG and get networked with the relevant researchers at IPP.

Taina Kurki-Suonio supervises the PhD work of the Aalto students at IPP in the fields of PWI and fast ion physics. She wants to keep a close contact to the experimentalists at AUG in order to serve well in the AUG program committee.

Antti Hakola is in charge of ion-beam analyses of various plasma-facing components such as marker tiles prepared for campaign-integrated erosion/deposition studies and marker probes produced for discharge-resolved erosion investigations in AUG. Hakola is also the responsible officer for the global impurity-migration experiments at AUG. All this research is done in collaboration with Drs. Albrecht Herrmann, Karl Krieger, Matej Mayer, Hans Werner Müller, Volker Rohde, and Kazuyoshi Sugiyama and requires several weeks of stay at IPP annually.

Seppo Koivuranta carries out ion-beam measurements of marker tiles at IPP together with Dr. Hakola.

4.4.2 Erosion and retention investigations of ASDEX Upgrade marker tiles and probes (1)

Name of seconded person:	A. Hakola
Sending institution:	VTT
Host institution:	IPP Garching
Dates of secondment/missions:	6–18 January 2013

4.4.2.1 Work Plan/milestones

1. RBS/NRA measurements of ASDEX Upgrade (AUG) wall tiles
2. Exposing a graphite probe to H-mode plasma discharges in AUG

4.4.2.2 Report

Milestone 1: This milestone dealt with Rutherford Backscattering Spectroscopy (RBS) and Nuclear Reaction Analysis (NRA) measurements of 8 marker tiles, removed from the upper divertor of AUG during the summer opening of the vessel in 2012. The tiles had 1.5–2 μm thick poloidal W, Mo, Cr, and Ni marker stripes on graphite, and they had been exposed to plasma during the period March–July 2012. The RBS results will be compared with the corresponding data extracted from the tiles before their plasma exposure to determine erosion of the markers, while the NRA data will reveal the amount of deuterium, boron, and carbon deposited on the coatings.

The analyses were made in the accelerator lab of IPP using the Bombardino analysis chamber. In the RBS measurements, protons with an energy of 3.0 MeV were used, and the energy spectrum of the backscattered particles at 165° was detected. The NRA measurements, for their part, were carried out using $^3\text{He}^+$ ions with an energy of 2.5 MeV and recording the spectrum of protons formed in the

nuclear reactions ${}^3\text{He}(d,p){}^4\text{He}$, ${}^3\text{He}({}^{11}\text{B},p){}^{13}\text{C}$, and ${}^3\text{He}({}^{12}\text{C},p){}^{14}\text{N}$ at 150° . Both in RBS and NRA the step between adjacent measurement points along each marker stripe was 10–15 mm.

Qualitatively the results indicate that little erosion has taken place while many of the tiles show a relatively thick boron-rich deposited layer. Quantitative picture on the erosion/deposition behaviour at the upper divertor will, however, be obtained only after the measurement data have been carefully analysed in late 2013.

All the planned measurements were carried out and this milestone was therefore reached.

Milestone 2: The second topic of the present visit was exposing one marker probe to H-mode plasma discharges in AUG. The probe had four 5-mm wide, 30–50-mm long, and 50–100-nm thick marker stripes. The distance between the stripes was approximately 5 mm on an oval-shaped surface, tilted by 45° from the horizontal reference plan; This allowed one to study not only erosion of the markers but also re-deposition of the eroded material. The materials of the marker stripes were carbon (in the form of diamond-like carbon, DLC, with a thin intermediate layer of tungsten), aluminium, nickel, and tungsten.

The probe was attached to the midplane manipulator of AUG such that the marker stripes were facing the magnetic field lines with the 45° angle of incidence and with magnetic connection towards the lower divertor. During the discharges, the tip of each probe was moved by some 20 mm outside the limiter shadow, approximately to a distance of 45 mm from the separatrix.

The probe was exposed to four low-power H-mode discharges in deuterium. The relevant ASDEX Upgrade discharges were #29187-29190, and the most important plasma parameters were $I_p = 0.6$ MA, $B_t = -2.3$ T, and $n_e = 5.4 \times 10^{19} \text{ m}^{-3}$. The auxiliary heating power was 2.4 MW of NBI and up to 1.8 MW of ECRH. The flat-top time of each discharge was around 6.3 s, thus the cumulative exposure time of the probe was approximately 25 s.

Visual inspection after the experiment showed that the metallic stripes had survived well from their plasma treatment: Only a few arc tracks could be seen on the W and Ni markers close to the tip of the probe, which had been closest to the plasma. In contrast, the DLC stripe had been clearly eroded and partly damaged. Moreover, the uncoated region close to the tip of the probe looked bluish after the experiment indicating either a thin deposited layer on the surface or surface being modified due to excessive heating.

The erosion measurements of the marker stripes will be carried out during a later mobility visit in 2013. The planned experiment was successfully carried out and the milestone was thus reached.

4.4.3 SOLPS modelling of ASDEX Upgrade low-density discharges with and without impurity seeding

Name of seconded person: L. Aho-Mantila
Sending institution: VTT
Host institution: IPP Garching
Dates of secondment/missions: 8 January – 12 July 2013

4.4.3.1 Work Plan/milestones

The purpose of this visit is to develop credible solutions for low-density ASDEX Upgrade discharges using the SOLPS code package. Dedicated L-mode discharges were performed in ASDEX Upgrade in 2012 to achieve a set of well-characterized discharges for the purpose of model validation. The discharges were performed in forward and reversed field, to analyse the importance of drift effects in the edge plasma, and with various levels of impurity seeding to assess the characteristics of power exhaust physics. The main focus of this visit is the analysis of the low-density branch of this experimental data set. For this purpose, SOLPS5.0 simulations will be performed with all available physics models included in the calculations. The simulation results will be compared with multiple diagnostic measurements via implementation of synthetic diagnostics in the code package.

The visit is a part of the EFDA fellowship work of Leena Aho-Mantila. Collaboration with the experimental and theoretical groups at IPP is essential for successful implementation of the work.

Goals:

1. Assess data analysis needs for the low-density L-mode experimental data set and coordinate the analysis work
2. Identify gaps in the experimental data set and complete it by executing new discharges if possible
3. Achieve converged SOLPS5.0 solutions for as many discharges as possible within this data set
4. Compare the results of these SOLPS5.0 solutions with available experimental data and develop the solutions further.

4.4.3.2 Report

The analysis work during this visit focused on the following set of ASDEX Upgrade L-mode discharges:

- Unseeded discharges with 5 different density levels ($1.6\text{--}4.0 \times 10^{19} \text{ m}^{-3}$)

- Unseeded discharges with reversed Bt and Ip and 2 different density levels ($2.2\text{--}3.6 \times 10^{19} \text{ m}^{-3}$)
- Seeded discharges with a steady plasma density level ($4.0 \times 10^{19} \text{ m}^{-3}$) but 3 different N seeding levels.

Goal 1: Although several diagnostic measurements were readily available for analysis, certain key data required separate evaluation or additional validation. During this visit, Dr. R. Fischer provided calculations of Z_{eff} for the N seeding scan and performed additional IDA analysis of the electron density profiles at the outer midplane. Drs. R. McDermott and E. Viezzer evaluated the ion temperature profiles at the outer midplane, and Dr. S. Müller provided X-point probe measurements of plasma parameters and flow velocities. The most time-consuming analyses were the deconvolutions of radiation measurements, which were performed by Mr. M. Bernert for the discharges with normal field configuration, and the Doppler Er measurements, which Dr. G. Conway evaluated for the unseeded discharges in both field directions. Interpretations of several other diagnostic measurements were discussed in addition.

Goal 2: In the beginning of the visit, the discharges with the lowest plasma densities ($1.6\text{--}2.0 \times 10^{19} \text{ m}^{-3}$) could not be analysed in detail due to lack of strike point sweeps and spectroscopy measurements. Therefore, new discharges were performed during this visit to analyse this lowest density regime in detail. These new discharges enabled detailed comparisons with modelling.

Goal 3: SOLPS5.0 simulations were set-up and run for each of the discharges listed above. The average convergence times were several months with drift terms activated, but first converged solutions could be obtained for all cases when using a rather coarse mesh with 48x18 cells. Runs using a finer mesh with 96x36 cells were performed for certain cases, but they suffer from very long convergence times.

Goal 4: The unseeded discharges in normal field configuration were the fastest ones to converge, which allowed for fitting of the simulation assumptions (e.g. transport coefficients) using information obtained from the experiments (e.g. upstream profiles). In this context, a synthetic diagnostic was also built into the code package, which enabled comparison with experimental inner divertor densities obtained from Stark broadening measurements. In future visits, these comparisons will be extended to cover more discharges and diagnostic measurements.

4.4.4 Momentum and particle transport, joint ITPA Experiment TC-15 and TC-17 between JET, DIII-D, NSTX, C-Mod and ASDEX Upgrade

Name of seconded person: T. Tala
Sending institution: VTT
Host institution: IPP Garching
Dates of secondment/missions: 13–19 January 2013

4.4.4.1 Work Plan/milestones

Tuomas Tala is the spokesperson of ITPA TC-15 Joint Experiment and he will act as a scientific co-ordinator of ITPA TC-15 experiment on ASDEX Upgrade (AUG) together with Dr. R. Mcdermott, as he has already done on DIII-D, JET and C-Mod.

Momentum transport studies have been performed on AUG in 2011–2012 and several scans have already been finished such as the q-scan, part of the R/L_n scan and the collisionality scan (turned out to be difficult to do). What is left for 2013 is, using the upgraded ECRH power and possibly complementing it with ICRH power, i.e. momentum transport studies in TEM dominated plasma. The main point is to quantify whether the pinch exists and is as large as in ITG dominated plasmas and which part of the change in rotation originates from the modified intrinsic torque in ITG/TEM transition and which part from the modified pinch. So far, no good NBI modulation data has ever been taken on electron heating dominated plasmas. Another quantity to be studied with fast NBI modulation is beta, its influence on momentum transport has never been studied. Here a high beta plasma is proposed with NBI modulation in N seeded high power ECRH scenario. A repeat of the q-scan will be possibly performed as the results from 2012 were controversial.

The first set of intrinsic torque experiments was performed in 2012 by using the slow NBI modulation technique (2 Hz). The uncompensated modulation at 2 Hz does create a large enough perturbation, but in many shots the noise level, either due to sawtooth, ELMs or some long term trends, makes the analysis challenging. For 2013, the experiment will be planned carefully to decrease the noise level in the momentum data (and NBI torque data). RMP coils will be used to suppress ELMs and longer modulation periods used to get more modulation cycles to minimise the noise level. Several physics scans using this technique including ECRH and ICRH dominated plasmas (TEM dominated) and a dimensionless ρ^* scan between JET and DIII-D will be performed.

4.4.4.2 Report

New experiments were planned and executed on AUG to study intrinsic torque under ECRH and with varying Q-profile. The following report mainly focuses on the subsequent analysis of the obtained data. 16 successful discharges were executed, shared equally by momentum transport studies (10 Hz modulation) and

intrinsic torque studies (2 Hz modulation). While momentum transport analysis work is still on-going, the preliminary results from the intrinsic torque studies exist.

Here the effect of ECRH was studied in two 600 kA plasmas with NBI modulation by injecting 3.4 MW of ECRH in the latter half of the discharge on top of 3.7 MW of NBI power. The steady state rotation was reduced by about 20% after the application of the additional power from ECRH. The influence of the additional ECRH is completely opposite in these discharges. In the ITG dominated case the application of ECRH does not appear to modify the transport. Instead almost 2 Nm of counter current torque is generated into the plasma. Note that the total intrinsic torque is still positive due to the underlying co-current intrinsic torque which is not due to ECRH.

The effect of the q-profile on the intrinsic rotation was studied by changing plasma current from 400 kA to 1 MA while keeping toroidal magnetic field constant. This resulted in the q95 (q at $r/a = 0.95$) variation by almost a factor of 3 ranging from about 4 to 11. However, since the plasma density in AUG tungsten wall is strongly linked with plasma current via the Greenwald density it is practically impossible to change the q95 value without changing the plasma density. Therefore, more heating was applied in the high current high density cases to keep the collisionality as constant as possibly (in practise it worked to about 30%). The resulting integrated intrinsic torque profiles from this scan show a clear trend indicating that the intrinsic torque increases with increasing plasma current one must note that the associated error bars are also substantial. Nevertheless, all the cases have in common that the intrinsic torque has a rather broad profile with the main contribution coming from outside $r/a = 0.4$ which is somewhat different that has been observed previously on DIII-D where the torque was quite strongly edge localised.

4.4.5 JINTRAC simulation project on fuelled and seeded JET baseline ELMY H-mode plasmas

Name of seconded person:	A. Järvinen
Sending institution:	AU
Host institution:	FZ Jülich
Dates of secondment/missions:	14–25 January 2013

4.4.5.1 Work Plan/milestones

1. Learn to run and understand the integrated code-suite JINTRAC with the guidance of Dr. Sven Wiesen.
2. Initialize the required simulations, perform simple parameter scans, and understand / post-process the code output.

4.4.5.2 Report

The primary purpose of visiting FZJ was to initialize time-evolving simulations of those plasmas with the core-edge integrated code-suite JINTRAC. The overarching goal of the research project is to conduct interpretive and predictive numerical studies for tungsten transport in the deuterium fuelled and nitrogen seeded JET ILW ELMy H-mode plasmas. The numerical tools are EDGE2D/EIRENE and DIVIMP on the one hand, and JINTRAC and DIVIMP on the other hand. The specific milestones set for the visit were to learn to run and understand the integrated code-suite JINTRAC with the guidance of Dr. Sven Wiesen, and to initialize the required simulations, perform parameter scans, and understand / post-process the code output. All the specified milestones were successfully achieved.

JINTRAC/COCONUT simulations with full coupling between JETTO and EDGE2D/EIRENE were initialized for two magnetic configurations of JET: 73569 and 82806. The first one was used as a fast track to the parameter scans, while setting up the second one, which represents the actual magnetic configuration used in the experiment. After a successful coupling between the codes, parameter scans were initialized to identify the relevant parameter space to be used in the study. JINTRAC simulations with both the continuous and discrete ELM models of JETTO were initialized. The first one was used to tailor the edge plasma profiles to represent specified normalized edge pressure gradients in the plasma, while the second one will be used in the actual ELM modelling simulations. Finally, a detailed continuation plan was derived, including a designed set of parameter scans to investigate the following scaling relations in the code:

- How do the pedestal and core densities and temperatures scale in fuelling rate, and assumed cross-field transport parameters?
- How do the ELM magnitude, the ratio of the convective to conductive ELM losses, and the ELM frequency scale with these variables?
- How does the functional shape of the normalized pedestal pressure gradient scale?

Once these scaling relations are studied, which is foreseen to take a month or two, a second round of parameter scans with a planned protocol in the parameter space using the scaling relations obtained during the first round is foreseen to be sufficient to reach a satisfactory model for the reference plasmas. Once satisfactory reference simulations are obtained, the full matrix of fuelling and seeding scans will be studied, by spanning through the parameter space assuming that the edge transport barrier cross-field parameters scale proportionally to the square-root of puffing rate, based on the experience with the project. In this process, the ELM magnitudes will also be adjusted to accommodate the pedestal collisionality scaling of the conductive ELM losses.

4.4.6 LIBS measurements of Be test samples

Name of seconded person: A. Lissovski
Sending institution: UT
Host institution: VTT
Dates of secondment/missions: 27 January – 1 February 2013

4.4.6.1 Work Plan/milestones

1. Test beryllium-compatible Laser Induced Breakdown Spectroscopy (LIBS) system containing a new Nd:YAG laser
2. Recording LIBS spectra depending on the laser fluence and type of samples
3. Analyse results and develop the methods for further experiments with beryllium

4.4.6.2 Report

Up to now, the LIBS data on pure beryllium and Be-containing mixed materials is largely missing even though the importance of studying beryllium samples has been stressed many times. Be needs special care in handling it in dedicated facilities such as those at Tekes-VTT. VTT has now a beryllium-compatible LIBS chamber available which is similar to the system in University of Tartu. In December 2012, VTT purchased a new powerful Nd:YAG laser that allows potentially measuring with higher laser fluences. It can play a significant role in the determination of deuterium in implanted samples.

For the experiments discussed here, a set of samples with Be containing coatings – pure Be films on stainless steel (SS) substrates and W-Be coatings with a percentage of Be about 70% on SS – have been prepared in mutual cooperation with our Romanian partner Cristian Lungu from the MEdC Association. The samples were pre-characterized at IPP-Garching and then shipped to VTT for analyses.

Milestone 1: During the first day of visit, the beryllium-compatible LIBS system containing a new Nd:YAG laser has been tested. The necessary settings of the system were determined: triggering, delay times, fluences, positions of stepper-motor driven rotating mirror, stability of laser beam etc. The system is suitable for proper LIBS experiments. This milestone was reached.

Milestone 2: During the visit, altogether 6 Be-containing samples, 2 W-Al containing samples and 2 reference Al-samples were analyzed. The emission spectra from different samples were recorded with Andor SR750 spectrometer and ICCD camera iStar, perpendicular to the laser beam, in the spectral range 250–670 nm, with delay about 100 ns from the laser pulse and gate pulse width 500 ns. The experiments have been made at fluences in the range 5–30 J/cm². This milestone was reached.

Milestone 3: The behaviour of spectral emission versus laser shot number showed the relatively slow decrease (without sharp drop) of the intensity for the diagnosed Be and W lines. One reason of such effect could be due to the shape of the laser spot. Therefore the next task would be to investigate the crater profiles on sample after 1, 2, 5, 10 etc. shots at corresponding fluences. The behaviours of Be, Al and W lines versus laser shot number for Be-W and Al-W coatings are received. The further interpretation and necessary corrections of these results will be done at home university. This milestone was reached.

4.4.7 Participation in the project meeting of JET TF-FT Task JW13-FT-3.80

Names of seconded persons:	A. Lasa
Sending institution:	UH
Names of seconded person:	J. Likonen
Sending institution:	VTT
Host institution:	MEdC
Dates of secondment/mission:	12 February 2013

4.4.7.1 Work Plan/milestones

Participation in the project meeting of JET TF-FT Task JW13-FT-3.80.

4.4.7.2 Report

The aim of the meeting was to discuss the thermionic vacuum arc technique (TVA) that will be used for preparation of the mixed Be-W coatings and about the surface analyses for the characterisation of the coatings. Moreover, during the meeting it will be discussed about the basic mechanisms of the TVA method and how the formation of mixed materials can be simulated with molecular dynamics (MD) and what kind of experimental data would be needed as an input to the MD simulations. During the meeting there were 6 presentations and two additional presentations given by Dr. Porosnicu and Tiseanu.

J. Likonen gave an overview presentation on PWI studies at JET and post-mortem results under TF-FT. The general picture of erosion/deposition at JET is the following. Impurities (C, Be and metals) eroded from the main chamber deposited on inner divertor tiles 1 and 3. Then C is preferentially sputtered and transported towards the divertor corner. This leaves a Be-rich (and Ni-rich) layer on the tiles. The greatest values of the Be/C ratios at the surface of the deposits near the bottom of tile 1 and top of tile 3. At the divertor base there is heavy deposition on the sloping parts and shadowed areas of each tile 4 and 6. Outer divertor tiles 7 and 8 clean, indicating that they were generally in a net erosion zone.

Extrapolations from local measurements of erosion and deposition give a net erosion for the entire main chamber of about 462 g and a net deposition in the divertor of about 698 g, upon which the amount of dust collected (~300 g) has to

be added, to give a total net deposition in the divertor of about 998g. The amount of the net deposition is thus about twice as large as the amount of the net erosion. Considering the sources of uncertainties in scaling the results from representative tiles to the whole torus, the agreement within a factor of two is acceptable.

During the ITER like wall shutdown in 2009–2011 several marker tiles for erosion/deposition studies were installed in the divertor, outer poloidal limiter, inner wall guard limiter, dump plate area and in between the inner wall guard limiters. First set of tiles have been removed in 2013 during intervention and the tiles will be available for post-mortem analyses in 2013.

A. Lasa presented the principles of the molecular dynamics (MD): (i) simulate atoms, (ii) calculate interatomic forces for each configuration, (iii) follow trajectories, (iv) accuracy depends on the potential, (v) scale: nm,ns, (vi) include: many-body and bonding related effects, (vii) miss: long-term effects.

With MD irradiation effects in solids structure relaxations (formation) can be investigated and various physical parameters can be calculated, such as sticking coefficients, sputtering yields, depth profiles, bond angles and follow trajectories. However, diffusion and electronic effects can not be simulated with MD. Finally Lasa presented some first results on bombardment of W with Be ions with various energies.

4.4.8 Neutral beam current drive modelling (1)

Name of seconded person:	O. Asunta
Sending institution:	AU
Host institution:	CCFE
Dates of secondment/missions:	25 February – 8 March 2013

4.4.8.1 Work Plan/milestones

Steady-state operation of a tokamak requires the toroidal current to be driven non-inductively. Moreover, driving current off-axis is of vital importance for the steady-state (or advanced) operating scenario in ITER where it is needed for tailoring the q-profile in order to avoid detrimental magnetohydrodynamic (MHD) activity. One means foreseen for driving off-axis current is using neutral beam injection (NBI). In MAST (Mega Ampere Spherical Tokamak) experimental evidence of off-axis neutral-beam driven current has been observed.

The purpose of the proposed visit is to continue modelling neutral beam injection (NBI) and current drive in MAST with three codes: ASCOT/JINTRAC, NUBEAM/TRANSP, and LOCUST-GPU. In 2012, ASCOT was successfully run using MAST data within JINTRAC suite of codes at CCFE. It was, however, discovered that the particle guiding-centre following codes ASCOT and NUBEAM had some discrepancies, whereas LOCUST-GPU was not yet ready for the comparison. The above mentioned discrepancies between the codes should be understood and fixed, and LOCUST-GPU should be included in the comparisons. The

need for a more extensive and 'cleaner' code benchmark using reduced physics models will also be discussed during the proposed visit. Based on earlier experience, the finite Larmor radii of the particles should be taken into account when modelling MAST NBI, but the current results of ASCOT with full-orbit following (ASCOT-FO) seem strange and need to be checked.

What is more, until now, a limited flux map and a simplified rectangular wall have been used in the ASCOT simulations ran within JINTRAC. Using a more realistic description for the wall and a flux map that extends all the way to the wall is expected to have an impact on the results and, therefore, one of the goals of the proposed visit is to work on importing those to ASCOT.

During my mobility visit I wish to accomplish the following tasks:

1. Understand the reasons behind the discrepancies in the NUBEAM and ASCOT results, and fix the possible bugs and differences in the inputs and/or physics models.
2. Study and understand the ASCOT-FO simulations of MAST NBI that are producing peculiar results and fix the possible bugs in the code.
3. Work with Dr. S. Pamela and Dr. M. Romanelli on importing the full poloidal magnetic flux map into ASCOT/JINTRAC to be able to model the particles all the way to the actual MAST wall.
4. Discuss the need for an extensive benchmark exercise between ASCOT, NUBEAM, and LOCUST-GPU with Dr. R. Akers and Dr. D. Keeling.

4.4.8.2 Report

The goals set for the visit were more or less accomplished:

1. Differences in the flux map and, consequently, the magnetic field were discovered to be the main reason behind the discrepancies in the results of the guiding-centre following simulations performed using NUBEAM and ASCOT. Also, the surprisingly large amount of charge-exchange reactions in NUBEAM is causing the results to differ. New NUBEAM simulations with limited physics models are needed to get a better idea of the differences in the codes.
2. Part of the problem in the full-orbit following of ASCOT was related to the flux map (see above). Also some bugs in the code were found and fixed, but the work is still on-going.
3. Extended flux map was successfully imported to ASCOT. This also allowed using a more realistic description of the first wall.
4. We agreed with Dr. R. Akers and Dr. D. Keeling that a comprehensive benchmark between the three codes and their different models (ASCOT-FO, ASCOT-GC, NUBEAM with and without Larmor correction, and

LOCUST-GPU) is needed. There was not enough time to get started with the work, though.

Lot of work remains to be done, but we made some very good progress during the visit.

4.4.9 Studying irradiation defects in tungsten

Name of seconded person: A. Sand
Sending institution: UH
Host institution: CCFE
Dates of secondment/missions: 25 February – 2 March 2013

4.4.9.1 Work plan/milestones

The purpose of this visit is to continue collaboration which was begun in 2012, on the study of irradiation defects in tungsten. Recent experiments of in-situ self-ion irradiation in pure tungsten samples, conducted by the materials group at Oxford University, offer a unique opportunity to compare simulation results to experiments at an atomic level.

We will carry out simulations of high energy collision cascades in W, with particular attention to energy loss processes and the final damage configurations, in close collaboration with the CCFE group, where the evolution of these damage structures will be further investigated. Our method is classical molecular dynamics (MD), including electronic effects through the standard procedure of applying electronic stopping, as determined by SRIM, to atoms with kinetic energy above a certain threshold. The choice of cut-off energy for electronic stopping is found to strongly affect energy losses during the different phases of cascade development, and this has critical consequences for the size and configuration of final defects. We will investigate these effects, aiming towards a better understanding of the processes involved in formation of damage structures resulting from dense high energy cascades.

4.4.9.2 Report

Defect production in 150 keV collision cascades in tungsten was studied. Special attention was devoted to the clustering and configuration of the defects as seen in MD simulations, and comparison of the MD results to recent experimental results from in-situ irradiation studies of self-ion damaged W, performed by Xiaoou Yi from the University of Oxford. It was seen that an excessively low threshold for electronic stopping resulted in a complete lack of defect clusters of the sizes seen from single ion impacts in the experiments, while a higher threshold resulted in occasional very large SIA and vacancy clusters, in agreement with experiment. In addition, from the MD simulations, the size distribution of SIA clusters was found

to follow a power law. The power law offers a way to generate input for kMC simulations, without the need to simulate numerous cascades in MD, which is computationally heavy. A letter publication detailing this was planned and partially written during the visit.

The precise set-up of the sample and incident ions for atomic scale simulations of the experiments was determined together with Ms. Yi, in order to study through MD simulations the effect of the thin film geometry, including the proximity to two surfaces as well as 2-dimensional heat dissipation, on the primary cascade damage.

Additional benefit of this visit was gained from numerous discussions with members of the CCFE group and visiting researchers, as well as my own presentation of the ongoing work on W cascades at the Materials Department of the University of Oxford, and from discussions that followed.

4.4.10 Numerical (ASCOT) study of activation probe experiments

Name of seconded person: S. Äkäslompolo
Sending institution: AU
Host institution: IPP Garching
Dates of secondment/missions: 15–20 March 2013

4.4.10.1 Work plan/milestones

This mobility trip is an extension of my participation in the ITM code camp in Garching. I plan to stay a few extra days in Garching in order to work at tasks related to ASCOT simulations of activation experiments. Georges Bonheure *et al.* used an activation probe to measure the fast ion losses in ASDEX Upgrade. I'm working on ASCOT simulations of these measurements. ASCOT is a guiding centre following plasma simulation code developed at my laboratory.

During my mobility visit I wish to accomplish the following tasks:

1. Discuss with Benedict Geiger about the possible FIDA measurements. Fast Ion D-alpha measurements can give information about the fast ion distribution inside the plasma.
2. Learn to create high-resolution Clite magnetic equilibrium reconstruction. Mike Dunne has kindly agreed to give me a tutorial.
3. In addition to validating ASCOT against measurements, I'm also planning to verify ASCOT simulations against TRANSP. I will discuss these simulations with Giovanni Tardini.

4.4.10.2 Report

The visit to ASDEX Upgrade was successful. I'd like to report the following:

1. Benedict Geiger reported that no FIDA measurements were possible in the activation probe discharges. The density was too high. We also discussed other aspects of the experiment.
2. The tutorial by Mike Dunne allowed me to create high resolution equilibrium reconstructions for the relevant discharges.
3. We discussed the relevant TRANSP simulations with Dr. Tardini. He also promised to run TRANSP with the experimental NBI-ICRH synergy model on. I was able to extract the fusion rates and ionisation profiles from TRANSP output.

4.4.11 Studying runaway electron dynamics in tokamaks

Name of seconded person: O. Asunta
Sending Institution: AU
Host Institution: Chalmers University of Technology
Dates of secondment: 18–20 March 2013

4.4.11.1 Work Plan/milestones

Runaway electrons can jeopardize the integrity of the first wall materials in ITER and future tokamaks. Therefore, understanding their behaviour is one of the key topics pointed out by the ITER Organization. Our group at Aalto University has extensive experience in modelling fast ions using the ASCOT code and now the question is if our expertise could be used in studying runaway electrons. Dr Tünde Fülöp and her group, on the other hand, continue the long-standing tradition of runaway electron studies at Chalmers University of Technology. The purpose of this visit is to discuss possible synergies and collaboration between her group and the ASCOT group at Aalto University.

During my mobility visit I wish to discuss the following topics with Dr T. Fülöp and her group:

1. What is the group doing, what numerical tools do they currently have for runaway modelling, and what are their future plans and needs from the modelling perspective?
2. What are (i) the tools we have developed at Aalto University and VTT, (ii) their pros and cons, and (iii) their potential for studying runaway electrons?
3. How could the ASCOT group contribute to runaway modelling and what could be the topics and ways of future collaborations?

4.4.11.2 Report

Discussions were fruitful and both groups now have a better understanding of each other's work, numerical tools and capabilities. It was decided that runaway electron studies clearly have the potential for a mutually beneficial collaboration. Also some hurdles were identified. For example, exhaustive runaway studies with ASCOT are not possible without further code development due to the short time scales in magnetic and electric field evolution

4.4.12 Material migration in JET C wall and ILW plasmas

Name of seconded person: M. Airila
Sending institution: VTT
Host institution: EFDA JET
Dates of secondment/missions: 14–17 April 2013

4.4.12.1 Work plan/milestones

Material migration modelling is closely linked to SOL and divertor plasma modelling and diagnostics as well as to plasma-surface interaction modelling and post mortem surface analyses. Therefore it forms an important part of JET edge modelling activities. Participation to the edge modelling meeting will help to achieve the following milestones:

1. Collect various code results (EDGE2D/EIRENE, ERO, OSM, WALLDYN and ASCOT-PWI) obtained in 2011–13 on initial beryllium migration with the ILW and draw a combined conclusion on them
2. Revisit the 2004 ^{13}C tracer injection experiment using the recently completed OSM plasma backgrounds in ERO. In particular, investigate the local “walking” mechanism as a way to transport impurities into the PFR in the presence of re-erosion.

4.4.12.2 Report

1. Work on beryllium migration focused on searching available spectroscopy data on the initial phase of ILW operation. In discussions with Dr. Kerry Lawson, KT1 visible system data for Bel and Bell emission in #80295 was identified suitable for modelling although there are some issues with the spatial calibration.
2. OSM plasma backgrounds for #63445 were processed together with Mr. Aaro Järvinen to include the effect of electric fields into ERO simulations.

4.4.13 LIBS measurements of JET samples (1)

Name of seconded person: A. Lissovski
Sending institution: UT
Host institution: VTT
Dates of secondment/missions: 5–10 May 2013

4.4.13.1 Work plan/milestones

1. Carry out LIBS analyses of samples from the divertor region of ASDEX Upgrade as test experiments
2. Analyse the compositions of surface layers from JET samples, originating from the inner part of the divertor

4.4.13.2 Report

The visit is made as the continuation of the collaboration between Tekes-VTT and University of Tartu in the field of LIBS diagnostics for Be-containing samples.

Milestone 1: During the first two days of the visit, experiments with samples removed from the divertor region of ASDEX Upgrade were carried out. Altogether 6 graphite samples with W coatings (thickness $\approx 0.5\text{--}5\ \mu\text{m}$) were analyzed. The emission spectra were recorded using an Andor SR750 spectrometer and an ICCD camera iStar, in the direction perpendicular to the laser beam and in the spectral range 250–790 nm. The delay between recording and the laser pulse was set to 100 ns and the width of the gate pulse to 500 ns. The experiments were done using fluences in the range 5–30 J/cm². The presence of H and/or D, O, W, and C was clearly observed in the emission spectra. The depth profiles of these elements, i.e., the behaviour of the spectral emission versus the laser shot number were plotted for each sample. During these experiments, the optimal laser energy and delay time were found. This milestone was reached.

Milestone 2: The second part of visit dealt with two sets of samples, extracted from selected JET tiles that corresponded to JET operation periods 1998–2009 and 2007–2009. The set up was the same as for the ASDEX samples. All the experiments were carried out at a fluence of 20 J/cm². The strong emission lines of H and/or D, O, Be, and C were observed. The depth profiles of elements were plotted and compared with existing ion-beam data (SIMS analyses). As a result of the experiments, it is now possible to compare the corresponding samples from different operation periods of JET. This milestone was reached.

4.4.14 Neutral beam current drive modelling (2)

Name of seconded person: O. Asunta
Sending institution: AU
Host institution: CCFE
Dates of secondment/missions: 13–24 May 2013

4.4.14.1 Work plan/milestones

The purpose of the proposed visit is to continue modelling neutral beam injection (NBI) and current drive in MAST with three codes: ASCOT/JINTRAC, NUBEAM/TRANSP, and LOCUST-GPU. Earlier in 2013, the main discrepancies between the particle guiding-centre following codes ASCOT and NUBEAM were discovered to be caused by differences in the input magnetic flux maps. It was agreed with Dr. R. Akers and Dr. D. Keeling that an extensive code benchmark between ASCOT, LOCUST-GPU and NUBEAM using reduced physics models and fixed magnetic and plasma backgrounds is needed. On the proposed visit, this work will really begin in earnest.

The next step in realistic transport modelling of MAST plasmas using JINTRAC suite of codes is to run fully self-consistent predictive simulations using ASCOT for modelling the neutral beams. This will require modelling the time evolution of the magnetic equilibrium taking into account the effect of the current driven by the fast ions.

During my mobility visit I wish to accomplish the following tasks:

1. Keep on working on the ASCOT3-FO simulations of MAST NBI that are still producing peculiar results and try to speed up the calculations.
2. Compare ASCOT3 and ASCOT4 results and assess the possible differences and discrepancies.
3. Work with Dr. M. Romanelli on running fully predictive simulations using ASCOT/JINTRAC.
4. Work with Dr. R. Akers and Dr. D. Keeling on the MAST NBI benchmark between ASCOT, NUBEAM, and LOCUST-GPU. Focus on making sure the inputs for all the codes are the same and do not vary in time.

4.4.14.2 Report

What comes to the tasks I wished to accomplish:

1. ASCOT3-FO results are starting to look good, but the speed of the calculations is still an issue. As a result, being able to run the ASCOT4 within JINTRAC would be a very welcome improvement. I had some discussions on that with Mr. T. Koskela who is the ASCOT Responsible Officer at JET

and even though some functionalities are still missing, a beta-version of ASCOT4/JINTRAC is foreseen to be available later this year.

2. After fixing some minor bugs in ASCOT4, it produced similar results to those of ASCOT3 for the MAST plasma used for testing outside JINTRAC.
3. The first full JINTRAC+ASCOT simulation of a MAST plasma was performed using the magnetic background from EFIT. Fully predictive simulations including the time evolution of the magnetic field proved to be problematic due to the lack of a suitable equilibrium code inside JINTRAC; CREATE-NL does not work for MAST and a simpler equilibrium code ESCO is unable to provide the magnetic field outside the last closed flux surface and is, consequently, not compatible with ASCOT. After fruitful discussions with Dr. G. Corrigan and Dr. M. Romanelli we came up with some ideas how we might be able to circumvent the problem, but did not have the time to try them out as they involve a substantial amount of code development.
4. The benchmark between the three codes and their different models (ASCOT-FO, ASCOT-GC, NUBEAM with and without Larmor correction, and LOCUST-GPU) is under way.

4.4.15 In situ LIBS measurements and study of tungsten coatings erosion at Magnum-PSI (1)

Names of seconded persons:	J. Karhunen, A. Lissovski, K. Piip
Sending institution:	UT (Lissovski, Piip), VTT (Karhunen)
Host institution:	FOM
Dates of secondment/missions:	16–28 June 2013 (Piip), 16–21 June 2013 (Lissovski), 23–28 June 2013 (Karhunen)

4.4.15.1 Work plan/milestones

1. Set up experimental system for *in situ* LIBS measurements
2. Expose samples to Magnum-PSI plasma
3. Perform *in situ* LIBS measurements in Magnum-PSI TEAC chamber
4. Record tungsten emission on samples surface during plasma exposure

4.4.15.2 Report

This visit was related to the active collaboration between the FOM Institute DIFFER and Tekes (research units VTT and University of Tartu) in the field of plasma-surface interactions. The main research themes within this collaboration are (i) studying erosion and changes in surface morphology of ITER-relevant materials when exposed to high-flux plasma discharges and (ii) developing laser induced breakdown spectroscopy (LIBS) an *in situ* diagnostics tool for ITER.

Milestone 1: During the beginning of the visit LIBS system was set up to perform *in situ* measurements in Magnum PSI target exchange and analyzes chamber (TEAC). Main components of the system were Nd:YAG laser that generates pulses at 1064 nm; mirrors and lens to guide laser beam to TEAC and focus on the target (beamline length approximately 30 m); $f = 30$ cm lens to image the LIBS plume to the end of optical fiber; fibers to guide the light to spectrometer; spectrometer with spectral range around 60 nm and CCD camera with image intensifier.

The system was installed and the components were aligned. Spectrometer was adjusted to spectral range 370–430 nm. In that range there are several strong spectral lines of W, Mo and Al.

The system was tested and optimized first with atmospheric pressure in TEAC and then at pressure around 10^{-4} Pa. Different delay times between laser pulse and CCD triggering and detection gate widths were tested.

Milestone 2: Altogether four samples were exposed to plasma in Magnum-PSI. In each case, the plasma was a mixture of helium and deuterium with volumetric He:D ratio of approximately 60:40. The profile of the plasma beam was Gaussian. Three of the samples were based on a molybdenum substrate with 2 μm thick coatings of either pure tungsten or a mixture of tungsten and aluminium – the latter simulating beryllium – with an atomic W:Al ratio of 90:10. The remaining sample was bulk molybdenum.

The first pure tungsten sample was used to find the plasma parameters that were suitable for the experiments. The sample was exposed to a number of plasma discharges with durations of 8 s and 25 s, adding up to a total exposure time around 100 s. In these first discharges, the FWHM of the plasma beam was 20–25 mm, and the sample was not biased. This resulted into surface temperatures with also Gaussian profiles, peaking at around 950 °C according to IR camera. Such conditions were not able to induce significant visual changes on the surface of the sample.

The second sample was a mixture of tungsten and aluminium. To induce more effect on the surface, the target was now biased to -30 V, increasing the peak surface temperature to 1000 °C, and the exposure time was extended to 350 s, consisting primarily of 25-s discharges. This time, clearly visible changes could be observed on the surface of the sample.

The third sample was again pure tungsten and biased to -30 V. To increase the surface temperature, the FWHM of the plasma beam was narrowed down to 12–15 mm by applying stronger magnetic confinement, resulting in peak temperatures of about 1500 °C. After several 12-s discharges, totalling at around 190 s of plasma exposure, significant changes on the sample surface were observable.

The bulk molybdenum sample was used as a reference for studying erosion with the help of tungsten line emission. The plasma conditions were kept similar to the ones for the third sample, but the exposure time was only 35 s.

Milestone 3: A LIBS system had been set up earlier in connection with the Magnum-PSI to enable performance of LIBS studies in *in situ* fashion in between plasma exposures without breaking the vacuum. The set-up consisted of a pulsed Nd:YAG laser, operating at 1064 nm, whose beam was led into the target ex-

change and analysis chamber (TEAC) of the Magnum-PSI device and focused on the sample such that the diameter of the laser spot on the sample was approximately 0.8 mm. The light emission was focused on an optical fibre, transmitting the light to a spectrometer, and recorded by a CCD camera with an image intensifier. The spectral region of the spectrometer was set to 370–430 nm to catch the most intense tungsten and molybdenum lines. To decrease the background continuum, a delay at around 300 ns was set between the laser pulse and the onset of recording. The recording itself lasted for 4 μ s.

The first pure tungsten sample was used for testing of the LIBS set-up and establishing the measurement parameters. For the second and third samples, measurements were done in situ fashion from six different sites on the sample surface after the total plasma exposure at pressures around 10^{-4} Pa before venting the machine. Due to the diameter of the samples being larger than that of the plasma beam, some of the ablation sites were on almost unexposed surface area, whereas others were in the region of plasma exposure, enabling comparison between results from exposed and unexposed coatings.

For each site, spectra were recorded from 40 successive laser shots. The preliminary results show a decrease in the tungsten signal with increasing shot number and a corresponding increase in the substrate molybdenum signal, as expected. However, no noticeable differences were seen in the depth profiles obtained by LIBS from exposed and unexposed areas.

Milestone 4: Fast visible camera equipped with a filter with a peak transmittance at 400.8 nm was used to study erosion of tungsten during a plasma discharge by focusing the camera on the surface of the sample and recording tungsten line emission at 400.9 nm. The recording rate of the camera was 500 frames/s.

Tungsten emission was recorded for the third sample, and a reference background signal was obtained using the fourth, bulk molybdenum, sample. The preliminary results show a clear increase in the tungsten emission during the plasma discharge.

4.4.16 Verification and validation of RH system requirement using Digital Mock-ups (1)

Name of seconded person:	R. Sibois
Sending institution:	VTT
Host institution:	FOM
Dates of secondment/missions:	24 June – 19 July 2013

4.4.16.1 Work plan/milestones

The RH task for which the EFDA GOT trainee has been assisting with, is the remote handling (RH) analysis of an ITER Hot Cell Facility (HCF) maintenance procedure which consists of the extraction and the insertion of the Mirror M3 assembly of the ITER Electron Heating & Current Drive Upper Launcher (EH&CD UL).

The EH&CD UL is located in 4 of the ITER Upper Port Plugs. Its optical configuration consists of mm-wave beams entering each of the 4 UL through waveguides into the vacuum vessel. Each beam is then directed to the plasma using serial arrangement of 4 mirrors. To be maintained the focusing mirror M3 has to be extracted from and inserted into the UL Flange.

The goals of the visit are:

1. Study UL with mirror assembly design
2. Define the environment and constraints
3. Propose a conceptual approach for the mirror M3 insertion/extraction procedure
4. Perform a verification and validation of the conceptual approach using Digital Mock-ups
5. Perform a feasibility study of the concept using Virtual Reality (VR, real-time physics simulation)
6. Compare the dynamic effects / effects of bending of the Digital Mock-up with those of the Virtual Reality.

and the expected outputs:

1. PDF: The UL and M3 assembly in the HCF
2. TDF: The insertion/extraction procedure of the mirror M3 in the UL
3. OSD: The step by step insertion/extraction procedure of the WGA in the UPL
4. VR animation
5. A report on the verification and verification results including comparison to VR.

4.4.16.2 Report

The trainee was introduced with all aspects of carrying out the RH compatibility assessment. Emphasis was put on preparing the CAD models for the simulation and the realisation of the simulation itself. The trainee has been furthermore encouraged to apply his knowledge and previous experience to verify and validate the remote handling tooling and procedures and to make suggestions to improve overall performance of the task execution.

Performed activities:

- Studying the M3 new design
- PDF has been written
- TDF has been written
- RH sequences defined
- Getting familiar with 3ds Max and PhysX
- Physical modelling of the M3 assembly
- VR testing video outputs
- Went through all the different aspects of the RH approach.

The four weeks dedicated to this mobility period showed to be a very short time for such tasks. The most time consuming phases of this procedure were to get familiar with the tools according to the expected outputs.

It has been a very fruitful experience by getting new knowledge on different ITER aspects. It was very interesting to work within a different team which may have a different angle of view on RH aspects. New techniques have been used, new perspectives have been discovered and a new way of working has been experienced during this mobility period.

4.4.17 Effect of impurities on the plasma flow

Name of seconded person: S. Leerink
Sending institution: AU
Host institution: Chalmers University of Technology
Dates of secondment/missions: 24–26 June 2013

4.4.17.1 Work plan/milestones

Recent gyrokinetic simulations of ohmic FT-2 tokamak discharges, performed with the full-f PIC code ELMFIRE, have shown a clear effect of the impurity fraction on the poloidal $E \times B$ flow. When the radial gradients of the density and temperature are rather steep, as is the case in FT-2 plasma discharges, a poloidal variation in the impurity density will arise due to the ion-impurity friction. This variation leads to a substantial change in the plasma flow. Analytical work that describes the influence of the impurities on the plasma flow has been derived for various collisional regimes [3]. A scan of the collisional regimes has been performed with the Elmfire code and a good agreement has been obtained for the plateau regime. For the Pfirsch-Schlütter regime however the results are less promising and a discrepancy to the analytical work was found.

During this mobility visit the focus will be on understanding this difference. Furthermore there is the question on how to treat the transition between the plateau and Pfirsch-Schlütter regime.

4.4.17.2 Report

The rotation results from gyrokinetic impurity simulations of ohmic FT-2 tokamak discharges, performed with the full-f PIC code ELMFIRE were discussed. When the radial gradients of the density and temperature are rather steep, as is the case in FT-2 plasma discharges, a poloidal variation in the impurity density will arise due to the ion-impurity friction which can lead to a substantial change in the plasma flow.

The simulations were compared against the analytical work by [M. Landreman and T. Fülöp, Phys. Plasmas **18** (2011) 092807] which took the influence of the impurities on the plasma flow in the presence of steep gradients for various collisional regimes. A good agreement was found for the plateau regime. For the

Pfirsch-Schlütter regime however the results are less promising and a discrepancy to the analytical work was found. It turned out to be unclear whether the change in the plasma flow and poloidal variation in the impurity density were caused by the density and temperature gradients, as the profiles might not be steep enough to be the main contributor to the observed discrepancy. It might be that even with less steep profiles the variations in the poloidal direction will appear if the impurity fraction is large enough. In the latter case it should be possible to find a good agreement with the analytical work used in [Y.B. Kim et al., Phys. Fluids B **3** (1991) 2050]. To clarify this, a scan of the profile gradients will be performed with the Elmfire code.

4.4.18 SOLPS modelling of the inner divertor of ASDEX Upgrade

Name of seconded person: L. Aho-Mantila
Sending institution: VTT
Host institution: IPP Garching
Dates of secondment/missions: 28 July – 10 August 2013

4.4.18.1 Work Plan/milestones

The inner divertor of ASDEX Upgrade features a fluctuating behavior and a density blob formation under detached conditions. Presently, numerical codes cannot reproduce these observations, as the underlying physics is not yet understood. During this visit, Leena Aho-Mantila will present modelling results for the first, non-fluctuating state of detachment. In particular, the modelled density distribution in the inner divertor is compared with experimental density measurements using the Stark broadening method. The origins of divertor in-out asymmetries in low-density plasmas will be analysed using existing SOLPS solutions.

Goals:

1. Discussion of recent progress in SOLPS simulations with the code developers. Presentation of observed convergence times and time step limitations.
2. Participation in an informal meeting on the observations relating to the high-field-side density blob in ASDEX Upgrade discharges. Presentation of modelling results.
3. Further comparisons between simulations and Stark broadening measurements by Dr. Steffen Potzel.
4. Analysis of modelled in-out asymmetries in ASDEX Upgrade low-density discharges.

4.4.18.2 Report

Goal 1: A presentation was given in a SOLPS expert meeting held in Garching describing the recent observations of simulation convergence times when modelling N-seeded discharges.

Goal 2: A presentation was given showing the most recent comparisons of modelled and measured density distributions in the inner divertor volume of ASDEX Upgrade. Possible discrepancies between target Langmuir probe and spectroscopic measurements were pointed out, requiring further investigations. The influence of impurities on the fluctuating detachment state was discussed based on modelling results.

Goal 3: Steps needed to generalize the synthetic diagnostic in SOLPS and comparisons with experimental Stark broadening measurements were discussed with Dr. S. Potzel, and the SOLPS part of the analysis routines was developed further.

Goal 4: Due to long convergence times, the simulations of discharges with the lowest density levels had to be run further and detailed analysis of the results will be performed at a later time.

4.4.19 Power exhaust studies with JET-ILW for model validation (1)

Name of seconded person: L. Aho-Mantila
Sending institution: VTT
Host institution: EFDA JET
Dates of secondment/missions: 11–24 August 2013

4.4.19.1 Work Plan/milestones

The purpose of this visit is to analyse power exhaust by participating in the relevant experimental studies in JET. Because of the all-metal wall, intrinsic impurities do not lead to high radiated power fractions in the divertor, but the injection of external impurities is needed to exhaust the SOL power via radiation. Several experiments are planned in the C31 campaign to characterize impurity-seeded plasmas. Leena Aho-Mantila will take part in the preparation, coordination and analysis of these experiments and perform interpretive simulations for carefully selected discharges using the SOLPS code package. The work constitutes a significant part of Aho-Mantila's 2013–2014 EFDA fellowship project.

Based on the experimental timeline, the participation in the C31 campaign has been divided into two visits. This first visit has the following specific goals:

Goals

1. Participation in the detailed planning of the main experiment M13-14: "Establish stationary seeded H-mode (N_2 or Ne)" in collaboration with the scientific coordinator C. Giroud (L. Aho-Mantila is the deputy SC).

2. Participation in the analysis of power exhaust physics in the first session of the main experiment M13-17: "Impurity seeding to max frad" (L. Aho-Mantila is a member of the scientific team).
3. Continuation of the analysis of the back-up experiment Bx-1.3.1: "Seeded L-mode studies" (L. Aho-Mantila is the SC). Detailed comparisons between available diagnostic signals (in particular spectroscopy) and SOLPS simulations.
4. Further preparation of the back-up experiment B13-01: "N₂ seeded L-mode studies" (L. Aho-Mantila is the SC).

4.4.19.2 Report

Goal 1: L. Aho-Mantila participated actively in the planning of the experiment M13-14. She gave input in particular to the requirements of diagnostics specification for modelling purposes and prepared power exhaust -related inter-shot analysis steps.

Goal 2: L. Aho-Mantila participated in the inter-shot analysis of the first session of M13-17 by providing estimates of divertor cooling during the discharges.

Goal 3: L. Aho-Mantila started to work on building synthetic diagnostics in SOLPS to represent various spectroscopy systems and bolometry measurements in JET.

Goal 4: Plans for the back-up experiment B13-01 were further developed to accommodate present diagnostic availability.

4.4.20 Gyrokinetic full f multiscale transport studies of Ohmic Textor discharges

Names of seconded persons: S. Leerink, T. Kiviniemi

Sending institution: AU

Host institution: FZ Jülich

Dates of secondment/missions: 19–23 August 2013

4.4.20.1 Work plan/milestones

Recently, ELMFIRE has been used to simulate ohmic discharges of the middle-sized tokamak TEXTOR. The gyrokinetic simulations showed strong GAM oscillations in L-mode plasmas while with the H-mode parameters oscillation was much weaker. During this visit an detailed plan for the code validation will be made where the turbulence fluctuation level and temporal and spatial correlation as well as the the phase shift of GAMs will be compared.

4.4.20.2 Report

During the 4 day visit the following topics were discussed:

- The small difference in the phase of the correlation between E_r and the transport coefficients could be consistent with the predator-prey model (the GAM takes its energy from background turbulence and then background turbulence takes it back from GAM). A quantitative comparison of the phase differences could provide more insight.
- It was pointed out that the BDT criterium is not most relevant factor when looking at shear due to GAMs but one should rather use the criterium for effective shear due to the oscillating E_r as explained in [Hahm *et al.*, Phys Plasmas **6** (1999) 922].
- The typical turbulence correlation time in Textor is 10–20 μs . The radial propagation velocities of the GAM are of the same order in the Elmfire simulation as what they measure in the experiment. It is of interest to see how the radial propagation velocity of GAMs depends on the density. At Textor it was measured that the $v_{r,GAM}$ decreases with increasing density, see [Xu *et al.*, PPCF **53** (2011) 095015]. Elmfire simulations could be used to illustrate such a behaviour.
- It is of interest to perform a density scan to determine the dependence of the GAM and zonal flow amplitude as a function of isotope. In Textor it was measured that $A_{GAM}(D) > A_{GAM}(H)$ [Xu *et al.*, PRL **110** (2013) 265005].
- A discharge for quantitative validation of the Full-f gyrokinetic code ELMFIRE to experimental measurements of density fluctuations and correlation lengths has been chosen.

4.4.21 In situ LIBS measurements and study of tungsten coatings erosion at Magnum-PSI (2)

Names of seconded persons: A. Lissovski, K. Piip
Sending institution: UT
Host institution: FOM
Dates of secondment/missions: 22–31 August 2013

4.4.21.1 Work plan/milestones

1. Check and align the system for in situ LIBS
2. Expose samples to Magnum-PSI plasma using the ELM-like plasma regime
3. Perform in situ LIBS measurements in Magnum-PSI TEAC chamber
4. Record tungsten emission on samples surface during plasma exposure.

4.4.21.2 Report

This visit was continuation of the experiments carried out in June.

Milestone 1: In the beginning of the visit, the LIBS system, that was set up during the previous visit in June, was checked and aligned to perform *in situ* measurements in Magnum PSI target exchange and analyzes chamber (TEAC). Main components of the system were Nd:YAG laser, that generates pulses at 1064 nm; mirrors and lens to guide laser beam to TEAC and focus on the target (beamline length approximately 30 m); $f = 30$ cm lens to image the LIBS plume to the end of optical fiber; fibers to guide the light to spectrometer; spectrometer with spectral range around 60 nm and CCD camera with image intensifier.

The spectrometer was adjusted to spectral range 405–465 nm. In that range there are several strong spectral lines of W and Mo. This milestone was reached.

Milestone 2: Three samples were exposed to Magnum PSI plasma. All the samples were exposed to He/D₂ plasma with He content around 60% (by volume).

All three samples were exposed to plasma in pulsed-steady mode using 11 s shots. To achieve pulsed-steady mode, capacitor bank was used.

The first sample was 2 μm thick W coating on Mo substrate. The sample was exposed to plasma for approximately 200 s in total. The sample was not biased. Plasma beam had Gaussian profile with FWHM 12–15 mm. Peak temperature at the sample surface was around 1100°C and had also Gaussian profile according to IR camera. During capacitor bank pulses temperature was about 100 degrees higher.

The second target was identical to the first one. It was exposed to plasma for 100 s. Experimental conditions were the same as for the first target, but it was biased with -40 V. The third sample was bulk Mo. This sample was exposed to use it as a reference for erosion studies using W 400.9 nm line emission on target surface. Three 11 s shots of plasma exposure were used on this target. Experimental conditions were identical to the ones used for the first and second target. This milestone was reached.

Milestone 3: *In situ* LIBS measurements in the Magnum PSI TEAC chamber were performed for two samples. For the first and second sample *in situ* LIBS measurements were performed from 6 and 8 different sites on the sample, respectively. Some of the sites were in the region exposed to plasma and some in the nearly unexposed region. For each site 60 spectra were recorded. During the measurements the pressure in the TEAC was around 10^{-4} Pa and between plasma exposure and LIBS measurements the samples were not in contact with air. Preliminary data processing revealed that for spectra recorded from one site intensity of W lines decreased and Mo lines increased with laser shot number, as it was expected. For the sites in the region exposed to plasma there were some changes. This milestone was reached.

Milestone 4: To study W erosion during plasma exposure a fast visible camera with a suitable filter was used. The peak transmittance of the filter was at 400.8 nm, close to W strong spectral line at 400.9 nm. The camera was focused to the sample surface.

During plasma exposure of all the three samples the camera recorded 5000 frames per second. The exposure time was 100 μs . This milestone was reached.

4.4.22 Power exhaust studies with JET-ILW for model validation (2)

Name of seconded person: L. Aho-Mantila
Sending institution: VTT
Host institution: EFDA JET
Dates of secondment/missions: 1–28 September 2013

4.4.22.1 Work Plan/milestones

Based on the experimental timeline, the participation in the C31 campaign has been divided into two visits. This second visit has the following specific goals:

Goals:

1. Participation in the coordination and analysis of the first four sessions of the main experiment M13-14: "Establish stationary seeded H-mode (N_2 or Ne)" (L. Aho-Mantila is the deputy SC).
2. Participation in the analysis of power exhaust physics in the third session of the main experiment M13-17: "Impurity seeding to max frad" (L. Aho-Mantila is a member of the scientific team).
3. First assessment of differences observed in the trends of power exhaust in L-mode (Bx-1.3.1, B13-01) and complex H-mode plasmas (M13-14, M13-17).
4. Continuation of the analysis of the back-up experiment Bx-1.3.1: "Seeded L-mode studies" (L. Aho-Mantila is the SC). Detailed comparisons between available diagnostic signals and SOLPS simulations.
5. Possible modifications to the experiment plan for B13-01: " N_2 seeded L-mode studies" (L. Aho-Mantila is the SC), based on the outcome of related experiments and diagnostic availability.

4.4.22.2 Report

Goal 1: L. Aho-Mantila participated as a deputy SC in the experiment execution of M13-14.

Goal 2: L. Aho-Mantila performed inter-shot analyses of the divertor radiative cooling in the M13-17 experiment by analysing the combination of Langmuir probe and bolometry measurements.

Goal 3: First analyses showed that similar divertor regimes could be obtained in the H-mode experiments compared to the L-mode experiments, but significant differences were observed in the radiation distribution. The H-mode experiments had pronounced radiation in the X-point region, and suffered from core radiation due to sputtered W.

Goal 4: L. Aho-Mantila presented the comparisons between synthetic diagnostics and experimental measurements at the TFE1/E2 meeting. Selected spectroscopic measurements and Li-beam data were reanalysed by the responsible officers to

achieve better quality profiles. L. Aho-Mantila modified the simulation set up to include a more detailed wall definition, which previously was not available, and rerun the simulations of Bx-1.3.1.

Goal 5: The experiment plan of B13-01 was updated, but no experimental time was given to this experiment.

4.4.23 Remote handling system analysis

Name of seconded person: P. Alho
Sending institution: TUT
Host institution: EFDA JET
Dates of secondment/missions: 2 September – 25 October 2013

4.4.23.1 Work plan/milestones

The goal of the visit is to develop RH fault taxonomy that could be used to support failure analyses and implementation of fault tolerance solutions. Pekka Alho has been developing fault tolerant control system architectures for ITER in GOT RH. Fault tolerant software has been designed to provide service in spite of errors, e.g. with a subset of functionality. However, implementation of fault tolerance is typically very domain specific subject and depends on availability of fault classifications. Currently there are no fault taxonomies for RH publicly available. RH fault taxonomy could be used to develop methods for fault detection, isolation, and mitigation specific to RH domain. ITER related research on RH control systems would therefore benefit from this approach. A fault taxonomy could be developed by analysing real operational data (bottom-up approach) and control system architecture e.g. for boom controllers.

Milestones:

- Create an initial version of taxonomy before the visit
- Collect qualitative and quantitative data from available failure analyses, RH maintenance data, deviations caused by faults and analysis RH of control system architecture
- Subjective data collection based on expert interviews
- Evaluate recent control system architecture using the taxonomy
- Improvement of the taxonomy based on real-world results.

4.4.23.2 Report

The main goals for the mobility were to gain more insight in the complexity of real RH maintenance and development of RH fault taxonomies based on available operational data and failure logs. In addition to achieving these goals and the

milestones listed in previous section, initial architecture and fault tolerance of Mascot 6 control system architecture were reviewed.

Key achievements of mobility:

- Gaining an understanding of the Mascot control system architecture
- Gaining understanding on problems related to running and maintaining complex RH equipment that in many ways is prototypical in nature
- Recommendations for Mascot control system fault tolerance
- Several fault taxonomies for RH systems were developed
- A presentation about the mobility topic and EFDA GOT-RH was given 18 October for CCFE's remote handling group under the topic "Software fault tolerance and dependability issues for RH like control systems".

4.4.24 RAMI requirements for RH equipment

Name of seconded person: J. Väyrynen
Sending institution: TUT
Host institution: EFDA JET
Dates of secondment/missions: 2 September – 25 October 2013

4.4.24.1 Work plan/milestones

The goal of the work package is to study the RH equipment RAMI requirements and evaluate a set of equipment against the requirements through qualitative and quantitative methods. Furthermore, based on the evaluation, the goal is to create a scheme with which the RAMI requirements could be met, and based on the concept scheme, to create a process for building reliability in further ITER RH equipment development. A previously developed method has been tested against an ITER-relevant complex target. Furthermore, work on addressing reliability of controllers is planned. This should address both the hardware and software aspects of controller systems, and related work could be performed at JET. Often in the RAMI process, software is overlooked – not least because the amount of different failures software can encounter and cause. A method applied in this work package strives to address this oversight through probabilistic approach. While it must be admitted that technically software failures are deterministic in nature, they can appear as purely stochastic phenomenon for the end user. Following this line of thought, the probabilistic approach could be used to address the controller software reliability. The method that has been applied to system hardware could – in theory – be used with software, and the enveloping requirements divided to the software modules. This, in addition to supplying more concrete numerical requirements to the software module coders, would allow the use of top-level controller requirements, or allocations, as a part of the entire system reliability assessment

as the software has – hopefully – been verified to the requirements allocated to them. Alternatively, the RAMI requirements of an RH device could be analysed. Based on the analysis, a COTS component/system level allocation could be made on the RH device or piece of equipment. This allocation could be compared with real life failure/maintenance data gathered during the JET maintenance operations. This would yield information on validity of the applied method and whether the component/system RAMI performance corresponds with the requirements. Furthermore, based on the allocations a reliability/maintenance simulation could be done, the results of which could yield information on more optimised RH equipment maintenance regime, if such is desired.

Goals of the visit:

- Assess the applicability of the developed method on analysing and addressing software reliability

or

- Analyse the reliability requirements and the component level reliability of a piece of RH equipment and assess the possibility of optimising the maintenance scheme.

Detailed actions

- Analyse the requirements set to the RH controller system
 - Allocate module level requirements for software
 - Compare the allocation with the runtime data from the real life system
- or
- Analyse the RAMI requirements set to an RH device
 - Allocate COTS-level requirements for the system
 - Compare allocation with runtime data from the real life system.

4.4.24.2 Report

Initially a RAMI model of an RH system was created and a module level allocation performed on the system. To compare this model against real life reliability of the system, failure and maintenance data was collected from the maintenance logs. This data was transformed into more usable form of statistics that could be used to compare the initial allocations against the data from the maintenance operations. Using this data, the initial allocations were updated.

As further data was available, it was analysed and compared against the updated allocations.

4.4.25 Erosion and retention investigations of ASDEX Upgrade marker tiles and probes (2)

Name of seconded person: A. Hakola
Sending institution: VTT
Host institution: IPP Garching
Dates of secondment/missions: 9–20 September 2013

4.4.25.1 Work plan/milestones

1. Rutherford Backscattering Spectroscopy (RBS) measurements of AUG wall tiles
2. RBS measurements of one erosion probe
3. Organizing a monitoring meeting for the EFDA ITER Physics project WP13-IPH-A01-P3

4.4.25.2 Report

Milestone 1: This milestone dealt with RBS analyses of 14 marker tiles, removed from different toroidal and poloidal locations of the central heat-shield region of AUG in April 2013. Half of the tiles had a 2- μm thick P92 steel coating while the rest were equipped with 1.5–2 μm thick, equally wide toroidal W and Ni marker stripes on graphite. The tiles had been exposed to plasma during the entire 2012/13 experimental campaign of AUG, except for three P92-coated tiles (from the NBI shine-through region) which had been in the vessel only since September 2012. To determine erosion of the markers, the RBS results will be compared with the corresponding data extracted from the tiles before their plasma exposure in 2011 and/or during the intermediate intervention in August 2012.

The analyses were made in the accelerator lab of IPP using the Bombardino analysis chamber. In the measurements, protons with an energy of 3.0 MeV were used, and the energy spectrum of the backscattered particles at 165° was detected. The step between adjacent measurement points along each marker stripe in the toroidal direction was 10–20 mm.

Qualitatively the results indicate that little erosion has taken place while many of the tiles show a relatively thick boron-rich deposited layer. Only the three tiles from the NBI shine-through region show signs of strong erosion or of otherwise damaged surface. Quantitative picture on the erosion/deposition behaviour will, however, be obtained only after the measurement data have been carefully analysed in late 2013.

All the planned measurements were carried out and this milestone was therefore reached.

Milestone 2: Another main goal of the visit was to analyse using RBS one marker probe that was exposed to low-power H-mode plasma discharges in AUG

in January 2013. The probe had four 5 mm wide, 30–50 mm long, and 50–100 nm thick marker stripes. The distance between the stripes was approximately 5 mm on an oval-shaped surface, tilted by 45° from the horizontal reference plane; This allowed one to study not only erosion of the markers but also re-deposition of the eroded material. The materials of the marker stripes were carbon (in the form of diamond-like carbon, DLC, with a thin intermediate layer of tungsten), aluminium, nickel, and tungsten.

In the measurements, 2.0 MeV $^4\text{He}^+$ ions were used, and the step between adjacent measurement points along each marker stripe (including the uncoated ones) was approximately 3–5 mm. The erosion profiles of the markers will be determined by comparing the RBS results with the corresponding data measured before the probe experiment in August 2012.

All the planned measurements were carried out and this milestone was therefore reached.

Milestone 3: A monitoring meeting of the EFDA ITER Physics project WP13-IPH-A01-P3 was arranged in 11–12 September, 2013, together with the projects WP13-IPH-A01-P1 and WP13-IPH-A01-P2. Altogether 10 (out of 16) participants reported the progress of their tasks either remotely or in person in Garching. The presentations will become available in the ITER Physics users wiki page. The milestone was reached

4.4.26 Validation of SOLPS simulation results against ASDEX Upgrade diagnostic data

Name of seconded person:	L. Aho-Mantila
Sending institution:	VTT
Host institution:	IPP Garching
Dates of secondment/missions:	29 September – 20 December 2013

4.4.26.1 Work Plan/milestones

Detailed comparisons with diagnostic measurements are required to validate the numerical solutions of the scrape-off layer and divertor plasma. During this mobility visit, the comparisons between the SOLPS solutions for the series of benchmarking experiments in 2013 and diagnostic data will be extended to include detailed spectroscopic and bolometer measurements. The investigated ASDEX Upgrade discharges have been carried out in both normal and reversed field configurations with or without N-seeding. The solutions will be further developed taking into account the new benchmarking results.

Goals

1. Comparison of simulation results with bolometer measurements along individual lines-of sight.

2. Comparison of simulation results with spectroscopic measurements of deuterium and nitrogen line emissions.
3. Further SOLPS simulations to test assumptions related to the bolometer and spectroscopy results.
4. Presentation of the current status of model validation for N-seeded discharges in the E2M programme seminar in Ringberg.
5. Preparation of an abstract of the work for the 2014 PSI conference together with the IPP co-authors.

4.4.26.2 Report

Goal 1: Calculation of radiation along the lines-of-sight used in the 2013 experiments was performed for the SOLPS solutions. It was observed that, after a correction in the diagnostic measurements was implemented during the campaign, a better agreement with the simulation results could be achieved. In general, the radiation distribution between the core and divertor plasma regions could be reproduced in the simulations, but some discrepancies were observed when analysing the divertor measurements in detail. The comparison was done in collaboration with the bolometer responsible officer M. Bernert.

Goal 2: Calculation of spectroscopic emission along the lines-of-sight used in the 2013 experiments was performed for the SOLPS solutions using ADAS data. The lines investigated were the deuterium alpha–delta Balmer lines and several NII and NIII lines within the wavelength range of these Balmer lines. The initial comparison revealed discrepancies up to a factor of 4 between the modelled and measured emissions. However, inconsistencies were also observed between the present experimental data and data obtained from earlier campaigns. Work continues in collaboration with Dr. S. Potzel to check the data evaluation routines.

Goal 3: Further SOLPS simulations are on-going to test assumptions on background impurities and their effect on the radiation measurements.

Goal 4: A presentation was given at the E2M programme seminar with the title “Simulating N-seeded discharges”.

Goal 5: An abstract was submitted to the PSI conference with the title “Validated model-based radiation scalings for the ITER-like divertors of JET and ASDEX Upgrade”.

4.4.27 Verification and validation of RH system requirement using Digital Mock-ups (2)

Name of seconded person: R. Sibois
Sending institution: VTT
Host institution: CCFE
Dates of secondment/missions: 14 October – 8 November 2013

4.4.27.1 Work plan/milestones

The RH task for which the EFDA GOT trainee has been assisting with, is the design activities of the DEMO remote maintenance system. It includes:

- Study the DEMO design activities
- Develop concepts for the In-Vessel Mover (IVM):
 - Deployment from the divertor cask
 - Deployment through the divertor port
 - Location in-vessel
 - Electric and hydraulics actuation of the mover arm
- Tool deployment and operation
 - Actuating twist-locks
 - Preload blanket springs
 - Inspection
 - Pipe handling
- Concept verification
- Operation duration estimates.

The expected outputs are:

- CAD models
- Report on the design activities
- Oral presentation for describing the solutions.

The trainee is invited to assist the RH design team at CCFE with producing the required set of outputs. The trainee will be introduced with the design activities performed within CCFE. The trainee is furthermore encouraged to apply his knowledge and previous experience to verify and validate the RH procedures and to make suggestions to improve overall performance of the task.

4.4.27.2 Report

Performed activities:

- Study the DEMO design activities
- Develop concepts for:
 - Deployment from the divertor cask

- Deployment through the divertor port
- Location in-vessel
- Electric and hydraulics actuation of the mover arm
- Tool deployment and operation
 - Actuating twist-locks
 - Preload blanket springs
 - Pipe handling
- Concept verification
- Study the rack and pinion solution for DEMO Divertor Cassette Mover.

The four weeks dedicated to this mobility period showed to be a very short time for such tasks. It has been a very fruitful experience by getting new knowledge on different fusion project. It was very interesting to work within a different team which may have a different angle of view on RH aspects. New techniques have been used, new perspectives have been discovered and a new way of working has been experienced during this mobility period.

4.4.28 ASCOT-HAGIS benchmark

Name of seconded person: A. Snicker
Sending institution: AU
Host institution: IPP Garching
Dates of secondment/missions: 20–25 October 2013

4.4.28.1 Work plan/milestones

The purpose of this visit is to carry out detailed benchmark/validation study between fast particle tracing codes ASCOT and HAGIS. The input files for the simulations have already been discussed and gathered. Milestones for this visit are:

- Fine-tune the last input files for NTM perturbations
- Compare particle orbits with NTM perturbation
- Carry out the simulations
- If time permits, start to analyze the results.

4.4.28.2 Report

During the visit the beam particle orbits were compared with and with out the NTM perturbation. A lot of work was put to get the NTM perturbation to be identical in both codes, as they did not had possibility to use the same input data. After a careful comparison, particle orbits were found to match with enough accuracy.

Then the full simulations with ensemble of particles were launched to compare the density depletion caused by the NTM perturbation. The simulations were carried out and the results were compared. It was clear the quantities that were compared were not the same for both of the codes. After quite a bit of work, the output

was standardized to enable the meaningful comparison. With proper output, also the density depletion was successfully benchmarked and the most important milestone for the visit was reached.

4.4.29 Investigation of properties of Jet ITER-like wall (ILW) samples using laser-induced breakdown spectroscopy (LIBS)

Name of seconded person: A. Lissovski
Sending institution: UT
Host institution: VTT
Dates of secondment/missions: 28 October – 1 November 2013

4.4.29.1 Work Plan/milestones

1. Carry out LIBS analyses of surface layers from JET samples, originating from the inner part of the divertor; to measure the depth profiles for W, Mo, C, Be, O, and D
2. test the set-up of the measuring system using the fiber bundle
3. analyse of results, the comparison with SIMS profiles and the previously obtained data.

4.4.29.2 Report

The visit is made as the continuation of the collaboration between Tekes-VTT and University of Tartu in the field of LIBS diagnostics for Be-containing samples.

Milestone 1: During the first three days of the visit, experiments with 12 samples extracted from selected JET tiles that corresponded to JET operation period 2010–2012 were carried out. The emission spectra were recorded using an Andor SR750 spectrometer and an ICCD camera iStar, in the direction perpendicular to the laser beam and in the spectral range 300–790 nm. The delay between recording and the laser pulse was set to 100 ns and the width of the gate pulse to 500 ns. The experiments were done using fluence of 20 J/cm². The presence of H and/or D, O, W, Mo, Be and C was clearly observed in the emission spectra. The depth profiles of these elements, i.e., the behaviour of the spectral emission versus the laser shot number were plotted for each sample.

This milestone was reached.

Milestone 2: The second part of visit dealt with the set-up of the measuring system where the single fiber was replaced by the fiber bundle. The test experiments with the same Jet-samples were carried out. As the result, the optical signal increased more than in 10 times and resolution improved about 2 times. The decision is to order the similar fiber bundle for further experiments.

This milestone was reached.

Milestone 3: During the visit, the set of LIBS-data was received. The following data processing and comparison with SIMS profiles and the previously obtained data will be done at home university location during the current month.

4.5 Euratom and EFDA Fusion Training Scheme

4.5.1 EFDA goal oriented training in remote handling – GOTRH

EFDA GOT: WP10-GOT-GOTRH
Project Coordinator: J. Mattila, TUT
Euratom-Tekes Trainees: P. Alho, J. Väyrynen, TUT
R. Sibois, VTT
Euratom-Tekes Mentors: J. Mattila, TUT
T. Määttä, VTT

The aim of the EFDA's European Goal Oriented Training programme on Remote Handling (GOTRH) is to train engineers for activities to support the ITER project and the long-term fusion programme in European associations, the work of associates, Fusion for Energy, and the ITER organization and industry. The principal objective is to implement a structured, remote handling system design and development oriented training task that is carried out in a multidisciplinary systems engineering framework through the use of quality assurance processes related to Fusion for Energy tasks and the available documents, document templates, and ITER-relevant software products. Special emphasis is placed on a top-down approach with multidisciplinary consideration of design requirements related to reliability, availability, maintainability, and inspectability (cf. RAMI approach).

A key requirement for the success of a project as large as ITER is that a systematic and standardized approach is adopted to ensure the consistency of the design with the required performance. In its own part, the science and technology objective of this project is to develop common standards and tools for ITER design and development activities. Common standards and tools are necessary to guide ITER development while ensuring that ITER is properly designed to make it affordable to build, operate and maintain.

The GOT RH project serves as a practical level project for increasing the coherence within RH context of collaborative training project between 5 participating European associations with 9 trainees. Euratom-Tekes trainees finished the project in 2013 and rest of the trainees are expected to finish in 2014–2015.

List of participating associations and number of trainees:

- Association Euratom-Tekes, Finland (3)
- Association Euratom-CEA, France (2)
- Association Euratom-FOM, Netherlands (2)
- Association Euratom-KIT, Germany (1)
- Association Euratom-CIEMAT, Spain (1).

Jukka Väyrynen is the TUT trainee working on the work package (WP) 1.3 in GOT RH. Topic of the WP1 is remote handling procedures and tools. The goal of this particular project (WP1.3: RAMI requirements assessment of ITER remote handling equipment components for their future procurement and life-cycle management) is to study the ITER RH equipment RAMI requirements and evaluate a set of equipment against the requirements through qualitative and quantitative methods. The method presented for this project was tested against the requirements set for JET remote handling equipment and the reliability data produced therein.

Romain Sibois is the VTT trainee working on the WP 1.5. The objective of this project (WP1.5: Verification and Validation (V&V) of ITER RH System Requirement using Digital Mock-ups) is to enhance verification and validation methods, models and processes during the early design phases of ITER Remote Handling equipment. The project aims to find out and utilize the most useful and efficient V&V approach to fulfil the requirements of the concept design towards reducing physical testing and replacing some aspects by virtual testing and verification. The conceptual design phase has been performed and the developed concept method has been applied on selected test cases during two mobility periods. The final report of the WP 1.5 has been performed and all the deliverables have been delivered.

Pekka Alho is the TUT trainee working on the WP2.1. Focus of the WP2 is software and control systems. The main research objective for this project (WP2.1: Fault tolerant device control system architectures for ITER RH system) is development of a fault tolerant and dependable architecture for ITER remote handling systems. Prototype for the control system architecture was tested on an open source real time operating system used to control a commercial industrial manipulator. Implementation of WP2.1 was carried out as defined by the GOT RH task process.

5. Fusion for Energy and ITER Activities

5.1 ITER Divertor Test Platform (DTP2)

F4E Contract: F4E-GRT-143; F4E-GRT-401
Research scientists: M. Siuko, J. Järvenpää, T. Määttä, VTT
J. Mattila, TUT/IHA

The GRT 401 continues a long series of tests and development work of ITER divertor remote maintenance. During the years, the maintenance devices, processes and the reactor components have been developed. In addition, verification and validation methods for analysing the system with simulations, mock-ups and prototypes have been developed. A lot of valuable development work has been done which helps to find optimal design of critical components.

5.1.1 RH-trials on the exchange of the second divertor cassette

Since the divertor cassette and its locking system (CLS) have been modified substantially after the first set of handling and locking tests, the main RH-tasks were repeated. The modifications to the cassette affected most of the CLS tools, which were re-designed to meet the new interfaces and which will later have a large role when carrying the full cycle RH-trials of the cassette locking.

The tools designed for the locking operations are:

- Water hydraulic actuated jack handled by the manipulator arm. Designed for compressing and preloading the cassette. Compared to the previous version, the main differences are new interfaces of the cassette and the required compression force.
- Wrench tool for turning the heavy, ~450 kg cassette locking knuckle, (see Figure 5.1). The manipulator handled tool is hydraulically actuated, providing around 2 kNm torque. While turning the knuckle, the tool directs the counterforce to the cassette body.
- Pin tool for locking the knuckle to the cassette body and the knuckle to the reactor rail. The pin tool is actuated by an electric motor and rotates

threaded shafts of the locking pins by pushing the locking pins into their holes. The pin tool has an interface that directs the counterforce to the cassette body.

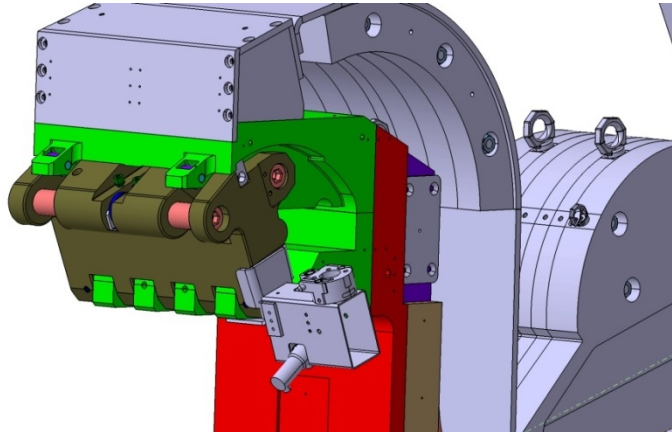

Figure 5.1. Wrench tool for turning the 450 kg cassette locking knuckle.

The operation of the locking sequence was tested in a lab environment. A mock-up with interfaces for the jack, wrench and pin tool was used to demonstrate the operation of the tools and the locking sequence.

The full locking sequence, done with the manipulator on CMM, will be done when the cassette is available after the CLS heat treatment test cycles.

5.1.2 RH-trials on the exchange of the central divertor cassette

The central cassette is the cassette at the end of the radial port, the first to be removed when entering the reactor. The central cassette is special due to its locking system. When the central cassette is installed, it is preloaded by hydraulic compression system and locked on both sides of the port with a component called Central cassette outer rail (CCOR). The central cassette itself is like any of the cassettes, and it is connected to CCOR through knuckles and locking pins.

The installation of the central cassette or any test prototypes have not been made before, so for starting the handling trials on DTP2, the central cassette end effector (CCEE) and the CCOR were re-designed.

The operation sequence and the CCOR design were developed by VTT together with IO and F4E. During the CCOR design process, various mechanical analysis and simulations were carried out.

The Central Cassette End-Effector CCEE is carrying the Cassette and CCOR and also the hydraulic compression system, see Figure 5.2. The CCEE design and manufacturing drawings were made by VTT and TUT.

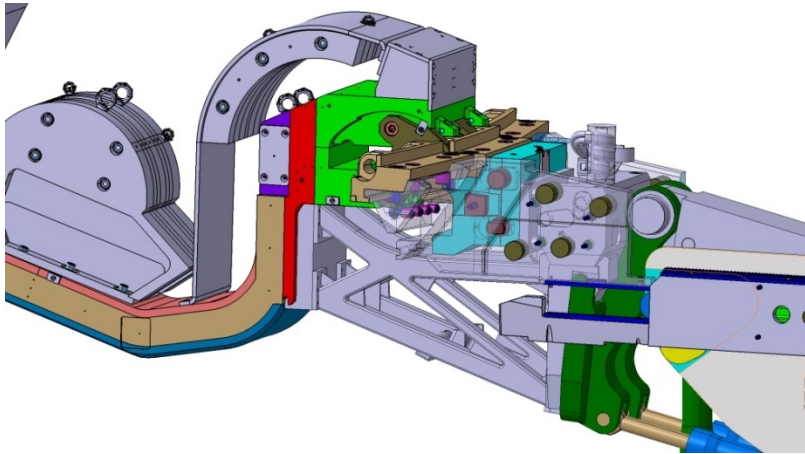

Figure 5.2. Cassette, CCEE and CCOR carried by the CMM.

The cassette compression and preloading unit used for the trials is simplified, manual version of the real one. The conceptual design is completed, while the design phase waits for the design of the CCOR.

5.1.3 Refurbishment of the DTP2 facility

To keep the DTP2 platform and systems in operation and updated for the next phase, some spare parts are purchased, like servo valves and hydraulic power unit components. Also, platform structure modifications of DTP2 are done for the next phase test operations.

The biggest modification for the platform is done to the reactor port to be able to carry the Central Cassette trials. The Central Cassette locking is done to the side plates of the reactor port, so called support pads. During the projects, the support pads were designed modular manner to allow possible future needs for modifications. This means that dedicated interfaces for CCOR were designed as replaceable inserts into more coarse lugs of the heavy support pad body.

5.2 Upgrade of the Divertor Cassette Mock-Up and verification of the Locking System – Part 2

ITER Contract: ITER/CT/12/430000674

Research Scientists: J. Järvenpää, H. Mäkinen, V. Hämäläinen, VTT

During the years, the divertor cassette has gone through several design cycles. Latest modifications were made to further develop the cassette locking against magnetic forces. See Yearbook 2012 for cassette manufacturing and assembly.

The largest changes were made to the outer cassette locking system (CLS) which was also the target in most of the tests. During the first test after assembly turning the knuckle and actuating the locking pins, problems were found on material pairs and locking mechanism design, which caused seizing of the pin-actuating mechanism. Due to the critical nature of the locking system, design modifications were made for the locking mechanism and the test programme was continued after that.

Then the Cassette locking system testing was continued. The initial operation of the CLS and the Cassette behaviour during then preloading and locking were recorded including geometrical deformation of the cassette, turning torque of the knuckle, operation of the locking pins and their winding shafts.

Then the CLS body with all the internal components was put into large furnace of a heat treatment factory. Heat treatment was done up to 350°C in vacuum (see Figure 5.3).



Figure 5.3. Cassette locking system after heat treatment in a vacuum furnace.

After the heat treatment, the operation of the locking mechanism was tested again. The idea was to compare the values to the initial ones before the heat treatment. After heat treatment, the tight clearances of latches were affected by the heat treatment so that turning the knuckle was no more possible with the planned methods.

Due to the findings, the locking mechanism requires more analysis and modifications required will be made. The test programme will be continued in 2014.

5.3 R&D/design of sensors for the ITER magnetics diagnostic: Design of the outer-vessel steady-state discrete sensor system

F4E contract: F4E-2010-GRT-156 (PMS-DG)

Research scientists: J. Kynäräinen, J. Saarilahti, H. Rimminen, VTT

Integrator drifts limit the accuracy of inductive sensors during long operating periods of the ITER fusion reactor. Steady-state magnetic sensors will be required to ensure sufficient accuracy of plasma position control. The goal of this activity is to develop detailed designs for a MEMS magnetics sensor system to be installed on the outer vessel of the ITER tokamak. The work includes the design and manufacturing of MEMS magnetometer sensors, their irradiation in a fission reactor, and environmental tests of the sensors mounted on a prototype sensor enclosure. Grant duration is 35 months.

Fabrication of the sensors has continued throughout 2013. Fabrication has been delayed by several equipment failures and by difficulties encountered due to previously untested processing steps. At the end of the year, wafer bonding efforts were continuing at VTT and at Fraunhofer IZM (Berlin).

Design of a stainless steel sensor enclosure has been continued (Figure 5.4). The sensors will be attached to ceramic substrates. Enclosures will be welded to outer skin of the vacuum vessel. FEM simulations were carried out to find mechanical and thermal stresses due to electromagnetic loads, radiation and temperature excursions.

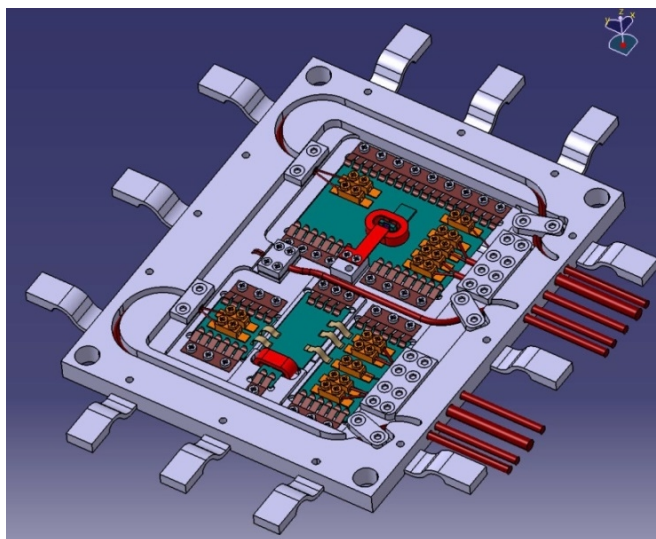

Figure 5.4. 3D model of the enclosure housing two MEMS sensors, one for the poloidal field component and one for the radial component.

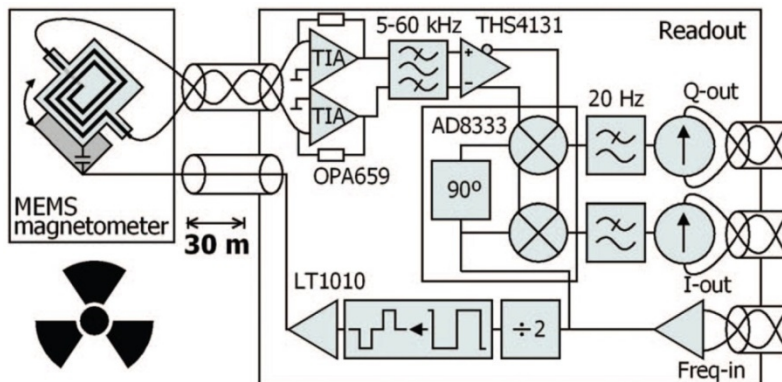

Figure 5.5. Block diagram of the implemented readout circuit. It will interface a control unit 100 m away in the diagnostics hall (not shown).

Tests in laboratory environment with previous generation MEMS sensors and prototype readout electronics (Figure 5.5) yielded 0.3 mT magnetic field resolution with 20 Hz measurement bandwidth. This meets the specified resolution of about 2 mT with some margin. Tests were carried out with 30 m long cables between the sensor and the preamplifier. The measurement principle is based on vibrating the sensor coil using electrostatic excitation and on measuring the induced voltage across the coil terminals.

5.4 Calculating the magnetization of ferromagnetic ITER components

F4E Contract: F4E-GRT-379
Research scientist: S. Sipilä, AU

Solving the magnetization of ferromagnetic components in ITER is a part of F4E grant GRT-379 “RIPLOS-2: Calculation of the TBM-Induced Ripple in ITER, Wall Loads, Impact on Plasma, and Optimization”. The main tool for this part of the project is the COMSOL Multiphysics finite element solver. The solved magnetic fields will be used in ASCOT for studies of fast ion wall loads.

In 2013, models of the relevant components of ITER have been optimized and imported into COMSOL from ITER CAD data and equilibrium data for a 15 MA discharge. These data include the plasma current density and models of the first wall, toroidal and poloidal field coils, ferromagnetic inserts (FI) for ripple mitigation, and the test blanket modules (TBM), shown in Figure 5.6. Meshing the geometry into finite elements for the magnetization calculation has been successful using simplified models for the FIs and TBMs, and optimization of the geometry and COMSOL model for producing the best possible magnetic field input for ASCOT is ongoing.

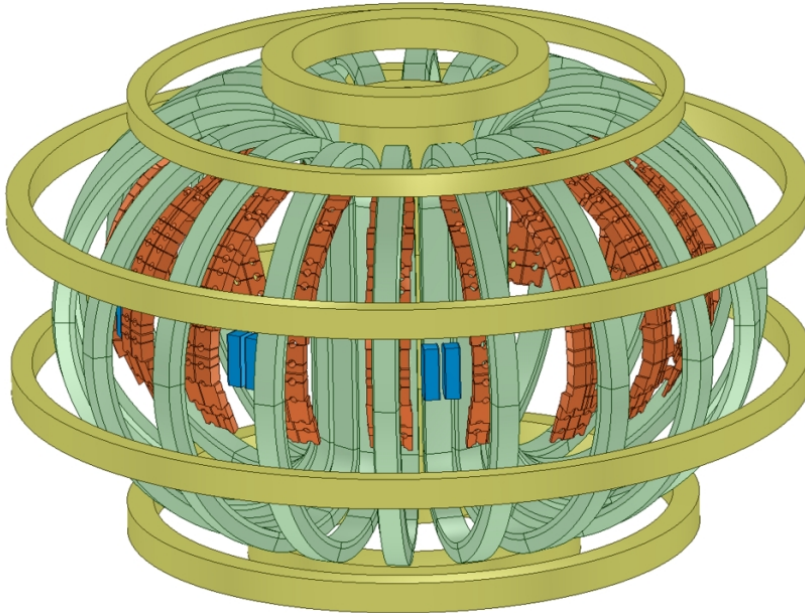

Figure 5.6. The relevant ITER components modelled in COMSOL Multiphysics. The magnetization of the ferromagnetic components – FI's (red) and TBM's (blue) – is solved using the known magnetic fields arising from the currents in the toroidal and poloidal field coils (green and yellow, respectively) and from the current in the plasma (not shown).

6. Other Activities

6.1 Conferences, workshops and meetings

J. Järvenpää participated in the EFDA WP12-DAS06-RH final review meeting, Garching, Germany, 31 January 2013.

27 participants in the EFDA TF-PWI Joint Working Session on Integrated Plasma-Wall Modelling, Tervaniemi, Finland, 4–6 February 2013. The session was organized by M. Airila and A. Hakola.

17 participants in the SimITER seminar, Tervaniemi, Finland, 6 February 2013. The seminar was organized by T. Kurki-Suonio.

M. Aints, A. Hakola, J. Karhunen, M. Laan, A. Lissovski, P. Paris, and K. Piip held a project meeting, Tartu, Estonia, 21 February 2013.

M. Groth and T. Tala (20–22 February) participated in the JET General planning meeting 5, EFDA JET, Culham, UK, 18–22 February 2013.

T. Kiviniemi, T. Korpilo, and J. Heikkinen participated in CRESTA meeting, Åbo Academy, Turku, 21 February 2013.

M. Aints, A. Hakola, J. Karhunen, M. Kiisk, M. Laan, J. Likonen, A. Lissovski, P. Paris and K. Piip held a project meeting, Tallinn, Estonia, 4–5 March 2013.

T. Tala participated in the EFDA Steering Committee meeting, Brussels, Belgium, 11–12 March 2013.

O. Asunta and S. Äkäslompolo participated in the Integrated Tokamak Modelling Code Camp, Garching, Germany, 11–15 March 2013.

P. Alho, J.-P. Karjalainen, J. Mattila, R. Sibois, and J. Väyrynen participated in the EFDA GOT RH Winter School and workshop “Robotics, Telerobotics, and Interfaces for Remote Handling”, Paris, France, 11–22 March 2013.

A. Hakola, T. Kiviniemi, J. Miettunen, A. Sand and P. Sirén participated in the 47th Physics Days, Espoo, Finland, 14–16 March 2013.

O. Asunta participated in the 1st Chalmers Meeting on Runaway Electron Modelling (REM), Gothenburg, Sweden, 18–20 March 2013.

6. Other Activities

- A. Hakola participated in the EFDA/PPP&T Kick-off Meeting for PEX-03A, Garching, Germany, 20–21 March 2013.
- S. Leerink and A. Salmi participated in the Joint EU-US Transport Task Force Workshop, Santa Rosa, California, 8–12 April 2013.
- P. Sirén participated in Core Transport Modelling weeks in EFDA JET, Culham, UK, 8–19 April 2013.
- M. Siuko and D. Carfora participated in the EFDA WP13-DAS-07-RM Kick-off Meeting, Garching, Germany, 10 April 2013.
- T. Korpilo participated in High Level Support Team meetings, Garching, Germany, 11 April and 16 October 2013.
- R. Tuominen participated in the EFDA WP13-DTM02-RAMI Kick-off Meeting, Garching, Germany, 12 April 2013.
- M. Airila, M. Groth, A. Järvinen and A. Lasa participated in the JET Edge Modelling Meeting, EFDA JET, Culham, UK, 8–19 April 2013.
- P. Sirén participated in the JET Core Modelling Meeting, EFDA JET, Culham, UK, 8–19 April 2013.
- T. Tala participated in a CCE-FU meeting, Brussels, Belgium, 18 April 2013.
- K. Piip participated in the conference “Functional materials and Nanotechnologies-2013”, Tartu, Estonia, 22–24 April 2013.
- E. Hirvijoki, T. Kurki-Suonio and A. Snicker participated in the ITPA Energetic Particles Physics TG meeting, EFDA JET, Culham, UK, 22–24 April 2013.
- T. Tala participated in the ITPA Transport & Confinement Topical Group Meeting, Garching, Germany, 22–25 April 2013.
- E. Hirvijoki, T. Kurki-Suonio and A. Snicker participated in the meeting on 3D effects in ITER, CCFE, Culham, UK, 25–26 April 2013.
- T. Kurki-Suonio participated in the progress meeting of GRT-379 (RIPLOS-2) at CCFE, Culham, UK, 26 April 2013.
- T. Kurki-Suonio, S. Sipilä and S. Äkäslompolo participated in the 531st WE-Heraeus-Seminar “3D vs. 2D in Hot Plasmas”, Bad Honnef, Germany, 30 April–2 May 2013.
- A. Hakola K. Heinola, J. Karhunen, J. Likonen and K. Piip participated in the 14th International Conference on Plasma-Facing Materials and Components for Fusion Applications (PFMC 14), Jülich, Germany, 13–17 May 2013.
- M. Airila participated in the EFDA PIN Annual Meeting, Cadarache, France, 15–17 May 2013.

L. Aho-Mantila participated in an EFDA/PPP&T Task Planning Meeting in Garching, Germany, 17 May 2013.

48 participants in the Euratom-Tekes Annual Fusion Seminar, Silja Serenade, 27–29 May 2013. The seminar included an excursion to the Alfvén laboratory at the Royal Institute of Technology, Stockholm, Sweden. The invited speaker was Prof. Per Helander from IPP Greifswald presenting the status and future plans of W7-X.

O. Asunta participated in the ITM TF working session on NBI implementation in ETS and power control algorithms, Garching, Germany, 27–31 May 2013.

T. Tala participated in Head of the Research Unit meetings, Garching, Germany, 6–7 June and 12–13 September 2013.

R. Sibois participated in the 25th Symposium on Fusion Engineering, San Francisco, USA, 10–16 June 2013.

M. Kiisk, M. Laan, and J. Likonen participated in the 1st Semi-Annual Monitoring & General Planning Meeting of the JET Fusion Technology Task Force, EFDA JET, Culham, UK, 11–14 June 2013.

M. Siuko and J. Järvenpää participated in the Divertor PA Meeting in ITER, Cadarache, France, 25–26 June 2013.

T. Ahlgren and L. Bukonte participated in the EFDA MAT-IREMEV, MAT-HHFM and MAT-ODFS Monitoring Meeting, Bucharest, Romania, 25–28 June 2013.

T. Tala participated in F4E Governing Board meetings, Barcelona, Spain, 26–27 June and 10–11 December 2013.

M. Airila and T. Kurki-Suonio participated in the European Physical Society Plasma Physics Division Board meeting, Helsinki, Finland, 30 June 2013.

S. Leerink participated in Workshop on Impurity Transport, Chalmers University, Gothenburg, Sweden, 24–26 June 2013.

A. Hakola gave a plenary talk in the 40th EPS Conference on Plasma Physics, Espoo, Finland, 1–5 July 2013.

607 participants (incl. M. Airila, O. Asunta, M. Groth, A. Hakola, A. Järvinen, J. Karhunen, T. Kiviniemi, M. Laan, J. Miettunen, A. Salmi, S. Sipilä, P. Sirén, A. Snicker, T. Tala, S. Äkäslompolo) in the 40th EPS Conference on Plasma Physics, Espoo, Finland, 1–5 July 2013.

T. Kurki-Suonio (chair), M. Airila (scientific secretary), A. Hakola (satellite meeting), C. Björkas, E. Kilpua and S. Äkäslompolo were members of the Local Organizing Committee of the 40th EPS Conference on Plasma Physics, Espoo, Finland, 1–5 July 2013.

T. Kiviniemi and S. Sipilä played Irish music with Dr. P. McCarthy from University College Cork, Ireland, in the official Music in Fusion event of the 40th EPS Conference on Plasma Physics, Espoo, Finland, 1–5 July 2013.

6. Other Activities

45 participants in the EFDA Steering Committee meeting, Espoo, Finland, 3 July 2013. The meeting was organized by T. Tala.

A. Hakola and M. Laan participated in the EPS Satellite Conference on Plasma Diagnostics, Espoo, Finland, 6 July 2013.

36 participants (incl. O. Asunta and S. Äkäslompolo) in the Integrated Tokamak Modelling code camp, Espoo, Finland, 8–19 July 2013. T. Kiviniemi was the head of the local organizing committee.

T. Kiviniemi participated in recordings of CRESTA promotional video in London 10 July which is now published in vimeo.com/80012783

L. Aho-Mantila participated in the SOLPS optimization meeting in Garching, Germany, 29–31 July 2013.

L. Aho-Mantila participated in a detachment workshop in Garching, Germany, 1 August 2013.

J. Karhunen and P. Sirén attended the 11th Carolus Magnus Summer School on Plasma and Fusion Energy Physics, Bad Honnef, Germany, 26 August – 6 September 2013.

M. Aints, A. Hakola, M. Kiisk, M. Laan, J. Likonen, A. Lisovski, P. Paris, and K. Piip participated in the project meeting between collaborative research groups from VTT and University of Tartu within Euratom-Tekes Association, Tallinn, Estonia, 5–6 September 2013.

M. Airila participated in the 4th Integrated Tokamak Modelling Code Camp, Ljubljana, Slovenia, 9–20 September 2013.

A. Hakola and M. Laan participated in the EFDA Monitoring Meeting on WP13-A01-P1-P2-P3, Garching, Germany, 11–12 September 2013.

P. Paris participated in the EMSLIBS 2013 conference, Bari, Italy, 15–20 September 2013.

P. Alho, J. Väyrynen, R. Sibois, and J. Mattila participated in the EFDA GOT RH Workshop, Barcelona, Spain, 16 September 2013.

P. Alho, J. Mattila, T. Määttä, R. Sibois, M. Siuko, J. Tuominen, M. Viinikainen, and J. Väyrynen participated in the 11th International Symposium on Fusion Nuclear Technology, Barcelona, Spain, 16–20 September 2013.

E. Ahonen and P. Niskala participated in the IPP Summer University of Plasma Physics and Fusion Research, Greifswald, Germany, 16–20 September 2013.

T. Korpilo participated in the 14th International Workshop on Plasma Edge Theory in Fusion Devices, Cracow, Poland, 23–25 September 2013.

J. Järvenpää and D. Carfora participated in the EFDA WP13-DAS-07-RM Iterim Review Meeting, Garching, Germany, 26 September 2013.

T. Tala participated in the EFDA Steering Committee meeting, Frascati, Italy, 7–8 October 2013.

S. Leerink gave an invited talk in the ESF Exploratory Workshop on Multi-Scale Methods for Wave and Transport Processes in Fusion Plasmas: The Legacy of Grigory Pereverzev, Garching, Germany, 13–16 October 2013.

A. Hakola participated in the 1st MST General Planning Meeting and ASDEX Upgrade Programme Seminar, Beilngries, Germany, 20–25 October 2013.

L. Aho-Mantila, M. Airila, A. Hakola, M. Laan, and M. Siuko participated in an information meeting supporting the EUROFUSION Consortium Call for Participation in IPH and PPP&T Work Packages, Garching, Germany, 27–30 October 2013.

A. Salmi participated in the 8th Fusion Data Validation Workshop, Gent, Belgium, 4–6 November 2013.

L. Aho-Mantila participated in the E2M seminar in Ringberg, Germany, 5–6 November 2013.

L. Aho-Mantila participated in the 55th Annual Meeting of the APS Division of Plasma Physics, Denver, Colorado, 11–15 November 2013.

T. Tala participated in a Head of the Research Unit meeting, Brussels, Belgium, 20–21 November 2013.

A. Hakola, M. Laan, A. Lasa, and J. Likonen participated in the 12th Annual Meeting of the EFDA PWI Task Force, Lisbon, Portugal, 26–29 November 2013.

P. Niskala and M. Santala participated in the Finnish-Russian seminar on high temperature plasma physics, St. Petersburg, Russia, 4–6 December 2013.

T. Kurki-Suonio participated in the European Physical Society Plasma Physics Division Board meeting, Paris, France, 6 December 2013.

A. Hakola participated in the 21st European Fusion Physics Workshop, Ringsted, Denmark, 9–11 December 2013.

T. Tala participated in a Head of the Research Unit meeting, Barcelona, Spain, 12 December 2013.

T. Ahonen participated in the EFDA WP13-DTM02-RAMI Final Meeting, Garching, Germany, 13 December 2013.

M. Siuko and D. Carfora participated in the EFDA WP13-DAS-07-RM Final Meeting, Garching, Germany, 16–17 December 2013.

6.2 Visits

L. Aho-Mantila worked as a visiting researcher at Max-Planck-Institut für Plasma-physik, Garching, Germany, 1 January – 31 December 2013.

6. Other Activities

J. Lönnroth was seconded to EFDA JET, Culham, UK, 1 January – 31 December 2013.

A. Hakola visited Max-Planck-Institut für Plasmaphysik, Garching, Germany, 6–18 January and 9–20 September 2013.

A. Järvinen visited Forschungszentrum Jülich, Jülich, Germany, 14–25 January 2013.

A. Lissovski visited VTT Technical Research Centre of Finland, Espoo, Finland, 27 January – 1 February, 5–10 May, and 28 October – 1 November 2013.

A. Lasa and J. Likonen visited Institute of Atomic Physics, Bucharest, Romania, 11–13 February 2013.

A. Hakola and J. Karhunen visited University of Tartu, Tartu, Estonia, 20–21 February 2013.

O. Asunta visited CCFE, Culham, UK, 25 February – 8 March and 13–24 May 2013.

A. Sand visited CCFE, Culham, UK, 25 February – 2 March 2013.

S. Äkäslompolo visited Max-Planck-Institut für Plasmaphysik, Garching, Germany, 15–20 March 2013.

M. Groth visited General Atomics, San Diego, USA, 30 April–5 May 2013.

A. Hakola, M. Laan, P. Paris, and K. Piip visited FOM institute DIFFER, Nieuwegein, the Netherlands, 6 May 2013.

T. Kurki-Suonio visited the School of Electrical Engineering, KTH, Stockholm, Sweden, and acted as the opponent of Qaisar Mukhtar's PhD thesis "On Monte Carlo Operators for Studying Collisional Relaxation in Toroidal Plasmas", 13 May 2013.

A. Salmi visited CRPP, École Polytechnique Fédérale, Lausanne, Switzerland, 19 June 2013.

K. Piip visited FOM Institute DIFFER, Nieuwegein, the Netherlands, 16–28 June and 22–31 August 2013.

A. Lissovski visited FOM Institute DIFFER, Nieuwegein, the Netherlands, 16–21 and 22–31 August 2013.

J. Karhunen visited FOM Institute DIFFER, Nieuwegein, the Netherlands, 24–28 June 2013.

R. Sibois visited FOM Institute DIFFER, Nieuwegein, the Netherlands, 24 June – 19 July 2013.

L. Aho-Mantila was seconded to EFDA JET, Culham, UK, 12–23 August and 2–27 September 2013.

P. Sirén was seconded to EFDA JET, Culham, UK, 19–23 August 16–20 September, and 21 October – 8 November 2013.

T. Tala was seconded to EFDA JET, Culham, UK, 19–23 August, 11–20 September, and 28 October – 1 November 2013.

S. Leerink and T. Kiviniemi (19–21 March) visited Forschungszentrum Jülich, Jülich, Germany, 19–23 August 2013.

P. Alho and J. Väyrynen were seconded to EFDA JET, Culham, UK, 2 September – 25 October 2013.

A. Järvinen was seconded to EFDA JET, Culham, UK, 2–13 September and 14 October – 12 November 2013.

M. Groth was seconded to EFDA JET, Culham, UK, 2–13 September and 18–25 October 2013.

A. Salmi was seconded to EFDA JET, Culham, UK, 9–20 September and 28 October – 1 November 2013.

R. Sibois was seconded to EFDA JET, Culham, UK, 14 October–8 November 2013.

M. Kiisk visited Institute of Chemical Physics, University of Latvia, Riga, Latvia, 14–16 October 2013.

A. Snicker visited Max-Planck-Institut für Plasmaphysik, Garching, Germany, 20–25 October 2013.

J.P. Coad, K. Heinola, and J. Likonen visited IST/IPFN, Lisbon, Portugal, 18–20 November 2013.

6.3 Visitors

Delegation of Oman (Abdullah Al-Sarmi, Undersecretary of the Minister of Higher Education, Dr. Al-Rabie Said Hamed Said, Advisor to the Minister of Higher Education, Mrs. Aziza Bent Hamad Al-Haritia, MoHE, His Excellency Office, Dr. Abdullah Al-Shibli, Director of DG-CAS, Dr. Anasse Bouhlal, Program Director of Engineering, DG-CAS, Dr. Ali Hassan Khamis Al-Lawati, Dean, Sohar College of Applied Sciences) visited VTT Technical Research Centre of Finland (DTP2), 27 February 2013.

F. Jaulmes and E. Westerhof, FOM Institute DIFFER, Nieuwegein, the Netherlands, visited Aalto University, 15–19 April 2013.

A group of members of the Finnish Nuclear Society visited VTT Technical Research Centre of Finland (DTP2), 19 April 2013.

H. Plit and J. Aurela, Ministry of Employment and the Economy, visited Technical Research Centre of Finland (DTP2), 14 May 2013.

6. Other Activities

A.G. Fernandez, Universidad de Almeria, Spain, and J. Virtanen, University of Oulu, visited Tampere University of Technology, 14 June 2013 and acted as the opponents in the doctoral defence of Jean-Baptiste Izard.

L. Jones, ITER, Cadarache, France, visited VTT Technical Research Centre of Finland, 17–18 June 2013.

H. Bindslev, F4E, Barcelona, Spain, visited Technical Research Centre of Finland (DTP2), 5 July 2013.

P. Viitanen, Ministry of Transport and Communication in Finnish parliament, visited VTT Technical Research Centre of Finland (DTP2), 10 July 2013.

Economy Committee of Finnish Parliament and Council of Tampere region (Mauri Pekkarinen, Marjo Matikainen-Kallström, Lars Erik Gästgivars, Teuvo Hakkarainen, Harri Jaskari, Antti Kaikkonen, Johanna Karimäki, Pia Kauma, Miapetra Kumpula-Natri, Päivi Lipponen, Jari Myllykoski, Martti Mölsä, Sirpa Paatero, Kaj Turunen, Tuula Kulovesi, Teija Miller, Hanna Tainio, Sofia Vikman, Arto Pirttilahti, Anna Kontula, Oras Tynkkynen and Leena Rauhala) visited VTT Technical Research Centre of Finland (DTP2), 15 August 2013.

O. Kalha, ITER, Cadarache, France, visited VTT Technical Research Centre of Finland (DTP2), 19 August 2013.

M. Irzak, A. Gurchenko, and E. Gusakov, Ioffe Institute, St. Petersburg, Russia visited Aalto University, 15–19 December 2013.

Publications 2013

6.4 Fusion Physics and Plasma Engineering

6.4.1 Publications in scientific journals

1. T. Makkonen, M. Groth, M. Airila, A. Janzer, T. Kurki-Suonio, T. Lunt, H.W. Mueller, T. Puetterich, E. Viezzer and the ASDEX Upgrade team, Synthetic Doppler spectroscopy and curvilinear camera diagnostics in the ERO code, *Computer Physics Communications* **184** (2013) 1842–1847.
2. I.T. Chapman, J.P. Graves, O. Sauter, C. Zucca, O. Asunta, R.J. Buttery, S. Coda, T. Goodman, V. Igochine, T. Johnson, M. Jucker, R.J. La Haye, M. Lennholm and JET-EFDA Contributors, Power requirements for electron cyclotron current drive and ion cyclotron resonance heating for sawtooth control in ITER, *Nuclear Fusion* **53** (2013) 066001.
3. X. Litaudon, I. Voitsekhovitch, J.F. Artaud, P. Belo, João P.S. Bizarro, T. Casper, J. Citrin, E. Fable, J. Ferreira, J. Garcia, L. Garzotti, G. Giruzzi, J. Hobirk, G.M.D. Hogeweij, F. Imbeaux, E. Joffrin, F. Koechl, F. Liu, J. Lönnroth, D. Moreau, V. Parail, M. Schneider, P.B. Snyder, the ASDEX-Upgrade Team, JET-EFDA Contributors¹⁰ and the EU-ITM ITER Scenario Modelling Group, Modelling of hybrid scenario: from present-day experiments towards ITER, *Nuclear Fusion* **53** (2013) 073024.
4. J.W. Coenen, M. Sertoli, S. Brezinsek, I. Coffey, R. Dux, C. Giroud, M. Groth, D. Ivanova, K. Krieger, K.D. Lawson, S. Marsen, A.G. Meigs, R. Neu, T. Puetterich, G.J. van Rooij, M.F. Stamp and JET-EFDA contributors, Long-term evolution of the impurity composition and impurity events with the ITER-like wall at JET, *Nuclear Fusion* **53** (2013) 073043.
5. S. Brezinsek, T. Loarer, V. Philipps, H.G. Esser, S. Grünhagen, R. Smith, R. Felton, J. Banks, P. Belo, A. Boboc, J. Bucalossi, M. Clever, J.W. Coenen, I. Coffey, S. Devaux, D. Douai, M. Freisinger, D. Frigione, M. Groth, A. Huber, J. Hobirk, S. Jachmich, S. Knipe, K. Krieger, U. Kruezi, S. Marsen, G.F. Matthews, A.G. Meigs, F. Nave, I. Nunes, R. Neu, J. Roth, M.F. Stamp, S. Vartanian, U. Samm and JET EFDA contributors, Fuel retention studies with the ITER-Like Wall in JET, *Nuclear Fusion* **53** (2013) 083023.
6. M. Groth, S. Brezinsek, P. Belo, M.N.A. Beurskens, M. Brix, M. Clever, J.W. Coenen, C. Corrigan, T. Eich, J. Flanagan, C. Guillemaut, C. Giroud, D. Harting, A. Huber, S. Jachmich, U. Kruezi, K.D. Lawson, M. Lehnen, C. Lowry, C.F. Maggi, S. Marsen, A.G. Meigs, R.A. Pitts, G. Sergienko, B. Sieglin, C. Silva, A. Sirinelli, M.F.

- Stamp, G.J. van Rooij, S. Wiesen and the JET-EFDA Contributors, Impact of carbon and tungsten as divertor materials on the scrape-off layer conditions in JET, *Nuclear Fusion* **53** (2013) 093016.
7. M. Willensdorfer, E. Fable, E. Wolfrum, L. Aho-Mantila, F. Aumayr, R. Fischer, F. Reimold, F. Ryter and the ASDEX Upgrade Team, Particle transport analysis of the density build-up after the L–H transition in ASDEX Upgrade, *Nuclear Fusion* **53** (2013) 093020.
 8. A. Snicker, E. Hirvijoki and T. Kurki-Suonio, Power loads to ITER first wall structures due to fusion alphas in non-axisymmetric magnetic field including the presence of MHD modes, *Nuclear Fusion* **53** (2013) 093028.
 9. U. Stroth et al. (incl. L. Aho-Mantila, S. Äkäslompolo, A. Hakola, T. Kurki-Suonio, T. Makkonen and T. Tala), Overview of ASDEX Upgrade results, *Nuclear Fusion* **53** (2013) 104003.
 10. H. Meyer et al. (incl. O. Asunta), Overview of physics results from MAST towards ITER/DEMO and the MAST Upgrade, *Nuclear Fusion* **53** (2013) 104008.
 11. M. Garcia-Munoz, S. Äkäslompolo, O. Asunta, J. Boom, X. Chen, I.G.J. Classen, R. Dux, T.E. Evans, S. Fietz, R.K. Fisher, C. Fuchs, B. Geiger, M. Hoelzl, V. Igochine, Y.M. Jeon, J. Kim, J.Y. Kim, B. Kurzan, N. Lazanyi, T. Lunt, R.M. McDermott, M. Nocente, D.C. Pace, T.L. Rhodes, M. Rodriguez-Ramos, K. Shinohara, W. Suttrop, M.A. Van Zeeland, E. Viezzer, M. Willensdorfer, E. Wolfrum, the ASDEX Upgrade, DIII-D and KSTAR Teams, Fast-ion redistribution and loss due to edge perturbations in the ASDEX Upgrade, DIII-D and KSTAR tokamaks, *Nuclear Fusion* **53** (2013) 123008.
 12. G. Kramer, A. McLean, N. Brooks, R. Budny, X. Chen, W. Heidbrink, T. Kurki-Suonio, R. Nazikian, T. Koskela, M. Schaffer, K. Shinohara, J. Snipes and M. Van Zeeland, Simulation of localized fast-ion heat loads in test blanket module simulation experiments on DIII-D, *Nuclear Fusion* **53** (2013) 123018.
 13. C. Silva, G. Arnoux, M. Groth, C. Hidalgo, S. Marsen and JET-EFDA Contributors, Observation of geodesic acoustic modes in the JET edge plasma, *Plasma Physics and Controlled Fusion* **55** (2013) 025001.
 14. B. Baiocchi, P. Mantica, C. Giroud, T. Johnson, V. Naulin, A. Salmi, T. Tala, M. Tsalas and JET-EFDA contributors, Experimental investigation of the role of rotation and rotation gradient on ITG stiffness by varying the rotation profile at constant power using enhanced magnetic field ripple or EFCC at JET, *Plasma Physics and Controlled Fusion* **55** (2013) 025010.
 15. A. Hakola, M.I. Airila, C. Björkas, D. Borodin, S. Brezinsek, J.P.Coad, M. Groth, A. Järvinen, A. Kirschner, S. Koivuranta, K. Krieger, T. Kurki-Suonio, J. Likonen, V. Lindholm, T. Makkonen, M. Mayer, J. Miettunen, H.W. Müller, R. Neu, P. Petersson, V. Rohde, M. Rubel, A. Widdowson, the ASDEX Upgrade Team and JET-EFDA Contributors, Global migration of impurities in tokamaks, *Plasma Physics and Controlled Fusion* **55** (2013) 124029.
 16. E.Z. Gusakov, A.B. Altukhov, V.V. Bulanin, A.D. Gurchenko, J.A. Heikkinen, S.J. Janhunen, S. Leerink, L.A. Esipov, M.Yu. Kantor, T.P. Kiviniemi, T. Korpilo, D.V. Kouprienko, S.I. Lashkul, A.V. Petrov, and N.V. Teplova, Anomalous transport and multi-scale drift turbulence dynamics in tokamak ohmic discharge as measured by high resolution diagnostics and modeled by full-f gyrokinetic code, *Plasma Physics and Controlled Fusion* **55** (2013) 124034.

17. E. Hirvijoki, A. Brizard, A. Snicker and T. Kurki-Suonio, Monte Carlo implementation of a guiding-center Fokker-Planck kinetic equation, *Physics of Plasmas* **20** (2013) 092505.
18. T. Korpilo, J.A. Heikkinen, S.J. Janhunen, T.P. Kiviniemi, S. Leerink, and F. Ogando, Numerically stable method for kinetic electrons in gyrokinetic particle-in-cell simulations of toroidal plasmas, *Journal of Computational Physics* **239** (2013) 22.
19. A. Lasa, K.O.E. Henriksson, and K. Nordlund, MD simulations of onset of tungsten fuzz formation under helium irradiation, *Nuclear Instruments and Methods in Physics Research B* **303** (2013) 156.
20. A. Meinander, C. Björkas, and K. Nordlund, The effect of hydrocarbon chemistry on sputtering in mixed Be-C-H materials, *Nuclear Instruments and Methods in Physics Research B* **303** (2013) 188.
21. G.J. van Rooij, J.W. Coenen, L. Aho-Mantila, S. Brezinsek, M. Clever, R. Dux, M. Groth, K. Krieger, S. Marsen, G.F. Matthews, A. Meigs, R. Neu, S. Potzel, T. Pütterich, J. Rapp, M.F. Stamp, the ASDEX Upgrade Team, JET-EFDA Contributors, Tungsten divertor erosion in all metal devices: Lessons from the ITER like wall of JET, *Journal of Nuclear Materials* **438** (2013) S42–S47.
22. B. Pégourié, S. Panayotis, P. Languille, C. Martin, T. Dittmar, E. Gauthier, J.-C. Hatchressian, J.-Y. Pascal, P. Roubin, R. Ruffe, E. Tsitrone, S. Vartanian, H. Wang, A. Beauté, J. Bouvet, C. Brosset, J. Bucalossi, M. Cabié, E. Caprin, X. Courtois, R. Dachicourt, E. Delchambre, C. Dominici, D. Douai, A. Ekedahl, J.P. Gunn, A. Hakola, W. Jacob, H. Khodja, J. Likonen, F. Linez, A. Litnovsky, Y. Marandet, S. Markelj, A. Martinez, M. Mayer, O. Meyer, P. Monier-Garbet, P. Moreau, V. Negrier, P. Odon, C. Pardanaud, B. Pasquet, P. Pelicon, P. Petersson, V. Philipps, G. Possnert, D. Reiter, J. Roth, I. Roure, M. Rubel, F. Saint-Laurent, F. Samaille and P. Vavpetic, Deuterium inventory in Tore Supra: Coupled carbon–deuterium balance, *Journal of Nuclear Materials* **438** (2013) S120–S125.
23. A. Huber, S. Brezinsek, M. Groth, P.C. de Vries, V. Riccardo, G. van Rooij, G. Sergienko, G. Arnoux, A. Boboc, P. Bilkova, G. Calabro, M. Clever, J.W. Coenen, M.N.A. Beurkens, T. Eich, S. Jachmich, M. Lehnen, E. Lerche, S. Marsen, G.F. Matthews and the EFDA-JET contributors, Impact of the ITER-like wall on divertor detachment and on the density limit in the JET tokamak, *Journal of Nuclear Materials* **438** (2013) S139.
24. M. Groth, S. Brezinsek, P. Belo, G. Corrigan, D. Harting, S. Wiesen, M.N.A. Beurskens, M. Brix, M. Clever, J.W. Coenen, T. Eich, J. Flanagan, C. Giroud, A. Huber, S. Jachmich, U. Kruezi, M. Lehnen, C. Lowry, C.F. Maggi, S. Marsen, A.G. Meigs, G. Sergienko, B. Sieglin, C. Silva, A. Sirinelli, M.F. Stamp, G.J. van Rooij and the EFDA-JET contributors, Target particle and heat loads in low-triangularity L-mode plasmas in JET with carbon and beryllium/tungsten walls, *Journal of Nuclear Materials* **438** (2013) S175.
25. C. Silva, G. Arnoux, S. Devaux, D. Frigione, M. Groth, J. Horacek, P.J. Lomas, S. Marsen, G.F. Matthews, R.A. Pitts and the EFDA-JET contributors, Comparison of scrape-off layer transport in inner and outer wall-limited JET plasmas, *Journal of Nuclear Materials* **438** (2013) S189.
26. D. Borodin, M. Stamp, A. Kirschner, C. Björkas, S. Brezinsek, J. Miettunen, D. Matveev, C. Silva, O. Van Hoey, M. Groth, S. Marsen, V. Philipps and JET-EFDA contributors, Spectroscopic Measurements of Be Erosion at JET ILW and interpretation with ERO modelling, *Journal of Nuclear Materials* **438** (2013) S267–S271.
27. S. Brezinsek, S. Jachmich, M.F. Stamp, A.G. Meigs, J.W. Coenen, K. Krieger, C. Giroud, M. Groth, V. Philipps, S. Grünhagen, R. Smith, G.J. van Rooij, D. Ivanova,

- G.F. Matthews and the EFDA-JET contributors, Residual carbon content in the initial ITER-Like Wall experiments at JET, *Journal of Nuclear Materials* **438** (2013) S303.
28. L. Aho-Mantila, X. Bonnin, S. Brezinsek, C. Lowry, S. Marsen, H.W. Müller, S. Potzel, S. Wiesen, M. Wischmeier, the ASDEX Upgrade Team and JET-EFDA Contributors, L-mode radiative plasma edge studies for model validation in ASDEX Upgrade and JET, *Journal of Nuclear Materials* **438** (2013) S321–S325.
29. S. Marsen, T. Eich, M. Groth, S. Jachmich, B. Sieglin and the EFDA-JET contributors, Experimental sheath heat transmission factors in diverted plasmas in JET, *Journal of Nuclear Materials* **438** (2013) S393.
30. T. Makkonen, M. Groth, M.I. Airila, A. Janzer, T. Kurki-Suonio, T. Lunt, H.W. Müller, T. Pütterich, E. Viezzer and the ASDEX Upgrade team, Measurements and ERO simulations of carbon flows in the high-field side main SOL in AUG, *Journal of Nuclear Materials* **438** (2013) S410–S413.
31. D. Harting, M. Groth, M. Beurskens, P. Boerner, M. Brix, J.W. Coenen, G. Corrigan, M. Lehnen, S. Marsen, G.J. van Rooij, D. Reiter, S. Wiesen and the EFDA-JET contributors, Simulation of tungsten sputtering with EDGE2D-EIRENE in low-triangularity L-mode JET ITER-like wall configuration, *Journal of Nuclear Materials* **438** (2013) S480.
32. D. Tskhakaya, M. Groth and the EFDA-JET contributors, 1D kinetic modelling of the JET SOL with tungsten divertor, *Journal of Nuclear Materials* **438** (2013) S522.
33. M.I. Airila, C. Björkas, A. Lasa, A. Meinander, K. Nordlund and K. Vörtler, Sputtering of Be/C/W compounds in Molecular Dynamics and ERO simulations, *Journal of Nuclear Materials* **438** (2013) S589–S593.
34. J. Miettunen, M. Groth, T. Kurki-Suonio, H. Bergsäter, J. Likonen, S. Marsen, C. Silva, S. Äkäslompolo and JET EFDA contributors, Predictive ASCOT modelling of ¹⁰Be transport in JET with the ITER-like wall, *Journal of Nuclear Materials* **438** (2013) S612–S615.
35. P. Petersson, A. Hakola, J. Likonen, M. Mayer, J. Miettunen, R. Neu, V. Rohde, M. Rubel, the ASDEX-Upgrade Team, Injection of nitrogen-15 tracer into ASDEX-Upgrade: New technique in material migration studies, *Journal of Nuclear Materials* **438** (2013) S616–S619.
36. C. Guillemaut, R.A. Pitts, J. Bucalossi, G. Corrigan, A.S. Kukushkin, D. Harting, A. Huber, M. Wischmeier, G. Arnoux, S. Brezinsek, S. Devaux, J. Flanagan, M. Groth, S. Jachmich, U. Kruezi, S. Marsen, J. Strachan, S. Wiesen and the EFDA-JET contributors, EDGE2D-EIRENE modelling of divertor detachment in JET high-triangularity L-mode plasmas in carbon and Be/W environment, *Journal of Nuclear Materials* **438** (2013) S638.
37. A. Hakola, S. Koivuranta, J. Likonen, M. Groth, T. Kurki-Suonio, V. Lindholm, T. Makkonen, J. Miettunen, K. Krieger, M. Mayer, H.W. Mueller, R.L. Neu, V. Rohde, P. Petersson, ASDEX Upgrade Team, Global migration of ¹³C in high-density L-mode plasmas at ASDEX Upgrade, *Journal of Nuclear Materials* **438** (2013) S694–S697.
38. P. Paris, A. Hakola, K. Bystrov, G. De Temmerman, M. Aints, M. Kiisk, J. Kozlova, M. Laan, J. Likonen, and A. Lissovski, Erosion of marker coatings exposed to Pilot-PSI plasma, *Journal of Nuclear Materials* **438** (2013) S754–S757.
39. J. Likonen, A. Hakola, S. Koivuranta, E. Ahonen, M.I. Airila, E. Alves, N. Barradas, J.P. Coad, A. Widdowson, M. Rubel, S. Brezinsek, and JET- EFDA Contributors, Local deposition of ¹³C tracer in the JET MKII-HD divertor, *Journal of Nuclear Materials* **438** (2013) S762–S765.

40. K. Heinola and T. Ahlgren Hydrogen retention to impurities in tungsten: A multi-scale study, *Journal of Nuclear Materials* **438** (2013) S1001–S1004.
41. A. Järvinen, M. Groth, D. Moulton, J. Strachan, S. Wiesen, P. Belo, M. Beurskens, G. Corrigan, T. Eich, C. Giroud, E. Havlickova, S. Jachmich, M. Lehnen, J. Lönnroth, D. Tskhakaya, and JET EFDA contributors, Simulations of Tungsten Transport in the Edge of JET ELMy H-mode Plasmas, *Journal of Nuclear Materials* **438**, (2013) S1005–S1009.
42. C. Björkas and K. Nordlund, Variables affecting simulated Be sputtering yields, *Journal of Nuclear Materials* **439** (2013) 174.
43. R. Coelho, S. Äkäslompolo, A. Dinklage, A. Kus, R. Reimer, E. Sundén, S. Conroy, E. Blanco, G. Conway, S. Hacquin, S. Heurax, C. Lechte, F. Da Silva, A. Sirinelli, ITM-TF Contributors, Synthetic Diagnostics in the European Union Integrated Tokamak Modelling Simulation Platform, *Fusion Science and Technology* **63** (2013) 1–8.
44. A. Kirschner, D. Matveev, M. Groth, S. Brezinsek, V. Kotov, K. Krieger, D. Borodin, C. Björkas, M. Airila, H.G. Esser, G. Sergienko, U. Samm and JET EFDA Contributors, Modeling of Impurity Transport in the Divertor of JET, *Plasma and Fusion Research* **8** (2013) 2402038.
45. M. Wisse, L. Marot, A. Widdowson, M. Rubel, D. Ivanova, P. Petersson, R.P. Doerner, M.J. Baldwin, J. Likonen, E. Alves, A. Hakola, S. Koivuranta, R. Steiner, E. Meyer and EFDA-JET Contributors, Laser cleaning of beryllium-containing first mirror samples from JET and PISCES-B, *Fusion Engineering and Design*, accepted.
46. D. Borodin, S. Brezinsek, J. Miettunen, M. Stamp, A. Kirschner, C. Björkas, M. Groth, S. Marsen, S. Lisgo, D. Matveev, M. Airila, V. Philipps and JET EFDA Contributors, Determination of Be sputtering yields from spectroscopic observations at the JET ILW based on 3D ERO modelling, *Physica Scripta*, accepted.
47. A. Hakola, J. Karhunen, S. Koivuranta, J. Likonen, M. Balden, A. Herrmann, M. Mayer, H.W. Müller, R. Neu, V. Rohde, K. Sugiyama, and the ASDEX Upgrade team, Long-term erosion of plasma-facing materials with different surface roughness in ASDEX Upgrade, *Physica Scripta*, accepted.
48. A. Lasa, K. Schmid and K. Nordlund, Modelling of W-Be mixed material sputtering under D irradiation, *Physica Scripta*, accepted.
49. P. Petersson, M. Rubel, G. Possnert, S. Brezinsek, A. Kreter, S. Möller, A. Hakola, M. Mayer, J. Miettunen, M.I. Airila, T. Makkonen, R. Neu, V. Rohde, TEXTOR Team and ASDEX Upgrade Team, Overview of Nitrogen-15 application as a tracer gas for material migration and retention studies in tokamaks, *Physica Scripta*, accepted.
50. K. Piip, P. Paris, A. Hakola, K. Bystrov, G. De Temmerman, M. Aints, I. Jögi, J. Kozlova, M. Laan, J. Likonen, A. Lissovski, H. Mändar, Influence of He/D2 plasma fluxes on tungsten coatings morphology and crystallinity, *Physica Scripta*, accepted.
51. R.J. Buttery, S. Gerhardt, A. Isayama, R.J. La Haye, E.J. Strait, D. Chandra, S. Coda, J. De Grassie, P. Gohil, M. Gryaznevich, C. Holcomb, D.F. Howell, G. Jackson, M. Maraschek, A. Polevoi, H. Reimerdes, D. Raju, A. Sen, T. Tala, JET-EFDA contributor, Cross-Machine Scaling of Neoclassical Tearing Modes Thresholds with Rotation, *Nuclear Fusion*, submitted.
52. T.P. Kiviniemi, S. Leerink, P. Niskala, J.A. Heikkinen, T. Korpilo, and S. Janhunen, Comparison of gyrokinetic simulation of parallel plasma conductivity to analytical models, *Plasma Physics and Controlled Fusion*, submitted.

6.4.2 Conference articles – physics and plasma engineering

53. F. Reimold, L. Aho-Mantila, M. Bernert, D. Coster, A. Kallenbach, A. Scarabosio, S. Potzel, M. Wischmeier and the ASDEX Upgrade Team, H-Mode Detachment in full-tungsten ASDEX Upgrade, DPG-Frühjahrstagung, Jena, Germany, February 25–March 1, 2013.
54. O. Asunta, S. Äkäslompolo, E. Hirvijoki, T. Koskela, T. Kurki-Suonio, S. Sipilä, A. Snicker, M. García-Muñoz, and the ASDEX Upgrade Team, ASCOT: Modelling Fast Ions in 3D Magnetic Fields, 1st Chalmers Meeting on Runaway Electron Modelling (REM), Gothenburg, Sweden, 18–22 March 2013.
55. A. Hakola, ASDEX Upgrade Team, JET-EFDA Contributors, contributors from the Euratom Associations CCFE, FZJ, IPP-Garching, Tekes-VTT, Tekes-Aalto, and VR, Migration of impurities in fusion reactors: what have we learnt?, 40th European Physical Society Conference on Plasma Physics, Espoo, Finland, July 1–5, 2013, Plenary talk I1.101.
56. G. Maddison, C. Giroud, M. Beurskens, S. Brezinsek, P. Devynck, T. Eich, L. Garzotti, S. Jachmich, A. Järvinen, C. Lowry, S. Marsen, K. McCormick, A. Meigs, F. Rimini, M. Stamp, M. Wischmeier and JET EFDA contributors, Contrasting H-mode behaviour with fuelling and nitrogen seeding in the all-carbon and metallic versions of JET, 40th European Physical Society Conference on Plasma Physics, Espoo, Finland, July 1–5, 2013, Paper O2.116.
57. K.D. Lawson, M. Groth, C.F. Maggi, R. Barnsley, P. Belo, S. Brezinsek, G. Corrigan, D. Harting, M. Lehnen, S. Marsen, A.G. Meigs, M.F. Stamp, S. Tyrrell and JET-EFDA Contributors, Comparisons between EDGE2D/EIRENE simulations and D and low Z impurity spectral emission from JET ITER-like wall L-mode plasmas, 40th European Physical Society Conference on Plasma Physics, Espoo, Finland, July 1–5, 2013, Paper P1.101.
58. J.A. Heikkinen, T. Korpilo, T. Pyy, S.J. Janhunen, T.P. Kiviniemi and S. Leerink, Gyrokinetic calculation of plasma transport with a material boundary, 40th European Physical Society Conference on Plasma Physics, Espoo, Finland, July 1–5, 2013, Paper P1.109.
59. P. Belo, J. Strachan, M. Groth, G. Corrigan, D. Harting, S. Brezinsek and JET EFDA contributors, EDGE2D/EIRENE simulations of the W event after X-point formation with the new JET-ILW, 40th European Physical Society Conference on Plasma Physics, Espoo, Finland, July 1–5, 2013, Paper P1.112.
60. B. Viola, D. Frigione, P. Belo, M. Groth, M. Kempenaars, U. Kruezi, S. Marsen, M. Stamp and JET EFDA Contributors, Study of the effect of the outer-strike point location on the divertor neutral pressure in JET-ILW using EDGE2D/EIRENE, 40th European Physical Society Conference on Plasma Physics, Espoo, Finland, July 1–5, 2013, Paper P1.114.
61. M. Groth, P. Belo, S. Brezinsek, M. Brix, J.W. Coenen, C. Corrigan, J. Flanagan, D. Harting, A. Huber, S. Jachmich, A. Järvinen, U. Kruezi, M. Lehnen, C. Lowry, A.G. Meigs, S. Marsen, S. Munaretto, M.F. Stamp and JET EFDA Contributors, Divertor plasma and neutral conditions in JET-ILW ohmic plasmas in semi-horizontal and vertical divertor configurations, 40th European Physical Society Conference on Plasma Physics, Espoo, Finland, July 1–5, 2013, Paper P1.115.
62. T. Koskela, O. Asunta, P. Belo, M. O'Mullane, M. Romanelli, S. Sipilä and JET-EFDA contributors, Modelling of the effect of the ITER-like wall on NBI heating in JET, 40th

- European Physical Society Conference on Plasma Physics, Espoo, Finland, July 1–5, 2013, Paper P1.136.
63. A. Snicker, E. Hirvijoki and T. Kurki-Suonio, The effect of NTMs and TAEs on fast particles in ITER, 40th European Physical Society Conference on Plasma Physics, Espoo, Finland, July 1–5, 2013, P1.163.
 64. A.B. Altukhov, L.A. Esipov, A.D. Gurchenko, E.Z. Gusakov, M.A. Irzak, M.Yu. Kantor, D.V. Kouprienko, S.I. Lashkul, S. Leerink and N.V. Teplova, Turbulence wave number spectra in the FT-2 tokamak by radial correlation Doppler reflectometry, 40th European Physical Society Conference on Plasma Physics, Espoo, Finland, July 1–5, 2013, Paper P1.170.
 65. J. Miettunen, M.I. Airila, T. Makkonen, M. Groth, A. Hakola, V. Lindholm, H.W. Müller and the ASDEX Upgrade Team, Dissociation of $^{13}\text{CH}_4$ and $^{15}\text{N}_2$ and the global transport of impurities in an ASDEX Upgrade L-mode plasma, 40th European Physical Society Conference on Plasma Physics, Espoo, Finland, July 1–5, 2013, Paper P2.125.
 66. M.I. Airila, A. Järvinen, M. Groth, S. Brezinsek, J.P. Coad, S. Jachmich, A. Kirschner, J. Likonen, A. Meigs, M. Rubel, A. Widdowson and JET-EFDA Contributors, Redeposition dynamics of trace ^{13}C in H-mode divertor conditions, 40th European Physical Society Conference on Plasma Physics, Espoo, Finland, July 1–5, 2013, Paper P2.126.
 67. A. Järvinen, M. Groth, P. Belo, S. Brezinsek, G. Corrigan, T. Eich, D. Harting, C. Giroud, S. Jachmich, G. Maddison, S. Marsen, A.G. Meigs, D. Moulton, G. Sergienko, S. Wiesen and JET-EFDA contributors, Impact of the carbon and tungsten wall materials on deuterium recycling and neutral fuelling in JET using EDGE2D/EIRENE, 40th European Physical Society Conference on Plasma Physics, Espoo, Finland, July 1–5, 2013, 40th European Physical Society Conference on Plasma Physics, Espoo, Finland, July 1–5, 2013, Paper P2.130.
 68. H. Weisen, Y. Camenen, A. Salmi, M. Gelfusa and JET-EFDA contributors, Residual stress and pinch contributions to momentum transport in JET neutral beam heated H-modes, 40th European Physical Society Conference on Plasma Physics, Espoo, Finland, July 1–5, 2013, Paper P2.131.
 69. E. Militello Asp, V. Parail, L. Garzotti, P. da Silva Aresta Belo, G. Corrigan, C. Giroud, D. Harting, F. Koechl, T. Koskela, G. Maddison, M. Romanelli and the JET EFDA Contributors, Status of Integrated Modelling of JET-ILW Plasmas with N2 seeding, 40th European Physical Society Conference on Plasma Physics, Espoo, Finland, July 1–5, 2013, Paper P2.158.
 70. P. Sirén, T. Tala, G. Corrigan, J. Garcia, X. Litaudon, A. Salmi and JET EFDA contributors, Current profile modelling in JET and JT-60U identity plasma experiments, 40th European Physical Society Conference on Plasma Physics, Espoo, Finland, July 1–5, 2013, Paper P2.162.
 71. V. Rozhansky, E. Kaveeva, I. Veselova, S. Voskoboynikov, D. Coster, L. Aho-Mantila, L. Barrera, G.D. Conway, R. Fischer, A. Scarabosio, E. Wolfrum and the ASDEX Upgrade team, Modeling of I-phase of ASDEX-Upgrade, 40th European Physical Society Conference on Plasma Physics, Espoo, Finland, July 1–5, 2013, Paper P2.170.
 72. T.P. Kiviniemi, P. Niskala, S. Leerink, J. Heikkinen, S. Janhunen and T. Korpilo, Gyrokinetic simulation of GAMs in Textor plasma edge, 40th European Physical Society Conference on Plasma Physics, Espoo, Finland, July 1–5, 2013, Paper P2.187.

73. A.J. Webster, R.O. Dendy, F.A. Calderon, S.C. Chapman, E. Delabie, D. Dodt, R. Felton, T.N. Todd, V. Riccardo, B. Alper, S. Brezinsek, P. Coad, J. Likonen, M. Rubel, and EFDA-JET Contributors, The Statistics of Edge Localised Plasma Instabilities, 40th European Physical Society Conference on Plasma Physics, Espoo, Finland, July 1–5, 2013, Paper P4.112.
74. F. Koechl, R. Albanese, R. Ambrosino, E. Militello-Asp, P. Belo, G. Corrigan, L. Garzotti, D. Harting, G. Huysmans, T. Koskela, P.T. Lang, J. Lönnroth, E. de la Luna, M. Mattei, F. Maviglia, V. Parail, F. Rimini, M. Romanelli, G. Saibene, E.R. Solano, M. Valovič, I. Voitsekhovitch, A. Webster, JET EFDA contributors, 40th European Physical Society Conference on Plasma Physics, Espoo, Finland, July 1–5, 2013, Integrated core+edge+SOL+MHD modelling of ELM mitigation at JET, Paper P4.116.
75. S. Äkäslompolo, G. Bonheure and G. Tardini, ASCOT simulation of fusion product activation probe experiment in ASDEX Upgrade tokamak, 40th European Physical Society Conference on Plasma Physics, Espoo, Finland, July 1–5, 2013, Paper P5.101.
76. L. Aho-Mantila, M. Bernert, S. Brezinsek, C. Lowry, S. Marsen, K. McCormick, W. Müller, S. Potzel, M. Wischmeier, the ASDEX Upgrade Team, the JET-EFDA Contributors, Radiative L-mode Edge Plasma Regimes in JET and ASDEX Upgrade, 55th Annual Meeting of the APS Division of Plasma Physics, Denver, Colorado, November 11–15, 2013.

6.5 Fusion technology

6.5.1 Publications in scientific journals

77. V. Philipps, A. Malaquias, A. Hakola, J. Karhunen, G. Maddaluno, S. Almaguer, L. Caneve, F. Colao, E. Fortuna, P. Gasior, M. Kubkowska, A. Czarnecka, M. Laan, A. Lissovski, P. Paris, H.J. van der Meiden, P. Petersson, M. Rubel, A. Huber, M. Zlobinski, B., Development of laser-based techniques for in situ characterization of the first wall in ITER and future fusion devices, *Nuclear Fusion* **53** (2013) 093002.
78. E. Zarkadoula, M.T. Dove, K. Trachenko, S.L. Daraszewicz, D.M. Duffy, M. Seaton, I.T. Todorov, and K. Nordlund, The nature of high-energy radiation damage in iron, *Journal of Physics: Condensed Matter* **25** (2013) 125402.
79. K.O.E. Henriksson, C. Björkas, and K. Nordlund, Enabling atomistic simulations of stainless steels: A bond-order potential for Fe-Cr-C system, *Journal of Physics: Condensed Matter* **25** (2013) 445401.
80. A.E. Sand, S.L. Dudarev and K. Nordlund, High energy collision cascades in tungsten: dislocation loops structure and clustering scaling laws, *Europhysics Letters* **103** (2013) 46003.
81. M. Backman, M. Toulemonde, O.H. Pakarinen, N. Juslin, F. Djurabekova, K. Nordlund, A. Debelle and W.J. Weber, Molecular dynamics simulations of swift heavy ion induced defect recovery in SiC, *Computational Materials Science* **67** (2013) 261.
82. H. Meiden, M. Berg, S. Brons, H. Ding, H. Eck, M. Hoen, J. Karhunen, T. Kruif, M. Laan, C. Li, A. Lissovski, T. Morgan, P. Paris, K. Piip, M. Pol, R. Scannell, J. Scholten, P. Smeets, C. Spork, P. Emmichoven, R. Zoomers and G. De Temmerman, Laser-based diagnostics applications for plasma-surface interaction studies. *Journal of Instrumentation* **8** (2013) C11011.

83. H. Rimminen and J. Kynäräinen, Note: Readout of a micromechanical magnetometer for the ITER fusion reactor, *Review of Scientific Instruments* **84** (2013) 056110.
84. Y.-N. Liu, X. Shu, Y. Yu, Guang-Hong, X.-C. Li, T. Ahlgren, L. Bukonte and K. Nordlund, Mechanism of vacancy formation induced by hydrogen in tungsten, *AIP Advances* **3** (2013) 122111.
85. L. Bukonte, F. Djurabekova, J. Samela, K. Nordlund, S.A. Norris and M.J. Aziz, Comparison of molecular dynamics and binary collision approximation simulations for atom displacement analysis, *Nuclear Instruments and Methods in Physics Research B* **297** (2013) 23.
86. M. Backman, F. Djurabekova, O.H. Pakarinen, K. Nordlund, Y. Zhang, M. Toulemonde, and W.J. Weber, Atomistic simulations of MeV ion irradiation of silica, *Nuclear Instruments and Methods in Physics Research B* **303** (2013) 129.
87. M. Rieth, et al. (incl. T. Ahlgren, K. Heinola and K. Nordlund), Recent progress in research on tungsten materials for nuclear fusion applications in Europe, *Journal of Nuclear Materials* **432** (2013) 482.
88. H. Bergsäter, P. Petersson, I. Bykov, G. Possnert, J. Likonen, S. Koivuranta, J.P. Coad, A.M. Widdowson and JET EFDA contributors, Microanalysis of deposited layers in the divertor of JET following operations with carbon wall, *Journal of Nuclear Materials* **438** (2013) S668–S672.
89. S. Koivuranta, J. Likonen, A. Hakola, J.P. Coad, A. Widdowson, D.E. Hole, M. Rubel and JET-EFDA contributors, Post-mortem measurements on fuel retention at JET in 2007–2009 experimental campaign, *Journal of Nuclear Materials* **438** (2013) S735–S737.
90. S. Krat, J.P. Coad, Yu. Gasparyan, A. Hakola, J. Likonen, M. Mayer, A. Pisarev, A. Widdowson, and JET-EFDA contributors, Erosion and deposition on JET divertor and limiter tiles during the discharge campaigns 2004–2009, *Journal of Nuclear Materials* **438** (2013) S742–S745.
91. M. Mayer, S. Krat, J.P. Coad, A. Hakola, J. Likonen, S. Lindig, A. Widdowson, and JET-EFDA contributors, Erosion at the inner wall of JET during the discharge campaigns 2001–2009, *Journal of Nuclear Materials* **438** (2013) S780–S783.
92. A.M. Widdowson, C.F. Ayres, S. Booth, J.P. Coad, D. Ivanova, J. Likonen, M. Mayer, M. Stamp and JET-EFDA contributors, Comparison of JET main chamber erosion with dust collected in the divertor, *Journal of Nuclear Materials* **438** (2013) S827–S832.
93. A. Malaquias, V. Philipps, A. Huber, A. Hakola, J. Likonen, J. Kolehmainen, S. Tervakangas, M. Aints, P. Paris, M. Laan, A. Lissovski, S. Almviva, L. Caneve, F. Colao, G. Maddaluno, M. Kubkowska, P. Gasior, H.J. van der Meiden, A.R. Lof, P.A. Zeijlmans van Emmichoven, P. Petersson, M. Rubel, E. Fortuna and Q. Xiao, Development of ITER relevant laser techniques for deposited layer characterisation and tritium inventory, *Journal of Nuclear Materials* **438** (2013) S936–S939.
94. L. Marot, E. Meyer, M. Rubel, D. Ivanova, A. Widdowson, P. Coad, J. Likonen, A. Hakola, S. Koivuranta, G. De Temmerman and JET-EFDA Contributors, Performances of Rh and Mo Mirrors Under JET Exposure, *Journal of Nuclear Materials* **438** (2013) S1187–S1191.
95. M. Rubel, J.P. Coad, A. Widdowson, G.F. Matthews, H.G. Esser, T. Hirai, J. Likonen, J. Linke, C.P. Lungu, M. Mayer, L. Pedrick, C. Ruset, JET-EFDA Contributors, Overview of erosion–deposition diagnostic tools for the ITER-Like Wall in the JET tokamak, *Journal of Nuclear Materials* **438** (2013) S1204–S1207.

96. D. Ivanova, J. Likonen, A. Widdowson, J.P. Coad, M. Rubel, G. De Temmerman and JET- EFDA Contributors, Assessment of cleaning methods for first mirrors tested in JET for ITER, *Journal of Nuclear Materials* **438** (2013) S1241–S1244.
97. L. Malerba, G. Bonny, D. Terentyev, E.E. Zhurkin, M. Hou, K. Vörtler and K. Nordlund, Microchemical effects in irradiated Fe-Cr alloys as revealed by atomistic simulation, *Journal of Nuclear Materials* **442** (2013) 486.
98. V. Jansson and L. Malerba, Simulation of the nanostructure evolution under irradiation in Fe-C alloys, *Journal of Nuclear Materials* **443** (2013) 274–285.
99. C. Reux, M. Lehnen, U. Kruezi, S. Jachmich, P. Card, K. Heinola, E. Joffrin, P.J. Lomas, S. Marsen, G. Matthews, V. Riccardo, F. Rimini, P. de Vries and JET-EFDA Contributors, Use of the disruption mitigation valve in closed loop for routine protection at JET, *Fusion Engineering and Design* **88** (2013) 1101.
100. P. Alho, J. Mattila, Breaking down the requirements: Reliability in remote handling software, *Fusion Engineering and Design* **88** (2013) 1912–1915.
101. J. Väyrynen, J. Mattila, Reliability requirements management for ITER Remote Handling maintenance systems, *Fusion Engineering and Design* **88** (2013) 1920–1923.
102. J. Tuominen, T. Rasi, J. Mattila, M. Siuko, S. Esque, D. Hamilton, Interoperability of Remote Handling Control System Software Modules at DTP2 Using Middleware, *Fusion Engineering and Design* **88** (2013) 2177–2180.
103. V. Lyytikäinen, P. Kinnunen, J. Koivumäki, J. Mattila, M. Siuko, S. Esque, J. Palmer, Divertor cassette locking system remote handling trials with WHMAN at DTP2, *Fusion Engineering and Design* **88** (2013) 2181–2185.
104. R. Sibois, K. Salminen, M. Siuko, J. Mattila, T. Määttä, Enhancement of the use of digital mock-ups in the verification and validation process for ITER remote handling systems, *Fusion Engineering and Design* **88** (2013) 2190–2193.
105. L. Thomé, A. Debelle, F. Garrido, S. Mylonas, B. Décamps, C. Bachelet, G. Sattonnay, S. Moll, S. Pellegrino, S. Miro, P. Trocellier, Y. Serruys, G. Velisa, C. Grygiel, I. Monnet, M. Toulemonde, P. Simon, J. Jagielski, I. Jozwik-Biala, L. Nowicki, M. Behar, W. Weber, Y. Zhang, M. Backman, K. Nordlund, and F. Djurabekova, Radiation Effects in Nuclear Materials: Role of Nuclear and Electronic Energy Losses and their Synergy, *Nuclear Instruments and Methods in Physics Research B*, accepted.
106. A.E. Sand, K. Nordlund, S.L. Dudarev, Radiation damage production in massive cascades initiated by fusion neutrons in tungsten, *Journal of Nuclear Materials*, accepted.
107. J.P. Coad, E. Alves, C.F. Ayres, N. Baradas, A. Baron-Wiechec, K. Heinola, J. Likonen, G.F. Matthews, A. Widdowson and JET-EFDA contributors, Surface analysis of tiles and samples exposed to the first JET campaigns with the ITER-Like Wall, *Physica Scripta*, accepted.
108. K. Heinola, C.F. Ayres, A. Baron-Wiechec, J.P. Coad, J. Likonen, G.F. Matthews, A. Widdowson and JET-EFDA contributors, Tile profiling analysis of samples from JET ITER-like wall and carbon wall, *Physica Scripta*, accepted.
109. D. Ivanova, A. Widdowson, P. Petersson, M. Rubel, E. Alves, J.P. Coad, A. Garcia-Carrasco, J. Likonen, L. Marot, G. Pintsuk and JET EFDA Contributors, An overview of the Comprehensive First Mirrors Test in JET with ITER-Like Wall, *Physica Scripta*, accepted.
110. J. Karhunen, A. Hakola, J. Likonen, A. Lissovski, P. Paris, M. Laan, C.P. Lungu, K. Sugiyama, Development of Laser-Induced Breakdown Spectroscopy for Analyzing Deposited Layers in ITER, *Physica Scripta*, accepted.

111. S. Koivuranta, J. Likonen, A. Hakola, J.P. Coad, A. Widdowson, D.E. Hole, M. Rubel and JET-EFDA contributors, Post-mortem measurements on fuel retention at JET, *Physica Scripta*, accepted.
112. J. Likonen, A. Hakola, S. Koivuranta, E. Alves, A. Baron-Wiechec, S. Brezinsek, J.P. Coad, G.F. Matthews, P. Petersson, M. Rubel, A. Widdowson and JET-EFDA contributors, First results and surface analysis strategy for plasma-facing components after JET operation with the ITER-like Wall, *Physica Scripta*, accepted.
113. P. Batistoni, D. Barbier, J. Likonen and JET-EFDA Contributors, Fusion technology activities at JET in support of the ITER program, *Fusion Engineering and Design*, accepted.
114. K.O.E. Henriksson and K. Nordlund, Mechanical and elastic changes in cementite Fe₃C subjected to cumulative 1 keV Fe recoils, *Journal of Nuclear Materials*, submitted.
115. C. Stan-Sion, M. Enachescu, A. Petre, M. Duma, D.G. Ghita, G. Kizane, L. Baumane, J. Gabruesnoks, M. Halitovs, L. Avotina, A. Zarins, J. Likonen, S. Koivuranta, M. Kiisk and JET-EFDA contributors, Intercomparison of AMS and FC measurements of tritium in laser cleaned tile, *Fusion Engineering and Design*, submitted.
116. A. Widdowson, E. Alves, C.F. Ayres, A. Baron-Wiechec, S. Brezinsek, J.P. Coad, K. Heinola, J. Likonen, G.F. Matthews, M. Rubel and JET-EFDA contributors, Material Migration Patterns and Overview of First Surface Analysis of the JET ITER-like Wall, *Physica Scripta*, accepted.

6.5.2 Conference articles – fusion technology

117. K. Piip, P. Paris, A. Hakola, K. Bystrov, G. De Temmerman, M. Aints, I. Jõgi, J. Kozlova, M. Laan, J. Likonen, A. Lissovski, H. Mändar. Influence of He/D₂ plasma fluxes on tungsten coatings morphology and crystallinity. Book of Abstracts International Conference Functional Materials and Nanotechnologies: Conference FM&NT-2013, Tartu, Estonia, 21–24 April 2013.
118. P. Petersson, M. Rubel, G. Possnert, S. Brezinsek, A. Hakola, M. Mayer, V. Rohde, Transport and retention studies in tokamaks using ¹⁵N tracer gas, 14th International Workshop on Plasma-Facing Materials and Components for Fusion Applications, Jülich, Germany, May 13–17, 2013, Paper I8.
119. A. Widdowson, E. Alves, C.F. Ayres, A. Baron-Wiechec, S. Brezinsek, J.P. Coad, K. Heinola, J. Likonen, G.F. Matthews, M. Rubel and JET-EFDA contributors, Material Migration Patterns and Overview of First Surface Analysis of the JET ITER-like Wall, 14th International Workshop on Plasma-Facing Materials and Components for Fusion Applications, Jülich, Germany, May 13–17, 2013, Paper I15.
120. D. Borodin, S. Brezinsek, J. Miettunen, M. Stamp, A. Kirschner, C. Björkas, M. Groth, S. Marsen, S. Lisgo, D. Matveev, M. Airila, V. Philipps and JET EFDA Contributors, Determination of Be sputtering yields from spectroscopic observations at the JET ILW based on 3D ERO modelling, 14th International Workshop on Plasma-Facing Materials and Components for Fusion Applications, Jülich, Germany, May 13–17, 2013, Paper I16.
121. K. Piip, P. Paris, A. Hakola, K. Bystrov, G. De Temmerman, M. Aints, I. Jõgi, J. Kozlova, M. Laan, J. Likonen and A. Lissovski, Influence of He/D₂ plasma fluxes on tungsten marker coatings, 14th International Workshop on Plasma-Facing Materials and Components for Fusion Applications, Jülich, Germany, May 13–17, 2013, Paper A023.

122. J. Karhunen, A. Hakola, J. Likonen, A. Lissovski, P. Paris, M. Laan, C.P. Lungu, K. Sugiyama, Development of Laser-Induced Breakdown Spectroscopy for Analyzing Deposited Layers in ITER, 14th International Workshop on Plasma-Facing Materials and Components for Fusion Applications, Jülich, Germany, May 13–17, 2013, Paper A093.
123. A. Hakola, J. Karhunen, S. Koivuranta, J. Likonen, M. Balden, A. Herrmann, M. Mayer, H.W. Müller, R. Neu, V. Rohde, K. Sugiyama, and the ASDEX Upgrade team, Long-term erosion of plasma-facing materials with different surface roughness in ASDEX Upgrade, 14th International Workshop on Plasma-Facing Materials and Components for Fusion Applications, Jülich, Germany, May 13–17, 2013, Paper A094.
124. M. Wisse, L. Marot, A. Widdowson, M. Rubel, D. Ivanova, R.P. Doerner, M.J. Baldwin, J. Likonen, E. Alves, R. Steiner, E. Meyer and EFDA JET Contributors, Laser cleaning of beryllium-containing first mirror samples from JET and PISCES-B, 14th International Workshop on Plasma-Facing Materials and Components for Fusion Applications, Jülich, Germany, May 13–17, 2013, Paper A101.
125. C.P. Lungu, C. Porosnicu, I. Jepu, I. Tiseanu, T. Craciunescu, C. Dobrea, M. Lungu, J. Likonen, A. Hakola, S. Koivuranta, and JET-EFDA contributors, Post-mortem analyses of selected samples from the JET divertor tiles exposed in 2007–2009, 14th International Workshop on Plasma-Facing Materials and Components for Fusion Applications, Jülich, Germany, May 13–17, 2013, Paper A124.
126. H. Bergsäter, I. Bykov, P. Petersson, G. Possnert, J. Likonen, S. Koivuranta, J.P. Coad, A.M. Widdowson and JET EFDA contributors, Microstructure and inhomogenous fuel trapping at divertor surfaces in JET, 14th International Workshop on Plasma-Facing Materials and Components for Fusion Applications, Jülich, Germany, May 13–17, 2013, Paper A129.
127. S. Koivuranta, J. Likonen, A. Hakola, J.P. Coad, A. Widdowson, D.E. Hole, M. Rubel and JET-EFDA contributors, Post-mortem measurements on fuel retention at JET, 14th International Workshop on Plasma-Facing Materials and Components for Fusion Applications, Jülich, Germany, May 13–17, 2013, Paper A147.
128. J. Likonen, A. Hakola, S. Koivuranta, E. Alves, A. Baron-Wiechec, S. Brezinsek, J.P. Coad, G.F. Matthews, P. Petersson, M. Rubel, A. Widdowson and JET-EFDA contributors, Surface analysis strategy for the ITER-like Wall, 14th International Workshop on Plasma-Facing Materials and Components for Fusion Applications, Jülich, Germany, May 13–17, 2013, Paper A149.
129. K. Heinola, C.F. Ayres, A. Baron-Wiechec, J.P. Coad, J. Likonen, G.F. Matthews, A. Widdowson and JET-EFDA contributors, Tile profiler and gravimetric analysis of samples from JET ITER-like Wall and carbon wall, 14th International Workshop on Plasma-Facing Materials and Components for Fusion Applications, Jülich, Germany, May 13–17, 2013, Paper A164.
130. D. Ivanova, A. Widdowson, P. Petersson, M. Rubel, E. Alves, J.P. Coad, A. Garcia-Carrasco, J. Likonen, L. Marot, G. Pintsuk and JET EFDA Contributors, An overview of the Comprehensive First Mirrors Test in JET with ITER-Like Wall, 14th International Workshop on Plasma-Facing Materials and Components for Fusion Applications, Jülich, Germany, May 13–17, 2013, Paper C12.
131. J.P. Coad, E. Alves, C.F. Ayres, N. Baradas, A. Baron-Wiechec, K. Heinola, J. Likonen, G.F. Matthews, A. Widdowson and JET-EFDA contributors, Surface analysis of tiles and samples exposed to the first JET campaigns with the ITER-Like Wall, 14th International Workshop on Plasma-Facing Materials and Components for Fusion Applications, Jülich, Germany, May 13–17, 2013, Paper C17.

132. R. Sibois, T. Määttä, M. Siuko and J. Mattila, Early Design Verification of ITER Remote Handling Systems using Digital Mock-Ups within Simulation Lifecycle Environment, 25th Symposium on Fusion Engineering, San Francisco, USA, June 11–14, 2013.
133. K. Piip, M. Laan, P. Paris, M. Aints, A. Hakola, J. Karhunen, J. Likonen, A. Lissovski, P. Petersson and M. Rubel, First Wall Monitoring by LIBS: Options and Limitations, 40th European Physical Society Conference on Plasma Physics (Satellite Meeting on Diagnostics), Espoo, Finland, July 6, 2013, Paper O6.503.
134. J. Karhunen, A. Hakola, J. Likonen, A. Lissovski, P. Paris, M. Laan, C. Porosnicu, C.P. Lungu and K. Sugiyama, Optimisation of LIBS parameters for analyzing co-deposited layers in ITER, 40th European Physical Society Conference on Plasma Physics, Espoo, Finland, July 1–5, 2013, Paper P5.108.
135. P. Alho, J. Mattila, Software Fault Detection and Recovery in Critical Real-Time Systems: an Empirical Study, 11th International Symposium on Fusion Nuclear Technology, Barcelona, Spain, September 16–20, 2013.
136. R. Sibois, T. Määttä, M. Siuko, and J. Mattila, Simulation-based design process for the Verification of ITER Remote Handling Systems, Proceedings of the 11th International Symposium on Fusion Nuclear Technology (ISFNT), Barcelona, Spain, September 16–20, 2013.
137. J. Tuominen, M. Viinikainen, P. Alho, J. Mattila, Using a data centric event-driven architecture approach in the integration of real-time systems at DTP2, 11th International Symposium on Fusion Nuclear Technology, Barcelona, Spain, September 16–20, 2013.
138. M. Viinikainen, J. Tuominen, P. Alho, J. Mattila, Improving the performance of DTP2 bilateral teleoperation control system with haptic augmentation, 11th International Symposium on Fusion Nuclear Technology, Barcelona, Spain, September 16–20, 2013.
139. J. Väyrynen, P. Alho, J. Mattila, Reliability Requirements Management – addressing Remote Handling controller reliability via probabilistic methods, 11th International Symposium on Fusion Nuclear Technology, Barcelona, Spain, September 16–20, 2013.

6.5.3 Research reports – fusion technology

140. K. Heinola, Photographic survey on IWGL 2X and 5Z beam tile surface features, Follow-on ITER-Like Wall Reports FILW_ST_1230_R012, 16 pp. (2013).
141. Markus Airila and Antti Salmi (eds.), Fusion Yearbook – Association Euratom-Tekes Annual Report 2012, VTT Science **30** (2013).
142. R. Tuominen and T. Ahonen, WP13-DTM02-T02/TEKES: Expert judgment methods for estimating probabilistic quantities, EFDA_D_2KXGMX (2013).
143. T. Ahonen and R. Tuominen, WP13-DTM02-T04/TEKES: Analysis of the DEMO availability requirement, EFDA_D_2KW3HG (2013).
144. D. Carfora, M. Siuko, J. Järvenpää, WP13-DAS07/TEKES: Divertor Remote Maintenance System Pre-concept study, EFDA_2LMWHU (2013).

6.6 Doctoral and graduate theses

145. J-B. Izard, Development of Remote Handling Technologies Tolerant to Operation Ready Fusion Reactor Conditions, Doctoral dissertation, Tampere University of Technology, Tampere 2013.

146. S. Janhunen, Gyrokinetic particle simulation for thermonuclear plasma turbulence studies in magnetic confinement, Aalto University School of Science, Aalto University Doctoral Dissertations 56/2013, Espoo 2013.
147. V. Jansson, Radiation-induced nanostructure evolution models for Fe alloys, Doctoral dissertation, University of Helsinki 2013.
148. A. Pohjonen, Dislocation mechanisms leading to protrusion growth under electric field induced stress on metal surfaces, Doctoral dissertation, University of Helsinki 2013.
149. J. Karhunen, Development of laser-induced breakdown spectroscopy for analyzing deposited layers in ITER, MSc thesis, Aalto University 2013.
150. P. Niskala, Investigating geodesic acoustic modes on the TEXTOR tokamak via gyrokinetic plasma simulations, MSc thesis, Aalto University 2013.
151. P. Sirén, Current density modelling in JET and JT-60U identity plasma experiments, MSc thesis, Aalto University 2013.

Appendix A: Introduction to Fusion Energy

Energy Demand Is Increasing

Most projections show world energy demand doubling or trebling in the next 50 years. This derives from fast population growth and rapid economic development. Energy sources that are not yet fully tapped include biomass, hydropower, geothermal, wind, solar, nuclear fission and fusion. All of them must be developed to meet future needs. Each alternative has its advantages and disadvantages regarding the availability of the resource, its distribution globally, environmental impact, and public acceptability. Fusion is a good candidate for supplying base-load electricity on a large scale. Fusion has practically unlimited fuel resources, and it is safe and environmentally sound.

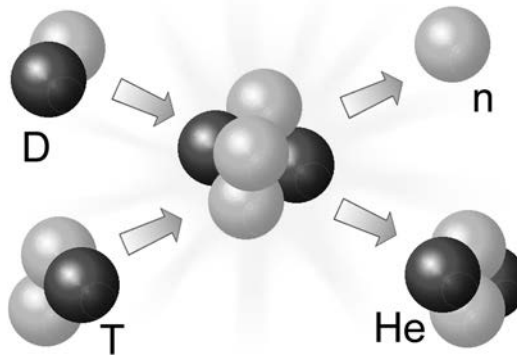

Figure A.1. In a fusion reaction, Deuterium (D) and Tritium (T) fuse together forming a Helium nucleus (${}^4\text{He}$) and releasing a large amount of energy which is mostly carried by a neutron (n).

What Is Fusion Energy?

Fusion is the energy source of the sun and other stars, and all life on Earth is based on fusion energy. The fuels burned in a fusion reactor are hydrogen isotopes, deuterium and tritium. Deuterium resources are practically unlimited, and tritium can be produced from lithium, which is abundant. The fusion reactions occur only at very high temperatures. For the deuterium-tritium reaction, fuel temperatures over 100 million $^{\circ}\text{C}$ are required for sufficient fusion burn. At these temperatures, the fuel gas is fully ionised plasma. High temperatures can be achieved by injecting energetic particle beams or high power radio-frequency (RF) waves into the plasma. The hot plasma can be thermally isolated from the material walls by strong magnetic fields, which form a “magnetic bottle” to confine the fuel plasma.

With a sufficiently large plasma volume, much more energy is released from fusion reactions than is required to heat and confine the fuel plasma, i.e., a large amount of net energy is produced.

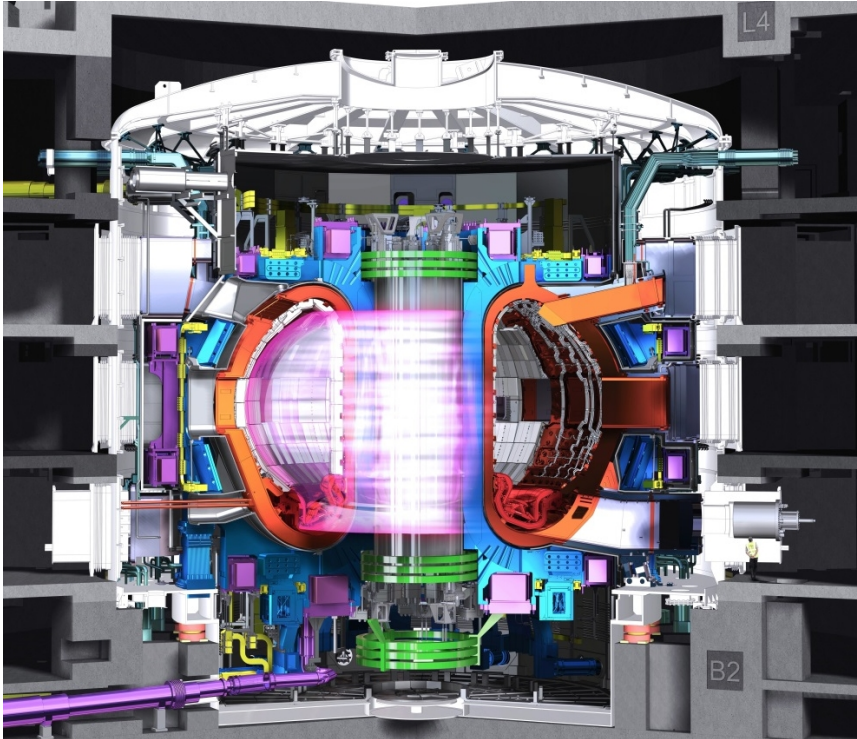

Figure A.2. The Configuration Management Model of the ITER Tokamak, with its plasma, produced by the Design Integration Section in July 2013. Credit © ITER Organization, <http://www.iter.org/>

The European Fusion Programme

Harnessing fusion energy is the primary goal of the Euratom Fusion Programme in the 7th Framework Programme. The reactor orientation of the programme has provided the drive and the cohesion that makes Europe the world leader in fusion research. The world record of 16 megawatts of fusion power is held by JET device, the Joint European Torus.

Euratom Fusion Associations are the backbone of the European Fusion Programme. There are 27 Associations from the EU countries and Switzerland. The multilateral European Fusion Development Agreement (EFDA) between all Associations and Euratom takes care of overall physics co-ordination in Europe, facilitates the joint exploitation of the JET facilities and emerging fusion technologies.

A new organisation “The Joint European Undertaking for ITER and the Development of Fusion Energy, “Fusion for Energy” (F4E) was established in 2007 and came fully operational in 2008. The main task of “Fusion for Energy” is to provide European in-kind contributions for ITER including component and system procurements, services and technology R&D for ITER. In addition, “Fusion for Energy” manages DEMO design activities and the European Broader Approach activities in collaboration with Japan.

ITER International Fusion Energy Organisation

To advance significantly beyond the present generation of fusion devices, a next step device, enabling the investigation of burning plasma in near-reactor conditions, is needed. This will be done in the global ITER project (“iter” is “way” in Latin), which is the joint project of EU, Japan, Russian Federation, United States, China, India and South Korea. The ITER parties agreed in 2005 to site ITER in Europe (Cadarache, France) and the ITER International agreement was signed by the parties in Elysée Palace hosted by the President of France Jacques Chirac, Paris, on 21 November 2006. ITER started as an international legal entity from 27 November 2007. The director general of ITER is Osamu Motojima and head of the ITER project is Remmelt Haange. At the end of 2012 the project staff was about 500 persons and 350 external contractors on-site. The total number of personnel will be close to 600.



Figure A.3. On the morning of 11 December 2013, concrete pouring begins for the basemat of the Tokamak Complex. Six months, and another 14 “pour days” will be necessary to complete the 1.5-metre-thick slab that will support the weight of the Tokamak, Diagnostic and Tritium buildings. Credit © ITER Organization, <http://www.iter.org/>

Appendix B: Institutes and Companies

Research Institutes and Companies

Tekes – The Finnish Funding Agency for Technology and Innovation

Kyllikinportti 2, Länsi-Pasila

P.O. Box 69, FI-00101 Helsinki, Finland

Tel. +358 10 191 480; fax: +358 9694 9196

www.tekes.fi

Juha Lindén juha.linden@tekes.fi

Kari Koskela kari.koskela@tekes.fi

Hannu Juuso hannu.juuso@tekes.fi

Finnish Fusion Research Unit of the Association Euratom-Tekes

VTT Materials for Power Engineering

Otakaari 3A, Espoo and Kemistintie 3, Espoo

P.O. Box 1000, FI-02044 VTT, Finland

Tel. +358 20 722 111; fax: +358 20 722 6390

www.vtt.fi

Tuomas Tala tuomas.tala@vtt.fi

Jukka Heikkinen jukka.heikkinen@vtt.fi

Jari Likonen jari.likonen@vtt.fi

VTT Production Systems

Tuotantokatu 2, Lappeenranta

P.O. Box 17021, FI-53851 Lappeenranta, Finland

Tel. +358 20 722 111; fax: +358 20 722 2893

Veli Kujanpää veli.kujanpaa@vtt.fi

VTT System Engineering

Tekniikankatu 1, Tampere

P.O. Box 1300, FI-33101 Tampere, Finland

Tel. +358 20 722 111; fax: +358 20 722 3495

Jorma Järvenpää jorma.jarvenpaa@vtt.fi

Mikko Siuko mikko.siuko@vtt.fi

VTT Sensors

Tietotie 3, Espoo

P.O. Box 1000, FI-02044 VTT, Finland

Tel. +358 20 722 111; fax: +358 20 722 7012

Jukka Kyynäräinen jukka.kyynarainen@vtt.fi

Aalto University (AU)

School of Science
Department of Applied Physics
P.O. Box 14100, FI-00076 AALTO, Finland
Tel. +358 9 4511; fax: +358 9 451 3195
<http://physics.aalto.fi/groups/fusion>
Mathias Groth mathias.groth@aalto.fi
Taina Kurki-Suonio taina.kurki-suonio@aalto.fi
Rainer Salomaa rainer.salomaa@aalto.fi

Tampere University of Technology (TUT)

Institute of Hydraulics and Automation
Korkeakoulunkatu 2, P.O. Box 589, FI-33101 Tampere, Finland
Tel. +358 3115 2111; fax: +358 3115 2240
www.iha.tut.fi
Matti Vilenius matti.vilenius@tut.fi
Jouni Mattila jouni.mattila@tut.fi

Lappeenranta University of Technology (LUT)

Laboratory of Machine Automation
Skinnarilankatu 34, P.O. Box 20, FI-53851 Lappeenranta, Finland
Tel. + 358 5 621 11; fax: +358 5 621 2350
www.lut.fi
Heikki Handroos heikki.handroos@lut.fi

University of Helsinki (UH)

Accelerator Laboratory
P.O. Box 43, FI-00014 University of Helsinki, Finland
Tel. +358 9 191 40005; fax: +358 9 191 40042
www.beam.helsinki.fi
Juhani Keinonen juhani.keinonen@helsinki.fi
Kai Nordlund kai.nordlund@helsinki.fi

Estonian Research Unit of the Association Euratom-Tekes

University of Tartu (UT)

Institute of Physics
Riia 142
51014 Tartu, Estonia
Tel. +372 742 8493; fax: +372 738 3033
www.fi.tartu.ee
Madis Kiisk madis.kiisk@fi.tartu.ee
Marco Kirm marco.kirm@ut.ee

Industrial Companies

- Company: **ABB Oy**
Technology: Power and automation
Contact: ABB Oy, P.O. Box 184, FI-00381 Helsinki, Finland
Tel. +358-10-2211; fax: +358-10-2222 287
Ralf Granholm, ralf.granholm@fi.abb.com
- Company: **Adwatec Oy**
Technology: Water cooling systems for high power electronics (low, medium and high voltage).
Contact: Adwatec Oy, Artturintie 14H, FI-36220 Tampere, Finland
Tel. +358 3 389 0860; fax: +358 3 389 0861
www.adwatec.com
Arto Verronen, arto.verronen@adwatec.com
- Company: **Aspocomp Oy**
Technology: Electronics manufacturing, thick film technology, component mounting (SMT), mounting of chips (COB) in mechanical/electrical micro systems (MEMS) and multi-chip modules (MCM), PWB (or also called PCB), sheet metal manufacturing and assembly.
Contact: Aspocomp Oy, Yrittäjätie 13, FI-01800 Klaukkala, Finland
Tel. +358 9 878 01244; fax: +358 9 878 01200
www.aspocomp.com
Markku Palmu, markku.palmu@aspocomp.com
- Company: **CLS-Engineering Oy**
Technology: Preliminary engineering, implementation, engineering, field and electrification engineering, manufacturing of automation cabinets and switch-gear, programming, installation, testing, and maintenance services
Contact: CLS-Engineering Oy, Hakunintie 21, FI-26100 Rauma, Finland
Tel. +358 201 549 400; fax: +358 201 549 401
www.cls-engineering.fi
Tom Holmström, tom.holmstrom@cls-engineering.fi
- Company: **Comatec Group (Engineering bureau Comatec Ltd)**
Technology: Engineering design for machinery and industrial equipment. Mobile machinery, production equipment, transportation equipment as well as pressure equipment and boiler plant engineering. Our offering comprises of concept services, project design and management services, design services and expert services.
Contact: Comatec Group, Kalevantie 7C, FI-33100 Tampere, Finland
Tel. +358 29 000 2000
www.comatec.fi
Miikka Riittinen, miikka.riittinen@comatec.fi

- Company: **Creanex Oy**
Technology: Remote handling, teleoperation and walking platforms.
Contact: Creanex Oy, Nuolialantie 62, FI-33900 Tampere, Finland
fax: +358 33683 244, GSM +358 50 311 0300
www.creanex.com
Timo Mustonen, timo.mustonen@creanex.com
- Company: **Delfoi Oy**
Technology: Telerobotics, task level programming
Contact: Delfoi Oy, Vänrikinkuja 2, FI-02600 Espoo, Finland
Tel. +358 9 4300 70; fax: +358 9 4300 7277
www.delfoi.com
Heikki Aalto, heikki.aalto@delfoi.com
- Company: **DIARC-Technology Oy**
Technology: Coatings for plasma facing components. Deuterium doped coatings for hydrogen migration and erosion studies in fusion machines. Cleaning techniques for first wall components.
Contact: DIARC-Technology, Kattilalaaksontie 1, FI-02330 Espoo, Finland
Tel. +358 10 271 2030; fax: +358 10 271 2049
www.diarc.fi
Jukka Kolehmainen, jukka.kolehmainen@diarc.fi
- Company: **Elektrobit Microwave Oy**
Technology: Product development, test solutions and manufacturing for microwave and RF- technologies, high-tech solutions ranging from space equipment to commercial telecommunication systems
Contact: Teollisuustie 9A, FI-02700 Kauniainen, Finland
Tel. +358 40 344 2000; fax: +358 9 5055 547
www.elektrobit.com
Marko Koski, marko.koski@elektrobit.com
- Company: **Elomatic Oy**
Technology: Design and other services for manufactures of machinery and equipment. We are involved in our customer's R&D: in projects, product design and production development.
Contact: Elomatic Oy, Kangasvuorentie 10, FI-40320 Jyväskylä, Finland
Tel. +358 14 446 7111; fax: +358 14 446 7123
www.elomatic.com
Timo Martikainen, timo.martikainen@elomatic.com
- Company: **Etteplan Oyj**
Technology: Etteplan is a specialist in industrial equipment engineering and technical product information solutions and services. Our customers are global leaders in their fields and operate in areas like the au-

- tomotive, aerospace and defence industries as well as the electricity generation and power transmission sectors, and material flow management.
- Contact: Terveystie 18, FI-15860 Hollola, Finland
Tel. +358 10 307 1010
- Company: **Fortum Power and Heat Oy**
Technology: Nuclear Engineering
Contact: P.O. Box 100, FI-00048 Fortum, Finland
Tel. + 358 10 4511
www.fortum.com
Reko Rantamäki, reko.rantamaki@fortum.com
- Company: **Hollming Works Oy**
Technology: Mechanical engineering, fabrication of heavy steel and stainless steel structures, design for manufacturing
Contact: Puunaulakatu 3, P.O. Box 96, FI-28101 Pori, Finland
Tel. +358 20 486 5040; fax: +358 20 486 5041
www.hollmingworks.com
Mika Korhonen, mika.korhonen@hollmingworks.com
- Company: **Hytar Oy**
Technology: Remote handling, water hydraulics
Contact: Turjankatu 1, FI-33100 Tampere, Finland
Tel. +358-10 613 7150
Olli Pohls, olli.pohls@hytar.fi
- Company: **Instrumentti-Mattila Oy**
Technology: Designs and manufacturing of vacuum technology devices
Contact: Valpperintie 263, FI-21270 Nousiainen, Finland
Tel. +358-2-4353611; fax: +358-2-431 8744
www.instrumentti-mattila.fi
Veikko Mattila, veikko.mattila@instrumentti-mattila.fi
- Company: **Japrotek Oy Ab**
Technology: Design and manufacturing of stainless steel and titanium process equipment such as columns, reactors and heat exchangers
Contact: Japrotek Oy Ab, P.O. Box 12, FI-68601, Pietarsaari, Finland
Tel. +358-20 1880 511; fax: +358-20 1880 415
www.vaahto.fi
Ulf Sarelin, ulf.sarelin@vaahto.fi

- Company: **Kempower Oy**
Technology: Designs and manufacturing of standard and customised power sources for industrial and scientific use
Contact: Hennalankatu 39, P.O. Box 13, FI-15801, Lahti, Finland
Tel. +358-3-899 11; fax: +358-3-899-417
www.kempower.fi
Petri Korhonen, petri.korhonen@kempower.fi
- Company: **Luvata Pori Oy**
Technology: Superconducting strands and copper products.
Contact: Luvata Pori Oy, Kuparitie, P.O. Box 60, FI-28101 Pori, Finland
Tel. +358 2 626 6111; fax: +358 2 626 5314
Ben Karlemo, ben.karlemo@luvata.com
- Company: **Mansner Oy Precision Mechanics**
Technology: Precision mechanics: milling, turning, welding, and assembling. From stainless steels to copper.
Contact: Mansner Oy, Yrittäjätie 73, FI-03620 Karkkila, Finland
Tel. +358 20 7862 367; fax: +358 20 7862 363
www.mansner.com
Sami Mansner, sami.mansner@mansner.fi
- Company: **Marimils Oy**
Technology: Evacuation guiding systems and emergency lighting.
Contact: Marimils Oy, Pohjantähdentie 17, FI-01451 Vantaa, Finland
Tel. +358 207 508 615; fax: +358 207 508 601
www.marimils.com
Juha Huovilainen, juha.huovilainen@marimils.fi
- Company: **Marioff Corporation Oy**
Technology: Mist fire protection systems
Contact: Marioff Corporation Oy, P.O. Box 25, FI-01511 Vantaa, Finland
Tel. +358 9 8708 5342; fax: +358 9 8708 5399
www.hi-fog.com
Pekka Saari, pekka.saari@marioff.fi
- Company: **Metso Oyj**
Metso Engineered Materials and Components
Technology: Steel castings, special stainless steels, powder metallurgy, component technology/ engineering, design, production and installation
Contact: Metso Engineered Materials and Components, P.O. Box 306, FI-33101 Tampere, Finland
Tel. +358 20 484 120; fax: +358 20 484 121
www.metsomaterialstechnology.com
Jarmo Lehtonen, jarmo.t.lehtonen@metso.com

- Company: **Oxford Instruments Analytical**
Technology: Plasma diagnostics, vacuum windows
Contact: Nihtisillankuja, P.O. Box 85, FI-02631 Espoo, Finland
Tel. +358 9 329411; fax: +358 9 23941300
www.oxford-instruments.com
Seppo Nenonen, seppo.nenonen@oxinst.fi
- Company: **Patria Oyj**
Technology: Defence and space electronics hardware and engineering
Contact: Patria Oyj, Kaivokatu 10, FI-00100 Helsinki, Finland
Tel. +358-2-435 3611; fax: +358-2-431 8744
www.patria.fi
Tapani Nippala, tapani.nippala@patria.fi
- Company: **Platom Oy**
Technology: UF₆ handling equipment, process modelling and radioactive waste management.
Contact: Platom Oy, Jääkärinkatu 33, FI-50130 Mikkeli, Finland
Tel. +358 44 5504 300; fax: +358 15 369 270
www.platom.fi
Miika Puukko, miika.puukko@platom.fi
- Company: **Powernet Oy**
Technology: Design and manufacturing of custom design power supplies, AC/DC, DC/DC, DC/AC in power ranges from 100–3200W.
Contact: Powernet Oy, Martinkyläntie 43, FI-01720 Vantaa, Finland
Tel. +358-10-2890-700; fax: +358-10-2890-793
Harry Lilja, harry.lilja@powernet.fi
- Company: **PPF Projects Oy**
Service: Marketing and development
Contact: Kaunisreunantie 1, FI-28800 Pori, Finland
Tel. +358 50 40 79 799, +358 2 648 2030
fuusio.ppf.fi
Pertti Pale, pertti.pale@ppf.fi
- Company: **Prizztech Oy**
Role: Characterisation of super conductive and permanent magnet materials. Electromagnetic modelling
Contact: Pohjoisranta 11D, PL 18, FI-28101 Pori, Finland
Tel. +358 44 710 5337
www.prizz.fi
Martti Paju, martti.paju@prizz.fi

Company: **Pöyry Finland Oy**
Technology: Global consulting and engineering expert within the Pöyry Group serving the energy sector. Core areas: nuclear energy, hydro-power, oil & gas, renewable energy, power & heat, transmission & distribution.
Contact: P.O. Box 93, Tekniikantie 4 A, FI-02151 Espoo, Finland
Tel. +358 10 3311
www.poyry.com
Miko Olkkonen, miko.olkkonen@poyry.com

Company: **Rados Technology Oy**
Technology: Dosimetry, waste & contamination and environmental monitoring.
Contact: Rados Technology Oy, P.O. Box 506, FI-20101 Turku, Finland
Tel. +358 2 4684 600; fax: +358 2 4684 601
www.rados.fi
Erik Lehtonen, erik.lehtonen@rados.fi

Company: **Rejlers Oy**
Technology: Services for industry, energy, building & property and infra customers. Core expertise: electricity and automation, mechanical engineering, plant engineering, FE modelling and analysis. Also more comprehensive project deliveries as turn-key basis.
Contact: Rejlers Oy, P.O. Box 194, FI-50101 Mikkeli, Finland
Tel. +358 20 7520 700; fax: +358 20 7520 701
www.rejlers.fi
Seppo Sorri, seppo.sorri@rejlers.fi

Company: **Rocla Oyj**
Technology: Heavy Automated guided vehicles
Contact: Rocla Oyj, P.O. Box 88, FI-04401 Järvenpää, Finland
Tel. +358 9 271 471; fax: +358 9 271 47 430
www.rocla.fi
Pekka Joensuu, pekka.joensuu@rocla.com

Company: **Selmic Oy**
Technology: Microelectronics design and manufacturing, packaging technologies and contract manufacturing services.
Contact: Selmic Oy, Vanha Porvoontie 229, FI-01380 Vantaa, Finland
Tel. +358 9 2706 3911; fax: +358 9 2705 2602
www.selmic.com
Patrick Sederholm, patrick.sederholm@selmic.com

- Company: **Space Systems Finland Ltd.**
Technology: Safety critical systems development; safety assessments and qualification of systems for use in nuclear power plants.
Contact: Kappelitie 6 B, FI-02200 Espoo, Finland
Tel. +358 9 6132 8600; fax: +358 9 6132 8699
www.ssf.fi
Timo Latvala, timo.latvala@ssf.fi
- Company: **Solving Oy**
Technology: Heavy automated guided vehicles. Equipment for heavy assembly and material handling based on air film technology for weights up to hundreds of tons.
Contact: Solving Oy, P.O. Box 98, FI-68601 Pietarsaari, Finland
Tel. +358 6 781 7500; fax: +358 6 781 7510
www.solving.com
Bo-Göran Eriksson, bo-goran.eriksson@solving.com
- Company: **SWECO Industry Oy**
Technology: Consulting and engineering company operating world-wide, providing consulting, engineering and project management services for industrial customers in plant investments, product development and production.
Contact: Valimotie 9, P.O. Box 75, FI-00381 Helsinki, Finland
Tel. +358 20 752 6000
Kari Harsunen, kari.harsunen@sweco.fi
- Company: **Tampereen Keskustekniikka Oy**
Technology: Product development, design, production, marketing, and sales of switchgear and controlgear assemblies.
Contact: Hyllilänkatu 15, P.O. Box 11, FI-33731 Tampere, Finland
Tel. +358-3-233 8331
www.keskustekniikka.fi
Reijo Anttila, reijo.anttila@keskustekniikka.fi
- Company: **Tankki Oy**
Technology: Production and engineering of stainless steel tanks and vessels for use in different types of industrial installations
Contact: Oikotie 2, FI-63700 Ähtäri, Finland
Tel. +358 6 510 1249; fax: +358 6 510 1200
www.tankki.fi
Arto Raikunen, arto.raikunen@tankki.fi

- Company: **TVO Nuclear Services Oy**
Technology: Nuclear power technologies; service, maintenance, radiation protection and safety.
Contact: Olkiluoto, FI-27160 Eurajoki,
Tel. + 358 2 83 811; fax: +358 2 8381 2109
www.tvons.fi
Mikko Leppälä, mikko.leppala@tvo.fi
- Company: **Oy Woikoski Ab**
Technology: Production, development, applications and distribution of gases and liquid helium
Contact: Voikoski, P.O. Box 1, FI-45371 Valkeala, Finland
Tel. +358-15-7700700 fax: +358-15-7700720
www.woikoski.fi
Kalevi Korjala, kalevi.korjala@woikoski.fi
- Company: **ÅF-Consult Oy**
Technology: Design, engineering, consulting and project management services in the field of power generation and district heating. EPCM services.
Contact: FI-02600 Espoo, Finland
Tel. +358 40 348 5511; fax: +358 9 3487 0810
www.afconsult.com
Jarmo Raussi, jarmo.raussi@afconsult.com

Title	Fusion Yearbook Association Euratom-Tekes Annual Report 2013
Author(s)	Markus Airila & Antti Hakola (eds.)
Abstract	<p>This Annual Report summarises the fusion research activities of the Finnish and Estonian Research Units of the Association Euratom-Tekes in 2013. The emphasis of the work coordinated by EFDA was in ITER Physics, PPPT and the ITM Task Force. Other EFDA activities in 2013 were carried out within Goal Oriented Training and EFDA Fellowship. In addition, a significant fraction of Tekes activities was directed to F4E grants and ITER contracts.</p> <p>Fusion physics work is carried out at VTT, Aalto University (AU), University of Helsinki (UH) and University of Tartu (UT). The main activities are plasma experiments in collaboration with tokamak laboratories, modelling and code development, and diagnostics related to the main European fusion facilities JET and AUG. In particular, Association Euratom-Tekes focused on (i) Heat and particle transport and fast particle studies, (ii) Plasma-wall interactions and material transport in the scrape-off layer, and (iii) Development of simulation codes and their integration into the ITM environment.</p> <p>The Association participated in the EFDA JET Workprogramme 2013, including C31 experiments with the ITER-like wall, edge and core modelling, diagnostics development and code integration. Three physicists were seconded to the JET operating team and one to EFDA CSU. The Association participated also in the 2013 experimental programme of ASDEX Upgrade at IPP and the analysis of DIII-D and C-Mod data.</p> <p>Technology work is carried out at VTT, AU and Tampere University of Technology (TUT) in close collaboration with Finnish industry. Industrial participation is coordinated by Tekes. The technology research and development includes the DTP2 facility at VTT Tampere, materials and joining techniques, vessel/in-vessel components, magnetic diagnostics for ITER by micromechanical magnetometers, upgrading of the JET NPA diagnostics, Power Plant Physics and Technology (PPPT) activities, plasma facing materials issues, erosion/re-deposition and material transport studies and development of coating techniques.</p> <p>Association Euratom-Tekes is involved in Goal-Oriented Training in Remote Handling project, coordinated by Tampere University of Technology. In July 2013, the 40th EPS Plasma Physics Conference, organized by AU, gathered over 600 participants in Espoo.</p>
ISBN, ISSN	ISBN 978-951-38-8121-4 (Soft back ed.) ISBN 978-951-38-8122-1 (URL: http://www.vtt.fi/publications/index.jsp) ISSN-L 2242-119X ISSN 2242-119X (Print) ISSN 2242-1203 (Online)
Date	April 2013
Language	Finnish, English abstract
Pages	162 p. + app. 13 p.
Name of the project	
Commissioned by	Tekes, Euratom
Keywords	Nuclear fusion, fusion energy, fusion research, fusion physics, fusion technology, fusion reactors, fusion reactor materials, ITER remote handling, Euratom
Publisher	VTT Technical Research Centre of Finland P.O. Box 1000, FI-02044 VTT, Finland, Tel. +358 20 722 111

Nimeke	Fuusio-vuosikirja Euratom-Tekes-assosiaation vuosikertomus 2013
Tekijä(t)	Markus Airila & Antti Hakola (toim.)
Tiivistelmä	<p>Tähän vuosikirjaan on koottu Suomen ja Viron fuusiotutkimusyksiköiden vuoden 2013 tulokset ja saavutukset. Työ on tehty Euratom-Tekes-assosiaation puitteissa. EFDAn koordinoima työ keskittyi ITERin fysiikkaan, DEMOn fysiikkaan ja tekniikkaan (power plant physics and technology, PPPT) ja integroituun mallinnukseen (integrated tokamak modelling, ITM). EFDA-työtä tehtiin vuonna 2013 uusien asiantuntijoiden koulutuksessa (goal oriented training in remote handling, GOTRH, ja EFDA Fellowship). Tampereen teknillinen yliopisto oli koordinoitivastuussa GOTRH-projektissa. F4E-organisaation myöntämällä rahoituksella ja ITER-sopimuksilla on ohjelmassa merkittävä osuus.</p> <p>Fysiikan tutkimusta tehdään VTT:llä, Aalto-yliopistossa, Helsingin yliopistossa sekä Tarton yliopistossa, ja se keskittyy plasmakokeisiin yhteistyössä tokamak-laboratorioiden kanssa ja niiden mallinnukseen. Assosiaation erityisiä painopiste-alueita ovat (i) Lämmön ja hiukkasten kuljetus ja nopeiden hiukkasten fysiikka, (ii) Plasma-seinäma-vuorovaikutukset ja materiaalien kulkeutuminen kuorintakerrok-sessa sekä (iii) Simulointiohjelmistojen kehitys ja integrointi ITM-ympäristöön.</p> <p>Vuonna 2013 Euratom-Tekes-assosiaatio osallistui EFDA-JETin koekampan-jaan C31, reuna- ja sydänplasman mallinnukseen, diagnostiikan kehitykseen ja simulointiohjelmien integrointiin. Kolme fyysikkoo toimi JETin käyttöorganisaatiossa ja yksi EFDAn tukiorganisaatiossa (close support unit, CSU). Lisäksi assosiaatio osallistui ASDEX Upgrade -tokamakin vuoden 2013 koeohjelmaan sekä DIII-D- ja C-Mod-tokamakin tulosten analysointiin.</p> <p>Teknologiatyötä tekevät VTT, Aalto-yliopisto ja LTY tiiviissä yhteistyössä suomalaisen teollisuuden kanssa. Yritysten osallistumista koordinoi Tekes. Kehitettä-viin teknologioihin kuuluvat DTP2-laitteisto VTT:llä Tampereella, materiaalit ja niiden liitostekniikat, tyhjiökammioon liittyvät komponentit, MEMS-pohjaisten diag-nostiikkojen kehitys ITERin magneettikenttien mittausta varten, JETin NPA-diagnostiikan päivitys, osallistuminen PPPT-tutkimukseen, ensiseinäman materiaa-lit, eroosion, deposition ja materiaalien kulkeutumisen tutkimus sekä pinnoitteiden kehittäminen.</p> <p>Heinäkuussa 2013 Aalto-yliopisto järjesti Dipolissa Espoossa kiittävää palautetta saaneen EPS:n plasmafysiikan konferenssin, johon osallistui yli 600 fyysikkoo.</p>
ISBN, ISSN	ISBN 978-951-38-8121-4 (nid.) ISBN 978-951-38-8122-1 (URL: http://www.vtt.fi/publications/index.jsp) ISSN-L 2242-119X ISSN 2242-119X (painettu) ISSN 2242-1203 (verkkojulkaisu)
Julkaisu-aika	Huhtikuu 2013
Kieli	Englanti, suomenkielinen tiivistelmä
Sivumäärä	162 s. + liitt. 13 s.
Projektin nimi	
Toimeksiantajat	Tekes, Euratom
Avainsanat	Nuclear fusion, fusion energy, fusion research, fusion physics, fusion technology, fusion reactors, fusion reactor materials, ITER remote handling, Euratom
Julkaisija	VTT PL 1000, 02044 VTT, puh. 020 722 111



Fusion Yearbook

Association Euratom-Tekes

Annual Report 2013

This Annual Report summarises the fusion research activities of the Finnish and Estonian Research Units of the Association Euratom-Tekes in 2013.

Fusion physics work is carried out at VTT, Aalto University, University of Helsinki and University of Tartu. The main activities are plasma experiments in collaboration with tokamak laboratories, modelling and code development, and diagnostics related to the main European fusion facilities JET and AUG. In particular, Association Euratom-Tekes focused on (i) Heat and particle transport and fast particle studies, (ii) Plasma-wall interactions and material transport in the scrape-off layer, and (iii) Development of simulation codes and their integration into the ITM environment.

Technology work is carried out at VTT, Aalto University and Tampere University of Technology in close collaboration with Finnish industry. Industrial participation is co-ordinated by Tekes. The technology research and development includes the DTP2 facility at VTT Tampere, materials and joining techniques, vessel/in-vessel components, magnetic diagnostics for ITER by micromechanical magnetometers, upgrading of the JET NPA diagnostics, Power Plant Physics and Technology (PPPT) activities, plasma facing materials issues, erosion/re-deposition and material transport studies and development of coating techniques.

A particular highlight in 2013 was the 40th EPS Plasma Physics Conference, organized by Aalto University, that gathered over 600 participants in Espoo in July.

ISBN 978-951-38-8121-4 (Soft back ed.)
ISBN 978-951-38-8122-1 (URL: <http://www.vtt.fi/publications/index.jsp>)
ISSN-L 2242-119X
ISSN 2242-119X (Print)
ISSN 2242-1203 (Online)

