

0110
1010
0101
1100

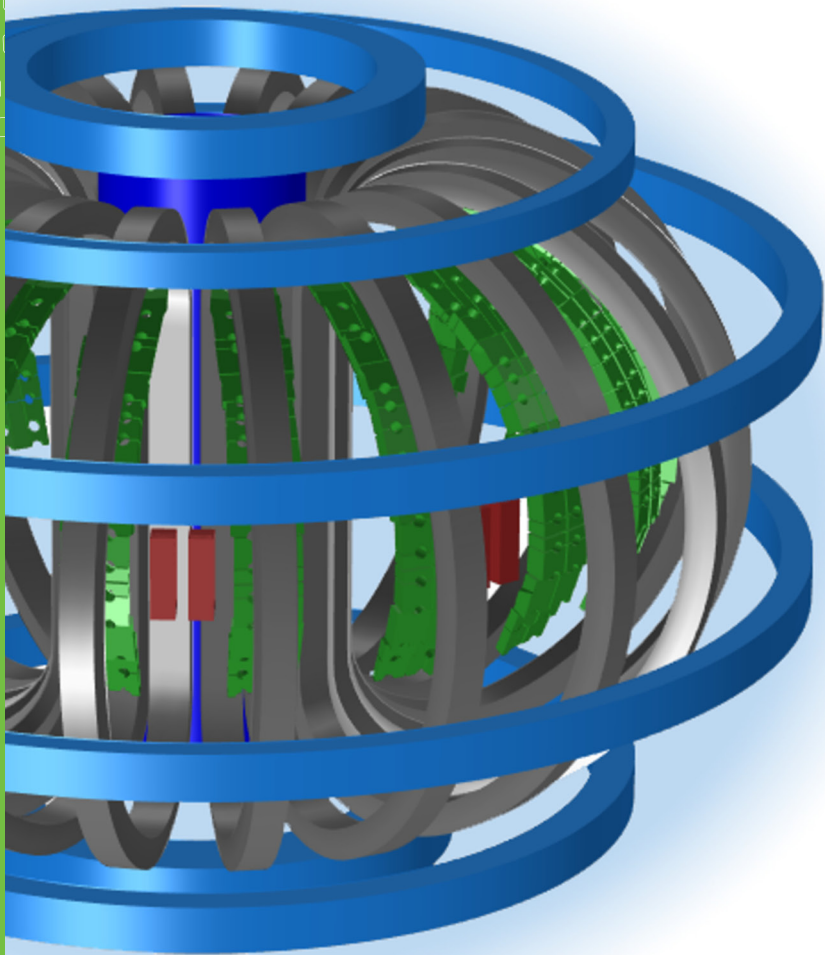

FinnFusion Yearbook 2015

Markus Airila (Ed.)



FinnFusion Yearbook 2015

Markus Airila (Ed.)

VTT Technical Research Centre of Finland Ltd

This work has been carried out within the framework of the EUROfusion Consortium and has received funding from the Euratom research and training programme 2014-2018 under grant agreement No 633053. The views and opinions expressed herein do not necessarily reflect those of the European Commission.



ISBN 978-951-38-8431-4 (Soft back ed.)

ISBN 978-951-38-8432-1 (URL: <http://www.vttresearch.com/impact/publications>)

VTT Science 129

ISSN-L 2242-119X

ISSN 2242-119X (Print)

ISSN 2242-1203 (Online)

<http://urn.fi/URN:ISBN:978-951-38-8432-1>

Copyright © VTT 2016

JULKAISIJA – UTGIVARE – PUBLISHER

Teknologian tutkimuskeskus VTT Oy

PL 1000 (Tekniikantie 4 A, Espoo)

02044 VTT

Puh. 020 722 111, faksi 020 722 7001

Teknologiska forskningscentralen VTT Ab

PB 1000 (Teknikvägen 4 A, Esbo)

FI-02044 VTT

Tfn +358 20 722 111, telefax +358 20 722 7001

VTT Technical Research Centre of Finland Ltd

P.O. Box 1000 (Tekniikantie 4 A, Espoo)

FI-02044 VTT, Finland

Tel. +358 20 722 111, fax +358 20 722 7001

Cover image: Seppo Sipilä

Juvenes Print, Tampere 2016

Preface



The most significant occasion in the European fusion research field in 2015 was without any doubt the start of operation of Wendelstein 7-X (W7-X) stellarator in Greifswald, Germany. This is the first major European plasma device built for a long time. W7-X, the world's largest stellarator, successfully completed its first plasma discharge on 10 December 2015. W7-X will be the key to investigating a stellarator's suitability as possible design for a future fusion power plant, and this has put the device firmly in the EUROfusion

Roadmap to the realisation of fusion energy. The 16-m-wide W7-X, dubbed as the dark horse of fusion, is expected to test whether the plasma equilibrium and confinement will be of a quality comparable to that of a tokamak of the same size. The results from experiments at W7-X are eagerly awaited by the fusion community because it might well change the outlook for fusion power. Hundreds of fusion scientists worldwide were witnessing the first plasma discharge with remote video and audio connections to the control room of W7-X, including a large group in Finland as well.

Major changes took also place in both leadership of ITER and F4E. The ITER Council appointed Bernard Bigot, from France, as the Director-General of the ITER Organization. He is the first European ITER director, following the two Japanese predecessors. Bernard Bigot has been closely associated with ITER since France's bid to host the project in 2003. Construction is now proceeding at full speed. Concrete has been recently poured for the first level of the Tokamak bioshield. Buildings, systems, and structures are emerging. Manufacturing is underway at dozens of ITER Member locations worldwide. The first components have been installed. Most major manufacturing contracts have been signed. In Barcelona, the F4E Governing Board has appointed Johannes Schwemmer as the Executive Director of Fusion for Energy. Johannes Schwemmer has been working in the fields of information, telecommunications and business technology for more than 25 years. He has a proven track record in international collaboration, project management and business strategy. He is the first F4E director coming from a field outside fusion.

The European fusion research showed the first smooth year in 2015, with well-established and operational EUROfusion Consortium workprogramme and policies,

to implement the “Roadmap to the realisation of fusion energy to the grid by 2050”. In practice, the Commission has now outsourced most of its past functions to EUROfusion. The work in EUROfusion Consortium is organised in some 20 work packages covering all the area of expertise needed to build a fusion power plant. Our Finnish research unit is involved in about half of them, thus showing a clear focus only on those areas being either strategically or nationally important to us or where Finnish expertise is needed by EUROfusion.

Fortum was accepted by the European Commission as the first Finnish industry linked third party to the EUROfusion grant. Simultaneously, Fortum was accepted as a new research unit in the FinnFusion Consortium. Involving more Finnish industry in fusion research is very much welcomed. Therefore, the main theme in the FinnFusion annual seminar was “Industry Involvement in ITER and Fusion Research: Finnish Success Stories”. Industry was very well presented in the seminar that was hosted by VTT in Tampere. In addition, all the FinnFusion students and fellows (13 students funded by EUROfusion) presented their work in one separate session.

In 2015, the FinnFusion Consortium participated in several EUROfusion work packages. The largest ones were JET experimental campaigns, JET fusion technology, materials’ research, plasma facing components, remote maintenance and medium size tokamak work packages. As the new topic, DEMO integration work on plant level system engineering, design integration and physics integration using Apros code package was taken on board. Selected highlights of these activities are reported briefly in Chapters 2 and 3.

The F4E activities of FinnFusion continued seamlessly from previous years. Aalto University completed 3D modelling of magnetic fields and related fast particle losses grant, demonstrating that escaping energetic particles will not pose a threat to the first wall of ITER. As far as remote handling is concerned, year 2015 saw continuation for successful demonstrations of divertor handling operations at the DTP2 facility. As a result of the long-term extensive research & development experience of the ITER Divertor Remote Handling systems and equipment, VTT is now a partner also in the consortium that supplies the neutral beam remote handling system for ITER.

It is pleasure to state that the share of the Finnish contribution and overall EU-level funding is on the same level as in 2014, i.e. significantly higher than during the association era in FP7. The challenge is to exploit these international networks and expertise to national benefits and further, to find national funding to complement the EU funded projects. As a consequence, a strategic white paper on Finnish fusion strategy 2015–2025 was prepared and handed over to ministry (MEE), Tekes and Academy of Finland. Let’s all hope that this helps us to keep and further strengthen the position of FinnFusion in both the EUROfusion Consortium as well as in F4E and ITER.



Tuomas Tala
Head of Research Unit
FinnFusion Consortium

Contents

Preface	3
List of acronyms and names	7
1. FinnFusion Organization	11
1.1 Programme Objectives.....	11
1.2 EUROFUSION and FinnFusion Consortia	11
1.3 Research Unit.....	12
1.4 FinnFusion Advisory Board	14
1.5 Finnish Members in the European Fusion Committees.....	15
2. ITER Physics Workprogramme 2015	17
2.1 WP JET1: JET experimental campaigns C35–36.....	17
2.2 WP JET2: Plasma-facing components.....	18
2.3 WP JET4: Enhancements	20
2.4 WP MST1: Medium-size tokamak campaigns	20
2.5 WP PFC: Preparation of efficient PFC operation for ITER and DEMO.....	22
2.6 WP DTT1: Assessment of altern. div. geometries and liquid metal PFCs ..	24
2.7 WP CD: Code development for integrated modelling.....	25
3. Power Plant Physics & Technology Work Programme 2015	27
3.1 WP PMI: Plant level system engineering, design integration and physics integration	27
3.2 WP BOP: Heat transfer, balance-of-plant and site.....	28
3.3 WP RM: Remote maintenance systems.....	30
3.4 WP MAT: Materials.....	31
3.5 WP ENS: Early Neutron Source definition and design	32
4. Public Information	34
5. Education and Training	36
5.1 WP EDU – FinnFusion student projects.....	36
5.2 WP TRA – EUROfusion Researcher Grant	44
5.3 WP TRA – EUROfusion Researcher Grant	45
5.4 WP TRA – EUROfusion Engineering Grant.....	46

6. Enabling Research	48
7. NJOC and PMU	49
7.1 Overview	49
7.2 EUROfusion PMU WP JET1 Responsible Officer.....	49
8. International collaborations	50
8.1 DIII-D tokamak	50
8.2 Ioffe Institute.....	51
9. Full-f gyrokinetic turbulence code ELMFIRE	52
10. Fusion for Energy activities	54
10.1 Effect of the European design of TBMs on fast ion power loads in ITER ...	54
10.2 System level design for the Remote Handling Connector and ancillary components.....	55
10.3 Optimisation of the Divertor Central Cassette maintenance operation.....	56
11. Other activities	58
11.1 Missions and secondments	58
11.2 Conferences, seminars, workshops and meetings.....	61
11.3 Other visits	63
11.4 Visitors	63
11.5 Publications.....	65

Abstract

Tiivistelmä

List of acronyms and names

AFSI	AFSI Fusion Source Integrator
AHP	Analytic hierarchy process
ASCOT	Accelerated Simulation of Charged Particle Orbits in Tori (particle tracing code)
AU	Aalto University, Espoo/Helsinki, Finland
AUG	ASDEX Upgrade (tokamak facility)
AWP	Annual Work Programme (of EUROfusion)
BB	(Tritium) Breeding blanket
BBNBI	Beamlet-based neutral beam injection (simulation code)
CAD	Computer-aided design
CC	(Divertor) Central cassette
CCFE	Culham Centre for Fusion Energy
CCOR	(Divertor) Central cassette outer rails
CEA	Commissariat à l'Énergie Atomique et aux Énergies Alternatives (French Research Unit)
CFC	Carbon fibre composite
CPT	Core Programming Team under EUROfusion WP CD
COMSOL	Multiphysics software platform
CSC	(Finnish) IT Center for Science
CU	Comenius University (Slovakian Research Unit)
DIII-D	Tokamak facility at General Atomics, San Diego
DE	Differential evolution (optimization method)
DEMO	Future demonstration fusion power plant
DIFFER	Dutch Institute for Fundamental Energy Research (Dutch Research Unit)
DIV	Divertor
DOF	Degree of freedom

DONES	DEMO oriented neutron source
DRHS	Divertor remote handling system
DTP2	Divertor test platform phase 2 (test facility in Tampere)
EAMA	Articulated serial manipulator on EAST tokamak
EAST	Experimental Advanced Superconducting Tokamak
ECC	ELM control coil
EDGE2D	Fluid plasma simulation code
EDP	Erosion-deposition probe
EIRENE	Neutral particle simulation code
ELM	Edge localised mode (plasma instability)
ELMFIRE	Gyrokinetic particle-in-cell simulation code
ENEA	Ente per le Nuove tecnologie, l'Energia e l'Ambiente (Italian Research Unit)
EPFL	École polytechnique fédérale de Lausanne
ERO	Monte Carlo impurity transport simulation code
ETS	European transport solver (simulation code)
EU-IM	European Integrated Modelling approach (former ITM Task Force)
EUROfusion	European consortium implementing the Fusion Roadmap
F4E	Fusion for Energy (the European Domestic Agency of ITER)
FEM	Finite element method (numerical method)
FI	Ferritic insert
FPA	Framework project agreement
FT-2	Tokamak facility
GAM	Geodesic acoustic mode (plasma instability)
GENE	Gyrokinetic particle-in-cell simulation code
GLADIS	Garching Large Divertor Sample test facility
GYSELA	Gyrokinetic particle-in-cell simulation code
HCD	Heating and current drive
HFCG	High-field gap closure tile (plasma-facing component at JET)
IAEA	International Atomic Energy Agency
ICRH	Ion cyclotron resonance heating
IFERC	International Fusion Energy Research Centre
IFMIF	International Materials Irradiation Facility (under design)
ILW	ITER-like wall
IPP	Institut für Plasmaphysik, Garching/Greifswald

IPP.CR	Institute of Plasma Physics of the Czech Academy of Sciences (Czech Research Unit)
IST	Instituto Superior Técnico (Portuguese Research Unit)
ITER	Next step international tokamak experiment under construction in Cadarache, France (“the way” in Latin)
ITM	Integrated Tokamak Modelling (predecessor of WP CD)
ITPA	International Tokamak Physics Activity
JET	Joint European Torus (tokamak facility)
KIT	Karlsruhe Institute of Technology
LIBS	Laser induced breakdown spectroscopy
LFS	Low-field (outer) side of tokamak
LLNL	Lawrence Livermore National Laboratory
LUT	Lappeenranta University of Technology
MCMC	Markov chain Monte Carlo (optimization method)
MD	Molecular dynamics (simulation method)
MEE	Ministry of Employment and the Economy (in Finland)
MHD	Magnetohydrodynamics
MMS	Multi-module blanket segments
MPI	Message passing interface (application programming interface for parallel computing)
NBI	Neutral beam injection
NEMORB	Gyrokinetic particle-in-cell simulation code
NJOC	New JET Operating Contract
NPA	Neutral particle analyser
NRA	Nuclear reaction analysis
OKMC	Object Kinetic Monte Carlo (material simulation method)
OpenMP	Open multi-processing (application programming interface for parallel computing)
OROCOS	Standard open robotic platform
OSM	Onion-skin model (for plasma simulation)
PFC	Plasma-facing component
PHTS	Primary heat transfer system
PIC	Particle-in-cell (plasma simulation method)
PMU	Programme Management Unit (of EUROfusion; Garching, Culham)
PPPL	Princeton Plasma Physics Laboratory
PSO	Particle swarm optimization (optimization method)
RAMI	Reliability, availability, maintainability and inspectability

RBS	Rutherford backscattering spectroscopy
RH	Remote handling
RHC	Remote handling connector
SE	Systems engineering
SIMS	Secondary ion mass spectrometry
SOL	Scrape-off layer
SOLPS	Scrape-off Layer Plasma Simulation (fluid plasma simulation code)
TBM	Tritium breeding module, Test blanket module (in the case of ITER)
TCV	Tokamak à Configuration Variable (tokamak facility)
TDS	Thermal desorption spectrometry
Tekes	The Finnish Funding Agency for Innovation
UH	University of Helsinki
TUT	Tampere University of Technology
VTT	VTT Technical Research Centre of Finland Ltd
VV	Vacuum vessel
ÅA	Åbo Akademi University, Turku, Finland

1. FinnFusion Organization

1.1 Programme Objectives

The Finnish Fusion Programme, under the FinnFusion Consortium, is fully integrated into the European Programme, which has set the long-term aim of the joint creation of prototype reactors for power stations to meet the needs of society – operational safety, environmental compatibility and economic viability. The objectives of the Finnish programme are:

- Develop fusion technology for ITER in collaboration with Finnish industry
- Provide a high-level scientific contribution to the accompanying Euratom Fusion Programme under the EUROfusion Consortium.

This can be achieved by close collaboration between the Research Units and industry, and by strong focusing the R&D effort on a few competitive areas. Active participation in the EUROfusion Work Programme and accomplishing ITER technology development Grants by F4E provide challenging opportunities for top level science and technology R&D work in research institutes and Finnish industry.

1.2 EUROFUSION and FinnFusion Consortia

During the Horizon 2020 framework, the Euratom Fusion Research program is organised under the EUROfusion Consortium with 29 beneficiaries, practically one per member state. IPP from Germany acts as the co-ordinator of the Consortium. VTT acts as the beneficiary to EUROfusion in Finland. EUROfusion Consortium implements the activities described in the Roadmap to Fusion during Horizon 2020 through a Joint programme of the members of the EUROfusion consortium. A 734 M€ grant (including NJOC) for the period 2014–2018 forms the basis of Euratom Fusion Research program and its funding.

In order to govern the fusion research activities in Finland, FinnFusion Consortium was established and the consortium agreement signed among the participating research units in November 2014. The role of Tekes changed from being the signing body of the Association to act as the national funding body of the Finnish fusion research projects. Towards the European Commission and the EUROfusion Consortium, Tekes plays the role of the program owner. Now within the EUROfu-

sion Consortium, VTT is the beneficiary and therefore plays the role of the program manager towards the Commission. The universities carrying out fusion research in Finland are acting as linked third parties to the Consortium. The FinnFusion organigram is presented in Figure 1.1.

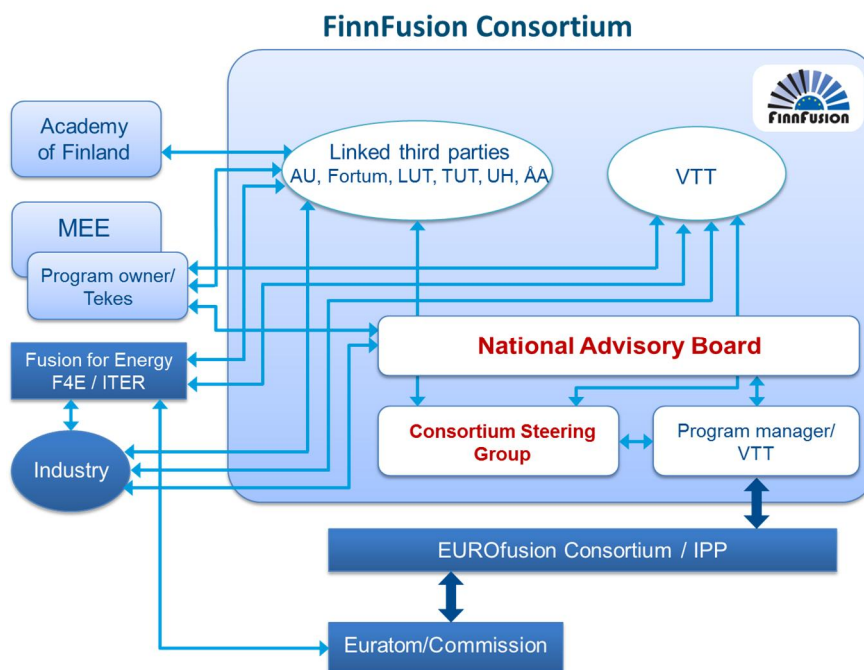

Figure 1.1. Organigram of Finnish Fusion Research Community in 2015–2020.

1.3 Research Unit

The Finnish Research Unit, FinnFusion, consists of several research groups from VTT, universities and industry. The Head of the Research Unit is Dr. Tuomas Tala from VTT. The following institutes and universities participated in the fusion research during 2015:

VTT Tech. Research Centre of Finland – Smart industry and energy systems

Activities: Co-ordination, tokamak physics and engineering

Members: Dr. Tuomas Tala (Head of Research Unit), Dr. Leena Aho-Mantila, Dr. Markus Airila, Dr. Antti Hakola, MSc. Atte Helminen, MSc. Ilkka Karanta, Mrs. Anne Kemppainen (administration), MSc. Seppo Koivuranta, Dr. Jari Likonen (Project Manager), MSc. Sixten Norrman, Dr. Antti Salmi, MSc. Paula Sirén, MSc. Tero Tyrväinen

Activities: Remote handling, DTP2
Members: Dr. Timo Määttä, MSc. Jorma Järvenpää, MSc. Harri Mäkinen, Lic.Tech. Mikko Siuko, MSc. Hannu Saarinen, MSc. Karoliina Salminen, MSc. Romain Sibois, MSc. Risto Tuominen, Tech. Vesa Hämäläinen

Aalto University, School for Science (AU), Department of Applied Physics

Activities: Physics
Members: Prof. Mathias Groth (Head of Laboratory), Dr. Otto Asunta, Dr. Aaro Järvinen, MSc. Juuso Karhunen, Dr. Timo Kiviniemi, MSc. Tuomas Korpilo, Dr. Tuomas Koskela (NJOC secondee), Dr. Taina Kurki-Suonio, Dr. Susan Leerink, Dr. Johnny Lönnroth (PMU secondee), MSc. Toni Makkonen, Dr. Juho Miettunen, Dr. David Moulton, MSc. Paavo Niskala, MSc. Ivan Paradela Perez, Dr. Ronan Rochford, Dr. Marko Santala (NJOC secondee), Dr. Seppo Sipilä, Dr. Antti Snicker, MSc. Jaroslavs Uljanovs, MSc. Simppa Äkäslompolo
Students: Mathias Fontell, Petteri Heliste, Andreas Holm, Mikko Karjalainen, Joona Kontula, Sanna-Paula Pehkonen, Heikki Sillanpää, Konsta Särkimäki, Juuso Terävä, Antti Ukkonen, Jari Varje

University of Helsinki (UH), Accelerator Laboratory

Activities: Physics, materials
Members: Dr. Tommy Ahlgren, Dr. Carolina Björkas, MSc. Laura Bukonte, Dr. Flyura Djurabekova, MSc. Fredric Granberg, Dr. Kalle Heinola (NJOC secondee), Dr. Krister Henriksson, Dr. Ville Jansson, Dr. Pekko Kuopanportti, MSc. Aki Lahtinen, Dr. Benoît Marchand, Dr. Kenichiro Mizohata, MSc. Morten Nagel, Prof. Kai Nordlund (Project Manager), Dr. Jussi Polvi, Prof. Jyrki Räisänen (Project Manager), MSc. Elnaz Safi, MSc. Andrea Sand, Dr. Vladimir Tuboltsev, Dr. Mohammad Wali Ullah
Students: Miika Haataja, Riikka Ruuth

Tampere University of Technology (TUT), Inst. of Hydraulics and Automation

Activities: Remote handling, DTP2
Members: MSc. Liisa Aha, MSc. Dario Carfora, Dr. Juha-Pekka Karjalainen, MSc. Janne Koivumäki, MSc. Ville Lyytikäinen, Prof. Jouni Mattila (Project Manager), MSc. Jyrki Tammisto, MSc. Janne Tuominen, MSc. Jukka Väyrynen

Lappeenranta University of Technology (LUT), Lab. of Intelligent Machines

Activities: Robotics
Members: Prof. Heikki Handroos (Project Manager), MSc. Ming Li, DSc. Yongbo Wang, Prof. Huapeng Wu, MSc. Jing Wu

1.4 FinnFusion Advisory Board

FinnFusion Advisory Board gives opinions on the strategy and planning of the national research effort, promotes collaboration and information exchange between research laboratories and industry and sets priorities for the Finnish activities in the EU Fusion Programme. The Board consists of the Parties and other important Finnish actors in Finnish fusion energy research.

Chairman	Janne Ignatius, CSC
Members	Henrik Immonen, Abilitas
	Arto Timperi, Comatec
	Jukka Kolehmainen, Diarc
	Leena Jylhä, Finnuclear
	Kristiina Söderholm, Fortum
	Mika Korhonen, Hollming Works
	Olli Pohls, Hytar
	Ben Karlemo, Luvata
	Jarmo Lehtonen, Metso Minerals
	Vesa Kyllönen, National Instruments Finland
	Pertti Pale, PPF Consulting
	Antti Väihkönen, Academy of Finland
	Janne Uotila, Sandvik
	Veera Sylvius, Space Systems Finland
	Juha Linden, Tekes
	Hannu Juuso, Tekes
	Timo Laurila, Tekes
	Arto Kotipelto, Tekes
	Kari Koskela, Tekes
	Herkko Plit, MEE
	Liisa Heikinheimo, TVO
	Timo Vanttola, VTT
	Riikka Virkkunen, VTT
	Timo Määttä, VTT
	Mathias Groth, Aalto
	Kai Nordlund, UH
	Jouni Mattila, TUT
	Heikki Handroos, LUT
	Jan Westerholm, ÅA
Co-ordinator	Tuomas Tala, VTT
Secretary	Markus Airila, VTT

The FinnFusion advisory board had two meetings in 2015.

1.5 Finnish Members in the European Fusion Committees

1.5.1 Euratom Science and Technology Committee (STC)

- Rainer Salomaa, Aalto University

1.5.2 Euratom Programme Committee, Fusion configuration

- Tuomas Tala, VTT
- Arto Kotipelto, Tekes

1.5.3 EUROfusion General Assembly

- Tuomas Tala, VTT

1.5.4 EUROfusion Science and Technology Advisory Committee (STAC)

- Kai Nordlund, UH
- Mikko Siuko, VTT

1.5.5 EUROfusion Project Boards

- WP JET2: Antti Hakola, VTT
- WP JET4: Marko Santala, AU
- WP PFC: Jari Likonen, VTT
- WP DTT1: Leena Aho-Mantila, VTT
- WP CD: Timo Kiviniemi, AU
- WP S1 & S2: Taina Kurki-Suonio, AU
- WP BB & BOP: Markus Airila, VTT
- WP RM: Timo Määttä, VTT
- WP MAT: Kai Nordlund, UH
- WP ENS: Mikko Siuko, VTT

1.5.6 Governing Board for the Joint European Undertaking for ITER and the Development of Fusion Energy, “Fusion for Energy” (F4E GB)

- Kari Koskela, Tekes
- Tuomas Tala, VTT

1.5.7 Procurements and Contracts Committee for the Joint European Undertaking for ITER and the Development of Fusion Energy, “Fusion for Energy” (F4E PCC)

- Herkko Plit, Ministry of Employment and the Economy

1.5.8 Other international duties and Finnish representatives in the following fusion committees and expert groups in 2014

- Markus Airila is the VTT representative in EUROfusion Communications Network (FuseCOM).
- Kalle Heinola is a member of the international committee of the H-Workshop (International Workshop on Hydrogen Isotopes in Fusion Reactor Materials).
- Hannu Juuso is an Industry Liaison Officer (ILO) for F4E, Timo Määttä is the European Fusion Laboratory Liaison Officer (EFLO) and Pertti Pale is a consultant for Fusion-Industry matters.
- Taina Kurki-Suonio is a member of the ITPA expert group on energetic particles. Tuomas Tala is a member of the ITPA expert group on transport and confinement.
- Taina Kurki-Suonio is appointed as an affiliated professor in physics, in particular plasma physics (2014–2016) at Chalmers University of Technology, Gothenburg, Sweden.
- Taina Kurki-Suonio is a member of the *Nuclear Fusion* Editorial Board
- Kai Nordlund is a member of the international committee of the COSIRES Conference (Computer Simulation of Radiation Effects in Solids).
- Harri Tuomisto is a member of the Fusion Industry Innovation Forum Management Board (FIIF MB).
- Harri Tuomisto is a member of the DEMO stakeholders group.

2. ITER Physics Workprogramme 2015

2.1 WP JET1: JET experimental campaigns C35–36

Research scientists: M. Groth, A. Järvinen, T. Koskela, S. Leerink, D. Moulton,
M. Santala, J. Uljanovs, AU
K. Heinola, UH
M. Airila, J. Likonen, S.-P. Pehkonen, A. Salmi, P. Sirén, T. Tala,
VTT

2.1.1 Overview

Analysis of JET C31–34 experiments continued in 2015 and campaign C35 started late in the year. FinnFusion contributed mainly to investigations of seeded and intrinsic impurities in the SOL, core transport studies, and support for JET neutral particle analysers. In this Yearbook we highlight the study of radiative divertor studies in JET H-mode plasmas, carried out over several years.

2.1.2 Radiative divertor studies in JET high confinement mode plasmas

Radiative divertor operation was examined experimentally and with EDGE2D-EIRENE simulations in JET high-triangularity H-mode plasmas with N₂ and Ne injection. These studies show that the heat flux to the low-field side target plates was reduced by factors of 5–10 with both impurity species. The simulations predict that nitrogen radiates predominantly in the divertor, and partial detachment at the low field side plate achieved with dominant divertor radiation. In contrast, neon radiation is dominated by regions outside the divertor; in these plasmas at pedestal temperatures 600–700 eV. Hence, with neon, partial detachment was achieved by reduction of the power flow across the separatrix in addition to radiation in the divertor. The EDGE2D-EIRENE simulations capture the measured reduction of the ion current to the low field side plate only, when the radiation through nitrogen or neon is imposed. The simulations underestimate radiation by deuterium emission, which remained an open issue in these and other studies. These studies were presented as an oral contribution at the 2015 APS conference in Savannah, Georgia, USA.

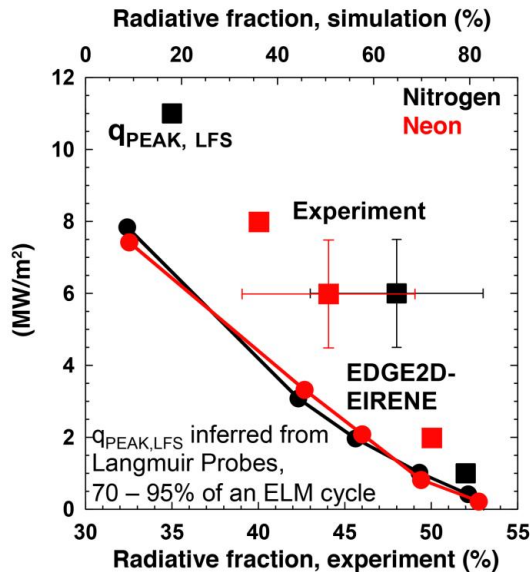

Figure 2.1. Measurements and EDGE2D-EIRENE predictions of the power density to the JET low field side divertor as a function of radiative fraction in nitrogen and neon-seeded H-mode discharges.

Comparison of semi-horizontal and fully vertical divertor plasma configurations in unseeded and nitrogen-seeded, ELMy H-mode plasma in JET showed little to no differences in the reduction of the peak power to the low field side plate with increasing radiation power in the divertor. Little to no benefit in operating in a vertical configuration was observed for minimizing the effective charge state (impurity density) of the plasma. A significant change in the pedestal ionization sources in vertical over horizontal configurations is predicted by EDGE2D-EIRENE. This work was presented as an oral contribution at the 21st ITPA DSOL meeting in Princeton, New Jersey, USA, and will be submitted to PPCF in 2016.

2.2 WP JET2: Plasma-facing components

Research scientists: K. Heinola, A. Lahtinen, K. Mizohata, J. Räsänen, UH
M. Airila, A. Hakola, S. Koivuranta, J. Likonen, VTT

During the shutdown in 2009–2011 all the carbon-based plasma facing components (PFC) were replaced with the ITER-like wall (JET-ILW). Second set of wall and divertor tiles for post-mortem analyses were removed during the shutdown in 2014. The divertor tiles of JET-ILW are made of tungsten-coated carbon fibre composites (CFC), except the load bearing tiles in the outer divertor which are made of solid tungsten. Limiters in the main chamber are manufactured from solid beryllium.

The JET2 programme focused on post-mortem analysis of wall components and in-vessel erosion-deposition probes (EDP) in 2015 and VTT used Secondary Ion Mass Spectrometry (SIMS), Thermal Desorption Spectrometry (TDS) and tile profiling for the analysis of wall components. The latter two techniques are available at CCFE. Samples from inner divertor tiles high field gap closure (HFGC) and 1 exposed both in 2010–2014 and 2012–2014 were analysed with SIMS for erosion, deposition and fuel retention. Other tiles will be analysed in 2016. The highest deuterium amount is on top of tile 1 and HFGC tile. Deuterium amount on tile 1 is comparable to that for tile 1 exposed in 2010–2012. SIMS results for deuterium retention on other divertor tiles will be compared with TDS and Ion Beam Analysis (IBA) in 2016.

Fuel retention, especially the radioactive tritium (T), in the plasma-facing components plays an important role in the safe operation of future fusion devices such as ITER and DEMO. In ITER, the baseline strategy for the removal of retained T is baking of the main wall at 240°C and at 350°C for the divertor. In order to assess the efficiency of baking for T removal, hydrogen retention/release behaviour has been studied using realistic, ITER-Like tokamak samples exposed in 2010–2012 that were annealed by TDS. The TDS results showed that fuel release peaks were observed at temperatures above the baking temperatures which may have a significant impact on the planned ITER T-recovery strategy.

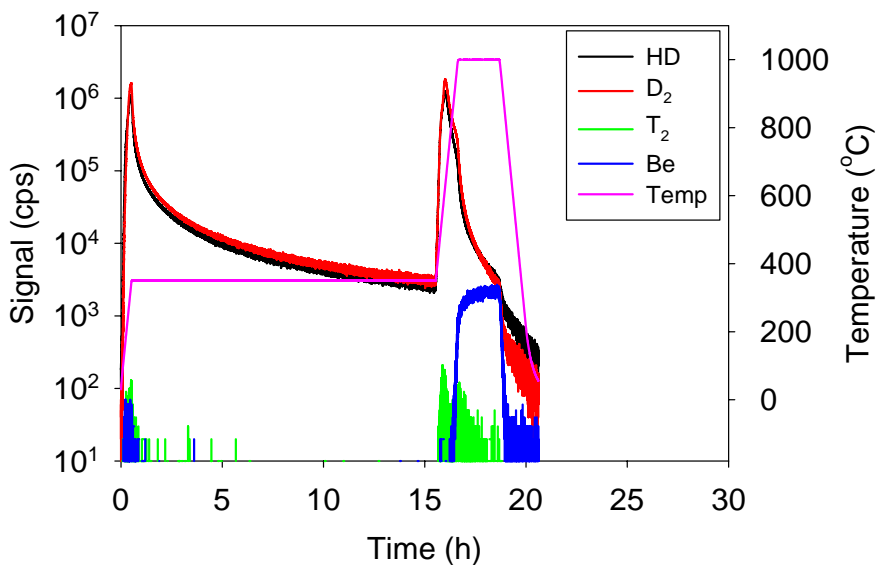

Figure 2.2. TDS spectrum for divertor tile 1 exposed in 2011–2012.

2.3 WP JET4: Enhancements

Research scientists: M. Santala, AU

WP JET4 work package consists of a number diagnostic enhancement projects. Several of them were launched under EFDA, with some EUROfusion elements added and some of them are pure EUROfusion projects. The FinnFusion-led project in WP JET4 is ISU2 (Isotope Separator Upgrade 2) to upgrade JET low energy neutral particle analyser (NPA) with custom silicon detectors and new data acquisition hardware and software. This project was initiated as an EFDA project but it also has a large EUROfusion component. ISU2 is carried out in collaboration with FinnFusion, VR (Sweden) and JET operator.

2.4 WP MST1: Medium-size tokamak campaigns

Research scientists: T. Kurki-Suonio, AU
A. Hakola, A. Salmi, T. Tala, VTT
A. Lahtinen, UH

2.4.1 Deputy Task Force Leadership activities

The main highlight for VTT in 2015 was the appointment of Antti Hakola as one of the Deputy Task Force Leaders of the MST1 work package. This took place in October, and the last couple of months of 2015 Hakola spent mainly in Garching and Lausanne to co-ordinate specific experiments at the ASDEX Upgrade (AUG) and TCV tokamaks. The responsibility areas of Hakola include the following headlines from the EUROfusion Roadmap: HL1.5 (Control of core contamination and dilution from W PFCs), HL1.6 (Determine optimum particle throughput for reactor scenarios), and HL2.2 (Prepare efficient PFC operation for ITER and DEMO). By the end of 2015, altogether 11 experiments were either started or completed under these headlines. They addressed, e.g., mitigating W accumulation in the core plasma, understanding filamentary transport in the scrape-off layer (SOL) plasma, measuring particle throughput by varying the pumping speed of the tokamak vessel, determining migration of nitrogen in the edge plasma, and investigating interaction of W plasma-facing components with helium plasmas. The results were presented in different review meetings and a number of conference contributions were submitted. In addition to these activities, Hakola took part in formulating a new procedure for calls for participation in future MST1 campaigns and for the structure of the entire Task Force together with other Task Force Leaders.

2.4.2 Plasma-wall interaction studies in AUG during helium plasmas

The second main research topic in 2015 was studying interaction of tungsten plasma-facing components (PFCs) with helium in AUG. This is motivated by the

possible start-up phase of ITER with helium plasmas, setting the need to understand the interaction process in detail. Specifically, the erosion, re-deposition, and retention characteristics of W PFCs need to be clarified. In addition, the possible modification of W surfaces during their exposure to helium plasmas is an important issue to be clarified: Helium can induce bubbles in W, which will lead to the formation of nanoscale structures in the material, even a porous surface layer with coral-like tendrils, referred to as fuzz.

The questions above were addressed during a dedicated experiment in December 2015. Here, the focus was on the possible formation of fuzz on virgin and pre-damaged W surfaces as well as erosion and re-deposition of W. Different W samples were exposed to 25 standard ELMy H-mode plasma discharges in He at the outer strike point of AUG. Four different types of samples, forming full poloidal rows across the strike-point region, were used: bulk pieces of W and Mo, thin (~30 nm) W marker coatings on graphite for determining net erosion/deposition of W, and samples pre-damaged by He exposure in the high heat-flux device GLADIS. The pre-damaged samples contained a variety of nanostructures on the surfaces, ranging from small He bubbles to fully formed W fuzz. The ion energy, surface temperature, and plasma fluence during the plasma experiment were all estimated to be above the limit for inducing further W surface modifications by helium. The D content of the plasma remained at a constant level of ~10% while the helium content was ~80% on average.

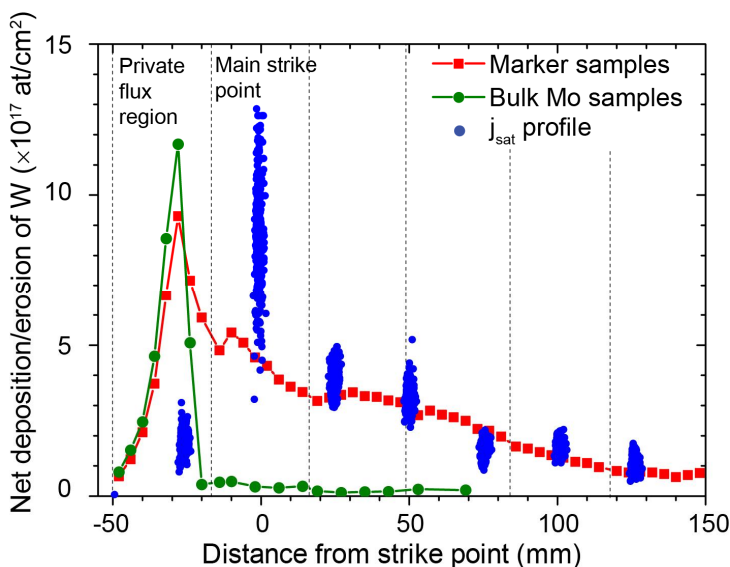

Figure 2.3. Net deposition/erosion of the W marker coating (red) and deposition of W on bulk Mo samples (green) after their exposure to ELMy H-mode plasmas in AUG. The poloidal profile for the ion saturation current, j_{sat} , is shown for the nominal position of the strike point; during the experiment, the strike point was varied within the range $-20\dots+30$ mm.

After the experiments, the samples were investigated by electron microscopy and different ion-beam analysis techniques. The results show that especially the pre-damaged samples had been covered with deposits, mainly containing W, C, O, B (from regular boronizations of the AUG vessel), and N and D from previous plasma operations. The coral-like surface structures were generally intact, with some erosion by sputtering visible in the main strike-point region, but no signs of melting. For the pre-damaged samples and the slightly rougher marker samples, noticeable deposition extended throughout the strike point region towards the main scrape-off layer. Only little erosion, if anything at all, could be seen for W and the entire outer strike-point region was a net deposition area – unlike the situation during D operations when large net erosion was measured around the strike point. This can be clearly seen in Figure 2.3 where the change in the thickness of the W marker as well as accumulation of W on the bulk Mo samples are shown. A strong influx of impurities and W from the main chamber is a potential contributor to the qualitatively different erosion/deposition profiles.

Based on these results, in tokamaks nanoscale modifications of different W surfaces compete with the surface being eroded by plasma and with the growth of co-deposited layers on PFCs by re-deposited W, seeded impurities, and eroded material from other regions of the torus upon exposure to He plasmas.

2.5 WP PFC: Preparation of efficient PFC operation for ITER and DEMO

Research scientists: M. Groth, P. Heliste, J. Karhunen, H. Sillanpää, AU
M. Airila, A. Hakola, VTT
C. Björkas, A. Lahtinen, K. Nordlund, J. Räisänen, E. Safi, UH

2.5.1 Modelling gross and net erosion of W in the outer strike-point region of ASDEX Upgrade

A large fraction of research efforts in 2015 was devoted to modelling the obtained gross and net erosion profiles of W, resulting from the exposure of W marker samples to low-density and high-temperature L-mode plasmas in AUG in 2014 and reported in the PFMC 2015 conference. The work is motivated by the need to properly understand and quantify erosion of the PFCs under different plasma scenarios and to distinguish between gross and net erosion since a large fraction of the primarily eroded W material will be promptly re-deposited.

In our experiment, special graphite probes, all equipped with a W marker and a shallow, uncoated trench magnetically downstream of the marker, were exposed at the outer strike-point region of AUG. The experiments indicate net erosion up to 0.15 nm/s close to the strike point and strong net deposition (~0.05–0.1 nm/s), poloidally on both sides of the strike point. The gross erosion, for its part, was 1.4–1.7 times larger than net erosion as estimated from the amount of W deposited at the bottom of the trench and from the measured emission of W I line at around

400.9 nm. This indicates re-deposition, particularly the prompt part of it, being only 30–40% of gross erosion, which is almost a factor of two smaller than what has previously been determined spectroscopically.

The erosion and deposition patterns were modelled by the Monte Carlo code ERO and compared with those provided by Particle-In-Cell (PIC) simulations at University of Marseille. The divertor version of ERO was used and the modelling was carried out in two simplified set-ups. First, the true geometry of the probes was implemented but constant values for the plasma parameters were used. The second step was to study poloidal transport of W using realistic profiles for the plasma parameters, obtained from OSM simulations and with the strike point values of $n_e = 2.0 \times 10^{19} \text{ m}^{-3}$ and $T_e = 20 \text{ eV}$.

We observed that erosion is dominated by impurities (B, C, and N in AUG) but the erosion/deposition rate is mainly determined by the effective charge, Z_{eff} , not by the actual impurity mix. The simulations can qualitatively explain the erosion dip around the strike point and the deposition peak above it as we notice from Figure 2.4 for an example case where $n_W = 0.005\%$, $n_C = 0.5\%$, $n_B = 0.5\%$, and $n_N = 0.5\%$ of n_e in the background plasma. The shape of the curve in Figure 2.4 is mainly determined by the poloidal profile of T_e while the effect of n_e on erosion/deposition behaviour was much more subtle. The W concentration of the background plasma had a relatively small, yet visible effect on the absolute values of the simulated net erosion/deposition when the concentration was kept at reasonable values of $n_W < 0.01\%$ of n_e .

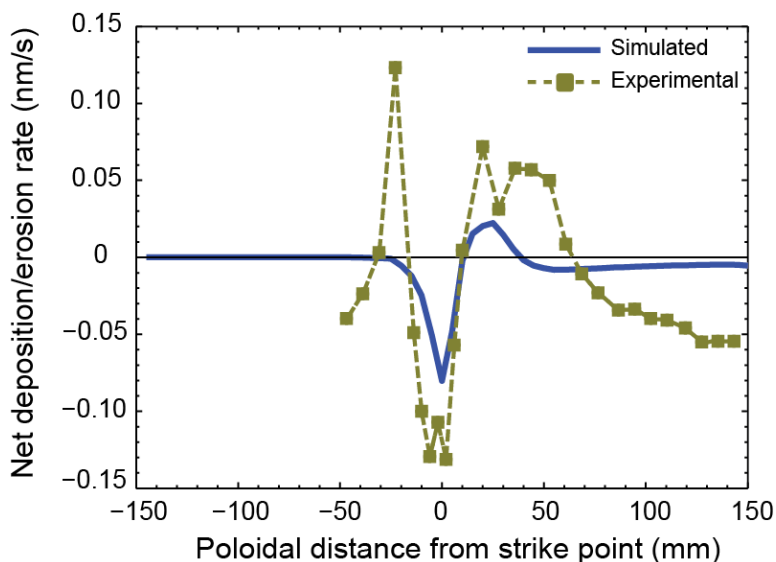

Figure 2.4. Example of simulated net erosion profiles of W (solid blue line) for the case with $n_W = 0.005\%$, $n_C = 0.5\%$, $n_B = 0.5\%$, and $n_N = 0.5\%$ of n_e . For comparison, also the experimentally determined net-erosion profile is shown in the figure.

The PIC simulations of the plasma sheath indicate that the erosion/deposition profiles of W are extremely sensitive to the poloidal profiles of the plasma parameters. By using background plasmas obtained from SOLPS simulations, the net deposition regions around the strike-point zone were noticed to emerge from strong local (prompt) re-deposition of W and sticking of W from the main plasma, with the latter corresponding to 10–20% of total re-deposition.

2.5.2 Molecular dynamics simulations of Be-D molecular erosion

Extensive experimental work on beryllium samples exposed to D plasmas can be found in literature. A broad database on Be erosion yields has been obtained but, unfortunately, the underlying erosion mechanisms as well as issues like the relationship of the surface temperature with the D concentration at the surface have not been fully explained or described.

However, accurate Be-D molecular erosion yields can be computed using a combined Molecular Dynamics and Object Kinetic Monte Carlo (MD-OKMC) multi-scale approach, allowing a more detailed description of the complex relationship, e.g., between the surface temperature and the D concentration. In our work, we first used the OKMC technique to determine equilibrium D profiles in Be by varying the vacancy concentration (0–20%) and surface temperature (300–800 K). Then, the D and vacancy profiles from OKMC were used to set-up Be substrates for the MD irradiation simulations that represent surface morphologies in long-term equilibrium. Be-D molecular erosion yields were studied by irradiating these cells with D, with energies at 10–200 eV, and also scanning over different surface temperatures (300–800 K).

Our OKMC results show that there is almost a linear dependence between the D concentration and the vacancy concentration while the surface temperature has a significant effect on the D depth profile. We have also shown the results for Be erosion from MD simulations in more controlled conditions. The benefits of a simple multi-scale scenario, including long-term effects and resulting in a more reliable erosion database will be highlighted in this work.

2.6 WP DTT1: Assessment of altern. div. geometries and liquid metal PFCs

Research scientist: L. Aho-Mantila, VTT

WP DTT1 comprises subprojects which are in support of alternative power exhaust solutions for DEMO and should provide the necessary information for the eventual preparation of the DTT. Specifically, the subprojects should explore the coil configurations for alternative divertor geometries, predict particle transport and power exhaust by modelling at different levels of sophistication and the exhaust capability of liquid PFC solutions. Before the conceptual design of a DTT can begin, integration issues and DEMO compatibility must be assessed within this

Work Package. As for WPPFC, liquid metal solutions should only be assessed if they do not rely on evaporation cooling and are compatible with low fuel retention. FinnFusion initiated SOLPS calculations for DEMO in 2015.

2.7 WP CD: Code development for integrated modelling

Research scientists: O. Asunta, S. Sipilä, S. Äkäslompolo, AU
M. Airila, VTT

The Monte Carlo beam ionization code BBNBI and the particle following code ASCOT have been included as actors in the Heating and Current Drive (HCD) workflow of the European Transport Solver (ETS) within the European Integrated Modelling (EU-IM) framework. In 2015, BBNBI and ASCOT as well as the AFSI Fusion Source Integrator (AFSI) have been maintained for compatibility with the latest releases of the data structure version 4.10b.

As the old ASCOT3 and ASCOT3.5 versions are being phased out, interfacing Thomas Jonsson's radiofrequency heating and current drive module RFOF with the current version 4 of ASCOT has been focused on in 2015. Testing and benchmarking of the ASCOT4/RFOF ion cyclotron heating and current drive simulation model against other codes will commence once the ASCOT4/RFOF actor is completed.

The 3D plasma-surface interaction and material migration code ERO was converted into a Kepler actor and first test runs attempted. The work required some re-structuring of the previously developed pre-and post-processors with the support from the CPT and an upgrade from dataversion 4.10a to 4.10b.

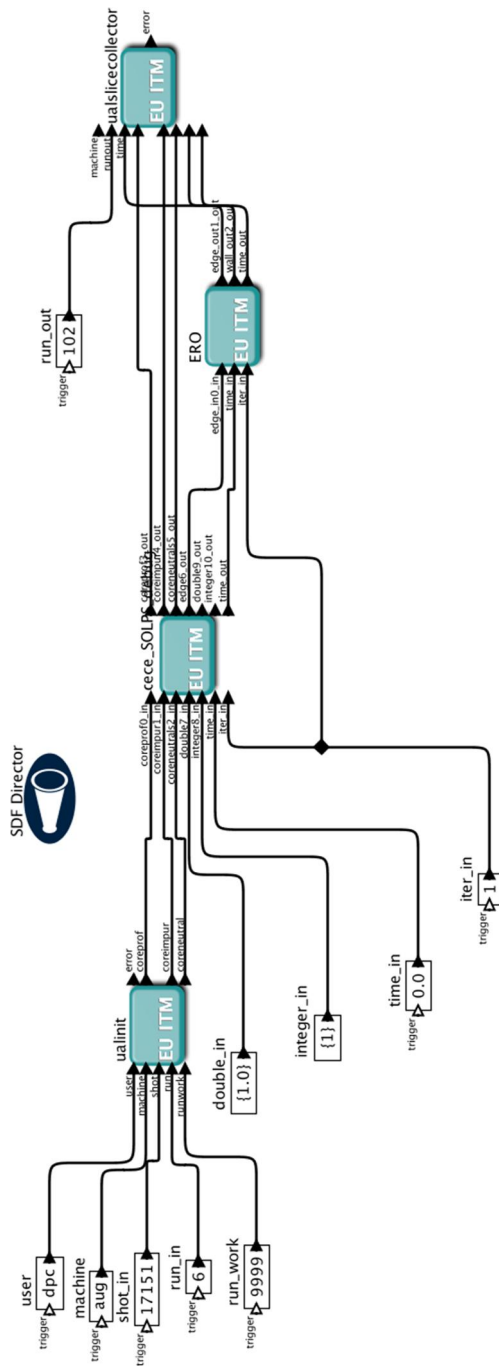

Figure 2.5. Prototype edge Kepler workflow involving SOLPS and ERO.

3. Power Plant Physics & Technology Work Programme 2015

3.1 WP PMI: Plant level system engineering, design integration and physics integration

Research scientists: A. Snicker, AU
S. Kiviluoto, Fortum
L. Aho-Mantila, S. Norrman, VTT

FinnFusion activities within WP PMI cover modelling tasks on fast ions, plasma power exhaust and power plant processes. In this Yearbook we report the progress of the task *Integrated system level simulation and analysis of DEMO with Apros*.

The DEMO power plant is designed to be the first fusion plant to produce electricity to the grid. In this task a model is developed for simulating the coupled behavior of thermal hydraulics, automation and electrical systems of the plant. The model is based on the results of Balance of Plant work package in which the plant is modelled with helium as the primary coolant. The WP BOP concentrates on the optimal process for electricity production, but WP PMI has a more comprehensive scope (see Figure 3.1 and Figure 3.2). Systems outside the heat transfer and power conversion will be included, such as the superconducting magnets that are essential for creating and controlling the plasma conditions for the fusion to occur. Various components within the process and general plant control strategies may also be studied in more detail.

The operation principle of DEMO is pulsed because fusion cannot be sustained continuously with the selected tokamak design. A dwell time is required every few hours. Therefore the impact of shorter dwell time on the parameters of the process components has been analyzed in WP PMI. Another future application for the WP PMI model is studying the effects of transients and assessing measures to assure process stability. This means e.g. maintaining the required cooling capacity for the breeding blankets, vacuum vessel and divertor and simultaneously preventing solidification of the molten salt in the intermediate energy storage circuit.

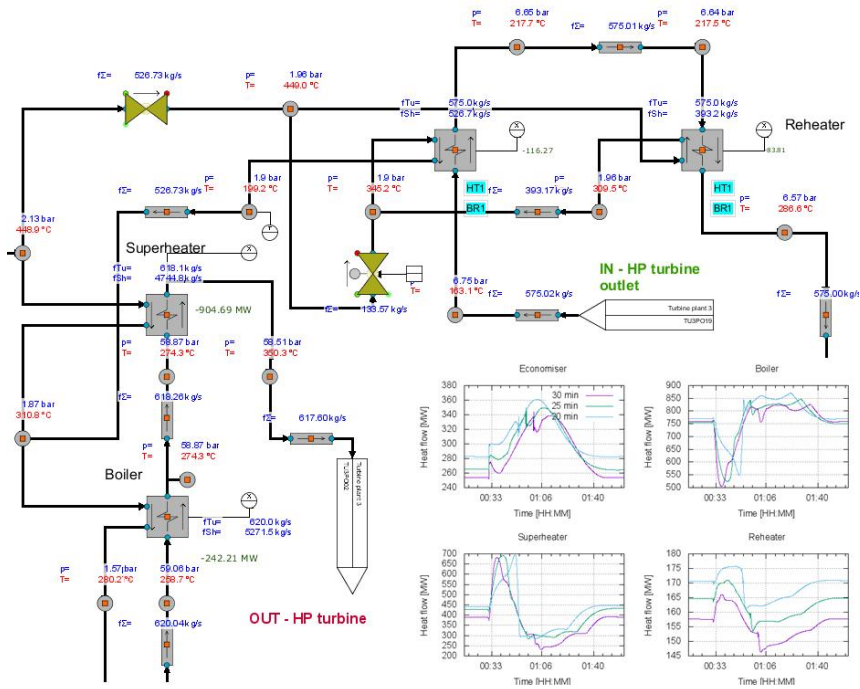

Figure 3.1. Molten salt heat exchangers in the Apros model and the effect of reduced dwell time on the heat transfer.

3.2 WP BOP: Heat transfer, balance-of-plant and site

Research scientists: S. Norrman, VTT

In WP BOP, FinnFusion focuses on the simulation of helium-cooled primary heat transfer system (PHTS) concept of DEMO with Apros. The development of the analysis model of the PHTS concept, shown in Figure 3.2, was continued. The purpose of the model is to provide a fully dynamic system-level simulation model to be used for performance assessment and studying of overall behaviour of the chosen technology with emphasis on optimal power production.

Revisions have been made to the model based on new reference data and assumptions on operation. Modifications include new source power levels of the breeding blanket (BB), divertor (DIV) and vacuum vessel (VV), and some changes related to process and automation system configurations. In the model development coordination with especially KIT has been emphasized.

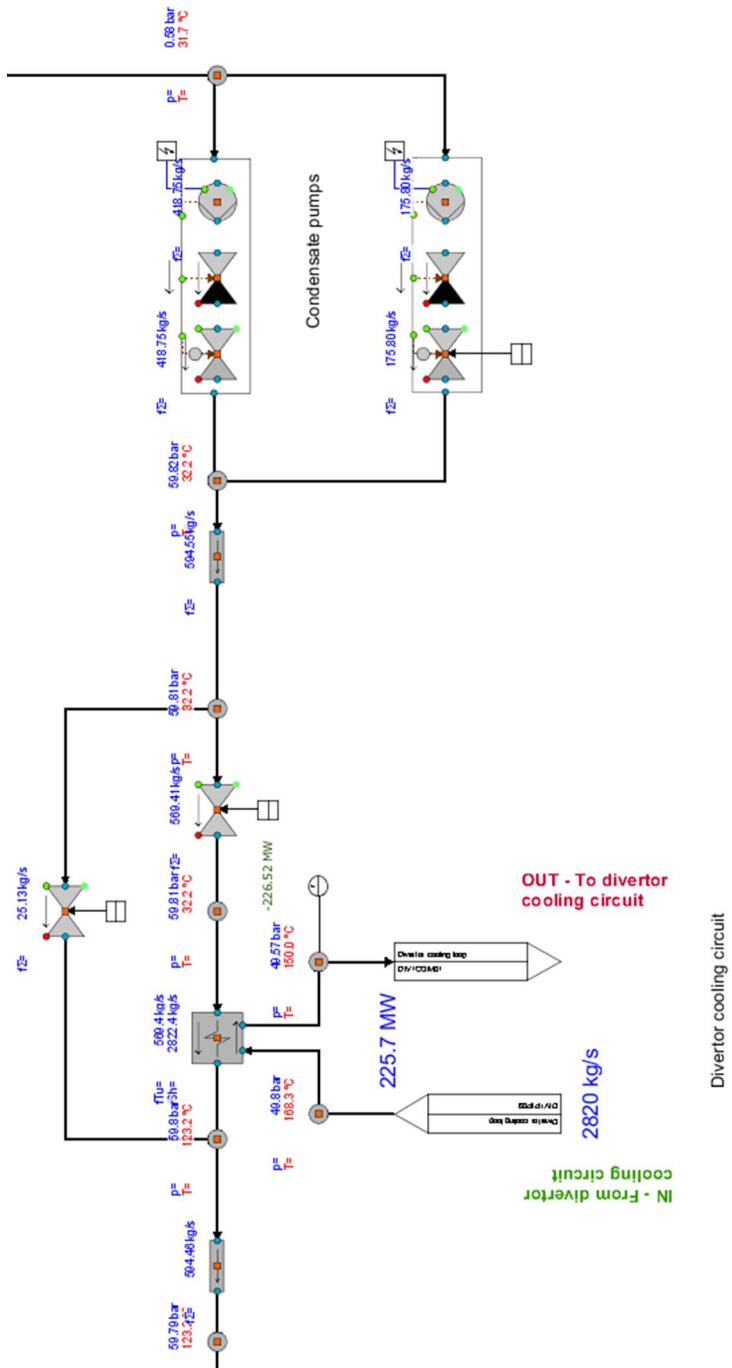

Figure 3.2. Part of power conversion system in the WP BOP Apros-model.

Two analyses cases have been run, a base case with dwell time 30 minutes and a variation with dwell time 15 minutes, adopting experiences from similar analyses in WP PMI, but with newer reference data. The burn operation duration is two hours. In order to preserve the mass balance of the hot and cold tanks of the energy storage system over sequential cycles of burn and dwell, the flow in the energy storage discharge loop must be higher with a shorter dwell time. A higher discharge flow means higher feed water and steam flows and a higher electricity production and a lower variation of molten salt inventory in the tanks. No major differences in the transient behaviour of key parameters were seen, since the heat transfer areas of relevant heat exchangers were scaled according to the increased molten salt discharge flow.

3.3 WP RM: Remote maintenance systems

Research scientists: J. Järvenpää, J. Lyytikäinen, H. Mäkinen, K. Salminen, R. Sibois, M. Siuko, VTT

The divertor cassette handling of DEMO included three subtasks described below.

Assessment of the alternative divertor configurations. Under this subtask two alternative divertor cassette configurations were compared from the remote maintenance perspective. These alternative divertor configurations are:

- 2015 baseline divertor configuration model
- Poloidal division of the divertor in two bodies.

The replacement sequence of the two configurations was compared with the conclusion that the poloidal division of the divertor cassette creates more steps to the divertor installation and removal sequence. Adding steps in remote maintenance operations can result in longer remote maintenance time which has impact on tokamak availability.

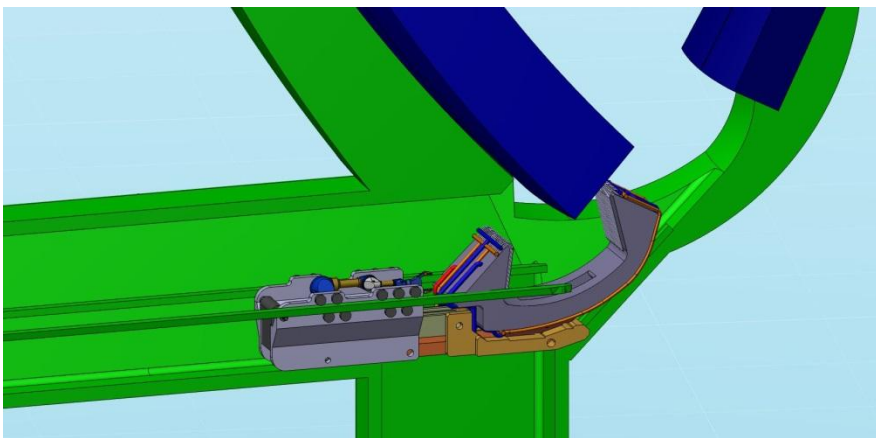

Figure 3.3. One of the divertor cassette transporter concepts.

Divertor Cassette Transporter & Platform. The scope of the subtask was to develop divertor cassette transporter concepts for the AWP 2015 baseline lower port configuration and for the horizontal port option. Requirement analysis for the divertor cassette transporter was carried out. The divertor transportation kinematics for the port options were developed and compared. Two divertor cassette transporter concepts have been developed for the port options. One of the divertor cassette transporters concepts is presented in Figure 3.3.

Divertor Cassette Fixation Development from the remote maintenance perspective. The scope of the subtask was to collect requirements for the cassette fixation and develop conceptual technical solutions from the RM perspective. The work is carried out together by VTT and ENEA/Create. Three divertor cassette fixation concepts were developed by ENEA. ENEA is also working on the cassette itself, so interfaces for the cassette, locking and transportation are easier to fit together.

3.4 WP MAT: Materials

Research scientists: T. Ahlgren, C. Björkas, L. Bukonte, F. Djurabekova, K. Henriksen, P. Kuopanportti, A. Lasa, M. Nagel, K. Nordlund, J. Polvi, E. Safi, A. Sand, V. Tuboltsev, UH

Tungsten (W) is one of the strongest candidates to be used as the divertor plate material for the next step fusion device (ITER) due to its high melting point, low erosion rate, good thermal conductivity and low hydrogen retention. Such combination of properties makes W a promising plasma-facing wall material.

However, continuous bombardment with low energy hydrogen isotopes is seen to introduce defects in plasma facing materials. Open volume defects, such as vacancies, are known to trap hydrogen (H) and thus are the main reasons for H retention in W. In fusion reactors this is a critical issue due to the tritium retention. The presence of H strongly affects most of the W properties, due to phenomena like vacancy formation and blistering. Moreover, H is known to be trapped in impurities, vacancies, dislocations and grain boundaries, affecting the micro-structure evolution of the material. In order to be able to predict and calculate the evolution of the micro-structure, tritium retention, and other thermal and mechanical properties, it is essential to know the H concentration present in the material. The H atom is an endothermic impurity in W with a solution energy of about 1 eV. This means that the equilibrium H concentration in W is very low unless a large H₂ pressure is present at the W surface at high temperature. However, large H flux from the fusion device, can result in concentrations that considerably exceeds equilibrium value in W. This H concentration is proportional to the incoming flux and inverse proportional to the H diffusivity. The H diffusivity, however, is a function of the concentration itself.

We simulated deuterium D diffusion in W with MD, using different D concentrations and temperatures. The results show that the D diffusion coefficient decreases

es drastically with increasing D concentration, see Figure. The decreasing hydrogen diffusion coefficient as a function of concentration might have serious implications for the properties of tungsten material in hydrogen-rich environments. In high hydrogen flux experiments, the concentration of hydrogen in W might become much higher than expected due to the self-induced decrease in the diffusivity. This is especially important at low temperatures as seen in the figure, where the diffusivity reduction as a function of concentration is most pronounced.

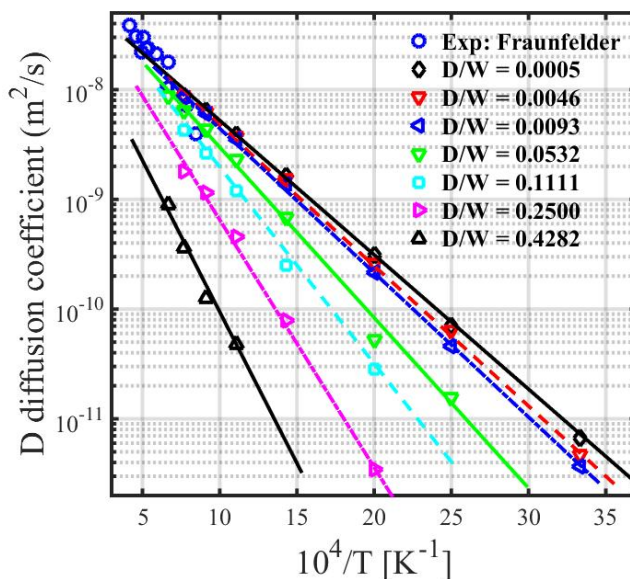

Figure 3.4. The simulated deuterium diffusion coefficients as a function of temperature and D/W ratio. The diffusion coefficient is seen to strongly decrease as the hydrogen concentration increases.

3.5 WP ENS: Early Neutron Source definition and design

Research scientists: A. Helminen, I. Karanta, T. Tyrväinen, VTT

The operational requirements and condition of materials are the same for DEMO as they are for the future commercial fusion reactors. To test the materials a special testing facility called International Fusion Materials Irradiation Facility – DEMO Oriented Neutron Source (IFMIF-DONES) is under design in WP ENS.

The testing of materials calls for long testing periods. During the testing periods the reliable operation of IFMIF-DONES has to be assured. In the testing the materials become radioactive. This sets requirements on the radiation safety and the safety of people working at the facility. In WP ENS Project Level Analysis the safety and the reliability, availability, maintainability and inspectability (RAMI)

aspects of the facility are analysed and the fulfilment of overall requirements are ensured. The analyses provide feedback to design teams of ENS systems and generate documentation for the Preliminary Safety Analysis Report and the Final Engineering Design Report to be filed by the end of 2018.

In 2015, VTT's contribution in WP ENS was to construct a draft probabilistic risk model for one of the systems of IFMIF-DONES. In the study the status of failure modes, effects and criticality analysis (FMECA) was reviewed for the system. After the screening of the potential accidents based on their criticality an example event tree was created for one accident: Erroneous access to the accelerator facility (AF) vault during maintenance shut-down. The accident is presented in the event tree of Figure 3.5. Based on the findings from the study the requirements and needs for a more comprehensive probabilistic risk assessment (PRA) of IFMIF-DONES were outlined.

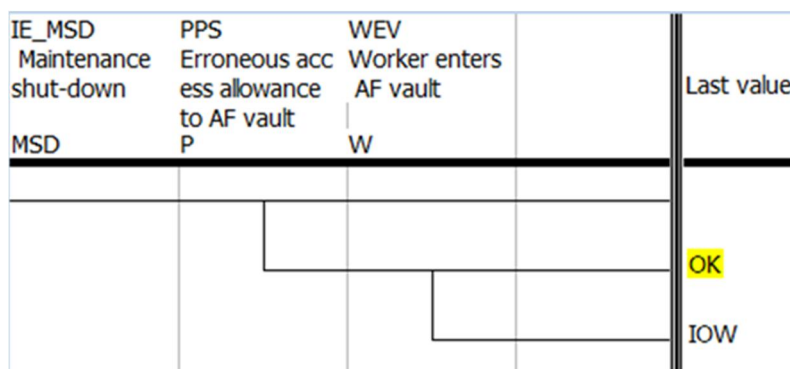

Figure 3.5. Event tree of AF vault access control accident.

4. Public Information

The FinnFusion Annual Seminar was held at VTT, Tampere, Finland, on 25–26 May 2015. The number of participants was 55. The Annual Report, *FinnFusion Yearbook 2014*, VTT Science **91** (2015) 83 p., was published for the Annual Seminar.

VTT organized the EUROfusion FuseCOM Annual Meeting in Tampere on 16–18 June 2015. There were 19 participants from EUROfusion laboratories and the PMU. As the invited guest speaker, Minttu Hietamäki, Fennovoima, presented the Hanhikivi 1 NPP project and Fennovoima's practices in public relations. The meeting included media training for the participants.

During 2015, Finnish and international media published several articles and interviews on the fusion research activities in Finland:

- *F4E and VTT collaboration shines new light on ITER Remote Handling*, F4E News on VTT's remote handling activities, 9 March 2015.
- *VTT:n ITER-yhteistyö jatkuu uutena miljoonahankkeena (VTT's ITER-collaboration continues in a new multi-million project)*, VTT press release on 27 March 2015.
- *ITERin vaativa etähuollon operaatio onnistui suomalaisvoimin (A demanding remote handling operation of ITER successful with Finnish efforts)*, VTT press release on 7 April 2015.
- *VTT ja TTY mukaan Amec Foster Wheelerin 70 miljoonan euron fuusioenergian robotiikkasopimukseen (VTT and TUT join the 70-million euro fusion energy robotics contract of Amec Foster Wheeler)*, VTT press release on 11 May 2015.
- *Suomalaiset toimittavat robotiikkaa Iter-fuusioreaktoriin – Ihminen ei saa mennä sisään (Finland to supply robotics to ITER fusion reactor – human entry not allowed)*, Tekniikka & Talous 11 May 2015.
- *Pertti Peussa, Suomen ITER-yhteistyö sai jatkoa (Collaboration between Finland and ITER continues)*, interview in Tekniikka & Talous, 11 May 2015.
- *Fuusiotekniikka etenee nopeammin kuin Mooren laki (Fusion technology progresses faster than Moore's law)*, Tekniikka & Talous, 5 June 2015.

- Jouko Suokas and Markku Kivikoski, *Suomalaisille suuri fuusioenergian robotiikkasopimus (A large fusion energy robotics contract to Finland)*, interview in Tiedetuubi, 25 June 2015.
- *Fuusioreaktori lähiviikkoina valmis plasmakokeeseen – Saksalaiset tekivät sen, mitä muut pitivät liian monimutkaisena (Fusion reactor ready for plasma in the coming weeks – Germans did what others considered too complex)*, Tekniikka & Talous on W7-X, 25 October 2015.
- *Maailman suurin fuusiokoe käynnistyy tällä viikolla (World's largest fusion experiment starts this week)*, Tekniikka & Talous on the first plasma of W7-X, 2 December 2015.
- Taina Kurki-Suonio, *Uudenlaisen fuusioreaktorin koekäyttö onnistui Saksassa (Successful experimental run of a new type of fusion reactor in Germany)*, interview on the first plasma of W7-X in Helsingin Sanomat, 17 December 2015.
- Taina Kurki-Suonio, *Uudenlaisen fuusioreaktorin koe onnistui (Successful experiment in a new type of fusion reactor)*, interview on the first plasma of W7-X in Tiede, 18 December 2015.

Lecture courses at Aalto University, School of Science:

- *Fusion Technology* (M. Groth, A.E. Järvinen, spring 2015).
- *Fundamentals of Plasma Physics for Space and Fusion Applications* (T. Kurki-Suonio, A. Snicker, spring 2015)
- *Energialukutaito (Energy literacy)* (J. Ala-Heikkilä, T. Kurki-Suonio, fall 2015)

5. Education and Training

5.1 WP EDU – FinnFusion student projects

5.1.1 Overview

After EUROfusion introduced the Education funding instrument, the FinnFusion consortium adopted the practice of nominating *FinnFusion students* to whom the Education funding is specifically directed. The selection is done by the FinnFusion Advisory Board after proposals from the university professors working in the programme. Such a selection is used as an incentive to the students and a strategic means to direct the programme in the long run.

During 2015, six doctoral dissertations and one Master's thesis were completed (see Section 11.5.4).

5.1.2 Doctoral students

Student:	Dario Carfora (VTT)
Supervisor:	Kalevi Huhtala (TUT)
Mentors:	Harri Mäkinen (VTT)
Topic:	<i>Iterative Design Process of DEMO Divertor Remote Handling System using Multicriteria and Participative Approach</i>
Report:	<p>The aim of the research is to develop a novel methodology to support the design process of the RH system for DEMO. A design process converts stakeholder needs and requirements to required functionalities. The methodology shall be based on a Systems Engineering (SE) approach. The process for collection of the requirements and specification for DEMO RH has been started parallel with the concept design phase. As a preliminary supporting case study, the results of the most feasible divertor remote handling scenario were investigated.</p> <p>The current reference scenario of the EU DEMO foresees a 45° inclined port for the remote maintenance (RM) of the divertor in the lower part of the reactor. Nevertheless, from a SE point of view, and especially in the early concept design phase, all possi-</p>

ble configurations shall be taken into account. In this study, different design solutions were compared using an approach based on the Analytic Hierarchy Process (AHP). The technique is a multi-criteria decision making approach in which the factors that are important in making a decision are arranged in a hierarchic structure (Figure 5.1). The results show how the application of the AHP has improved the analysis of decision criteria and focused the selection on the concept which is closer to the requirements arose from technical meetings with the experts of the RH field.

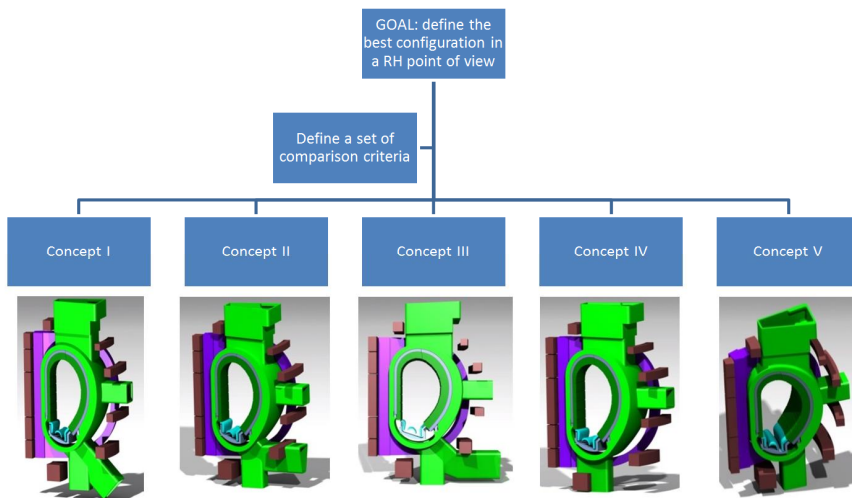

Figure 5.1. The comparison resulted in defining a set of weights matrices, which led to the final scores.

Student: Romain Sibois (VTT)
Supervisor: Timo Määttä (VTT), Kalevi Huhtala (TUT)
Mentors: Ali Muhammad (VTT)
Topic: *Reliability-based design process for the development of DEMO Remote Handling systems using stochastic Petri Nets*
Report: DEMO remote handling systems are an example of complex and multidisciplinary systems, consisting of various technologies performing in severe environment. Therefore the early phases of the design process for such equipment are of primary importance, since it gives the main direction of the system development. The objective of this research aims at developing a novel simulation-based design process for the development of complex systems such as DEMO remote handling systems. The method enables to quantitatively assess different design options based on a predictive reliability approach using stochastic

Petri Nets. During this thesis, DEMO has been used as a case study and the main results have been obtained. The method consists of modelling the high level operational sequence of the reactor maintenance operations as a stochastic Petri Net. Systems and subsystems are essentially broken down to gain insight into its compositional components and their respective reliability behaviours. Functional and dysfunctional stochastic Petri Nets of systems and subsystems are implemented into the high level operational sequence together with various environmental factors. The reliability of different concepts is obtained and compared to determine which design option offers a higher reliability regarding a particular task, subtask or the entire remote handling sequence. The main outcomes of 2015 include the application of the method to DEMO case study and writing of doctoral dissertation.

- Student:** Paula Sirén (VTT)
Supervisor: Filip Tuomisto (AU)
Mentors: Jaakko Leppänen (VTT)
Topic: *Generating fusion plasma neutron source for Serpent MC neutronics computing*
Report: A realistic neutron source for introducing the Serpent MC code in fusion applications is generated with the AFSI Fusion Source Integrator. An ITER baseline $Q=10$ plasma with D/T mix (50%/50%) has been used as a demonstration case, as presented in Figure 5.2, where the neutron production rate is given by AFSI in (R, z) coordinates.
Benefits of AFSI compared to previously applied methods based on simplified analytical approximations of plasma parameters, such as T and n, include better accuracy of the source geometry and possibility to include all reaction types to the analysis. In addition, AFSI is capable of coupling the neutron source definition to time-dependent plasma transport simulations, which is useful in analysis of yet non-existing devices, such as ITER and DEMO. Several development steps in the AFSI-based neutron source have been planned. Generating anisotropic (thermal-fast and fast-fast particle reactions) fusion reaction product distributions and energy spectrum are under construction. First results of neutron energy spectra were calculated with JET data and AFSI will be utilised as synthetic neutron diagnostics in forthcoming JET experiments.

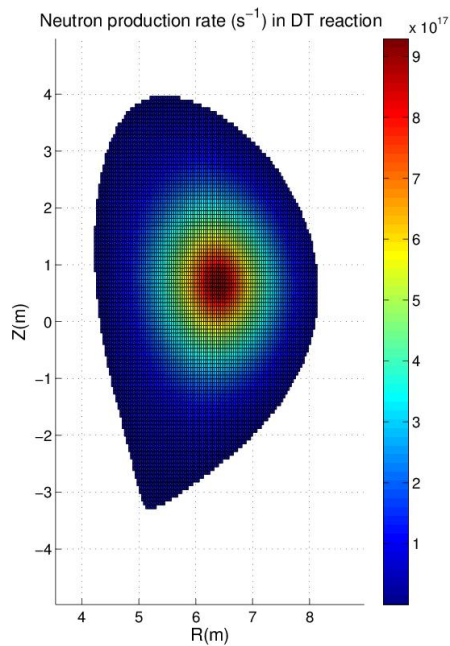

Figure 5.2. Neutron production in DT reaction in ITER baseline plasma.

Student: Jukka Väyrynen (TUT)
Supervisor: Jouni Mattila (TUT)
Mentors: Jouni Mattila (TUT)
Topic: *RAMI requirements management*
Report: The maintenance operations in ITER must be performed safely and within specified time limit so as to not cause unwanted delays in the plasma operations. For this reason, reliability requirements have been set for the ITER Divertor Remote Handling System (DRHS). This requirements specification, however, is a top-level enveloping requirements set and distributing it among the devices and systems comprising the DRHS. Objective of this research has been to develop a framework for allocating the high-level requirements to the lower level equipment and systems. This framework and relevant real-life failure data from CCFE RH operations was presented in the annual FinnFusion seminar in 2015.

Student: Laura Bukonte (UH)
Supervisor: Kai Nordlund (UH)
Mentors: Tommy Ahlgren (UH)
Topic: *Defect evolution in materials*
Report: Work reported as part of WP MAT (Section 3.4).

Student: Aaro Järvinen (AU)
Supervisor: Mathias Groth (AU)
Mentors: Mathias Groth (AU)
Topic: *Interpretative simulations of impurity seeded JET ELMy H-mode plasmas*
Report: In this thesis radiative divertor operation in nitrogen and neon seeded, high-triangularity JET H-mode plasmas have been experimentally investigated and simulated with EDGE2D-EIRENE in horizontal and vertical LFS divertor configurations. The simulations show no substantial difference between the two configurations in the reduction of the peak heat flux at the LFS divertor plate as a function of the divertor radiation, consistent with experimental observations. With nitrogen seeding, both configurations reach detached conditions at the LFS plate in the experiment. When imposing the measured levels of divertor radiation with nitrogen seeding, the measured reduction of the LFS divertor saturation currents are captured by the EDGE2D-EIRENE simulations in both configurations. However, when imposing the divertor radiation with nitrogen, the divertor deuterium-alpha emissions are still underestimated by a factor of 2–5 indicating a short-fall in radiation by the fuel species in detached conditions.

Student: Juuso Karhunen (AU)
Supervisor: Mathias Groth (AU)
Mentors: Mathias Groth (AU), Antti Hakola (VTT)
Topic: *Spectroscopic studies of material migration and deposition in fusion devices*
Report: Toroidal and poloidal SOL flows of injected nitrogen impurities were studied on the high-field side of ASDEX Upgrade by applying Doppler spectroscopy on emission lines of N⁺ ions. The measurements were performed during six L-mode discharges with different core densities, causing the inner divertor target to range from high-recycling to detached conditions during the experiment. The observed flows are mainly directed towards the inner divertor. Close to the separatrix, the results suggest reversal of the flow direction toroidally in high-recycling conditions and poloidally in all cases. The equilibration of the N⁺ flow with the background D⁺ flow is studied by SOLPS and ERO simulations.

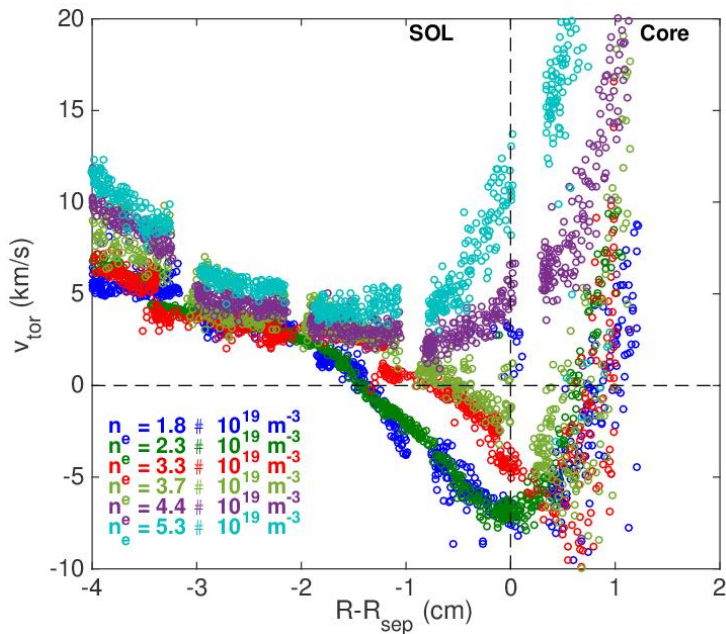

Figure 5.3. Toroidal flow velocity profiles observed in six AUG discharges using Doppler spectroscopy.

Student: Fredric Granberg (UH)
Supervisor: Kai Nordlund (UH)
Mentors: Kai Nordlund (UH)
Topic: *Modelling of Dislocation Interactions with Obstacles in Fusion Reactor Structural Materials*
Report: The interaction of edge dislocations with different obstacles was investigated by Molecular Dynamics simulations. Nine different obstacles of different types and shapes were investigated at different temperatures and for different sized obstacles. We have determined the needed stresses for edge dislocations to unpin from the obstacles. Also the mechanisms present during the unpinning phenomenon were determined. We have determined the strength order of different obstacles and also showed the effect of obstacle nanostructure in the unpinning event. The results showed that the obstacles exhibiting the same unpinning mechanism showed similar unpinning stresses, with some differences depending on the obstacle nanostructure.

Student: Paavo Niskala (AU)
Supervisor: Mathias Groth (AU)
Mentors: Timo Kiviniemi (AU)
Topic: *Study of flow dynamics and its effect on confinement in tokamaks*
Report: The student has studied the interaction of flows and turbulence in fusion plasmas via advanced computer simulations. The gyrokinetic simulations have been compared to experimental measurements at the FT-2 tokamak. The investigation has focused on temporally oscillating flows, also known as the Geodesic Acoustic Mode (GAM). Both experiments and simulations have demonstrated such oscillations in the plasma. Additionally, similar oscillations have been observed in the turbulence, an indicator of the interplay between the two phenomena. The collaboration continues by concentrating on the impact of the fuel isotope. Early results already show that increased ion mass boosts flow amplitudes, reduces particle transport, and enhances the interaction between turbulence and flows.

Student: Elnaz Safi (UH)
Supervisor: Kai Nordlund (UH)
Mentors: Carolina Björkas (UH), Jussi Polvi (UH)
Topic: *Multiscale modeling of plasma-wall interactions: (i) Multiscale modelling of Be-D interactions under reactor-relevant parameters; (ii) Atomistic simulations of D irradiation on Fe-alloys in ITER vacuum vessel*

Report: Extensive experimental work on Be exposed to D plasmas can be found in literature. These experiments provide a broad database for Be erosion yields, but unfortunately they have not fully described the relationship of surface temperature with D concentration at the surface and the underlying mechanisms. However, these accurate beryllium deuteride (Be-D) molecular erosion yields can be computed using a molecular dynamics and object kinetic Monte Carlo (MD-OKMC) multi-scale approach, allowing a more detailed description of the complex relationship with and between surface temperature and D concentration. In our work, first we used OKMC technique to determine equilibrium D profiles in Be varying the vacancy concentration (0–20%) and surface temperature (300–800K). Then, the D and vacancy profiles from OKMC were used to set-up Be substrates for the MD irradiation simulations that represents surface morphologies in long-term equilibrium. Be-D molecular erosion yields were studied by irradiating these cells with D, with energies 10–200 eV, and also scanning over different surface temperatures (300–800K). Our OKMC results show that there is almost linear dependence between D concentration and vacancy concentration while sur-

face temperature has a significant effect on D depth profile. We will show the Be erosion results from MD simulations in more controlled conditions. The benefits of a simple multi-scale scenario, including long-term effects and resulting in a more reliable erosion database will be highlighted in this work.

Student: Jing Wu (LUT)
Supervisor: Huapeng Wu (LUT)
Mentors: Huapeng Wu (LUT)
Topic: *Control of remote controlled robot for fusion reactors*
Report: EAMA is an articulated serial manipulator working in EAST vacuum vessel for inspection and maintenance. An object optimization algorithm is designed to suppress end-effector movement vibration by minimizing jerk RMS (root mean square) value. An open software architecture for the EAMA is developed, which offers a robust and proper performance and easy-going experience based on standard open robotic platform OROCOS. Two papers were published (see the list of publications in Section 11.5).

Student: Aki Lahtinen (UH)
Supervisor: Jyrki Räisänen (UH)
Mentors: Antti Hakola (VTT), Jari Likonen (VTT)
Topic: *Plasma-wall interactions in fusion devices*
Report: In 2015, the work concentrated on analysing deposition and erosion profiles of tungsten (W) using Rutherford Backscattering Spectrometry (RBS) and deposition of deuterium (D), boron (B), carbon (C) and nitrogen (N) using Nuclear Reaction Analysis (NRA) on samples originating from the following experiments in ASDEX Upgrade (AUG): Nitrogen migration and implantation in first wall and Tungsten fuzz and power load studies in helium. Considering the nitrogen experiment, only the W samples with a smooth surface showed net erosion, with the largest peak coinciding with the outer strike point, while nitrogen was measured to have been deposited on all the exposed probes, with the inventories on rough samples being two times higher than those on smooth samples. For the helium experiment, analyses showed that the entire outer divertor was a net deposition area, with the deposited layers containing high amounts of W, D, B, C and N. The results showed also a roughness effect: deposition was higher for rough than smooth surfaces.

5.2 WP TRA – EUROfusion Researcher Grant

Particle source and edge transport studies in JET H-mode gas puff modulation experiments

Research scientist: A. Salmi, VTT

JET experiments to study particle transport and plasma fuelling have been conducted and analysed using 1.5D core transport simulations and EDGE2D/EIRENE modelling in the scrape-off layer. These experiments feature periodic modulation of the gas fuelling to induce a small but clear response in plasma density ($\Delta n/n \sim 1\%$). The resulting density wave contains extra information that allows deducing the prevalent particle transport properties (diffusion + convection) separately. Using iterative forward modelling scheme including realistic geometry and NBI source it was possible to find smooth and unique transport profiles that were able to explain both the steady state and perturbation properties up to 3rd harmonic within measurement error.

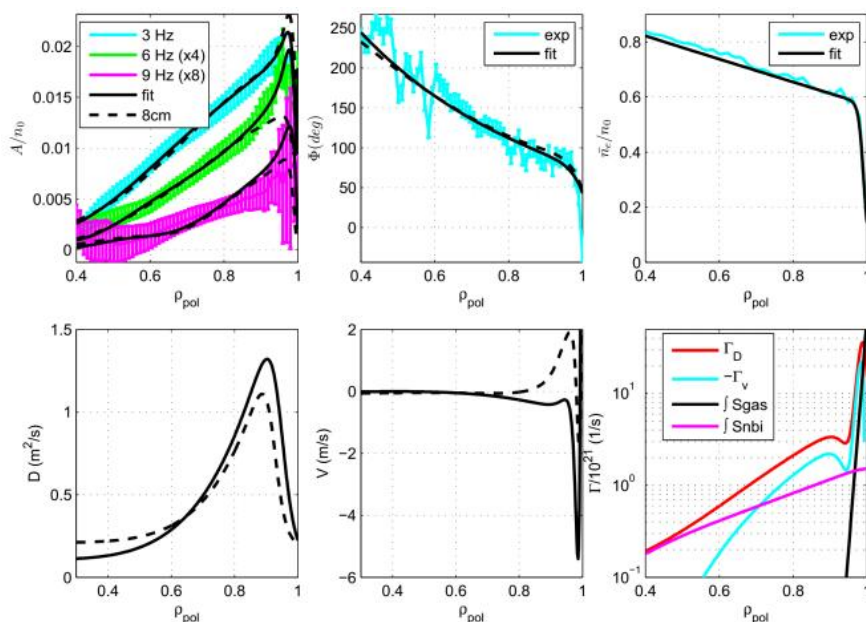

Figure 5.4. Top row: Electron density relative modulation amplitude, phase and steady state profiles. Bottom row: inferred transport and fluxes by channel for JET pulse #87420.

Figure 5.4 shows the result for the best fit (full black line) and forced source width (dashed black line). The main conclusion from this discharge for both shown

cases is that density peaking is largely due to the particle source from NBI. Further experiments are scheduled to assess the generality of this result. If found to be robust it would likely mean that ITER density profiles will not be peaked as predicted when using JET steady state data only.

The difference between full and dashed line simulations tells that it is more likely that neutral penetration through the separatrix is very shallow and that inward particle pinch near the separatrix is needed to fuel the plasma beyond the edge transport barrier. Preliminary EDGE2D/EIRENE simulations support the narrow source width but work is still ongoing together with collaborators to improve the simulations to better match the measured fuelling dynamics (as seen from wide angle camera measurements of D_{β} line radiation).

5.3 WP TRA – EUROfusion Researcher Grant

Static and dynamic parameter calibration of multipurpose deployer for DEMO in-vessel remote maintenance

Research scientist: Yongbo Wang, LUT

This two-year project AWP15-ERG-VTT/Wang started in March 2015. One objective is to develop an efficient robot calibration system for the accurate and rapid identification of static and dynamic parameters of the potential DEMO remote maintenance manipulators. Another objective is to theoretically and experimentally determine what kind of error sources, the static or dynamic errors, is more important for improving the accuracy of manipulator.

A general case study of a 6-DOF (degrees of freedom) commercial industrial serial robot and a 10-DOF redundant hybrid ITER welding/cutting robot (IWR) at Lappeenranta University of Technology have been used to carry out the corresponding simulation and experimental studies. Currently, the kinematic error modeling is completed and the preliminary dynamic error model of a 6-DOF industrial manipulator has been established. Furthermore, different measurement sensors and measurement methods have been investigated for the static calibration of a 6-DOF industrial manipulator. An optical vision system has been proposed as measurement sensor to acquire end-effector information to calibrate robot (see the figure). To find the error parameters, different global optimization methods such as MCMC, Differential Evolution (DE), Neural Networks and particle swarm optimization (PSO) algorithm have been investigated. The implementation of the identified parameters involves control algorithm. To this end, a hybrid position-force control system will be investigated during this year after computer simulation work being completed.

The results found in this research would be extrapolated to form the basis of the proposed future connection with the work undertaken to support the ITER or the future DEMO remote handling systems.

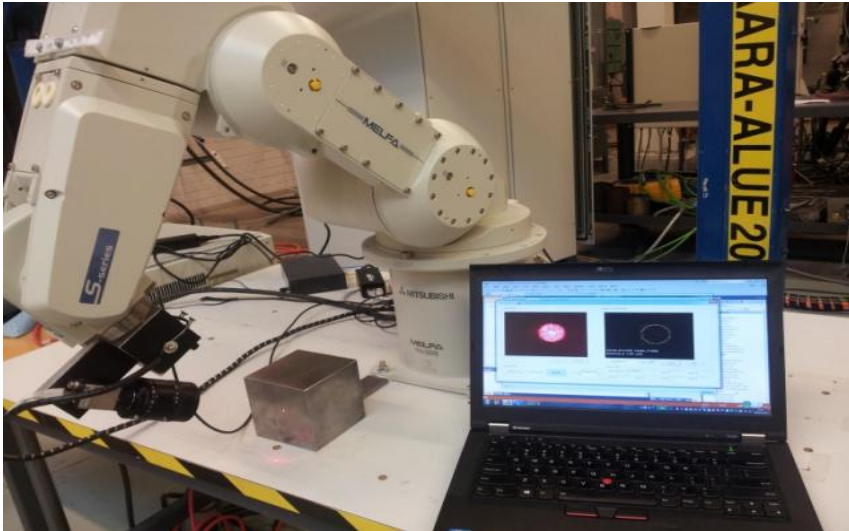

Figure 5.5. Camera-based Optical calibration system.

5.4 WP TRA – EUROfusion Engineering Grant

Design of control systems for remote handling of large components

Research scientist: Ming Li, LUT

The remote handling of large components plays a crucial role in the In-Vessel assembly and maintenance of DEMO. The required positioning tolerance of remote handling of large components, such as blanket modules, is expected to be tens of millimetres. However, due to the massive weight of the object components, the large structural dimensions of both object components and its handling manipulators, the magnitude of the deformations of the entire handling system are considerably large. Additionally, the elevated temperatures, some level of magnetization and the gamma radiation also affect, to some extent, the structural deflection of the remote handling system.

An adaptive position control system has been developing, which takes into account the aforementioned effects on the handling system, in order to get the satisfactory operation accuracy. The control system will be implemented as a software system capable of controlling the remote handling systems for the DEMO reactor maintenance. For the blanket segments maintenance represent one of the most challenging tasks overall, the removal of the MMS will be taken as the use case of developing the remote handling control system.

The computation-effective deformation model of the handling system will be developed based on the continuum mechanical modelling and simulation theories, and will be incorporated into the controller design to compensate the structural

deformation. The combination of the matrix structural analysis method, the virtual joint method, along with applying the virtual work principle, is an effective solution to compute the robotic structure deformation in real-time. The artificial neural network is also successfully applied to compute the deformations of the complex structure, and is foreseeable to be applied to predict the deformations caused by the temperatures, magnetization and gamma radiation, which contain complex models.

In the control system, the compensation to the inverse kinematics of the remote handling system will be implemented in every interpolation points of the desired operation trajectory, however, the kinematics of the handling system is varying due to the deformation, and the intelligent inverse computation algorithm also needs to be developed.

The developed control system is foreseeable to be applied to various handling systems. Generally, the adaptive control system is a fairly self-contained unit which interfaces with: the hardware of the robotic handling system; the sensors in-vessel, ex-vessel, and on the transporter; and the structural simulator. Figure 5.6 shows the general concept of applying the on-line adaptive control system on a general hardware environment.

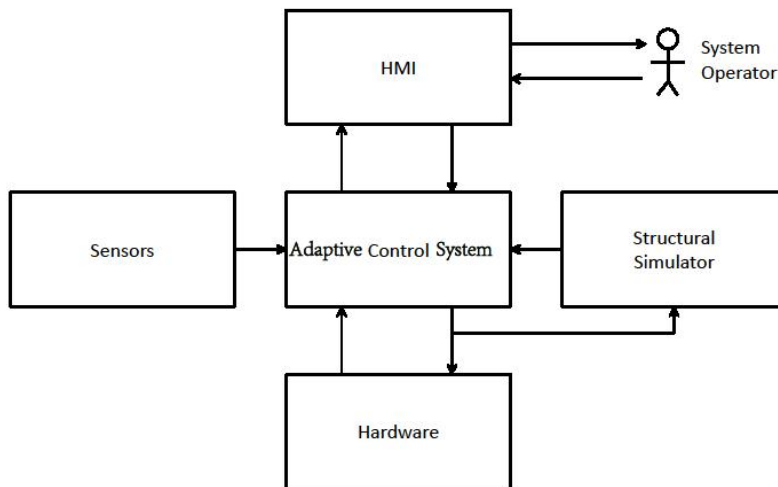

Figure 5.6. Online adaptive control system.

6. Enabling Research

Research scientists: M. Groth, A. Järvinen, T. Kiviniemi, T. Kurki-Suonio, S. Leerink,
P. Niskala, AU
K. Heinola, UH
J. Likonen, VTT

FinnFusion participated in four Enabling Research projects in 2015:

- AWP15-ENR-01/CCFE-03: Predictive model for pedestals
- AWP15-ENR-01/CCFE-08: Tritium and Deuterium retention in metals with variable radiation-induced microstructure
- AWP15-ENR-01/CEA-09: Kinetic modelling of runaway electron dynamics
- AWP15-ENR-01/IPP-01: Verification and development of new algorithms for gyrokinetic codes (NumKin)

In this report we highlight the project AWP15-ENR-01/IPP-01. The gyrokinetic full-f Particle-In-Cell code ELMFIRE is taking part in the linear verification of Geodesic Acoustic Modes (GAM) as part of NumKin project. Other gyrokinetic codes involved in the GAM verification project are NEMORB, GENE and GYSELA.

Geodesic acoustic modes are oscillations measured in tokamaks characterised by a potential perturbation in the zonal flow and a $m=1$ perturbation in the density. GAM's play an important role due to their nonlinear interaction with turbulence. A detailed linear verification process is at the basis of the development of a gyrokinetic code aimed at rigorous investigations of turbulence and flows.

In the first phase of the verification process the frequency and damping rate of GAMs are benchmarked to the theoretical formulas derived in the limit of small radial wavenumber and small values of the safety factor. So far the focus has been on regimes where the effect of the ions' finite-orbit-width can be considered only at the first order, corresponding to small radial wavenumber, and small values of safety factor. The first benchmark results of the ELMFIRE code show a good agreement of the GAM frequency and a thorough scan of the dependence of the GAM frequency on the safety factor will be completed in 2016. Other planned milestones for 2016-2017 within the NUMKIN project are the GAM dependence studies of the effect of ion finite-orbit-width and kinetic electrons.

7. NJOC and PMU

7.1 Overview

Three FinnFusion scientists were seconded to work in the new JET operating contract team (NJOC) and one scientist in the EUROfusion Programme Management Unit (PMU) during 2015. This section highlights the PMU project. The three NJOC duties were:

- NJOC Neutron Diagnostic Specialist, Marko Santala, AU
- NJOC ASCOT Code Responsible Officer, Tuomas Koskela, AU
- NJOC Plasma-Wall Interaction Physicist, Kalle Heinola, UH.

7.2 EUROfusion PMU WP JET1 Responsible Officer

Research scientist: J. Lönnroth, AU

J. Lönnroth has served as WP JET1 Responsible Officer in the EUROfusion PMU at JET since the inception of EUROfusion. In his role he has been part of the team responsible for managing the entire JET experimental programme.

Among the various responsibilities this entails, J. Lönnroth has had particular responsibility for coordinating the manning of the JET experimental campaigns with scientists from across EUROfusion. This has involved preparing calls for participation, selecting participating scientists in collaboration with the leadership of the scientific task forces at JET and managing changes to the agreed manning on a daily basis in response to changes in the experimental timeline and due to individual needs, as well as making sure budgetary constraints are not exceeded.

J. Lönnroth has also played a key role in designing a new Information Management System for EUROfusion. This system will be used as a manning database for all EUROfusion experimental devices and for managing projects across all EUROfusion Work Packages. Other responsibilities have included monitoring research activities and code development, deciding on programmatic priorities together with the rest of the PMU team and the scientific task forces, liaising with the technical operator of the JET facility on issues such as machine availability and performance, licensing numerical codes for use outside EUROfusion and serving as a member of the JET Programme Execution Committee.

8. International collaborations

8.1 DIII-D tokamak

Research scientists: M. Groth, AU
A. Salmi, T. Tala, VTT

8.1.1 Plasma detachment studies

M. Groth visited the DIII-D National Fusion Facility in San Diego, California, USA, in November and December of 2015 to investigate detached plasmas, and the role of cross-field drifts and deuterium molecules in obtaining detachment. The fluid edge code EDGE2D-EIRENE was set up for two sets of DIII-D L-mode plasmas that were extensively analysed for their detachment characteristics: radiated power, power and ion fluxes to the plates, and, uniquely, the 2-D distributions of electron density and temperature, and deuterium and low-charge state carbon emission. Density and power scans were performed with EDGE2D-EIRENE. Running without cross-field drifts qualitatively reproduces the functional dependence of the divertor plasma conditions on upstream density, but do not quantitatively equal the experimental data. Cases with cross-field drifts included yet not successfully converged; hence these studies will be continued in 2016. Inclusion of ion-molecule interaction previously showed, for example, to produce sub-eV divertor plasmas, in better agreement with the experiments. This work is carried out in close collaboration with Dr. Adam McLean for Divertor Thomson scattering measurements, and Dr. Steve Allen for a new coherent-imaging camera.

8.1.2 ρ^* scaling of intrinsic torque

T. Tala and A. Salmi visited General Atomics (San Diego, USA) for the DIII-D part of the ITPA TC-17 experiment where the purpose is to find ρ^* scaling for intrinsic torque in an effort to predict ITER intrinsic rotation with more confidence. Similar experiment had already been conducted on JET and AUG. In present tokamaks the plasma rotation in the absence of external drive (read w/o NBI) has been widely reported yet due to its smallness in current devices it has remained elusive and predictions for ITER require a large leap in faith. Dedicated experiments using NBI

modulations were planned together with local hosts and executed successfully. A key point was to match JET (and AUG) shapes at an identity point matching as many dimensionless parameters as possible (ρ^* in particular) to allow finding suitable normalisations for extrapolating the multi tokamak data for ITER. Results were/are presented in several conferences in 2015/2016.

8.2 Ioffe Institute

Research scientists: T. Kiviniemi, T. Korpilo, S. Leerink, P. Niskala, AU

A long-standing collaborative effort is in place between Aalto University and the Ioffe Institute in St Petersburg regarding code validation of the gyrokinetic full-f global code development project ELMFIRE to turbulence measurements at the large aspect ratio tokamak FT-2. The main focus has been on coherence studies between particle and heat transport and fluctuations of the density and potential, with special emphasis on the role of the geodesic acoustic mode in obtaining increased confinement regimes. For this purpose synthetic diagnostics for several reflectometer diagnostics have been incorporated into the ELMFIRE code. Turbulence modulation at the GAM frequency is for the first time supported by experimental observations at the

FT-2 tokamak and confirmed by ELMFIRE simulations, predicting strong modulation of the electron thermal diffusivity induced by GAMs, which propagates inward and possesses the GAM temporal and spatial structure. In order to obtain energy power balance in the simulations the transport shortfall observed mainly in the ion channel near the plasma boundary needs to be understood in more detail. For this purpose an in-depth study of the scaling of the energy confinement time is planned for 2015–2017.

9. Full-f gyrokinetic turbulence code ELMFIRE

Research scientists: T. Kiviniemi, T. Korpilo, S. Leerink, P. Niskala, AU

The investigation of the isotope effect in multi-scale anomalous transport phenomena was performed with gyrokinetic Elmfire modelling in comparable hydrogen and deuterium FT-2 tokamak discharges and compared to experimental results obtained with highly localized turbulence diagnostics. Substantial excess of the GAM amplitude, radial wavelength and correlation length in a wide spatial region of deuterium discharge resulting in stronger modulation of drift-wave turbulence level was demonstrated by the both approaches. The gyrokinetic modelling demonstrated comparable level of drift wave density and electric field fluctuations in hydrogen and deuterium discharges, nevertheless, the mean value of the particle anomalous flux provided by modelling shows the systematic isotope effect at all the radii.

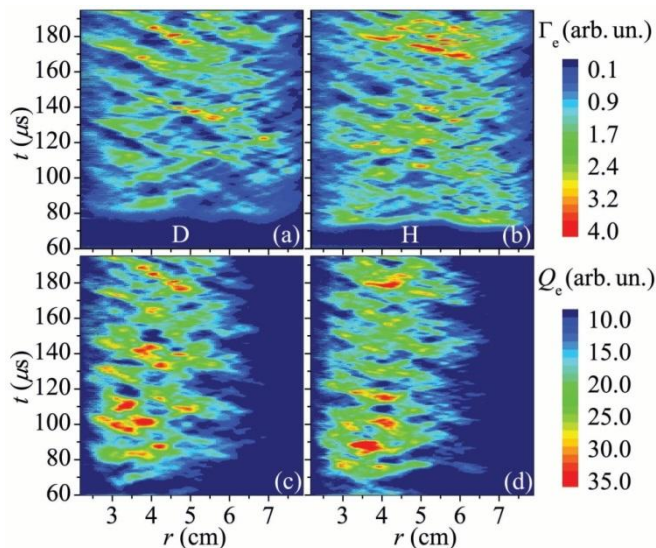

Figure 9.1. Flux surface averaged turbulent fluctuations in radius and time.

The poloidal electric field fluctuation levels are compared in Figure 9.1 (a) and (b), and $\delta E_\theta \delta n$ in Figure 9.1 (c) and (d) where also strong modulation at the GAM frequency is demonstrated which more pronounced in D-discharge. The time-averaged values, however, for 1a and b are similar but direct computation of the MHD radial turbulent particle flux $\Gamma = \langle \delta E_\theta \delta n \rangle / B$ shows systematically higher time average in H-discharge in comparison with D-case which can be explained only by the difference of relative phase of density and electric field fluctuations in hydrogen and deuterium which in deuterium should be closer to $\pi/2$ than in hydrogen.

ELMFIRE was also used to simulate the impact of turbulent tokamak plasma transport on the edge plasma flow and scrape-off-layer width. The simulation was performed in the circular limiter configuration and extends from the magnetic axis to the material surface. The results show that the sheath potential and parallel Mach number are in agreement with theoretical predictions, while the $\mathbf{E} \times \mathbf{B}$ dynamics are strongly affected by the sheath boundary. The radial fall-off of density and temperature profiles show non-exponential behaviour in the scrape-off-layer.

The linear growth of turbulence in Elmfire modelling has been characterized and the results are consistent with GS2 turbulence code. OpenMP/MPI Hybrid code version of Elmfire is under development. The current stage involves testing and benchmarking of the code. The first results for EUROfusion code verification activity on GAMs have been obtained as reported elsewhere in this book.

ELMFIRE work was supported by WP EDU, Academy of Finland and Tekes as well as computer resources from IFERC and CSC.

10. Fusion for Energy activities

10.1 Effect of the European design of TBMs on fast ion power loads in ITER

F4E grant: GRT-379, "RIPLOS-2"
Research scientists: O. Asunta, T. Bergmans, T. Kurki-Suonio, A. Snicker, S. Sipilä, K. Särkimäki, S. Äkäslompolo, AU

Year 2015 marked the completion of the 3.5-year-long project F4E-GRT-379, the purpose of which was to assess the possible effect that introducing the European He-cooled pebble bed design of the test blanket modules might have on the fast ion power loads in the four major operating scenarios of ITER: the 15 MA baseline, the 12.5 MA hybrid, the 9 MA advanced, and the 7.5 MA half-field He-plasma scenario. The process had three major parts.

In the first phase, the 3D magnetic configurations were calculated using a combination of a commercial FEM solver called COMSOL and a domestic Biot-Savart solver. The necessary input from F4E consisted of the CAD drawings of the coils and the ferritic components, together with the plasma equilibrium that gave the plasma current profile. In this project, all three ports reserved for the TBMs were occupied with the ones of the European design.

In the second phase, the response of the plasma to the external perturbations was obtained from a complementary F4E project OPE-650, in collaboration with CCFE.

The third phase consisted of the wall power load simulations using the domestic ASCOT code. Three species of fast ions are of interest: the 3.5 MeV fusion alphas, the 1 MeV deuterons from neutral beam injection, and tritons in MeV range produced by ICRH. However, the source for the ICRH-accelerated tritons could not be made sufficiently efficient for ITER-scale simulations within this project. For each scenario, up to six magnetic geometries are simulated: one with FIs only, another where the TBMs are also included, and yet another where even the effect of the ELM control coils (ECC) are accounted for. Each of these is accompanied by a corresponding magnetic geometry where even the plasma response is included.

Introducing the European design of the TBMs was not found to jeopardize the integrity of the ITER first wall in any of the scenarios. The effect of the TBMs on fast ion confinement cannot be given as a simple number telling how much they deteriorate the confinement and increase the load. Rather, it was discovered that if the confinement was good in their absence, introducing TBMs could double the power load (15 MA baseline scenario). In contrast, if the losses were significant already without TBMs, introducing them increased the loads only by 10 % (12.5 MA hybrid scenario). In either case, TBMs are unlikely to cause power loads at problematic level.

While the TBMs were found benign from the fast ion power loads point-of-view, introducing the ECCs increased the fusion alpha power load to MW range in the 15 MA baseline scenario. Fortunately, the power increase was predominantly to the divertor. Furthermore, the effect of plasma response was to bring this down to about 600 kW. The ECCs had the most dramatic effect on beam ions: while the beam power load with just FIs and TBMs was in the kW range for both first wall and divertor, introducing the ECCs brought the divertor load up to 0.5 MW. The ECC-induced changes in the first wall power loads were small compared to this. The effect of ECCs in the 9 MA advanced scenario was found similar but significantly smaller. This implies that the ECC effect is limited to the very periphery of the plasma, so that only in cases where the fast ions are well confined in that region can ECCs produce an alarming increase in the wall power loads.

10.2 System level design for the Remote Handling Connector and ancillary components

F4E grant:

F4E-FPA-328-SG05

Research scientists:

H. Saarinen, H. Mäkinen, J. Lyytinen, P. Tikka, P. Kilpeläinen, H. Martikainen, S. Rantala, R. Tuominen, T. Määttä, K. Salmi-nen, M. Siuko, VTT

The Remote Handling Connector (RHC) project is part of F4E Framework Project Agreement (FPA) with a Hungarian consortium, where VTT is one partner. VTT has been concentrating on the Divertor RHC development within a special grant (SG05).

21 of 54 divertor cassettes contain diagnostics sensors. The purpose of the RHC is to connect divertor cassette diagnostics sensors to ex-vessel diagnostics while also enabling remote exchange of the divertor cassettes. The amount of diagnostics signals varies but in the most challenging case the amount of signals to be connected is over 200.

The goal of the grant is to design RHC at system level and support the design through mock-up testing. The design should represent the initial design phase of the final connector taking into account space limitations, harsh environment requirements (thermal load, irradiation, vacuum) and needs for reliability and remote handling ability.

During the project execution a newly developed Share Point based project management tool has been implemented. This tool is based on the Systems Engineering approach and can be developed further for other applications as well. The tool was utilized when altogether about 400 requirements were analysed from the applicable documents and collected as the requirement list of the RHC. Functional and corresponding performance requirements were extracted and conducted from the requirements. Also criteria for evaluating upcoming concepts are established.

The work will continue in 2016 with creation of the concepts and selection of the option (one of which is shown in Figure 10.1) to be further developed in the next phase of the FPA. The DTP2 platform plays very important role in the development task with testing the mock-ups and the final connectors. The special connector types and the development of demanding remote operated connectors can constitute new special products for industry.

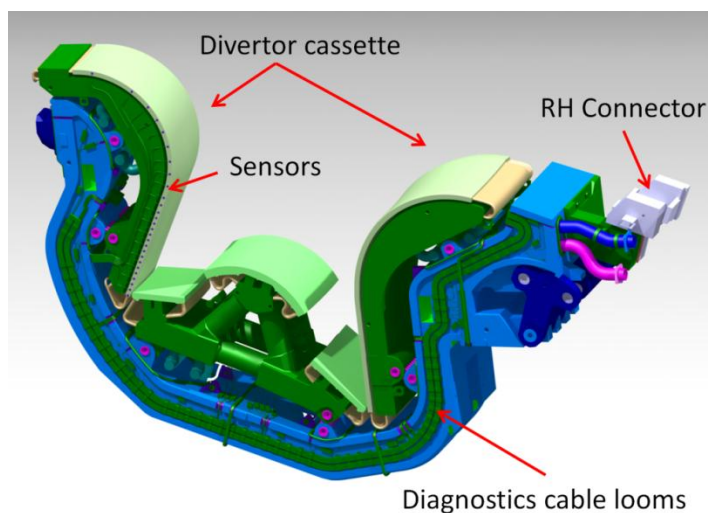

Figure 10.1. One option for the location of the divertor RH connectors.

10.3 Optimisation of the Divertor Central Cassette maintenance operation

F4E grant:

F4E-GRT-0628

Research scientists:

H. Mäkinen, H. Saarinen, K. Salminen, V. Hämäläinen,
T. Määttä, VTT

The maintenance of the Divertor Central Cassette (CC) in ITER reactor needs remote operation. To enhance the reliability of the operation with CC new ideas were tested in DTP2. The ideas have been developed for the installing of locking

pins of the Central Cassette Outer Rails to a novel side blade construction. The focus was to use lower pins as target locking points and with those pins lift the CCOR in its right position. Modular pin hole structures were used for the assembly of the side plates. Several test plans were created and tested by a computer simulation models. These results will be used for the real functional tests in DTP2. Results of the implementation of computer models and simulation for functional tests were positive and the tests will take place in early 2016. The idea of modular structures was also demonstrated. The project gave good information and expertise on the implementation of simulated functional tests and modular structures for demanding and complex mechanical systems.

11. Other activities

11.1 Missions and secondments

Antti Hakola to EPFL (Swiss Confederation), 18–23 Jan 2015 (WP JET1)

Jari Likonen to CCFE (United Kingdom), 19–30 Jan 2015 (WP JET2)

Mathias Groth to General Atomics, San Diego, California, USA, 4–22 Feb 2015 (International Collaborations)

Jari Likonen to CCFE (United Kingdom), 19–27 Feb 2015 (WP JET2)

Leena Aho-Mantila to IPP (Germany), 22–28 Feb 2015 (EDFA Fellowships)

Leena Aho-Mantila to IPP (Germany), 1–14 Mar 2015 (WP PMI)

Tuomas Tala to Institute for Plasma Research, 7–13 Mar 2015 (International Collaborations)

Taina Kurki-Suonio to ITER Organization (France), 5–27 Mar 2015 (International Collaborations)

Antti Hakola to IPP (Germany), 9–13 Mar 2015 (WP PFC)

Otto Asunta to IPP.CR (Czech Republic), 16–20 Mar 2015 (WP CD)

Jari Likonen to CCFE (United Kingdom), 16–20 Mar 2014 (WP JET2)

Sixten Norrman to PMU-Garching (Germany), 17 Mar 2015 (WP PMI)

Karri Honkoila to PMU-Garching (Germany), 17 Mar 2015 (WP PMI)

Markus Airila to IPP.CR (Czech Republic), 23–27 Mar 2015 (WP CD)

Taina Kurki-Suonio to ITER IO (France), 24–27 Mar 2015 (International Collaborations)

Leena Aho-Mantila to ITER IO (France), 12–17 Apr 2015 (WP PMI)

Aaro Järvinen to ITER IO (France), 12–18 Apr 2015 (WP JET1)

Jari Likonen to CCFE (United Kingdom), 13–17 Apr 2015 (WP JET2)

Antti Hakola to CU (Slovakia), 19–22 Apr 2015 (WP PFC)

Leena Aho-Mantila to IPP (Germany), 22–13 May 2015 (WP DTT1)

Tuomas Tala to ITER IO (France), 4–7 May 2015 (International Collaborations)

Tuomas Koskela to PPPL, Princeton, NJ, USA, 4–22 May 2015 (International Collaborations)

Paula Sirén to Tampere, Finland, 25–26 May 2015 (WP EDU)

Kalle Heinola to IST (Portugal), 7–12 Jun 2015 (WP JET2)

Juuso Karhunen to DIFFER (Netherlands), 7–12 Jun 2015 (WP PFC)

Fredric Granberg to CCFE (United Kingdom), 8–10 Jun 2015 (WP MAT)

Paula Sirén to Cambridge, UK, 10–12 Jun 2015 (WP EDU)

Sami Kiviluoto to PMU-Garching (Germany), 10–16 Jun 2015 (WP PMI)

Sixten Norrman to PMU-Garching (Germany), 10–16 Jun 2015 (WP PMI)

Taina Kurki-Suonio to CEA (France), 16–19 Jun 2015 (Enabling Research)

Jari Likonen to CCFE (United Kingdom), 22 Jun–10 Jul 2015 (WP JET2)

Jari Varje to CCFE (United Kingdom), 29 Jun–24 Jul 2015 (WP JET1)

Paula Sirén to Cadarache, France, 30 Jun–3 Jul 2015 (WP EDU)

Sixten Norrman to PMU-Garching (Germany), 8–9 Jul 2015 (WP BOP)

Tuomas Tala to IPP (Germany), 13–16 Jul 2015 (WP MST1)

Aki Lahtinen to IPP (Germany), 20–21 Jul 2015 (WP MST1)

Antti Hakola to IPP (Germany), 20–24 Jul 2015 (WP MST1)

Simppa Äkäslompolo to IPP Greifswald (Germany), 31 Aug–12 Sep 2015 (WP S1)

Taina Kurki-Suonio to IAEA, Vienna, Austria, 6–8 Sep 2015 (International Collaborations)

Aki Lahtinen to IPP (Germany), 7–9 Sep 2015 (WP MST1)

Aki Lahtinen to IPP Garching (Germany), 7–9 Sep 2015 (WP PFC)

Antti Hakola to IPP (Germany), 7–11 Sep 2015 (WP MST1)

Antti Hakola to IPP (Germany), 13–18 Sep 2015 (WP PFC)

Jari Likonen to CCFE (United Kingdom), 14–18 Sep 2015 (WP JET2)

Jari Likonen to CCFE (United Kingdom), 8–16 Oct 2015 (WP JET2)

Paula Sirén to Knoxville, TN, USA, 11–16 Oct 2015 (WP EDU)

Antti Hakola to IPP (Germany), 12–15 Oct 2015 (WP MST1)

Paula Sirén to JET facility (United Kingdom), 19–30 Oct 2015 (WP JET1)

Mathias Groth to General Atomics, San Diego, California, USA, 19 Oct–28 Nov 2015 (International Collaborations)

Tuomas Tala to IPP (Germany), 20–22 Oct 2015 (International Collaborations)

Susan Leerink to IPP (Germany), 25–29 Oct 2015 (Enabling Research)

Tuomas Tala to IPP (Germany), 26–29 Oct 2015 (WP MST1)

Aaro Järvinen to JET facility (United Kingdom), 26 Oct–13 Nov 2015 (WP JET1)

Jaroslavs Uljanovs to JET facility (United Kingdom), 26 Oct–20 Nov 2015 (WP JET1)

Sami Kiviluoto to PMU-Garching (Germany), 27 Oct 2015 (WP PMI)

Sixten Norrman to PMU-Garching (Germany), 27 Oct 2015 (WP PMI)

Antti Hakola to IPP (Germany), 27 Oct–30 Oct 2015 (WP MST1)

Kalle Heinola to IST (Portugal), 1–6 Nov 2015 (WP JET2)

Fredric Granberg to IPP Garching (Germany), 2–4 Nov 2015 (WP MAT)

Andrea Sand to PMU-Garching (Germany), 3 Nov 2015 (PMU)

Antti Hakola to EPFL (Swiss Confederation), 3–6 Nov 2015 (WP MST1)

Antti Salmi to JET facility (United Kingdom), 4–10 Nov 2015 (WP JET1)

Tuomas Tala to JET facility (United Kingdom), 4–12 Nov 2015 (WP JET1)

Jari Likonen to CCFE (United Kingdom), 9–13 Nov 2015 (WP JET2)

Antti Hakola to IPP (Germany), 9–13 Nov 2015 (WP MST1)

Marko Santala to JET facility (United Kingdom), 9 Nov–11 Dec 2015 (WP JET1)

Markus Airila to IPP (Germany), 16–20 Nov 2015 (WP CD)

Antti Hakola to CCFE (United Kingdom), 22–27 Nov 2015 (WP PFC)

Antti Hakola to IPP (Germany), 30 Nov–11 Dec 2015 (WP MST1)

Jari Varje to PMU-Garching (Germany), 31 Nov–1 Dec 2015 (WP PMI)

Paula Sirén to JET facility (United Kingdom), 7–11 Dec 2015 (WP EDU)

Jari Likonen to CCFE (United Kingdom), 14–18 Dec 2015 (WP PFC)

Antti Hakola to EPFL (Swiss Confederation), 16–18 Dec 2015 (WP MST1)

Ming Li to CCFE (United Kingdom), 16–24 Dec 2015 (Engineering Grants)

Yongbo Wang to CCFE (United Kingdom), 16–24 Dec 2015 (Researcher Grants)

11.2 Conferences, seminars, workshops and meetings

Juuso Karhunen and Jari Likonen participated in the Estonian-Finnish-Latvian seminar on joint LIBS activities under EUROfusion WP PFC SP5.2, University of Tartu (Estonia), 14–15 Jan 2015.

45 participants in the Joint Working Session on Integrated Plasma-Wall Modelling, Tervaniemi (Finland), 3–6 Feb 2015. Local organizers were Markus Airila and Antti Hakola.

Tuomas Tala participated in the 9th EUROfusion General Assembly meeting, Garching (Germany), 16–17 Mar 2015.

Tuomas Tala participated in the F4E Governing Board meeting, Barcelona (Spain), 18–19 Mar 2015.

About 400 participants in the 49th Annual Meeting of the Finnish Physical Society (Physics Days 2015), Helsinki (Finland), 17–19 Mar 2015. Flyura Djurabekova was a member of the programme committee. Dr. Richard Pitts, ITER Organization, gave a keynote presentation on the ITER project.

Timo Määttä participated in F4E ILO Meeting, Marseille (France), 24 Mar 2015.

Jouni Mattila, Timo Määttä and Matti Paljakka participated in ITER Business forum, Marseille (France), 25–27 Mar 2015.

Juuso Karhunen participated in 1st EPS Conference on Plasma Diagnostics, Frascati (Italy), 14–17 Apr 2015.

Antti Hakola gave a colloquium presentation in Comenius University, Bratislava (Slovakia) on 21 Apr 2015.

Tuomas Tala participated in the 20th EU-US Transport Task Force Meeting, Salem, MA, USA, 28 April–1 May 2015.

Antti Hakola, Kalle Heinola, Aki Lahtinen and Jari Likonen participated in the 15th International Conference on Plasma-Facing Materials and Components for Fusion Applications, Aix-en-Provence, France, 18–22 May 2015.

55 participants in FinnFusion Annual Seminar 2015, Tampere (Finland), 25–26 May 2015.

Taina Kurki-Suonio gave an invited lecture in the Erice Summer School, 15th Course: “Plasma Heating and Current Drive for ITER Operation and DEMO Needs”, Elice, Italy, 24–31 May 2015.

Antti Hakola participated in the Northern Optics and Photonics 2015 conference, Lappeenranta (Finland), 1–4 June 2015.

Tuomas Tala participated in the F4E Governing Board meeting, Barcelona (Spain), 8–9 Jun 2015.

Jouni Mattila, Timo Määttä, Pertti Peussa and Mikko Siuko participated in F4E Remote Handling Workshop, Barcelona (Spain), 16–18 June 2015.

19 participants in EUROfusion FuseCOM Annual Meeting, Tampere, Finland, 16–18 June 2015.

Taina Kurki-Suonio and Konsta Särkimäki participated in the 3rd Runaway Electron Meeting (REM-2015), Pertuis, France, 17–19 Jun 2015.

Jouni Mattila and Liisa Aha participated in ITER RH workshop, Barcelona (Spain), 17–19 Jun 2015.

Aaro Järvinen, Paavo Niskala, Tuomas Tala and Antti Salmi participated in the 42nd EPS Conference on Plasma Physics, Lisbon (Portugal), 22–26 Jun 2015.

Taina Kurki-Suonio participated in the *Nuclear Fusion* Editorial Board meeting, Lisbon (Portugal), 23 Jun 2015.

Paavo Niskala participated in Workshop EFTSOMP, Lisbon (Portugal), 29–30 Jun 2015.

Markus Airila participated in the 10th EUROfusion General Assembly meeting, Warsaw (Poland), 1–2 Jul 2015.

Ronan Rochford and Jaro Uljanovs participated in 12th Carolus Magnus Summer School on Plasma and Fusion Energy Physics, Leuven (Belgium), 23 Aug–4 Sep 2015.

Ronan Rochford participated in 15th International Workshop on Plasma Edge Theory in Fusion Devices, Nara (Japan), 9–11 Sep 2015.

Ming Li and Yongbo Wang participated in ISFNT12, Korea, 14–18 Sep 2015.

Fredric Granberg participated in 7th N-Fame workshop, Getafe (Spain) 21–22 Sep 2015.

Timo Määttä participated in ITER-F4E-EFLO Meeting, Cadarache (France), 28 Sep 2015.

Timo Määttä participated in F4E ILO Meeting, Barcelona (Spain), 29 Sep 2015.

Tuomas Tala participated in the 11th EUROfusion General Assembly meeting, Budapest (Hungary), 30 Sep–1 Oct 2015.

Tuomas Tala participated in the F4E Governing Board meeting, Barcelona (Spain), 6 Oct 2015.

Fredric Granberg, Kai Nordlund, Jussi Polvi, Elnaz Safi and Andrea Sand participated in 17th International Conference on Fusion Reactor Materials, Aachen (Germany), 11–16 Oct 2015.

Fredric Granberg participated in Finlandssvenska fysik och kemidagarna, Helsinki (Finland), 13–15 Nov 2015.

Paavo Niskala participated in Fusenet PhD Event, Prague (Czech Republic), 15–18 Nov 2015.

Mathias Groth and Aaro Järvinen participated in the 57th Annual Meeting of the APS Division of Plasma Physics, Savannah, GA, USA, 16–20 Nov 2015.

Timo Määttä participated in F4E ILO Meeting, Barcelona (Spain), 25–26 Nov 2015.

Tuomas Tala participated in the F4E Governing Board meeting, Barcelona (Spain), 1–2 Dec 2015.

Fredric Granberg participated in Advances in materials & processing technologies, Madrid (Spain), 14–17 Dec 2015.

Tuomas Tala participated in the 12th EUROfusion General Assembly meeting, Milan (Italy), 17–18 Dec 2015.

11.3 Other visits

Juuso Karhunen participated in Experiment on SOL flow measurements in ASDEX Upgrade, IPP (Germany), 21–25 Sep 2015.

Juuso Karhunen participated in Analysis on experiment on SOL flow measurements in ASDEX Upgrade, IPP (Germany), 9–20 Nov 2015.

Antti Hakola visited Polytechnic University of Milan as a member of Final Examination Committee of PhD candidates, Milan (Italy), 14–16 Dec 2015.

11.4 Visitors

Dr. S. Pinches, ITER Organization, visited Aalto University on 8–9 January 2015 and acted as the opponent in the doctoral defence of Tuomas Koskela.

C. van Hille, C. Damiani, S. Esqué, P. Bates, E. Ruiz, A. Apollonatos from F4E, Barcelona, Spain and Mario Merola, Stefan Gicquel, Andrey Fedosov, Marcos Garcia-Martinez, Robert Arnoux from ITER Cadarache, France, and Jean-Michel Herbint, Christophe Wirtgen (EC film group) visited VTT (DTP2) on 26–27 February 2015.

G. Micciche, ENEA Brasimone, Italy and G. Mazzone, ENEA Frascati, Italy, visited VTT (DTP2) on 5 March 2015.

Dr. V. Yavorskij, University of Innsbruck, visited Aalto University on 5–6 March 2015 and acted as the opponent in the doctoral defence of Otto Asunta.

Artur Perevalov, Ioffe Institute, St. Petersburg, Russia, visited Aalto University on 3–15 May 2015.

Prof. D. Reiter, FZ Jülich, visited Aalto University on 28–29 May 2015 and acted as the opponent in the doctoral defence of Juho Miettunen.

Evgeniy Gusakov, Alexey Gurchenko and Mikhail Irzak, Ioffe Institute, St. Petersburg, Russia, visited Aalto University on 31 May–7 June 2015.

EUROfusion FuseCOM Annual Meeting delegates, 19 persons, visited VTT (DTP2) on 16 June 2015.

Artur Perevalov, Ioffe Institute, St. Petersburg, Russia, visited Aalto University on 19–24 July 2015.

A. Lasa, Oak Ridge National Laboratory, Tennessee, US, visited Aalto University, University of Helsinki, and VTT on 3–21 August 2015.

S. Zhongele and Yue Xiujiang from China Academy of Machinery Science and Technology, China, visited VTT (DTP2) on 19 August 2015.

A. Loving and T. Tremetnik from RACE, UK and G. Micciche, ENEA Brasimone, Italy and D. Marzullo, CREATE Italy, visited VTT (DTP2) on 26 August 2015.

EARTO delegates: G. Ganet, CEA, France, A. Erikson, FOI, Sweden, L. Emaldi, Tecnalia, Spain, H. Schwabach and A. Nowak, AIT, Austria, P. Bordages, Onera, France, A. van der Steen, TNO, Netherlands, visited VTT (DTP2) on 7 October 2015.

Dr. Peeter Paris from University of Tartu, Estonia, and Prof. Pavel Veis and Mr. Marek Pribula from Comenius University, Bratislava, Slovakia, visited VTT on 5–11 Oct 2015.

Klaus Meister, IPP Garching, visited VTT (DTP2) on 3 December 2015.

Dr. David Coster, IPP Garching, visited Aalto University on 3–4 December 2015 and acted as the opponent in the doctoral defence of Aaro Järvinen.

Evgeniy Gusakov, Alexey Gurchenko and Mikhail Irzak, Ioffe Institute, St. Petersburg, Russia, visited Aalto University on 13–20 December 2015.

Publications 2015

11.5 Publications

11.5.1 Refereed journal articles

1. D. Carralero, P. Manz, L. Aho-Mantila, G. Birkenmeier, M. Brix, M. Groth, H. W. Müller, U. Stroth, N. Vianello, E. Wolfrum, ASDEX Upgrade team, JET Contributors, and EUROfusion MST1 Team, Experimental validation of a filament transport model in turbulent magnetized plasmas, *Physical Review Letters* **115** (2015) 215002.
2. O. Asunta, J. Govenius, R. Budny, M. Gorelenkova, G. Tardini, T. Kurki-Suonio, A. Salmi, S. Sipilä, ASDEX Upgrade Team, the JET EFDA Contributors, Modelling neutral beams in fusion devices: Beamlet-based model for fast particle simulations, *Computer Physics Communications* **188** (2015) 33–46.
3. R. Wenninger, F. Arbeiter, J. Aubert, L. Aho-Mantila, R. Albanese, R. Ambrosino, C. Angioni, J. -F. Artaud, M. Bernert, E. Fable, A. Fasoli, G. Federici, J. Garcia, G. Giruzzi, F. Jenko, P. Maget, M. Mattei, F. Maviglia, E. Poli, G. Ramogida, C. Reux, M. Schneider, B. Sieglin, F. Villone, M. Wischmeier, H. Zohm, *Advances in the Physics Basis for the European DEMO Design*, *Nuclear Fusion* **55** (2015) 063003.
4. S. Brezinsek, A. Widdowson, M. Mayer, V. Philipps, P. Baron-Wiechec, J. W. Coenen, K. Heinola, A. Huber, J. Likonen, P. Petersson, M. Rubel, M. F. Stamp, D. Borodin, J. P. Coad, A. G. Carrasco, A. Kirschner, S. Krat, K. Krieger, B. Lipschultz, C. Linsmeier, G. F. Matthews, K. Schmid, JET contributors, Beryllium Migration in JET ITER-like Wall Plasmas, *Nuclear Fusion* **55** (2015) 063021.
5. A. Snicker, O. Asunta, H. Ylitie, T. Kurki-Suonio, M. Schneider, S. Pinches, Alpha particle driven current and torque in ITER baseline scenarios with 3D perturbations, *Nuclear Fusion* **55** (2015) 063023.
6. P. Niskala, T.P. Kiviniemi, S. Leerink, T. Korpilo, Gyrokinetic simulations of interplay between geodesic acoustic modes and trapped electron mode turbulence, *Nuclear Fusion* **55** (2015) 073012.
7. S. Äkäslompolo, T. Kurki-Suonio, O. Asunta, M. Cavinato, M. Gagliardi, E. Hirvijoki, G. Saibene, S. Sipilä, A. Snicker, K. Särkimäki, J. Varje, ITER fast ion confinement in the presence of the European test blanket module, *Nuclear Fusion* **55** (2015) 093010.
8. J. Tian, J. Yang, S. Kong, J. Xue, Y. Wang, and K. Nordlund, Capacity of graphite's layered structure to suppress the sputtering yield: a molecular dynamics study, *Applied Surface Science* **337** (2015) 6.
9. C. Giroud, S. Jachmich, P. Jacquet, A. Järvinen, E. Lerche, F. Rimini, L. Aho-Mantila, N. Aiba, I. Balboa, P. Belo, C. Angioni, M. Beurskens, S. Brezinsek, F.J. Casson, I. Coffey, G. Cunningham, E. Delabie, S. Devaux, P. Drewelow, L. Frassinetti, A. Figueiredo, A. Huber, J. Hillesheim, L. Garzotti, M. Goniche, M. Groth, Hyun-Tae Kim, M. Leyland, P. Lomas, G. Maddison, S. Marsen, G. Matthews, A. Meigs, S. Menmuir, T. Puetterich, G. van Rooij, S. Saarelma, M. Stamp, H. Urano, A. Webster and the JET EFDA contributors, Progress at JET in Integrating ITER-Relevant Core and Edge Plasmas within the Constraints of an ITER-Like Wall, *Plasma Physics and Controlled Fusion* **57** (2015) 035004.
10. T. Koskela, M. Romanelli, P. Belo, O. Asunta, S. Sipilä, M. O. Mullane, L. Giacomelli, S. Conroy, P. Mantica, P. Valisa, C. Angioni, T. Kurki-Suonio, Effect of tungsten off-

- axis accumulation on Neutral Beam Deposition in JET rotating plasmas, *Plasma Physics and Controlled Fusion* **57** (2015) 045001.
11. P. Sirén, T. Tala, G. Corrigan, J. Garcia, T. Koskela, F. Köchl, X. Litaudon, A. Salmi, the JET contributors and the EU-ITM ITER Scenario Modelling Group, Understanding of the fundamental differences in JET and JT-60U AT discharges, *Plasma Physics and Controlled Fusion* **57** (2015) 075015.
 12. A. Chankin, G. Corrigan, M. Groth, P. C. Stangeby, Influence of the $E \times B$ Drift in High Recycling Divertors on Target Asymmetries, *Plasma Physics and Controlled Fusion* **57** (2015) 095002.
 13. J. Byggmästar, F. Granberg, A. Kuronen, K. Nordlund, and K. O. E. Henriksson, Tensile testing of Fe and FeCr nanowires using molecular dynamics simulations, *Journal of applied physics* **117** (2015) 014313.
 14. P. Kuopanportti, E. Hayward, C.-C. Fu, A. Kuronen, and K. Nordlund, Interatomic Fe–H potential for irradiation and embrittlement simulations, *Computational Materials Science* **111** (2015) 525.
 15. X. Yi, A. E. Sand, D. R. Mason, M. A. Kirk, S. G. Roberts, K. Nordlund, and S. L. Dudarev, Direct observation of size scaling and elastic interaction between nano-scale defects in collision cascades, *Europhysics Letters* **110** (2015) 036001.
 16. A.D. Gurchenko, E.Z. Gusev, P. Niskala, A.B. Altukhov, L.A. Esipov, T.P. Kiviniemi, D.V. Kouprienko, M.Yu. Kantor, S.I. Lashkul, S. Leerink, A.A. Perevalov and T.Korpilo, Turbulence and anomalous tokamak transport control by Geodesic Acoustic Mode, *Europhysics Letters* **110** (2015) 055001.
 17. A. E. Sand and K. Nordlund, On the lower energy limit of electronic stopping in simulated collision cascades in Ni, Pd and Pt, *Journal of Nuclear Materials* **456** (2015) 99.
 18. A. Sand, K. Nordlund, On the lower energy limit of electronic stopping in simulated collision cascades in Ni, Pd and Pt, *Journal of Nuclear Materials* **456** (2015) 99–105.
 19. F. Granberg, D. Terentyev, K. Nordlund, Interaction of dislocation with carbides in BCC Fe studied by molecular dynamics, *Journal of Nuclear Materials* **460** (2015) 23–29.
 20. A. Scarabosio, T. Eich, F. Hoppe, I. Paradela, B. Sieglin, M. Rack, M. Groth, M. Wischmeier, G. Arnoux, I. Balboa, S. Marsen, the ASDEX Upgrade Team and JET-EFDA contributors, Scaling of the divertor power spreading (S-factor) in open and closed divertor operation in JET and ASDEX Upgrade, *Journal of Nuclear Materials* **463** (2015) 49–54.
 21. A. Kirschner, D. Matveev, D. Borodin, M. Airila, S. Brezinsek, M. Groth, S. Wiesen, A. Widdowson, J. Beal, H.G. Esser, J. Likonen, N. Bekris and JET-EFDA Contributors, Modelling of the material transport and layer formation in the divertor of JET: comparison of ITER-like wall with full carbon wall conditions, *Journal of Nuclear Materials* **463** (2015) 116–122.
 22. D. Carralero, H.W. Müller, M. Groth, M. Komm, J. Adamek, G. Birkenmeier, M. Brix, F. Janky, P. Hacek, S. Marsen, C. Silva, U. Stroth, M. Wischmeier, E. Wolftrum, ASDEX Upgrade Team, COMPASS Team and JET-EFDA Contributors, Implications of high density operation on SOL transport A multimachine investigation, *Journal of Nuclear Materials* **463** (2015) 123–127.
 23. F. Reimold, M. Wischmeier, L. Aho-Mantila, M. Bernert, X. Bonnin, D. Coster, A. Kallenbach, G. Meisl, S. Potzel, D. Reiter and the ASDEX Upgrade Team,

- Experimental Studies and Modeling of Complete H-Mode Divertor Detachment in ASDEX Upgrade, *Journal of Nuclear Materials* **463** (2015) 128–134.
24. A. Järvinen, M. Groth, M. Airila, P. Belo, M. Beurskens, S. Brezinsek, G. Corrigan, S. Devaux, P. Drewelow, T. Eich, C. Giroud, D. Harting, A. Huber, S. Jachmich, K. Lawson, B. Lipschultz, G. Maddison, C. Maggi, T. Makkonen, C. Marchetto, S. Marsen, G.F. Matthews, A.G. Meigs, D. Moulton, M.F. Stamp, S. Wiesen, M. Wischmeier and EFDA-JET collaborators, Interpretation of radiative divertor studies with impurity seeding in type-I ELMy H-mode plasmas in JET-ILW using EDGE2D/EIRENE, *Journal of Nuclear Materials* **463** (2015) 135–142.
 25. A. Hakola, S. Koivuranta, J. Likonen, A. Herrmann, H. Maier, M. Mayer, R. Neu, V. Rohde, and the ASDEX Upgrade Team, Erosion of tungsten and steel in the main chamber of ASDEX Upgrade, *Journal of Nuclear Materials* **463** (2015) 162–165.
 26. J.H. Yu, M. J. Baldwin, R.P. Doerner, T. Dittmar, A. Hakola, T. Höschel, J. Likonen, D. Nishijima, and H.H. Toudeshki, Transient heating effects on tungsten: ablation of Be layers and enhanced fuzz growth, *Journal of Nuclear Materials* **463** (2015) 299–302.
 27. I. Đuran, K. Ješko, V. Fuchs, M. Groth, C. Guillemaut, J.P. Gunn, J. Horacek, R.A. Pitts, D. Tskhakaya, the JET-EFDA Contributors, Assessment of the effect of parallel temperature gradients in the JET SOL on Te measured by divertor target Langmuir probes, *Journal of Nuclear Materials* **463** (2015) 432–435.
 28. A. Huber, S. Brezinsek, G. Sergienko, M. Groth, P.C. de Vries, L. Aho-Mantila, G. Arnoux, M. Bernert, M.N.A. Beurskens, G. Calabro, M. Clever, H.G. Esser, C. Guillemaut, S. Jachmich, A. Järvinen, Ch. Linsmeier, G.F. Matthews, A.G. Meigs, Ph. Mertens, V. Philipps, M. Stamp, et al., Density limit of H-mode plasmas on JET-ILW, *Journal of Nuclear Materials* **463** (2015) 445–449.
 29. P. Tamain, E. Joffrin, H. Bufferand, A. Järvinen, S. Brezinsek, G. Ciraolo, E. Delabie, L. Frassinetti, C. Giroud, M. Groth, B. Lipschultz, P. Lomas, S. Marsen, S. Menmuir, M. Oberkofler, M. Stamp, S. Wiesen, JET EFDA contributors, Investigation of the influence of divertor recycling on global plasma confinement in JET ITER-like wall, *Journal of Nuclear Materials* **463** (2015) 450–454.
 30. J. Miettunen, M. Airila, M. Groth, V. Lindholm, T. Makkonen, S. Äkäslompolo, ASDEX Upgrade Team, Influence of toroidal field ripple and resonant magnetic perturbations on global 13C transport in ASDEX Upgrade, *Journal of Nuclear Materials* **463** (2015) 459–462.
 31. M. Groth, S. Brezinsek, P. Belo, G. Calabro, G. Corrigan, M. Brix, M. Clever, J.W. Coenen, S. Devaux, P. Drewelow, T. Eich, D. Harting, A. Huber, S. Jachmich, A. Järvinen, U. Kruezi, K.D. Lawson, M. Lehnen, C.F. Maggi, C. Marchetto, S. Marsen, F. Maviglia, A.G. Meigs, G. Sergienko, B. Sieglin, C. Silva, M.F. Stamp, S. Wiesen, and the EFDA-JET contributors, Divertor plasma conditions and neutral dynamics in semi-horizontal and vertical divertor configurations in JET-ILW low confinement plasmas, *Journal of Nuclear Materials* **463** (2015) 471–476.
 32. D. Harting, S. Wiesen, M. Groth, S. Brezinsek, G. Corrigan, G. Arnoux, P. Boerner, S. Devaux, J. Flanagan, A. Järvinen, S. Marsen, D. Reiter, Intra-ELM phase modelling of a JET ITER-like wall H-mode discharge with EDGE2D-EIRENE, *Journal of Nuclear Materials* **463** (2015) 493–497.
 33. A.G. McLean, A.W. Leonard, M.A. Makowski, M. Groth, S.L. Allen, J.A. Boedo, B.D. Bray, A.R. Briesemeister, T.N. Carlstrom, D. Eldon, M.E. Fenstermacher, D.N. Hill, C.J. Lasnier, C. Liu, T.H. Osborne, T.W. Petrie, V.A. Soukhanovskii, P.C. Stangeby,

- C. Tsui, E.A. Unterberge, J.G. Watkins, Electron pressure balance in the SOL through the transition to detachment, *Journal of Nuclear Materials* **463** (2015) 533–536.
34. L. Aho-Mantila, X. Bonnin, D. Coster, C. Lowry, M. Wischmeier, S. Brezinsek, G. Federici, ASDEX Upgrade Team, the JET-EFDA Contributors, Model-Based Radiation Scalings for the ITER-like Divertors of JET and ASDEX Upgrade, *Journal of Nuclear Materials* **463** (2015) 546–550.
 35. K.D. Lawson, M. Groth, P. Belo, S. Brezinsek, G. Corrigan, A. Czarnecka, E. Delabie, P. Drewelow, D. Harting, I. Książek, C.F. Maggi, C. Marchetto, A.G. Meigs, S. Menmuir, M.F. Stamp, S. Wiesen, JET-EFDA Contributors, Improved EDGE2D-EIRENE simulations of JET ITER-like wall L-mode discharges utilising poloidal VUV/visible spectral emission profiles, *Journal of Nuclear Materials* **463** (2015) 582–585.
 36. V. Parail, G. Corrigan, P. Da Silva Aresta Belo, E. De La Luna, D. Harting, F. Koechl, T. Koskela, A. Meigs, E. Militello-Asp, M. Romanelli, M. Tsalas and JET-EFDA contributors, Coupled core-SOL modelling of W accumulation in JET H-mode plasmas with ITER-like wall, *Journal of Nuclear Materials* **463** (2015) 611–614.
 37. D. Tskhakaya, M. Groth and JET EFDA Contributors, Modelling of tungsten re-deposition coefficient, *Journal of Nuclear Materials* **463** (2015) 624–628.
 38. E. Lerche, M. Goniche, P. Jacquet, D. Van Eester, V. Bobkov, L. Colas, A. Czarnecka, S. Brezinsek, M. Brix, K. Crombe, M. Graham, M. Groth, I. Monakhov, T. Mathurin, G. Matthews, L. Meneses, C. Noble, V. Petrzilka, F. Rimini, A. Shaw, JET-EFDA Contributors, Impact of gas injection on ICRF coupling and SOL parameters in JET-ILW H-mode plasmas, *Journal of Nuclear Materials* **463** (2015) 634–639.
 39. G. Meisl, K. Schmid, M. Oberkofler, K. Krieger, S.W. Lisgo, L. Aho-Mantila, F. Reimold, ASDEX Upgrade Team, Nitrogen retention in ASDEX Upgrade, *Journal of Nuclear Materials* **463** (2015) 668–671.
 40. I. Bykov, H. Bergsäter, G. Possnert, K. Heinola, J. Miettunen, M. Groth, P. Petersson, A. Widdowson, J. Likonen, JET EFDA contributors, Materials migration in JET with ITER-like wall traced with a ^{10}Be isotopic marker, *Journal of Nuclear Materials* **463** (2015) 773–776.
 41. R.P. Doerner, I. Jepu, D. Nishijima, E. Safi, L. Bukonte, A. Lasa, K. Nordlund, T. Schwarz-Selinger, The relationship between gross and net erosion of beryllium at elevated temperature, *Journal of Nuclear Materials* **463** (2015) 777–780.
 42. H.G. Esser, V. Philipps, M. Freisinger, A. Widdowson, K. Heinola, A. Kirschner, P. Petersson, P. Wienhold, S. Brezinsek, A. Huber, G.F. Matthews, M. Rubel, G. Sergienko, and JET-EFDA contributors, Material deposition on inner divertor quartz-micro balances during ITER-like wall operation in JET, *Journal of Nuclear Materials* **463** (2015) 796–799.
 43. M.I. Airila, A. Järvinen, M. Groth, P. Belo, S. Wiesen, S. Brezinsek, K. Lawson, D. Borodin, A. Kirschner, J.P. Coad, K. Heinola, J. Likonen, M. Rubel, A. Widdowson and JET-EFDA Contributors, Preliminary Monte Carlo simulation of beryllium migration during JET ITER-like wall divertor operation, *Journal of Nuclear Materials* **463** (2015) 800–804.
 44. E. Safi, C. Björkas, A. Lasa, K. Nordlund, I. Sukuba, M. Probst, Atomistic simulations of the effect of reactor-relevant parameters on Be sputtering, *Journal of Nuclear Materials* **463** (2015) 805–809.

45. P. Petersson, M. Rubel, H.G. Esser, J. Likonen, S. Koivuranta, A. Widdowson, JET-EFDA Contributors, Co-deposited layers in the divertor region of JET-ILW, *Journal of Nuclear Materials* **463** (2015) 814–817.
46. J. Beal, A. Widdowson, K. Heinola, A. Baron-Wiechec, K. J. Gibson, J. P. Coad, E. Alves, B. Lipschultz, A. Kirschner, G. F. Matthews, Analysis of rotating collectors from the private region of JET with carbon wall and metallic ITER-like wall, *Journal of Nuclear Materials* **463** (2015) 818–821.
47. M. Sertoli, J.C. Flannegan, M. Bacharis, O. Kardaun, A. Jarvinen, G.F. Matthews, S. Brezinsek, D. Harting, A. Cackett, E. Hodille, I.H. Coffey, T. Pütterich, JET-EFDA Contributors, Impact of W events and dust on JET-ILW operation, *Journal of Nuclear Materials* **463** (2015) 837–841.
48. J. Likonen, J.P. Coad, A. Hakola, J. Karhunen, S. Koivuranta, R. Pitts, A.M. Widdowson and JET-EFDA contributors, Measurement of dust conversion factor for the JET carbon divertor phases, *Journal of Nuclear Materials* **463** (2015) 842–846.
49. D. Moulton, Y. Marandet, P. Tamain, Ph. Ghendrih, M. Groth, SOL turbulence and the interpretation of BES and GPI experiments, *Journal of Nuclear Materials* **463** (2015) 893–896.
50. K. Piip, G. De Temmerman, H.J. van der Meiden, A. Lissovski, J. Karhunen, M. Aints, A. Hakola, P. Paris, M. Laan, J. Likonen, I. Jögi, J. Kozlova, H. Mändar, LIBS analysis of tungsten coatings exposed to Magnum PSI ELM-like plasma, *Journal of Nuclear Materials* **463** (2015) 919–922.
51. A. Lissovski, K. Piip, L. Hämarik, M. Aints, M. Laan, P. Paris, A. Hakola, J. Karhunen, LIBS for tungsten diagnostics in vacuum: Selection of analytes, *Journal of Nuclear Materials* **463** (2015) 923–926.
52. J. Karhunen, A. Hakola, J. Likonen, A. Lissovski, M. Laan, P. Paris and JET EFDA Contributors, Applicability of LIBS for in situ monitoring of deposition and retention on the ITER-like wall of JET – Comparison to SIMS, *Journal of Nuclear Materials* **463** (2015) 931–935.
53. H. Bergsäter, I. Bykov, P. Petersson, G. Possnert, J. Likonen, S. Koivuranta, J.P. Coad, W. Van Renterghem, I. Uytendhouwen, A.M. Widdowson, JET EFDA Contributors, Microscopically nonuniform deposition and deuterium retention in the divertor in JET with ITER-like wall, *Journal of Nuclear Materials* **463** (2015) 956–960.
54. K. Heinola, A. Widdowson, J. Likonen, E. Alves, A. Baron-Wiechec, N. Barradas, S. Brezinsek, N. Catarino, P. Coad, S. Koivuranta, G.F. Matthews, M. Mayer, P. Petersson, JET-EFDA Contributors, Fuel Retention in JET ITER-Like Wall from Post-Mortem Analysis, *Journal of Nuclear Materials* **463** (2015) 961–965.
55. Y. Hatano, A. Widdowson, N. Bekris, C. Ayres, A. Baron-Wiechec, J. Likonen, S. Koivuranta, J. Likonen, K. Yumizuru, JET-EFDA contributors, 2D tritium distribution on tungsten tiles used in JET ITER-like wall project, *Journal of Nuclear Materials* **463** (2015) 966–969.
56. S. Äkäslompolo, T. Kurki-Suonio, G. Tardini, G. Bonheure, the ASDEX Upgrade Team, Reverse ASCOT simulation of fusion product activation probe experiment in ASDEX Upgrade tokamak, *Journal of Instrumentation* **10** (2015) P10012.
57. P. Alho and J. Mattila, Service-oriented approach to fault tolerance in cyber-physical systems, *Journal of Systems & Software* **105** (2015) 1–17.
58. A. Hakola, J. Likonen, J. Karhunen, J. T. Korhonen, M. Aints, M. Laan, P. Paris, J. Kolehmainen, M. Koskinen, and S. Tervakangas, Feasibility of arc-discharge and

- plasma-sputtering methods in cleaning plasma-facing and diagnostics components of fusion reactors, *Fusion Engineering and Design* **96–97** (2015) 101–106.
59. S Äkäslompolo, O Asunta, T Bergmans, M Gagliardi, J Galabert, E Hirvijoki, T Kurki-Suonio, S Sipilä, A Snicker, K Särkimäki, Calculating the 3D magnetic field of ITER for European TBM studies, *Fusion Engineering and Design* **98–99** (2015) 1039–1043.
 60. P. Paris, K. Piip, A. Hakola, M. Laan, M. Aints, S. Koivuranta, J. Likonen, A. Lissovski, M. Mayer, R. Neu, V. Rohde, K. Sugiyama, the ASDEX Upgrade Team, Development of Laser Induced Breakdown Spectroscopy for studying erosion, deposition, and fuel retention in ASDEX Upgrade, *Fusion Engineering and Design* **98–99** (2015) 1349–1352.
 61. M. Li, H. Wu, H. Handroos, G. Yang, Y. Wang, Software protocol design: Communication and control in a multi-task robot machine for ITER vacuum vessel assembly and maintenance, *Fusion Engineering and Design* **98–99** (2015) 1532–1537.
 62. T. Makkonen, M.I. Airila and T. Kurki-Suonio, Generating equally weighted test particles from the one-way flux of a drifting Maxwellian, *Physica Scripta* **90** (2015) 095029.
 63. F. Granberg, D. Terentyev, K. Nordlund, Molecula dynamics investigation of the interaction of dislocations with carbides in BCC Fe, *Nuclear Instruments and Methods in Physics Section B* **352** (2015) 77–80.
 64. E. Hirvijoki, T. Kurki-Suonio, S. Äkäslompolo, J. Varje, T. Koskela, J. Miettunen, Monte Carlo method and High Performance Computing for solving Fokker-Planck equation of minority plasma particles, *Journal of Plasma Physics* **81** (2015) 435810301.
 65. J. Karhunen, M. Groth, P. Heliste, T. Makkonen, A. Hakola, E. Viezzer, T. Pütterich and the ASDEX Upgrade Team, Nitrogen as a spectroscopic tracer for measuring plasma flows in the high-field side SOL of ASDEX Upgrade, *Proceedings of Science (EPCD 2015)* 038.
 66. C. Stan-Sion, N. Bekris, G. Kizane, M. Enachescu, J. Likonen, M. Halitovs, A. Petre and JET contributors, Tritium retention measurements by accelerator mass spectrometry and full combustion of W-coated and uncoated CFC tiles from the JET divertor, *Nuclear Fusion*, accepted.
 67. G. Meisl, K. Schmid, M. Oberkofler, K. Krieger, S. Lisgo, L. Aho-Mantila, F. Reimold, T. Lunt, ASDEX Upgrade Team, Experimental analysis and WallDYN simulations of the global nitrogen migration in ASDEX Upgrade L-mode discharges, *Nuclear Fusion*, accepted.
 68. J. Varje, O. Asunta, M. Cavinato, M. Gagliardi, E. Hirvijoki, T. Koskela, T. Kurki-Suonio, Y. Liu, V. Parail, G. Saibene, S. Sipilä, A. Snicker, K. Särkimäki, Simppa Äkäslompolo, Effect of plasma response on the fast ion losses due to ELM control coils in ITER, *Nuclear Fusion*, accepted.
 69. A. Gurchenko, E. Gusakov, P. Niskala, A. Altukhov, L. Esipov, T. Kiviniemi, T. Korpilo, D. Kouprienko, S. Lashkul, S. Leerink, A. Perevalov, M. Irzak, The isotope effect in turbulent transport control by GAMs. Observation and gyrokinetic modeling, *Plasma Physics and Controlled Fusion*, accepted.
 70. E. Feldbach, E. Töldsepp, M. Kirm, A. Lushchik, K. Mizohata and J. Räisänen, Radiation resistance diagnostics of wide-gap optical materials, *Optical Materials*, accepted.

71. M.I. Airila, A. Järvinen, M. Groth, P. Belo, S. Wiesen, S. Brezinsek, K. Lawson, D. Borodin, A. Kirschner, J.P. Coad, K. Heinola, J. Likonen, M. Rubel, A. Widdowson and JET-EFDA Contributors, Preliminary Monte Carlo simulation of beryllium migration during JET ITER-like wall divertor operation, *Journal of Nuclear Materials*, accepted.
72. Sand, A. E., Dequeker, J., Becquart, C. S., Domain, C. & Nordlund, K, Non-equilibrium properties of interatomic potentials in cascade simulations in tungsten, *Journal of Nuclear Materials*, accepted.
73. Jing Wu, Huapeng Wu, Yuntao Song, Ming Li, Yang Yang, Daniel A.M. Alcina, Open software architecture for east articulated maintenance arm, *Fusion Engineering and Design*, accepted.
74. Jing Wu, Huapeng Wu, Yuntao Song, Yong Cheng, Wenglong Zhao, Yongbo Wang, Genetic algorithm trajectory plan optimization for EAMA: EAST Articulated Maintenance Arm, *Fusion Engineering and Design*, accepted.
75. A. De Backer, A. Sand, C.J. Ortiz, C. Domain, P. Olsson, E. Berthod, C.S. Becquart, Primary damage in tungsten using the binary collision approximation, molecular dynamic simulations and the density functional theory, *Physica Scripta*, accepted.
76. H. Bergsäter, I. Bykov, P. Petersson, G. Possnert, J. Likonen, S. Koivuranta, J. P. Coad, A. M. Widdowson and the JET EFDA contributors, Microstructure and inhomogenous fuel trapping at divertor surfaces in JET, *Nuclear Instruments and Methods in Physics Research Section B*, accepted.
77. T. Korpilo, T.P. Kiviniemi, S. Leerink, P. Niskala, and R. Rochford, Gyrokinetic simulations of the tokamak plasma edge in circular limiter configuration, *Contributions to Plasma Physics*, accepted.
78. G. Valles, I. Martin-Bragado, K. Nordlund, A. Lasa, C. Bjorkas, E. Safi, J.M. Perlado, and A. Rivera, Temperature dependence of underdense nanostructure formation in tungsten under helium irradiation, *Physical Review Letters*, submitted.
79. T. Korpilo, A.D. Gurchenko, E.Z. Gusakov, J.A. Heikkinen, S.J. Janhunen, T.P. Kiviniemi, S. Leerink, P. Niskala, A.A. Perevalov, Gyrokinetic full-torus simulations of ohmic tokamak plasmas in circular limiter configuration, *Computer Physics Communications*, submitted.
80. T.P. Kiviniemi, U. Sauerwein, The effects of spatial sampling on random noise for gyrokinetic PIC simulations in real space, *Computer Physics Communications*, submitted.
81. J. Marian, C. S. Becquart, C. Domain, S.L. Dudarev, M.R. Gilbert, R.J. Kurtz, D.R. Mason, K. Nordlund, A.E. Sand, L.L. Snead, T. Suzudo, and B.D. Wirth, Recent advances in computational materials modeling of tungsten as plasma-facing material for fusion energy applications, *Nuclear Fusion*, submitted.
82. M.N.A. Beurskens, M.G. Dunne, L. Frassinetti, M. Bernert, M. Cavedon, R. Fischer, A. Järvinen, A. Kallenbach, F.M. Laggner, R.M. McDermott, G. Tardini, E. Viezzer, E. Wolfrum, the ASDEX Upgrade Team, The role of carbon on the H-mode confinement in ASDEX Upgrade with a metal wall, *Nuclear Fusion*, submitted.
83. R. J. Buttery, S. Gerhardt, A. Isayama, R.J. La Haye, E.J. Strait, D. Chandra, S. Coda, J. De Grassie, P. Gohil, M. Gryaznevich, C. Holcomb, D. F. Howell, G. Jackson, M. Maraschek, A. Polevoi, H. Reimerdes, D. Raju, A. Sen, T. Tala, the JET-EFDA contributors, the DIII-D, JT-60 and NSTX teams, Cross-Machine Scaling of Neoclassical Tearing Modes Thresholds with Rotation, *Nuclear Fusion*, submitted.

84. J. Polvi, K. Heinola, and K. Nordlund, An interatomic potential for W-N interactions, *Journal of Physics: Condensed Matter*, submitted.
85. T. Makkonen, M.I. Airila, S. Brezinsek, M. Groth, A. Järvinen and JET EFDA Contributors, Combined ERO, DIVIMP, and EDGE2D-EIRENE simulations of material migration in ELMy H-mode JET plasmas, *Plasma Physics and Controlled Fusion*, submitted.
86. F. Reimold, M. Wischmeier, M. Bernert, S. Potzel, D. Coster, X. Bonnin, D. Reiter, G. Meisl, A. Kallenbach, L. Aho-Mantila, U. Stroth, the ASDEX Upgrade Team, Experimental Studies and Modeling of Complete H-Mode Divertor Detachment in ASDEX Upgrade, *Journal of Nuclear Materials*, submitted.
87. A. Hakola, J. Karhunen, M. Groth, A. Herrmann, K. Krieger, T. Kurki-Suonio, G. Meisl, M. Oberkofler, R. L. Neu, S. Potzel, V. Rohde, the ASDEX Upgrade Team, Gross and net erosion of tungsten in the outer strike-point of ASDEX Upgrade, *Physica Scripta*, submitted.
88. A. Widdowson, A. Baron-Wiechec, P. Batistoni, E. Belonohy, J.P. Coad, P. Dinca, D. Flammini, F. Fox, K. Heinola, I. Jepu, J. Likonen, S. Lilley, C.P. Lungu, G.F. Matthews, J. Naish, O. Pompilian, C. Porosnicu, M. Rubel, R. Villari and JET Contributors, Experience of handling beryllium, tritium and activated components from JET ITER like wall, *Physica Scripta*, submitted.
89. C. Ruset, E. Grigore, C. Luculescu, I. Tiseanu, J. Likonen, M. Mayer, M. Rubel G. F. Matthews, the JET contributors, Investigation on the erosion/deposition processes in the ITER-like Wall divertor at JET using Glow Discharge Optical Emission Spectrometry technique, *Physica Scripta*, submitted.
90. C.C. Klepper, D. Borodin, M. Groth, M. Airila, L. Colas, P. Jacquet, A. Kirschner, A. Lasa, and the JET Contributors, Estimates of RF-Induced Erosion at Antenna-Connected Beryllium Plasma-Facing Components in JET, *Physica Scripta*, submitted.
91. H. Bergsåker, I. Bykov, Y. Zhou, P. Petersson, G. Possnert, J. Likonen, J. Pettersson, S. Koivuranta, A.M. Widdowson and JET contributors, Deep deuterium retention and Be/W mixing at tungsten coated surfaces in the JET divertor, *Physica Scripta*, submitted.
92. J. Likonen, K. Heinola, A. De Backer, S. Koivuranta, A Hakola, C. F. Ayres, A. Baron-Wiechec, P. Coad, G. F. Matthews, M. Mayer, A. Widdowson, the JET Contributors, Deuterium trapping and release in JET ITER-Like Wall divertor tiles, *Physica Scripta*, submitted.
93. K. Heinola, A. Widdowson, J. Likonen, E. Alves, A. Baron-Wiechec, N. Barradas, S. Brezinsek, N. Catarino, P. Coad, S. Koivuranta, S. Krat, G.F. Matthews, M. Mayer, P. Petersson and JET Contributors, Long-term fuel retention in JET ITER-like wall, *Physica Scripta*, submitted.
94. L. Moser, L. Marot, R. Steiner, M. Newman, A. Widdowson, D. Ivanova, J. Likonen, P. Petersson, G. Pintsuk, M. Rubel, E. Meyer and JET Contributors, Plasma cleaning of beryllium coated mirrors, *Physica Scripta*, submitted.
95. M. Mayer, S. Krat, W. Van Renterghem, A. Baron-Wiechec, S. Brezinsek, I. Bykov, P. Coad, Y. Gasparyan, K. Heinola, J. Likonen, A. Pisarev, C. Ruset, G. de Saint-Aubin, A. Widdowson, the JET Contributors, Erosion and deposition in the JET divertor during the first ILW campaign, *Physica Scripta*, submitted.
96. M. Oberkofler, G. Meisl, A. Hakola, A. Drenik, D. Alegre, S. Brezinsek, R. Craven, T. Dittmar, T. Keenan, S. G. Romanelli, R. Smith, D. Douai, A. Herrmann, K. Krieger, U. Kruezi, G. Liang, C. Linsmeier, M. Mozetic, V. Rohde, the ASDEX Upgrade team, the

- EUROfusion MST Team, JET Contributors, Nitrogen retention mechanisms in tokamaks with Be and W plasma-facing surfaces, *Physica Scripta*, submitted.
97. S. Wiesen, M. Groth, S. Brezinsek, M. Wischmeier and JET contributors, Modelling of plasma-edge and plasma-wall interaction physics at JET with the metallic first-wall, *Physica Scripta*, submitted.
 98. Y. Hatano, K. Yumizuru, J. Likonen, S. Koivuranta, J. Ikonen and JET Contributors, Tritium distributions on tungsten and carbon tiles used in the JET divertor, *Physica Scripta*, submitted.
 99. M. Rubel, P. Petersson, E. Alves, S. Brezinsek, J. P. Coad, K. Heinola, M. Mayer, A. Widdowson, the JET Contributors, The Role and Application of Ion Beam Analysis for Studies of Plasma-Facing Components in Controlled Fusion Devices, *Nuclear Instruments and Methods in Physics Research B*, submitted.
 100. D. Borodin, S. Brezinsek, I. Borodkina, J. Romazanov, D. Matveev, A. Kirschner, A. Lasa, K. Nordlund, C. Björkas, M. Airila, J. Miettunen, M. Groth, M. Firdaouss, and JET Contributors, Improved ERO Modelling for Spectroscopy of physically and chemically assisted eroded Beryllium from the JET-ILW, *Nuclear Materials and Energy*, submitted.
 101. E. Safi, J. Polvi, A. Lasa, and K. Nordlund, Atomistic simulations of deuterium irradiation on iron-based alloys in future fusion reactors, *Nuclear Materials and Energy*, submitted.
 102. F. Granberg and K. Nordlund, Effect of obstacle nanostructure on the movement of edge dislocations in BCC Fe, *Nuclear Materials and Energy*, submitted.

11.5.2 Conference presentations

103. F. Granberg, D. Terentyev and K. Nordlund, Effect of structure of nanosized carbides on dislocation movement in bcc Fe: an atomistic study, *Physics Days 2015 – the 49th Annual Meeting of the Finnish Physical Society*, Helsinki, Finland, 17–19 March 2015.
104. J. Karhunen, A. Hakola, J. Likonen, A. Lissovski, M. Laan, P. Paris, C. Porosnicu, C.P. Lungu and the JET EFDA Contributors, Determining the composition of deposited layers in fusion reactors by laser-induced breakdown spectroscopy, *Physics Days 2015 – the 49th Annual Meeting of the Finnish Physical Society*, Helsinki, Finland, 17–19 March 2015.
105. J. Kontula, J. Miettunen, M.I. Airila, M. Groth, V. Lindholm, T. Makkonen, S. Äkäslompolo and the ASDEX Upgrade Team, ASCOT simulations of global ^{13}C transport in ASDEX Upgrade in the presence of resonant magnetic perturbations, *Physics Days 2015 – the 49th Annual Meeting of the Finnish Physical Society*, Helsinki, Finland, 17–19 March 2015.
106. P. Heliste, T. Makkonen, J. Karhunen, M. Groth, Modelling impurity flows in the tokamak scrape-off layer with synthetic Doppler spectroscopy, *Physics Days 2015 – the 49th Annual Meeting of the Finnish Physical Society*, Helsinki, Finland, 17–19 March 2015.
107. T. Korpilo, T. Kiviniemi, S. Leerink, P. Niskala, R. Rochford, First-principles modeling of FT-2 tokamak plasmas via ELMFIRE application, *Physics Days 2015 – the 49th Annual Meeting of the Finnish Physical Society*, Helsinki, Finland, 17–19 March 2015.
108. J. Karhunen, M. Groth, P. Heliste, T. Makkonen, A. Hakola, E. Viezzer, T. Pütterich and the ASDEX Upgrade Team, Nitrogen as a spectroscopic tracer for measuring

- plasma flows in the high-field side SOL of ASDEX Upgrade, 1st EPS conference on Plasma Diagnostics, Frascati, Italy, 14–17 April 2015.
109. S. Äkäslompolo, T. Kurki-Suonio, G. Tardini, G. Bonneure, the ASDEX Upgrade Team, Reverse ASCOT simulation of fusion product activation probe experiment in ASDEX Upgrade tokamak, 1st EPS conference on Plasma Diagnostics, Frascati, Italy, 14–17 April 2015.
 110. E. Lerche, M. Goniche, P. Jacquet, D. Van Eester, V. Bobkov, L. Colas, I. Monakhov, C. Noble, T. Blackman, F. Rimini, S. Brezinsek, A. Czarnačka, K. Crombé, C. Challis, R. Dumont, N. Fedorczak, C. Giroud, J. Graves, J. Hobirk, E. Joffrin, V. Kiptily, M. Lennholm, P. Lomas, C. F. Maggi, L. Aho-Mantila, P. Mantica, G. Mathews, M. -L. Mayoral, J. Mlynar, P. Monier-Garbet, M. F.F. Nave, I. Nunes, V. Petrzilka, T. Pütterich, M. Reich, A. Shaw, A. C.C. Sips, M. Tsalas, M. Valisa, JET Contributors, ICRH for mitigation of core impurity accumulation in JET-ILW, 21st Topical Conference on Radiofrequency Power in Plasmas, Lake Arrowhead, California, USA, 27–19 April 2015.
 111. J. Likonen, K. Heinola, A. De Backer, S. Koivuranta, A. Hakola, C.F. Ayres, A. Baron-Wiechec, P. Coad, G.F. Matthews, M. Mayer, A. Widdowson and JET Contributors, Deuterium trapping and release in JET ITER-like wall divertor tiles, 15th International Conference on Plasma-Facing Materials and Components for Fusion Applications, Aix-en-Provence, France, 18–22 May 2015.
 112. A. Hakola, J. Karhunen, M. Groth, A. Herrmann, K. Krieger, T. Kurki-Suonio, G. Meisl, M. Oberkofler, R. L. Neu, S. Potzel, V. Rohde, the ASDEX Upgrade Team, Gross and net erosion of tungsten in the outer strike-point of ASDEX Upgrade, 15th International Conference on Plasma-Facing Materials and Components for Fusion Applications, Aix-en-Provence, France, 18–22 May 2015.
 113. A. Widdowson, A. Baron-Wiechec, P. Batistoni, E. Belonohy, J.P. Coad, P. Dinca, D. Flammini, F. Fox, K. Heinola, I. Jepu, J. Likonen, S. Lilley, C.P. Lungu, G.F. Matthews, J. Naish, O. Pompilian, C. Porosnicu, M. Rubel, R. Villari and JET Contributors, Experience of handling beryllium, tritium and activated components from JET ITER like wall, 15th International Conference on Plasma-Facing Materials and Components for Fusion Applications, Aix-en-Provence, France, 18–22 May 2015.
 114. C. Ruset, E. Grigore, C. Luculescu, I. Tiseanu, J. Likonen, M. Mayer, M. Rubel G. F. Matthews, the JET-EFDA contributors, Investigation on the erosion/deposition processes in the ITER-like Wall divertor at JET using Glow Discharge Optical Emission Spectrometry technique, 15th International Conference on Plasma-Facing Materials and Components for Fusion Applications, Aix-en-Provence, France, 18–22 May 2015.
 115. C.C. Klepper, D. Borodin, M. Groth, M. Airila, L. Colas, P. Jacquet, A. Kirschner, A. Lasa, and the JET Contributors, Estimates of RF-Induced Erosion at Antenna-Connected Beryllium Plasma-Facing Components in JET, 15th International Conference on Plasma-Facing Materials and Components for Fusion Applications, Aix-en-Provence, France, 18–22 May 2015.
 116. D. Kogut, D. Douai, M. J. Baldwin, R. P. Doerner, D. Sinelnikov, N. Mamedov, V. Kurnaev, H.-W. Becker, T. Schwarz-Selinger, and A. Hakola, Hydrogen isotope exchange in beryllium: modelling and experiment, 15th International Conference on Plasma-Facing Materials and Components for Fusion Applications, Aix-en-Provence, France, 18–22 May 2015.
 117. E. Grigore, C. Ruset, M. Gherendi, D. Chioibas, A. Hakola, and JET contributors, Thermo-mechanical properties of W/Mo markers coatings deposited on bulk W, 15th

- International Conference on Plasma-Facing Materials and Components for Fusion Applications, Aix-en-Provence, France, 18–22 May 2015.
118. H. Bergsåker, I. Bykov, Y. Zhou, P. Petersson, G. Possnert, J. Likonen, J. Pettersson, S. Koivuranta, A.M. Widdowson and JET contributors, Deep deuterium retention and Be/W mixing at tungsten coated surfaces in the JET divertor, 15th International Conference on Plasma-Facing Materials and Components for Fusion Applications, Aix-en-Provence, France, 18–22 May 2015.
 119. J. Matejicek, V. Weinzettl, A. Macková, V. Havránek, A. Hakola, P. Petersson, H. Maier, and M. Rubel, Interaction of candidate plasma facing materials with tokamak plasma, 15th International Conference on Plasma-Facing Materials and Components for Fusion Applications, Aix-en-Provence, France, 18–22 May 2015.
 120. K. Heinola, A. Widdowson, J. Likonen, E. Alves, A. Baron-Wiechec, N. Barradas, S. Brezinsek, N. Catarino, P. Coad, S. Koivuranta, S. Krat, G.F. Matthews, M. Mayer, P. Petersson and JET Contributors, Long-term fuel retention in JET ITER-like wall, 15th International Conference on Plasma-Facing Materials and Components for Fusion Applications, Aix-en-Provence, France, 18–22 May 2015.
 121. K. Krieger, D. Brida, Y. Gao, J. Gunn, A. Hakola, A. Herrmann, T. Lunt, S. Potzel, B. Sieglin, the ASDEX Upgrade Team, Melt damage at leading edges of PFCs and its avoidance by edge shadowing, 15th International Conference on Plasma-Facing Materials and Components for Fusion Applications, Aix-en-Provence, France, 18–22 May 2015.
 122. K. Piip, H.J. van der Meiden, L. Hämarik, J. Karhunen, A. Hakola, P. Paris, M. Aints, M. Laan, J. Likonen, K. Bystrov, J. Kozlova, R. Kanarbik, In situ LIBS in the linear plasma device Pilot-PSI, 15th International Conference on Plasma-Facing Materials and Components for Fusion Applications, Aix-en-Provence, France, 18–22 May 2015.
 123. L. Moser, L. Marot, R. Steiner, M. Newman, A. Widdowson, D. Ivanova, J. Likonen, P. Petersson, G. Pintsuk, M. Rubel, E. Meyer and JET Contributors, Plasma cleaning of beryllium coated mirrors, 15th International Conference on Plasma-Facing Materials and Components for Fusion Applications, Aix-en-Provence, France, 18–22 May 2015.
 124. M. Mayer, S. Krat, W. Van Renterghem, A. Baron-Wiechec, S. Brezinsek, I. Bykov, P. Coad, Y. Gasparyan, K. Heinola, J. Likonen, A. Pisarev, C. Ruset, G. de Saint-Aubin, A. Widdowson, the JET Contributors, Erosion and deposition in the JET divertor during the first ILW campaign, 15th International Conference on Plasma-Facing Materials and Components for Fusion Applications, Aix-en-Provence, France, 18–22 May 2015.
 125. M. Oberkofler, G. Meisl, A. Hakola, A. Drenik, D. Alegre, S. Brezinsek, R. Craven, T. Dittmar, T. Keenan, S. G. Romanelli, R. Smith, D. Douai, A. Herrmann, K. Krieger, U. Kruezi, G. Liang, C. Linsmeier, M. Mozetic, V. Rohde, the ASDEX Upgrade team, the EUROfusion MST Team, JET Contributors, Nitrogen retention mechanisms in tokamaks with Be and W plasma-facing surfaces, 15th International Conference on Plasma-Facing Materials and Components for Fusion Applications, Aix-en-Provence, France, 18–22 May 2015.
 126. M. Pribula, M. Suchonova, M. Hornackova, J. Plavcan, A. Hakola, and P. Veis, Use of the Near Vacuum UV Spectral Range for the Analysis of W-based Materials for Fusion Applications Using LIBS, 15th International Conference on Plasma-Facing Materials and Components for Fusion Applications, Aix-en-Provence, France, 18–22 May 2015.
 127. R. Mateus, N. Catarino, E. Alves, C. Porosnicu, C. P. Lungu, and A. Hakola, Effects of deuterium and nitrogen implantation on Be-W coatings grown by TVA, 15th

- International Conference on Plasma-Facing Materials and Components for Fusion Applications, Aix-en-Provence, France, 18–22 May 2015.
128. S. Wiesen, M. Groth, S. Brezinsek, M. Wischmeier and JET contributors, Modelling of plasma-edge and plasma-wall interaction physics at JET with the metallic first-wall, 15th International Conference on Plasma-Facing Materials and Components for Fusion Applications, Aix-en-Provence, France, 18–22 May 2015.
 129. Y. Hatano, K. Yumizuru, J. Likonen, S. Koivuranta, J. Ikonen and JET Contributors, Tritium distributions on tungsten and carbon tiles used in the JET divertor, 15th International Conference on Plasma-Facing Materials and Components for Fusion Applications, Aix-en-Provence, France, 18–22 May 2015.
 130. A. Hakola, J. Karhunen, J. Likonen, M. Aints, P. Paris, K. Piip, H. van der Meiden, Development of laser-induced breakdown spectroscopy to determine the composition of deposited layers in fusion reactors, Northern Optics & Photonics 2015, Lappeenranta, Finland, 2–4 June 2015.
 131. M. Rubel, P. Petersson, E. Alves, S. Brezinsek, J. P. Coad, K. Heinola, M. Mayer, A. Widdowson, the JET Contributors, The Role and Application of Ion Beam Analysis for Studies of Plasma-Facing Components in Controlled Fusion Devices, 22nd International Conference on Ion Beam Analysis, Opatia, Croatia, 14–19 June 2015.
 132. A. Gurchenko, E. Gusakov, P. Niskala, A. Altukhov, L. Esipov, T. Kiviniemi, T. Korpilo, D. Koupienko, S. Lashkul, S. Leerink, A. Perevalov, M. Irzak, The isotope effect in turbulent transport control by GAMs. Observations and gyrokinetic modelling, 42nd EPS Conference on Plasma Physics, Lisbon, Portugal, 22–26 June 2015.
 133. P. Niskala, T.P. Kiviniemi, S. Leerink, T. Korpilo, Gyrokinetic investigation of isotope effect on flow oscillations in ohmic tokamak discharges, 42nd EPS Conference on Plasma Physics, Lisbon, Portugal, 22–26 June 2015.
 134. A. Salmi, T. Tala, A. Järvinen, P. Mantica, L. Meneses, S. Mordjick, V. Naulin, J. Juul Rasmussen, J. Svensson, L. Giacomelli, R. Gomes, M. Groth, T. Koskela, C. Maggi, M. Maslov, G. Sips, H. Weisen and the JET contributors, Particle source and edge transport studies in JET H-mode gas puff modulation experiments, 42nd EPS Conference on Plasma Physics, Lisbon, Portugal, 22–26 June 2015, Paper P2-135.
 135. K. Krieger, J. W. Coenen, J. P. Gunn, A. Hakola, T. Lunt, S. Potzel, the ASDEX Upgrade Team, Efficiency of surface shaping for protection of leading edges in the divertor of ASDEX Upgrade from direct plasma exposure, 42nd EPS Conference on Plasma Physics, Lisbon, Portugal, 22–26 June 2015, Paper P1-129.
 136. M. Beurskens, M. G. Dunne, L. Frassinetti, M. Bernert, M. Cavedon, R. Fischer, A. Järvinen, A. Kallenbach, F. M. Lagner, R. M. McDermott, G. Tardini, E. Viezzer, E. Wolfrum, the ASDEX Upgrade Team, the EUROfusion MST team, The role of Carbon on the H-mode confinement in ASDEX Upgrade with a metal wall, 42nd EPS Conference on Plasma Physics, Lisbon, Portugal, 22–26 June 2015, Paper P1-102.
 137. R. McDermott, T. Odstrcil, C. Angioni, B. Duval, A. Karpushov, R. Fischer, A. Salmi, T. Tala, G. Tardini, E. Viezzer, the ASDEX Upgrade Team, Diffusive and non-diffusive contributions to momentum transport in AUG experiments and the European intrinsic rotation database, 42nd EPS Conference on Plasma Physics, Lisbon, Portugal, 22–26 June 2015, Paper P1-118.
 138. T. Tala, A. Salmi, C. Bourdelle, C. Giroud, J. Hillesheim, C. Maggi, P. Mantica, L. Meneses, M. Maslov, S. Menmuir, S. Moradi, S. Mordjick, V. Naulin, J. Juul Rasmussen, G. Sips, A. Sirinelli, M. Tsalas, H. Weisen and the JET contributors,

- Dimensionless Collisionality Scans for Core Particle Transport in JET, 42nd EPS Conference on Plasma Physics, Lisbon, Portugal, 22–26 June 2015, Paper P2-136.
139. M.P. Gryaznevich, M. Nightingale, P. Buxton, O. Asunta, S. McNamara, A. Nicolai, A. Salmi, T. Tala, Towards Compact Fusion Reactor: Fast Particle Issues, 14th IAEA Technical Meeting on Energetic Particles in Magnetic Confinement Systems, Vienna, Austria, 1–4 September 2015.
 140. P. A. Schneider, B. Geiger, M. Weiland, S. Äkäslompolo, F. Ryter, G. Tardini, the ASDEX Upgrade Team, Overview of diagnostic enhancements and measurements of confined fast-ions in ASDEX Upgrade, 14th IAEA Technical Meeting on Energetic Particles in Magnetic Confinement Systems, Vienna, Austria, 1–4 September 2015.
 141. T. Korpilo, T.P. Kiviniemi, S. Leerink, P. Niskala, and R. Rochford, Gyrokinetic modelling of tokamak plasma edge in circular limiter configuration, 15th International Workshop on Plasma Edge Theory in Fusion Devices, Nara, Japan, 9–11 September 2015.
 142. I. Ivanova-Stanik, L. Aho-Mantila, M. Wischmeier, R. Zagórski, the JET Contributors, COREDIV and SOLPS numerical simulations of the nitrogen seeded JET ILW L-mode discharges, 15th International Workshop on Plasma Edge Theory in Fusion Devices, Nara, Japan, 9–11 September 2015.
 143. F. Granberg et al., High-fluence irradiation effects in equiatomic Fe-based alloys, 7th N-Fame Workshop, Getafe, Spain, 21–22 September 2015.
 144. F. Djurabekova, M. Ullah, F. Granberg, K. Nordlund, K. Jin, Y. Zhang, W. J. Weber, Atomistic simulations of radiation damage in high entropy alloys, 17th International Conference on Fusion Reactor Materials, Aachen, Germany, 11–16 October 2015.
 145. F. Granberg, D. Terentyev, K. Nordlund, Effect of obstacle nanostructure on the movement of dislocations, 17th International Conference on Fusion Reactor Materials, Aachen, Germany, 11–16 October 2015.
 146. K. Nordlund, A.E. Sand, F. Granberg, S.J. Zinkle, R. Stoller, R.S. Averback, T. Suzudo, L. Malerba, F. Banhart, W.J. Weber, F. Willaime, S. Dudarev, D. Simeone, Improving the dpa equation to account for athermal defect recombination and radiation mixing: arc-dpa and rpa, 17th International Conference on Fusion Reactor Materials, Aachen, Germany, 11–16 October 2015.
 147. J. Polvi and K. Nordlund, Development of interatomic potential for W-N-H system, 17th International Conference on Fusion Reactor Materials, Aachen, Germany, 11–16 October 2015.
 148. E. Safi, J. Polvi and K. Nordlund, Atomistic simulations of D irradiation on Fe alloys in ITER vacuum vessel, 17th International Conference on Fusion Reactor Materials, Aachen, Germany, 11–16 October 2015.
 149. A.E. Sand, K. Nordlund, D.R. Mason, X. Yi, S.L. Dudarev, Spatial distributions of primary defects from massive collision cascades in tungsten, 17th International Conference on Fusion Reactor Materials, Aachen, Germany, 11–16 October 2015.
 150. F. Granberg, Stråliningsskador i multikomponentlegeringar, Finlandssvenska fysik och kemidagarna, Helsinki/Stockholm, Finland/Sweden, 13–15 November 2015.
 151. P. Niskala, T.P. Kiviniemi, T. Korpilo, S. Leerink, R. Rochford, Gyrokinetic investigation of turbulent flow dynamics in tokamak plasmas, FuseNet PhD Event 2015, Prague, Czech Republic, 15–18 November 2015.
 152. A. Salmi, T. Tala, M. Lanctot, J.S. deGrassie, C. Paz-Soldan, N. Logan, W.M. Solomon, B.A. Grierson, Investigation of torque generated by Test Blanket Module

- mock-up in DIII-D, 57th Annual Meeting of the APS Division of Plasma Physics, Savannah, Georgia, USA, 16–20 November 2015.
153. C. Chrystal, W.M. Solomon, B.A. Grierson, T. Tala, A. Salmi, J.S. deGrassie, Scaling of Intrinsic Torque with Normalized Gyroradius in DIII-D, 57th Annual Meeting of the APS Division of Plasma Physics, Savannah, Georgia, USA, 16–20 November 2015.
 154. S. Mordijck, X. Wang, L. Zeng, E.J. Doyle, T. Tala, A. Salmi, Particle transport in DIII-D and JET plasmas, 57th Annual Meeting of the APS Division of Plasma Physics, Savannah, Georgia, USA, 16–20 November 2015.
 155. F. Granberg, Investigation of the effect of carbides on dislocation movement; a combination of MD and DDD, Advances in materials & processing technologies 2015, Madrid, Spain, 14–17 December 2015.
 156. P. Sirén, Generating of the fusion plasma neutron source, International Workshop in Fusion Neutronics, Cambridge, UK.
 157. P. Sirén, M. Airila, J. Leppänen, S. Äkäslompolo, Generating of fusion plasma neutron source with AFSI for Serpent MC neutronics computing, Serpent UGM, Knoxville, TN.
 158. T. Tala, A. Salmi, C. Bourdelle, C. Giroud, R. Gomes, M. Groth, J. Hillesheim, A. Järvinen, C. Maggi, P. Mantica, L. Meneses, M. Maslov, S. Menmuir, S. Moradi, S. Mordijck, V. Naulin, J. Juul Rasmussen, G. Sips, A. Sirinelli, M. Tsalas, H. Weisen and the JET contributors, Experimental Core and Edge Particle Transport Studies in JET, US/EU Transport Task Force Workshop - Salem, MA.
 159. P. Sirén, M. Airila, J. Leppänen, S. Äkäslompolo, Generating of fusion plasma neutron source with AFSI for Serpent MC neutronics computing, X ITER Neutronics Meeting.

11.5.3 Research reports

160. K. Nordlund, A.E. Sand, F. Granberg, S. J. Zinkle, R. Stoller, R. S. Averback, T. Suzudo, L. Malerba, F. Banhart, B. Weber, F. Willaime, S. Dudarev, and D. Simeone, Primary radiation damage in materials: Review of current understanding and proposed new standard displacement damage model to incorporate in-cascade mixing and defect production efficiency effects, Report NEA/NSC/DOC(2015)9, OECD Nuclear Energy Agency (2015).
161. M. Airila and A. Hakola (eds.), FinnFusion Yearbook 2014, VTT Science **91** (2015).
162. M. Airila and T. Tala (eds.), Association Euratom-Tekes final summary report 2007–2013, VTT Technology **214** (2015).

11.5.4 Academic theses

163. P. Alho, Service-based Fault Tolerance for Cyber-Physical Systems: A Systems Engineering Approach, Doctoral dissertation, Tampere University of Technology, Tampere 2015.
164. O. Asunta, Fast Ions in Fusion Plasmas – Towards Numerical Tokamaks, Doctoral dissertation, Aalto University, Espoo 2015.
165. A. Järvinen, Radiative divertor studies in JET high confinement mode plasmas, Doctoral dissertation, Aalto University, Espoo 2015.

166. T. Koskela, Monte Carlo simulation of fast ion losses in ITER in the presence of static 3D magnetic perturbations, Doctoral dissertation, Aalto University, Espoo 2015.
167. H. Martínez Landa, Problems analysis and solutions for the establishment of augmented reality technology in maintenance and education, Doctoral dissertation, Tampere University of Technology, Tampere 2015.
168. J. Miettunen, Modelling of global impurity transport in tokamaks in the presence of non-axisymmetric effects, Doctoral dissertation, Aalto University, Espoo 2015.
169. K. Särkimäki, Relativistic runaway electron simulations in 3D background, MSc. thesis, Aalto University, Espoo 2015

Title	FinnFusion Yearbook 2015
Author(s)	Markus Airila (Ed.)
Abstract	<p>This Yearbook summarises the 2015 research activities of the FinnFusion Consortium that was established in 2014. The present emphasis of the FinnFusion programme is the following: (i) Technology R&D for ITER construction and systems including industry contracts; (ii) Implementation of the "Fusion Roadmap to the Realization of Fusion Energy" as a member of the EUROfusion Consortium with projects focusing on tokamak experiments and modelling; (iii) Creating concepts for the next generation fusion power plant DEMO in Europe.</p> <p>The members of FinnFusion are VTT Technical Research Centre of Finland Ltd., Aalto University, Fortum Corporation (new member in 2015), Lappeenranta University of Technology, Tampere University of Technology, University of Helsinki and Åbo Akademi University.</p> <p>FinnFusion Consortium participates in several EUROfusion work packages. The largest ones are experimental campaigns at JET and ASDEX Upgrade and related analyses, materials research, plasma-facing components and remote maintenance. DEMO work on power plant modelling was intensified by the engagement of Fortum after a successful start in 2014.</p> <p>EUROfusion supports post-graduate training through the education work package that allowed FinnFusion to partly fund 10 PhD students within FinnFusion members. In addition, three post-doctoral fellowships funded by the Consortium were running in 2015. FinnFusion also provided three NJOC secondees at JET and one EUROfusion Program Management Unit secondee.</p> <p>The F4E activities of FinnFusion continued seamlessly from previous years. Aalto University completed 3D modelling of magnetic fields and related fast particle losses grant, demonstrating that escaping energetic particles will not pose a threat to the first wall of ITER. As far as remote handling is concerned, year 2015 saw continuation for successful demonstrations of divertor handling operations.</p> <p>FinnFusion Annual Seminar 2015 was organised at VTT in Tampere in May.</p>
ISBN, ISSN, URN	ISBN 978-951-38-8431-4 (Soft back ed.) ISBN 978-951-38-8432-1 (URL: http://www.vttresearch.com/impact/publications) ISSN-L 2242-119X ISSN 2242-119X (Print) ISSN 2242-1203 (Online) http://urn.fi/URN:ISBN:978-951-38-8432-1
Date	May 2016
Language	English, Finnish abstract
Pages	79 p.
Name of the project	
Commissioned by	
Keywords	nuclear fusion, fusion energy, fusion research, fusion physics, fusion technology, fusion reactors, fusion reactor materials, ITER remote handling, Euratom
Publisher	VTT Technical Research Centre of Finland Ltd P.O. Box 1000, FI-02044 VTT, Finland, Tel. 020 722 111

Nimeke	FinnFusion-vuosikirja 2015
Tekijä(t)	Markus Airila (toim.)
Tiivistelmä	<p>Tähän vuosikirjaan on koottu vuonna 2014 perustetun FinnFusion-konsortion vuoden 2015 tulokset. Konsortion ohjelman painopistealueet ovat (i) ITER-reaktorin rakentamiseen ja järjestelmiin liittyvän teknologian kehitys yhdessä teollisuuden kanssa; (ii) osallistuminen Fuusion tiekartan toteuttamiseen EUROfusion-konsortion jäsenenä tarjoamalla erityisesti tokamak-kokeisiin ja mallinnukseen liittyvää osaamista; (iii) seuraavan sukupolven eurooppalaisen DEMO-fuusiovoimalan konseptikehitys.</p> <p>FinnFusion-konsortion muodostavat Teknologian tutkimuskeskus VTT Oy, Aalto-yliopisto, Fortum Oyj (uusi jäsen 2015), Lappeenrannan teknillinen yliopisto, Tampereen teknillinen yliopisto, Helsingin yliopisto ja Åbo Akademi.</p> <p>FinnFusion-konsortio osallistuu useisiin EUROfusion-projekteihin. Suurin työpanos kohdistuu JET- ja ASDEX Upgrade -koelaitteissa tehtäviin kokeisiin ja analyyseihin, materiaalitutkimukseen, ensiseinämakomponentteihin ja etäkäsittelyyn. Edellisenä vuonna lupaavasti käynnistyneeseen DEMO-laitoksen prosessimallinnukseen saatiin uusia resursseja Fortumin mukaan tulon myötä.</p> <p>EUROfusion tukee jatko-opiskelua omalla rahoitusinstrumentillaan, jonka turvin FinnFusion rahoitti osittain kymmenen jatko-opiskelijan työtä jäsenorganisaatioissaan. Lisäksi vuoden 2015 aikana oli käynnissä kolme EUROfusionin rahoittamaa tutkijatohtorin projektia. Kolme FinnFusionin tutkijaa toimi lähetettyinä työntekijöinä JET:n käyttöorganisaatiossa (NJOC) ja yksi EUROfusionin hallinnossa (Program Management Unit).</p> <p>FinnFusionin F4E-työt jatkuivat saumattomasti edellisiltä vuosilta. Aalto-yliopiston monivuotisessa magneettikentän ja nopeiden hiukkasten yksityiskohtaiseen 3D-mallinnukseen kohdistuvassa hankkeessa osoitettiin, että karkaavat suurienergisäiset hiukkaset eivät uhkaa ITERin ensiseinämän eheyttä. Tampereella sijaitsevalla DTP2-koelaitteistolla jatkettiin vuonna 2015 menestyksekkäitä divertorin käsittelyn demonstraatioita.</p> <p>Fuusioalan vuosiseminaari 2015 järjestettiin VTT:llä Tampereella toukokuussa.</p>
ISBN, ISSN, URN	ISBN 978-951-38-8431-4 (nid.) ISBN 978-951-38-8432-1 (URL: http://www.vtt.fi/julkaisut) ISSN-L 2242-119X ISSN 2242-119X (Painettu) ISSN 2242-1203 (Verkkójulkaisu) http://urn.fi/URN:ISBN:978-951-38-8432-1
Julkaisu aika	Toukokuu 2016
Kieli	Englanti, suomenkielinen tiivistelmä
Sivumäärä	79 s.
Projektin nimi	
Rahoittajat	
Avainsanat	nuclear fusion, fusion energy, fusion research, fusion physics, fusion technology, fusion reactors, fusion reactor materials, ITER remote handling, Euratom
Julkaisija	Teknologian tutkimuskeskus VTT Oy PL 1000, 02044 VTT, puh. 020 722 111

FinnFusion Yearbook 2015

This Yearbook summarises the 2015 research activities of the FinnFusion Consortium that was established in 2014. FinnFusion Consortium participates in several EUROfusion work packages. The largest ones are experimental campaigns at JET and ASDEX Upgrade and related analyses, materials research, plasma-facing components and remote maintenance. DEMO work on power plant modelling was intensified by the engagement of Fortum after a successful start in 2014.

EUROfusion supports post-graduate training through the education work package that allowed FinnFusion to partly fund 10 PhD students within FinnFusion members. In addition, three post-doctoral fellowships funded by the Consortium were running in 2015. FinnFusion also provided three NJOC secondees at JET and one EUROfusion Program Management Unit secondee.

The F4E activities of FinnFusion continued seamlessly from previous years. Aalto University completed 3D modelling of magnetic fields and related fast particle losses grant, demonstrating that escaping energetic particles will not pose a threat to the first wall of ITER. As far as remote handling is concerned, year 2015 saw continuation for successful demonstrations of divertor handling operations.

FinnFusion Annual Seminar 2015 was organised at VTT in Tampere in May.

ISBN 978-951-38-8431-4 (Soft back ed.)
ISBN 978-951-38-8432-1 (URL: <http://www.vttresearch.com/impact/publications>)
ISSN-L 2242-119X
ISSN 2242-119X (Print)
ISSN 2242-1203 (Online)
<http://urn.fi/URN:ISBN:978-951-38-8432-1>

