

11010
01011
01000
00110



• VISIONS • SCIENCE • TECHNOLOGY • RESEARCH HIGHLIGHTS •

Dissertation
139

Exploring the transport system under technological change – market, business ecosystem and business model viewpoints

Zulkarnain



Exploring the transport system under technological change – market, business ecosystem and business model viewpoints

Zulkarnain

VTT Technical Research Centre of Finland Ltd

University of Oulu Graduate School

University of Oulu

Faculty of Technology, Industrial Engineering and Management

Academic dissertation for the degree of Doctor of Science (Technology) to be presented with the assent of the Doctoral Training Committee of Technology and Natural Sciences of the University of Oulu for public defence in Lecture Hall TS 101, at the University of Oulu, Linnanmaa, on 1 December 2016, at 12 noon.



ISBN 978-951-38-8471-0 (Soft back ed.)

ISBN 978-951-38-8470-3 (URL: <http://www.vttresearch.com/impact/publications>)

VTT Science 139

ISSN-L 2242-119X

ISSN 2242-119X (Print)

ISSN 2242-1203 (Online)

<http://urn.fi/URN:ISBN:978-951-38-8470-3>

Copyright © VTT 2016

JULKAISIJA – UTGIVARE – PUBLISHER

Teknologian tutkimuskeskus VTT Oy

PL 1000 (Tekniikantie 4 A, Espoo)

02044 VTT

Puh. 020 722 111, faksi 020 722 7001

Teknologiska forskningscentralen VTT Ab

PB 1000 (Teknikvägen 4 A, Esbo)

FI-02044 VTT

Tfn +358 20 722 111, telefax +358 20 722 7001

VTT Technical Research Centre of Finland Ltd

P.O. Box 1000 (Tekniikantie 4 A, Espoo)

FI-02044 VTT, Finland

Tel. +358 20 722 111, fax +358 20 722 7001

Cover image: Zulkarnain

Juvenes Print, Tampere 2016

In the name of Allah, the Most Beneficent, the Most Merciful

Dedicated to: my parents and my wife

¶ And it is He Who spread out the earth, and placed therein firm mountains and rivers and of every kind of fruits He made *Zawjain lthnain* (two in pairs - may mean two kinds or it may mean: of two sorts, e.g. black and white, sweet and sour, small and big, etc.) He brings the night as a cover over the day. Verily, in these things, there are *Ayat* (proofs, evidences, lessons, signs, etc.) for people who reflect.¶

Holy Quran (13:3).

¶ And of His signs is the creation of the heavens and the earth and the diversity of your languages and your colors. Indeed, in that are signs for those of knowledge.+

Holy Quran (30:22).

Acknowledgements

All praise is due Allah, the Lord of the Worlds, the Most Beneficent and the Most Merciful. He bestowed me with strength and motivation during my journey to finish this doctoral study. If not for His willingness and guidance, this dissertation would not have been completed. This is by the Grace of my Lord.

The doctoral study is quite a long journey that needs passion and persistence. It can only be finished through the support, cooperation and collaboration with several persons. Therefore, I would like to express my gratitude to all those who contributed towards this research in the form of data, valuable advice, and comments. First, I would like to thank my thesis supervisor at the University of Oulu, Professor Pekka Kess. He provided me with kind supervision, supportive advice and guidance from the beginning of the research until the end of the journey at the university although I spent most of my time in VTT. I was very lucky to have him as a supervisor, and for his dedication, I express my great appreciation. I would also express my deepest gratitude to my thesis supervisor at VTT, Dr Pekka Leviäkangas. He gave me the opportunity to come from Indonesia to Finland to work at VTT as a research scientist and a VTT graduate school student. I really appreciate his patience, excellent guidance and invaluable discussions during the research. He is a great mentor and a good friend.

I would also like to thank the follow-up group members: Professor Harri Haapasalo at the University of Oulu, Research Professor Heikki Ailisto at VTT, and Principal Scientist Dr Anu Tuominen at VTT for their time and effort, discussions, support, and advice in following up the research and making sure that the research was in order. I also thank the pre-examiners, Professor Tzong-Ru (Jiun-Shen) Lee at the National Chung Hsing University, Taiwan, and Professor Jussi Kantola at the University of Vaasa, Finland for their time and effort in reviewing the dissertation and providing constructive comments and suggestions in the final phase. I also thank Professor Heikki Liimatainen from Tampere University of Technology, Finland for being the opponent on the dissertation committee.

I thank my co-authors for their contribution to the published articles included in this dissertation: Dr. Pekka Leviäkangas, Mr. Juho Kostiainen, Mr. Raine Hautala, Mr. Mikko Tarkiainen, Mr. Teppo Kivento, Professor Pekka Kess, Dr. Aki Aapaoja, Dr. Tuomo Kinnunen, and Mr. Eetu Pilli-Sihvola. Because of their generous contributions, these papers provided the empirical materials for the dissertation.

I would also express my gratitude to VTT Technical Research Centre of Finland Ltd for providing the financial support through its VTT graduate school programme, INTRANS Innovation Programme, and several projects funded by Tekes . the Finnish Agency for Innovation and European Union during my work as a VTT research scientist: ITS Market, EWENT, EVELINA, HeERO, MOBINET, FIRWE, and BECSI. VTT provided a good working environment, and I was very lucky to be part of the organisation. I thank my superiors in VTT for their support during my doctoral studies from the beginning: former technology manager Dr. Heikki Kanner, former team leader and mentor Dr. Anu Tuominen, former team leader Mr. Jukka Laitinen, Head of Research Area Dr. Riikka Virkkunen, and team leader Ms. Merja Penttinen. I also thank VTT Graduate School Programme Coordinator Dr. Kristiina Poppius-Levlin (formerly) and Dr. Jukka Ketoja for their provision of good programmes and support to the VTT graduate school students. I would like to express my gratitude to my former colleagues in VTT for their invaluable cooperation: Dr. Matti Roine, Mr. Raine Hautala, Dr. Satu Innamaa (former mentor), Ms. Jenni Eckhardt (former mentor), Research Professor Minna Isomursu (former mentor), Mr. Petri Mononen (former mentor), Mr. Juho Kostianen, Mr. Eetu Pilli-Sihvola, Mr. Mikko Tarkiainen, Mr. Teppo Kivento, Dr. Aki Aapaoja, Dr. Thomas Casey, Dr. Karri Rantasila, Ms. Anna-Maija Hietajarvi, Mr. Risto Öörni, Dr. Riitta Molarius, Dr. Ville Könönen, Mr. Jussi Rönty, Ms. Eija Posio, as well as all the members of the VTT transport team whom I have not mentioned. It has been a pleasure to work with them, and I really appreciate their help, cooperation and collaboration during my work in VTT. I also thank VTT for publishing the dissertation and Ms. Anni Repo for her kind help with the publication process.

I would like to acknowledge the financial support from the Ministry of Transport and Communications Finland, COST Action TU-1001, University of Oulu Graduate School (UniOGS), and Yliopiston Apteekin Rahasto fund. They assisted me with travel grants to attend conferences and summer schools as well as a personal grant to support my living costs.

I also want to thank my colleagues at the University of Indonesia, especially in the Department of Industrial Engineering, my colleagues at the University of Oulu, my companions at madrasah 78, my relatives, my *brothers* at Pohjois-Suomen Islamilainen Yhdyskunta, and my friends in Indonesia and Finland for their support and prayers.

Finally, my very special gratitude is for my beloved family in Indonesia: my parents Mr. Mohammad Afriandi and Mrs. Kartini, my brothers Fery and Mohamad Amrullah, and my parents-in-law Mr. Saleh Utih and Mrs. Tjutju Karningsih who always support me and pray for my success; and of course, my beloved wife, Novi Dewi Tanjung, who has faithfully been with me throughout my studies here in Finland. Their love, support, prayers, and patience are priceless; they helped me and motivated me to complete my studies, especially during difficult days.

Thank you all very, very much.

Oulu, Finland, October 2016
Zulkarnain

Academic dissertation

Supervisor	Professor Pekka Kess Industrial Engineering and Management, University of Oulu Oulu, Finland
Co-supervisor, Custos	Docent Dr. Pekka Leviäkangas Industrial Engineering and Management, University of Oulu Principal Scientist, VTT Technical Research Centre of Finland Ltd Oulu, Finland
Follow up group members	Professor Harri Haapasalo (chairman) Industrial Engineering and Management, University of Oulu Oulu, Finland Research Professor Heikki Ailisto VTT Technical Research Centre of Finland Ltd Oulu, Finland Principal Scientist Dr. Anu Tuominen VTT Technical Research Centre of Finland Ltd Espoo, Finland
Preliminary examiners	Professor Tzong-Ru (Jiun-Shen) Lee Marketing Department, National Chung Hsing University Taichung, Taiwan Professor Jussi Kantola Department of Production, University of Vaasa Vaasa, Finland
Opponent	Assistant Professor Heikki Liimatainen Transport Research Centre Verne, Tampere University of Technology Tampere, Finland

List of publications

This dissertation is based on the following original publications which are referred to in the text as Articles I. V. The publications are reproduced with kind permission from the publishers.

- I Zulkarnain, Leviäkangas P, Tarkiainen M, Kivento T. 2012. Electric vehicles market outlook . potential consumers, information services and sites test. International Journal of Technology 3(2): 156. 168.
- II Zulkarnain, Leviäkangas P. 2012. The size, structure and characteristics of Finland's ITS industry. Technology and Investment 3(3): 158. 167.
- III Leviäkangas P, Aapaoja A, Kinnunen T, Pilli-Sihvola E, Hautala R, Zulkarnain. 2014. The Finnish road weather business ecosystem . turning societal benefits into business and the other way round. Engineering Management Research 3(1): 56. 67.
- IV Zulkarnain, Leviäkangas P, Kinnunen T, Kess P. 2014. The electric vehicles ecosystem model: Construct, analysis and identification of key challenges. Managing Global Transition: International Research Journal 12(3): 253. 277.
- V Kostiainen J, Zulkarnain, Leviäkangas P, Hautala R. 2013. Business model evolution for ITS services. 20th ITS World Congress, 14. 18 October 2013, Tokyo, Japan. 9 p.

Author's contributions

The author of this doctoral dissertation (Zulkarnain) is mainly the corresponding and primary author of the original publications, except Articles III and V. The author's contributions to each article are described as follows.

- I The author participated in planning the work and carrying out the research process, including the data collection and analysis. The author interpreted the results and wrote the article with the co-authors (Pekka Leviäkangas, Mikko Tarkiainen, and Teppo Kivento).
- II The author participated in planning the work and carrying out the research process, including the data collection and analysis. The author interpreted the results and wrote the article with the co-author (Pekka Leviäkangas). The author presented the results at the ITS World Congress in Vienna in 2012.
- III The author was a member of the research team and took part in the writing, checking and finalising the paper. The author was also a corresponding author of the paper. The co-authors of paper were Aki Aapaoja, Tuomo Kinnunen, Eetu Pilli-Sihvola and Raine Hautala.
- IV The author participated in planning the work and carrying out the research process, including gathering the data, reviewing the literature, and constructing the ecosystem model. The author interpreted the results and wrote the article with the co-authors (Pekka Leviäkangas, Tuomo Kinnunen and Pekka Kess).
- V The author participated in gathering the data and the materials, and he collaborated in the writing process. The author made particular contributions to chapter 2 and several parts of chapter 3.

Table of Contents

Acknowledgements	4
Academic dissertation.....	6
List of publications.....	7
Author's contributions	8
Abbreviations	11
1. Introduction.....	14
1.1 Background and research environment	14
1.1.1 Intelligent transport systems.....	16
1.1.2 Electrification of transport systems	19
1.1.3 Winter road weather and maintenance systems.....	21
1.2 Scope and objective	25
1.3 Research process and philosophy.....	27
1.4 Research strategies, data collection and analysis methods	30
2. Theoretical foundation.....	33
2.1 Market research and analysis.....	33
2.1.1 Definition and terminology.....	33
2.1.2 Methods, typologies, and measures	35
2.2 Business ecosystem	37
2.2.1 Concepts and research highlights.....	37
2.2.2 Relation with other concepts	41
2.3 Business model	43
2.3.1 Origin, definitions, and key components.....	43
2.3.2 Business model taxonomies.....	48
2.3.3 Business model evaluation and evolution	51
2.4 Theoretical synthesis and reflections.....	52
3. Research contribution	56
3.1 Summary of articles.....	56
3.1.1 Article I: Electric vehicles market outlook . potential consumers, information services and sites test.....	56
3.1.2 Article II: The size, structure and characteristics of Finland's ITS industry.....	57
3.1.3 Article III: The Finnish road weather business ecosystem . turning societal benefits into business and the other way round.....	58
3.1.4 Article IV: The electric vehicles ecosystem model . construct, analysis and identification of key challenges	60
3.1.5 Article V: Business model evolution for ITS services	63

3.2	Research findings and answers to research questions.....	63
3.3	Research synthesis	71
3.3.1	Transport information-intensive system.....	72
3.3.2	Electro-mobility system	74
3.3.3	Road weather and maintenance system	76
3.3.4	Scaling up towards a generic framework.....	77
4.	Discussion and evaluation.....	81
4.1	Implications	81
4.2	Reliability and validity of the research approach.....	83
4.3	Recommendations for future research.....	85
	References.....	87

Appendices

Appendix A: Reference projects

Appendix B: Articles I. V

Abstract

Abbreviations

ACC	Adaptive Cruise Control
APTS	Advanced Public Transportation System
ARTS	Advanced Rural Transports System
ATIS	Advanced Traveler Information System
ATMS	Advanced Traffic Management System
AVCS	Advanced Vehicles Control System
B2B	Business-to-Business
B2C	Business-to-Consumer
BE	Business Ecosystem
BEAM	Business Ecosystem Analysis and Modelling
BEV	Battery Electric Vehicle
BN	Business Network
C2C	Consumer-to-Consumer
CBA	Cost Benefit Analysis
CEA	Cost Effectiveness Analysis
CFA	Cash Flow Analysis
CNG	Compressed Natural Gas
CNO	Collaborative Networked Organisation
CO ₂	Carbon dioxide
CV	Conventional Vehicle
CVCA	Customer Value Chain Analysis
CVO	Commercial Vehicles Operation

DRSC	Dedicated Short Range Communications
DSS	Decision Support System
ERGO	Electric Recharge Grid Operator
ESOMAR	European Society for Opinion and Marketing
ESS	Environmental Sensor Stations
ETC	Electronic Toll Collection
EU	European Union
EV	Electric Vehicle
FCW	Forward Collision Warning
FCV	Fuel Cell Vehicle
FHWA	Federal Highway Administration
GDP	Gross Domestic Product
GHG	Greenhouse gas
GMVN	Global Manufacturing Virtual Network
GPS	Global Positioning System
HEV	Hybrid Electric Vehicle
ICC	International Chamber of Commerce
ICE	Internal Combustion Engine
ICT	Information and Communications Technology
IO	Industry Organisation
ITS	Intelligent Transport System
KPI	Key Performance Indicator
M&A	Merger and Acquisition
MaaS	Mobility-as-a-Service
MAN	Metropolitan Area Networks
MCA	Multi Criteria Analysis
MOBENA	Methodology of Business Ecosystem Network Analysis
OI	Open Innovation
PHEV	Plug-in Hybrid Electric Vehicle
PPP	Public-Private Partnership

RQ	Research Question
RWIS	Road Weather Information System
SA	Strategic Alliance
SCM	Supply Chain Management
V2G	Vehicle-to-Grid
V2I	Vehicle-to-Infrastructure
V2V	Vehicle-to-Vehicle
VBE	Virtual organisation Breeding Environment
VMS	Variable Message Sign
WLAN	Wireless Local Area Networks

1. Introduction

1.1 Background and research environment

The transport system is continuously evolving. A modern transport system needs to be sustainable socially, economically and environmentally. In Nordic countries such as Finland, climate change, globalisation, the shortage of public funding and technological development are significant forces that affect the entire transport system (Finnish Ministry of Transport and Communications, 2009).

Transport policy makers have become concerned about the climate change caused by the increasing of greenhouse gas (GHG) emissions. The transport sector is responsible for a quarter of European Union (EU) GHG emissions, which is the second biggest GHG emitting sector after energy. More than two-thirds of transport-related GHG emissions are by road transport. Furthermore, while GHG emissions in other sectors decreased by 24% from 1990 and 2009, those in the transport sector increased 29% during the same period (Hill et al., 2012).

Globalisation has changed the structure of the transport industry, which is now borderless. The industry operates globally to meet market demands worldwide, which calls for agile and intense mobility of both people and goods. Hence, the current transport system needs to maintain its highest performance. However, public funding has been reduced because of population ageing and workforce reduction. Consequently, public services must be provided as efficiently as possible. Therefore, transport policy makers must find new ways to meet the society's mobility and transport needs while utilising a reduced budget.

Furthermore, technological improvements and changes over centuries have yielded cheaper, faster and better transport services (Garrison, 2000). Technology developed and improved rapidly. Garrison pointed out that improvement matters, not only of vehicles, facilities, and propulsion but also of services. The emphasis should be on the processes that have induced and steered technological advances, increased the variety of services, and enabled transportation to serve an increasing range of purposes. The process of technological change can be defined as the cumulative economic or environmental impact of new technology in three stages: *invention*, *innovation*, and *diffusion* (Jaffe et al., 2003). Jaffe et al. adopted Schumpeter's (1942) three steps or stages in the process by which a new, superior technology penetrates the marketplace. Technological change can be measured in several ways: scoring models, data analyses, surveys, growth models and indicators (Kim, 2012).

In recent decades, the rapid technological change, especially in information and communication technology (ICT) furthermore has affected the transport system. In many sectors, including the transport sector, digitalisation has increased the effectiveness and efficiency of systems. The intelligent transport system (ITS) has emerged in the digitalisation era. The acronym ITS refers to the transport sector's adoption and application of ICT in all modes of transport, both passengers and

goods. ITSs can improve the performance of the transport system by reducing congestion, GHG emissions, fatalities and injuries at several levels (see e.g. Leviäkangas, 2013). Because of these capabilities, ITSs have the potential to provide a better transport system in Finland, which is ranked second among high-tech societies by the World Economic Forum (Dutta et al., 2015). Consequently, ITSs have been included in Finland's national strategy for transport policy.

It is predicted that the automotive industry will play a significant role in ITS deployment. However, Finland has a relatively small automotive industry, which will lead to some potential challenges during the ITS deployment. Nonetheless, Finland has to find a way to succeed the ITS implementation. Hence, this research is conducted to explore the domestic ITS industry as a starting point in understanding the ITS industry structure in Finland. The lessons learned from this research will be useful for both policy makers and business owners in deciding what can be done in the next step.

The *helicopter view* is effective in exploring and understanding the research problem because it provides a big picture of the problem as well its details. This research attempts to implement this approach to explore the emerging transport system.

In a narrow scope, a winter road weather and maintenance system could be one of the most relevant and interesting subjects to be studied in this Nordic country. Extreme winter phenomena are challenging, and they require specific measures to provide an effective and efficient transport system for the end user. Winter road management is closely related to ITS by definition, as several applications and equipment are used in the winter road weather and maintenance system, and they utilise a wide range of ICTs. Furthermore, Finland has excellent expertise in this area as well as mature and complete stakeholders within the ecosystem. This is one of the competitive clusters of ITSs that Finland can optimise in order to differentiate it from the other parts of the ITS industry actors around the globe.

In addition to the ITS, the electric vehicle (EV) system has emerged in the transport sector. In reducing the dependence on gasoline as the energy source for transport as well as addressing increasing environmental concerns, EVs have become an important segment to be reintroduced to the market. Moreover, from the perspective of transport policy, EVs are also part of the worldwide agenda for green and sustainable transport in the future. Based on these factors, this research attempts to include the electrification of mobility as a case study to be explored. The key challenges for the deployment of EVs are interesting topics that need to be studied and further taken into account, especially if the electro-mobility campaign is to be successful. In this case study, the high helicopter view is used, as the EV system is explored from a global perspective.

The transport systems emerging in this digitalisation era call for a number of research activities. Unfortunately, most of the current researches on this topic have focused on the technical side, such as developing, prototyping and testing the technologies. However, little research has been conducted on the business aspect (Giannoutakis and Li, 2012). Therefore, this dissertation aims to enrich the analysis of the emerging transportation sector from the business perspective and provide insights for future research.

The following section will briefly introduce each case explored in this research. Collectively, these case studies form the basis of this study.

1.1.1 Intelligent transport systems

The recent development on ICTs has changed various aspects of everyday life. Digitalisation has improved many sectors, including basic industries, education, health care and construction. It is now in the early stages of transforming the transport system. With the help of ICTs, the transport sector could perform better and have a wide range of positive economic, social and environmental effects. The implementation of ICTs to improve the performance of transport systems results in ITS, which is *the collective term for the use of electronics, communications, and information processing technology to improve all aspects of transportation, including public transportation* (The Intelligent Transportation Society of America, 2011). ITSs are a high-growth segment within the transport sector.

ITS utilise various advanced technologies, such as the internet, global positioning system (GPS), dedicated short range communications (DSRC), wireless communications, sensing technologies and computational technologies to improve all aspects and modes of the transportation of both passengers and goods. ITS have significantly improved the performance of transport systems, including reduced congestion, increased safety and enhanced travel convenience. Although ITS may refer to all modes of transport, the EU Directive 2010/40/EU (7 July 2010) defined ITS as systems in which ICTs are applied in the field of road transport, including infrastructure, vehicles and users, in traffic management and mobility management, as well as in interfaces with other modes of transport (European Commission, 2010).

ITS have a broad range of applications in practice (Figure 1). There is no commonly accepted taxonomy of ITS, since there are hundreds of systems and applications that were designed for specific purposes, as well as a growing number of new devices (Giannoutakis and Li, 2011). However, ITS are generally categorised as *intelligent infrastructure* and *intelligent vehicle*. Intelligent infrastructure includes systems and applications that are designed for road transport infrastructure, such as loop detectors, electronic toll collection (ETC) and variable message sign (VMS). The term intelligent vehicle refers to in-vehicle systems and applications, such as navigation devices, adaptive cruise control (ACC) and forward collision warning (FCW).



Figure 1. Intelligent transport systems (adapted from European Telecommunications Standards Institute, 2012)

Wootton et al. (1995) introduced six ITS major categories: advanced traffic management systems (ATMS); advanced travellers information systems; commercial vehicles operation (CVO); advanced public transportation systems (APTS), advanced vehicles control systems (AVCS); and advanced rural transports systems (ARTS). Several examples of real systems among the six major ITS categories were also presented by Figueiredo et al. (2001). Additional ITS categories include ITS-enabled transportation pricing systems, fully integrated ITS systems (V2I and V2V Systems), and value-added services (Ezell, 2010 and Berkers et al., 2013).

The US Department of Transportation (2005) compiled 33 user services of ITS and divided them into eight categories or bundles. The services within these bundles may be related in a number different ways, and they share common characteristics and features. Table 1 shows the bundles of ITS user services.

Table 1. ITS user services (The US Department of Transportation, 2005)

Bundle	User Services
1. Travel and Traffic Management	1.1 Pre-Trip Travel Information 1.2 En-Route Driver Information 1.3 Route Guidance 1.4 Ride Matching and Reservation 1.5 Traveller Services Information 1.6 Traffic Control 1.7 Incident Management 1.8 Travel Demand Management 1.9 Emissions Testing and Mitigation 1.10 Highway-Rail Intersection
2. Public Transportation Management	2.1 Public Transportation Management 2.2 En-route Transit Information 2.3 Personalised Public Transit 2.4 Public Travel Security
3. Electronic Payment	3.1 Electronic Payment Services
4. Commercial Vehicle Operations	4.1 Commercial Vehicle Electronic Clearance 4.2 Automated Roadside Safety Inspection 4.3 On-Board Safety and Security Monitoring 4.4 Commercial Vehicle Administrative Processes 4.5 Hazardous Materials Security and Incident Response 4.6 Freight Mobility
5. Emergency Management	5.1 Emergency Notification and Personal Security 5.2 Emergency Vehicle Management 5.3 Disaster Response and Evacuation
6. Advanced Vehicle Safety Systems	6.1 Longitudinal Collision Avoidance 6.2 Lateral Collision Avoidance 6.3 Intersection Collision Avoidance 6.4 Vision Enhancement for Crash Avoidance 6.5 Safety Readiness 6.6 Pre-Crash Restraint Deployment 6.7 Automated Vehicle Operations
7. Information Management	7.1 Archived Data
8. Maintenance and Construction Management	8.1 Maintenance and Construction Operations

ITS products and services have been increasingly developed, and their myriad benefits have been introduced. These benefits are promising for new business opportunities and investors. The benefits of ITS have been studied in recent research. Kristensen (2011) estimated that ITS could reduce 50% of the social costs of congestion and 25% of fatality costs. Another study by Ferreira (2010) estimated that ITS could reduce congestion by 5. 15%; result in 5. 15% fewer fatalities; cause 5. 10% fewer injuries, and possibly save 10. 20% of CO₂ emissions. The Finish Transport Agency estimated the effects of various ITS applications as reported in several national and international studies (Kulmala and Schirokoff, 2009). The estimated effects of ITS varied from 2. 35% fewer fatalities, 1. 34% fewer injuries, 1. 20% less congestion and 0.5. 20% fewer emissions.

However, Leviäkangas (2013) argued that solid empirical data on the effects and benefits of ITSs are still lacking. The assessment of ITS benefits is not a straightforward matter, and it continues to pose significant challenges. Several techniques

have been applied in socio-economic assessments of ITS. Cost-benefit analysis (CBA) is used frequently even though it has some limitations (Stevens, 2004), such as in the evaluation of effects that are difficult to calculate in monetary units. Therefore, in combination with other tools, such as cost effectiveness analysis (CEA) and multi-criteria analysis (MCA), CBA could be used to tackle those issues (see e.g., Juan et al., 2003; Leviäkangas and Lähesmaa, 2002).

1.1.2 Electrification of transport systems

The increasing attention to oil reserve depletion and environmental pollution in recent years has drawn attention to the benefits of EVs, which are seen as a more viable alternative than conventional vehicles. The electrification of transport systems has been developed recently around the world as one method of creating a sustainable and green transport system. Many countries actively participate in developing an electro-mobility programme, such as by funding research programmes, testing operations and infrastructures and promoting via incentives. Electricity is a reasonable substitute for oil as an energy vector for vehicle propulsion. Thus, it ensures the security of the energy supply in the transport sector. This sector could also utilise a wide range of other renewable and carbon-free energy sources to support the national targets in reducing the GHG emissions.

EVs use one or more electric motors for propulsion. Broadly, EVs could be divided into three different types: hybrid electric vehicle (HEV), plug-in hybrid electric vehicle (PHEV), and battery electric vehicle (BEV). HEVs combine an internal combustion engine (ICE) and an electric motor for propulsion, which can be configured either in series or in parallel configuration. The battery used in HEVs can be recharged by converting the braking energy into electricity as an alternative to conventional fuel. PHEVs are HEVs in which the battery is recharged by external power sources. BEVs have only rechargeable electric propulsion and eliminate the use of conventional fuel (Figure 2). EVs include a broad range of vehicles, including electric cars, buses, trucks, trains, trams, bikes, light duty vehicles and aircraft.

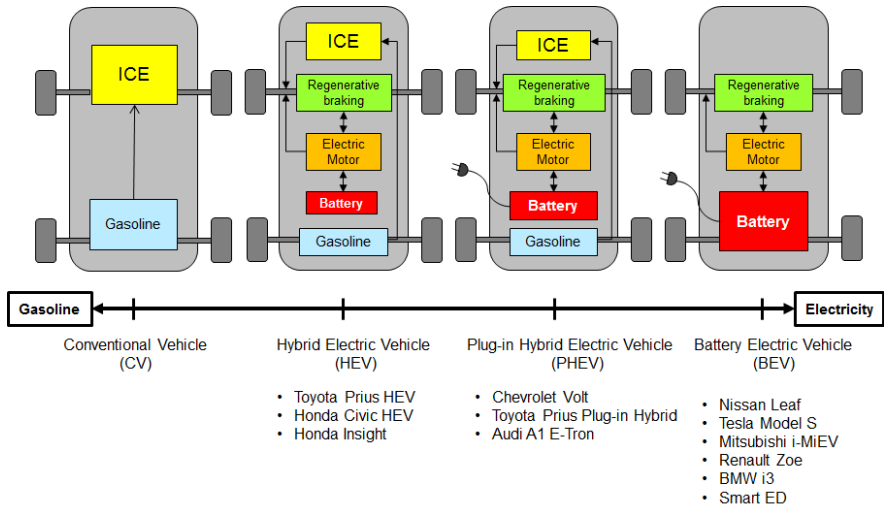

Figure 2. Electric vehicle types and configurations

Historically, EVs were introduced and operated more than a century ago before the advent of gasoline-powered vehicles. Guarnieri (2012) explained the journey of EVs from the first electric motors built in 1827, which were used to power a tiny car in 1828. Several developments followed: a small-scale electric car was produced in 1832, and a crude electric carriage was built between 1832 and 1839. Electric railway cars were developed in the same period. However, the first-generation electric cars had inefficient energy sources until further technological advancement occurred in the mid-nineteenth century. Guarnieri (2012) described some early practical electric cars in several countries, noting that they had the highest success in the period 1900-1910. In the US, electric cars captured 38% of the car market. Other contributions were the steam car (40%) and the gasoline car (22%). However, the use of electric cars at that time decreased because the increasing road network in 1920 called for cars with greater range, the oil prices fell, Ford introduced an efficient manufacturing system, which produced gasoline cars, which were more reliable and comfortable than electric cars were. After 1920, electric cars gradually disappeared, being used for a few services, such as golf carts in the US and milk delivery in Great Britain. During the last few decades, the environmental impact of the fuel-powered transport system along with volatile oil prices have led to increasing interest in the electrification of the transport system.

From the perspective of transport policy, EVs have a strategic role in creating a sustainable transport system in the near future. Policy makers worldwide are starting to introduce environmentally friendly vehicles into a broad market. For example, in Europe, the Directive 2009/33/EC of the European Parliament and of the Council of 23 April 2009 on the promotion of clean and energy-efficient road transport vehicles were launched, which is expected to result in the wide deployment of clean and

energy-efficient vehicles. The Directive requires vehicle purchasers to take into account the energy and environmental effects (i.e., energy consumption, CO₂ emissions, and emissions of NO_x, NMHC and particulate matter) associated with the operation of vehicles over a lifetime when purchasing a vehicle (European Commission, 2009a).

Electric vehicle 'tank-to-wheels' efficiency is claimed to a factor of about three higher than conventional vehicles (European Commission, 2012). Unlike ICE vehicles, energy is not consumed while the EVs are stationary. Even though the well-to-wheel efficiency is still lower, Curran et al. (2014) found that EVs have a better well-to-wheels efficiency (~22%. 35%) compared with compressed natural gas (CNG) vehicles (~11%. 22%) if the electricity used for charging is from the same sources of energy, such as natural gas. EVs do not emit CO₂ and other pollutants (i.e., NO_x, NMHC and particulate matter), and they provide quiet and smooth operation, thus creating less noise and vibration.

The electrification of transport (electro-mobility) is a priority in the EU Community Research Programme. The European Green Cars Initiative is one of the three public-private partnerships included in the European Economic Recovery Plan (European Commission 2009b), which was endorsed by the European Council on 11. 12 December 2008. The financial support for this initiative is " 5 billion, which is aimed at boosting the automotive industry in the time of economic hardship, and maintaining support for the development of new, sustainable forms of road transport, particularly EVs (European Commission, 2012).

The European Commission also supports a Europe-wide electro-mobility initiative, through Green eMotion (<http://www.greenemotion-project.eu/>), worth " 41.8 million, with 42 partners from industry, utilities, electric car manufacturers, municipalities, universities and technology and research institutions. The aim of the initiative is to exchange and develop expertise and experience in selected regions within Europe as well as to facilitate the market rollout of EVs in Europe. The Commission will make " 24.2 million available to finance part of the initiative's activities (European Commission, 2012).

1.1.3 Winter road weather and maintenance systems

Weather phenomena obviously influence the transport system, especially extreme weather events, such as windstorms, blizzards, hail, thunderstorms, wind gusts, extremely low temperatures, extreme heat, flash floods/rainfall, tornadoes, volcanoes, lightning, fog, freezing-rain, frost and drought. Leviäkangas et al. (2011) conducted an exhaustive review of the literature on the effects of extreme weather on different modes of the transport system. Several attempts to assess the risks of extreme weather in Europe were made by Leviäkangas et al. (2013) and Molarius et al. (2014). These studies were originally part of the EU-funded project, EWENT (<http://ewent.vtt.fi/index.htm>).

Finland is a Nordic country that is geographically positioned between the 60th and 70th parallels in the Eurasian coastal zone, which has the characteristics of

both maritime and continental climates. Finland's transport systems are affected by its climate zone of *temperate coniferous-mixed forest* and cold, wet winters¹. The average temperature in the warmest month is no lower than 10 °C and that of the coldest month no higher than -3 °C. Rainfall is moderate in all seasons. The weather types can change rapidly, especially in wintertime. The Asian continental climate sometimes extends to Finland, causing severe cold in winter and extreme heat in summer.

These climate characteristics can cause several possible extreme weather events that have a wide range of effects on Finland's transport systems. Particularly in winter, a well-managed traffic management system is essential. Recent advanced technologies can be used to manage the traffic and transport systems effectively and efficiently, as well as several ITS products and services, such as road weather information systems (RWIS). The US Department of Transportation, the Federal Highway Administration (FHWA) defined RWIS as follows:

A Road Weather Information System (RWIS) is comprised of Environmental Sensor Stations (ESS) in the field, a communication system for data transfer, and central systems to collect field data from numerous ESS. These stations measure atmospheric, pavement and/or water level conditions. Central RWIS hardware and software are used to process observations from ESS to develop nowcasts or forecasts, and display or disseminate road weather information in a format that can be easily interpreted by a manager. RWIS data are used by road operators and maintainers to support decision-making (The U.S. Department of Transportation . Federal Highway Administration, 2013).

The RWIS is used to monitor several winter conditions: 1) ice or snow formation; 2) frost on bridges; 3) black ice or refrozen moisture; 4) deep water or snow; 5) friction or grip; 6) chemical concentration; and 7) freezing point of solutions on the surface (Vaisala, 2015). In addition, RWIS networks support winter road operations in several significant ways (White et al., 2006):

1. They improve the accuracy of decision-making by providing an understanding of actual road temperatures, trends and forecast accuracy.
2. They monitor road temperature, wet/dry status, freezing point of the solution on the road, the presence of chemicals and concentrations as well as sub-surface temperatures.

¹ Finnish Meteorological Institute, *Climate in Finland*, [Online] Available from: <http://en.ilmatieteelaitos.fi/climate> [Accessed: 18 November 2015]

3. When atmospheric sensors are installed on a tower, they can provide real-time localised information about atmospheric conditions, such as precipitation, relative humidity, dew point, air temperature and wind speed and direction.
4. Weather forecast providers can use the information to assist in the provision of localised road weather forecasts to help the highway authorities decision-making. The data can also be used to verify the quality of the weather forecasts.
5. Anti-icing and de-icing chemical usage can be optimised through the accurate deployment of equipment and the application of chemicals.
6. Additional sensors can be added to an RWIS to further support the highway authority in maintaining the road network, such as devices used to measure road friction and snow cover, and automated liquid de-icer application systems.

Leviäkangas et al. (2015) defined the technical architecture of the Finnish road weather information system as a meta-system comprising several extensive standalone or integrated systems, infrastructure of the sensor and observation network, and key databases. Figure 3 illustrates the technical architecture of the RWIS in Finland.

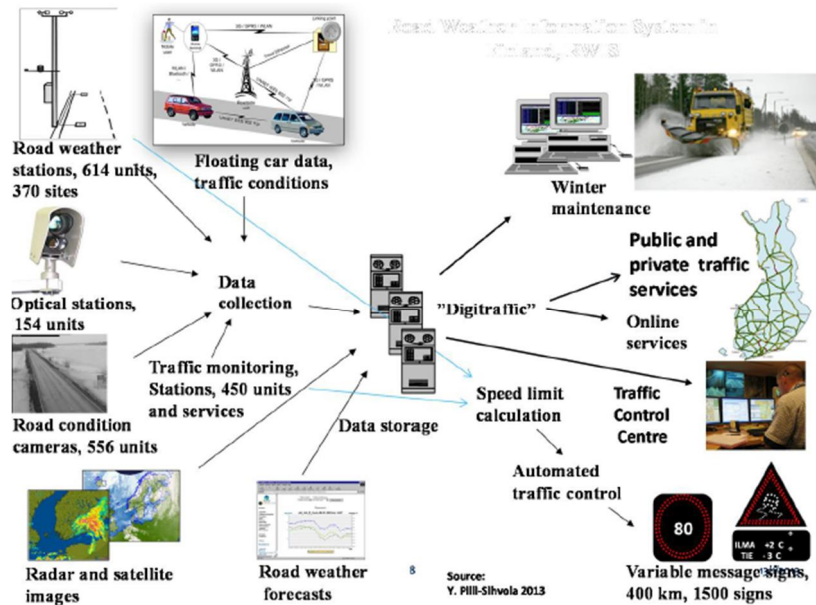

Figure 3. Technical view of the RWIS architecture (adapted from Pilli-Sihvola, 2013)

By mitigating the effects on transport systems of extreme weather events, road weather solutions can provide significant societal benefits. Pilli-Sihvola et al. (2012) examined the benefits of winter road weather information in the domain of road transport and classified them into several user groups (i.e., road users, fleet managers, infrastructure owners, and maintenance operators) and types of benefits. Pilli-Sihvola et al. reviewed several existing research results on the benefits of winter road weather information (e.g., Boselly, 2001; Meyer Mohaddes Associates Inc., 2004; Maccubbin et al., 2008; Öörni et al., 2010; Hautala and Leviäkangas, 2007).

Boselly (2001) identified some benefits of RWIS and de-icing technology in the US, such as improved driver information, increased maintenance efficiency, reduced environmental negative impacts and improved safety. The study estimated a potential benefit-cost ratio of around five points. Furthermore, Meyer Mohaddes Associates Inc. (2004) claimed several positive impacts of RWIS on US rural roads, including improved winter road maintenance efficiency and the enhanced convenience of travellers. Maccubbin et al. (2008) pointed out that in the US, 80.94% of motorists that accessed online traveller information found that RWIS increased their safety and preparation for adverse weather conditions. Moreover, the same study found a 10.30% reduction in sanding and chemical applications; 10.50% lower snow and ice control costs; and 7.83% reduced crash rates because of the effective anti-icing and pre-wetting strategies used in response to up-to-date road weather information.

In Finland, a study by Öörni et al. (2010) showed that the improvements in the road weather infrastructure in 2003 through updates to the road weather stations, sensors and analysis software resulted 25% fewer injury accidents and 50% fewer fatal accidents annually, compared with the situation in 1998. The savings in annual accident costs were also estimated to be "5.1 million greater in 2003 than in 1998. Moreover, another study from Hautala and Leviäkangas (2007) estimated the safety benefits of providing RWIS for road users to be from "16 million to "32 million and an estimated "2.7 million in total maintenance cost savings.

Another informative summary of existing research on road weather information was provided by Leviäkangas and Hietajarvi (2010). They reviewed several different studies and synthesised the value of weather information. One of the most notable results of the study was the value-shift trend in weather information from the public good in the past, public-private partnerships (PPP) in the present, to the private good in the future. Three simplified examples of road weather information applications were examined, including RWIS, VMS and weather-info services. All these applications were claimed to be moving in relatively the same direction (i.e. from public to private). Thus, the method used to evaluate the system would shift from a socio-economic CBA to a cash flow analysis (CFA). Technological change was reported as the factor that caused the shift.

1.2 Scope and objective

The purpose of this study is to explore the emerging transport system from several viewpoints and by using empirical case studies to gain new insights that are useful in practice and theory. The scope of this research is road transport. Other modes of transport, such as rail, maritime, and aviation are excluded from this research. Hence, some other emerging technologies and applications outside the road transport domain, such as personal rapid transit, unmanned ships, magnetic levitation (maglev) trains, and space elevators, will not be taken into account although some commonalities between them and the focus of this dissertation might exist. This research utilises several applications on ITS, EVs, and road weather and maintenance network case studies as the main sources of the empirical materials. Furthermore, this research focuses on the business and economic aspects of road transport from the perspectives of the market, business ecosystems and business models. However, the technological and social aspects of analysis are also considered in this research under some circumstances (Figure 4).

With regard to the geographical scope, this research is primarily concentrated in Finland, where all research activities are conducted, especially in the case study on ITS and road weather and maintenance system. Nevertheless, in observing a broad scope of phenomena, the global perspective is used to some extent, particularly in the case study of EVs.

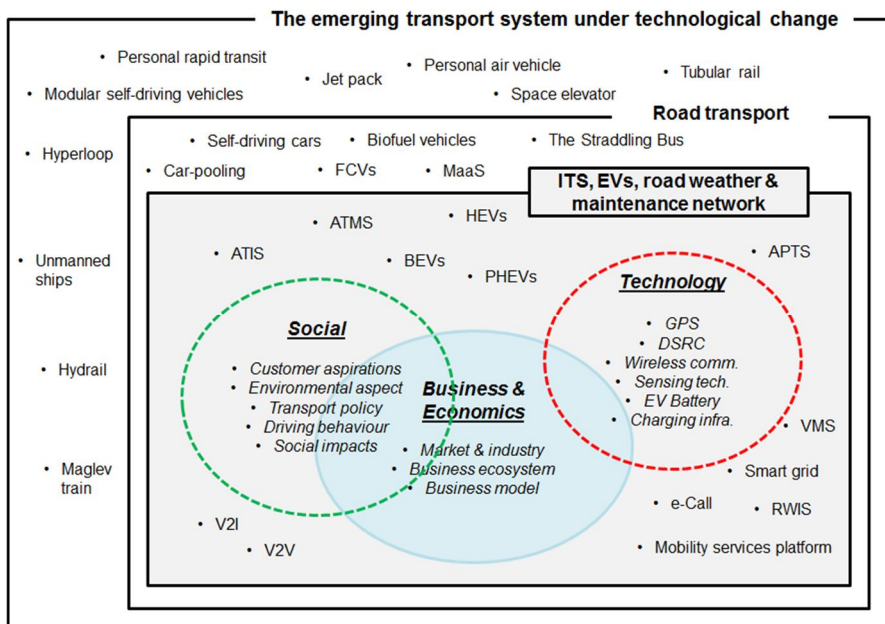

Figure 4. Research scope

The research objective is as follows:

To identify the characteristics of the market, business ecosystem, and business model in the emerging transport system under technological change.

Based on this research objective, three research questions (RQ) were derived, as shown in Table 2. The research questions in this dissertation typically consist of one main question (in bold font), followed by several sub-questions that operationalise the main question. For example, in RQ1, the main research question is **What are the characteristics of the market in the context of technological change in transport sector?** This question is further operationalised in the following sub-questions: *How do the market environment, size, trend and structure prominently figure, and what do they imply?* The same logic is also used to formulate RQ2 and RQ3, where the first question (in bold font) is the main research question and the following questions are its sub-questions. Table 2 shows how the five published articles included in this dissertation are linked and how they are used to answer the research questions.

The research questions are strongly related, and mutually supportive. All five articles aimed to address the research objective. Article I reviewed secondary research that discussed market views of EVs from a global perspective. Market information and insights in both scientific literature and market reports were utilised to understand the global EV market. The development of emerging digital information services and several EV test sites around the globe were highlighted. Article II used a quantitative approach and primary market research to conduct a market analysis of the ITS industry in Finland. The market size, market growth and market structure were examined and discussed. Articles I and II are the major sources of the empirical materials used to answer RQ1.

Articles III and IV focused on the business ecosystem analysis. The Finnish road weather and maintenance ecosystem is specifically analysed and discussed in Article III, and the global EV ecosystem is discussed in Article IV. Both articles attempted to identify the key stakeholders within the ecosystem, to define their roles and functions, to map the relationship between the actors in the ecosystem model, and to discuss the dynamics within the ecosystem. Articles III and IV provide the main materials used to answer RQ2. However, because Article IV partially discussed consumer aspirations on EVs and Article I provided initial insights about the global EV ecosystem, hence Articles IV and I are also used to answer RQ1 and RQ2 respectively.

Article V primarily aimed at analysing the business model of ITS services. The evolution from traditional to modern business models particularly discussed. Articles IV and I also address part of the business model issue. Thus, they supplement the discussion about the business model. Articles V, IV and I are used to answer RQ3.

Table 2. Research questions

RQ#	Research questions	Article#	Title
RQ1	What are the characteristics of the market in the context of technological change in transport sector? How do the market environment, size, trend and structure prominently figure, and what do they imply?	I	Electric vehicles market outlook . potential consumers, information services and sites test
		II	The size, structure and characteristics of Finland's ITS industry
		IV	The electric vehicles ecosystem model . construct, analysis and identification of key challenges.
RQ2	What are the characteristics of business ecosystem in transport system under technological change? Who are the key stakeholders and what are their roles and functions within the ecosystem? How do they build the relationships and how have the dynamics happened there?	III	The Finnish road weather business ecosystem . turning societal benefits into business and the other way round.
		IV	The electric vehicles ecosystem model . construct, analysis and identification of key challenges.
		I	Electric vehicles market outlook . potential consumers, information services and sites test
RQ3	What are the characteristics of business model in the emerging transport systems as the result of technological change? How can different business model topologies and options be examined and evaluated? What kind of strategy could be approached for designing a viable business model in the emerging transport system?	V	Business model evolution for ITS services
		IV	The electric vehicles ecosystem model . construct, analysis and identification of key challenges.
		I	Electric vehicles market outlook . potential consumers, information services and sites test

1.3 Research process and philosophy

Scientific research is always conducted from a philosophical point of view. Various considerations involved in the research process include the relationship between

theory and research, epistemological and ontological questions, research methods, values and practical issues (Bryman and Bell, 2007).

The research approach can be either deductive or inductive. In the deductive approach, an existing theory is used as the foundation for new observations and findings. In the inductive approach, new theories are developed based on observations and findings (Bryman and Bell, 2007; Saunders et al., 2009). Ontology refers to a reality wherein studied phenomena are understood to reside and the manner in which the studied phenomena are positioned in this reality. Ontology includes objectivism and constructionism. Objectivism considers that phenomena are independent of social actors, whereas constructionism assumes that phenomena and meanings are created by the actors (Bryman and Bell, 2007). Epistemological questions consider the nature and scope of knowledge. What can be known and how can the knowledge be acquired? Positivism and interpretivism are two extreme epistemological positions (Saunders et al., 2009). While the first position is typically applied in the natural sciences, the latter is mainly applied in social science. Based on these philosophical categories, the research in this dissertation is considered epistemologically and ontologically close to interpretivism and constructionism respectively. This research is empirical, mainly explorative and descriptive; it applies inductive reasoning.

The dissertation explores and analyses the emerging transport systems under technological change, focusing on the road transport sector. The phenomena under study include case studies of Finnish ITS industry, the global EVs system and the Finnish road weather and maintenance system case studies, which provide the primary empirical materials. These components are part of the existing reality of the digitalisation era today. Each component has a background and research environment that form ontological assumptions accordingly. After reflecting and understanding the reality within the ontological assumptions, one or more questions are posed for which answer(s) are required to be found. These are called the research questions. Therefore, a dedicated research is designed and conducted by utilising one or several research methods to find the answers to the identified research questions.

After defining the ontological assumptions, the research continues by looking at an existing body of knowledge that can be used as epistemological viewpoints to search for the answers to the identified research questions. In this research, three main epistemological viewpoints are utilised to understand the phenomena in the emerging field of transport: market research and analysis, business ecosystems, and business models. Each has a theoretical foundation that can be used to explain why or how such phenomena occur, which lead to answering the research questions.

The research in this dissertation is performed to answer three research questions (Table 2). In order to meet the overall objective, each research question has to be answered. The research questions (RQ1, RQ3) are classified according to the different epistemological viewpoints that were previously defined. The research also relies on three main empirical case studies on ITS, EVs, and road weather and maintenance case systems, which were conducted in several research projects in

which the author was involved during the four years of his doctoral study period (2011. 2015). They include the ITS Market Project (funded by the Ministry of Transportation and Communication Finland); EVELINA and BECSI (Tekes); MOBINET, HeERO, and EWENT (EU); and FIRWE (a customer project)².

Research can also be either qualitative or quantitative. Qualitative research refers to the meanings, definitions, concepts, characteristics, symbols, metaphors and descriptions of things, whereas quantitative research refers to measures and measurements of things, such as the distributions and proportions of subject matter (Berg and Lune, 2012). The research addresses the research questions primarily through the qualitative approach. However, the quantitative approach is also applied to some extent, such as in Article I. The research method is known as exploratory research, in which several iterative processes have been conducted to answer the research questions with the aim of synthesising the research findings to produce the results. Both the literature review and empirical research are used to answer the research questions. The research process includes case analyses and case observations. These cases manifest some of the technological changes. Therefore, combinations of several research approaches are used (as in most cases of applied research). A detailed explanation of the research methods that are used in this dissertation is presented in the next section. The research process used in this dissertation is summarised in Figure 5.

² The synopsis of each aforementioned project is presented in Appendix A.

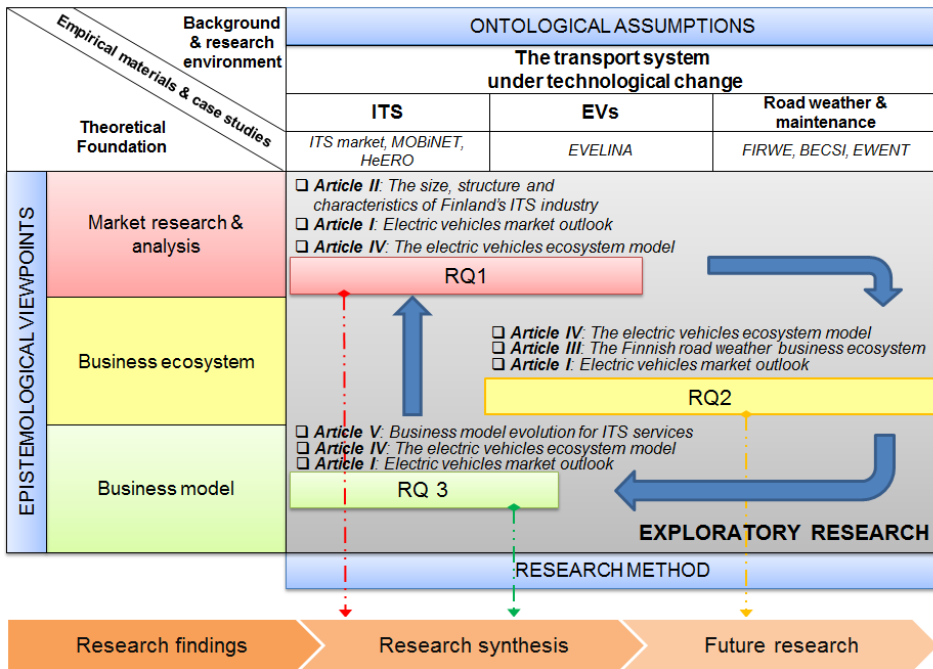

Figure 5. Research process

1.4 Research strategies, data collection and analysis methods

The research in this dissertation is exploratory in nature. Exploratory research is usually conducted to solve a problem that has not been clearly defined. It often occurs before enough is known to make conceptual distinctions or posit an explanatory relationship (Shields and Rangarajan, 2013).

The research for this dissertation applies the case study strategy, which is generally used when *how* and *why* questions are posed. The investigator has minimum control over events, and the focus is on a contemporary phenomenon within a real context. Hence, the case study strategy is appropriate for research that seeks to address practice-based problems in which the experience of the respondents is important. This strategy aims to discuss the phenomenon in depth by understanding the true environment (Yin, 2013). A literature review, focus group discussion and secondary research strategy are utilised in this research. Table 3 summarises the research strategy and data collection methods.

Table 3. The research strategy and data collection methods

RQ#	Research questions	Research strategy	Data collection methods	Analysis methods and tools
RQ1	What are the characteristics of the market in the context of technological change in transport sector? How do the market environment, size, trend and structure prominently figure, and what do they imply?	EV market case study <ul style="list-style-type: none"> • <i>Article I</i> • <i>Article IV</i> 	Literature review and secondary research (i.e. from market research reports and academic peer-reviewed articles)	Explorative analysis, literature synthesis, case study analysis, tree-structure diagram for hierarchical modelling
		ITS market case study <ul style="list-style-type: none"> • <i>Article II</i> 	Primary research through direct information (via phone, email), publicly available commercial database, financial reports	Financial analysis, descriptive statistics, Herfindahl index, stock market index
RQ2	What are the characteristics of business ecosystem in transport system under technological change? Who are the key stakeholders and what are their roles and functions within the ecosystem? How do they build the relationships and how have the dynamics happened there?	EV ecosystem case study <ul style="list-style-type: none"> • <i>Article IV</i> • <i>Article I</i> 	Literature review and secondary research	Literature synthesis, constructive research, Heuristic modelling, value network mapping, stakeholders relationship matrix

		Road weather and maintenance ecosystem case study <ul style="list-style-type: none"> • <i>Article III</i> 	Literature review, secondary research, interviews, focus group discussion ³ (workshop)	Literature synthesis, Customer Value Chain Analysis (CVCA)
RQ3	What are the characteristics of business model in the emerging transport systems as the result of technological change? How can different business model topologies and options be examined and evaluated? What kind of strategy could be approached for designing a viable business model in the emerging transport system?	ITS business model case study <ul style="list-style-type: none"> • <i>Article V</i> 	Literature review, and secondary research	Explorative analysis, literature synthesis, morphological analysis, case study analysis
		EV business model case study <ul style="list-style-type: none"> • <i>Article I</i> • <i>Article IV</i> 	Literature review and secondary research	Explorative analysis, literature synthesis, case study analysis

³ The focus group discussion was held three times: 3 October 2013, 20 November 2013 and 12 September 2014.

2. Theoretical foundation

In this chapter, several theoretical links and related literature are briefly presented. The relevant theories and references as well as related methodological discussions about them are included in this chapter. They are discussed and connected during the entire research process to facilitate the analysis.

The theoretical foundation of this dissertation comprises three major theories that are used as the main viewpoints in answering the research questions: market research and analysis, business ecosystems, and business models. Finally, in the last section, all theoretical concepts will be synthesised and summarised in accordance with the objectives of dissertation.

2.1 Market research and analysis

Market research is an essential activity in the business world, the commercial world and even the public world. It is a key factor in maintaining competitiveness, and it provides information that is important in identifying and analysing market needs, market size and market competition. Business planners require reliable market information to make a business plan. Investors demand promising market potential before they deciding to commit their money. Thus, business owners need to convince them by offering profitable market projections. Product designers and developers also find ways to better understand their potential customers' aspirations prior to making products and services and launching them in the market. Public policy makers are curious about the market of a particular industry, and they sometimes need such information to justify or rationalise their policy drafts. All these actions are performed by conducting market research.

2.1.1 Definition and terminology

Definitions of market research are relatively common and there appear to be no significant differences among them. Several complementary definitions of market research, which can be collectively used as references are the following:

- *Market research, which includes social and opinion research, is the systematic gathering and interpretation of information about individuals or organisations using the statistical and analytical methods and techniques of the applied social sciences to gain insight or support decision making. The identity of respondents will not be revealed to the user of the information without explicit consent and no sales approach will be made to them as a direct result of their having provided information (ICC/ESOMAR, 2008).*
- *McQuarrie (2005) defined market research as techniques for gathering information from and about customers to support a business decision-*

The term *market research* is often used interchangeably with *marketing research*. However, McDonald (2007) distinguished between both terms as follows: *market research is concerned specifically with research about markets, whereas marketing research is concerned with research into marketing processes*. He further quoted the definition of marketing research according to the American Marketing Association as *the systematic gathering, recording and analysis of data about problems relating to the marketing of goods and services*. Therefore, according to these definitions, for the purpose of the dissertation, the author is concerned with the first definition: market research focuses on the market of the emerging transport systems.

In addition, Brown (2008) distinguished between *market research* and *market analysis* as follows:

Market research is the scientific study of markets or marketing methods in a broad, general way. Market analysis, on the other hand, is the scientific study of the markets or marketing methods for a specific product or service, the results of which are to be used as the basis for the policies, plans, and operations of individual firm.

However, in this definition, Brown (2008) does not seem to distinguish between market and marketing research, instead emphasising that the scope of study is the differentiator. In this dissertation, the author conducts market research instead of market analysis, because it focuses simultaneously on multiple products and services (ITS and EVs) to gain insights that could be used as the basis for the future policies, plans, and operations of several firms (e.g., manufacturers, services providers, etc.) and other related actors (e.g., policy makers and public operators). However, at some point, the author cannot separate the two terminologies. During the market research process, the author might implicitly conduct a market analysis at the same time. For instance, while the author is conducting the market research

for EVs, a particular product of a company (e.g., a specific type and brand of electric car) in the EVs industry might be observed as a single entity. This can be done iteratively and simultaneously for another specific product, so that sufficient data can be retrieved to be further analysed and interpreted. Therefore, for the purpose of the dissertation, perhaps it would be better to use both terminologies simultaneously in the phrase, "market research and analysis".

2.1.2 Methods, typologies, and measures

There are two fundamental modes of doing market research, namely exploratory and confirmatory (McQuarrie, 2005). Exploratory market research is driven by the motivation to discover or generate possibilities and new ideas. Thus, most exploratory research uses *qualitative techniques*. In contrast, confirmatory market research aims at narrowing things down and eliminating possibilities in order to select the best option. Most confirmatory research uses *quantitative techniques*.

Mittal (2015) presented another framework for understanding customer-focused research (Figure 6). He categorised three different techniques according to their knowledge richness and criteria of managerial purpose. **Qualitative techniques** comprise verbal (focus groups, in-depth interviews), observational (ethnography studies), and projective techniques (metaphor elicitation), which are designed to understand why customers do what they do. **Descriptive research** is based on two types of data: primary and secondary (pre-existing data, such as sales records, online reviews, etc.). **Conclusive research** usually consists of causal studies that are designed to determine the cause-and-effect relationships through conducting an experiment.

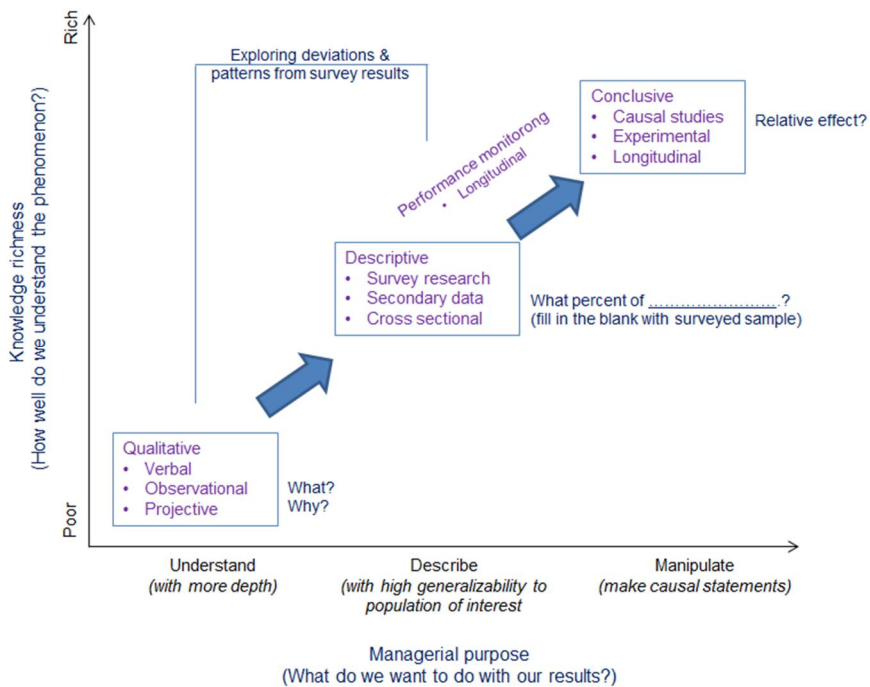

Figure 6. Framework for understanding customer-focused research (adapted from Mittal, 2015)

Brown (2008) divided the general subject of market research and analysis into specific types: 1) national market analysis and wholesale or retail market analysis; 2) industrial market analysis and consumer market analysis; 3) qualitative and quantitative analysis. Regarding the latter, he pointed out that qualitative analysis deals with the nature of the market or marketing methods, such as the kind of people who make up the market, their wants and desires, and the kind of products they prefer. Quantitative analysis is performed to measure the size of markets to determine how much of a commodity will be consumed during a future period.

Furthermore, Brown (2008) categorised market analysis into seven major types. He divided market analysis that is primarily concerned with *breaking down the market* into the following:

1. **Qualitative market analysis:** deals with the nature of the market or marketing methods, such as customers profiles, aspirations, behaviour and preferences.
2. **Quantitative market analysis:** determines the amount of a commodity that the market can be expected to absorb. The terms %sales potential+or %market potential+are usually used.

3. **Product analysis:** logically refers to qualitative analysis. However, special techniques have been developed. It is used to determine the characteristics of the market that significantly affect the nature of the product that should be produced.
4. **Market trend analysis:** studies the changes in the market for a product over a specific period to forecast future market conditions.

He grouped the *means of reaching the market* as follows:

5. **Sales analysis:** includes phases of market analysis that deal with sales records and the operation of a sales department.
6. **Dealer analysis:** concerns particular companies whose dealer is much more important than the consumer is in the success of marketing activities.
7. **Advertising and sales promotion analysis:** in certain phases of market analysis work, it is used directly to improve the efficiency of advertising that calls for special techniques.

The key disciplines used in market, social and opinion research are the social sciences of psychology, anthropology, sociology, economics and statistics (Phillips, 2007). However, Brown (2008) used the term accounting instead of economics, and he added engineering to these disciplines as the general techniques of special scientific fields that contribute to market research and analysis. He pointed out, *the techniques developed by the industrial engineer are of primary value to the market analysis+*

Although Brown (2008) argued that it was not easy to delineate the fundamental methods of market research and analysis, three fundamental factors in market research and analysis transcend a specific procedure: 1) the survey method; 2) the observational method; and 3) the experimental method.

Xu (2005) identified 10 different market measures that are frequently used because they provide a snapshot of a defined market: 1) *market environment*, 2) *market age*, 3) *market size*, 4) *market growth rate*, 5) *market share*, 6) *market potential*, 7) *market concentration*, 8) *market saturation*, 9) *market attractiveness*, and 10) *replacement rate*.

2.2 Business ecosystem

2.2.1 Concepts and research highlights

The concept of the business ecosystem has been widely known among scholars and experts, particularly in the business strategy domain, for more than two decades. Moore (1993) first proposed viewing a company not as a member of single industry but as part of a business ecosystem that crosses a variety of industries. This perspective was driven by the limitations in current frameworks and theories in assisting managers who seek to understand the underlying logic of change and in

helping executives to anticipate managerial challenges in nurturing the complex business communities that bring innovations to market. Moore (1993) identified and observed four evolutionary stages in a business ecosystem: *birth, expansion, leadership and self-renewal*. These stages should be understood by executives as important in directing change. Several longitudinal case studies of the retail, entertainment and pharmaceutical industries over time (i.e., Apple, IBM, Ford, Wal-Mart and Merck) were also conducted to determine the characteristics of each stage. Two different business strategies, cooperative and competitive, were also examined.

Gossain and Kandiah (1998) realised that there was a paradigm shift in business. A shift from the manufacturer- or grower-driven market to a customer-driven market has been experienced in this information economy era. They also supported Moore (1996), who first introduced the term 'business ecosystem' as being comprised of customers, market intermediaries (including agents and channels, and those who sell complementary products and services), suppliers, and of course, oneself. Gossain and Kandiah (1998) extended and refined Moore's original concept to recognise the importance of creating value for customers through the provision of additional information, goods, and services and the use of the internet and other enabling technologies, which are important yet absent from the original idea. According to them, value creation enables a business to distinguish itself from its competitors and provides a means of establishing a bond with its customers. Furthermore, internet technologies provide the interconnectedness that supports the creation of new business ecosystems.

Gossain and Kandiah (1998) also identified three major reasons that the new business ecosystem builds upon value chain concepts. However, the term value chain does not completely describe the new business ecosystem. The reasons are as follows: First, the term 'value chain' does not adequately capture the close symbiotic relationships between a company, its customers, its suppliers, and its partners; the relationships are more than an efficient information flow and data sharing, and partners do not add value at each stage of value chain in the new business ecosystem. Second, the relationship between organisations, partners, and customers is intimately linked and constantly evolving, and the ecosystem provides for a more fluid relationship. Third, the value chain does not take into account the importance of brand, whereas the new business ecosystem extends the relationship between competitors, complementors, and other partners to deliver services through a single brand.

Heistracher et al. (2004) presented the architectural principles of a digital business ecosystem as the collection of a distributed, open-source infrastructure, software services, and small and medium-sized enterprises. Iansiti and Levien (2004) discussed a business strategy from an ecology perspective. They defined a business ecosystem as *'loose networks . . . of suppliers, distributors, outsourcing firms, makers of related products or services, technology providers, and a host of other organisations . . . that affect and are affected by the creation and delivery of a company's own offerings'*. This definition of a business ecosystem inspired further business ecosystem researchers, such as Kim et al. (2010). Iansiti and Levien (2004)

identified three critical measures of health in business ecosystems as well as biological ecosystems: *productivity, robustness and niche creation*. They found the usefulness of applying the biological term *ecosystem* in a business context. Moreover, they investigated the keystone advantage, yet wisely warned against the dangers of domination in a business ecosystem. Matching a company's strategy to its environment has been posited as the proper way to gain benefits. The choice of ecosystem strategy can be affected by the level of turbulence and innovation, as well as the complexity of its relationships with others in the ecosystem.

In addition, Iansiti and Levien (2004) explained that different strategies work in different situations regarding those two characteristics. A *keystone (value dominator)* strategy may be the most effective in a company with a rapid changing environment and a complex network of asset-sharing relationships. In contrast, if a *commodity business* is in a stable environment and operates relatively independently of other organisations (less complexity), then an ecosystem strategy is irrelevant. Moreover, in a business with high turbulence and less complex relationships, a *niche strategy* could be the best, whereas in the opposite situation, a *physical dominator* as its best strategy.

Li (2009) presented a case study based on both qualitative and quantitative data to explain how Cisco Systems successfully utilised its mergers and acquisitions (M&A) strategy based on a business ecosystem from a technological perspective. The study used patent data to present the complex relationships between M&A targets and technology development. Li (2009) argued that symbiosis, platform, and co-evolution are three characteristics of a business ecosystem, which could be used to analyse Cisco's growth opportunities.

Following Iansiti and Levien (2004) and Moore (1993), Kim et al. (2010) defined the business ecosystem as *an economic community involving many companies working together to gain comparative advantages as a result of their symbiotic relationships* (p. 151). Furthermore, Kim et al. (2010) realised that because coordinated activities were performed by firms in a business ecosystem to produce mutual outcomes, it is critical to generate positive gains in business ecosystems. However, from the perspective of the individual companies in an ecosystem, there is no specific guideline that would help them deal with the ecosystems to which they belong. Therefore, Kim et al. used information technology (IT) to provide underlying guidelines that would allow companies to create healthy business ecosystems. Kim et al. also attempted to derive business implications from the situations of flagship companies. They argued that the flagship company's health is proof of its ecosystem's healthiness.

Battistella et al. (2012) proposed a methodology for analysing and modelling ecosystems: the methodology of business ecosystem network analysis (MOBENA). The study utilised the digital imaging ecosystem in Telecom Italia Future Centre. The methodology was claimed to be useful in drawing the shape of relationships among stakeholders, interrelated impacts, and dynamic figures by monitoring trends. MOBENA consists of four phases: 1) *ecosystem perimeter, elements, and relationships*; 2) *ecosystem model representation and data validation*; 3) *ecosystem analysis*; and 4) *ecosystem evolution*. Battistella et al. (2012) noted that the existing

modelling approaches and methodologies were limited, including e3-value modelling (Gordijn et al., 2000), c3-value modelling (Weigand et al., 2007), agent-based methodology (Marin et al., 2007), and business ecosystem analysis and modelling (BEAM) (Tian et al., 2008). They also argued that these approaches were often over-simplified and lacked strategic analysis.

Vaz et al. (2013) conducted a study that proposed a new conceptual model for business ecosystem visualisation and analysis. The study focused on the video-game ecosystem because of its high technology setting, its occurrence of superstars and its growing market. The main objective was to bring the effects of network externalities and superstar products to the visualisation and analysis of industry ecosystems. Vaz et al. gathered sales figures by publishers and in platforms, associating each sale to a single consumer and plotting these relationships. The visualisation utilised NodeXL software and Fruchterman and Reingold's (1991) algorithm. The results were presented in a graph that showed publishers' strategic positioning and node sizes that actually reflected the relevance of superstars.

Smith (2013) attempted to combine the concepts of risk management business ecosystems. His study identified possible risks that would be faced by entrepreneurs prior to entering and participating in a particular business ecosystem, which could inhibit a start-up's growth. He divided the risks as follows: 1) risks relating to categories of business ecosystems; and 2) risks relating to participating in business ecosystems. Based on a review of the relevant literature, he further categorised the business ecosystems into six types: supply systems, demand forum, platform, expanding communities, communities of destiny and multivalent. A potential strategy to manage the risks was developed and recommendations for entrepreneurs seeking to enter and participate in business ecosystem were proposed in this study.

Figure 7 briefly summarises the previous studies on business ecosystems.

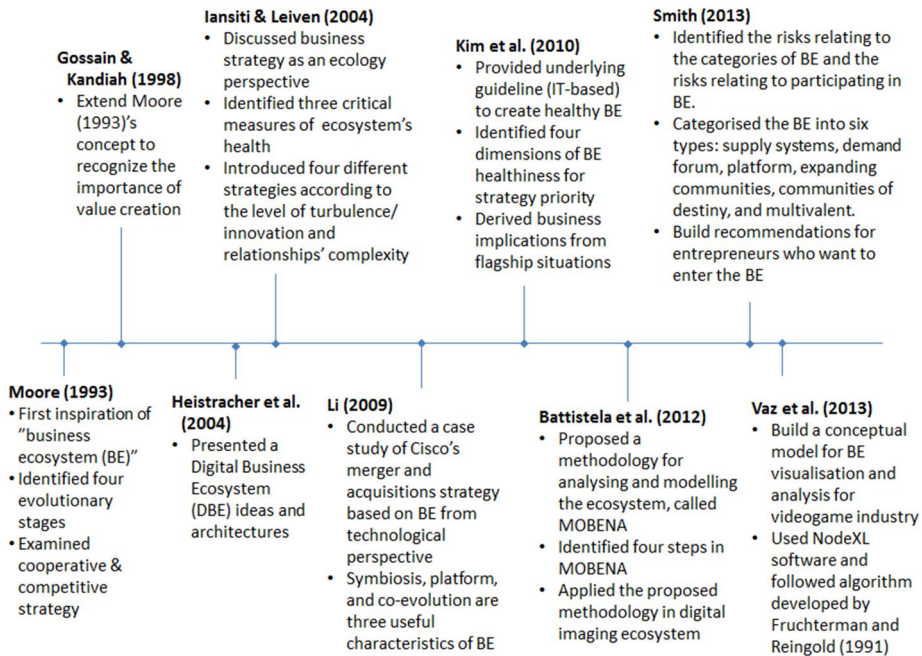

Figure 7. Research on business ecosystems

2.2.2 Relation with other concepts

Several other studies discussed the relation between business ecosystems and other concepts. For example, according to Hearn and Pace (2006) the business ecosystem was a precedent of the core idea in their study on the value ecology. They further pointed out *the shift from simple cooperation or competition to complex co-opetition*, which a business ecosystem could enable, as one of five important shifts in the conceptualisation of value creation identified by them. Camarinha-Matos et al. (2009) included the business ecosystem as an example of a virtual organisation breeding environment (VBE) manifesting among the concept of collaborative networked organisations (CNO). Peltoniemi and Vuori (2004) related the business ecosystem with complexity concepts by discussing how different complexity aspects appeared in business ecosystems. In addition, Majava et al. (2013) included business ecosystems among six business collaboration concepts (the other five are the following: *business networks, business clusters, triple helix, keiretsu, and innovation hub*). Aapaoja et al. (2014) further applied this categorisation and positioned them into four different zones based on innovation typologies and organisations' heterogeneity (Figure 8).

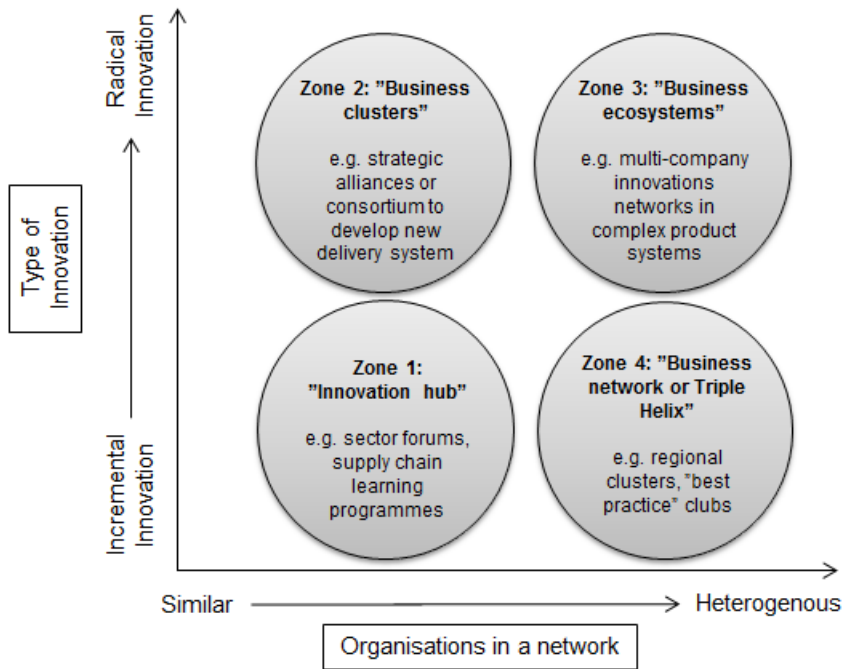

Figure 8. Four zones of collaboration concepts among innovation typologies (adapted from Aapaoja et al., 2014)

Another interesting study investigated the business ecosystem and its relationships based on seven existing network theories (Rong et al., 2010). They reviewed seven different network concepts in three streams: network structure (*supply chain [SCM], business network [BN] strategic alliance [SA]*), network strategy (*industry structure/organisation [IO] and industry cluster*), and network dynamics and evolution (*global manufacturing virtual networks [GMVN] and open innovation [OI]*) in accordance with the two industrial issues of uncertainty and interoperability. Figure 9 shows the evolution stream among those network concepts. Furthermore, Rong et al. (2010) examined the evolutionary business ecosystem from four different perspectives: *community, platform, cooperation and competition* and *co-evolution*. They used the new 6Cs research framework (*constructs, configuration, capability, cooperation, change and context*).

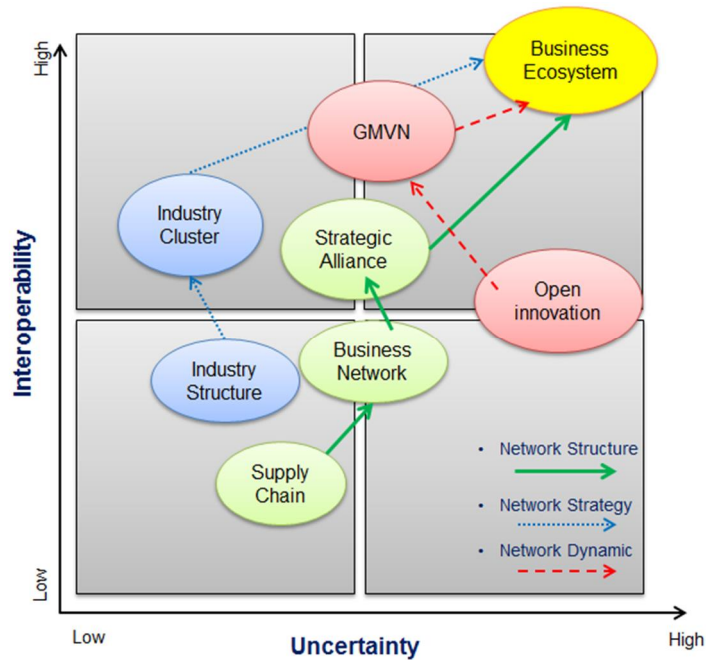

Figure 9. Evolution of existing network theories (adapted from Rong et al., 2010)

2.3 Business model

2.3.1 Origin, definitions, and key components

A competitive, rapidly changing and increasingly uncertain economic environment leads to complex and difficult business decisions. Currently, firms are dealing with new ICT, shorter product life cycles, globalisation and tighter competition. These phenomena have forced firms to become capable of managing their business effectively in order to survive the competition. Reliable concepts or tools used to facilitate firms' strategic business decisions are required in this hostile business environment. These tools allow firms to understand, assess, measure, change, communicate and simulate their business models. The current business environment is shaped by technological change (i.e. in ICT) and globalisation, and it is characterised by increasing complexity and uncertainty, which leaves managers with difficult decisions to make. Hence, the business model concept has become popular (Osterwalder, 2004).

The business model has been the focus of attention among both academics and practitioners in recent years. Since 1995, at least 1,177 papers have been published in peer-reviewed academic journal articles, among which the notion of a business

model was addressed, as noted by Zott et al. (2011). The same trend applies to practitioner-oriented studies.

In their study, Zott et al. (2011) examined the definitions of emerging business models and found that they lacked clarity. More than one-third of the 103 reviewed publications did not define the business model concept and less than one-half explicitly defined the concept. The remainder referred to other works in defining the business model concept. According to Zott et al. (2011), the several general keywords used in defining a business model comprise a *statement* (Stewart and Zhao, 2000), a *description* (Applegate, 2000; Weill & Vitale, 2001), a *representation* (Morris et al., 2005; Shafer et al., 2005), an *architecture* (Dubosson-Torbay et al., 2002; Timmers, 1998), a *conceptual tool or model* (George and Bock, 2009; Osterwalder, 2004; Osterwalder et al., 2005), a *structural template* (Amit and Zott, 2001), a *method* (Afuah and Tucci, 2001), a *framework* (Afuah, 2004), a *pattern* (Brousseau and Penard, 2006), and a *set* (Seelos and Mair, 2007). The following lists some prevailing definitions of a business model in ascending order by year.

- *The business model is the totality of how a company selects its customers, defines and differentiates its offerings, defines the tasks it will perform itself and those it will outsource, configures its resources, goes to market, creates utility for customers and captures profits+(Slywotzky, 1996).*
- *The business model is an architecture of the product, service and information flows, including a description of the various business actors and their roles; a description of the potential benefits for the various business actors; a description of the sources of revenues+(Timmers, 1998).*
- *The business model is a statement of how a firm will make money and sustain its profit stream over time+(Stewart and Zhao, 2000).*
- *The business model depicts the content, structure, and governance of transactions designed so as to create value through the exploitation of business opportunities+(Amit and Zott, 2001).*
- *Business models are stories that explain how enterprises work. A good business model answers Peter Drucker's age-old questions: Who is the customer? And what does the customer value? It also answers the fundamental questions every manager must ask: How do we make money in this business? What is the underlying economic logic that explains how we can deliver value to customers at an appropriate cost?+(Magretta, 2002).*

- *A business model is a conceptual tool that contains a set of elements and their relationships and allows expressing a company's logic of earning money. It is a description of the value a company offers to one or several segments of customers and the architecture of the firm and its network of partners for creating, marketing and delivering this value and relationship capital, in order to generate profitable and sustainable revenue streams+ (Osterwalder, 2004).*
- *A business model is a concise representation of how an interrelated set of decision variables in the areas of venture strategy, architecture and economics are addressed to create sustainable competitive advantage in defined markets.+It has six fundamental components: Value proposition, customer, internal processes/competencies, external positioning, economic model, and personal/investor factors (Morris et al., 2005).*
- *A business model consists of four interlocking elements that, taken together, create and deliver value+ These are customer value proposition, profit formula, key resources, and key processes (Johnson, Christensen and Kagermann, 2008).*
- *A business model is a reflection of the firm's realised strategy+(Casadesu-Masanell and Ricart, 2010).*
- *A business model articulates the logic, the data and other evidence that support a value proposition for the customer, and a viable structure of revenues and costs for the enterprise delivering that value+(Teece, 2010).*
- *A business model is a system of interdependent activities that transcends the focal firm and spans its boundaries+(Zott and Amit, 2010).*

According to Chesbrough and Rosenbloom (2002), a successful business model creates a heuristic logic that connects technical potential with the realisation of economic value. They further identified that the functions of a business model are the following:

1. Articulate the *value proposition*, that is, the value created for users by the offering based on the technology;

2. Identify a *market segment*, that is, the users to whom the technology is useful and for what purpose, and specify the revenue generation mechanism(s) for the firm;
3. Define the structure of the *value chain* within the firm required to create and distribute the offering, and determine the complementary assets needed to support the firm's position in this chain;
4. Estimate the *cost structure and profit potential* of producing the offering, given the value proposition and value chain structure chosen;
5. Describe the position of the firm within the *value network* linking suppliers and customers, including identification of potential complementors and competitors;
6. Formulate the *competitive strategy* by which the innovating firm will gain and hold an advantage over rivals.

Furthermore, these six attributes collectively function to justify the financial capital needed to realise the model and to define a path to scale-up the business.

Based on its wide-ranging definitions, the business model thus has several elements. These elements cover a wide range of aspects, and there is a lack of consensus among scholars over the key components of a business model (Morris et al., 2005). However, the prevalent elements of a business model, as determined in the literature, can be categorised and summarised as follows:

- **Value proposition** (Alt and Zimmerman, 2001; Linder and Cantrell, 2000; Chesbrough and Rosenbloom, 2002; Weill and Vitale, 2001; Osterwalder, 2004), including *value stream* (Mahadevan, 2000), *customer value* (Afuah and Tucci, 2001), *value capture* (Stewart and Zhao, 2000), *value model* (Petrovic et al., 2001), *value offering* (Gordijn and Akkermans, 2001), *market offering* (Rayport and Jaworski, 2001), *products* (Horowitz, 1996; Dubosson-Torbay et al., 2001) and *product innovation* (Markides, 1999).
- **Revenue stream** (Mahadevan, 2000; Stewart and Zhao, 2000; Osterwalder, 2004; Brousseau and Penard, 2006; Rappa, 2010), including *revenue sources* (Timmers, 1998; Afuah and Tucci, 2001; Alt and Zimmerman, 2001; Weill and Vitale, 2001), *income* (Bonaccorsi et al., 2006), *revenue model* (Linder and Cantrell, 2000; Petrovic et al., 2001) and *sales* (Betz, 2002).
- **Cost structure** (Stewart and Zhao, 2000; Rappa, 2010; Chesbrough and Rosenbloom, 2002; Osterwalder, 2004; Bonaccorsi et al., 2006; Brousseau and Penard, 2006).
- **Pricing strategies** (Horowitz, 1996; Afuah and Tucci, 2001; Linder and Cantrell, 2000; Brousseau and Penard, 2006).
- **Customer segments** (Weill and Vitale, 2001; Osterwalder, 2004; Bonaccorsi et al. 2006), including *customer understanding* (Donath, 1999), *customer relationship* (Dubosson-Torbay et al., 2001; Petrovic et al., 2001), *customer interface* (Hamel, 2000), *customer orientation* (Alt and Zimmer-

man, 2001), *customer selection* (Stewart and Zhao, 2000) and *market segments* (Gordijn and Akkermans, 2001; Chesbrough and Rosenbloom, 2002).

- **Distribution channel** (Horowitz, 1996; Linder and Cantrell, 2000; Weill and Vitale, 2001; Osterwalder, 2004) including *products and services delivery* (Bonaccorsi et al., 2006).
- **Resources or capabilities** (Donath, 1999; Applegate, 2001; Afuah and Tucci, 2001; Hamel, 2000; Petrovic et al., 2001; Osterwalder, 2004), including *core technology/competencies* (Horowitz, 1996; Alt and Zimmerman, 2001; Rayport and Jaworski, 2001; Betz, 2002), *infrastructure management* (Markides, 1999), *governance* (Viscio and Pasternak, 1996; Amit and Zott, 2001), *competitive strategy* (Chesbrough and Rosenbloom, 2002) and *marketing strategy/tactic* (Timmers, 1998; Donath, 1999).
- **Network of partners or structure** (Alt and Zimmerman, 2001; Applegate, 2001; Dubosson-Torbay et al., 2001; Gordijn and Akkermans, 2001; Osterwalder, 2004; Bonaccorsi et al., 2006), including *business actors and roles* (Timmers, 1998).
- **Other components:** *profit stream* (Stewart and Zhou, 2000; Betz, 2002), *financial aspects/model* (Markides, 1999; Dubosson-Torbay et al., 2001; Rayport and Jaworski, 2001), *sustainability* (Afuah and Tucci, 2001; Rappa, 2010), *value chain positioning* (Chesbrough and Rosenbloom, 2002; Rappa, 2010), *value network* (Chesbrough and Rosenbloom, 2002), *legal issues* (Alt and Zimmerman, 2001), *network externalities* (Bonaccorsi et al., 2006; Brousseau and Penard, 2006), *capital model* (Petrovic et al., 2001; Betz, 2002), *production model* (Petrovic et al., 2001), *market model* (Petrovic et al., 2001), and *organisational characteristics/form* (Horowitz, 1996; Linder and Cantrell, 2000).

The above categorisations more or less fit with Morris et al. (2005), who found that the most frequently cited components were *value offering*, *economic model*, *customer interface/relationship*, *partner network/roles*, *internal infrastructure/connected activities* and *target markets*. They are aligned with Osterwalder's (2004) four pillars and nine building blocks of business model ontology: *product (value proposition)*, *customer interface (target customer, distribution channel, and relationship)*, *infrastructure management (value configuration, capability, and partnership)* and financial aspects (*cost structure and revenue stream*).

There is little previous research on the theoretical basis of business models. Amit and Zott (2001) proposed the business model construct as a unit of analysis on value creation in e-business. This construct was offered to enable the integration of several theoretical perspectives on value creation. Amit and Zott found that no single entrepreneurship or strategic management theory could fully explain the value creation potential of e-business at that time. In addition, Morris et al. (2005) argued that the business model construct was built upon central ideas in business strategy and its associated theoretical traditions, most directly upon the value chain concept (Porter, 1985) and the extended notions of value systems and strategic positioning

(Porter, 1996). The other related theories mentioned by Morris et al. (2005) were resource-based theory (Barney et al., 2001), strategic network theory (Jarillo, 1995), cooperative strategies (Dyer and Singh, 1998), choices about firm boundaries (Barney, 1999) and transaction cost economics (Williamson, 1981).

2.3.2 Business model taxonomies

Morris et al. (2005) agreed with Mahadevan (2000) that the largest volume of research about business models has been in electronic commerce (e-commerce). Early work focused on capturing revenue streams for web-based firms. Subsequent studies identified business model types based on product offerings, value-creating processes and firm architecture among other variables (Morris et al., 2005). Business model types/taxonomies have been categorised in many different ways. Rappa (2010) presented a taxonomy of business models that were observable on the web into nine basic categories, which include the following:

- **Brokerage model.** Buyers and sellers are brought together and transactions are facilitated. Brokers play a frequent role in business-to-business (B2B), business-to-consumer (B2C), or consumer-to-consumer (C2C) markets. Usually a broker charges a fee or commission for each transaction it enables. This model includes marketplace exchange (e.g. Orbitz, ChemConnect), buy/sell fulfilment (e.g. CarsDirect, Respond.com), demand collection system (e.g. Priceline.com), auction broker (e.g. eBay), transaction broker (e.g. PayPal, Escrow.com), distributor, search agent, and virtual marketplace (e.g. Amazon.com)
- **Web advertising model.** This model is an extension of the traditional media broadcast model. The broadcaster, in this case a web site, provides content and services mixed with advertising messages in the form of banner ads. The advertising model works best when the volume of viewer traffic is large or highly specialised. This model covers portal (e.g. Yahoo!), classifieds (e.g. Monster.com, Craigslist), user registration (e.g. NYTimes), query-based paid placement (e.g. Google, Overture), contextual advertising/behavioural marketing, content-targeted advertising (e.g. Google), in-tronmercials (e.g. CBS MarketWatch), and ultramercials (e.g. Salon in cooperation with Mercedes-Benz)
- **Infomediary model.** Some firms function as information intermediaries (infomediaries) to assist buyers and/or sellers in understanding a given market. This model comprises advertising networks (e.g. DoubleClick), audience measurement services (e.g. Nielsen/ Netratings), incentive marketing (e.g. Coolsavings), and metamediary (e.g. Edmunds)
- **Merchant model.** This model concerns wholesalers and retailers of goods and services. Sales may be based on list prices or through auction. This

model includes virtual merchants (e.g. Amazon.com), catalogue merchants (e.g. Land& End), click and mortar (e.g. Barnes & Noble), bit vendors (e.g. Apple iTunes Music Store)

- **Manufacturer (direct) model.** This model is predicated on the power of the web to allow a manufacturer (i.e., a company that creates a product or service) to reach buyers directly and thereby compress the distribution channel. The manufacturer model can be based on efficiency, improved customer service, and a better understanding of customer preferences (e.g. Dell Computer). This model consists of purchase, lease, licence and brand integrated content
- **Affiliate model.** This model provides purchase opportunities wherever people may be surfing by offering financial incentives (in the form of a percentage of revenue) to affiliated partner sites. The affiliates provide purchase-point click-through to the merchant. It is a pay-for-performance model. If an affiliate does not generate sales, it represents no cost to the merchant. The affiliate model is inherently well suited to the web, which explains its popularity. This model includes banner exchange, pay-per-click, and revenue sharing programmes
- **Community model.** This model is based on user loyalty. Revenue can be based on the sale of ancillary products and services or voluntary contributions; or revenue may be tied to contextual advertising and subscriptions for premium services. The internet is inherently suited to community business models and today this is one of the more fertile areas of development, as in the rise of social networking. This model includes open source (e.g. Red Hat), open content (e.g. Wikipedia), public broadcasting (e.g. The Classical Station/ WCPE.org), and social networking services (e.g. Facebook, Twitter and Instagram)
- **Subscription model.** In this model, users are charged a periodic . daily, monthly or annual . fee to subscribe to a service. It is not uncommon for sites to combine free content with "premium" (i.e., subscriber- or member-only) content. Subscription fees are incurred irrespective of actual usage rates. Subscription and advertising models are frequently combined. This model includes content services (e.g. Netflix, Listen.com), person-to-person networking services (e.g. Classmates), trust services (e.g. Truste), internet services providers (e.g. America Online)
- **Utility or on-demand model.** This model is based on metering usage or a "pay-as-you-go" approach. Unlike subscriber services, metered services are based on actual usage rates. Traditionally, metering has been used for essential services (e.g., electricity water, long-distance telephone services). Internet service providers (ISPs) in some parts of the world operate as utilities, charging customers for connection minutes, as opposed to the subscriber model common in the U.S. This model includes metered usage and metered subscription

Other attempts to construct business model taxonomies were presented by Timmers (1998), Tapscott et al. (2000), Linder and Cantrell (2000), Applegate (2001), Weill and Vitale (2001) and Libert et al. (2014). Timmers (1998) distinguished between 11 generic e-business models and classified them based on their degree of innovation and their functional integration (Figure 10). Tapscott et al. (2000) proposed a network and value-centred taxonomy that distinguished between five types of value networks called business webs (b-webs), which included agora (e.g. eBay), aggregation (e.g. Amazon.com), value chain (e.g. Dell), alliance (e.g. Linux), and distribution network (e.g. FedEx). They further positioned these b-webs according to the level of economic control (hierarchical to self-organising) and value integration (low to high). Linder and Cantrell (2000) categorised business models as price models, convenience models, commodity-plus models, experience models, channel models, intermediary models, trust models, and innovation models. Applegate (2001) identified four types of digital business models: focused distributor models (e.g. retailer, marketplace, and infomediary), portal models (e.g. horizontal portals, vertical portals, and affinity portals), producer models (e.g. manufacturer, service provider, and custom supplier), and infrastructure provider models (e.g. infrastructure portal). Weill and Vitale (2001) proposed eight atomic e-business models, including content provider, direct to customer, full-service provider, intermediary, shared infrastructure, value net integrator, virtual community and whole-of-enterprise/government. Libert et al. (2014) introduced four different business model categories, including asset builders (e.g. Ford, Wal-Mart, and FedEx), service providers (Accenture and JP Morgan), technology creators (e.g. Microsoft and Oracle), and network orchestrators (e.g. eBay, Uber, Tripadvisor and Alibaba).

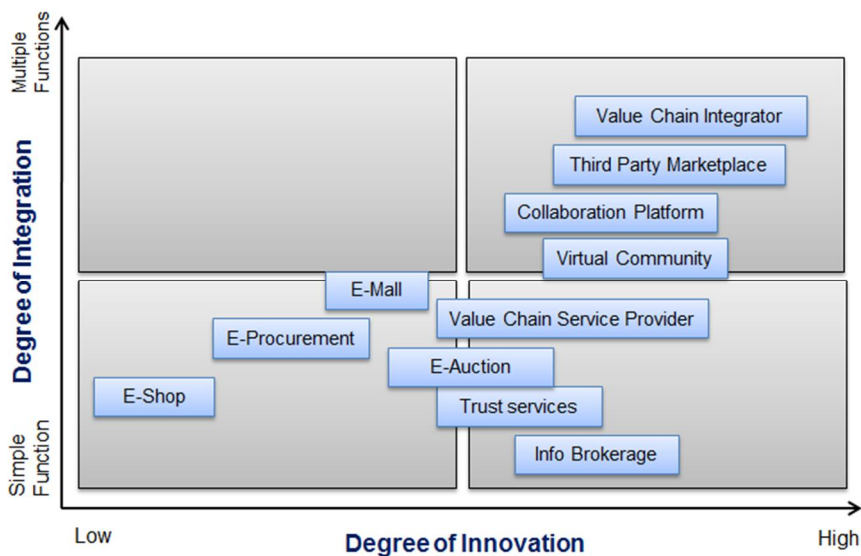

Figure 10. Timmers (1998) business model taxonomy

2.3.3 Business model evaluation and evolution

Morris et al. (2005) argued that the lack of a consensus in the definition of a business model and its key components inhibited progress in several related issues, such as the conditions that make a particular model appropriate, ways in which models interact with organisation variables, existence of generic model types, and dynamics of model evolution. Limited progress also has been observed in establishing methodologies for evaluating model quality. Several studies that evaluated the business model include Hamel (2000), Afuah and Tucci (2003), Gordijn and Akkermans (2003), and Di Valentin et al. (2012).

Hamel (2000) proposed four questions/indicators to evaluate the wealth potential of a business model: 1) To what extent is the business concept efficient in delivering benefits for customers? 2) To what extent is the business concept unique? 3) What is the degree of fit among the elements of the business concept? 4) To what extent does the business concept exploit profit boosters?

Afuah and Tucci (2003) suggested three appraisal levels to measure the effectiveness of a business model: *profitability measures* (earnings and cash flow), *profitability predictor measures* (margins, market share, and revenue share growth rate) and *business model component attributes* (positioning, value, scope, price, revenue, activities, implementation, capabilities, sustainability, and cost structure).

Gordijn and Akkermans (2003) proposed a framework called the e³-value method to explore an innovative e-commerce idea with the aim of understanding it thoroughly and evaluating it for potential profitability, which means evaluating the business model. They proposed a quantitative approach to study the economic feasibility of an e-business idea by following three steps: 1) creating profitability sheets for each actor involved in the value model; 2) asking actors to assign economic value to objects delivered and received; and 3) using evolutionary scenarios to determine effects of expected changes in the future that influence the profitability.

Di Valentin et al. (2012) conducted a study to gain insight into how firms currently measured the quality of their business models. The study focused on the existing dependencies between business models and business processes, as business models are often seen as mediators between a firm's strategy and its business process. There was no standardised framework in the literature or in practice to support key performance indicators (KPIs) from business processes on business models and vice versa. However, they argued that this aspect could be essential for an enterprise to be able to analyse, define and adapt its current business model to internal or external environmental factors. The study found some relevant KPIs for business model adaptations.

Another aspect of business models is the dynamics of its change or evolution. Although business models are static by nature and simply take a snapshot of a current situation, several scholars added a time trajectory to them and introduced the concept of change (Osterwalder, 2004). The concept of change in business models is relevant because of the numerous pressures in the firm's environment, such as technology, law, and competition (Linder and Cantrell, 2000). Therefore,

several studies have been conducted to determine the change aspects of business model (Linder and Cantrell, 2000; Tapscott et al., 2000; Petrovic et al., 2001; Papakiriakopoulos et al., 2001). Table 4 summarises these studies.

Table 4. Summary of concepts of change in business models

Studies	Business model change concepts
Linder and Cantrell (2000)	Introduced <i>change models</i> and distinguished them into four types according to their degree to which they change the core logic of a company, i.e. <i>realisation model</i> , <i>renewal model</i> , <i>extension model</i> and <i>journey model</i> .
Tapscott et al. (2000)	Proposed six steps of change methodology in creating a b-web company, including 1) describing the value proposition, 2) disaggregating and identifying the total value-creation system entities, 3) envisioning b-web enable value, 4) re-aggregating the company, 5) preparing a value map, and 6) conducting the b-web mix.
Petrovic et al. (2001)	Introduced double-loop learning to explicit mental model through a systematic business model concept. This will provide a holistic, long-term, and dynamic view that helps in redesigning business models.
Papakiriakopoulos et al. (2001)	Proposed a transformation method for constructing e-business models. It included four steps: 1) defining scope and context, 2) drawing the relationships and flows between the actors, 3) identifying the nature of competition in the marketplace, and 4) constructing a feedback chain.
Gordijn and Akkermans (2003)	Outlined a change methodology based on value model deconstruction and reconstruction. The process was divided into two questions, i.e. which value-adding activities exist and which actors are willing to perform these activities

2.4 Theoretical synthesis and reflections

As formulated in the previous section, the main research objective of this dissertation is to understand the transport system under technological change through identifying the characteristics of the market, business ecosystem, and business model. To support the research process, the associated theoretical foundations should be understood in order to facilitate the analysis.

Hence, the literature on market research and analysis, business ecosystems, and business models provide the theoretical background required to achieving the

objective of this dissertation. This section synthesises the existing theories and the definitions of the key concepts. The theoretical framework used in this dissertation is illustrated as the a-priori model (Figure 11) and the relevant theories are examined (Table 5).



Figure 11. The a-priori model in a theoretical framework

Market research and analysis can be defined as the systematic gathering and interpretation of information about individuals or organisations using the statistical and analytical methods and techniques of the applied social sciences to gain insight or support decision-making (ICC/ESOMAR, 2008). As part of the research process in this dissertation, understanding the transport market will be crucial for both business decision makers and public policy makers in the transport sector. Understanding the market will provide business planners with the right knowledge when they want to design a viable business model to help companies survive the competition. In addition, understanding the market will also help policy makers construct the best transport policy instruments to better serve the society. Moreover, the market context will be useful as the basis of discussing and analysing the business ecosystem as well as designing and developing a business model.

The business ecosystem entails a new perspective on viewing the business collaboration or network by applying the biological term of the ecosystem. The busi-

business ecosystem can be defined as those networks . of suppliers, distributors, outsourcing firms, makers of related products or services, technology providers, and a host of other organisations . that affect and are affected by the creation and delivery of a company's own offerings+ (Iansiti and Levien, 2004). The research examines the transport system as an ecosystem under technological change. This will provide some interesting and useful insights for both academics and practitioners in the transport sector in understanding the phenomena, especially when they want to focus on the relationships among the stakeholders and emphasise the dynamics within the ecosystem.

The definition of the *business model* varies among scholars. There is no consensus to define the business model comprehensively. However, for the purpose of the dissertation, the author follows Osterwalder (2004), who defined a business model as "a conceptual tool that contains a set of elements and their relationships and allows expressing a company's logic of earning money. It is a description of the value a company offers to one or several segments of customers and the architecture of the firm and its network of partners for creating, marketing and delivering this value and relationship capital, in order to generate profitable and sustainable revenue streams." (p. 15). With regard to the dissertation, applying the business model as a unit of analysis will obviously enrich the understanding of the transport system under technological change. In addition, the business model can be also a worthwhile aspect to be analysed in a business ecosystem, especially when the researcher aims to understand the dynamics or characteristics of a company's business model in order to gain a competitive advantage within or outside the ecosystem. Figure 11 illustrates the theoretical framework used in this dissertation.

Finally, Table 5 shows the relations between the research questions, the research strategies and the theoretical foundations of this research.

Table 5. Theoretical reflections on the research

Research questions	Key concepts	Main references
<p>RQ1</p> <p><i>What are the characteristics of the market in the context of technological change in transport sector? How do the market environment, size, trend and structure prominently figure, and what do they imply?</i></p>	<p><u>McQuarrie's fundamental mode of market research:</u></p> <ul style="list-style-type: none"> • Exploratory <p><u>Mittal's framework:</u></p> <ul style="list-style-type: none"> • Descriptive research (survey & secondary data) <p><u>Brown's market analysis categorisation:</u></p> <ul style="list-style-type: none"> • Qualitative market analysis (EV case study) • Quantitative market analysis (ITS case study) 	<p>McQuarrie (2005), Mittal (2015), Brown (2008), Xu (2005).</p>

	<ul style="list-style-type: none"> • National market analysis (ITS case study) • Market trend analysis • Sales analysis <p><u>Xu's market measures:</u></p> <ul style="list-style-type: none"> • Market environment • Market size • Market growth rate • Market share (ITS case study) • Market concentration (ITS case study) 	
<p>RQ2</p> <p><i>What are the characteristics of business ecosystem in transport system under technological change? Who are the key stakeholders and what are their roles and functions within the ecosystem? How do they build the relationships and how have the dynamics happened there?</i></p>	<ul style="list-style-type: none"> • Moore's four evolutionary stages in a business ecosystem (BE) • Gossain and Kandiah's concept to recognise the importance of value creation in a BE • Iansiti and Levien's three critical measures on BE healthiness and four different strategies • Smith's risk identification in BE and six types of BE 	<p>Moore (1993), Gossain and Kandiah (1998), Iansiti and Leiven (2004), Smith (2013).</p>
<p>RQ3</p> <p><i>What are the characteristics of business model in the emerging transport systems as the result of technological change? How can different business model topologies and options be examined and evaluated? What kind of strategy could be approached for designing a viable business model in the emerging transport system?</i></p>	<ul style="list-style-type: none"> • Business model components • Business model taxonomies • Business model evaluation • Business model evolution 	<p>Zott et al. (2011), Morris et al. (2005), Chesbrough and Rosenbloom (2002), Osterwalder (2004), Rappa (2010), Timmers (1998), Linder and Cantrell (2000).</p>

3. Research contribution

This chapter consists of three sections: the summary of the previously published articles; the research findings and answers to research questions; and the synthesis of the results. In the first section, the summary of each appended article as an empirical contribution to this research is presented. The research contributions are then summarised in the second section. Finally, all results are synthesised and represented in a single conceptual framework that is used to explore and understand the phenomena, which is discussed and presented in the last section.

3.1 Summary of articles

3.1.1 Article I: Electric vehicles market outlook – potential consumers, information services and sites test.

This article reports the study of current market activities and offerings of EVs based on reviewing the most recent and relevant business intelligence and market research reports. Reflecting Mittal (2015), this study is descriptive in nature, as the knowledge richness is relatively moderate and its managerial purpose is likely to describe the market. It also relies on secondary research and a literature review as the research method. Market information and insights gained from both scientific literature and market reports are mainly utilised to construct a general understanding of the global EV market, which contains information about the market growth and forecast, business model options, and market survey results regarding consumer aspirations. The latter are prominently discussed in the article, which describes the market environment including discussion on the drivers and inhibitors of EV market acceptance. Furthermore, to enrich the analysis, a particular discussion on information services development for EVs and some test sites around the globe are addressed.

The future global EV market is seen to have promising market growth potential although the business models that could meet consumer aspirations are still lacking. Consumer concerns about the high cost of EVs, the battery range and reliability and the infrastructure. The study also points out the involvement of new actors outside the automotive industry, such as the utilities and the charging manufacturers and the need for a new kind of cooperation model in the EV ecosystem.

The growing potential of the EV market has stimulated the development of several services, such as information services, to support the EV deployment. The article examines information services development as the result of offerings provided by the automotive manufacturers. This development will also bring an opportunity for the ITS industry actors to collaborate and take part in the EV deployment.

In the current development of EVs, there is an increasing need to ensure the seamless operation of infrastructure and demonstrate the experiences of end users. EV test sites are established and promoted in many countries and regions around

the globe. The emerging EV test sites generally involve the collaboration of several actors, including automotive manufacturers, utilities companies, services providers, research organisations and city authorities.

The article lists 15 test sites around the world, most of which are in the US and Europe. However, these are examples because the article shows that in China 13 cities are piloting EVs (Zheng et al., 2012). The total growth projection for global EV markets varies according to different sources, and even the projections adopted in the article from reference sources (Frost & Sullivan, 2010) have different scenarios. Frost & Sullivan (2010) predicted that by 2020, the global sales of EVs will comprise 4% to 12% of total car sales. The master driver of the test sites seems to be the automotive industry, in addition to energy utilities and battery suppliers. Each of these was identified to have strong strategic business interests.

3.1.2 Article II: The size, structure and characteristics of Finland's ITS industry

This article reports the first quantitative and empirical analysis of the ITS industry in Finland. The study aims at delivering critical information to several stakeholders, such as Finnish industry policy makers and ITS business developers to clarify their perceptions of the ITS industry in Finland. Through its analysis, tools and approaches, the study also attempts to quantify the foundation of expectations and hence shed light on a realistic view of the industry.

The paper examines the ITS industry structure from the supply side, which consists of companies that deliver ITS products and services. The industry structure is distinguished according to the nationality of the company, the firm's position in supply chain and the firm's size. The study evaluates several market indicators and measures (Xu, 2005), such as market size, market growth, market concentration and market share. Another characteristic examined in the study is the effect on employment in the ITS industry. The Finnish stock market indices (IT and telecommunication sector) and the GDP of Finland are also utilised to enhance the analysis in the study.

The size of the market is determined by calculating the aggregate supply (i.e. sales/turnover) of the companies. The data were gathered from annual statements that are available from several sources, such as company websites, public databases and direct information. The market growth is calculated from a selected sample of companies that provide 100% of ITS products or services, so that the noise from non-ITS growth (i.e. companies that have several other business segments in addition to ITSs) could be avoided, thus ensuring the validity of the results. In measuring the market concentration, the Herfindahl index formula is particularly employed in addition to descriptive statistics.

In 2010, the Finnish ITS market size was approximately " 300 million (~0.17% GDP Finland), of which not less than 72% comprised local (Finnish) companies, with around 1700 employees. In 2007, the market had significant growth but was very slow in 2008 and 2009. However, the market growth is promising compared to

GDP growth and the Finnish share indices for the IT and telecommunication sector. Because the market concentration is relatively low, non-monopolistic and non-oligopolistic, the market seems to be fairly competitive. Service providers have a relatively dominant position (56% market share), followed by equipment providers (33%) and application providers (11%). Regarding the firm size, the industry composition is dominated by medium-sized and small-sized companies.

The article further discusses the implications of the Finnish ITS market figures for industrial policy and business strategies. The first concern regarding the sluggish ITS market growth is associated with the dominant role of consultancies that are offered to the public sector. This is not a good signal for building the industrial base in the country because of the long-term effects and employment capacity of the industry. Another weak signal for Finland is the servitisation of industries. Unless there is a strong equipment and hardware manufacturing base in the country, there will be fewer opportunities to create a domestic service sector in addition to the manufacturing sector.

The study concluded that although the Finnish ITS industry has an important role, it is not entirely on the growth path of global projections. The reasons are explained by the market characteristics that imply the following:

- a) The lack of key players with enough strong business interests (e.g. the automotive cluster)
- b) The dominance of service providers in the form of consultancies, leading to the lack of a technology push.

3.1.3 Article III: The Finnish road weather business ecosystem – turning societal benefits into business and the other way round

The purpose of this study is to model and investigate the winter road weather and maintenance ecosystem in Finland. The model describes the roles and functions of stakeholders and their value network. The model is further analysed based on value analysis and value theory to evaluate the current ecosystem. The value model describes the philosophy of ecosystems in providing services that have value to the users by combining their resources and functions. Resources could be understood as costs of delivering a function, technologies, capabilities, market presence, distribution networks, and so forth. Different functions (service and product offerings) of the ecosystem stakeholders in a value network are distinguished, and the end-user value, which becomes a socio-economic benefit that justifies performing the functions in the ecosystem, is discussed. Both supply and demand side approaches are adopted in this study. As discussed in the article, the policy changes in infrastructure management (shifting of responsibility to private sector) and the technology forces could lead the ecosystem to become unstable because they affect the environment in which they operate.

The current ecosystem model of the Finnish winter road weather and maintenance system (Figure 12)⁴ is described using customer value chain analysis (CVCA). To enhance and co-create value, the joint development of the ecosystem was determined to be the best value-capturing strategy. In the existing ecosystem, five ecosystem stakeholders had realised the potential of carrying out some joint development activities: *meteorological observation device manufacturer; maintenance equipment manufacturer; vehicle location, measurement and tracking solutions provider; meteorology and observation device manufacturer; and road weather and conditions forecast provider*. The overall idea is to enhance the development of a next-generation decision-support system (DSS) that would offer accurate road weather and condition information, thus helping the decision-support service provider to deliver better information and recommendations to road maintenance service operators.

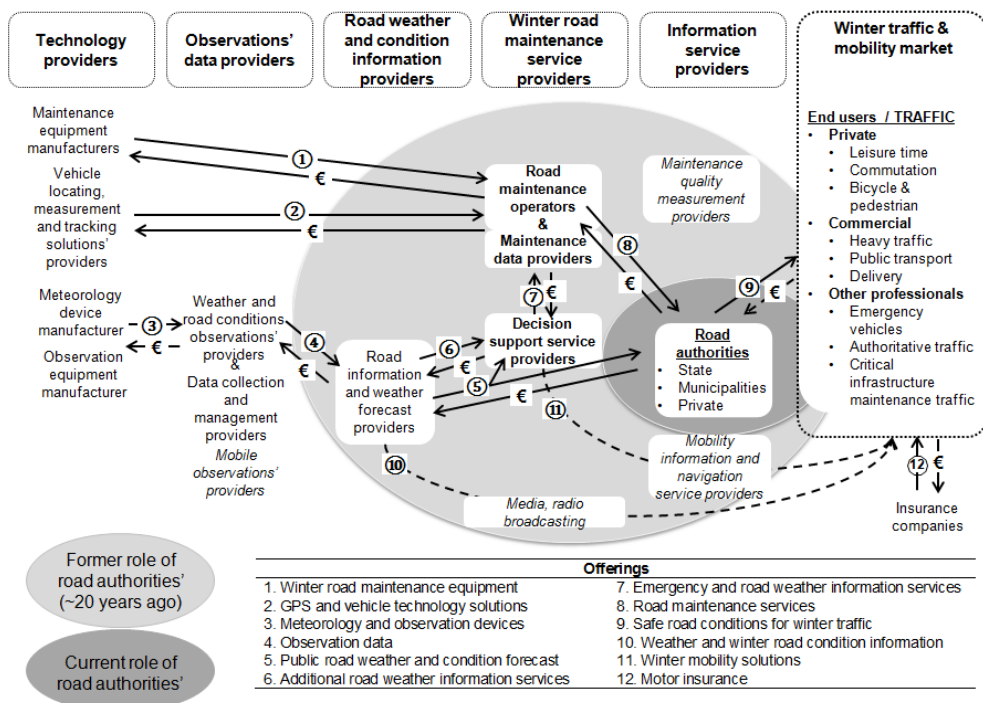

Figure 12. The current Finnish road weather and maintenance ecosystem model (modified from Leviäkangas et al., 2015; Pilli-Sihvola et al., 2015)

⁴ The current Finnish winter road weather and maintenance ecosystem model studied in the article has been developed. The next version of the model was presented in Leviäkangas et al. (2015) and Pilli-Sihvola et al. (2015).

Four postulates are offered as conclusions in the article:

- *Business ecosystems are vital in order to deliver not only market-demanded services but also services that are regarded as societal and public.* This means that clients procuring public services, such as winter maintenance, have a key role because they define the market.
- *Even small firms that have unique capabilities (offerings) can have a key role in a business ecosystem.* This means that the public client can encourage small innovative firms to become integral parts of business ecosystems through supportive public procurement practices and processes.
- *The capabilities of ecosystems define the service levels and societal gains.* In other words, if business ecosystems are unsuccessful in their composition, strategic collaboration and integration of capabilities into value-adding service bundles, the society could lose benefits that might otherwise be potentially realisable.
- *The emergence and success of ecosystems is a dynamic process requiring a multifaceted responsiveness.* This means that collaborative networks, both of official and unofficial, must be put to work in order to pave the way for the emerging business ecosystems. In addition, procurement policies and contract protocols are factors that can hinder or support the prospects of business ecosystems.

3.1.4 Article IV: The electric vehicles ecosystem model – construct, analysis and identification of key challenges

This study conducts a review of the literature on several key aspects of EVs. These aspects are clustered into four different themes: 1) consumer and market views to EVs; 2) EV policy deployment and impacts; 3) business models and regulatory framework; and 4) environmental issues related to EVs. The study then discusses the key challenges that are faced during the EV deployment. The challenges are reviewed based on the literature and are clustered into three major groups: consumer acceptance challenges, technical challenges, and environmental challenges (Figure 13). The consumer acceptance challenges concern the consumers. They are divided into price, infrastructure, EV performance and other concerns. The technical challenges include the battery, charging infrastructure, the vehicles, and standardisation issues. The latter challenges are related to environmental issues and policy aspects, including battery recycling, power supply infrastructure and incentive policies.

The most important issues regarding the market penetration of EVs are associated with infrastructure readiness (the supply grid), the maturity of technologies (EVs, batteries and power sources), and consumer aspirations (mainly price). Technology issues should be solved first. The technology must be mature enough to have the right price in the eyes of consumers. Furthermore, the support by public

innovation policy, especially through providing the research funding for technology development, seems to be important in accelerating the deployment of EVs.

The study also identifies the key roles and functions of the stakeholders in the EV ecosystems. The conceptual model of an EV ecosystem (EVE) is constructed, and the relationships between key stakeholders are examined using an EVE stakeholders-relationship matrix. The automotive manufacturers and the regulators seem to be the key actors in the ecosystem. The battery suppliers seem to fit the role of value-adding dominator although the dominance potential is restricted. The utilities providers have strategic expansion potential, as does the automotive sector, and they have equally dominating roles. Both have the potential to reduce the challenges to consumer acceptance.

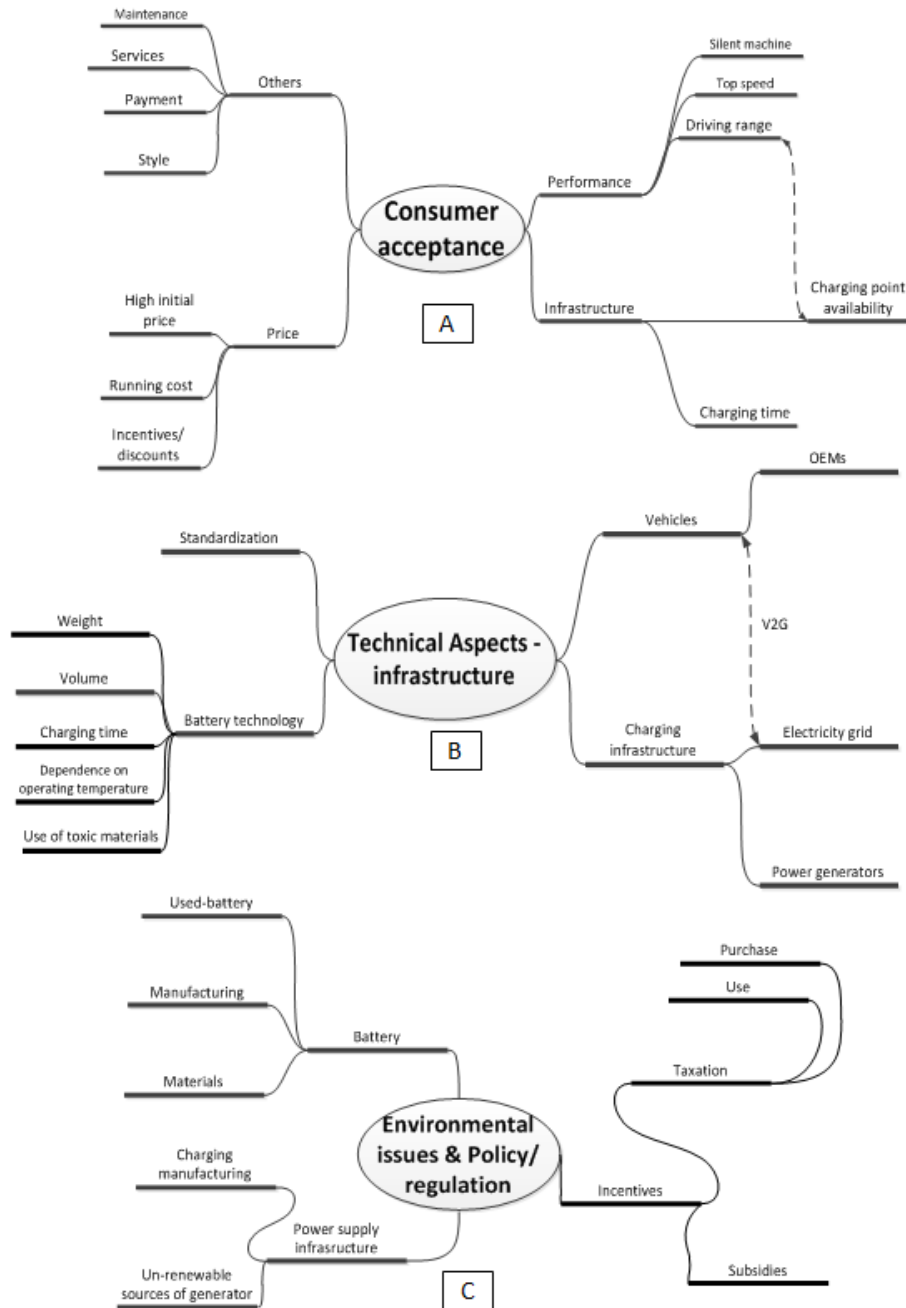

Figure 13. Key EV challenges: A) Consumer challenges; B) Technical challenges; C) Environmental & policy challenges (modified from Article IV)

As new actors in the ecosystem, the integrators are in a good position to address the technical challenges because they occupy the middle position among the stakeholders. However, they need to be supported by the key stakeholders, which are the EV manufacturers, in order to have some control over the market. This can be reached either by the EV manufacturers pursuing the integrator role themselves or through a jointly owned integrator mechanism. Furthermore, business model compatibility among ecosystem actors is an obvious prerequisite to creating synergies and to paving the way towards a common market platform.

3.1.5 Article V: Business model evolution for ITS services

The study examines the existing ITS services business models. Based on these models, the study then investigates the traditional and modern versions of a generalised business model framework. Several types of existing business models are found in advanced traffic information services (ATIS), such as the public-centred model, contract-based mutual system model, franchised-based operation model, and private sector competition model (Choi et al., 2001). Burgess et al. (2007) further supplemented the list by including the value-added resellers and business-to-business model.

Based on these existing business models, the article presents the traditional business model topology framework for ITS services. The model is conventional because it relies on the value chain. The actors in the value chain tend to focus on their own roles by providing the products or services to their downstream actors. The flow of money and offerings seem to be straightforward.

The changes in environment, such as the dynamics of technology, market and regulation, calls for evolving business models in every firm. Traditionally, processing data into a meaningful format was done by software installed on a device. However, with the help of the current internet access, the processing can be outsourced to a cloud computing service. Therefore, the modern business model will be more flexible and open than the traditional model is. In the modern business model, a single company can focus not only on one role but also on more functions in the value chain. In contrast, multiple can fulfil one role. This can also enable the company to expand to other markets by adjusting the strategic focus and using resources more effectively. To illustrate the characteristics of the modern business model framework, a morphological analysis method (the tool used is the morphological box diagram) is utilised. This framework would be used as the basis for describing the business models/topologies in other applications (e.g. within a particular business ecosystem).

3.2 Research findings and answers to research questions

This section discusses the results and synthesises them by finding logical links between them, which is an outcome of the research conducted for this dissertation. The results are related to the research questions and the related theories. Figure

14 illustrates the relation of the research results to the research questions and to the related theories. The answers to the research questions are discussed and summarised. The findings are highlighted as initial insights into what happens in the so-called transport system under technological change+phenomena.

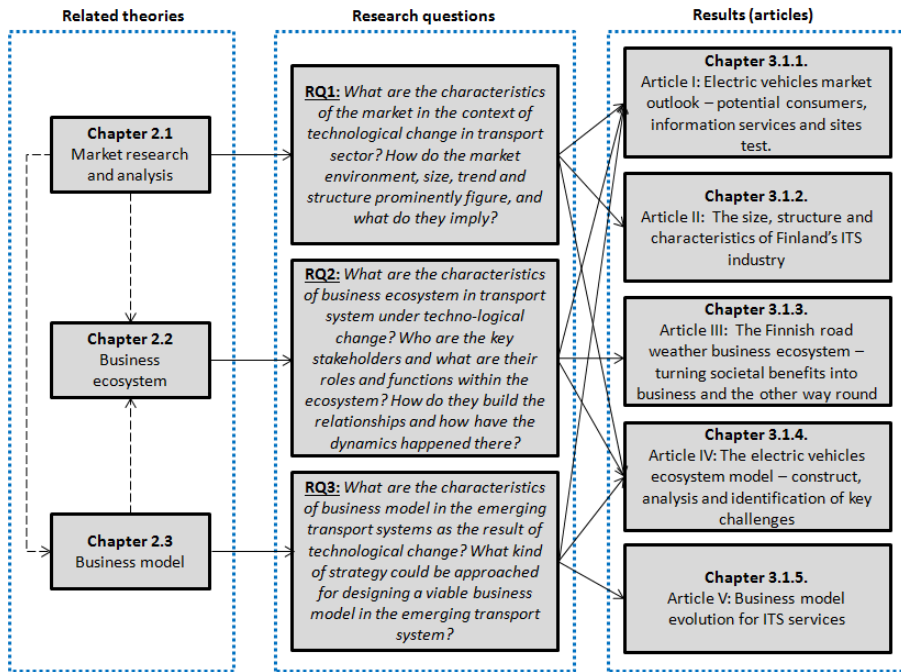

Figure 14. Links between theories, research questions, and articles

As illustrated in Figure 14, the answers to the research questions were retrieved from the articles according to their topics. Article I, Article II and Article IV are the main empirical sources used to answer RQ1 (market viewpoint), whereas the answer to RQ2 (business ecosystem viewpoint) was mainly derived from Articles III, IV and I. Lastly, Article V, Article IV and Article I were the sources used to answer RQ3 (business model viewpoint).

In the following section, based on the findings, the answers to the research questions are discussed and summarised.

RQ1: What are the characteristics of the market in the context of technological change in transport sector? How do the market environment, size, trend and structure prominently figure, and what do they imply?

To answer RQ1 about the *market viewpoint* in transport systems under technological change, the main empirical findings reported in Articles I, II and (partially) IV were employed. Article I and Article IV provided the first insights into the market characteristics, especially in electro-mobility systems. The most notable findings concerned the EV market environment. According to Xu (2005), the market environment *consists of the actors and forces outside the organisation that affect the management's ability to build and maintain relationships with target customers. It is divided into three layers: internal environment (inside the company); micro-environment (company, suppliers, marketing intermediaries, customers, competitors, and publics); and macro-environment (demographic, economic, natural, technological, political, and culture)*. The study conducted in Article I covers several aspects of the existing EV market environment (particularly the macro-environment), which focus on the EV market demographic, consumers' behaviour and their aspirations regarding EVs, which were sourced from business intelligence or market research reports. The consumer aspirations aspect was also presented in Article IV as the results of several literature reviews primarily of peer-reviewed articles. The retrieved information was then interpreted and utilised as empirical findings to construct a hierarchical model of consumer acceptance challenges.

In addition to the market environment, Article I examined the market size and the market growth of EVs. Although they were not examined deeply because of the limited access to detailed information about secondary research results, market size and trend figures can be used as an initial knowledge to gain insight. Furthermore, the current EV market activities, which emphasised digital information services offerings and EV test sites, were also investigated in Article I.

Based on the empirical findings, the EV market characteristics are described as follows:

1. *The EV market is still in its infancy, but it likely possesses great potential for acceptance by the market in the future.* Although there are no certain estimates about when EVs will be fully deployed or will substitute the use of conventional vehicles (CV), several market reports attempted to estimate it by using the market trend/growth approach, which uses the percentage of EVs sales relative to the CVs as the indicator. Frost & Sullivan (2010) predicted that by 2020, global sales of EVs would comprise 4% to 12% of total car sales. In addition, a market report from Finpro (Vardera, 2010) estimated that the EV market size varied from 1% to 25% of total car sales by 2020 in the US.
2. *The main challenges in terms of consumer market acceptance are mainly price (or total cost of ownership, to be exact), followed by EV performance (e.g. range anxiety) and infrastructure readiness (e.g. charging points convenience and charging time).* These aspects are usually known as key inhibitors of EV adoption. In contrast, environmental benefits, reduced fuel cost, green and tech-savvy images (eco-trendiness) are seen as several key drivers of adoption.

3. *The EV market demographic remains unclear depending on the geography area.* For example, in North America, early adopters are mainly females in suburban areas, aged between 36 and 45 years and interested in luxury cars. Whereas in Europe, EV adopters are predominantly aged 26. 35 years and above and 55-year-old males with high disposable incomes.
4. *The emerging development of digital information services for EVs could improve their performance and user experience, hence accelerating EV penetration.* This development will open a new business potential that is especially associated with another emerging sector in transport, namely ITS.
5. *The growing trend of EV test sites in demonstrating the vehicles, infrastructures, and operations around the globe will catalyse the EV campaign and promotion activities.* Because consumers need to gain experience with the EV, so that perceived negative aspects such as price or range can be opposed by some positive experiences in everyday usability, as indicated by Hanke et al. (2013).

The second case study from this market perspective is the Finnish ITS market study reported in Article II. Unlike the EV market study, this study is a primary market research, quantitative in nature and a national (country-specific) market analysis in scope. It relied on both primary (survey or direct information) and secondary empirical data (publicly available materials) that focus on the sales/turnover and employee figures of ITS companies in Finland. The data were then processed and analysed using descriptive statistics, the Herfindahl index, the Finnish stock market index, and micro-economics principles.

The study includes several market characteristics, such as the market/industry structure (market composition and market share), market size, market trend and market concentration. The effect of the market on employment is particularly examined. The following findings describe and summarise the Finnish ITS market characteristics:

1. *The Finnish ITS market structure is dominated by local (Finnish) companies, small and medium-sized companies, and relatively dominated by service providers.* Other sectors in the Finnish ITS supply chain comprise equipment providers (33% market share) and application providers (11% market share).
2. *The size of the Finnish ITS market was approximately " 300 million and around 1,700 employees in 2010.* This figure contributes about 0.17% of the GDP of Finland, which is considered correct, especially when compared with Ezell (2010). It certainly serves industrial policy making if such policies are considered with regard to ITS.
3. *The ITS market in Finland had a significant growth in 2007 but since then has been sluggish in turning upwards from the negative growth observed in 2008 and 2009.* However, compared with the GDP trend and the Finnish

stock market indices in IT and telecommunication sector in the same time span, the Finnish ITS market growth is promising.

4. *The Finnish ITS market was found to unconcentrated (Herfindahl index below 0.15), and no monopolistic or oligopolistic features were observed. The market seems to be fairly competitive although a moderate concentration existed within the same segment of the industry value chain (especially service providers and application providers), and a relatively high concentration was apparent for equipment providers.*
5. *The global ITS market characteristics (retrieved from secondary research) were also examined, and they were promising in terms of size and general trend.*

The empirical sets of postulates derived from the case studies were used to answer RQ1. However, because both cases exist simultaneously in the transport system under technological change, several commonalities were observed and general answers to RQ1 were derived. The common, general and inductive answers to RQ1 are formulated as follows:

The market characteristics of transport systems under technological change seem to be in their infancy, immature, and heading towards a wide scale of penetration, yet they are still promising and obviously require particular efforts to gain customers/end users awareness and acceptance, through support by governments and other key stakeholders by providing initiatives, incentives and demonstration activities.

RQ2: What are the characteristics of business ecosystem in transport system under technological change? Who are the key stakeholders and what are their roles and functions within the ecosystem? How do they build the relationships and how have the dynamics happened there?

RQ2 was formulated to view the phenomena as a business ecosystem. The main findings from Articles IV, I and III were utilised to answer RQ2. The results of the studies reported in Article IV and (partially) Article I contributed to identifying the characteristics of the business ecosystem in electro-mobility system (EVE). In Article I, the initial simplified EV ecosystem model is introduced as retrieved from secondary research. In Article IV, first the key challenges in the EV ecosystem are identified and clustered into three different themes. The key stakeholders in the EV ecosystem are then identified, and their roles and functions are examined. Finally, the relationships between the stakeholders are investigated using the stakeholders relationship matrix, and the model of the EV ecosystem is constructed. The following summarises the findings of the case study of the EV ecosystem:

1. *The key challenges in the EV ecosystem are clustered into three themes: 1) consumer acceptance challenges; 2) technical aspects (infrastructures) challenges; and 3) environmental challenges and policy/regulatory issues.* Consumers still have some questions that call for answers before they are ready to adopt EVs (e.g., regarding price, performance, infrastructure etc.). Regarding technical aspects, some challenges are issues with battery technology, vehicles, charging infrastructure, and standardisation. Regarding environmental challenges, the battery life cycle, the manufacturing process, and the materials used in the manufacturing process are some identified concerns, whereas taxation and incentive strategies were notable issues in policy.
2. *The key stakeholders in the EV ecosystem comprised EV end users, power utilities and infrastructures (PUI), EV manufacturers (EVM), battery suppliers (BS), regulators and external actors (REA), and EV aggregators/integrators (EVAI).* Some other relevant actors that might be considered as part of the EV ecosystem were battery recycling companies, vehicle testing service providers, used car dealers, telecommunication service providers, insurance companies and investment/finance institutions.
3. *The key stakeholders relationships were examined through the EVE stakeholders relationship matrix (see Article IV, p. 271, Table 2). The EV ecosystem model was constructed (see Article IV, p. 268, Figure 4).*
4. *The main driver of EVs seems to be the automotive industry. The other actors are the battery suppliers (value-adding dominator) and energy utilities, especially those who own their networks in addition to production facilities. Both the automotive and the utilities sectors have a strategic expansion potential in the value network of the EVs, and they can have equally dominating roles.*
5. *The EV manufacturers and the regulators are in a key position.* With the support of these two actors, the ecosystem can exist.
6. *The integrators seem to have a good position to address technical challenges by being in the centre of the stakeholders.* Their proactive role might have a good boosting effect on EVE's growth. Nevertheless, if they move too early, the EV manufacturers could easily inhibit these efforts.
7. *The new potential actor in the EVE is the mobility services/digital information services provider.* This actor will provide in-vehicle system services that will improve users' convenience in driving their EVs, which can boost the EV penetration in the long run.

The results reported in Article III were used in another case study of a business ecosystem, that is, the Finnish road weather and maintenance ecosystem. A relatively similar approach was utilised in this study. The key stakeholders and their roles and functions were identified. The key stakeholders' relationships were then investigated and represented in a model using the CVCA tool. Finally, the potential

value-capturing strategies for the Finnish road weather and maintenance ecosystem were discussed. The following summarises the findings of the study reported in Article III.

1. *The key stakeholders in the Finnish road weather and maintenance ecosystem were identified, and their roles and functions in the ecosystem were examined (see Article III, p. 62, Table 1).*
2. *The relationships among stakeholders within the ecosystem were initially illustrated in Article III (p. 61, Figure 2). The next version of the ecosystem model was further developed and published in Leviäkangas et al. (2015) and Pilli-Sihvola et al. (2015). The modification of the next version model is depicted in Figure 12.*
3. *To enhance and co-create the value in the ecosystem, the joint development of the ecosystem was found to be the best value-capturing strategy. In the existing ecosystem, five stakeholders (i.e. meteorological observation device manufacturer; maintenance equipment manufacturer; vehicle location, measurement, and tracking solutions provider; road condition device manufacturer; and road weather and conditions forecast provider) were found to have the potential to conduct joint development activities. An obvious example for this is enhancing the development of a next-generation DSS that offers accurate and the most recent information on road weather and conditions.*

Both the EV ecosystem and the Finnish road weather and maintenance ecosystem case studies contributed the empirical findings used to answer RQ2. Similar to the answer to RQ1, every point summarised above was used to answer RQ2 according to context. However, to place the answer in a general context, the following statement addresses the purpose of the dissertation:

The characteristics of the business ecosystem in a transport system under technological change can be explored through identifying the key stakeholders with their roles and functions, examining their relationships within the ecosystem, and illustrating the relationships in a business ecosystem model. Different characteristics appeared in the EV ecosystem and the Finnish road weather and maintenance ecosystem because of their different contexts. However, some commonalities were observed, such as the potential role of system integrators (EVAI in EV ecosystem, and the next generation DSS provider in the latter ecosystem). The joint development between several key stakeholders was deemed a promising value-capture strategy within the ecosystem, which was relevant for both ecosystems in particular and the other business ecosystems on transport system under technological change in general.

RQ3: What are the characteristics of business model in the emerging transport systems as the result of technological change? How can different business model topologies and options be examined and evaluated? What kind of strategy could be approached for designing a viable business model in the emerging transport system?

Article V and partially Articles I and IV were used to answer RQ3. RQ3 was formulated to view the business model element in understanding the emerging transport system. In Article V, the existing business models of ITS services, mainly the advanced travellers information systems (ATIS), were examined. Based on these existing business models, the generalised traditional business model framework was constructed. The dynamic environment, including market, regulation and technological change, caused the business model to evolve. The evolving (modern) business model framework was then conceptually proposed to help the business planners and policy makers understand its characteristics. The model utilised the morphological analysis approach. To enrich the knowledge of business models, Article I and IV partially highlighted several examples of business models in another case study, that is, the electro-mobility system. The findings are summarised as follows:

1. *The existing business models of ATIS are identified, including the public-centred model, contract-based mutual system model, franchise-based operation model, private sector competition model, value-added resellers model and business-to-business model.*
2. *The modern business model of ITS services has several characteristics. For example, rather than relying on a software installed on a device, current processing data can be outsourced to a cloud computing service, which consequently changes the revenue structures of these services. In addition, a current solution includes the interoperability between service providers or across borders, increasing user-friendliness and requiring less effort by the customer in using the same services.*
3. *A modern ITS services business model topologies framework was proposed. The model is presented in Article V (p. 7, Figure 3).*
4. *There is still uncertainty concerning earning logics (business models) within electro-mobility systems. Several options and models were proposed: the energy package model, maintenance package model, part-subsidy model and full-subsidy model. Other possible leasing models are flexible mileage models: the unlimited miles model, maximum number of miles model and pay-as-you-go model (Article I). In Article IV, several studies on EV business models were reviewed, including the following: 1) a morphological analysis of a business model for electric cars considering three components: the battery, infrastructure, and system services (Kley et al., 2011); 2) regulatory framework and business models for charging PHEVs*

(San Roman et al., 2011); and 3) overview of electric recharge grid operator (ERGO) business models (Andersen et al., 2009).

Based on the findings that were used to answer RQ3, a broad and common answer in two case studies (ITS and EV) is presented as follows:

Transport system business models are evolving because of the dynamic environment, including technological change. Modern business models seem to be more open, flexible, interoperable, and they facilitate both one and more functions (layers) within the value chain or ecosystem. To understand the business topologies within the value network or ecosystem, a morphological analysis can be conducted. However, despite the myriad of models proposed either as a concept or a practice, the winning business model formula and strategy remained unclear, especially in the EV ecosystem, which could be investigated in future research.

3.3 Research synthesis

The research findings were presented and summarised in the previous section. This section presents the synthesis of the research findings. The research synthesis can be defined as the process of deeply examining the research phenomena in order to extend understanding or to obtain new ideas and insights based on the identified research results or the entire research process. Figure 5 illustrates how the research process contributed to the research findings and led to the research synthesis, based on which recommendations for future research are offered.

In this dissertation, the synthesis of the research was mainly driven by an additional question that was formulated during the research process:

How do we understand the transport system under technological change or even any other technological system by integrating the market, business ecosystem and business model viewpoints?

To answer that question, the author attempted to develop a framework that could help researchers, business owners and policy makers to understand the transport system under technological change from the perspectives of the market, business ecosystem and business model. The relation among the three perspectives were previously examined and illustrated in Figure 11 in Section 2.4 as an a-priori model of a theoretical framework. This model was further used as the basis to develop the framework model. Moreover, the business model topology framework described in Article V inspired the author to use the same tool and method to construct the framework. The constructed framework model was then applied to the empirical case studies conducted in this dissertation to know how it performs.

Figures 15 to 17 show the research synthesis of the findings of each case study in the dissertation, which is represented as a *house* in the morphological framework model of understanding the transport system phenomena under technological change in three different systems: 1) the transport information-intensive services (ITS) system; 2) the electro-mobility system; and 3) the road weather and maintenance system. Finally, based on the three different areas of application, a generic framework is constructed (Figures 18 and 19), which is the main contribution of this dissertation.

3.3.1 Transport information-intensive system

Transport information-intensive system services are an emerging sector in ITS, which, as discussed in Chapter 1, are consequently a part of transport systems under technological change. This case study was described in Article V, which focused on the business model. In Article V, a modern business model topology framework was constructed using the morphological box approach, which was used to explain how to understand the transport system under technological change from the perspectives of the market, business ecosystems, and business models. That model focused on describing the business model topologies in information-intensive ITS applications, whereas inspired by the former work, in this dissertation the new *house* of morphological framework model is constructed (Figure 15).

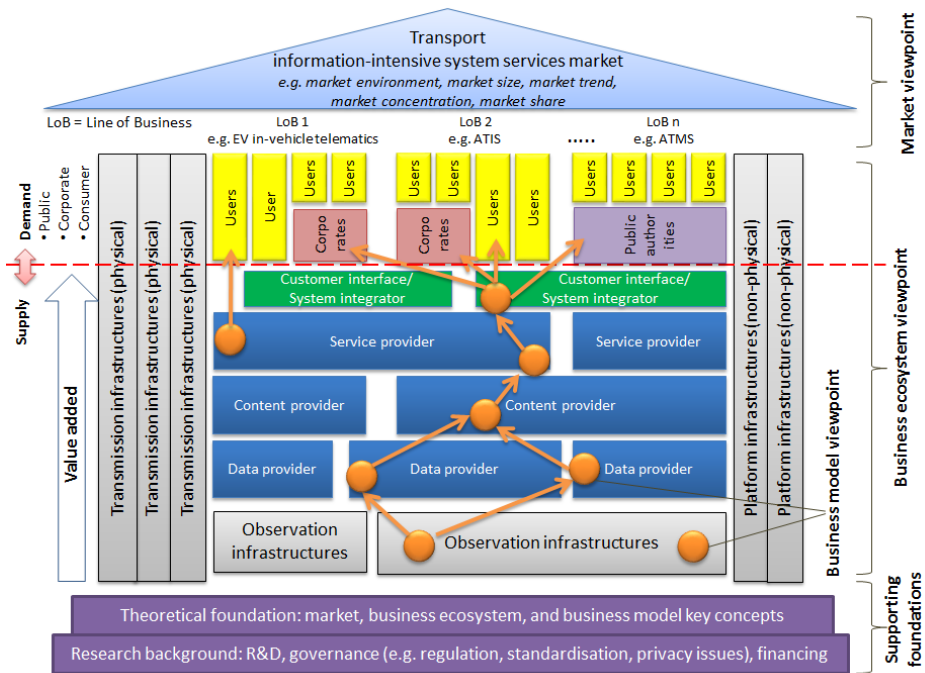

Figure 15. House of morphological framework for understanding transport information-intensive systems

Employing the morphological analysis approach, the framework is a **house** that is built on four key elements. The first element is the roof of the house, namely the transport information-intensive system services market viewpoint. A good understanding or a proper knowledge of the market is crucial because it will protect the business planners or policy makers from failing to take the right decisions to survive the competition or to better serve the society. The market viewpoint consists of several measures or indicators, such as the market environment, market size, market trend, market concentration, market share and so forth, which collectively form the characteristics of the observed market to be further taken into account.

The second element consists of the **pillars of the business ecosystem**. The business ecosystem viewpoint is the main pillar on which to build the understanding of the research phenomenon, which in this dissertation is the transport system under technological change. The pillars of the business ecosystem consist of multiple actors in the value chain or network, which possibly serve multiple downstream actors, multiple transmission infrastructures and platforms (i.e., the vertical grey pillars alongside the value-chain actors) and provide multiple lines of businesses (LoB) or services to multiple end-customers. The members of the value chain vary according to the types of services they provide.

Figure 15 shows three examples of services and applications in transport information-intensive systems: EV in-vehicle digital information services (telematics); advanced travellers information systems (ATIS); and advanced traffic management systems (ATMS), all of which typically involve the same actors as in the value chain, including observation infrastructures, data providers, content providers, service providers, customer interface/system integrators and the end users. The framework facilitates multiple choices of vertical integration and competition in both horizontal and vertical directions. Possible intermediary actors between the end users and customer interface are included in the model, such as the role of the road authorities in ATMS and corporate customers (B2B) in ATIS and EV in-vehicle telematics. These three different types of customers (i.e. end users, corporate and public authorities) are on the demand side, whereas the upstream actors are on the supply side.

The third element, which is also the third viewpoint explored in this dissertation, is the business model. This element belongs to each company that does particular business within the ecosystem. It is illustrated as the circular nodes (orange colour) that cover either a single or multiple layers of value chain roles. The arrows connecting the nodes show the services and business offerings to the following downstream actor (i.e., their direct customers), and the money/cash flows come from the opposite direction. Because every business model is designed for a single company, different choices of strategies or characteristics are utilised. Thus, a deep analysis of each particular business model is required. However, the topologies of these business models can be examined through this framework by observing the collective and collaborative relationships among the stakeholders and their compatibility within the ecosystem.

Finally, the fourth layer, which is the foundation of the house of this morphological framework, comprises the supporting elements or activities as enablers, supplements, pre-requisites or the knowledge needed to understand the phenomena. This layer consists of the research and development activities by research institutions, the organisation, governance and financing by regulators or industry associations. Understanding these external factors in addition to the elements described above could lead the researcher to understand the phenomena. In addition, this layer could also be filled by with several theoretical foundations that support and facilitate the analysis in contemplating the research phenomena and findings.

3.3.2 Electro-mobility system

The same framework could be applied to another area of emerging transport systems under technological change, namely the electro-mobility system. It includes various kinds of elements, such as EVs, charging infrastructures, EV drivers, battery technology providers and so forth. Different types of viable business models that are proposed and tested in the market are included in discussing the electro-mobility system.

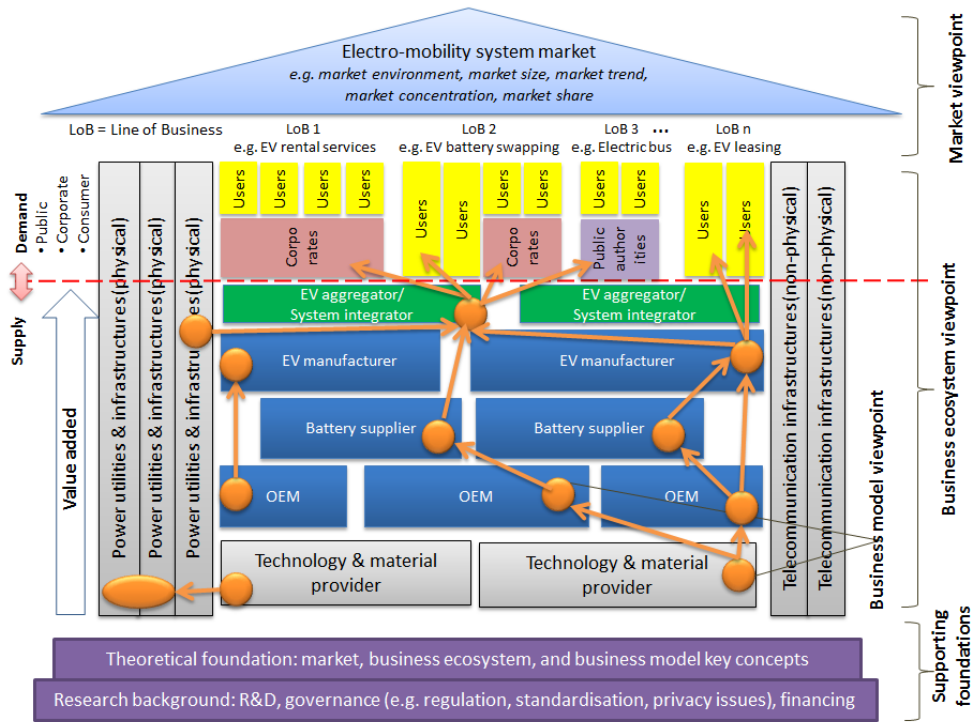

Figure 16. House of morphological framework for understanding electro-mobility systems

In addition to reflecting on the house of morphological framework (Figure 16), first we need to gather information about the market for electro-mobility systems, which includes EV market aspirations, market growth and market size as the first elements required to understand the phenomena. Second, we need to examine the electro-mobility system as a business ecosystem that comprises both a demand side (i.e. public, corporate and consumer) and a supply side (i.e. OEM, battery supplier, EV manufacturer and EV aggregator/integrator). On the demand side, four different lines of business are presented as examples: EV rental services, EV battery swapping stations, electric buses and EV leasing services.

Multiple actors in the supply chain can work in multiple power utilities and telecommunication infrastructures to provide products or services to their customers, and they could also be enabled by different providers of technology and material. The third element consists of the possible business model topologies, including their offerings and revenue logic, which facilitate vertical or horizontal integration and competition among them. Finally, the fourth element comprises the information about the research background and theory as foundation of the house. All four key elements will lead the way to understanding electro-mobility system phenomena.

3.3.3 Road weather and maintenance system

In this dissertation, the third area of the transport system under technological change studied is the road weather and maintenance system. It includes a wide range of applications and services, such as weather information services, traffic control systems (including variable message sign), and winter road maintenance. Figure 17 shows how the same framework could be applied to understand the road weather and maintenance system.

In general, the roof and foundation of the framework is similar to the former two examples (i.e., the transport information-intensive system and the electro-mobility system), which are primarily activities to gather information about the market and supporting knowledge (i.e. background and theoretical foundation), respectively. The only differences are their contexts. In this case, market information about the road weather and maintenance system is gathered and analysed, as well as other topics related to the background of the phenomena and their supplementary theories.

The latter two elements, the business ecosystem and the business model, could vary because they might have different supply chain actors, customers, offerings and revenue logics. In the road weather and maintenance system, the supply chain actors comprise the system components provider, road weather and condition forecast provider, service provider and customer interface/ system integrator. Each component works in multiple transmission and platform infrastructures, and it is enabled by different technology and observation infrastructure. Different topologies of business models can also be illustrated in the framework to show their possible offerings and revenue logic.

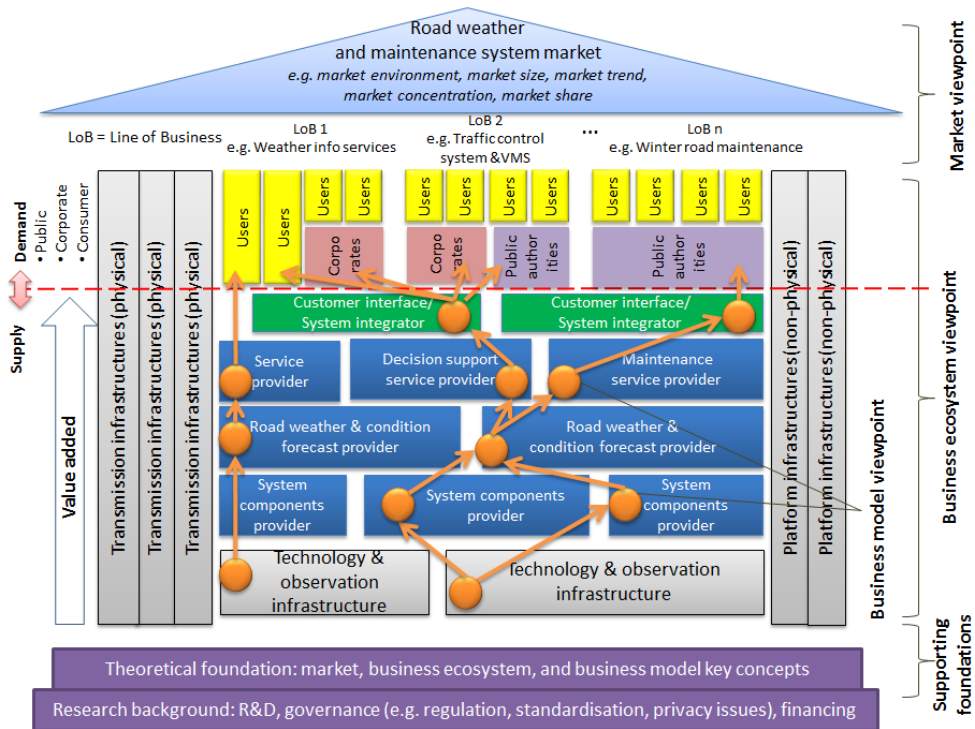

Figure 17. House of morphological framework for understanding road weather and maintenance system

3.3.4 Scaling up towards a generic framework

Understanding the transport system under technological change can be approached by using the proposed framework. As mentioned earlier, the framework was primarily inspired by the work in Article V. It combines merging business models, business ecosystems, value network constellations and market/industries into one descriptive model, called as the house of morphological framework model. The model resembles the structure of a house, utilising morphological boxes as a tool for morphological analysis. Morphological analysis (or general morphological analysis) is a method developed by Fritz Zwicky (for some 30 years: between the 1940s until his death in 1974) for structuring and investigating the total set of relationships contained in multidimensional, non-quantified complex problem (Ritchey, 1998).

In this dissertation, three cases were analysed using different notations and different resolutions (business ecosystem or industry), including a transport information-intensive services system, an electro-mobility system, and a road weather and maintenance system. These could serve as application cases of the proposed

framework model. These three cases are translated, synthesised and generalised using the house of morphological framework model.

Based on the three application cases, a generic framework can be constructed, which includes generic definitions of the elements of the model. Figure 18 utilises the framework to view the transport system under technological change in a generic light.

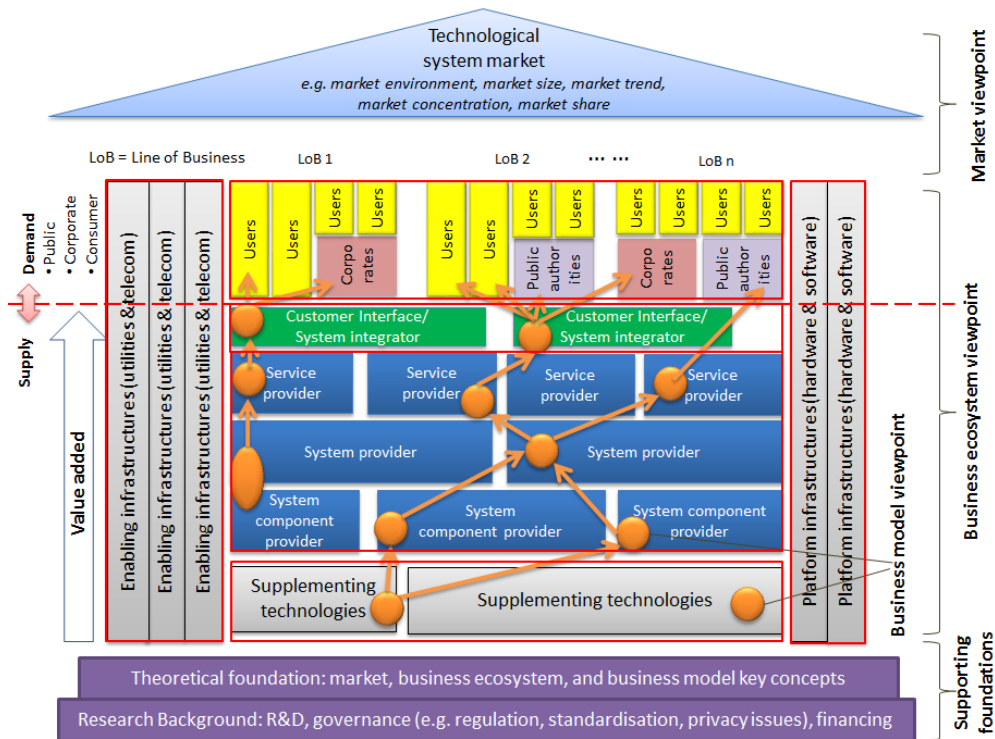

Figure 18. Generic house of morphological framework for understanding transport systems under technological change

The house consists of the following four key elements:

1. The technological system market as the roof.

This is the roof of the framework. It works as *the umbrella* to protect the main beneficiaries of the model (policy makers or business planners) from misunderstanding the market. It also represents *the vision* that drives and frames them in the right context, which contains a set of activities used to gather adequate information about the market. This element consists of several components that are known as market configuration or market measures (e.g. Xu, 2005): market environment, market size, market trend,

market concentration and market share. The technological system includes the transport system or any other systems that arises as a result of the technological change.

2. The pillars of *business ecosystem*

The pillars form the main body of the house. They represent both the demand and the supply side, which primarily consists of customers, value chain actors (blue-coloured boxes), and enablers or supporting pillars (grey-coloured boxes) (Figure 18). There are different types of costumers, such as public authorities, corporate customers and end users or consumers. These three customers form the demand for the supply chain actors. The supply chain actors could vary depending on the context used as the object studied. In this generic transport system model, typical supply chain actors are the *system component provider* (provides components for equipment or a particular system), the *system provider* (provides a particular system mainly to the service provider) and *service provider* (provides transport-related services).

The customer interface or system integrator (green-coloured boxes in Figure 18) is the actor who takes an intermediary role, bridging the service provider and the customers, which does not necessarily add new value. This actor could be a company or a platform that is developed, operated and maintained by a consortium (e.g. MOBiNET).

Finally, the supporting enablers are the infrastructures or technologies that enable the supply chain actors, integrators and customers. These include enabling infrastructures (utilities and telecommunication), platform infrastructures (hardware and software) and supplementing technologies (e.g. battery technology and ICT).

3. The elements of *business model constellation and configuration*

These elements consist of business model perspective that contain a value network constellation and configuration in the business ecosystem. In Figure 18, these elements are illustrated by orange-coloured circles and arrows. A firm can have either a single business model for a single product or service or multiple business models, which facilitates both vertical and horizontal integration and competition. The direction of the arrows indicates the value generation or product and service offerings to the downstream actors or customers, whereas the opposite indicates the revenue stream.

4. The ground foundation of the house

As the foundation of the house, a thorough understanding of the supporting theories and the research background is required to conduct the analysis and facilitate the synthesis of the results. In this research, the theoretical

foundation consists of the theories of market research and analysis, business ecosystems, and key concepts of business models. The supporting research background includes research and development activities around the topic, the governance issue, and financing.

Figure 19 presents a simplified generic model of the house of the morphological framework to explore the transport system under technological change: 1) demand layer; 2) customer interface and system integrator; 3) key supply chain actors; 4) supplementing technologies; 5) enabling infrastructures (utilities and telecommunication); 6) platform infrastructures (hardware and software); 7) business model viewpoint; 8) business ecosystem viewpoint; 9) market viewpoint; and 10) supporting foundations. The latter four were previously defined and were determined as the four key elements of the house model.

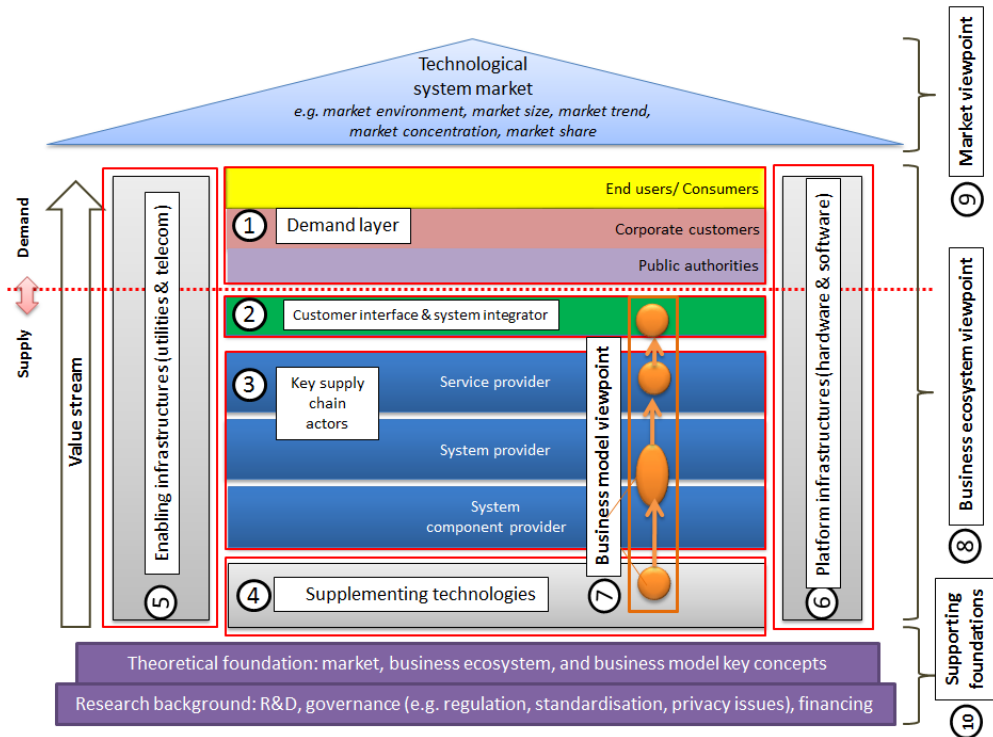

Figure 19. Simplified generic house of morphological framework for understanding systems under technological change

4. Discussion and evaluation

The results are discussed and evaluated in this chapter. First, the implications of the research are discussed by considering the results in relation to several related issues, which were observed during the research. Second, the research is evaluated in terms of its reliability and validity. In this sub-section, the entire research process is carefully evaluated by presenting several strengths and weaknesses of the research approach adopted in this dissertation. Third, some future research needs are addressed, mainly with regard to the limitations of the present study.

4.1 Implications

The dissertation attempted to contribute mainly to the business aspect of analysis, by exploring a transport system under technological change. Although they are not the main concern, the technological and social aspects were not entirely excluded from the research because understanding them is needed in order to have a better view of the phenomena. From a theoretical point of view, the dissertation mainly contributes to market research and analysis, business ecosystems, business models and the integration of theories, particularly the transport sector under technological change. This was achieved by conducting an exploratory research using several case studies and viewing the phenomena from three perspectives.

First, the dissertation contributes to theories of market research and analysis by conducting market research and analysis using several approaches. In the Finnish ITS market, a quantitative and primary market research analysis was used. The market measures, which included market size, market trend and market concentration were calculated by utilising ITS supply side data (turnover figures) of the ITS industry in Finland, which were gathered from publicly available sources. The market research process or methodology, including technique and data sources, could be replicated in market research in different industries in different geographical areas.

In this dissertation, a different approach was used to discuss or analyse the EV market. In this case, because of the broad scope (global and multinational), secondary market research was conducted. This approach is probably the most practical and easiest to use when the goal is to understand the market. This approach relies on reviewing or studying published market reports and surveys. From these sources, several kinds of information (e.g., market size, share, or trend) that are needed to understand the market could be gathered. However, unlike the former, the information gathered in secondary market research is sometimes partially inaccessible. Thus, the researcher needs to purchase entire reports, which are usually quite expensive. Furthermore, the data provided in the market reports are sometimes unexplained or questionable, especially when the reader is interested to know about the research process or the source of data. Therefore, to tackle this limitation, careful steps need to be taken into account. This dissertation revealed that in order

to conduct a market research and analysis, both approaches (primary and secondary research) could be applied, depending on the geographical scope, the availability of data, the resources (e.g. time and money), and the research objective. Furthermore, this research also confirmed that a framework for understanding customer-focused research based on knowledge richness and managerial purposes (Mittal, 2015) could be applied.

Furthermore, the identified characteristics of the market in a transport system under technological change, which are still assumed to be immature, have several implications for both business planners and policy makers. Business planners could hesitate to enter the market except those who had the required technology or capital. Therefore, in the beginning phase, particular efforts to increase customer and end user awareness and acceptance are needed in addition to the support of governments and other key stakeholders in the provision of initiatives, incentives and demonstration activities.

Second, the dissertation also contributes to the theory of business ecosystems. An ecosystem model was constructed for electro-mobility systems and road weather and maintenance systems. These case studies revealed that the business ecosystem model could be useful in examining the relationship between key stakeholders and analysing their roles in and the dynamics of the ecosystem. The identified key stakeholders, challenges, roles, and their interactions within the ecosystem were the main results that could enrich the current business ecosystem literature.

Third, the dissertation's main contribution to business model theory is its discussion of business model evolution and topology. The dissertation also proposed a morphological framework to describe the value-generation logic in the modern business model. This framework was then used to develop the house model, which is the main contribution of the dissertation.

In addition, another implication arises from the house model, which integrates three different perspectives (market, business ecosystem and business model) to understand the transport system, which was discussed in Section 3.3. This innovative model has several implications. For example, the addition of new actors with new technologies could change the value network configuration on the supply side. Moreover, changes in the demand specifications of the public sector (and perhaps from the end users) could require new constellations with more actors than traditionally observed (e.g. the FIRWE case). Value generation or co-creation logic could also change.

From a strategic perspective, the model suggests that all the elements of the model are subject to change: demand, platforms, infrastructures, actors and their roles, and technologies. Therefore, the model could facilitate a flexible and systematic 'helicopter view' that was adaptable to change, so that either the policy makers or business planners could examine the phenomena and take the right decisions accordingly. Hence, the main beneficiaries of the proposed model are members of strategic management at the policy-making and corporate levels. In summary, the house model accommodates new actors: it is furnished with new technologies; some old ones may be thrown out; the walls, ceiling and floor change in structure and shape.

The same approach, logic and framework used to understand the phenomena could be utilised to examine other emerging systems under technological change, such as the healthcare services system, education system, or building and construction system.

Interrelation between theoretical concepts

Several theoretical concepts were employed in this dissertation to answer the research questions as well as to synthesise the results and construct the house model. The concepts are interrelated, and they potentially overlap. Hence, to avoid bias or ambiguity, the following explains the logical links among the concepts and their relationships:

- *Business models need value chains.* Business models define the structure of the *value chain* within the firm, which is required to create and distribute the offering and determine the complementary assets needed to support the firm's position in the chain (Chesbrough and Rosenbloom, 2002).
- *Value chains are part of value networks.* This implies that value networks comprise several value chains that provide value to users according to their demand.
- *Value networks need business ecosystems.* Business ecosystems can host and facilitate value networks and therefore enable value chains to combine business models to provide value to end users.
- *Ecosystems need markets.* The ecosystem models described in Article IV and Article III (i.e., the EV system and the road maintenance ecosystem) include the market (end users/customers) as a key actor within the ecosystem, which must be taken into account in order to gain advantages from the ecosystem. This implies that ecosystems are a fuzzy compilation of value networks, but they include the competition between the ecosystem actors and the market actors having the demand (competition + cooperation = coopetition).
- *Industries may include some ecosystems, and ecosystems can cross industry boundaries.* Ecosystems are a subset of industries, but they include the demand side, whereas industry does not. *Industry+* is derived from national accounting systems because the private sector needs to be structured. Ecosystems do not necessarily follow industry division lines, and they can exist between industries or within industries.

4.2 Reliability and validity of the research approach

The theoretical background in the dissertation as well as its constituent articles serve to ensure the validity of the research. The articles included in the dissertation were carefully evaluated and passed through a blinded peer review process, which

found them to be reliable and valid. Because this dissertation is based on these articles, it follows that its validity and reliability is also confirmed.

The dissertation was exploratory in purpose and wide in context. It used empirical case studies and employs both qualitative and quantitative approaches in the research process. Different approaches require different ways of validating the research. Therefore, there is no single way of validating this research. However, although the quantitative approach is used (i.e. in the Finnish ITS market case study), this dissertation is generally qualitative because it seeks to understand a particular phenomenon rather than generalise it. The case study strategy was selected because it allows for studying a phenomenon in its context, and it provides a broad view of the phenomenon, which is in line with the exploratory purpose of the dissertation.

Qualitative research is evaluated for reliability and validity. Reliability concerns the consistency of the research in corresponding to the real world across different studies or projects. The reliability of this research was ensured by using the same interview set up and procedure in every interview, standardising the data collection methods (survey and semi-structured interviews). Both the primary data and secondary data were carefully checked before they were analysed, and several cross-checks were performed to eliminate potential biases. The data cross-checking was done by using multiple sources of data and confirmation with the interviewees and other researchers.

Because the case studies used in this dissertation are unique, the repeatability of the research could be challenging. It would be unlikely that a similar research could obtain exactly the same results. For example, because some case studies are country and time specific, different results would likely be found in the contexts of different places and times. For example, the ITS market figures in countries such as Germany or the US have different structures and compositions because they have large markets and strong automotive industries. Furthermore, because situations and practices evolve and change, thus different findings or answers will result. Another possible reason is the role of the researcher. The analysis and the synthesis of the findings are highly dependent on the interpretation of the researcher even though the steps of the data analysis can be repeated.

Validity concerns the degree to which the findings and results are interpreted correctly. Several viewpoints can be taken into account in the validation of the research process, such as methodological choices, the data sources and the generalisability.

Because of the broad scope of this dissertation, multiple methods were employed. As discussed in Chapter 1, the methodological choices were highly dependent on the purpose of the research and the availability of the data. For example, to understand the ITS market in Finland, a primary descriptive research that relies on the national data set of Finnish ITS industry was selected because the scope was reasonable (not too large), and there were no research results available at the time which could have been used to answer questions about the market. However, when the scope is wide and borderless, such as the global EV market, secondary research is the most efficient and effective approach. The dissertation also relied on

existing literature reviews to explore the studied phenomena. To enhance the validity of the methodological choices, the research approaches were discussed, and the data analysis was conducted with the supervisor and other researchers.

The data used in the dissertation were also carefully collected in order to enhance the validity of the research. In this dissertation, the validity was enhanced by using multiple sources of evidence in the data collection and using data triangulation. Moreover, the data, analysis and drafts of the dissertation were reviewed and commented on by the interviewees and other researchers.

Another aspect of validity is the ability to apply the research results in other contexts, which is termed the generalisation of the results (i.e. external validity). However, in qualitative research, generalisation of the results is challenging and limited. Therefore, this dissertation discussed and explored the studied phenomenon rather than focusing on producing results that could be generalised. However, the external validity of the research was enhanced by defining the research scope and boundaries carefully and comparing the findings and results to those in the existing literature. In the dissertation, several cases were country-specific (ITS market and winter road maintenance case study), so the results would be difficult to generalise to other contexts. However, in other cases (i.e. the EV market and the ecosystem), the findings could be generalised to other contexts.

All research has limitations and the potential for improvement, but there is no reason that the current research is not sufficiently valid and reliable in meeting its stated purposes.

4.3 Recommendations for future research

No research is without limitations. This research has attempted to provide initial insights into the studied phenomena in the emerging transport sector regarding technological change, especially from the perspective of business. Although the research makes theoretical and practical contributions, there are several possibilities for further research. One of the clear research needs identified is empirical research on particular businesses in terms of their market, their position within the business ecosystem, including strategies for gaining advantage and a viable business model. A firm-specific analysis could provide detailed knowledge that would enrich the existing findings.

Another recommendation for future research is to expand the research scope by utilising different sectors of applications in the transport system under technological change, such as the bio-fuel transport system or fuel cell EVs, which are not covered in this study. Another option could be to apply different modes of transport, such as rail, maritime and aviation transport systems.

The synthesised meta-model that integrates the market, business ecosystem and business model is the main contribution of this dissertation. It would be interesting to see how the house model could be used and developed in applications to other industrial sectors.

Several other methods could be applied to explore the transport system under technological change in future research, such as foresight analysis, system dynamics or financial analysis. Moreover, the use of different perspectives could enrich the understanding of the transport sector under technological change.

References

- Aapaoja, A., Leviäkangas, P. and Möttönen, V., 2014. *Innovation architecture of renewable energy solutions pilots in Oulu . Innocity project case study*. VTT Technology 195. Espoo: VTT.
- Afuah, A. and Tucci, C. L., 2001. *Internet business models*. New York: McGraw-Hill/Irwin.
- Afuah, A. and Tucci, C. L., 2003. *Internet Business Models and Strategies*. 2nd ed. Boston: McGraw Hill.
- Afuah, A., 2004. *Business models: A strategic management approach*. New York: Irwin/McGraw-Hill.
- Alt, R. and Zimmerman, H. D., 2001. Introduction to special section on business models. *Electronic Markets*, 11(1), pp. 3. 9.
- Amit, R. and Zott, C., 2001. Value creation in e-business. *Strategic Management Journal*, 22(2), pp. 493. 520.
- Andersen, P. H., Mathews, J. A. and Rask, M., 2009. Integrating Private Transport into Renewable Energy Policy: The Strategy of Creating Intelligent Re-charging Grids for Electric Vehicles. *Energy Policy*, 37(7), pp. 2481. 2486.
- Applegate, L. M., 2000. E-business models: Making sense of the internet business landscape. In: G. Dickson & G. DeSanctis, eds. *Information technology and the future enterprise: New models for managers*. Englewood Cliffs, NJ: Prentice-Hall, pp. 49. 101.
- Applegate, L. M., 2001. Emerging e-business models. *Harvard Business Review*, 79(1), pp. 79. 87.
- Barney, J. B., 1999. How firm capabilities affect boundary decisions. *Sloan Management Review*, 40(1), pp. 19. 32.
- Barney, J., Wright, M. and Ketchen, D., 2001. The resource-based view of the firm: ten years after 1991. *Journal of Management*, 27(6), pp. 625. 641.
- Battistella, C., Colucci, K., and Nonino, F., 2012. Methodology of Business Ecosystems Network Analysis: A Field Study in Telecom Italia Future Centre. In: M. De Marco et al., eds. *Information systems: crossroads for organization, management, accounting and engineering*. Physica-Verlag, pp. 239. 249.

- Berg, B., L. and Lune, H., 2012. *Qualitative research methods for the social sciences*. USA: Pearson Education.
- Berkers, F., Koers, W., Colucci, K., Kadlec, O., Puiu, D., Roelands, M. and Menoret, S., 2013. D1.3 Vision of the future business ecosystem, new roles and models of acceptance. iCore report, Oct. 2013.
- Betz, F., 2002. Strategic business models. *Engineering Management Journal*, 14(1), pp. 21. 27.
- Bonaccorsi, A., Giannangeli, S., and Rossi, C., 2006. Entry strategies under competing standards: Hybrid business models in the open source software industry. *Management Science*, 52, pp. 1085. 1098.
- Boselly, E., 2001. *Benefit/Cost Study of RWIS and Anti-Icing Technologies*. Final report. Washington: Transportation Research Board, National Research Council.
- Brousseau, E. and Penard, T., 2006. The economics of digital business models: A framework for analyzing the economics of platforms. *Review of Network Economics*, 6(2), pp. 81. 110.
- Brown, L. O., 2008. *Market Research and Analysis*. Wildside Press LLC.
- Bryman, A. and Bell, E., 2007. *Business research methods*. New York: Oxford University Press.
- Burgess, L., Toppen, A., and Pretorius, P., 2007. *Real-time Traveler Information Services Business Models: State of the Practice Review*, FHWA-HOP-07-115, May 2007, Federal Highway Administration.
- Camarinha-Matos, L. M., Afsarmanesh, H., Galeano, N. and Molina, A., 2009. Collaborative Networked Organizations . Concepts and Practice in Manufacturing Enterprises. *Computers & Industrial Engineering*, 57(1), pp. 46. 60.
- Casadesus-Masanell, R. and Ricart, J. E., 2010. From strategy to business models and to tactics. *Long Range Planning*, 43, pp. 195. 215.
- Chesbrough, H. W. and Rosenbloom, R. S., 2002. The role of the business model in capturing value from innovation: Evidence from Xerox Corporation's technology spinoff companies. *Industrial and Corporate Change*, 11, pp. 533. 534.

- Choi, K., Lee, C. and Son, Y., 2001. Traffic information and Some Business Models. *KSCE Journal of Civil Engineering*, 5(2), pp. 113. 122.
- Curran, S. J., Wagner, R. M., Graves, R. L., Keller, M. and Green Jr., J. B., 2014. Well-to-wheel analysis of direct and indirect use of natural gas in passenger vehicles. *Energy*, 75, pp. 194. 203.
- Di Valentin, C., Weiblen, T., Pussep, A., Werth, D. and Loos, P., 2012. Quantifying the Quality of Business Models: A State of the Practice. In: *CENTRIC 2012: IARIA International Academy, Research, and Industry Association*.
- Donath, R., 1999. Taming e-business models. *ISBM business marketing web consortium*, 3(1). State College (PA): Institute for the Study of Business Markets, pp. 1. 24.
- Dubosson-Torbay, M., Osterwalder, A. and Pigneur, Y., 2002. E-business model design, classification, and measurements. *Thunderbird International Business Review*, 44(1), pp. 5. 23.
- Dutta, S., Geiger, T. and Lanvin, B., eds., 2015. *The Global Information Technology Report 2015*. Geneva: World Economic Forum.
- Dyer, J. and Singh, H., 1998. The relational view: cooperative strategy and sources of interorganizational competitive advantage. *Academy of Management Review*, 23(4), pp. 660. 679.
- European Commission, 2009a. *Directive 2009/33/EC of the European Parliament and of the Council of 23 April 2009 on the Promotion of Clean and Energy-efficient Road Transport Vehicles*. Available at: <http://eur-lex.europa.eu/legal-content/EN/ALL/?uri=CELEX:32009L0033>.
- European Commission, 2009b. *R&D involvement in the EU Economic Recovery Plan: focus on the three Public Private Partnerships* [Online] Available at: http://ec.europa.eu/transport/themes/urban/vehicles/road/doc/2009_03_26_eu_economic_recovery_plan.pdf [Accessed: 13/11/2015].
- European Commission, 2010. *Directive 2010/40/EU of the European Parliament and of the Council of 7 July 2010 on the Framework for the Deployment of Intelligent Transport Systems in the Field of Road Transport and for Interfaces with other Modes of Transport*. Available at: <http://eurlex.europa.eu/LexUriServ/LexUriSrv.do?uri=OJ:L:2010:207:0001:0013:EN:PDF>.

- European Commission, 2012. *Clean transport, urban transport: Electric vehicles* [Online] Available at: http://ec.europa.eu/transport/themes/urban/vehicles/road/electric_en.htm [accessed: 13/11/2015].
- European Telecommunications Standards Institute, 2012. *Intelligent Transport Systems*. [Online] Available at: <http://www.etsi.org/index.php/technologiesclusters/technologies/intelligenttransport> [Accessed: 12/11/2015].
- Ezell, S., 2010. *Explaining International IT Application Leadership: Intelligent Transportation Systems*. ITIF, January 2010.
- Ferreira, F., 2010. *ITS Action Plan and Directive - Framework for the Deployment of Intelligent Transport Systems*. P3ITS Workshop, ERTICO, September 2010.
- Figueiredo, L., Jesus, I., Machado, J. A. T., Ferreira, J. R. and de Carvalho, J. L. M., 2001. Towards the development of intelligent transportation systems, *Intelligent Transportation Systems, 2001. Proceedings*. 2001 *IEEE*, pp. 1206. 1211.
- Finnish Meteorological Institute, *Climate in Finland*, [Online] Available at: <http://en.ilmatieteenlaitos.fi/climate> [Accessed: 18/11/2015].
- Finnish Ministry of Transport and Communications, 2009. *Finland's Strategy for Intelligent Transport*.
- Frost & Sullivan, 2010. *360 Degree Perspective of the Global Electric Vehicle Market Opportunities and New Business Models . 2010 Edition*.
- Fruchterman, T. M. and Reingold, E. M., 1991. Graph drawing by force-directed placement. *Software: Practice and Experience*, 21(11), pp. 1129. 1164.
- Garrison, W. L., 2000. *Technological Changes and Transportation Development*. Research paper. UCTC No. 495. The University of California Transportation Center, University of California at Berkeley. [pdf] Available at: <http://www.uctc.net/research/papers/495.pdf>.
- George, G. and Bock, A., 2009. *The business model in practice and its implications for entrepreneurship research*. Working paper, Imperial College, London.
- Giannoutakis, K. N. and Li, F., 2011. Developing Sustainable e-Business Models for Intelligent Transportation Systems (ITS). In: Skersys, T., Butleris, R., Nemuraite, L. and Suomi, R., eds. 2011. *Building the e-World Ecosystem*. Berlin and Heidelberg: Springer-Verlag, pp. 200. 211.

- Giannoutakis, K. N. and Li, F., 2012. Making a Business Case for Intelligent Transport Systems: A Holistic Business Model Framework. *Transport Reviews*, 32(6), pp. 781. 804.
- Gordijn, J. and Akkermans, H., 2001. Designing and evaluating e-business models. *IEEE Intelligent System*, 16(4), pp. 11. 17.
- Gordijn, J. and Akkermans, J., 2003. Value-based requirements engineering: exploring innovative e-commerce ideas. *Requirements Engineering Journal*, 8, pp. 114. 135.
- Gordijn, J., Akkermans J. M. and Van Vliet, J. C., 2000. Business Modeling is not Process Modeling. In: S.W. Liddle, H.C. Mayr, and B. Thalheim, eds. 2000. *Conceptual Modeling for E-Business and the Web*, Berlin and Heidelberg: Springer-Verlag, pp. 40. 51.
- Gossain, S. and Kandiah, G., 1998. Reinventing value: The new business ecosystem. *Strategy & Leadership*, 26(5), pp. 28. 33.
- Guarnieri, M., 2012. Looking back to electric cars. In *HISTory of ELECTRO-technology CONFERENCE (HISTELCON), 2012 Third IEEE*. Pavia, 5-7 September 2012, pp. 1. 6.
- Hamel, G., 2000. *Leading the revolution*. Boston: Harvard Business School Press.
- Hanke, C., Hulsmann, M. and Fornahl, D., 2013. Socio-Economic Aspects of Electric Vehicles: A Literature Review. In: M. Hulsmann and D. Fornahl, eds. 2014. *Evolutionary Paths towards the Mobility Patterns of the Future*. Berlin and Heidelberg: Springer-Verlag, pp. 13. 36.
- Hautala, R. and Leviäkangas, P., 2007. Ilmatieteen laitoksen palveluiden vaikuttavuus: hyötyjen arviointi ja arvottaminen eri hyödyntäjätoimialoilla [in Finnish]. VTT Publications 665. Espoo: VTT. Available at <http://www.vtt.fi/inf/pdf/publications/2007/P665.pdf>.
- Hearn, G. and Pace, C., 2006. Value Creating Ecologies: Understanding Next Generation Business Systems. *Foresight*, 8(1), pp. 55. 65.
- Heistracher, T., Kurz, T., Masuch, C., Ferronato, P., Vidal, M., Corallo, A., Briscoe, G. and Dini, P., 2004. Pervasive Service Architecture for a Digital Business Ecosystem. In: *WCAT04 Workshop (ECOOP 2004 Conference) 2004*: Oslo, Norway. pp. 1. 10.

- Hill, N., Brannigan, C., Smokers, R., Schrotten, A., van Essen, H. and Skinner, I., 2012. EU Transport GHG: Routes to 2050 II. Final report, 29 July 2012. Available at: <http://www.eutransportghg2050.eu/cms/assets/Uploads/Reports/EU-Transport-GHG-2050-II-Final-Report-29Jul12.pdf>.
- Horowitz, A. S., 1996. The real value of VARS: resellers lead a movement to a new service and support. *Marketing Computing*, 16(4), pp. 31. 36.
- Iansiti, M. and Levien, R., 2004. Strategy as Ecology. *Harvard Business Review*, 82(3), pp. 68. 78.
- ICC/ESOMAR, 2008. International Code of Market and Social Research. ICC/ESOMAR Amsterdam, the Netherlands, 4th ed. [Online] Available at: https://www.esomar.org/uploads/public/knowledge-and-standards/codes-and-guidelines/ICCESOMAR_Code_English_.pdf [Accessed: 22/11/2015].
- Jaffe, A. B., Newell, R. G. and Stavins, R. N., 2003. Technological Change and the Environment. In: K.-G. Mäler and J.R. Vincent, eds. 2003. *Handbook of Environmental Economics*. Volume 1. Amsterdam: Elsevier Science B.V.
- Jarillo, J. C., 1995. *Strategic networks*. Oxford: Butterworth-Heinemann.
- Johnson, M. W., Christensen, C. C. and Kagermann, H., 2008. Reinventing your business model. *Harvard Business Review*, 86(12), pp. 50. 59.
- Juan, Z., Wu, J. and McDonald, M., 2003. The socio-economic impacts assessment of advanced convoy driving on motorway. *Transportation Research Part A: Policy and Practice*, 37(9), pp. 731. 747.
- Kim, B. S., 2012. Measuring Technological Change . Concept, Methods, and Implications. In: A. Teixeira, ed. 2012. *Technological change*. Rijeka, Croatia: InTech Europe.
- Kim, H., Lee, J.-N. and Han, J., 2010. The role of IT in business ecosystems. *Communications of the ACM*, 53(5), pp. 151. 156.
- Kley, F., Lerch, C. and Dallinger, D., 2011. New Business Models for Electric Cars: A Holistic Approach. *Energy Policy*, 39, pp. 3392. 3403.
- Kristensen, J. P., 2011. *Why ITS needs PC*. P3ITS Webinar. ERTICO, 26 May 2011.
- Kulmala, R. and Schirokoff, A., 2009. Tieliikenteen hallinta 2015 [Road traffic management 2015], Finnish Road Administration Reports 42/2009, Helsinki. In Finnish only, English abstract.

- Leviäkangas, P. and Hietajärvi, A., 2010. Weather Information for Transport . The Value Shift. *Value World*, 33(2), pp. 4. 13.
- Leviäkangas, P. and Lähesmaa, J., 2002. Profitability Evaluation of Intelligent Transport System Investments. *Journal of Transportation Engineering*, 128(3), pp. 276. 286.
- Leviäkangas, P., 2013. Intelligent Transport Systems . Technological, Economic, System Performance and Market Views. *International Journal of Technology*, 4(3), pp. 288. 298.
- Leviäkangas, P., Aapaoja, A., Hautala, R., and Kinnunen, T., 2015. *Finnish winter road management . the evolving business ecosystem: BECSI WP2 project report*. VTT Technology 208. Espoo: VTT.
- Leviäkangas, P., Molarius, R., Könönen, V., Hietajärvi A.-M. and Zulkarnain, 2013. Devising and Demonstrating an Extreme Weather Risk Indicator for Transportation System. *Transportation Research Record, Journal of the Transportation Research Board*, 2329, pp. 45. 53.
- Leviäkangas, P., Tuominen, A., Molarius, R., Kojo, H., Schabel, J., Toivonen, S., Keränen, J., Ludvigsen, J., Vajda, A., Tuomenvirta, H., Juga, I., Nurmi, P., Rauhala, J., Rehm, F., Gerz, T., Muehlhausen, T., Schweighofer, J., Michaelides, S., Papadakis, M., Dotzek, N. and Groenemeijer, P., 2011. *Extreme weather impacts on transport systems: EWENT Project Deliverable D1*. VTT Working Papers 168. Espoo: VTT.
- Li, Y.-R., 2009. The technological roadmap of Cisco's business ecosystem. *Technovation*, 29(5), pp. 379. 386.
- Libert, B., Wind, Y., and Fenley, M. B., 2014. *What Airbnb, Uber, and Alibaba Have in Common*. Harvard Business Review, 20 November 2014 [Online] Available at: <https://hbr.org/2014/11/what-airbnb-uber-and-alibaba-have-in-common> [Accessed: 11/04/2016].
- Linder, J. C. and Cantrell, S., 2000. *Changing Business Models: Surveying the Landscape*. Chicago: Institute for Strategic Change, Accenture.
- Maccubbin, R., Staples, B., Kabir, F., Lowrance, C., Mercer, M., Philips, B. and Gordon, S., 2008. *Intelligent Transportation Systems Benefits, Costs, Deployment, and Lessons Learned: 2008 Update*. The U.S. Department of Transportation. Available at: [http://www.itslessons.its.dot.gov/its/bene-cost.nsf/images/Reports/\\$File/BCDLL-14412_full.pdf](http://www.itslessons.its.dot.gov/its/bene-cost.nsf/images/Reports/$File/BCDLL-14412_full.pdf)

- Magretta, J., 2002. Why business models matter. *Harvard Business Review*, 80(5), pp. 86. 92.
- Mahadevan, B., 2000. Business models for Internet-based e-commerce: An anatomy. *California Management Review*, 42(4), pp. 55. 69.
- Majava, J., Isoherranen, V. and Kess, P., 2013. Business Collaboration Concepts and Implications for Firms. *International Journal of Synergy and Research*, 2(1), pp. 23. 40.
- Marin, C., Stalker, I. and Mehandjiev, N., 2007. Business Ecosystem Modelling: Combining Natural Ecosystems and Multi-Agent Systems. In: M. Klusch et al. eds. 2007. *Cooperative Information Agents XI*. Berlin Heidelberg: Springer-Verlag, pp. 181. 195.
- Markides, C., 1999. A dynamic view of strategy. *Sloan Management Review*, 40(3), pp. 55. 63.
- McDonald, M., 2007. *Marketing Plans*. 6th ed. Oxford, England: Butterworth-Heinemann, p. 364.
- McQuarrie, E., 2005. *The market research toolbox: a concise guide for beginners*. 2nd ed. SAGE.
- Meyer Mohaddes Associates Inc., 2004. Evaluation of Rural ITS Information Systems along US 395, Spokane, Washington. Report prepared for the U.S. Department of Transportation ITS Joint Program Office. Available at http://ntl.bts.gov/lib/jpodocs/repts_te/13955/13955.pdf.
- Mittal, V., 2015. Qualitative Research for Customer-Focused Insights. Teaching Note, Rice University, Houston, TX 77005, November 1, 2015. Available at SSRN: <http://ssrn.com/abstract=2682846>.
- Molarius, R., Könönen, V., Leviäkangas, P., Zulkarnain, Rönty, J., Hietajärvi, A.-M. and Oiva, K., 2014. The extreme weather risk indicators (EWRI) for the European transport system. *Natural Hazards*, 72(1), pp. 189. 210.
- Moore, J. F., 1993. Predators and Prey: A New Ecology of Competition. *Harvard Business Review*, 71(3), pp. 75. 86.
- Moore, J. F., 1996. *The Death of Competition: Leadership and Strategy in the Age of Business Ecosystems*, Chichester: Wiley.

- Morris, M., Schindehutte, M. and Allen, J., 2005. The entrepreneur's business model: Toward a unified perspective. *Journal of Business Research*, 58, pp. 726. 735.
- Osterwalder, A., 2004. *The business model ontology . A proposition in a design science approach*. Dissertation 173, University of Lausanne, Switzerland.
- Osterwalder, A., Pigneur, Y. and Tucci, C. L., 2005. Clarifying business models: Origins, present and future of the concept. *Communications of the Association for Information Science (CAIS)*, 16, pp. 1. 25.
- Papakiriakopoulos, D. A., Poulymenakou, A. K. and Doukidis, G. J., 2001. Building e-Business Models: An Analytical Framework and Development Guidelines. 14th Bled Electronic Commerce Conference, Bled, Slovenia, 25. 26 June 2001.
- Peltoniemi, M. and Vuori, E., 2004. Business ecosystem as the new approach to complex adaptive business environments. In: *Proceedings of eBRF 2004*. Tampere, Finland, 2004, pp. 267. 281.
- Petrovic, O., Kittl, C. and Teksten, R. D., 2001. Developing business models for e-business. In: *International Electronic Commerce Conference*. Vienna, Austria, 31 October 2001 . 4 November 2001.
- Phillips, A., 2007. What is market research? In: C. Bont, and M. Hamersveld, eds. 2007. *Market Research Handbook*. 5th edition, West Sussex, London: John Wiley & Sons, p. 38.
- Pilli-Sihvola, E., Leviäkangas, P. and Hautala, R., 2012. Better winter road weather information saves money, time, lives and the environment. In: *Proceedings of the 19th ITS World Congress*. Vienna, Austria, 22. 26 October 2012. ERTICO (ITS Europe).
- Pilli-Sihvola, Y., 2013. Tiesääpalvelutiedon rooli liikenneturvallisuuden parantamisessa ja talvikunnossapidossa. Presentation powerpoint, ELY-keskus, 6 February 2013 [Online] Available at: https://www.ely-keskus.fi/documents/10191/338825/18_Yrj%C3%B6_Pilli-Sihvola_FIN.pdf/9ad5f1e4-5db1-4e69-a835-19d513fc5eea [Accessed: 27/11/2015].
- Porter, M. E., 1985. *Competitive advantage*. New York: Free Press.
- Porter, M. E., 1996. What is strategy. *Harvard Business Review*, 74(6), pp. 61. 78.

- Rappa, M. 2010. Business models on the web. In: *Managing the digital enterprise*. North Carolina University. [Online] Available at: <http://www.digitalenterprise.org/models/models.html> [Accessed: 29/11/2015]
- Rayport, J. F. and Jaworski, B. J., 2001. *E-commerce*. New York: McGraw-Hill/Irwin.
- Ritchey, T., 1998. General Morphological Analysis: A general method for non-quantified modeling. Swedish Morphological Society, 2002. [Online] Available at: <http://www.swemorph.com/ma.html> [Accessed: 19/01/2016]
- Rong, K., Hou, J., Shi, Y. and Lu, Q., 2010. From Value Chain, Supply Network, Towards Business Ecosystem (BE): Evaluating the BE concepts implications to emerging industrial demand. In: *2010 IEEE International Conference on Industrial Engineering and Engineering Management (IEEM)*. Macao, 7. 10 December 2010, pp. 2173. 2177.
- San Roman, T. G., Momber, I., Abbad, M. R. and Miralles, A. S., 2011. Regulatory Framework and Business Models for Charging Plug-in Electric Vehicles: Infrastructure, Agents, and Commercial Relationships. *Energy Policy*, 39, pp. 6360. 6375.
- Saunders, M., Lewis, P. and Thornhill, A., 2009. *Research methods for business students*. Harlow: Pearson Education Limited.
- Schumpeter, J., 1942. *Capitalism, Socialism and Democracy*. New York: Harper.
- Seelos, C. and Mair, J., 2007. Profitable business models and market creation in the context of deep poverty: A strategic view. *Academy of Management Perspectives*, 21, pp. 49. 63.
- Shafer, S. M., Smith, H. J. and Linder, J. 2005. The power of business models. *Business Horizons*, 48, pp. 199. 207.
- Shields, P. M. and Rangarajan, N., 2013. *A Playbook for Research Methods: Integrating Conceptual Frameworks and Project Management*. Stillwater, OK: New Forums Press.
- Slywotzky, A. J., 1996. *Value migration*. Boston (MA): Harvard Business Review Press.
- Smith, D., 2013. Navigating Risk When Entering and Participating in a Business Ecosystem. *Technology Innovation Management Review*, pp. 25. 33.

- Stevens, A., 2004. The Application and Limitations of Cost-Benefit Assessment (CBA) for Intelligent Transport Systems. *Research in Transportation Economics*, 8, pp. 91. 111.
- Stewart, D. W. and Zhao, Q., 2000. Internet marketing, business models and public policy. *Journal of Public Policy and Marketing*, 19(2), pp. 287. 296.
- Tapscott, D., Ticoll, D. and Lowi, A., 2000. *Digital Capital - Harnessing the Power of Business Webs*. Boston: Harvard Business School Press.
- Teece, D. J., 2010. Business models, business strategy and innovation. *Long Range Planning*, 43, pp. 172. 194.
- The Intelligent Transportation Society of America, 2011. *Sizing the U.S and North American Intelligent Transportation Systems Market: Market Data Analysis of ITS Revenues and Employment*. August 2011.
- The US Department of Transportation, 2005. *ITS User Services Document*, January 2005, [Online] Available at: http://ntl.bts.gov/lib/jpo-docs/repts_te/14113.htm [Accessed: 12/11/2015]
- Tian, C. H., Ray, B. K., Lee, J., Cao, R. and Ding, W., 2008. BEAM: a framework for business ecosystem analysis and modeling. *IBM Systems Journal*, 47(1), pp. 101. 114.
- Timmers, P., 1998. Business models for electronic markets. *Journal on Electronic Markets*, 8(2), pp. 3. 8.
- Vaisala, 2015. Winter Road Conditions. [Online] Available at: <http://www.vaisala.com/en/roads/applications/Pages/winterroadconditions.aspx> [Accessed: 27/11/2015].
- Vardera, L. L., 2010. *The Electric Vehicle Market in the USA*. Finpro report.
- Vaz, L. F. H., Nogueira, A. R. R., Rodrigues, M. A. de S. and Chimentí, P. C. P. de S., 2013. A New Conceptual Model for Business Ecosystem Visualization and Analysis. In: *RAC 2013*. Rio de Janeiro, Jan/Feb 2013. vol. 17, no.1, article 1, pp. 1. 17.
- Viscio, A. J. and Pasternack, B. A., 1996. Toward a new business model. *Strategy+Business*, 2(1), pp. 125. 134.

- Weigand, H., Johannesson, P., Andersson, B., Bergholtz, M., Edirisuriya, A. and Llayperuma, T., 2007. Strategic Analysis using Value Modelling . a c3 approach. In: *Proceedings of the 40th Hawaii International Conference on System Sciences*.
- Weill, P. and Vitale, M. R., 2001. *Place to space: Migrating to e-business models*. Boston: Harvard Business School Press.
- White, S. P., Thornes, J. E. and Chapman, L., 2006. A Guide to Road Weather Information Systems, version 2 (August, 2006), SIRWEC, [Online] Available at: http://www.sirwec.org/documents/rwis_web_guide.pdf [Accessed: 27/11/2015].
- Williamson, O. E., 1981. The economics of organization: the transaction cost approach. *American Journal of Sociology*, 87(4), pp. 548. 577.
- Wootton, J. R., Garcia-Ortiz, A. and Amin, S. M., 1995. Intelligent transportation systems: A global perspective. *Mathematical and Computer Modelling*, 22, pp. 259. 268.
- Xu, J., 2005. *Market Research Handbook . Measurement, Approach and Practice*. Lincoln: iUniverse, p. 22.
- Yin, R. K., 2013. *Case study research: design and methods*. 5th edition. USA: Sage Publications.
- Zheng, J., Mehndiratta, S., Guo, J. Y. and Liu, Z., 2012. Strategic policies and demonstration program of electric vehicle in China. *Transport Policy*, 19(1), pp. 17. 25.
- Zott, C. and Amit, R., 2010. Designing your future business model: An activity system perspective. *Long Range Planning*, 43, pp. 216. 226.
- Zott, C., Amit, R. and Massa, L., 2011. The Business Model: Recent Developments and Future Research. *Journal of Management*, 37(4), pp. 1019. 1042.
- Öömi, R., Innamaa, S. and Kulmala, R., 2010. Road weather information service in Finland: the impact of error probability on service benefits. In: Düh, J. et al., eds. 2010. *Data and Mobility: Transforming Information into Intelligent Traffic and Transportation Services: Proceedings of the Lakeside Conference 2010*. Berlin Heidelberg: Springer-Verlag, pp. 187. 201.

Appendix A: Reference projects

- **BECSI (Feb 2014 – Dec 2015)**

BECSI project (<http://becsi.fi/>) analyses Finnish innovation system from three perspectives: local innovation platforms, Health and Life Science ecosystems and emerging small business ecosystems. The policy level analysis is based on empirical observations from aforementioned platforms and ecosystem cases. The primary research questions are related to the cases' capability to generate economic growth and address challenges in scaling-up towards international markets. The grand idea of the project is to let the best learn from the best and to approach innovation challenges bottom-up, i.e. make true empirical investigation through observation and analysis . and with scientific criteria. My main contribution is in Work Package 2: Emerging business ecosystems.

- **MOBiNET (Aug 2013 – Oct 2015)**

The MOBiNET (<http://www.mobinet.eu/>) service platform aims to simplify the Europe-wide deployment of connected transport services by creating an Internet of Mobility+ where transport users' requests match providers' offers, and promoting openness, harmonisation, interoperability and quality. MOBiNET is a collaborative project in the 7th Framework Programme of RTD of the European Union, co-funded with a grant of almost " 11M and comprising a consortium of 34 partners including a wide range of actors and stakeholders representing the world of transport and mobility service users and providers. MOBiNET will develop, deploy and operate the technical and organisational foundations of an open, multi-vendor platform for Europe-wide mobility services. Key MOBiNET innovations address the barriers to cooperative system-enabled service deployment, including the lack of harmonised services; availability of communication means; inaccessibility and incompatibility of transport-related data; fragmentation of end-user subscription and payment services; proprietary technologies in user devices; etc. I was involved in SP5 (Pilot and Assessment) and SP6 (Organisation, Business and Social Aspects).

- **HeERO (Sep 2013 – Dec 2013)**

HeERO (<http://www.heero-pilot.eu/view/en/home.html>) addresses the pan-European in-vehicle emergency call service "e-Call" based on 112, the common European Emergency number. For three years (January 2011 to December 2013), the

nine European countries forming the HeERO 1 consortium (Croatia, Czech Republic, Finland, Germany, Greece, Italy, The Netherlands, Romania and Sweden) carried out the start-up of an interoperable and harmonised in-vehicle emergency call system. The HeERO consortium was testing and validating in real conditions pilots the common European e-Call standards defined and approved by the European Standardisation Bodies. In HeERO, I was involved in WP6 (Deployment Enablers) team.

- **EVELINA (Feb 2012 – Sep 2012)**

EVELINA project was a part of Finland's electric vehicles national test site programme that comprises several small-scale test sites in different parts of the country. My tasks in this project were conducting state-of-the-art study about EV ecosystem, including market outlook, information services, and test sites. These were part of WP4 (Information Services) and WP6 (Test Sites) activities.

- **ITS MARKET (Nov 2011 – Jan 2012)**

ITS Market-project was a small market research project supported by the Ministry of Transport and Communication Finland. This project aimed to analyse the market size, structure, and other characteristics of ITS (Intelligent Transport System) industry in Finland. The research result was presented in ITS Factory Day 2012, Tampere Finland (<https://www.youtube.com/watch?v=0XSzfyYECI4>) and in 19th ITS World Congress 2012, Vienna Austria. It was also published as a peer-reviewed scientific article.

- **EWENT (Nov 2011 – May 2012)**

The objective of the EWENT project (<http://ewent.vtt.fi/>) was to assess the impacts and consequences of extreme weather events on EU transport system. Whereas WP5 itself concerned with risk assessment of EU transportation system. My specific tasks were gathering the data as well as processing and analysing them. I was involved in the EU Project, namely EWENT, especially in WP5 (Risk Assessment).

Appendix B: Articles IËV

ARTICLE I

**Electric vehicles market outlook –
potential consumers,
information services and sites test**

International Journal of Technology 3(2): 156–168.

Copyright 2012 IJTech.

Reprinted with permission from the publisher.

ELECTRIC VEHICLES MARKET OUTLOOK – POTENTIAL CONSUMERS, INFORMATION SERVICES AND SITES TEST

Zulkarnain^{*}, Pekka Leviäkangas, Mikko Tarkiainen, Teppo Kivento

VTT Technical Research Centre of Finland, PO Box 1000, VTT, Finland

(Received: July 2012 / Revised: July 2012 / Accepted: July 2012)

ABSTRACT

The purpose of this paper is to review the most recent and relevant business intelligence and market foresight analyses on electric vehicles in order to build a picture on the current market activities and offerings. The reference material was clustered in three main sources: 1) market foresight analyses 2) information services development activities, 3) probe of electric vehicle test sites. The future EV market is seen to have a promising growth potential, though the proper business models that could meet consumer aspirations are still called for. The growing potential of EV market has been stimulating the development of several types of services that support EV deployment, e.g. information services. The test sites are already emerging around the globe and the master driver seems to be the automotive industry.

Keywords: Electric vehicles; Information services; Market; Test sites

1. INTRODUCTION

Many countries nowadays are considering what electrification of their mobility system in fact means. The purpose of this paper is to review the most recent and relevant business intelligence and market foresight analyses on the topic in order to build a picture on the current market activities and offerings.

The work was performed as part of Finland's electric vehicles national test site programme that comprises several small-scale test sites in different parts of the country. The authors gathered information from several latest market research reports and websites. The reference material was clustered in three main sources: 1) market foresight analyses 2) information services development activities, 3) probe of electric vehicle test sites. After reviewing these sources, the authors identified the foreseen information services as well as the key bottlenecks for the market acceptance of EVs. Also the test sites which were built by the automotive manufacturers, power utilities companies, and city authorities were mapped.

2. MARKET FORESIGHT

A number of studies and analyses related to electric vehicle ecosystems were conducted by several consulting companies within their reports, white papers, etc. Their studies cover many aspects of EV, i.e. market forecast, customers' feedback, infrastructure, batteries, business models, among many others.

Frost and Sullivan (2010) reported a study about overview of the EV market, indicating the development in infrastructure, business models, initiatives and consumer research. Frost and Sullivan market research entitled *360 Degree Perspective of the Global Electric Vehicle Market - 2010 Edition*, presented the following market projections:

^{*} Corresponding author's email: zulkarnain@vtt.fi, Tel. +358 40 739 3183 Fax. +358 20 722 2090

- *Urban mobility and its influence in shaping EV infrastructure;* by 2020, the emergence of mega cities in developing economies will drive personal mobility to a different level, further driving up the demand for EVs.
- *Global EV market size and forecasts;* Figure 1 shows three scenarios in EV sales forecasts for 2008 to 2015. It is predicted that by 2020, sales of EVs will comprise 4% to 12% of total car sales.

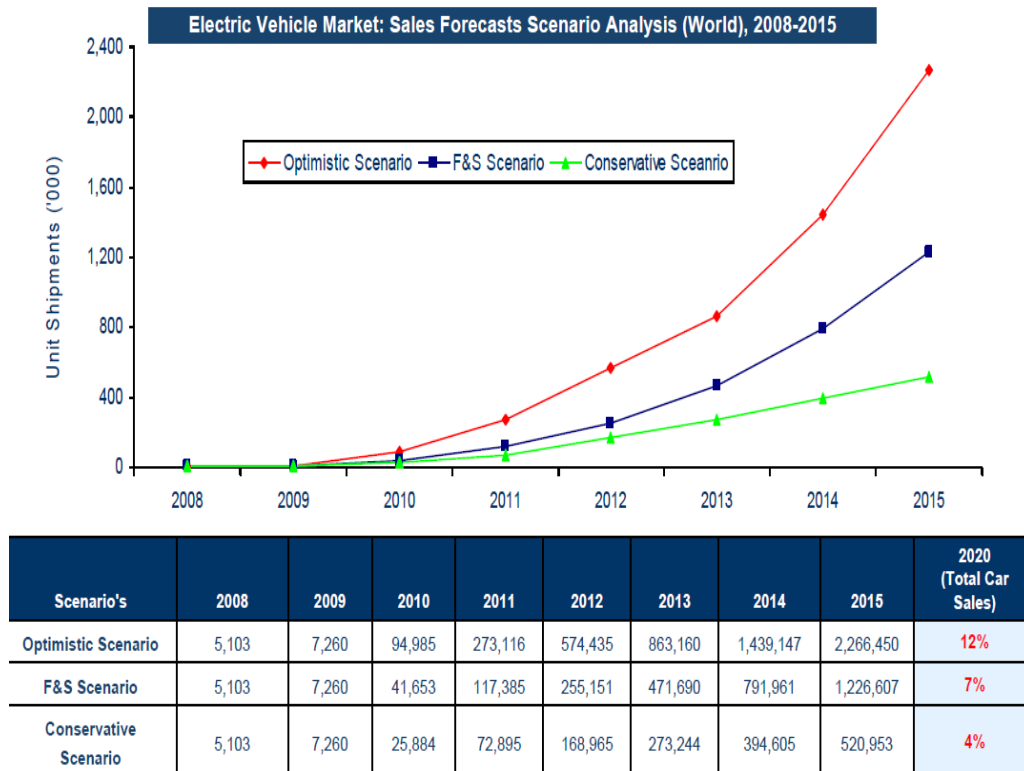

Figure 1 World EV market forecast (2008-2015)(Frost & Sullivan, 2010)

- *The preferences of the consumer;* the high price of the initial EV's will be an inhibiting factor for consumers' adoption. Price represented approximately 40% of the share of preferences for EV's demonstrating how important pricing options will be. Some other criteria for EV adopters are dominantly age (26-35 and above 55 year old), the sex (male), and income level (higher disposable income). Women showed a greater dislike for the inconvenience of charging and monitoring charge of EV's. These consumer studies were conducted in Europe. For American studies, the results are slightly different, especially with regard to the profiles of early EV adopters. In North America, early adopters are geographically located mainly in suburban areas, aged between 36-45 years, female, and with an interest in luxury cars. It was also found that environmental benefits (77% mean index), green and tech-savvy image (70% mean index) and reduced fuel cost (70% mean index) are the key adoption drivers, whereas the range anxiety and performance concerns (73% mean index), high cost concerns (70% mean index), battery concerns (69% mean index) are the key adoption restraints.
- *Business model analysis of key industry stakeholders;* the same business intelligence report identified four different business models scenarios as shown in Figure 2.

	Business Model 1	Business Model 2	Business Model 3	Business Model 4
TYPE	Energy Package	Maintenance Package	Part Subsidy	Full Subsidy
COVER	Partial battery lease + Electricity	Energy Package+ Insurance+ Maintenance	Maintenance Package+ Discount	Maintenance Package+ 100% Discount
ENERGY	Monthly Bill	Flat: Max 1250 miles/month	Flat: 15,500 miles/year	Flat: ~18,500 miles/year
CONTRACT	NA	NA	4 years	7 years
SUBSIDY	NA	NA	50% car price	Free car
MONTHLY LEASE	Up to \$225	Up to \$500	\$750- \$1100	~ \$1350- \$2250

Other Possible Leasing models			
Flexible Mileage	Unlimited Miles	Max number of miles	Pay as you go
Flexible Contract	The customer opts for the number of years and flexible mileage- customized lease		

Figure 2 Business models analysis (Europe), 2009(Frost & Sullivan, 2010)

Another analysis is coming from Finpro (2010), which has also investigated EV ecosystem. Finpro’s findings were the following:

- Key enablers for the market acceptance of EV’s are costs (competitive products available), battery (e.g. range and reliability) and infrastructure.
- Electric vehicles ecosystem (or value chain) involves new actors. For the EV industry to succeed, new kinds of cooperation models are needed - not just the traditional partnerships between original equipment manufacturers (OEMs) and suppliers, but also with the players outside the automobile industry, such as utilities, and charging station manufacturers. A more active role of governments is needed as well (Figure 3).

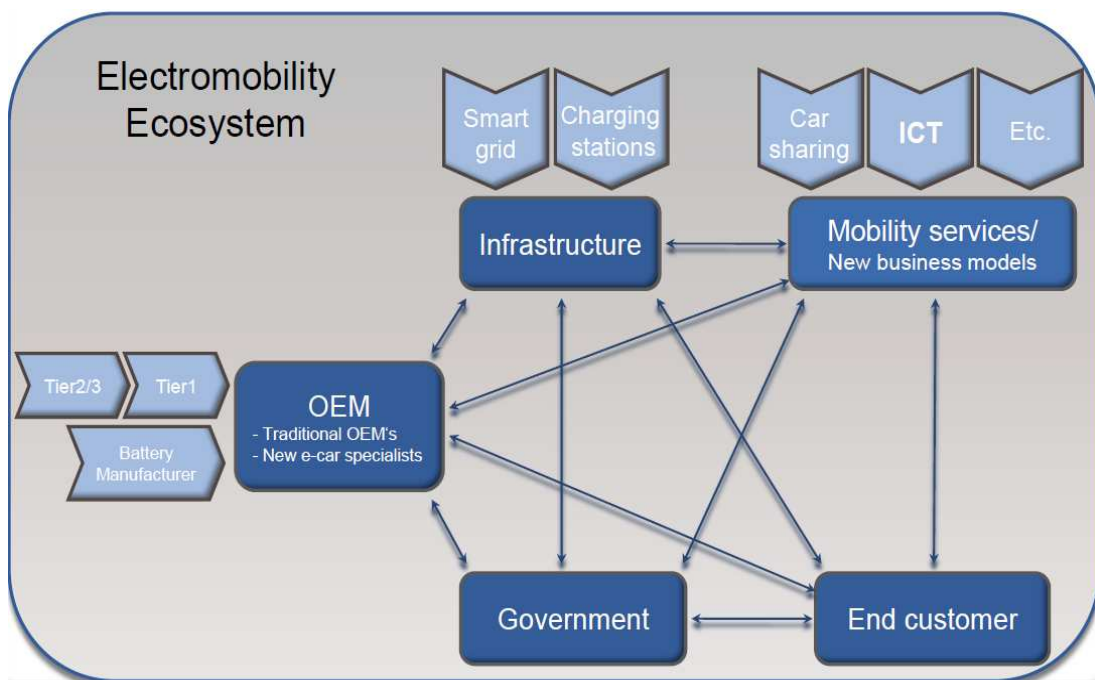

Figure 3 Electric vehicles ecosystem(Finpro, 2010)

- The whole picture for the future electromobility is still unclear, and the market predictions are partly contradictory as well as the opinions about the winning technology (e.g. battery electric vehicle vs. fuel cell).
- Electromobility will thoroughly shake up the automotive industry by creating many opportunities for innovative companies, but also will pose serious risks for both established and new players.
- There is uncertainty concerning earning logics – business models within electromobility can somewhat be foreseen, but a sharp picture is still missing.
- Standardization at European and global levels is needed for technology and preparing of the market for electric vehicles.

Catalyst Strategy Consulting with partnership of MEC Intelligence (2011) have presented some inhibitors and drivers for deploying EVs, based on data gathered from test fleet of electric vehicles, which was driven by families and public officials over a period of 12 months (2009-2010), in Copenhagen, Denmark (Figure 4).

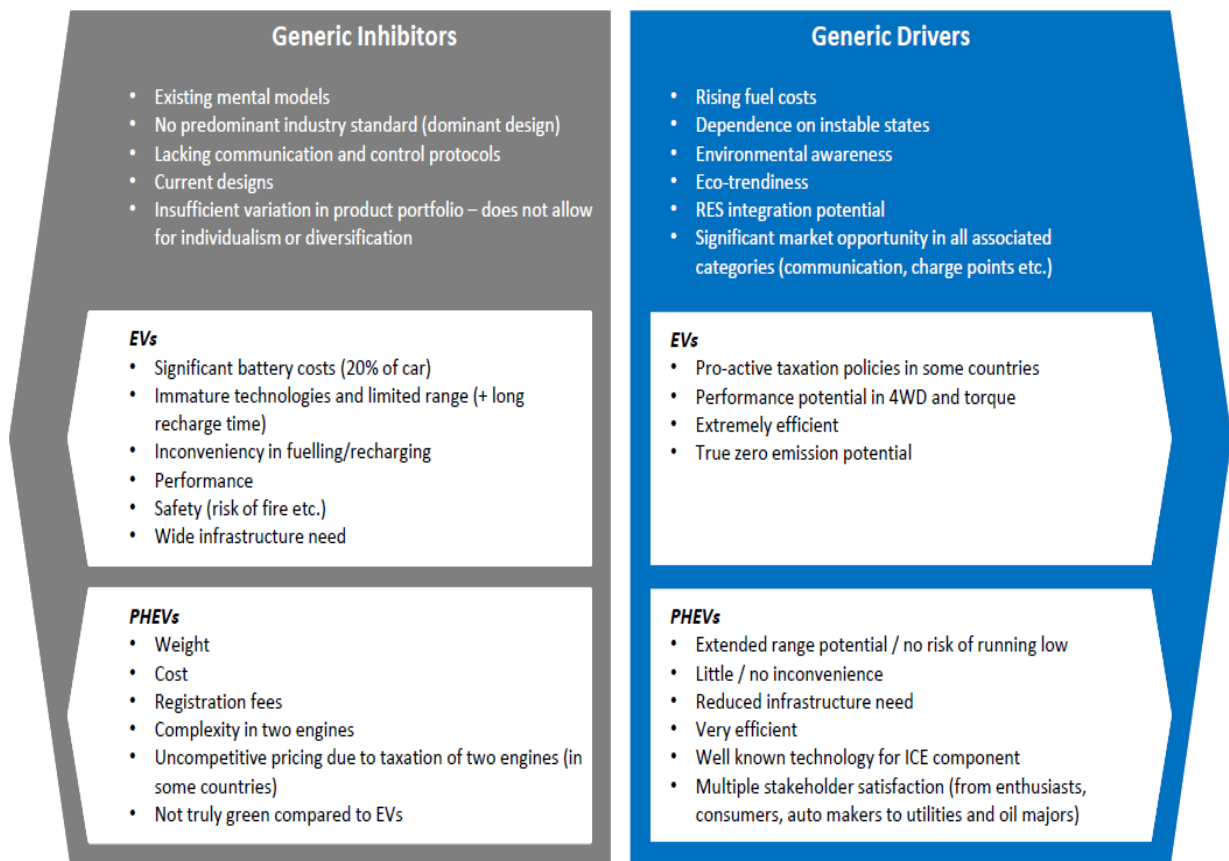

Figure 4 Overall assessment of main drivers and inhibitors of Electric Vehicles(MEC Intelligence, 2011)

Data Monitor consulting firm studied the market trends for hybrid and electric cars in the largest European automotive markets, namely France, Germany, Italy, Spain, and UK (Data Monitor 2011). Some aspects included in the study are the market trends and consumer

insights. Based on this survey, the majority of respondents are willing to buy a hybrid/electric car, with a similar degree of willingness expressed among various demographic groups. Across the top five markets, initial purchase price, after-sales service, and running (fuel) costs are the most important criteria when buying a new car. The major drivers for the purchase of hybrid/electric cars are low running (fuel) costs, a low carbon footprint, and government incentives. Despite government incentives being one of the major drivers for the purchase of a hybrid/electric car, in all the top five markets except in Italy, the majority of respondents are not aware of these government incentives. Otherwise, across the top five European countries, concerns regarding charging infrastructure, after-sales services, initial purchase prices, and perceived high recurring costs are the major inhibitors for the purchase of hybrid/electric vehicles.

3. INFORMATION SERVICES DEVELOPMENT

3.1. Business intelligence sources

Several studies have been conducted to identify what kind of information services related to electric vehicles would be needed in order to speed up the EV deployment. Frost and Sullivan (2009) identify the EV telematics package that contains Point of Interest (POI) package and navigation package that are believed to be crucial to reduce range anxiety and range conservation (Figure 5). Other potential services for the EV drivers are monthly EV miles report generating, entertainment on-demand-information, remote vehicle diagnostics and interior pre-conditioning.

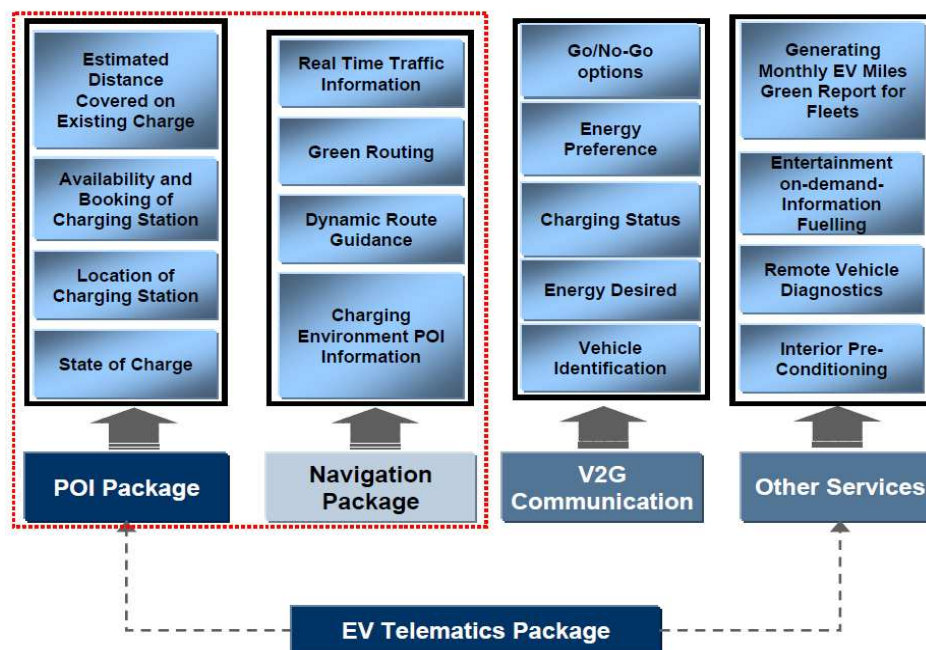

Figure 5 Telematics market for electric vehicles: services overview for Europe and North America(Frost and Sullivan, 2009)

SBD (2010) views that there are two main ways the EV telematics services could be implemented (Table 1). The first one is over-the-air telematics which replicates existing telematics services that use a cellular connection (either using an embedded phone module or via a Bluetooth connection to the user's mobile phone) to send data to and from the car. Secondly, there is a plug-in telematics which utilises charging connectivity that may be physically linked to a communication network, to send data to and from the car based on smart-

grid. SBD (2010) also points out that the smart grid could facilitate two-way communications – for this purpose, Advance Metering Infrastructure (AMI) is needed. Some examples of undergoing cooperation related to the AMI are the e-mobility Berlin project (Daimler and RWE), Mitsubishi and JDS i-charger AMI programme, Nissan and General Electric in the United States, etc.

Table1 The overview of telematics use cases and challenges for EVs (SBD, 2010)

EV telematics approach		Key use cases	Challenges
Over-the-air telematics	Delivering services remotely via a cellular network	<ol style="list-style-type: none"> 1. Charging status info 2. Charging station info 3. Charging billing services 4. Remote diagnostics 5. LBS services 	<ol style="list-style-type: none"> 1. Most services require embedded SIMS 2. Telematics value chain is still immature
Plug-in telematics	Delivering services via the charging plug whilst the car is physically connected	<ol style="list-style-type: none"> 1. Optimised charging 2. Automatic payments & billing 3. value-added services 	<ol style="list-style-type: none"> 1. Different communication standards for different regions 2. Most charging stations and homes unlikely to be connected to a smartgrid for the foreseeable future

3.2. Automotive manufacturers' offering of information services

Several in-car telematics services are being developed by some vehicle manufacturers. The first example is Nissan Leaf with its telematics services namely Carwings. It provides services to the driver including information about state of charge, estimated distance with current charge, nearest charging station information and hours left until the battery is full when charging. The driver could also pre-schedule a charging time and turning on of the air conditioning system, among other services.

GM Volt is using its OnStar application in providing telematics services to the driver. Several services offered are not too different with Carwings. Navigation services as well as battery charging monitoring are delivered by this application. Charging status, charging mode, lock/unlock, remote air conditioning control are also provided.

Quite similar to the abovementioned, several basic telematics packages are offered by other vehicle manufacturers like Renault Zoe with its R-link, Peugeot iOn with its Peugeot Connect services, Ford Focus electric with its Airbiquity, MyFord Touch ®, and SYNC, etc. Table 2 shows several examples of over-the-air/ in-vehicle telematics services. However, several electric car manufacturers like Th!nk city, Reva, or Tesla roadster do not offer special applications or dedicated telematics packages besides the basic crucial information in the vehicle dashboard that are needed to operate EVs.

Car manufacturers are also seeking new partnerships and cooperation with other stakeholders in order to provide innovative information services that have a broader scope. For example, GM together with utilities, energy companies and technology firms will release smart grid Application Programming Interfaces (APIs) for integrating EVs with smart grid technology.

The smart grid APIs will be focused on several developed solutions including (Telematic News, 2012):

Demand response – This solution connects utilities to companies that have intelligent energy management products. These companies can use OnStar to manage energy use for Volt customers who opt in for the service. This future service allows the customer to save money in energy costs while enabling more efficient use of the electric grid.

Time-of-use (TOU) rates – OnStar can receive dynamic TOU pricing from utilities and notify Volt owners of the rate plan offers via email. Owners will be able to use OnStar to load the rate plans directly into their vehicle and access them to schedule charging during lower-rate periods.

Charging data – OnStar also sends and receives EV data to/from power suppliers. This includes location-based EV data that identifies charging locations and determines potential load scenarios.

Aggregated services – This solution allows electric service providers to manage the charging of participating vehicles in a given geographic area, after customer consent. This includes the ability to control charging on a large amount of EVs simultaneously. OnStar recently showcased these capabilities on Google's "Gfleet", where a Volt would receive a renewable energy signal provided by an energy management company, opening up the potential to alert EV customers when renewable energy is available on the grid for charging.

Car manufacturers are gradually opening their in-vehicle and telematics data for third party developers. This is not restricted to electric vehicles but there is a need to boost telematics services for all vehicles. For instance, General Motors have also opened access to OnStar (GM's telematics service suite available in the US, Canada and China) to selected developers via proprietary Application Program Interface (API) to create innovative mobile applications (GM, 2012). Car manufacturers are able to provide vehicle data via their telematics system by opening a data interface usually to selected partners. Application developers may have an access to multiple telematics systems and hence provide the same service for several vehicle brands.

One of the first third party mobile applications for electric vehicles is GreenCharging app, which can connect to Nissan's Carwings and General Motors' OnStar services and retrieve accurate state-of-charge information about Nissan Leaf or Chevrolet Volt (Greencharge, 2012). Another approach comes from Ford that has launched together with Bug Labs an Open-Source R&D Platform called OpenXC. OpenXC is an open source hardware and software stack allowing third parties to connect to an OpenXC-compliant Ford car and read a limited set of vehicle data with an Android device. OpenXC platform will be officially released in 2012. (OpenXC, 2012).

One of the basic information services, which is offered to electric vehicle drivers usually by the vehicle manufacturer, is the location of the charging points. This information is provided via in-vehicle navigation system where charging points are one of the key destinations similar to other POIs. Location of the charging points is collected and integrated into digital maps by the map provider of the in-vehicle navigation system. For example, NAVTEQ has collected already in 2011 over 5,000 verified EV charging locations throughout Europe. The charging point data includes information on location, private access, connector- or power feed types, the number of connectors, and opening hours and payment methods. As the EV market expands, more dynamic information such as availability of a specific charging port at a specific time will be included (NAVTEQ, 2011). In the Nordic countries the collection of available electric vehicle charging locations is currently being collected into a common database from which the data will be open and freely available for developers as well as for map providers (Norden, 2012).

Table2 Examples of EV telematics from car manufacturers

Vehicle manufacturers	EV telematics services	Services offered
Nissan Leaf	Carwings	Estimated distance in current charge; climate control; fully-charged notification by email; timer function for charging
GM Volt	Onstar	Navigation, Battery charging monitoring, charge status, remote climate control
Renault Zoe	R-link	Includes a host of new functions dedicated to electric motoring and range management: histogram of energy consumption, display of energy flows and pre-programming of battery charging. The navigation system offers bespoke services such as a display of the vehicle's operating radius based on the range remaining in the battery, suggestions for the most energy-efficient itineraries and the location of nearby battery charging stations (depending on country), as well as their real-time availability. R-Link also lets drivers view their eco-driving performance and improve their technique with 'eco-scoring' and tips
Peugeot iOn	Peugeot Connect services	Peugeot Connect Fleet: Battery charge status, remaining range of vehicle, mileage before the next service, etc. Including Peugeot Connect SOS and Peugeot Connect Assistance for emergency or repair services.
Citroen C-Zero	Citroen eTouch	Includes two services on-board: Citroen localised assistance calls and Citroen localised emergency calls.
Ford Focus electric	Five -way buttons on the steering wheels; MyFord Touch®; SYNC; Airbiquity	Battery charger status, distance to the next charging stations, navigation, EcoRoute, climate control, entertainment
Toyota (Prius, RAV4 EV)	Owner's navigator, eConnect, Toyota Friend, Battery care and checking, Charging service.	Vehicle status (battery power and EV range), locations of nearby charging stations, etc.
Others: VW E-up, Daimler (Smart fortwo ed, Mercedes SLS E-cell), Mitsubishi i-MiEV, Audi E-tron R8, Fiat 500 E, Honda Fit EV, Th!nk city, Tata Indica Vista EV, Tesla (Roadster, Model S Signature),Reva (G-Wiz). There is no specific information available through websites concerning these manufacturers' EV telematics services.		

Telenor Connexion has been chosen as the European connectivity supplier for Renault's sophisticated telematics services available on new Renault electric and fuel vehicles. Telenor Connexion's dedicated connectivity solution helps Renault's sophisticated on-board unitto connect to the Renault Global Data Center in a private network environment, allowing Renault

to provide its end customers with a wide range of services and information. This is made possible by seamless communications via cellular mobile networks in all of Europe, plus Russia and Turkey (Telenorconnexion, 2011).

Another set of services related to EVs are emergency charging services. The automobile club AAA (the American Automobile Association) plans to deploy mobile charging units for battery-electric vehicles. AAA already has at least one working unit and plans to post additional vehicles in California, Florida, Georgia, Oregon, Tennessee and Washington. Roadside assistance trucks will have Level 2 and Level 3 chargers, offering 240 volts and 500 volts of alternating current, respectively (Bright Sight Of News, 2011).

4. ELECTRIC VEHICLES TEST SITES

In the coming years the sales of EVs are expected to increase and seeing an EV in the traffic will become an everyday experience. With this development comes also a need to ensure that the EVs can be charged effortlessly on all charging posts regardless of car brand, EV service operator or power producer. The users will experience that charging and billing occurs seamlessly across operators and geographical areas. To ensure that all players experience true *interoperability*, a national test centre is founded in Denmark. To test the concept and obtain experiences with the first EV operators, the Nordic EV Interoperability Centre (NEVIC) will perform initial test procedures and demonstrate the concepts during late 2011, and first months of 2012. The new NEVIC will have both fast charging and standard charging facilities supplied by various service providers.

Many countries and regions over the world nowadays have conducted some test sites for electric vehicles deployment. These test sites for electric vehicles are implemented to monitor and evaluate the whole electric vehicles ecosystem performance, including vehicles, infrastructures, users, governments, etc. before massive implementation is employed.

Several regions in the United States are already implementing EV test sites, e.g. Greenville, Kearney, Dallas, Auburn Hills, and New York. General Electric (GE) has chosen Greenville as EV test city. There are more than 40 GE electric vehicle charging stations that will be installed at hotels, the Greenville–Spartanburg International Airport, downtown businesses and other locations. In addition, more than 10 electric vehicles will be delivered to a rental fleet. GE will also be launching a membership–based car sharing program, namely WeCar, in downtown Greenville using electric vehicles.

The Nebraska Clean Cities – Coalition has selected Kearney as a pilot community to introduce electric cars and charging stations in Nebraska. Kearney will become a model community for electric vehicles development. The next city participating in EV test site is Dallas, which plans three pilot programs that includes providing cars, charging stations, and free electricity. For the third program (providing free electricity to public), the city council still is still considering options.

One of the large car manufacturers, the Chrysler Group, in partnership with the US Department of Energy, will deliver four demonstration plug-in hybrid electric pickup trucks in the city of Auburn Hills, Michigan. This demonstration program is part of a national demonstration fleet of 140 vehicles during the next three years to evaluate customer usage, drive cycles, charging, thermal management, fuel economy, emissions, and impact on the regions' electric grid.

Finally, New York City will participate to test battery electric vehicles (Nissan Leaf) in taxi fleet in 2012. There are six cars that would be tested in this pilot program, to study how electric – drive vehicles perform in the largest US taxi fleet.

In Germany, a logistic company that is providing postal and parcel delivery services will test Fiat 500 E electric vehicles. Whereas in Hanover, Volkswagen tested seven electric city vans, VW Caddies for two years in field trials.

In France, a new public electric cars scheme namely Autolib' has been applied since December 2011 in Paris. Autolib' is an electric car rental service that provides the users with 24/7 transport services in French capital and surrounding cities. To use this service, the users simply have to hold a driving license and subscribe to the service at the station. There are 250 stations located in Paris and 3,000 cars will eventually be available by 2012. Furthermore, French carmaker Renault has opened a new EUR28m electric vehicle test facility in Lardy, France, which houses most of the test facilities for electric motors and batteries. Renault has also opened the Renault ZE (Zero Emission) Centre in Boulogne-Billancourt, the first such center to be opened in Europe by a vehicle manufacturer. The center aims to share the ZE experience with all visitors by demonstrating Renault's EV offering and its ambitions in electromobility.

In Sweden, Test Site Sweden (TSS) will create world-class demonstration and testing environments for next generation of vehicles and transport infrastructure. They will deploy two [CHAdeMO](#) fast charge stations in the Gothenburg area and perform tests with EVs. The purpose is to establish a test environment that is open for organizations that have a need of testing EV fast charging stations.

Several countries in Asia-Pacific region like China, Singapore, Japan, Philippines and Australia have also participated in EV testing. In China, Honda has begun demonstration testing of its Honda Fit EV in the city of Guangzhou, whereas Volvo cars chose the city of Shanghai to test its C30 electric cars. An infrastructure of over 13,000 charging stations and 15 battery swapping stations is being built there. Furthermore, Zheng et al., (2012) conducted a survey among 13 pilot cities in China that have participated in electric vehicle demonstration programs. Table 3 shows the Alternative Fuel Vehicle (AFV) deployment plan in the 13 pilot cities in China.

Singapore has also launched its electric vehicle test bed involving three outdoor and two indoor charging stations. The first batch of EVs comprises five Mitsubishi i-MIEVs and four smart Electric Drive (ed) Daimler vehicles. A partnership is established between the Land Transport Authority (LTA), Ministry of Manpower (MOM), Mitsubishi Corporation and Senoko Energy. The test bed aims to gain better understanding of EV technologies, business models, and user preferences.

In Japan, Saitama city has a total of 57 EV charging station to test the EV infrastructure. This test aims to gather information about how often each station is used, how often each user charges their car, how much power is needed by each station, etc. Hitachi Solutions, NTT Data and NEC are participating in providing the monitoring system.

An electric vehicles test site for public transport is operated in Makati City, Manila (Philippines). There are 21 electric jeepneys, each accommodating 14 passengers, to be lunched there.

Australia has also tested 20 electric cars in Hunter and Sydney. There are fifty-six charging stations being installed for the trial. Moreover, Florianopolis city in Brazil will become the test city for the electric automobile Hiriko. Hiriko was first launched in January 2012 in Brussels as an example of sustainable mobility. Figure 6 shows these EV test site examples in one glance.

Table 3 AFV deployment plan of the 13 pilot cities (Zheng et al., 2012)

City name	Number of AFVs (by year)	Vehicle type	Services fields
Beijing	1000 (2009); 5000 (2012)	HEV and PEV, considering FCV	Buses and sanitation vehicles
Shanghai	4157 (2012)	N/A	N/A
Chongqing	2550 (2012)	HEV (Gasoline Electricity Hybrid Vehicle and Natural Gas Electricity Hybrid Vehicle)	Buses, taxis, official-duty vehicles and passenger cars
Changchun	1000 (2012)	HEV and PEV	Buses, official-duty vehicles
Dalian	1200 (2010); 2400 (2012)	HEV, PEV and FCV	Buses, taxis, official-duty vehicles and passenger cars
Hangzhou	3000 (2012)	N/A	N/A
jinan	1600 (2012)	HEV and PEV	Buses, taxis, official-duty vehicles, sanitation vehicles, postal service vehicles, tourist buses
Wuhan	2500 (2012)	HEV and PEV	Buses, taxis, official-duty vehicles and passenger cars
Shenzhen	More than 800 buses (2010); 24,000 AFVs (2012)	HEV and PEV	Buses, taxis, official-duty vehicles, business vehicles, passenger cars
Hefei	1400 (2012)	PEV	Buses, taxis, official-duty vehicles
Changsa	4570 (2012)	N/A	N/A
Kunming	1000 (2012)	HEV, considering PEV	Buses
Nanchang	1100 (2012)	HEV and PEV	Buses, taxis, official-duty vehicles, postal service vehicles, sanitation vehicles.

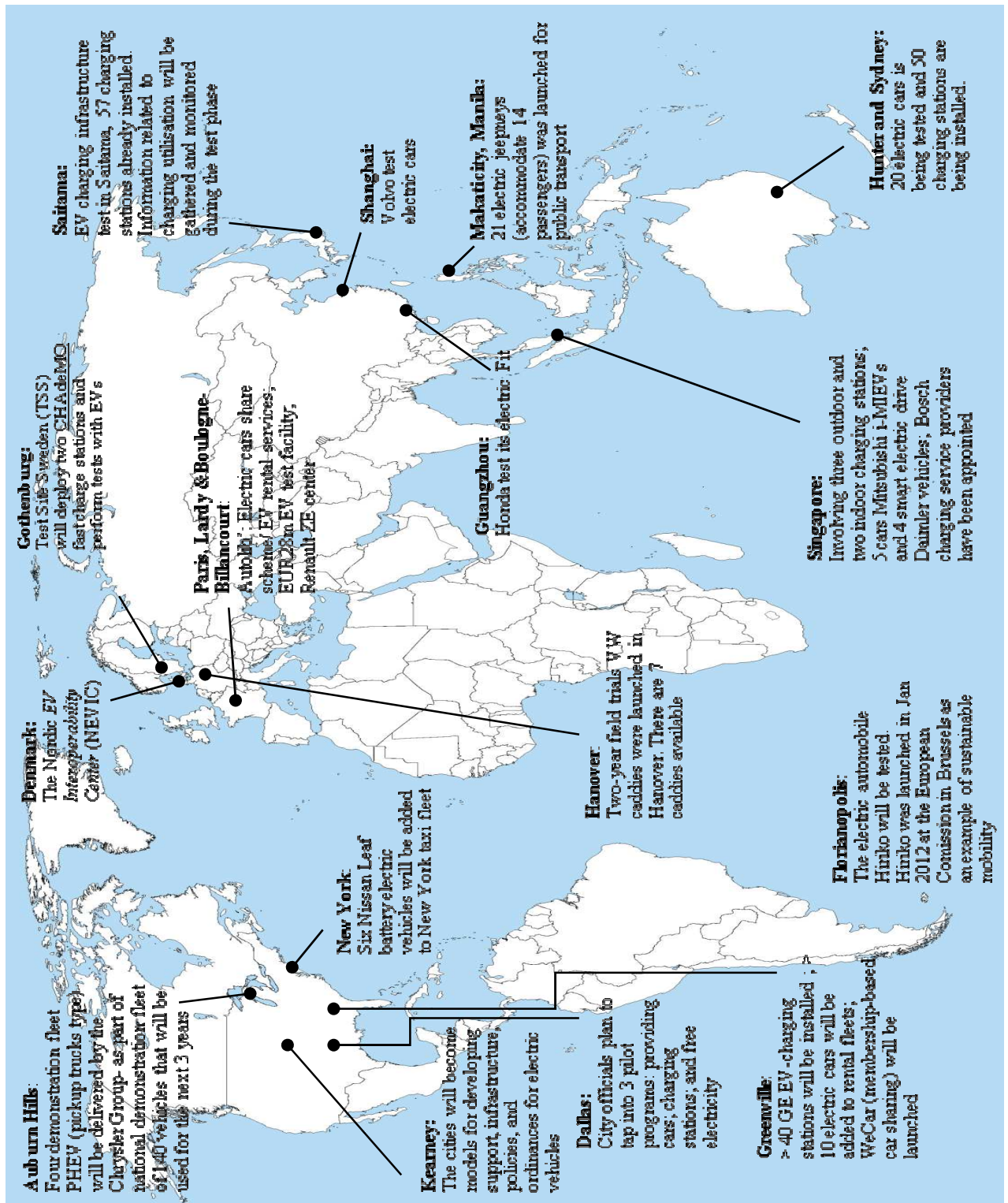

Figure 6 EV test sites examples

5. CONCLUSION

Clearly the business intelligence and market foresight analyses provide a picture of a vivid and active EV industry in its infancy. The test sites are already emerging around the globe and the master driver seems to be the automotive industry, which is not a surprise. Two other keen actors are the battery suppliers and energy utilities, particularly those who own their networks and not only the production facilities. Both the automotive sector and the utilities have a strategic expansion potential in the value network of EVs.

The market actors' work in developing novel service concepts and demonstrating them in their test sites is already running at full speed. Once the market penetration starts to take place for real, these early actors are in the best comparative position – provided that they have been able to successfully pilot their own concepts.

6. ACKNOWLEDGEMENTS

Support from VTT Graduate School and National Technology Funding Agency (Tekes) are acknowledged.

7. REFERENCES

- Bright Sight Of News. 2011. *AAA pioneers mobile electric vehicle charging services*. available on: <<http://www.brightsideofnews.com/news/2011/8/1/aaa-pioneers-mobile-electric-vehicle-charging-services.aspx>> [accessed on June 1st 2012].
- Data Monitor, 2011. *Hybrid and Electric Car Market in the Biggest European Automotive Markets: Trends, Consumer Insights, and Future Outlook*, January 2011
- Frost, Sullivan, 2009. *Strategic market and technology assessment of telematics applications for electric vehicles*.
- Frost, Sullivan, 2010. *360 Degree Perspective of the Global Electric Vehicle Market - 2010 Edition*
- GM, 2012. Calling All Developers: OnStar Looking for Next Big App. available on: <http://media.gm.com/media/us/en/onstar/news.detail.html/content/Pages/news/us/en/2012/Jan/ces/0108_onstar_api.html> [accessed on May 25th 2012]
- Greencharge, 2012. GreenCharge - Take control of your electric car. available on: <<http://www.greenchargeapp.com/>> [accessed on May 25th 2012]
- Koskue, M., Talka, M., 2010. *Electric Vehicles*. Finpro report, 25 November 2010
- MEC Intelligence, 2011. *Drivers and Inhibitors of Electric Vehicles: Based on data from a live test fleet of electric vehicles*. Report, December 2011
- NAVTEQ, 2011. NAVTEQ's Latest Press Releases: NAVTEQ Adds More Electric Vehicle (EV) Charging Locations to Its Extensive Green Content Portfolio. available on <<http://press.navteq.com/index.php?s=4260&item=26578>> [accessed on May 25th 2012]
- Norden, 2012. Mapping electric fuel stations. available on: <<http://www.nordicenergy.org/project/mapping-electric-fuel-stations/>> [accessed on May 25th 2012]
- OpenXC, 2012. available on: <<http://openxcplatform.com/>> [accessed on May 25th 2012]
- SBD, 2010. An overview of opportunities and challenges for EV telematics. White paper
- Telematics News. 2012. GM releases Smart Grid APIs for Chevy Volt, via OnStar. available on: <http://telematicsnews.info/2012/02/03/gm-releases-smart-grid-apis-for-chevy-volt-via-onstar_f3032/> [accessed on April 4th 2012]
- Telenorconnexion, 2011. New Renault electric and ICE cars connected through Telenor Connexion, available on: <<http://www.telenorconnexion.com/news/new-renault-electric-and-ice-cars-connected-through-telenor-connexion#more-3336>> [accessed on June 1st 2012]
- Zheng, Jie et al., 2012. Strategic policies and demonstration program of electric vehicle in China. *Transport Policy* 19, 17-25

ARTICLE II

**The size, structure and characteristics
of Finland's ITS industry**

Technology and Investment 3(3): 158–167.

Copyright 2012 SciRes.

Reprinted with permission from the publisher.

The Size, Structure and Characteristics of Finland's ITS Industry

Zulkarnain, Pekka Leviäkangas

VTT Technical Research Centre of Finland, Oulu, Finland

Email: zulkarnain@vtt.fi

Received June 6, 2012; revised June 25, 2012; accepted July 2, 2012

ABSTRACT

Intelligent transport systems (ITS) are seen as a high-growth segment within the transport sector, as information and communication technologies (ICT) push their way through different industries. ITS products and services has been developed, and its myriad benefits has been introduced which are promising for new business opportunities and investors. Its economic importance has also been recognised as well and many analyst reports show significant growth projections for the ITS market as a whole. This paper attempts to make the first quantitative and empirical analysis of the ITS industry in Finland. The Finnish ITS market had a significant growth in 2007 but has since then been very slowly been turning upwards from the negative growth observed in 2008 and 2009. The fast growing firms have clearly been showing good growth, whereas the weakest performers seem to have a continuous declining trend. The Finnish ITS supply market had an aggregate turnover of approximately €300 million and around 1700 employees in 2010.

Keywords: Intelligent Transport Systems; Market; Growth; Industry; Industry Structure; Finland

1. Introduction

Rapid development of information and communication technologies (ICT) has introduced many changes to various sectors. It has transformed most industries as well as public sector from education to health care, and is now in the early stages of transforming transport systems [1]. Intelligent transport systems (ITS) are the systems that utilize ICT in the transport system, covering all modes of transport for both passengers and goods. ITS brings significant improvement in transport system performance, including reduced congestion, increased safety, and traveller convenience through products and services such as navigation devices and services, automatic warning systems and communications services between drivers and the environment, just to name a few of the typical.

ITS is regarded as a tool for transportation system designers to improve the aforementioned characteristics of the system. It has also been introduced as a mean to reduce emissions from the transportation system, hence greening the system. The benefits of ITS have been studied widely. Kristensen [2] pointed out the ITS could reduce as much as 50% of the congestion societal costs 3 billion € per year in the EU, equaling about 1% of the region's GDP. Moreover, there are about 800 fatal accidents per year in the Netherlands (total EU about 40,000) yielding to ca. € billion cost to the Dutch society (about 3% of GDP)—with the help of ITS even 25% decrease in

these costs could achieved [2]. There are about 200,000 premature deaths per year in the EU because of poor air quality, since transport generates about 25% - 30% of greenhouse gases. These harmful effects can be reduced by ITS by about 15%. Ferreira [3] showed about potential of ITS for road transport. ITS could make reduction of congestion by 5% - 15%; 5% - 15% less fatalities and 5% - 10% less injuries; and possible savings of 10% - 20% CO₂ emissions. In Leviäkangas and Hietajärvi [4] the weather-related ITS services were listed with almost equally impressive impacts.

The benefits of ITS can be realised only after there are services that are delivered to and utilised by transport system users, regardless of the mode and whether private, corporate or institutional users of the services are considered. The service supply chains from observation to dissemination need to be constructed appropriately and it is not self-evident that these service supply chains can be built easily [5]. Neither is it obvious that service supply chains are emerging even when the demand for services is evident.

But without question, ITS has already rightfully taken its place in the tool box of decision makers and transport system engineers and there is in fact little doubt that the best of ITS can deliver significant benefits. Its economic importance has been recognised as well and many analyst reports show significant growth projections for the ITS market as a whole. Most importantly, the stronger

and more competitive the ITS industry from the supply side is, the more there is potential for benefits.

The ITS market growth has seen to possess great potential for the years to come. Based on BCC research [6], there will be strong growth for ITS device market. The worldwide market is valued at 24 billion US\$ in 2010, and it is expected to increase at a 22.2% compound annual growth rate during the forecast period to reach a value of 65 billion US\$ in 2015. Besides, according to Kristensen [2], between years of 2000 to 2010, EU market for ITS equipment and services increase from 1 to 21 billion € per year. These aforementioned projections are based on market researches, the data of which are not transparent nor explained thoroughly, however, and hence they should be viewed critically. Yet, ITS is regarded as a fast growing sector with lots of promises—and not only concerning the benefits it is expected to deliver but also in terms of pure economic growth.

There is a solid justification for the use of ITS and it has been widely adopted globally and furthermore, the ITS cluster has been recognised as an industry of its own right. However, the size and the structure of the market vary from region to region, and from country to country, as the technological advancement and purchasing powers of the countries/regions differ significantly from each other.

This paper attempts to make the first quantitative and empirical analysis of the ITS industry in Finland, known as one of the high-tech societies in the world, ranked sixth by the World Economic Forum [7]. The home nest of Nokia has been seeking new “Nokias”—as the old one moves towards more mature phase of its evolution path—to boost national economy and to create new seeds of growth. Our paper aims to deliver critical, yet analytical information for several stakeholders. First, the Finnish industry policy makers and ITS business developers will hopefully view the data with a keen eye and build their perception of the ITS industry in Finland. Secondly, the analysis tools and approaches presented in this paper should be of generic interest to ITS community. ITS has long been the “wishing well” for both business developers and transport policy makers. This paper attempts to quantify the foundation of the expectations and hence bring in a more realistic view on the industry.

An early version of this paper is to be presented in ITS World Congress 2012 in Vienna, Austria.

2. Purpose and Scope

The first purpose of this paper is to describe the ITS market structure from the supply side. The demand side of the market, *i.e.* those consumers, corporate customers and authorities that demand ITS services and products for their own and for public good is not within the scope of this analysis although it clearly is more than tightly

connected to the supply side. The supply side consists of companies that deliver these services and products. Supply side represents the “true” size of the market as it is observed since it can be assumed that the aggregate turnover these companies also meets the minimum demand: if there would not be true demand, there would not be any turnover, obviously. The observed supply, however, does not reveal whether there is any unsatisfied demand for ITS products and services. The first logical assumption is that there is always to some extent this type of unmet demand. The structure of the market will be described by positioning the companies that supply ITS in an industry value chain constructed particularly for this study. The value chain structure follows the traditional principles that of Porter [8].

The size of the market is simply the summed turnover of the companies since this figure represent the total value of ITS goods and services provided after demand. The companies’ selection—which companies can be regarded as “ITS companies”—is then not an equally straight-forward question. We created a set of criteria to select the companies but some important firms were still left out from the included group. This definition is identical to the definition “the total market size is the total value of sales”. The aggregate supply, *i.e.* the sales, of the sector representing the size of the market relies on traditional microeconomics concepts (see any standard microeconomics text book, *e.g.* Eaton *et al.* [9] or Pindyck and Rubinfeld [10]).

Thirdly, the growth trend of the ITS market is approximated with the help of a smaller sample of companies which can be considered as 100% ITS focused entities. By selecting this kind of sample we try to exclude the noise of other growth trends than that of ITS as those companies that have several other business segments alongside ITS would distort the ITS growth trend.

Fourth, the Finnish ITS market characteristics are qualitatively explained from several perspectives, yet basing the explanations on the quantifiable parameters of the companies belonging to the ITS cluster. We will assess characteristics like completeness of the industry value chain, concentration ratios (how scattered or concentrated the cluster is), and employment effects. Finally, we will provide an estimate of the ITS market in relation to GDP in Finland and point out how significant the industry is now and what is its prospective importance in the future economy.

Our analysis excludes the “intermediate” roles in the service supply chain as explained in Leviäkangas [5]. Thus the role of network operators is left out. These companies do develop also ITS related services but in reality we could not detect these offered in the market to any significant extent in Finland and hence we stuck to our exclusion decision. Their role in the future is, how-

ever, discussed in the concluding chapter. Moreover, even if these services existed, their value would be extremely difficult to extract from other revenue sources.

In this paper, the definition of “ITS industry” is holistic and somewhat subjective since ITS in itself does not have definite boundaries. What we have explicitly excluded from our sample are the operators’ services related to ITS and consultancy related to supply chain management. The latter also represents somewhat significant consultancy business segment that could be considered as ITS. We follow the loose definition of ITS given by the Intelligent Transportation Society of America [11]:

“ITS is the collective term for the use of electronics, communications, and information processing technology to improve all aspects of transportation—including public transportation.”

The choice how to define an industry and how to aggregate (or disaggregate) industry data is always subjective and done on a pragmatic and/or *ad hoc* basis. For example, the industry definitions of Statistics Finland and Eurostat vary from time to time, depending on the purpose of use and usability. What is relevant is the continuation of uninterrupted time series if one wants to see how industries and company clusters are developing over time. Hence, our decision on aggregation of company data is purely a pragmatic choice, which may be rightfully criticised, but which provides uniform time series and hence best foundation for conclusions and prospective policy decisions.

3. Methods and Data

The methodological foundation lies in microeconomics basic concepts and tools. The paper relies on empirical data and applies the standard metrics of market and industry structure analysis. The merit of the paper is in its empirical material and its handling. This is the very first ITS quantitative, empirical supply side market analysis that has been carried out in Finland and published for wider audience. Based on our review of literature in the field, we claim that it is one of the few public analyses in the world.

The first set of companies were selected by our own organization’s (VTT) business intelligence unit whenever it was found from public documents or text media (press, internet) that “intelligent transport systems” was associated with the company in question. The sample was reduced when the internet sites and annual statements of the companies were individually studied and if the ITS aspect was found to be relevant enough, *i.e.* the company obviously delivered ITS products and/or services to its customers, the company was included in the sample. If there was still uncertainty whether the company entitles an “ITS” label the company was contacted directly and senior management was asked if the company had any

ITS-related business.

Some of the companies could be explicitly regarded as “100% ITS focused” meaning that all its business was about ITS product and/or service delivery. For multi-segment companies there were several methods to assess the volume of ITS-related business: 1) the ITS related business segments were reported in terms of volume in the company’s annual statement reports; 2) ITS-related business volume was also gathered from public databases providing company’s financial statements; 3) a direct question was placed to the senior managers of the company in question asking how big a share of their business was about ITS; 4) if none of the abovementioned methods were working, the authors made their own assessment based mainly on number of identifiable business segments and headcounts. For the last case, for example, if the company reported five main business segments of which ITS or transportation was one and if this segment seemed to include 10% of the work force, the obvious conclusion was that the ITS business volume as a percentage of turnover was likely to be somewhere between 10% and 20%. In some individual cases the assessment was on an unstable foundation which affects mainly the market size estimate. A brief sensitivity analysis was performed to tackle the most obvious uncertainties.

The turnover figures were picked from annual statements which were available from several sources as well. The first was the companies’ web sites. If the sites did not present annual statements, the public databases that collect information from the National Board of Patents and Registers of Finland (www.prh.fi) were used. These data bases included free-of-charge services provided to analysts, such as Fonecta Finder (www.finder.fi) and Yritystele (www.yritystele.fi). Third source was economics and finance journals that provided corporate analyses for business and investor community, such as Kauppalehti (www.kauppalehti.fi). Many times the data was cross-checked using two or three sources for the same company but since the original data came from Patents and Registers there were no grave errors we could detect. In few cases we could detect different figures that deviated a few percent units from each other but we consider biases of this magnitude insignificant, especially when thinking of other much more probable sources of errors, such as the uncertain estimates on the shares of ITS business in multi-segment firms.

The market size was estimated from the turnover figures from year 2010. The growth trend was approximated based on data for 2006-2010. The data periods were used for other purposes like employment effects of the sector. For industry and market structure, the 2010 data is used. The concentration of the industry is done both visually and using modified Herfindahl indexes (see e.g. US Department of Justice and the Federal Trade Commission, [12]).

The nationality, or rather the origin country, of the companies was decided based on the location of headquarters. Those headquartered in Finland were regarded as Finnish companies although the ownership could be anywhere. The large corporations' national subsidiaries, such as Siemens Finland Ltd., were considered as non-Finnish, international companies. The same logic positioned e.g. Vaisala Ltd. as a Finnish company although the great majority of the company's activities are elsewhere, including the ownership. This division was made thinking of the industrial policy recommendations we decided to draft based on the results of the study.

4. Results

4.1. ITS Supply Industry Structure and Size

There are three important, simplistic roles in supplying ITS products and services. First, the role of equipment and hardware providers that supply infrastructure or vehicle associated physical components or personal devices. Second group consists of systems and applications providers who supply entire or sub-sets of ITS systems which combine and integrate the products and services of systems and applications providers, sometimes including the services of the last group of suppliers, the service suppliers. The last mentioned category of the supply side provides consultancy, design, installing, and operating ITS services. These supply function groups meet the demands coming from the public, corporate customers, and consumers. In efficient market, they all meet in a stage of equilibrium (Figure 1).

The categorization follows that of presented also Yu *et al.* [13], who considered five key categories for Chinese ICT industry: the equipment provider (EP), application provider (AP), service provider (SP), content provider (CP), and operator, which are attributed to as supply chain members within the ICT industry. As stated previously, the operator role was excluded first because of its intermediating role and secondly because there were no significant services

delivered by the operator group. Even if they had, the revenue estimation would have been extremely difficult. Content provider role is merged to systems and applications provider role in our analysis and we do not attempt to draw clear role boundaries between the supplier segments. In many cases, there were two, even three, roles present within one company and we selected the one that we considered to be the dominant one. Figure 2 and Table 1 summarize the categorization and their relationship of ITS industry that has been used in this study.

The ITS supplier group comprised altogether 72 companies, of which 72% were local (Finnish) companies. Some industry structure metrics are shown in Figure 3. Service providers (SP) have a relatively dominant position 47% of total number of companies and 56% market share of ITS supply in Finland measured as turnover in year 2010. Equipment and hardware providers (EP) were the second largest group of companies measured by number of firms (30%) and with 33% market share. Systems and applications provider firms represented were more than fifth (23%) of the industry but yielded only to about 11% of the market.

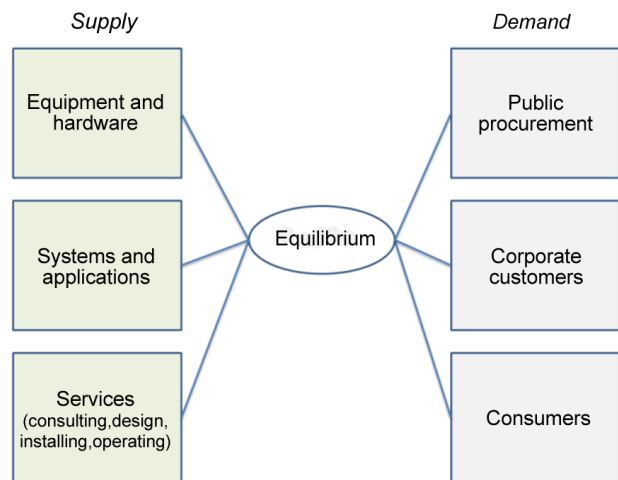

Figure 1. ITS industry structure—the supply and demand.

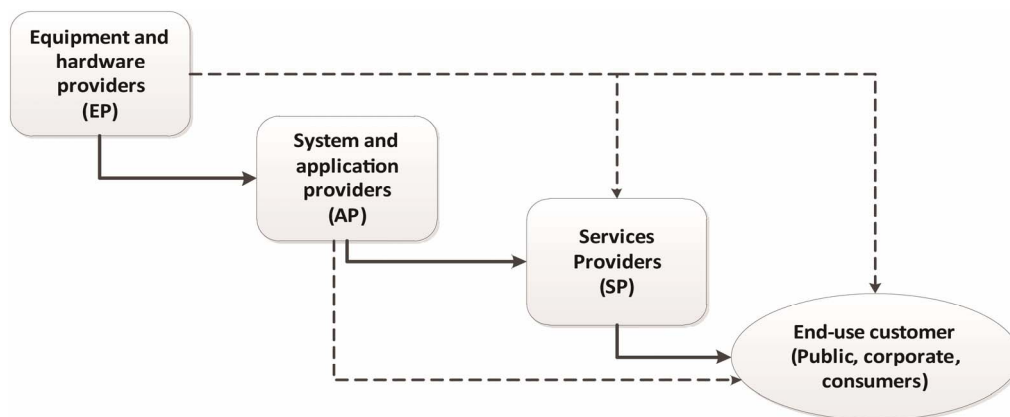

Figure 2. Simplified ITS industry supply chain.

Table 1. ITS industry categorization.

ITS supply roles	Description of activities (examples)
Equipment and hardware providers (EP)	<p>Manufacturing and/or distributing components and end-use ITS products (hardware) to the customer and ITS apps and service providers. These products include, for example:</p> <ul style="list-style-type: none"> • In-vehicle computers • Tracking and tracing devices • Sensor components and devices • Safety equipment • Metering equipment • Meteorological observation equipment
System and application providers (AP)	<p>Producing several ITS-supported systems, contents, applications and software, such as:</p> <ul style="list-style-type: none"> • Mobile information systems and software, e.g. online card payment, intelligent positioning systems, and data collection systems • Automated dispatching and wireless data transfer applications; GPS and digital map based routing and location systems • Traffic management systems, command and control systems for transport, radio communication systems for transport, real time weather information management systems, etc. • Geographic Information System (GIS) combining maps and traffic information • Real time driver guidance system, tracking driving behaviour, etc.
Services providers (SP)	<p>Delivering ITS services/ solutions to customer, including consultancy, design, installation, and operating of ITS services. They are mainly producing contents, but not applications, software, and equipment related to ITS, which they sometimes however utilise them in delivering ITS services/solutions to the end customer.</p>

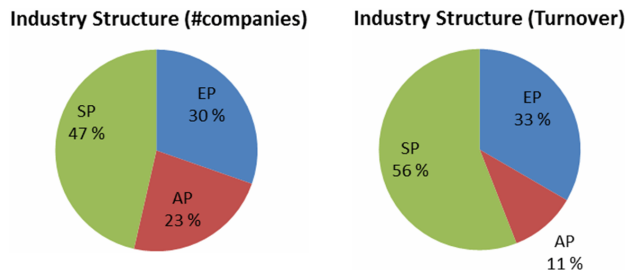

Figure 3. ITS Industry compositions.

The size of the market is simply approximated as the summed turnover of the companies. This sum represents the total value of ITS goods and services supplied. Based on cautious calculation of turnover data provided by trusted sources (as explained in chapter 3) of financial information, it can be roughly estimated that the total ITS market size in Finland valued around 300 million in 2010. This means a figure that is approximately 0.17% of total GDP in Finland in 2010.

In the categorisation of firm size, the Eurostat standard (The new SME definition user guide and model declaration [14]) was applied when dividing the companies into micro, small, medium-sized, and large companies:

- 1) Micro company: annual turnover less than 2 million €
- 2) Small company: turnover between 2 to 10 million €
- 3) Medium-sized company: turnover between 10 to 50 million €
- 4) Large company: more than 50 million €turnover.

It should be noted that the turnover value used is only the ITS business related turnover—not directly the company’s turnover itself as shown in its financial statement. Hence, a multi-national giant corporation can be a small-time ITS player in Finland. For some companies, the authors

estimated the share of the turnover by themselves based on analyst reports, annual reports and website information given by the company. These companies were, however, a clear minority. **Figure 4** shows the industry structure in terms of firm sizes.

It is observable that medium-sized and small companies dominate in the market, or at least, the big players do not have a dominating position. The medium sized-companies reached in sum a turnover of around €140 million, followed by small companies with a turnover of about €80 million in 2010. However, a closer examination revealed that there is a restricted group of medium-sized companies (5 companies) and one large company that hold a significant share of the ITS market. We did not however, analyse how dominant these positions were and how they showed in different groups (EP, AP, SP). This would certainly be a case for further analysis.

ITS market concentration was also evaluated by using a modified Herfindahl index. It is calculated by summing of square of the individual firms’ market shares. Equation (1) is the formula for calculating the Herfindahl index.

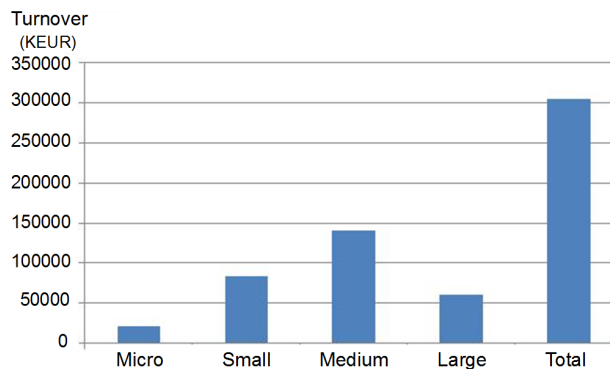

Figure 4. ITS supply market size and firm sizes.

$$H = \sum_{i=1}^N s_i^2 \tag{1}$$

where s_i is the market share of firm i in the market, and N is the total number of firms in the sample.

The Herfindahl index of ITS industry in Finland in 2010 was 0.092. The text book interpretation is that the market is *unconcentrated* (below 0.15) and no monopolistic or even oligopolistic features can be witnessed at first sight. This is followed with an obvious notation that the market seems to be fairly competitive. Although the moderate concentration do exist within the same segment of the industry value chain, especially for AP and SP. Otherwise, EP seems to have a high concentration indeed, because of a large EP company has contributed a significant market among others. Furthermore, **Table 2** presents descriptive information regarding to ITS market concentration from other approach.

The employment numbers of ITS industry was also checked. The Finnish ITS supply market had around 1700 employees in 2010. **Figure 5** shows the scatter diagram of number of employees compared to the turnover of each company. Only a handful of companies employ more than 100 employees and the firm sizes look very modest from this perspective. Again, the share of ITS business related turnover was used as a proxy for ITS related employees.

It goes without saying that the whole ITS market, if the demand side is calculated in, will be somewhat bigger in terms of employment. The authors doubt, though, that the employment factor is not one-to-one but much smaller than that. The number of people working in the field of ITS in government sector is read in dozens, not in hundreds.

4.2. ITS Market Growth and Other Characteristics

ITS market growth in Finland was also examined. As

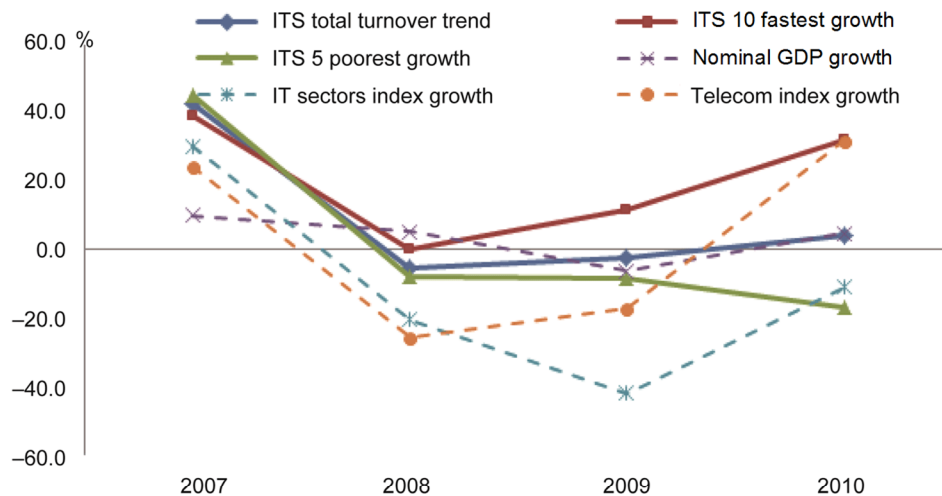

Figure 6. ITS market growth and economic growth.

stated earlier, the market growth was calculated using only those companies that were considered as 100% focused on ITS business. Altogether, 24 such companies (one third of total number of analysed companies) were included in growth analysis. The annual growth was taken from annual turnover changes for 2006-2010. Ten on average fastest grown and five weakest grown companies were analysed separately to capture the dispersion between fast and slow growing entities. Furthermore, the growth figures were compared to general economic growth, namely annual changes in GDP (provided by OECD [15]). Nominal values were used for growth calculation, meaning that the face values of each year turnover were used as such with no inflation or any other value of time adjustment. Using nominal values throughout the line makes the figures comparable. (If inflation adjustments would have been used, also GDP growth would have needed to be stated in real terms). **Figure 6** shows the trend comparison graph.

Table 2. ITS market concentration.

ITS companies	% industry turnover	% number of employee	ITS supply role
2 largest	32.56%	35.36%	1 EP and 1 SP
5 largest	60.90%	57.73%	1 EP and 4 SP
10 largest	75.25%	69.61%	3 EP, 5 SP and 2 AP

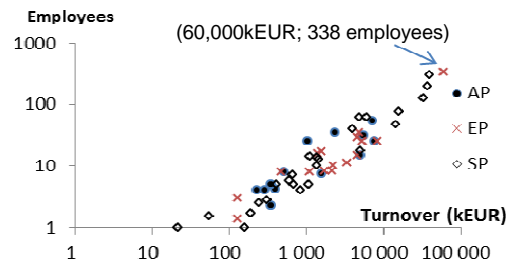

Figure 5. Number of employees-turnover scattered diagram.

From the graph it is visible that ITS market had a significant growth in 2007 but has since then been very slowly turning upwards from the negative growth observed in 2008 and 2009. However, the growth of the market based on firm sample is yet promising when compared to GDP growth. The fast growing firms have clearly been doing well whereas the weakest performers seem to have a continuous declining trend.

Besides comparing ITS market growth with GDP growth, also other benchmarking indicators were looked at. The Finnish Share Indices for Information Technology sector index, and Telecommunication Services sector index, provided by Bank of Finland [16]. **Table 3** shows those indices.

Since ITS by definition is expected to have a strong correlation with IT and telecommunication services, it is interesting to witness what has happened in the eyes of the investors during the same time period. The IT sector share prices have declined as investors have moved to other sectors, whereas the telecomm services sector has been gaining IT and surpassed it in terms of growth. Much of this is due to Nokia's dive which is doubtlessly visible in the IT sector index curve. Nokia weighs still quite much in the Finnish stock market list although the relative share of the composite indices has reduced during recent years. ITS companies' turnover has followed quite closely to GDP figures. This is a fact to recognise and we will take this up later.

What was left out from this analysis (and saved for later) was the correlation analysis between the returns of ITS companies and share indices. With this information, the industry beta (see e.g. Leviäkangas [17] for detailed beta calculation methods and Nokkala *et al.* [18] for sectoral betas) could be derived describing how systematic was the risk of ITS industry.

5. Evaluation and Discussion-Reliability and Validity

To evaluate the reliability of the results the most significant sources of possible bias comes from the authors' own estimates concerning the ITS business segment size of the supplying side of the industry. 18 out of 72 companies were assessed by the authors with only very limited amount of financial information. For 12 companies out of 72 the size of ITS business segment was deemed to be almost zero because these companies did not have too many significant extent identifiable services or products related to ITS. Still, these companies were active in the

Table 3. Finnish share indices.

Finnish Share Indices	2006	2007	2008	2009	2010
Information Technology	30	39	31	18	16
Telecomm. Services	25	31	23	19	25

field and e.g. participating the activities organised by ITS Finland, the national ITS lobby group (www.its-finland.fi). These activities were considered to be actions of business development rather than actually having direct association with existing business offering, not to mention revenues. For three (3) companies we managed not to make any kind of assessment so they are certainly a possible source of bias. However, out these three, only one was considered to have a significant amount of ITS business as it was defined in this paper. This could impact influence the results with less than one percent unit.

The second source of bias which we must consider is the actual definition of what is regarded as ITS. However, this is a systematic error and is contingent, that is depending on the dimensions and contents of definition of ITS. For all the market studies used as a reference and starting point of this research this source of error is more than obvious. Hence the conclusion is that this paper delivers so far the most reliable supply market estimate for Finland where the sources of errors have been acknowledged. The estimate of ITS contributing to approximately 0.17% of GDP is considered to be of correct magnitude. It is certainly serving well enough the industrial policy making if such policies are considered with regard to ITS. To compare this result, although the methods are not most likely coherent, Ezell [1] reported that South Korea and Japan invested some 0.016% of their GDP in ITS, whereas US did 0.008%.

As to growth estimates, the only companies included to the sample were those that were assessed as 100% ITS companies. As the fastest growing and the weakest growing ranges were analysed the spectrum should be visible enough. It is clear that ITS industry as such is not a growing or fast growth business. Some companies are just the promising ones and some not so much so. This is an important finding, although looking quite self-evident. What seems to be quite visible is that ITS is still as an industry growing faster than the total economy during the last few years. This is an equally important notification. Exclusion or inclusion of the few missing companies with their data is not likely to change this picture at all. However, the authors suggest that a more realistic picture concerning ITS should be taken and too high expectations should be avoided.

For next steps to continue this research the following is proposed: 1) splitting the supply side of the industry into more detailed value chains and considering what the growth potential could be in different parts of chain; 2) analysis on changes in the industry structure over time—are the big players getting an ever bigger slice of the market or vice versa? Is service providers' role getting any different or is it the hardware providers than then dominate the market? 3) how is the employment changing over time and what is the labour productivity devel-

oping? This follows somewhat also to other structural changes of the industry: services usually always employ more people than manufacturing; 4) further analysis of the prospective role of telecom operators as service providers. If they are successful in building financially viable consumer or B2B services, this could have a radical impact on the market size. On the other hand, equipment manufacturers, especially mobile personal devices manufacturers are already today trying to package various type of services package in their products. This would imply that the services market is somewhat the follower of the equipment market.

6. Implications to Industrial Policy, Investments and Business Strategies

Since the analysis is about one country's one industry segment, the findings and their implications inevitably must touch the national industry policies and how policy makers should view the industry as a prospective source of economic growth and employment. Below we reflect our own conclusions which were formed during the undertaking of this research.

Our first concern regarding the ITS industry was the sluggish growth of ITS focused companies. As we looked closely at that group, we noticed that many of those could be regarded as consultancies. Consultancy in Finland is traditionally offered more to the public sector due to public sector's strong role also in the ITS development. There is even a national ITS strategy issued by the Ministry of Transport and Communications Finland [19] which states as one its goals to have a strong ITS domestic industry.

Another point that caught our eye was the close relationship between GDP and 100% ITS firms' turnover development. There is a risk that much of the ITS service segment, which is the dominant segment, is associated with consultancy to the public sector. From industrial policy point of view this is not a good signal thinking of the building of the industrial basis for the country, not at least from ITS building blocks. Hence our analysis provides a weak warning signal concerning the long-term effects and employment capacity of the domestic ITS industry. This signal is strengthened by the fact that there are few real services out in the market, delivering the benefits expected from ITS.

Third, the *servitization* of industries, even the high-tech ones, is enhancing the roles of traditional equipment and hardware providers. There are a number of reasons why this is happening, but the end result is that equipment manufacturers are integrating themselves vertically and downstream along the value chain [20-22]. A growing number of consumers are not buying a Samsung or Nokia phone, but the services these manufacturers have been able to package with the phones. There is no doubt

that in the ITS industry this about to happen as well. Unless there is a strong equipment and hardware manufacturing base in the country, there will be less chances to create a domestic service sector along with manufacturing. In Finland's case, this means the invasion of international conglomerates which will try to capture not only the equipment segment, but also a big chunk of the services. We see a weak signal also here, but acknowledge that such development is good for the companies and most likely for the end users. For political system, that is always looking at the world through lenses with "our flag's colours" the development can be undesirable.

Dedicated application and service providers should have very competitive concepts to compete against horizontal integrators, particularly if the same integrators' components or equipment must be used in applications and services. On the other hand, service business has so far been mostly local (overlooking the ownership issues), but even this logic seems to be changing. Public transport services, security services, not to mention more ICT-intensive services, such as travel agency services, have become global businesses within a decade or so... and the actual list is very long. Even the employment impact can be locally insignificant.

Investors are naturally aware of the above signals and act accordingly. New start-ups will have it difficult to find capital investors unless they have something very unique to present which will survive the competition, first domestically and then internationally, or which are technologically so superior that competitors are forced either to ally with start-ups or buy them out. Services and applications can be lucrative investment objects only if the concepts are strong enough for international scope. Domestic concepts can be innovative and locally providing jobs, but for most part they can probably be copied and transferred to other markets with reasonable effort and tailoring. Investors do not really care whether the business then expands or is sold to a formidable bidder just as long as the returns are there.

To return to the question on industrial policy, we may ask the question how to build up an industry? Should we start from manufacturing and then move on to services? We claim that this is the more natural evolution path to take and a number of equipment manufacturer stories exist where they have successfully moved to cover also services. The opposite is harder to distinguish. This leads to the conclusion, that if a country wants to build a successful new industry, it would need to find a solid and tangible base for it, the companies that deliver hardware and equipment. However, there is an opposite trend in the industrial policy and public financing of technology and innovations. This thinking leans on business prospects and providing something straight to the markets, "time-to-market" is the magic word. We claim that this

thinking is not without risks, particularly so if it lacks the industrial cornerstones. It may lead to innovation investments that are close to the market and end-user oriented, but lack the necessary building blocks for even a foetus of an industry.

ITS is already in its prime youth, though, but the trick for smaller players is to make exactly the right bets, because they cannot afford to lose their money in small-time efforts which do not foster real long-time growth.

7. Acknowledgements

Financial support from VTT (Graduate School and INT-RANS Innovation Programme) and Ministry of Transport and Communications Finland are acknowledged.

REFERENCES

- [1] S. Ezell, "Explaining International IT Application Leadership: Intelligent Transportation Systems," ITIF Publication, Washington DC, 2010.
- [2] J. N. P. Kristensen, "Why ITS Needs PCP," P3ITS Webinar, ERTICO, 26 May 2011.
- [3] F. Ferreira, "ITS Action Plan and Directive—Framework for the Deployment of Intelligent Transport Systems," P3ITS Workshop, ERTICO, 2010.
- [4] P. Leviäkangas and A.-M. Hietajärvi, "Weather Information for Transport—The Value Shift," *Value World*, Vol. 33, No. 2, 2010, pp. 4-13.
- [5] P. Leviäkangas, "Building Value in ITS Services by Analysing Information Service Supply Chains and Value Attributes," *International Journal of Intelligent Transport Systems Research*, Vol. 9, No. 2, 2011, pp. 47-54.
- [6] BCC Research, "2010 Intelligent Transport Systems Review," 2010.
<http://www.bccresearch.com/report/2010-intelligent-transportation-systems-trn001d.html>
- [7] S. Dutta and I. Mia, Eds., "The Global Information Technology Report 2009-2010," World Economic Forum, Cologny, 2010.
- [8] M. E. Porter, "Competitive Advantage: Creating and Sustaining Superior Performance," Free Press, New York, 1985.
- [9] B. C. Eaton, D. F. Eaton and D. W. Allen, "Microeconomics," 5th Edition, Prentice Hall, Toronto, 2002.
- [10] R. S. Pindyck and D. L. Rubinfeld, "Microeconomics," 7th Edition, Prentice Hall, Toronto, 2008.
- [11] Intelligent Transportation Society of America, "Sizing the US and North American Intelligent Transportation Systems Market: Market Data Analysis of ITS Revenues and Employment," 2011.
- [12] US Department of Justice and the Federal Trade Commission, "Horizontal Merger Guidelines," Washington DC, 2010.
- [13] L. Yu, *et al.*, "Chinese ICT Industry from Supply Chain Perspective—A Case Study of the Major Chinese ITS Players," *International Journal of Production Economics*, Vol. 115, No. 2, 2008, pp. 374-387.
[doi:10.1016/j.ijpe.2008.03.011](https://doi.org/10.1016/j.ijpe.2008.03.011)
- [14] European Commission, "The New SME Definition—User Guide and Model Declaration," Commission Recommendation 2003/361/EC, *Official Journal of the European Union L*, Vol. 124, 2003, p. 36.
- [15] OECD, "Country Statistical Profile: Finland 2011-2012," 2011.
- [16] Bank of Finland, "Finnish Share Indices," 2012.
http://www.suomenpankki.fi/en/tilastot/arvopaperitilastot/Pages/tilastot_arvopaperimarkkinat_osakkeet_toimialaind eksit_en.aspx
- [17] P. Leviäkangas, "Private Finance of Transport Infrastructure Projects—Value and Risk Analysis of a Finnish Shadow Toll Road Project," VTT Publications, Espoo, 2007.
- [18] M. Nökkälä, K. Finnilä, J. Rönty and P. Leviäkangas, "Financial Performance of Finnish Technical Networks," *VTT Working Papers* 163, 2011.
- [19] Ministry of Transport and Communications Finland, "Intelligent Transport Systems and Services: Finnish Strategy," Libris, Helsinki, 2005.
- [20] T. S. Baines, H. W. Lightfoot, O. Benedettini and J. M. Kay, "The Servitization of Manufacturing: A Review of Literature and Reflection on Future Challenges," *Journal of Manufacturing Technology Management*, Vol. 20, No. 5, 2009, pp. 547-567. [doi:10.1108/17410380910960984](https://doi.org/10.1108/17410380910960984)
- [21] T. Baines, H. Lightfoot, J. Peppard, M. Johnson, A. Tiwari, E. Shehab and M. Swink, "Towards an Operations Strategy for Product-Centric Servitization," *International Journal of Operations & Production Management*, Vol. 29, No. 5, 2009, pp. 494-519.
[doi:10.1108/01443570910953603](https://doi.org/10.1108/01443570910953603)
- [22] A. Neely, "Exploring the Financial Consequences of the Servitization of Manufacturing," *Operations Management Research*, Vol. 1, No. 2, 2008, pp. 103-118.
[doi:10.1007/s12063-009-0015-5](https://doi.org/10.1007/s12063-009-0015-5)

Appendix

List of analysed companies with financial information directly and/or from financial statements: Aplicom Oy, Corenet Oy, EC-Tools Oy, Elektrobit Oyj, Fara Oy, Havainne Oy, Idesco Oy, Indagon Oy, Infotripila Oy, Mattersoft Oy, Max Technologies Oy, Mediamobile Nordic Oy, Mitron Oy, Mobisoft Oy, Navielektro Ky, Peek Traffic Finland Oy, Sabik Ab Oy, Semel Oy, Sunit Oy, Suomen Fartskriver Oy, Swarco Finland Oy, Taipale Telematics Oy, Tietomekka Oy, Traficon Oy, Oy Mat-

kahuolto Ab, Payway Oy, Aspicore Oy, Foreca Oy, Fifth Element Oy, Emtele Oy, Ebsolut Oy, Logica Suomi Oy, Trafix Oy, Tramigo Oy, Procomp Solutions Oy, Proactum Oy, Noptel Oy, Labkotec Oy, ESRI Finland Oy, Sarco Oy, Teconer Oy, YSP Oy, Pocum Oy, Strafica Oy, VTI Technologies Oy, Destia Oy, Sesam House Oy, Siemens Oy, Ramboll Finland Oy, Digia Finland Oy, Enfo Oyj, IBM Ab Oy, Vaisala Oyj, Jaakko Pöyry, Tieto Oyj, Navteq BV Finland.

ARTICLE III

The Finnish road weather business ecosystem – turning societal benefits into business and the other way round

Engineering Management Research 3(1): 56–67.
Copyright 2014 Authors.

The Finnish Road Weather Business Ecosystem - Turning Societal Benefits into Business and the Other Way Round

Pekka Leviäkangas¹, Aki Aapaoja¹, Tuomo Kinnunen¹, Eetu Pilli-Sihvola², Raine Hautala² & Zulkarnain²

¹ Industrial Engineering and Management, University of Oulu, Oulu, Finland

² VTT Technical Research Centre of Finland, Espoo, Finland

Correspondence: Zulkarnain, VTT Technical Research Centre of Finland, Kaitoväylä 1, P.O. Box 1100, FI-90571 Oulu, Finland. Tel: 358-20-722-2018. E-mail: zulkarnain@vtt.fi

Received: January 30, 2014 Accepted: February 25, 2014 Online Published: March 19, 2014

doi:10.5539/emr.v3n1p56

URL: <http://dx.doi.org/10.5539/emr.v3n1p56>

Abstract

This paper investigates the winter road maintenance ecosystem in Finland and discusses its importance in ensuring mobility. The ecosystem model is illustrated using the Customer Value Chain Analysis (CVCA) tool and is constructed based on publicly available material and direct information from stakeholders. The model describes the roles and functions of stakeholders and their value network. With the help of the model, further analysis based on value analysis and value theory is conducted to evaluate the current ecosystem. The service and product offerings of individual stakeholders are isolated and described in more detail. The main idea is to show how individual offerings can supplement each other in the process of value co-creation. To enhance and co-create value, collaborative development of the ecosystem is perceived as the best value capturing strategy.

Keywords: road maintenance, winter, ecosystem, value co-creation, value analysis

1. Introduction and Aims

Our mobility system serves multiple critical functions of our society. The moving of people and goods needs to be ensured not only in everyday circumstances but also in harsher and more exceptional conditions. Weather and infrastructure availability go hand in hand; different weather phenomena affect the transport environment and infrastructure in terms of safety, reliability and accessibility. Recent research findings show that the impacts of weather are quite significant (see e.g. Leviäkangas et al., 2013; Molarius et al., 2013). In the Northern Hemisphere, winter poses radical challenges to mobility and transport.

In winter, surface land transport infrastructures including roads and railways must be kept in usable condition. Snow must be removed and ice melted or treated, and road users, travellers and transport operators must be made aware of the condition and availability of their route and modal choices. Maintenance service providers carry out these operations at the request of infrastructure owners, which usually are national or local road authorities and railway companies or agencies.

Over the past two or three decades, public sector infrastructure managers have unbundled their functions, with a widening specter of services related to maintenance and construction of transport infrastructures being outsourced to the private sector, while ownership of the infrastructure and ultimate responsibility for it has remained with the public sector (Leviäkangas et al., 2011). Hence a capable and resourceful service provider network has become an increasingly vital resource for communities and societies in ensuring that basic functions, such as mobility, perform seamlessly and efficiently.

Here we discuss the importance of such a service and technology provider network, which we regard as an ecosystem, in the ensuring of mobility. We focus on winter maintenance of the road network and show how this ecosystem is built in Finland to provide safety, reliability and accessibility of roads, first to infrastructure managers/owners and ultimately – and in particular – to road users. We further discuss and argue that such ecosystems that form a part of critical societal functions are one of the competitiveness parameters of any community, society or country. Unless these ecosystems are made to work effectively, the functions of society will underperform and efficiency losses will materialize.

The purpose of this paper is to model the Finnish road weather ecosystem using systems and value engineering tools in describing the roles of different stakeholders within the ecosystem. Finally, we present some conclusions

on the examination of the ecosystem.

2. Method and Process of Analysis

To understand the current state of the Finnish winter road maintenance business ecosystem, our study applies the approach of systems theory. An ecosystem is, after all, clearly and by definition a system comprising multiple actors having inter-relationships between each other and the environment. Business ecosystems are characterized by a large number of loosely interconnected participants who depend on each other for their mutual effectiveness and survival (Peltoniemi, 2006). System thinking is a framework for problem solving that considers problems in a holistic manner and attempts to enhance the understanding of, and responsiveness to, the problem (Rubenstein-Montano et al., 2001). Outcomes from systems thinking depend heavily on how a system is defined, because system thinking examines relationships between the various parts of the system. Boundaries must be set to distinguish what parts of the world are contained inside the system and what parts are considered the environment of the system (e.g. internal and external stakeholders). The environment of the system will influence problem solving because it influences the system, but it is not part of the system (Rubenstein-Montano et al., 2001). Hence, business ecosystems are considered as systems with economic, social and technological aspects. Different tools can be used to present complex systems: diagrams, flow charts, morphological boxes, etc. (see e.g. Ritchey, 2002; Yourdon, 2012)

The ecosystem model is illustrated using Customer Value Chain Analysis (CVCA), which “is an original methodological tool that enables design teams in the product definition phase to comprehensively identify pertinent stakeholders, their relationships with each other, and their role in the product’s life cycle.” (Donaldson et al., 2006) The tool has mainly been used in the context of product development, where it extends the functionality and utility of the customer supply chain by requiring designers to study the value relationships, or value propositions, between the various participants (Donaldson et al., 2006). This study applies CVCA to the road weather ecosystem, and in our analysis, CVCA is used to first to draw the model of the ecosystem itself; secondly to evaluate and analyze the current ecosystem and to isolate the service and product offerings of individual stakeholders. The main idea is to show how individual offerings can supplement each other in the process of value co-creation.

The description of the winter maintenance ecosystem model is based partly on publicly available material (annual reports of companies, other reports and printed materials), but also largely on direct information from stakeholders. The analysis is part of the FIRWE (Finnish Road Weather Excellence) research project funded by the Finnish Technology Agency. The process of creating and validating the ecosystem model comprised a series of meetings and workshops held as part of the research in 2012–2013. The drafting was done by the researchers based on publicly available material, and the validation was performed in two workshops (3-4 hours each) attended by four ecosystem members (maintenance equipment manufacturer; vehicle location, measurement and tracking solutions provider; meteorological device manufacturer; and road weather and conditions forecast provider).

The background and theoretical foundations were laid on the basis of literature studies and deskwork. The ecosystem analysis is further based on value analysis and value theory. The attempt is to show that the functions performed by the ecosystem increase the value of the output, and that the value is greater than the sum of the functions as individual activities by individual actors (referred to here as stakeholders). In plain words, the ecosystem can provide value (benefits) to the customers of winter road maintenance, based on the supplementary skills and activities of service suppliers that build the supply side of the ecosystem.

Value is defined by the Society of American Value Engineers (SAVE International, 2007) as follows:

$$Value \approx \frac{Function}{Resources} \quad (1)$$

Value is formed when the desired functions are performed or delivered using resources in terms of money, time, materials, etc. When this principle is applied to service supply chains, i.e. value networks that deliver service rather than individual functions, we can state (see Leviäkangas & Hietajärvi, 2010) the following:

$$Value\ of\ service \approx \frac{Function1}{Resources1} + \frac{Function2}{Resources2} + \frac{Function3}{Resources3} = \frac{Service}{Resources\ 1 + 2 + 3} \quad (2)$$

In essence, the above conceptual value model (where functions and resources can run up to n in order to build the service aspired to) describes the philosophy of ecosystems providing services that have value to the users by

combining their resources and functions. Resources must be understood not only as costs of delivering a function but also as technologies, capabilities, distribution networks, market presence, and so forth. The list can be whatever the particular context may define as a resource. For example, in an ecosystem a small company offering unique technology may enable a service that would not be possible without it; or for some ecosystems a customer base managed by one company will enable the ecosystem to widen its customer base and increase sales revenues for all stakeholders within the ecosystem.

As we proceed with our analysis, the principles of value and value chain analytics principles become evident. We distinguish between the different functions (service and product offerings) of the ecosystem stakeholders in a value network and discuss the end-user value, which in fact becomes a socio-economic benefit that justifies performing the functions in the ecosystem. We also discuss the challenge of transforming this socio-economic benefit into tangible cash flows expected by the supply side of the ecosystem.

Depending on how we define the ecosystem, we can either have the supply side, i.e. the pure business ecosystem comprising companies with their offerings, or we can have the entire ecosystem with both the supply and demand side. We adopt the latter approach, with the resulting considerations between the dynamics of the two sides.

3. How Ecosystems Are Building a Competitive Advantage

3.1 Business Ecosystems

A business ecosystem is an economic community supported by a foundation of interacting organizations and participants. In ecosystems, participants can co-evolve capabilities around new innovations by collaborating to support new offerings, satisfy customer needs and eventually discover innovations (Moore, 1993). Iansiti and Levien (2004b) have described business ecosystems as “loose networks – of suppliers, distributors, outsourcing firms, makers of related products or services, technology providers, and a host of other organizations – that affect and are affected by the creation and delivery of a company’s own offerings.” In other words, ecosystems include a large number of loosely interconnected participants who depend on each other for their mutual effectiveness and survival (Iansiti & Levien, 2004a). In this study, the participants of ecosystems are called stakeholders. A stakeholder is any organization in the ecosystem that can affect or is affected by the achievement of the ecosystem’s objectives (Freeman, 1984). Typically the stakeholders are further divided into internal and external. Internal stakeholders are direct members of the ecosystems and hence have a clear role in them. External stakeholders are not formal members of the ecosystem, but may have an impact or are impacted by the ecosystem (Winch & Bonke, 2004; Cleland, 1986).

3.2 From Value Creation towards Value Co-creation

The ultimate purpose for a buyer and seller engaging in a relationship is to work together in a way that creates value for them. Walter et al. (2001) have defined value “as the perceived trade-off between multiple benefits and sacrifices gained through a customer relationship by key decision makers in the supplier’s organization. Those benefits and sacrifices can result from the relationship under question as well as from connected relationships on which the focal relationship has an impact or is impacted by those other relationships.”

Value creation should always be a win-win situation and the supplier needs to offer value to the customer but also needs to gain benefits from the customer (Walter et al., 2001). Therefore, in the current value chains, stakeholders no longer solely create value and thus wish to insert themselves into the chain and open up the possibility of contributing to value creation with their own activities. Ramaswamy and Gouillart (2010) have called this situation value co-creation. It is about redefining the process and methods, and redefining how organizations involve stakeholders by bringing them into the value stream and value creation process and involving them in it. Basically, value co-creation adds to project stakeholder collaboration and at the same time shifts the mindset from a traditional “subsystem delivery” to “system ensemble and experience co-creation.”

Another view of value co-creation is the dual division between supply and demand. Typically business ecosystems combine their offerings in order to better meet customers’ expectations and aspirations. Likewise, the lowering of the threshold between customers and suppliers can lead to closer co-operation between the demand and supply sides, where mutual benefits can be realized - suppliers having a better understanding of their customers’ needs and customers gaining better service and enhanced value for their money. The demand-supply divide follows the division between the public and private sectors (see Figure 1) and the most effective positioning of the divide has been under very active debate during the last two to three decades in the context of new public management (see e.g. Gruening, 2001). One of the embodiments of co-creation between the public and private sectors is public-private partnerships (PPP). Also PPPs have been studied to a vast extent in all

sectors of societal functions, but perhaps mostly within the transport sector, which makes it a noteworthy concept with regard to winter road management as well, albeit the fact that PPPs are mainly encountered as applications to procure and finance capital projects (see e.g. Leviäkangas & Ojala, 2010).

The trend of moving from value creation towards value co-creation perfectly matches the idea of developing the business ecosystem of Finnish road winter maintenance. At the moment, the value creation processes of both firms and stakeholders are mainly focused on their own products and services. Hence the synergistic benefits and values that could be co-created by working together in an ecosystem have not yet been defined, and there are no systematic ways of managing the ecosystem. However, the stakeholders in the Finnish road winter maintenance ecosystem have shown an interest in starting to develop the current value chain and their offerings towards a well-defined ecosystem, which identifies its capabilities and values in order to create efficient and safe “winter mobility markets”.

Value creation or co-creation itself comprises three compelling phases: value identification, value proposition and value delivery (Murman & Allen, 2002). In the first phase, the stakeholders and their values, needs and offerings are identified, followed by the value propositions that combine values, needs and offerings into collective purposes and objectives. Customer and external stakeholder perspectives of value are often understood more or less differently, and seeking a consensus is further complicated by the stakeholders’ (both internal and external) disparate revenue logic. Therefore careful consensus building and effective delivery processes are needed to merge the diverse needs and objectives. The complexity and disparate value perceptions are very common in service delivery value networks, and are typically encountered in information-intensive services as described by Leviäkangas (2011) and Herrala et al. (2009).

3.3 Ecosystem Dynamics

There is a deeper dynamics between ecosystem stakeholders, regardless of their positioning or role within the ecosystem. Weiller & Neely (2013) correctly identify that on the supply side of the ecosystem, the business models of individual companies partly depend on the ecosystem they are working in, but affect it at the same time. Hence the ecosystems are dynamic in terms of evolution phase (time) and content (composition and operating modes and business models of the members). Early stage ecosystems (usually smaller and consisting of smaller companies) change as the key stakeholders change their business models. Exit or entry of stakeholders likewise changes the logic, structure and operating and/or business models of remaining ecosystem members, unless there is a perfect substitute to fill the empty position or the entrant is merely replacing a leaving member.

The fewer vital key members there are in the ecosystem, the more vulnerable it becomes in terms of entry and exit of these particular members, as substitutes may be difficult to find or non-existent. On the other hand, the internal dynamics of the ecosystem becomes simpler and more straightforward when the number of members is limited. At the same time, yet, the interdependency between the members increases. Simplicity may also be a strength, especially in the early evolutionary phase of the ecosystem, or when the market size in which the ecosystem is operating is limited. The topological structures of ecosystems are probably of a wide variety, but state-of-the-art industry structure analysis tools can be used, for example when measuring the concentration of market power and size (see e.g. Zulkarnain & Leviäkangas, 2012 for an analysis of the intelligent transport systems industry in Finland).

4. Winter Maintenance Ecosystem

4.1 A Generic Model

The question of how winter maintenance services can be turned into societal benefits in a way that brings value both to the supply and demand sides of the ecosystem can be described as a traditional value chain. The offerings (i.e. functions) of supply side technology, component, system, service and value-added service providers are ‘packaged’ into services that are demanded by end users. Not only does the supply side comprise a value chain, but so does the demand side; road authorities acting on behalf of road users, for instance, may have certain functions that add to the value of end-user services. Public information on road conditions, management and control functions in maintenance operations are examples of such ‘services’ provided to road users.

The divide between supply and demand is not fixed. As policy changes in infrastructure management have increasingly shifted the responsibility, at least in operational terms, to the private sector, the dividing line has been shifting from left to right (see Figure 1), reducing the role of the public sector. Another change could be forced by technology, and is the case here where information and communications technology (ICT) has played a huge role in recent years. The ICT enabler has pressed the public sector into redefining its role in many functions, not only those concerning winter maintenance. While the sole enabling factor has been only one motivation, the

capability of the public sector to manage this change has probably been equally important. Where enablers are not mastered and there is not enough capability to govern the new situation, the obvious answer has been to shift part of the responsibility onto the private sector (Leviäkangas & Hietajärvi, 2010).

The obvious conclusion is that the ecosystems may be highly unstable if technology and policy changes are affecting the environment they operate in.

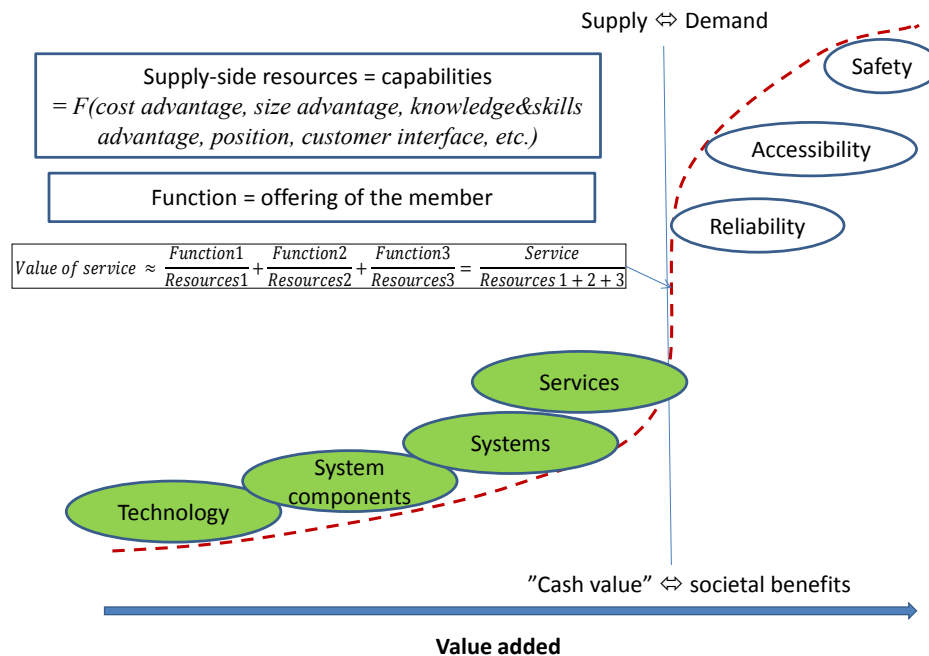

Figure 1. The ecosystem value creation process

4.2 The Current Finnish Winter Maintenance Ecosystem

The ecosystem of road maintenance in Finland is built around three types of roads: state-owned highways and other public roads, municipal streets, and private roads. All stakeholders represent some function connected to these three types of roads. The main purpose and objective of the ecosystem is to provide safe and fluent road conditions for traffic and end users, including private, commercial and other professional traffic.

Figure 2 illustrates the current perception of the Finnish winter road maintenance ecosystem and the value network. Additionally, Table 1 lists the stakeholders and their role and offerings in more detail.

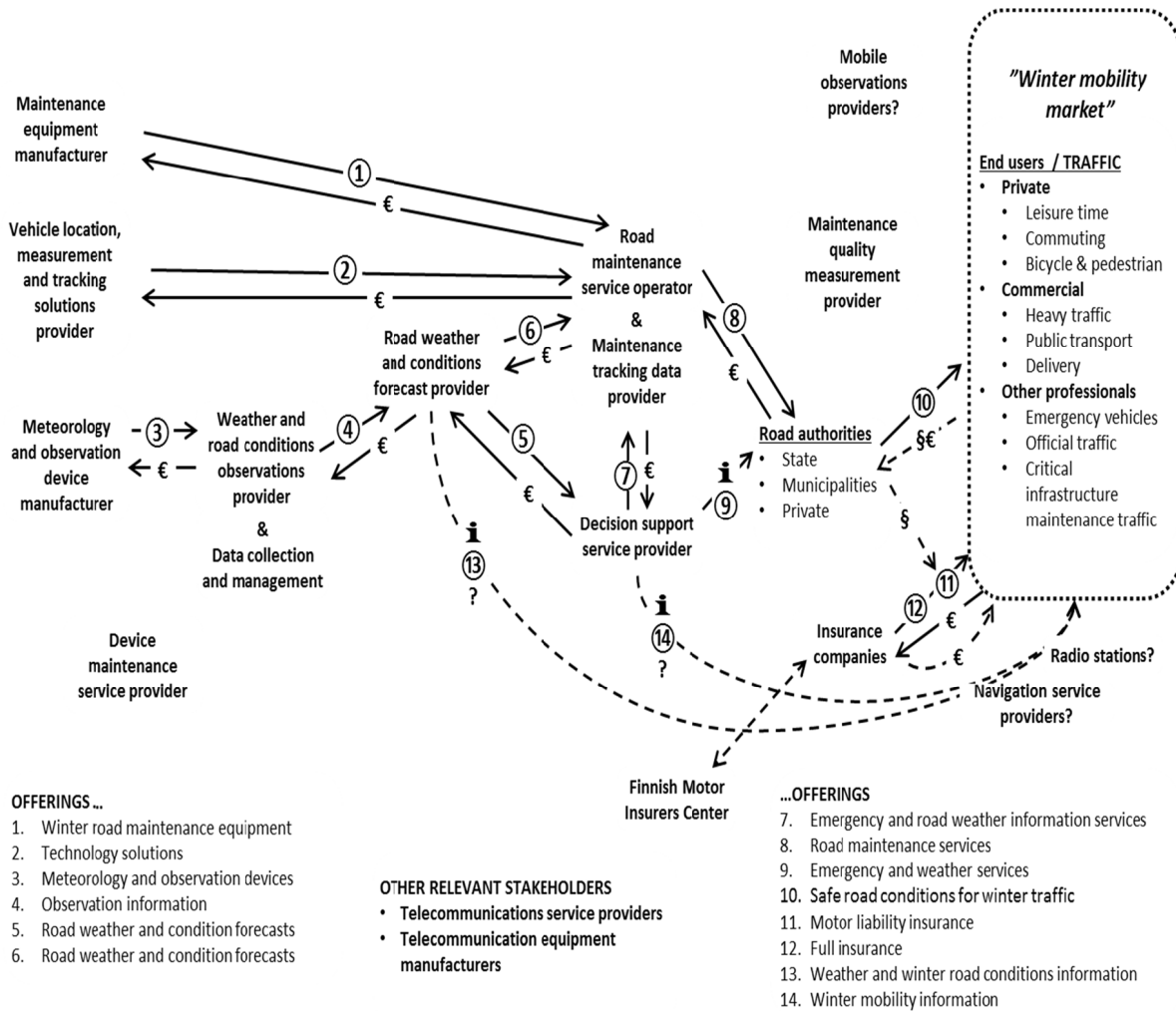

Figure 2. Value network of the Finnish winter maintenance ecosystem

As seen in Table 1, the ecosystem includes both internal and external stakeholders. Adapting Rubenstein-Montano et al. (2001), if development of the ecosystem and its value creation is desired, this will be accomplished in terms of internal stakeholders, because they are the direct and “formal” members of the ecosystem. External stakeholders that are able to change along with the ecosystem will probably benefit indirectly from its development. Thus this development may not necessarily have an explicit impact on their business or business models.

For example, telecommunications equipment manufacturers or telecommunications service providers are good examples of external stakeholders. Although the existing ecosystem is developed, it does not have more than a minor impact on them and their role remains the same. On the other hand, nowadays almost everything is connected and based on ICT technologies. Thus it can be argued that ICT products and services enable the building and development of the ecosystem as a whole and the communications system operators have an intermediating role in the value creation process (Leviäkangas, 2011)

Insurance companies do not directly benefit from the development of the ecosystem or winter road safety. However, safety improvements reduce accidents and reimbursement rates as well, which has a positive impact on the insurance companies’ business, at least in the shorter term.

Demand and supply side stakeholders are denoted by letters D and S respectively in Table 1. It should be noted that the table relates only to Finland; in other countries the roles, functions and responsibilities may be divided differently, as would obviously be the case concerning the division between supply and demand.

Table 1. Roles and functions of stakeholders of the Finnish ecosystem

Stakeholder	Role and function in the ecosystem	Type
Maintenance equipment manufacturer	Manufacture of road maintenance equipment that can be installed in road maintenance vehicles, for snow removal, anti-skid treatment and data logging depending on the functions of the devices.	Internal (S)
Vehicle location, measurement and tracking solutions provider	Provides systems and solutions for monitoring e.g. the location of the vehicle, route history, hours of operation.	Internal (S)
Meteorology and observation device manufacturer	Provides a comprehensive range of observation and measurement products (e.g. road weather stations, RWS) and services for chosen weather-related markets.	Internal (S)
Device maintenance service provider	Repair services include fault tracing and repair or replacement of failed RWS and components, and final testing to ensure that the equipment is functioning properly.	External
Road and weather conditions observations provider & Data collection management	Road and weather condition observations are collected and produced with public funds and are thus freely provided by the Finnish Meteorological Institute and the Finnish Transport Agency. Data management is also handled by the organizations.	Internal (S)
Road weather and conditions forecast provider	Offers a wide variety of weather services for commercial shipping, road maintenance and air traffic using different models, observations and meteorological expertise.	Internal (S, D)
Decision support system provider	The system collects and uses current and historical road weather and pavement information. Allows decision-makers to use a system that provides guidance as to what to do based on current and predicted weather.	Internal (S)
Decision support service provider (aka Road Weather/Management Center)	Monitors weather and road weather conditions. With the help of accurate and frequently updated weather forecasts, the right equipment can be sent off to clear the street of snow, ice and slush at the right time. Emergency requests can be transmitted directly to drivers or the customer's work supervisors as agreed. In addition, produces weather and road weather information that can be used over the Internet.	Internal (S, D)
Road maintenance service operator & Maintenance tracking data provider	Undertakes maintenance operations according to agreements with road authorities/infrastructure owners. Keywords in winter maintenance are the anticipation of road weather conditions, selection of the right measures and their correct timing. Anticipation prevents worsening of road weather conditions and reduces the need for preventive actions. Correct timing of tasks also improves the economic efficiency of operations.	Internal (S)
Road authority/owner	The main purpose is to keep roads usable every day and ensure that traffic can flow safely. The owners are responsible for maintaining roads plus adjoining structures, bus stops and road lighting. Nowadays the maintenance is usually outsourced.	Internal (D)
User of road and infrastructure	End users (private people, commercial and other professional users) are those who use the infrastructure and for whom it is maintained.	Internal (D)
Insurance company	Provides e.g. compulsory motor liability insurance for a vehicle used in traffic. Generally insurance premiums are directly related to safety statistics.	External
Finnish Motor Insurers Center	A cooperation body of Finnish motor insurers.	External
Telecommunications service provider	Provides telecommunications services for consumers and businesses.	External
Telecommunications equipment manufacturer	Offers network products that give the ability to connect (voice, data, images or video) and to share ideas and information anytime and anywhere.	External

4.3 Social Benefits of Winter Maintenance

Bläsche et al. (2011) identify snowfall, low temperatures and blizzards as the most significant extreme weather phenomena related to winter road transport. The main impacts of these conditions are longer travel times, an increased risk of accidents and reduced accessibility of the road network. Strong et al. (2010) have found that adverse weather conditions reduce traffic speed and increase the frequency of crashes while decreasing the number of fatal crashes.

Road weather solutions that collect, refine, and/or distribute information to road users and to maintenance actors can provide significant societal benefits by mitigating these impacts as identified by e.g. Pilli-Sihvola et al. (2012).

Fabre and Klose (1992) maintain that the estimation of costs and benefits of a road weather information system should take into account road maintenance activities, driving costs, and environmental, social and psychological effects. They see that the most important benefit of RWIS is the possibility of anticipating icy road surface conditions and eliminating accidents caused by slipperiness by responding to poor road conditions more quickly. Additional benefits can be gained from improved maintenance methods through more efficient distribution of work and personnel and reduced use of maintenance materials. Leviäkangas and Hietajärvi (2010) compiled a summary of road weather information services and RWIS benefits, which showed typically clear positive benefit-cost ratios.

However, aside from information benefits, the benefits of actual maintenance operations have been studied much less, although a few early studies can be found. A report by the Finnish National Road Administration (1993) assessed the benefits of the road weather information system taken into use in Finland in 1987–1992. Time savings from de-icing activities were estimated to be 23 minutes per activity on average. With an average accident cost of FIM 300 000 and presumed change in accident risk (between icy and dry conditions) of 5.8 accidents / 1 000 000 km, the annual benefits due to quicker maintenance operations in the Kymi road district were found to be as follows:

- Accident cost savings – FIM 4.2M (MEUR ~0.7; EUR 1 ≈ FIM 6)
- Time cost savings – FIM 0.3M (MEUR ~0.05)
- Vehicle cost savings – FIM 0.1 (MEUR ~0.002)

This adds up to total benefits of about FIM 4.6M (MEUR ~0.752) in 1993 currency. At that time, the Kymi district was responsible for approximately 7% of the main roads in Finland.

The report by the Finnish National Road Administration (1993) also describes a pilot in 1991–1992 in the southern region of the Turku district, where a centralized road weather center was tested. In the centralized road weather center concept, road conditions are remotely monitored at a single centralized location. In normal conditions, on-duty staff was not sent out on the roads. In more difficult conditions, regional on-duty staff was called in to monitor the conditions on the road. Estimates of the resulting savings in personnel costs ranged from FIM 0.5M to FIM 1.0M, but these results applied to the historical situation when the road authority was an integrated entity, i.e. taking care also of the operational snow removal, de-icing and other winter maintenance. By 1995, the road weather center model was in use nationally by the Finnish Road Administration.

4.4 Value Capture Strategies for the Business Ecosystem

Various methods exist for developing road winter maintenance ecosystems. However, to enhance and co-create the value, joint development of the ecosystem has been seen as the best value capturing strategy so far. Joint development is a strategy that offers synergic benefits for the ecosystem by combining the services or knowhow of different stakeholders into a sophisticated entity. In this sense, successful joint development may improve market efficiency by better linking the costs and benefits of road winter maintenance improvements.

In the existing ecosystem, five ecosystem stakeholders (*meteorological observation device manufacturer; maintenance equipment manufacturer; vehicle location, measurement and tracking solutions provider; meteorology and observation device manufacturer; and road weather and conditions forecast provider*) have seen the potential of carrying out some joint development activities and thus deepening their business relationships. The overall idea is to enhance the development of a next generation decision support system (DSS) that offers accurate and the most recent possible road weather and condition information, thus helping the decision support service provider to deliver better information and recommendations for road maintenance service operators. It is worth noting that taking such a step requires ecosystem members to pull together rather than relying on the trendsetting of lead companies.

The existing DSS acts as a premise for the new system. At present the existing system cannot exploit the incoming information as well it could, or the information is inadequate. Therefore the objective set for the new DSS is to collect the necessary information from those with the most favorable conditions, and finally analyze and refine it in the new system. This approach also enables every participant to focus on their core business and development.

In the new system the role of the decision support system provider remains roughly the same, still focusing on providing road condition forecasts. However, the current ecosystem has some overlap because the weather forecast provider also offers road condition forecasts, although this is not their core business. Thus the two players have decided that the latter will concentrate on weather forecasts while the former continues its focus on road condition forecasts.

Additionally, the maintenance equipment manufacturer has equipped their latest models with different kinds of technology, sensors and meters that collect data during maintenance (e.g. location, friction, temperature, de-icing, performed maintenance activities). Therefore they can provide real-time information about the weather and road conditions to the new DSS. Naturally, the more comprehensive equipping of maintenance equipment increases the demand for sensors and technology and hence provides wider markets for the vehicle location, measurement and tracking solutions provider and meteorological observation device manufacturer.

According to these five stakeholders, the most optimal situation would be for the road authorities or state to procure the new DSS when it is ready. Thus large-scale deployment and usage of the system would be more likely, ultimately manifesting itself in a safer and more reliable mobility market. At the same time, the ecosystem stakeholders could develop the ecosystem further. The risk, however, is that public procurement practices require splitting bids into smaller contracts, which inflates the system packaging efforts of the ecosystem. Hence public sector clients face the difficult dilemma of how to boost innovation and take systems to a new level while maintaining market neutrality and not favoring any given ecosystem over another. Inevitably, there will be pros and cons to whichever direction is taken.

5. Conclusion and Discussion

The conclusions are drawn from our case analysis of the Finnish winter maintenance ecosystem, and from some of the more generic studies on ecosystems. Studies on road weather information systems also contributed. We postulate the following:

1. Business ecosystems are vital in order to deliver not only market-demanded services but also services that are regarded as societal and public.

It seems that the more functions an ecosystem is able to provide, the better prospects there are to integrate these functions into service packages that take service and the satisfaction of user needs to a newer level. Especially in smaller markets, such as Finland, the demand is restricted and the public procurement standards are very specific, even to the extent that it has been identified as a bottleneck for new innovations, and public procurement is set on a high priority in boosting them. This is done not only at national but also at EU level (see e.g. Government of Finland, 2008; European Commission, 2010).

For a winter road maintenance ecosystem such policies are truly good news, but according to our observations, the distance between 'policy talk' and 'practice' is somewhat obvious. Years after the national and EU-level declarations, the practices of public procurement remain relatively unchanged, at least in Finland. Our perception is that there are major differences between countries in how they apply public procurement and how successful they are in this with regard to development of competitive business ecosystems, not only for their domestic markets but also for international competition.

The conclusion on the relevance of public procurement places high expectations on public officials who should at the same time ensure high quality services with acceptable price and facilitate innovation. The risks of innovation procurement are evident, yet few public managers are rewarded for such risk taking. It seems that public sector management systems are lagging behind the technological evolution and changing market conditions. However, the public sector needs capable ecosystems, as they are reducing their operational functions and increasingly relying on the private sector's ability (and willingness) to provide services either through contracts with the public sector or purely market demand.

2. Even small firms that have unique capabilities (offerings) can have a key role in a business ecosystem.

This postulate is self-evident but is extremely relevant in a small-market context, where most of the firms are small anyway. Where niche areas, as winter road maintenance inevitably is, are concerned, the second postulate is well understood. Friction measuring technologies, precise road condition prediction models, and a dedicated

on-the-road fleet are all examples where this uniqueness can be found. This postulate, if true, will open opportunities for small innovative entrepreneurs that can find profitable 'boxes' from larger ecosystems.

For larger firms the capabilities can, apart from technology, be related e.g. to the market position and customer base. This is exactly the situation with the Finnish winter road maintenance business ecosystem. One world leading company sought a partnership with smaller companies to create service packages and systems that are diversifying from the mainstream offerings of its competitors.

3. The capabilities of ecosystems define the service levels and societal gains.

The ecosystems' capabilities, their offerings, and their coherence in sharing common objectives in the provision of services define how good the services are in the end. The coherence is not only about risk and revenue sharing agreements between the supply side of the ecosystem, but also about coherence in client-supplier interfacing. This means that contract models, business models of suppliers, and successful managerial control on issues that are the elements of good service must go hand in hand. Thus it is not only the business players who must play together toward a common goal, it is also the public side. Conflicting interests are inevitably there, but these must be managed on both sides, as well as within the supply and demand side.

For the winter road maintenance ecosystem, contractual arrangements are of paramount interest. Performance based contracts, quality and service level measurement and rewarding mechanisms are intuitively some of those aspects that will have an impact on service levels and how well the level of service is understood by all parties. The more transparent the framework for service quality management is, the greater will be the likelihood of success.

From the technological viewpoint, novel service concepts will likely demand new technological solutions, both at component and system levels. This in turn is facilitated when performance type contracts are adopted. Process based contracts, as has often been repeated, have a tendency to place more emphasis on process efficiency enhancement rather than on underscoring service levels and value for money. And the latter is exactly what healthy ecosystems should be looking for.

4. The emergence and success of ecosystems is a dynamic process requiring a multifaceted responsiveness.

Here we mean that, as stated earlier, the emergence and nurturing of ecosystems requires effort on both sides, both demand and supply. Contractual models are a typical example of this. However, there are further facets to this development. One of the typical mindsets of corporate managers is that their company is on its own and must survive competition against others. This may be the case, but if ecosystems are truly to emerge more extensively, the mindset of managers must focus more on partner seeking and alliance building. No company alone can, for example, offer "everything on winter road maintenance", at least not if we understand the concept as a full-scale management of winter road conditions. Wide-covering contracts are possible, but for example meteorological observations and expertise in interpreting and forecasting road weather conditions must be sought outside road maintenance companies, no matter how diversified they are. Winter road maintenance is and will remain a group endeavor.

As previously mentioned, technology changes must be reacted to and responded to. These changes can be either opportunities or threats to individual companies or even existing ecosystems. Technological drivers are particularly relevant, as they tend to quickly affect engineering businesses, even if winter road maintenance is seldom perceived as a fast-paced tech biz. However, it could well be that. The push in technology will pose managerial challenges in conventional engineering fields, and not only on the private side. Each forward-looking transport agency or road authority should consider having a CTO on their management board.

Finally, as with each product or service, each ecosystem and its services must pass the ultimate market test, the end user. Unless road users (consumers) are 'buying' the service it is difficult to see that an ecosystem would have a promising future. Even if the end customers are not directly paying for the services, in the current world of open media, dissatisfaction will relay to a wider audience and local decision makers.

Acknowledgements

The authors would like to thank the National Technology Agency (Tekes), FIRWE companies, VTT Technical Research Centre of Finland and VTT Graduate School for financing this research work.

References

- Bläsche, J., Kreuz, M., Mühlhausen, T., Schweighofer, J., Leviäkangas, P., Molarius, R., ... Ludvigsen, J. (2011). *Consequences of extreme weather*. Retrieved from http://ewent.vtt.fi/Deliverables/D3/EWENT_D34_v1_0_20111201.pdf

- Cleland, D. I. (1986). Project Stakeholder Management. *Project Management Journal*, 17(4), 36-44.
- Donaldson, K. M., Ishii, K., & Sheppard, S. D. (2006). Customer Value Chain Analysis. *Research in Engineering Design*, 16, 174-183. <http://dx.doi.org/10.1007/s00163-006-0012-8>
- European Commission. (2010). *Europe 2020 Flagship Initiative*. Innovation Union. Communication from the commission to the european parliament, the council, the european economic and social committee and the committee of the regions. sec(2010) 1161, Brussels, 6.10.2010, COM(2010) 546 final.
- Fabre, F., & Klose, A. (1992). *Cost 309: Road weather conditions*. Transport–Research, EUR 13847 EN. Commission of the European Communities. Luxembourg.
- Finnish National Road Administration. (1993). *Tiesääjärjestelmän rakentaminen 1987–1992 [The development of the road weather information system 1987–1992 – in Finnish]*. Kymi road district, Finnish National Road Administration, Kouvola.
- Freeman, E. R. (1984). *Strategic Management: A Stakeholder Approach*. New York, NY: Pitman Publishing Inc.
- Government of Finland. (2008). *Government's Communication on Finland's National Innovation Strategy to the Parliament*. Helsinki.
- Gruening, G. (2001). Origin and theoretical basis of New Public Management. *International Public Management Journal*, 4, 1-25. [http://dx.doi.org/10.1016/S1096-7494\(01\)00041-1](http://dx.doi.org/10.1016/S1096-7494(01)00041-1)
- Herrala, M., Leviäkangas, P., & Haapasalo, H. (2009). Information Value Attributes and Assessment Methods – A Construct from Traffic and Traveller Information Perspective. *Value World*, 32(1), 34-45.
- Iansiti, M., & Levien, R. (2004a). *The keystone advantage: What the new dynamics of business ecosystems mean for strategy, innovation and sustainability*. Boston, MA: Harvard Business School Press.
- Iansiti, M., & Levien, R. (2004b). Strategy as ecology. *Harvard Business Review*, 82(3), 68-78.
- Leviäkangas, P. (2011). Building Value in ITS Services by Analysing Information Service Supply Chains and Value Attributes. *International Journal of Intelligent Transport Systems Research*, 9(2), 47-54. <http://dx.doi.org/10.1007/s13177-011-0029-x>
- Leviäkangas, P., & Ojala, L. (2011). *PPP Research Issues in Finland – What's Up and What's Next*. Public Private Partnerships in Transport: Trends & Theory. COST Action 1001 Symposium, Lisbon, 12 January 2011.
- Leviäkangas, P., Molarius, R., Könönen, V., Hietajärvi, A. -M., & Zulkarnain (2013). Devising and Demonstrating an Extreme Weather Risk Indicator for Transportation System. *Transportation Research Record, Journal of the Transportation Research Board*, 2329, 45-53. <http://dx.doi.org/10.3141/2329-06>
- Leviäkangas, P., Nokkala, M., Rönty, J., Talvitie, A., Pakkala, P., Haapasalo, H., ... Finnilä, K. (2011). Ownership and governance of Finnish infrastructure networks. *VTT Publications 777*. VTT, Espoo, 2011.
- Leviäkangas, P. -M & Hietajärvi, A. -M. (2010). Weather information for transport – the value shift. *Value World*, 33(2), 4-13.
- Molarius, R., Könönen, V., Leviäkangas, P., Zulkarnain, & Rönty, J. (2013). The Extreme Weather Risk Indicators (EWRI) for European transport system. *Natural Hazards*. Springer. <http://dx.doi.org/10.1007/s11069-013-0650-x>
- Moore, J. F. (1993). Predators and prey: A new ecology of competition. *Harvard Business Review*, 71(3), 75-86.
- Murman, E., & Allen, T. (2002). *Lean Enterprise Value: Insights from MIT's Lean Aerospace Initiative*. New York, NY: Palgrave.
- Peltoniemi, M. (2006). Preliminary theoretical framework for the study of business ecosystems. *Emergence: Complexity & Organization*, 8(1), 10-19.
- Pilli-Sihvola, E., Leviäkangas, P., & Hautala, R. (2012). *Better winter road weather information saves money, time, lives and the environment*. In Proceedings of the 19th ITS World Congress, Vienna, Austria, October 22–26. ERTICO (ITS Europe).
- Ramaswamy, V., & Gouillart, F. (2010). *The power of co-creation: Build it with them to boost growth, productivity, and profits*. New York, NY: Free Press.
- Ritchey, T. (2002). *Modelling Complex Socio-Technical Systems Using Morphological Analysis*. Adapted from an address to the Swedish Parliamentary IT Commission, Stockholm, December 2002. Retrieved from

<http://www.swemorph.com/pdf/it-webart.pdf>

- Rubenstein-Montano, B., Liebowitz, J., Buchwalter, J., McCaw, D., Newman, B., & Rebeck, K. (2001). A systems thinking framework for knowledge management. *Decision Support Systems*, 31(1), 5-16. [http://dx.doi.org/10.1016/S0167-9236\(00\)00116-0](http://dx.doi.org/10.1016/S0167-9236(00)00116-0)
- SAVE International. (2007). *Value Standard and Body of Knowledge*. SAVE International Value Standard, 2007 edition.
- Strong, C. K., Ye, Z., & Shi, X. (2010). Safety Effects of Winter Weather: The State of Knowledge and Remaining Challenges. *Transport Reviews*, 30, 677-699. <http://dx.doi.org/10.1080/01441640903414470>
- Walter, A., Ritter, T., & Gemünden, H. G. (2001). Value creation in buyer-seller relationships. *Industrial Marketing and Management*, 30, 365-377. [http://dx.doi.org/10.1016/S0019-8501\(01\)00156-0](http://dx.doi.org/10.1016/S0019-8501(01)00156-0)
- Weiller, C., & Neely, A. (2013). *Business model design in an ecosystem context*. University of Cambridge, Cambridge Service Alliance.
- Winch, G. M. (2004). Managing project stakeholders. In P. W. G. Morris, & J. K. Pinto (Eds.), *The Wiley guide to managing projects* (pp. 321-329). New Jersey: Wiley.
- Yourdon, E. (1989). *Modern Structured Analysis*. Upper Saddle River, NJ: Yourdon Press.
- Zulkarnain, & Leviäkangas, P. (2012). The size, structure and characteristics of Finland's ITS industry. *Technology & Investment*, 3(3), 158-167. <http://dx.doi.org/10.4236/ti.2012.33022>

Copyrights

Copyright for this article is retained by the author(s), with first publication rights granted to the journal.

This is an open-access article distributed under the terms and conditions of the Creative Commons Attribution license (<http://creativecommons.org/licenses/by/3.0/>).

ARTICLE IV

**The electric vehicles ecosystem model:
Construct, analysis and identification of
key challenges**

Managing Global Transition:
International Research Journal 12(3): 253–277.
Copyright 2014 Authors.

The Electric Vehicles Ecosystem Model: Construct, Analysis and Identification of Key Challenges

Zulkarnain

VTT Technical Research Centre of Finland, Finland

zulkarnain@vtt.fi

Pekka Leviäkangas

University of Oulu, Finland

pekka.leviakangas@oulu.fi

Tuomo Kinnunen

University of Oulu, Finland

tuomo.kinnunen@oulu.fi

Pekka Kess

University of Oulu, Finland

pekka.kess@oulu.fi

This paper builds a conceptual model of electric vehicles' (EV) ecosystem and value chain build-up. Based on the literature, the research distinguishes the most critical challenges that are on the way of mobility systems' electrification. Consumers still have some questions that call for answers before they are ready to adopt EVs. With regard to technical aspects, some challenges are coming from vehicles, charging infrastructure, battery technology, and standardization. The use of battery in EVs will bring in additional environmental challenges, coming from the battery life cycle for used battery, the manufacturing, and from some materials used and treated in the manufacturing process. The policy aspects include mostly taxation strategies. For most part, established market conditions are still lacking and there are a number of unresolved challenges on both supply and demand side of the EV market.

Key Words: electric vehicles, ecosystem, mobility, policy, environment

JEL Classification: L22, L62, O18, Q01, R41

Introduction and Scope

A vast number of studies on electric vehicles (EVs) have been issued up to date and the reasons for this are obvious, as the movement towards electrification of mobility is gaining strength as part of greening the transportation systems. This paper introduces a conceptual model of the EV

ecosystem – the relevant stakeholders and actors – and identifies the key challenges of EV market penetration. EVs have potential to change the nature of the whole vehicle manufacturing business and the ecosystem around current fuel-powered vehicles (cf. Petrie 2012). EVs use one or more electric motors as their power sources either directly powered from external power station, or powered by an on-board electrical generator. EVs include plug-in electric cars, hybrid electric cars, hydrogen vehicles, electric trains, electric lorries, and electric motorcycles/scooters.

Many countries are considering what electrification of their mobility system in fact means. Furthermore, these countries are not completely aware of their current industrial structure and how EV industry will complement the existing industry architecture. EV industry needs an ecosystem that is able to deliver necessary technologies, services and processes that facilitate EVs to penetrate the market. The ecosystem consists of both public and private actors, but the ex-ante presumption is that private actors are more dominant in the making of EV ecosystem works. Tax and energy policies are not the least of these issues, but are consciously framed outside the analysis. In addition, trade policy issues remain visible in the background context.

The policy of the European Union has been to promote electrification of the mobility system, although the related directive on the promotion of clean and energy-efficient road transport vehicles leaves much room for member states to apply (European Commission 2009). A particular emphasis is put on public procurement of vehicles, which puts weight on public transport vehicles, e. g. buses or some other vehicle fleets in public service. On taxation or other promoting measures, the directive speaks only little, and stays only on promotional level. If the policies are to be efficient, specific and targeted measures need to be taken in order to make EVs more lucrative for both consumers and producers.

This paper draws from the existing body of literature some of the key challenges on the way of electric mobility. The structuring of the challenges summarizes existing research and points out whether the challenges are mainly arising from the market, policy or business, or whether they have more of a technical or societal (environmental) nature. Literature base and systems modelling are used as research approaches to main research questions that are stated as follows:

1. What are the key challenges of EVs' wider acceptance by the market and consumers and how these challenges can be categorized?

2. What is the current electric vehicle ecosystem (or cluster) looking like and how do the main challenges relate to the ecosystem?
3. Can we identify prospective development paths that would pave the way for EVs and speed up the electrification of the mobility system?

In order to answer the above research questions, the study focuses on the ecosystem level view that comprises set of companies or industries with their functions, roles, and dynamics. Firm level analysis is excluded as it would require higher resolution focus on firms' business models. The research process was divided into four steps:

1. Reviewing and clustering of the literature and disaggregating the clustered themes into major challenges regarding EV markets based on the researchers' perception derived from the literature.
2. Identification of relevant actors and stakeholders and constructing a generic EV ecosystem description.
3. Reflecting the major (but disaggregated) challenges against generic electric vehicles ecosystem (EVE) and 'mapping' the challenges in the EVE architecture.
4. Concluding and presenting some of the relevant steps to overcome the identified and mapped challenges.

Methodologically, reviewing of the literature and extracting the relevant key challenges that are on the way of mobility systems' electrification and building visual representative models can be regarded as heuristic modelling of the phenomenon (EV ecosystem), i. e. problem solving or increasing the understanding of the problem (Frigg and Hartmann 2012). The tree-like hierarchy of challenges built around clusters (i. e. themes) are a logical continuation of this method. The devising of the ecosystem description is constructive research by nature. We construct the ecosystem model in order to scale-down complex reality. In some countries, the ecosystem model finds empirical objects that correspond to the elements of the construct, but in some countries, the ecosystems are undeveloped or unconscious of the needed actions to be taken. Thus the research process consists of exploratory part (literature review) and constructive parts, which are partly heuristic (modelling of ecosystem and challenges) and partly empirical (ecosystem description and analytics).

The authors gathered literature on EV from year 2009 onwards. The catch was about 50 articles altogether published in peer-reviewed journals or other well-established references, from which the authors selected the

prominent ones. The key selection criteria were (i) good quality journals, (ii) preference for holistic rather than focused theme and/or approach, (iii) exclusion of explicitly vehicle technology-focused material.

After the initial phase of the literature review, the source material was clustered in four main categories of research: (1) consumer aspirations and preferences, (2) EV policy deployment, (3) business models in EV ecosystem, (4) environmental issues associated with EVs. After reviewing the references, the authors mapped conceptually the key challenges that seem to be posing on wide-scale deployment and market penetration of EVs. For the ecosystem description, a typical systems analysis and system modelling was adopted. One can refer to ‘a model,’ ‘architecture’ or ‘a design,’ but in essence, the result is a visual illustration of the EV ecosystem stakeholders and how they build the value chain for EV market. We call this the EVE (Electric Vehicles Ecosystem) model. The model is also a morphological approach in order to give shape and structure to a complex socio-technical system (Ritchey 2002).

The work was performed as part of Finland’s EVs national test site programme that comprises several small-scale test sites in different parts of the country (see <http://www.tekes.fi>).

Literature Brief

WHAT ARE (BUSINESS) ECOSYSTEMS?

Business ecosystems address business opportunities that require a diverse set of capabilities to meet customer needs that are beyond the capability of any single company (Carbone 2009). Compared to a single company, a business ecosystem can invest more resources and tolerate higher risk through cost sharing, integrate broader set of diversified capabilities and develop broader set of products (Iansiti and Levien 2004). Business ecosystems work for incorporating the next round of innovations by (Moore 1993) bringing synergies of different companies and public actors together towards a common innovation. The ecosystem perspective emphasises actors’ co-evolving relationships and dynamic nature of business networks (Hearn and Pace 2006). There is a shared fate of the involved actors and need to understand organization’s own role in the ecosystem. The most relevant and strong actors or stakeholders could have three alternative roles within the ecosystems: *a keystone* who improves overall health of the ecosystem, *a classic dominator* who leaves little opportunity for emergence of a meaningful ecosystem, or *a value dominator* who captures most value for itself leaving a starved and unstable ecosystem

around it (Iansiti and Levien 2004). Actors' competitive and cooperative interactions advance the ecosystem coming up with new offerings and satisfying customer needs (Moore 1993). Thus, actors in a co-evolutionary relationship activate selective pressure towards others and influence consequently each other's evolution (Corallo 2007). In an ideal ecosystem, actors share resources, knowledge and technologies across the ecosystem providing basis for holistic value creation via the ecosystem (Hearn and Pace 2006). Each organisation adds its distinct aspects of offering to the value generated by the ecosystem and share the total value created by the ecosystem (Camarinha-Matos et al. 2009). Productivity of the ecosystems can be measured by networks' ability to consistently lower costs and launch new products.

In emerging ecosystems, such as the EV ecosystem, central companies typically focus on working together with essential stakeholders, such as lead customers, key suppliers and channels, to: (1) define new customer value propositions based on innovation; (2) determine how to deliver and implement the customer value propositions; and (3) design business that serves the potential market (Moore 1993). EV ecosystem has been competing against fuel-powered vehicle ecosystem for a while without significant global success, and most likely much due to the dominance of key stakeholder, i. e. the vehicle manufacturing industry. For other stakeholders, the market and negotiation power is significantly lower. Thus, the EV ecosystem is not yet providing good enough business cases for the most of the customers and, consequently, cannot capitalize its market potential (e. g. Petrie 2012). The grand challenge of the EV ecosystem in this competition is to change this status quo by creating compelling customer value propositions, which, by itself, facilitate the emergence and growth of thriving global business ecosystem. At next, challenges related to EV ecosystem performance are studied based on the literature to facilitate the EV ecosystem description and analysis.

SELECTED EVS STUDIES AND IDENTIFIED CHALLENGES

A number of studies on consumer views of EVs will cover several aspects i. e. consumer willingness to pay, attitude and behaviour, awareness, and preferences that seem to be crucial to push EVs into the market. Hidrue et al.(2011), Skippon and Garwood (2011), Axsen, Kurani and Burke (2010), Lieven et al. (2011), Zhang, Yu and Zou (2011), and Zulkarnain et al. (2012) have taken part in some studies in term of consumer aspirations and preferences of the EV.

Hidrue et al. (2011) point out that in the US the consumers are concerned with EVs' driving range and vehicles' availability because of the needed charging time. In addition, the consumers seem to be uncertain on the potential fuel savings, which is one of the obvious arguments for EVs. Without subsidies, the battery costs are also considered too high. The same concerns were expressed by the consumers in the UK: driving range, cost savings and charging options (Skippon and Garwood 2011). Axsen, Kurani and Burke (2010) particularly raise the question on battery technology's maturity and whether that meets the consumers' expectations – their results point out these expectations will not be met in the near future at least. In Germany, a study by Lieven et al (2011) concluded that about 5% of the potential consumers would be ready to choose EV as their primary car. Hence, the total volume of the market was not that significant, as the 5% share would be divided by several manufacturers. However, it must be noted that these figures might quickly change over short period. In China, the consumers' awareness of EV options is still limited, as reported by Zhang, Yu and Zou (2011). This indicates that the emerging markets might not be ready for larger scale EV penetration, in particular if the market potential for conventional vehicles is still far from unsaturated and the level of motorization still low. Zulkarnain et al. (2012) point out that the EV industry is in its infancy, but possesses great potential according to market surveys and business intelligence reports. The test sites are already emerging around the globe. Once the market penetration starts to take place seriously, the early actors are in the best competitive position, if they have been able to successfully pilot their own concepts.

Perujo and Ciuffo (2010), Kang and Recker (2009), Camus, Fariau and Esteves (2011), Schill (2011), Hong et al. (2012) and Crist (2012) have studied EV policy needs and options. The charging of EVs will not have any significant effect on annual energy consumption according to Perujo and Ciuffo (2010), but the daily and hourly electricity demand in turn might require some regulation or at least demand-based pricing in order to even out demand peaks. Camus, Farias and Esteves (2011) reached about the same conclusion regarding on-peak and off-peak pricing, as well as did Schill (2011). Peak-time demand will reduce the consumer surplus of EVs from purely economic point of view, either through pricing or increased need of supply capacity. Both, Perujo and Ciuffo (2010) and Camus, Farias and Esteves (2011) point out positive impacts on CO₂ emissions. Despite of possible reduced economic gains due to sharper peak-time demand

of electricity and/or demand-based pricing, the public subsidies can still pay-off from the societal perspective. Hong et al (2012) claimed that in South-Korea with 1 trillion won government subsidy to services for grid-to-vehicle would result in almost 2 trillion won of social welfares and additional 2 trillion increased profits for service operators' profits. In their analyses, they included in social welfare: (i) expansion of charging infrastructure, (ii) increase in peak time electricity sales, (iii) fuel cost savings. The last mentioned was actually the most explicit benefit from the macro-economic viewpoint (as Korea is an importer of oil). They also included externalities (CO, CO₂ and NO_x) but did not price them. The most efficient way of maximizing the social welfare was tax incentives. Crist (2012) analyses the differences between BEVs and internal combustion engine (ICE) vehicles and finds out that under the French tax regime and subsidy system the government revenues over the life cycle of the vehicles are not very far from each other but still favouring ICES over BEVs. Furthermore, the comparison result is highly dependable on how and where the initial electricity is produced.

Recent studies on EV industry and business are presented by Kley, Lerch and Dallinger (2011), San Roman et al. (2011), and Andersen, Mathews and Rask (2009). Kley, Lerch and Dallinger (2011) identified three sub-ecosystems or components for the EV ecosystem and devised an approximate descriptive model for the ecosystem. San Roman et al (2011) identified two roles or functions in the ecosystem that were needed for efficient market structure, whereas Andersen, Mathews and Rask (2009) showed that EVs could be used as distributed electricity storages when not in use. This in term would call for intelligent electricity grid. The scarcity of this literature is obvious but understandable as so many technical issues remain to be solved and regulated. The ecosystem in itself starts to be visible, even if some new roles or functions could be needed in the future.

Browne, Allen and Leonardi (2011), Thomas (2012), Zackrisson, Avelán and Orlenius (2010), and Lucas, Silva and Neto (2012) have conducted their own research regarding to environmental issues of the EV. At the same when EVs have great potential to reduce CO₂ emissions (Browne, Allen and Leonardi 2011, Thomas 2012), Lucas, Silva and Neto (2012) suggest that EV energy supply infrastructures are more energy consuming than those of conventional vehicles,' when looking at the whole life cycle of infrastructures. Furthermore, the batteries' life cycle analysis is still somewhat open, but more than 50% of the batteries' carbon footprint

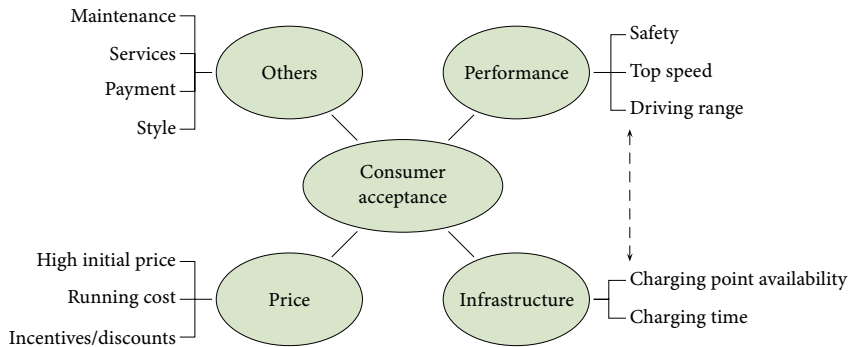

FIGURE 1 Consumer Acceptance Challenges

is generated by their manufacturing (Zackrisson, Avellán and Orlenius 2010). The recycling issues have not been yet thoroughly addressed.

The summary of reviewed literature on EVs is presented in table 1.

Building the Hierarchy of the Challenges

CONSUMER ACCEPTANCE

In this early stage of EVs development, consumer acceptance is one of critical aspects that need to be paid attention. A number of consumer surveys show a promising market for EVs when there is a group of people, called EVs adopters, who have willingness to buy EVs as next generation vehicles. However, some challenges coming from the consumer perspectives are still present. Consumers still have some questions that call for answers before they are ready to adopt EVs. These questions relate to the price, performance, and infrastructure, among others (figure 1).

As to price aspects, the high initial price to buy an electric vehicle still becomes one of the major inhibitors. This is mainly caused by high battery costs – 48% of total price (MEC Intelligence 2011). Moreover, the running cost for the EVs are still uncharted. Incentives provided by governments have been brought forth in several countries, for instances in EU environmental zones (e. g. London, Berlin and Stockholm) that offer attractive incentives for EV drivers such as: free public parking, allowed to use bus lanes, no road taxes and free ferry transport. However, some studies indicated that the government incentives' impact on the adoption of EVs is still relatively low (e. g. Diamond 2009 and Jenn, Azevedo and Ferreira 2013).

Other challenges are coming from EVs' performance, i. e. safety issue,

TABLE 1 Summary of Reviewed Literature on EVs

Consumer and market views to EVs	WTP for EV and their attributes: (1) Driving range, charging time and fuel cost saving; (2) Significantly drop battery cost is required to attain competitive market without subsidy.	Hidrué et al. (2011)	Stated preference, choice experiment, internet based survey
	Responses to battery electric vehicles (BEV): UK consumer attitudes and attributions of symbolic meaning following direct experience to reduce psychological distance. (1) Would consider BEV as a main car if it has 150 miles range and as a second car for 100 miles range; (2) Willing to buy BEV over conventional vehicle for equivalent 3 years running cost saving; (3) Prefer credit/debit card and electricity bill as payment.	Skippon and Garwood (2011)	Direct experience, questionnaire, vignette exercise
	Who will buy electric cars (Germany case study): 5% of total buyer will choose EV as their main car.	Lieven et al. (2011)	Stated preference, online survey
	Market potential is still projected to be significant, but the real growth has not yet taken place; test sites are active around the globe.	Zulkarnain et al. (2012)	Review of market surveys, business intelligence reports and test sites
	Battery technology is not meeting the consumers' expectations concerning the costs, power, longevity and safety.	Axsen, Kurani and Burke (2010)	Consumer survey, analysis on battery technology
	Analysing public awareness and acceptance of alternative fuel vehicles (EV) in China. (1) Factors influencing consumers' purchase willingness: purchase time and purchase price; (2) Limited acquaintance of EVs in China- different influences on consumer behaviour.	Zhang, Yu and Zou (2011)	Questionnaire
EV policy deployment and impacts	Impact of EVs recharging activities on the electric supply system in Milan for 2030 time horizon: (1) In the future, with high market penetration the impact on annual energy consumption will quite negligible; (2) For daily electric power request, appropriate regulation is needed (e. g. smart grid)	Perujo and Ciuffo (2010)	Forecasting and simulation

Continued on the next page

TABLE 1 Continued from the previous page

Potential energy profile impact on PHEVs deployment in the US: (1) Circuit upgrades bring faster charging time and less charging time difference between PHEV20 and PHEV60; (2) Home charging and public charging benefits to serve travel distance and mileage conversion to electricity.	Kang and Recker (2009)	Activity-based modelling, simulation
Impact EVs penetration on load profiles, electricity prices, and emission for scenario 2020 in Portugal: (1) Electricity prices of 20 cents/kWh for high hydro production and peak hours scenario with 2 million EVs, and energy costs of 5.6 cents/kWh for low hydro production and off-peak hour scenario; (2) Up to 10% CO ₂ emission reduction are obtained.	Camus, Farias and Esteves (2011)	Simulation
The effects on price, welfare, and electricity generation: (1) Uncontrolled vehicle recharging could increase evening peak loads and prices; (2) Arbitrage capability of unused battery will smooth electricity price and increase consumer surplus; 3) Increased utilization of generating technologies because of controlled loading of EVs.	Schill (2011)	Game theoretic model
Comparison of BEVs and ICEs show no great differences in government total revenues when analysed under French tax regime; the life-cycle emissions between BEV and ICE are slightly in favour of BEVs.	Crist (2012)	Socio-economic cost analysis
Ex-ante evaluation of profitability and government's subsidy policy on V2G system in Korea: (1) The maximum profit for a V2G service provider will be 1.27 trillion Korean won/year with an annual subscription fee of 0.65 million Korean won; (2) The government subsidy of 1 trillion Korean won, given annually, will increase social welfare by 1.94 trillion won and also boost the profit of vehicle-to-grid service provider to 1.98 trillion won.	Hong, Jeong and Lee (2012)	Conjoint analysis and simulation

Business models and regulatory framework	A new business model for electric cars – a holistic approach. Three components were considered: the vehicle including the battery, infrastructure and system services	Kley, Lerch and Dallinger (2011)	Morphological box
	Regulatory framework and business models for charging plug-in EVs: (1) Two new agents: EV charging manager, and EV aggregator were introduced; (2) Main charging modes: home charging, public street, dedicated charging stations; (3) V2G services regulatory framework was also presented.	San Roman et al. (2011)	Constructive approach
	Overview of Electric Recharge Grid Operator (ERGO) business models – intelligent charging grids for EVs: ERGO business models could solve problems of power grid utilization and fluctuating supply, and CO ₂ emissions problem, by transforming EVs into distributed storage devices for electricity.	Andersen, Mathews and Rask (2009)	Exploratory
Environmental issues related to EVs	Evaluating the use of an urban consolidation centre and EVs in Central London: (1) Total distance travelled decreases by 20%; (2) CO ₂ emissions reduction of 54%.	Browne, Allen and Leonardi (2011)	Trial evaluation
	How green are EVs? At most 25% GHG reduction and less than 67% oil consumption reduction resulted in replacing all vehicles with BEVs or PHEVs.	Thomas (2012)	Argonne National Laboratory GREET model
	Life cycle assessment of Lithium-ion batteries for PHEVs: (1) Energy use in battery manufacturing dominate the global warming impacts (>50%), followed by electronics (30%) and cathode (10%); (2) There will be decreasing production phase environmental impacts due to improvement of recent battery technology.	Zackrisson, Avellán and Orlenius (2010)	ISO 14044 environmental management & the International Environmental Product Declaration EPD® system
	Life cycle analysis of energy supply infrastructure for conventional and EVs: EV supply infrastructures (construction, maintenance, decommissioning) are seen to be more carbon and energetic intensive than conventional vehicles' energy supply infrastructures.	Lucas, Silva and Neto (2012)	Global warming potential and cumulative energy demand calculation; Monte Carlo

top speed limitation, and the driving range. The latter one still becomes key challenge for many consumers especially for those who need long range mobility (see e. g. Franke and Krems 2013). Besides the battery performance, the availability of charging infrastructure is somewhat associated with the driving range performance. If there were more charging points available, this would extend the driving range. Other aspects also exist, such as the top speed limitation and safety issue. However, the challenges do not end here. Long charging time is still considered as the matter by consumers.

Other aspects related to user experience, method of payment (mainly charging), style of vehicle (e. g. design, existentialism) and maintenance services (accessibility, quality, etc.) are likely found too, but these are not on the top list, at least yet.

TECHNICAL ASPECTS: INFRASTRUCTURES

With regard to technical aspects, some challenges are coming from vehicles, charging infrastructure, battery technology, and standardization (figure 2). Vehicles' challenges are in the designing of EVs to meet the consumers' requirements properly. The design deals with the performance, style, etc. that calls for new types of industry value chains compared to the old automotive industry structure. Several new cooperation contexts are needed, e. g. between OEM and battery manufacturers or charging manufacturers, to deliver their products and services. Besides, the impact of EV deployments to the electricity consumption has also been a concern of the stakeholders, i. e. how to manage the distribution of power, especially in peak hour period. Smart grid/intelligent solutions are currently believed to be one of the answers to this challenge. Vehicle-to-Grid (V2G) technologies have been also in development focus, for the same reasons. V2G technologies are enabling EVs to communicate with the smart grid to either delivering electricity into the grid or to throttle back their charging rate.

According to most experts, even if there are challenges concerning infrastructure, the most profound problem or bottle neck for EVs is the battery. This is mostly because of the battery costs. Production costs of electric vehicle today are about 2.5 times higher than of one with combustion engine (Koskue and Talka 2010). Several battery technology challenges must be solved, such as reduction in weight, volume, charging times, dependence on operating temperature, and the use and treatment of toxic components. The latter will pose an issue when disposing the

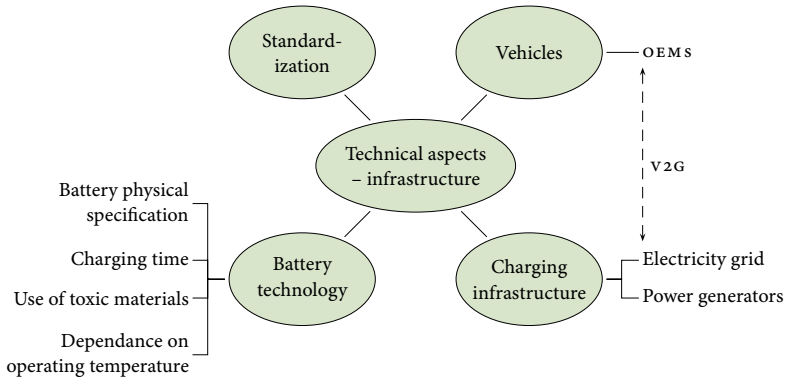

FIGURE 2 Technical Challenges

batteries. The disposal system needs to be established and financed in the end.

Standardization and regulation issues are also imperative. Standards and technical norms have to be created to ensure that the vehicles can be easily connected to the power network in order to recharge the energy storage system. The goal should be of course global standards in order to avoid technological islands to achieve economies of scale. For the EU, these questions are of relevance in order to avoid a fragmented pattern of locally competing and incompatible solutions.

ENVIRONMENTAL CHALLENGES AND POLICY/ REGULATORY ISSUES

Electric vehicles (EVs) are believed to be more environmentally accepted than conventional vehicles and they could reduce the fuel oil dependency. The latter is seen partly as a climate change challenge but also as a trade policy issue. However, a closer examination will bring in other critical questions to be answered, e. g. concerning the battery and power supply infrastructure (figure 3). Environmental aspects are, as said, tightly associated with tax policies and other incentives for wider adoption of EVs. Carbon based taxes have been introduced in many countries across the globe.

The use of battery in EVs will bring in additional environmental challenges, coming from the battery life cycle for used battery, the manufacturing, and from some materials used and treated in the manufacturing process. The disposal system for used batteries needs to be established and financed in the end. Moreover, power supply infrastructure has also

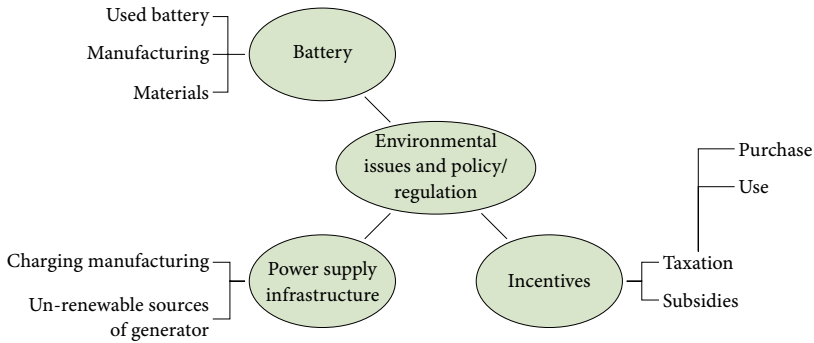

FIGURE 3 Environmental Challenges

potential environmental problems that might be caused by the increasing use of un-renewable sources of electricity generation. If renewable sources for production are used, the problem is solved, however. The last probable challenge is coming from manufacturing of charging infrastructure, though this issue still needs further investigation.

Electric Vehicles Ecosystem (EVE) Model

EV STAKEHOLDERS IDENTIFICATION

Giannoutakis and Li (2011) conducted a stakeholder analysis for Intelligent Transport Systems (ITS). They identified government and policy makers, funding bodies, transport group and organizations, ITS designer and manufacturers, automobile suppliers, key shareholders, energy sector, environmentalists, local authorities and users. This list was applied to large extent to map relevant EVs stakeholders. The EVs ecosystem (EVE) model is constructed by mapping the EVs stakeholders within the ecosystem and defining the relationship among the actors (figure 4). The EVE model includes the following main players:

- EVs end users: the key consumers who use EVs for their mobility. They comprise consumers, corporate customers, and public sector. Customer acceptance challenges apply for the EVs end users and determine the critical success factor for EVs deployment.
- Power utilities and infrastructures (PUI): the EVs-enabler facilities, i. e. charging points, power network providers, electricity producers, fuel suppliers (for hybrid-type of EVs), including their upstream value chain actors.

- EVs manufacturers (EVM): the key motor in EVE that contains EVs manufacturers (OEM), EVs suppliers, component suppliers and their related services providers (e. g. mobility/telematics service providers and EVs rental service providers).
- Battery suppliers (BS): including battery manufacturers, component suppliers, and related R&D. Together with power utilities/infrastructures and EVs manufacturers, they deal with identified technical aspect challenges.
- Regulators and external actors (REA): Policy makers/regulators from any levels of governments, e. g. inter-governmental bodies, regional, member states, municipalities and local authorities; EVs-related industry association, academic research and development, and environmentalists as ‘catalysts’ for EVs policy deployment.
- EVs aggregators/integrators (EVAI): a system integrator that is proposed to be a key operator for the ecosystem. The integrator can be one of the existing players, an entirely new one or a combination of both (e. g. a joint venture). This new player was introduced by e. g. in San Roman et al. (2011). A real-world corresponding example of this actor was BetterPlace, which after implementing the first modern commercial deployment of the battery swapping model in Israel and Denmark, later filed bankruptcy in Israel (SmartGridToday 2013). The EVs aggregator/integrator is driven by regulators and integrating/coordinating the roles of the main actors in EVE.

The value chains of each main layer include the actors that have a stake in EVE. The value adding flows obviously represent product/service offerings, cash flows (the opposite direction), contractual relationships or some other type of interaction of relevance. This ‘multilayer stakeholder mapping’ not only shows the ecosystem but also the interactive links between ecosystem stakeholders and the value creation process of the ecosystem. Furthermore, the colouring of the map shows which of the stakeholders are in key position as cornerstones, classic dominators or value dominators. It is not always clear yet how these roles will be in the end and the casting could well change from country to country, or even locally.

EV ECOSYSTEM ANALYSIS

The identified key challenges of electro-mobility system are reflected in EVs ecosystem model (figure 4). The consumers’ acceptance challenges

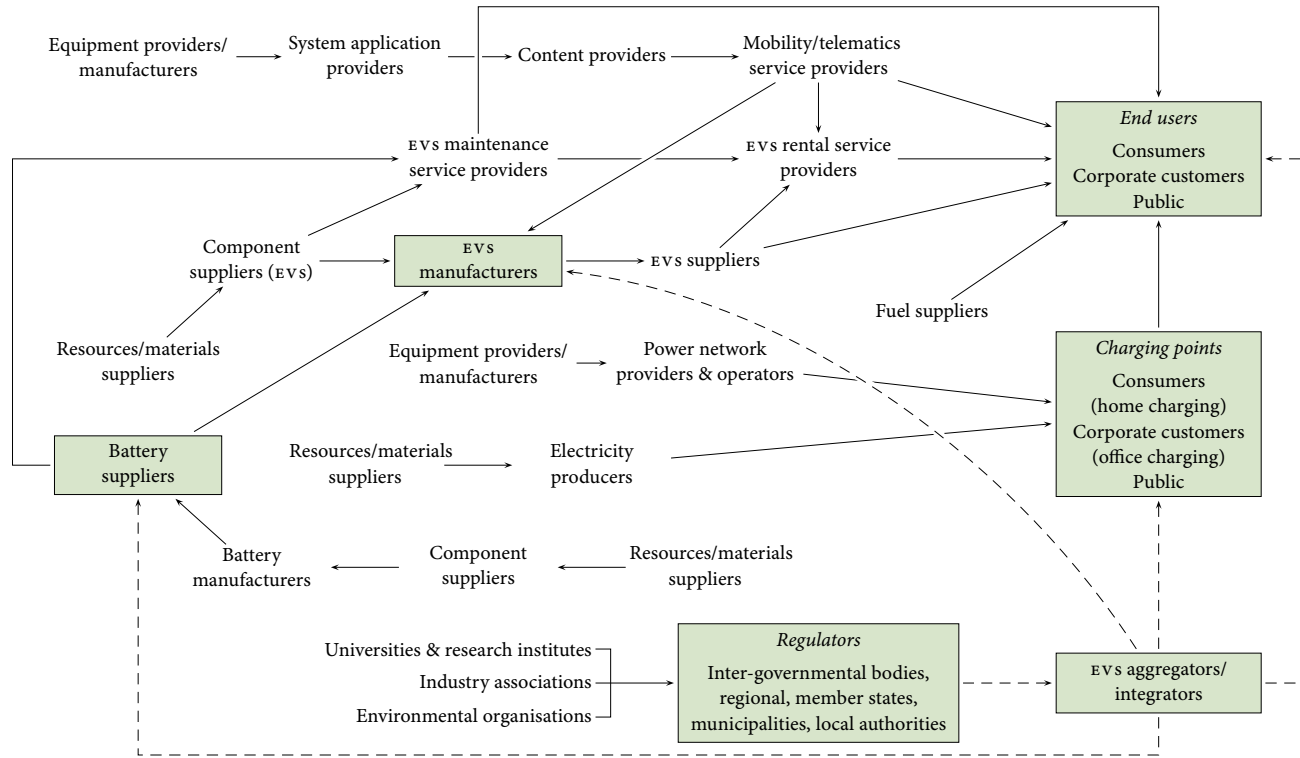

FIGURE 4 Electric Vehicles Ecosystem (EVE) Model (solid – current offerings/actors, dashed – future offerings/actors)

form perhaps the gravest obstacle from the demand side concerning EVs' market penetration. But this demand side challenge is not independent but intertwined with supply side impediments: price, performance, and infrastructure readiness and other related services are considered by the users prior the prospective purchase of an EV. The technical aspect challenges (supply-side as well) concern the EVs manufacturers' ability to meet some of the consumer demands, the battery producers' sustainable, durable and available (e. g. replacing) solutions. The electricity infrastructure providers are clearly in a decisive role as enablers of EVs market penetration and having the power to pull one critical obstacle from the way. How dominant exactly this position is, remains to be seen and depends on policies that pave the way over the critical period of time when demand of electricity for EVs does not yet solve the investment equation for the utilities and power infrastructure companies. All the aforementioned challenges are crucial, but their inter-dependencies will make both business and policy planning an exercise, where very careful pacing is called for. Technology immaturity is the main reason behind the high EVs price, whereas insufficient performance and infrastructure readiness are the factors that concern the customers. For long run, the environmental issues related to the manufacturing process of the vehicles, life-cycle treatment of batteries and the sources of energy need to be tackled as well. Failure to do so will undermine the arguments for EVs, not matter how sound they might appear from the surface. For example, the battery recycle problem and the rising use of fuel for generating electricity are believed to have the opposite effect on decarbonizing targets. The master driver for EVs seems to be the automotive industry, which is not a surprise. They have the cornerstone role without which the ecosystem shall not exist. Two other evident keen actors are the battery suppliers and energy utilities, particularly those who own their networks and not only the production facilities. Battery suppliers seem to fit to the role of value adding dominator, since their technology will to large extent dictate the fate of EVE, but their dominance potential – at least so far – looks restricted. They enter the ecosystem with their technology only unless they come up with innovative service ideas that enable radical expansion of the EVs market. The rest of the actors are undoubtedly contributors to EVE but their dominance potential is minimal.

Both the automotive sector and the utilities have a strategic expansion potential in the value network of EVs and they equally can have dominating roles. Both have prospects to lower customer acceptance chal-

lenges. Table 2 highlights the principle B2B dynamics between ecosystem's stakeholders.

It is obvious, that along with the EV manufacturing industry the regulators are in the key position. With the support of the two, the ecosystem can exist, and without it, the ecosystem will die, if emerged at all. The case of BetterPlace serves as a good example. A modern business case of EV aggregator/integrator that had been grown promisingly and believed in by many market analysts, considered as a great innovation on accelerating the EV market acceptance. However, it was the lack of support from the keystone actor in EV ecosystem, the vehicle manufacturers, that was believed to be as the main reason to the bankruptcy of BetterPlace. Apparently, only 950 cars fitted with Better Place's replaceable battery technology were sold since 2012 and the only carmaker to sign on with Better Place was Renault. According to some views (e. g. Lunden 2013), creating a breakthrough technology that relies on industrial-scale overhaul is capital intensive to start with, and further there is the question of critical mass for electric car technology. This could be regarded as a preliminary indication that strengthens our hypothesis – as well as the inevitable observation – on automotive industry's key role.

The integrators, whoever they could be, seem to have a good position to address the technical challenges by being in the centre of the stakeholder group that are facing them. Therefore, a proactive role from their side might have a good boosting effect on EVE's growth and flourishing in business sense. Nevertheless, if they are moving too early and the EV manufacturers are not ready for up-scaling EV business, the manufacturers can easily block these efforts. The more time passes and technologies mature, however, the lesser role the manufacturers could have. In time, the batteries' prices will be falling, more environmental taxes will likely be levied on transport that will favour the mobility system's electrification, and the infrastructures are developed to facilitate EVs on a larger scale. Therefore, and in our opinion, it is in the EV manufacturers' interest to move in fact rapidly towards electrification as they still have most of the strategic advantages on their side.

The new potential actor in the EV ecosystem is mobility services/digital information services provider. This actor provides in-vehicle system services for e. g. information of charging station location, charging status, and payment services for vehicle charging. These features will ease the EV drivers in operating their cars and increase customer convenience. This potential could expand the business ecosystem of EV since it will in-

TABLE 2 EVE Stakeholders' Relationship Matrix

(1) EV manufacturers (EVM)	(2) Battery suppliers (BS)	(3) Power utilities & infrastructures (PUI)	(4) Regulators & external actors (REA)	(5) EV aggregator/integrator (EVAI)
(1)	EVM provide the main customer base	EVM provide significant new market segment and increased demand	EVM are a subject of regulation, yet with substantial negotiating power	EVM provide the main collaborator for prospective EVAI, but may also through their market power pursue the role of EVAI
(2)	BS provide key technology without which the ecosystem would not exist	BS provide potential new collaborators but also an alternative supply source which can mean competition as well in some situations	BS are a subject of regulation especially when considering the life cycle treatment of batteries	BS could be a valuable collaborator or the two roles could be integrated easily when battery rental business models are considered
(3)	PUI provide technical framework under which EVM must operate and that will frame the market conditions as well	PUI provide also here both the market and technical restrictions which will affect BS	PUI are a subject of regulation but with substantial negotiation power; however, the PUI are not the primary subject of REA	PUI provide also here both the market and technical restrictions which will affect EVAI
(4)	Provide guidelines, regulation and policy framework	Provide guidelines, regulation and policy framework		Provide guidelines, regulation and policy framework
(5)	Build B2B contractual relationship with EVM or directly with consumers in the rental schemes; hence they might have either positive or negative impact on EVM and BS, depending on what the latter's strategy is	Build B2B contractual relationship regarding e. g. charging stations	EVAI are a subject of regulation, with no substantial negotiation power unless they are aligned with e. g. PUI; however, EVAI are not likely the primary subject of REA	

volve a number of industries – called ITS (Intelligent Transportation System) industry – that comprises equipment provider, content/application provider, and service provider (see Zulkarnain and Leviäkangas 2012). Furthermore, there are still some other relevant actors that might be considered as part of the EV ecosystem. They are battery recycling companies, vehicle testing services providers, used car dealers, telecommunication service providers, insurance companies and investment/finance institutions. The latter will play any important roles e. g. in the procurement and purchasing of new EVs, loan and leasing, and rental systems. However, to reduce the complexity of the EVE model, we decide to exclude them and their value chain on our existing model.

Conclusion and Policy Implications

The most important issues or challenges regarding the market penetration of the EVs are associated with infrastructure questions (the supply grid), maturity of technologies (EVs and their power sources) and consumer aspirations (mainly price). If one attempts to rank these in the order of necessary appearance, i. e. which of these must be solved first and which are then to follow; the likely vote goes to technology issues. Technologies must still mature to have the right price for EVs so that they provide a viable alternative to consumers. Public innovation policy in terms of research funding for technology developers, be they private or public, is essential. Through public research funding, the scale-up of technological leads is probably swifter. Once this challenge is overcome the demand is likely to boost and create need to develop the infrastructure fast. The latter mentioned will obviously be the next bottleneck.

It is hence the automotive industry that will have to take the necessary first steps, but obviously, government policies that support the development and maturing of these technologies will have a substantial relevance. Tax issues in addition to R&D support are one of the tools for governments. The governments of the countries where the automotive industry is strong have apparently the greatest motivation. In Europe, for example, Germany and France have a clear stake, even though the industries no longer are that tightly connected to particular member states. Globally taken, also US, Japan and South Korea must deal with the issues. Whereas some countries, like Finland, have adopted carbon and emissions based vehicle taxation system, it only brings the purchasing and operating costs of EVs to a more acceptable level, and indeed such policies can have a positive impact on emissions (OECD 2011; OECD 2013). In Finland for

example, the Ministry of Transport and Communications lists climate change mitigation as one of its primary policy targets (Liikenne- ja viestintäministeriö 2013). Electrification of the mobility system obviously is one of the key policy action lines of such strategies. The Finnish tax regime for transport is already based on emissions and carbon footprint, but identified necessary additional measures include road user charges and varying means of favouring of low-emission technologies across the modes. However, deploying carbon based tax system also throughout the production chain could actually pose an additional challenge to EVs' market penetration.

Many energy utilities and grid companies are closely associated with public owners. These have the second largest stake in the new ecosystem. EVs penetration has a profound impact on these companies' cash flow projections, and they must be ready when the time comes for EVs to really enter the mobility market. Supporting their efforts to prepare the infrastructure for EVs could be one successful national and pan-national line of policy. The role of governments to stimulate the development of the charging infrastructure could take many forms: tax incentives, investment grants, etc.

Questions that are more general can be raised regarding the true life cycle sustainability of EVs considering both the energy consumption of the whole ecosystem and evident need to treat the used batteries appropriately. The first question is still somewhat unanswered but the first results from scientific references do not give a straight green light to EV ecosystems. The second question is yet to be solved and a part from technical issues, also financed. If the financing of battery disposal is rolled over to battery manufacturers, which is the first obvious option, the price of EVs (including the batteries) will be slightly higher and slow down the penetration. It might be also here where governments' policies can have an impact.

What is obvious from the literature that EVs in operation will significantly reduce carbon releases of road transport and therefore have a positive contribution to climate change mitigation. The whole ecosystem of EVs and life cycle of ecosystem components could, however, have an opposite effect.

The role of integrators is crucial but in the light of our analysis, it seems that new entrants adopting the integrator role may not be successful unless backed up by key stakeholders, and mainly by the vehicle manufacturers. In order to have some control over the market, the EV man-

ufacturers are likely to pursue this integrator role themselves. The situation might change, however, if manufacturers are able to come up with a model that benefits them all. A jointly owned integrator is one of the obvious answers and it remains to be seen whether EV manufacturers are able to join their efforts to mould the ground of EV business in their favour.

The dynamics between the firms within the ecosystem calls for further analysis. Business model compatibility among ecosystem players is obviously a prerequisite to bring synergies and to pave the way towards a common market platform. Since business models are firm-specific as well as industry-specific, a higher resolution research must be conducted.

Hence, the overall picture remains unclear and it is difficult to see an easy solution to the deadlock of inter-depending challenges. What is clear for certain is that technological development should be supported further in order to remove some of the technical obstacles. The continuum of carbon-reducing policies is equally important, but these must have tangible embodiments affecting the prices of EVs and supply of working infrastructures.

Acknowledgments

Support from VTT Graduate School and EVELINA project financed by the Finnish Technology Agency Tekes are acknowledged. Authors also thank Mr Mikko Tarkiainen and Mr Teppo Kivento from VTT for their support and contribution.

References

- Andersen, P. H., J. A. Mathews, and M. Rask. 2009. 'Integrating Private Transport into Renewable Energy Policy: The Strategy of Creating Intelligent Recharging Grids for Electric Vehicles.' *Energy Policy* 37 (7): 2481–2486.
- Axsen, J., K. S. Kurani and A. Burke. 2010. 'Are Batteries Ready for Plug-in Hybrid Buyers?' *Transport Policy* 17 (3): 173–182.
- Browne, M., J. Allen, and J. Leonardi. 2011. 'Evaluating the Use of an Urban Consolidation Centre and Electric Vehicles in Central London.' *IATSS Research* 35 (1): 1–6.
- Camarinha-Matos, L. M, H. Afsarmanesh, N. Galeano, and A. Molina. 2009. 'Collaborative Networked Organizations – Concepts and Practice in Manufacturing Enterprises.' *Computers & Industrial Engineering* 57 (1): 46–60.
- Camus, C., T. Farias, and J. Esteves. 2011. 'Potential Impacts Assessment of Plug-in Electric Vehicles on the Portuguese Energy Market.' *Energy Policy* 39 (10): 5883–5897.

- Carbone, P. 2009. 'The Emerging Promise of Business EcoSystems.' *Technology Innovation Management Review*, February. <http://timreview.ca/article/227>
- Crist, P. 2012. 'Electric Vehicles Revisited: Costs, Subsidies and Prospects.' Discussion Paper 2012-03, International Transport Forum, Paris.
- Corallo, A. 2007. 'The Business Ecosystem as a Multiple Dynamic Network.' In *The Digital Business Ecosystem*, edited by A. Corallo, G. Pas-siante, and A. Prencipe, 11–32. Cheltenham: Edward Elgar.
- Diamond, D. 2009. 'The Impact of Government Incentives for Hybrid-Electric Vehicles: Evidence from US.' *Energy Policy* 37 (3): 972–83.
- European Commission. 2009. 'Directive 2009/33/EC of the European Parliament and of the Council of 23 April 2009 on the Promotion of Clean and Energy-Efficient Road Transport Vehicles.' *Official Journal of the European Union*, L 120/5.
- Giannoutakis, K. N., and F. Li. 2011. 'Developing Sustainable e-Business Models for Intelligent Transportation Systems (ITS).' In *Building the e-World Ecosystem*, edited by T. Skersys, R. Butleris, L. Nemuraite, and R. Suomi, 200–11. Berlin and Heidelberg: Springer.
- Frigg, R., and S. Hartmann. 2012. 'Models in Science.' In *The Stanford Encyclopedia of Philosophy*, edited by E. N. Zalta. <http://plato.stanford.edu/entries/models-science/>
- Franke, T., and J. F. Krems. 2013. 'What Drives Range Preferences in Electric Vehicle Users?' *Transport Policy* 30:56–62.
- Hearn, G., and C. Pace. 2006. 'Value Creating Ecologies: Understanding Next Generation Business Systems.' *Foresight* 8 (1): 55–65.
- Hidrué, M. K., G. R. Parsons, W. Kempton, and M. P. Gardner. 2011. 'Willingness to Pay for Electric Vehicles and their Attributes.' *Resource and Energy Economics* 33 (3): 686–705.
- Hong, J., Y. Koo, G. Jeong, and J. Lee. 2012. 'Ex-Ante Evaluation of Profitability and Government's Subsidy Policy on Vehicle-to-Grid System.' *Energy Policy* 42:95–104.
- Iansiti, M., and R. Levien. 2004. 'Strategy as Ecology.' *Harvard Business Review* 82 (3): 68–78.
- Jenn, A., I. L. Azevedo, and P. Ferreira. 2013. 'The Impact of Federal Incentives on the Adoption of Hybrid Electric Vehicles in the United States.' *Energy Economics* 40:936–942.
- Kang, J. E., and W. W. Recker. 2009. 'An Activity-Based Assessment of the Potential Impacts of Plug-in Hybrid Electric Vehicles on Energy and Emissions Using 1-day Travel Data.' *Transportation Research Part D: Transport and Environment* 14 (8): 541–556.
- Kley, F., C. Lerch, and D. Dallinger. 2011. 'New Business Models for Electric Cars: A Holistic Approach.' *Energy Policy* 39:3392–3403.

- Koskue, M., and M. Talka. 2010. 'Electric Vehicles.' <http://www.finpro.fi/documents/10304/5e7905ce-e27f-49ba-be1b-c35094d46a38>
- Lieven, T., S. Mühlmeier, S. Henkel, and J. F. Waller. 2011. 'Who will Buy Electric Cars? An Empirical Study in Germany.' *Transportation Research Part D: Transport and Environment* 16 (3): 236–243.
- Liikenne- ja viestintäministeriö. 2013. 'Liikenteen ympäristöstrategia 2013–2020.' <http://www.lvm.fi/julkaisu/4373390/liikenteen-ymparistostrategia-2013-2020>
- Lucas, A., C. A. Silva, and R. C. Neto. 2012. 'Life Cycle Analysis of Energy Supply Infrastructure for Conventional and Electric Vehicles.' *Energy Policy* 41:537–547.
- Lunden, I. 2013. 'A New Place for Better Place, as Bankrupt \$800M+ Backed Electric Car Startup Sold for \$12M.' TechCrunch, 12th July 2013. <http://techcrunch.com/2013/07/12/a-new-place-for-better-place-as-bankrupt-800m-backed-electric-car-startup-sold-for-12m/>
- MEC Intelligence. 2011. 'Drivers and Inhibitors of Electric Vehicles: Based on Data from a Live Test Fleet of Electric Vehicles.' http://e-mobility-nsr.eu/fileadmin/user_upload/downloads/info-pool/MEC_Intelligence_Report_-_Drivers___Inhibitors_of_EVs_Adoption.pdf
- Moore, J. F. 1993. 'Predators and Prey: A New Ecology of Competition.' *Harvard Business Review* 71 (3): 75–86.
- OECD. 2011. 'Environmental Taxation: A Guide for Policy Makers.' <http://www.oecd.org/env/tools-evaluation/48164926.pdf>
- . 2013. 'Climate and Carbon: Aligning Prices and Policies.' OECD Environment Policy Paper 1, OECD, Paris.
- Perujo, A., and B. Ciuffo. 2010. 'The Introduction of Electric Vehicles in the Private Fleet: Potential Impact on the Electric Supply System and on the Environment; A Case Study for the Province of Milan, Italy.' *Energy Policy* 38:4549–4561.
- Petrie, C. 2012. 'Changing the World.' *IEEE Internet Computing* 16 (1): 87–89.
- Ritchey, T. 2002. 'Modelling Complex Socio-Technical Systems Using Morphological Analysis: Adapted from an Address to the Swedish Parliamentary IT Commission, Stockholm, December.' <http://www.swemorpha.com/pdf/it-webart.pdf>
- San Román, T. G., I. Momber, M. R. Abbad, and A. S. Miralles. 2011. 'Regulatory Framework and Business Models for Charging Plug-in Electric Vehicles: Infrastructure, Agents, and Commercial Relationships.' *Energy Policy* 39:6360–6375.
- Schill, W.-P. 2011. 'Electric Vehicles in Imperfect Electricity Markets: The Case of Germany.' *Energy Policy* 39:6178–6189.
- Skippon, S., and M. Garwood. 2011. 'Responses to Battery Electric Vehi-

- cles: UK Consumer Attitudes and Attributions of Symbolic Meaning Following Direct Experience to Reduce Psychological Distance.' *Transportation Research Part D: Transport and Environment* 16 (7): 525–531.
- SmartGridToday. 2013. 'EV Battery Swapping Firm Better Place Goes Bankrupt.' SmartGridToday, 31 May. <http://www.smartgridtoday.com/ext/resources/pdf/sgt/2013/05/SGT130531.pdf>
- Thomas, C. E. 2012. 'How Green are Electric Vehicles?' *International Journal of Hydrogen Energy* 37 (7): 6053–6062.
- Zackrisson, M., L. Avellán, and J. Orlenius. 2010. 'Life Cycle Assessment of Lithium-ion Batteries for Plug-in Hybrid Electric Vehicles: Critical Issues.' *Journal of Cleaner Production* 18 (15): 1519–1529.
- Zhang, Y., Y. Yu, and B. Zou. 2011. 'Analyzing Public Awareness and Acceptance of Alternative Fuel Vehicles in China: The Case of EV.' *Energy Policy* 39:7015–7024.
- Zulkarnain and P. Leviäkangas. 2012. 'The Size, Structure and Characteristics of Finland's ITS Industry.' *Technology & Investment* 3 (3): 158–167.
- Zulkarnain, P. Leviäkangas, M. Tarkiainen, and T. Kivento. 2012. 'Electric Vehicles Market Outlook.' *International Journal of Technology* 3 (2): 156–168.



This paper is published under the terms of the Attribution-NonCommercial-NoDerivatives 4.0 International (CC BY-NC-ND 4.0) License (<http://creativecommons.org/licenses/by-nc-nd/4.0/>).

ARTICLE V

**Business model evolution
for ITS services**

20th ITS World Congress.
14–18 October 2013, Tokyo, Japan.
Copyright 2013 ITS Japan.
Reprinted with permission from the publisher.

Business model evolution for ITS services

Juho Kostiainen

Research Scientist, VTT Technical Research Centre of Finland
Vuorimiehentie 3, Espoo, P.O. Box 1000, FI-02044 VTT, Finland
Tel. +358 40 674 6737, Fax: +358 20 722 7000 E-mail: juho.kostiainen@vtt.fi

Zulkarnain

Research Scientist, VTT Technical Research Centre of Finland
Kaitoväylä 1, Oulu P.O. Box 1100 FI-90571 Oulu, Finland
Tel. +358 20 722 2018, Fax: +358 20 722 2090, E-mail: zulkarnain@vtt.fi

Pekka Leviäkangas

Research Professor, Dept. Industrial Engineering and Management Univ. of Oulu
P.O. Box 4610 FI-90014 University of Oulu
E-mail: pekka.leviakangas@oulu.fi

Raine Hautala

Senior Scientist, VTT Technical Research Centre of Finland
Vuorimiehentie 3, Espoo, P.O. Box 1000, FI-02044 VTT, Finland
Tel. +358 40 584 1114, Fax: +358 20 722 7000, E-mail: raine.hautala@vtt.fi

ABSTRACT

While the global economy has suffered in the recent years and projections for the future are highly uncertain, Intelligent Transport Systems and Services (ITS) is one of the sectors where growth potential is still envisaged and has shown to be growing in steeper curves than other industry sectors. Evaluating the roles and shares of different stakeholders is challenging due to the involvement of several public and private actors, which complicates the business model value network. The roles in value networks change with the emergence of new business models and technology. With concepts such as open data, open source, and cloud computing, the changes can be dramatic. This paper examines existing business models and, based on those, presents both traditional and modern versions of a generalised business model framework.

Keywords: Business model, value network, ITS

1. INTRODUCTION

The global economy has suffered in recent years, and while there are signs of recovery, the projections for the future are also highly uncertain. Intelligent Transport Systems (ITS) is one of the sectors where growth potential is still envisaged despite the gloom overall economic prospects. In Finland, for example, the ITS sector has grown in steeper curves than other industry sectors, including ICT [1]. The global ITS market projections are even more optimistic. Nevertheless, the starting of new investments requires careful evaluation, and new

forms of funding and partnerships are being explored.

Evaluating the roles and shares of different stakeholders in a value chain is challenging. Especially the involvement of several public and private actors complicates the business model value chain, which can be a rather complex, intertwined value network. [2] Some roles in the value networks may change or become obsolete with the emergence of new technologies and business models. The changes, such as prevalence of open data or enabling potential of cloud computing, create opportunities as well as barriers

Providing services to customers can be significantly easier and cheaper with various technologically advanced solutions than by traditional ones, while also saving the costs of maintaining and upgrading physical devices or infrastructure. The replacing role of ITS has long been recognised and it provides real options for infrastructure managers [3]. Some services may, however, be seen as replacements for older solutions that were available free of charge. Even with the added value of new services, the customers' willingness to pay is an issue, creating questions about what is the ultimate source of revenue. While there may be more data available, it still needs to be gathered, stored, processed and transferred – and therefore also paid for – by someone. [2]

New technology and services offer different pricing strategies as well. For example, some ITS services enable pricing based on the behaviour of the driver (e.g. pay-as-you-drive: insurance premiums and charging by miles [4]) or dynamic pricing based on time, place and context (e.g. parking prices based on occupancy level). More accurate and fair pricing methods, such as these, can generate new sources of revenue and alter old ones when applied to different services. Along with more accurate pricing, the ease of mobile payment and flexibility to try out information applications before purchase (e.g. testing an application with advertisements or for a limited time) have potential in attracting new customers.

Device manufacturer markets (e.g. car, teleconference, utilities and entertainment) are converging more and more towards multi-purpose platforms capable of providing flexible information and entertainment. By providing different services, the amount of potential customers is increasing but, at the same time, competitors from different sectors are entering the market. Selling multiple devices to one customer becomes challenging as services overlap. Since software can be updated without replacing hardware, convincing customers to exchange their device for a newer generation version can be difficult. This does, however, present software developers great opportunities for providing their services and applications easily at low costs. Offering software updates, or even hardware upgrades at the server end, can be done with little effort required from the customer, thus sustaining a high level of service

quality and user-friendliness.

When software is based on open source code, the business models may change even more radically. New innovative service concepts and niches can emerge from any direction and they may have entirely new types of revenue logic. For example, ad hoc groups may develop applications and share them on non-profit basis through social media.

2. EXISTING BUSINESS MODELS

Choi et al. [5] identified four different business models for advanced traffic information. The models covered the main functions involved in providing an ITS service – data collection, data fusion, turning data into information and dissemination to end users and other parties. The focus was on the different roles of private companies and public sector.

- **Public-centred Model** has the public sector performing all the functions. Fused information can be provided with no or little charge to the private sector, which can incorporate other data sources to add value to services they offer.
- **Contract-based Mutual System Model** considers the private sector as a participant in the data fusion by a contract between the company and public sector. The processed information can then be equally shared. The private sector may have difficulties monetizing the information and the capital costs for the public sector may be high.
- **Franchise-based Operation** leaves the data fusion entirely to the private sector. Public sector provides data in return for information that should be freely provided to the general public. The technical abilities and resources of the private sector may improve data quality. The company fusing the data can sell it to other companies, while the public sector may become dependent on the monopolistic private sector.
- **Private Sector Competition Model** considers the public sector selling the data to the private sector. In this model, multiple companies can buy data from various sources, resulting in information and services of varying quality. In the long, the most efficient may end up dominating the market.

Burgess et al. [6] have also reviewed a range of business models for real-time traveller information services in the US. There are five typical traveller information business model structures mentioned, i.e. public sector-funded, franchise operations, private-sector operated and funded models, value-added reseller models and business-to-business models. Public sector-funded models here included public-centred operations and contracted operations. So the first three models are relatively similar to the business models presented by Choi et al.

- **Value-added resellers (VARs)** are firms that aggregate and fuse data and resell it. The key component of VAR model is a value-added portion that can take different

forms, e.g. establish relationship with different data providers, merge disparate data sources, or screen a data stream for inaccuracies or outliers. In major markets, all VARs use the same core set of data from the public sector, so the value-added portion of their business differentiates themselves from their competition and warrants the fees they charge for their data.

- **Business-to-business models** exist along the supply chain of traveller information services from data collection to aggregation to dissemination. Examples of such business-to-business arrangements include broadcast traffic reports supported by private data collection, where a traffic information provider contracts with local radio or television stations to be their provider of traffic information; digital map and traffic information in mobile device, Radio Delivery Service-Traffic Message Channel (RDS-TMC) technology for navigation systems, and internet delivery for traveller information.

Furthermore, Lin & Bi [7] proposed a business model for a mobile electronic toll collection application. Figure 1 shows the proposed business model to link banks, credit card services, mobile system providers, toll service providers with general public users.

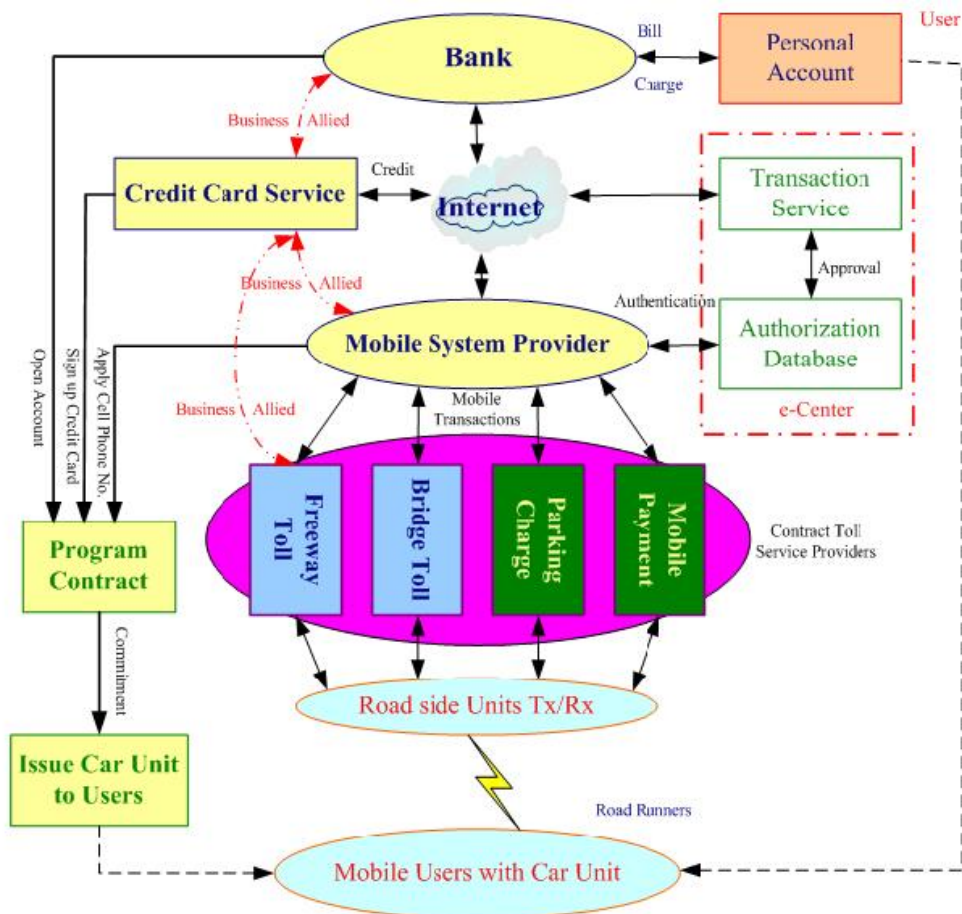

Figure 1. Business model for mobile electronic toll collection [7]

Based on the above business model examples, we present a generalised, traditional business model topology framework for ITS services. According to [1], there are three important, simplistic roles in supplying ITS products and services. First, the role of equipment and hardware providers that supply infrastructure or vehicle associated physical components or personal devices. Second group consists of system and application providers who supply entire, or sub-sets of, ITS systems which combine and integrate the products and services of system and application providers, sometimes including the services of the last group of suppliers, the service suppliers. The last mentioned category of the supply side provides consultancy, design, installing, and operating ITS services. The additional actor considered in this research is a data provider that has the role of production and maintenance of the data as sources for the next chain in ITS value chain. These supply function groups meet the demands coming from the public, corporate customers, and consumers.

Figure 2 presents the generalised business model for ITS services, involving each actor in ITS services ecosystem. As shown in Figure 2, data provider provides data to content provider for producing content to be disseminated to system & application provider. Some contents produced by content provider will be subsequently processed in usable format, and forwarded to the service provider as an application or software. Customers get the services from the service provider as they buy the device from equipment and hardware provider.

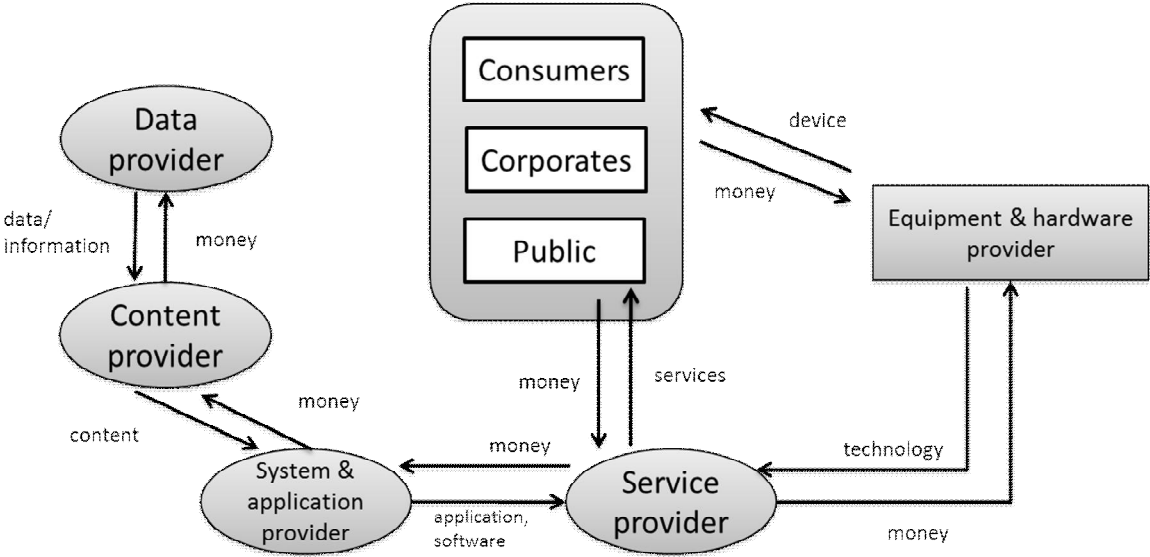

Figure 2. Generalised, traditional business model for ITS services. (© authors)

3. GENERALISED BUSINESS MODEL AND ECOSYSTEM TOPOLOGIES

Business models evolve in every firm, for adjusting to a dynamic environment. There are three main external drivers of business model evolution, i.e. dynamics of technology, market, and regulation. All these drivers have different roles in each phase of maturity of the business. Technology takes the dominant role of business model evolution in early phase of a new business, while regulation takes its role in the implementation phase and the market driver, without a doubt, guides established market business the most. [8] As for today's ITS business models, technological advances and market competition are taking more active roles. Recent development in various kinds of technologies, e.g. wireless technologies, internet, and mobile devices, has made the evolution of ITS business models a necessity. From the market perspective, competition among ITS companies and the existence of substitutive products for the same services demand business models to evolve. As a regulatory aspect, issues of data ownership and data quality are some examples.

Processing data into a meaningful format is obviously an important part in any information service. Traditionally, the processing would be done by software installed on a device. However, today with practically always available internet access, the processing can be outsourced as well to a cloud computing service. The revenue structures of these services are significantly different. While the traditional solution pretty much consists of one purchased copy of the software per user, the pricing of the use of outsourced software can much more flexible (e.g. pay per use or subscription). The cloud computing business model itself comprises different layers (infrastructure, platform and software), which can be implemented by one or more actors. Infrastructure as a Service (IaaS): utilizing infrastructure efficiently and providing a data centre. Platform as a Service (PaaS): providing a layer over the infrastructure for handling lower level tasks. Software as a Service (SaaS): the ability to use dedicated, specialised data processing software online. SaaS suits ITS applications that require intense data analysis but do not require computation to happen absolutely real-time (e.g. crash prevention). [9]

A solution with interoperability between service providers or across borders can be very user-friendly by providing the same services in different situations with little effort required from the customer. A business model where customer level service providers work via a higher level operator can provide interoperability and support between the different services. For example, the European Electronic Toll Service (EETS) is planned using this business model – the toll chargers work via the toll service provider, meaning the systems are compatible and the user need not subscribe to different services or devices. [10]

Based on these recent business models, we present a description of a modern business model for ITS services in Figure 3. The blue layers in the figure illustrate the different roles that need to be filled in order to deliver an ITS service, or any other kind of information-based service. While a single company can perform all the functions by itself, focusing on a single layer, or core competence, can be more cost effective by outsourcing the other functions. In addition, it can also enable expanding to other markets by adjusting the strategic focus and using resources more effectively.

Instead of providing specialized services, a business can specialize on providing services. For example, from a service provider's point of view, it can be very similar to create end user services for traffic status and weather conditions based on information provided by content providers, even though the data gathering and processing are completely different. Even further, for a company developing ICT platforms, the requirements for ITS services may have similarities to completely different sectors, such as library services. This means that a focusing on certain operations may open new market opportunities for low marginal costs as little investments or training are needed.

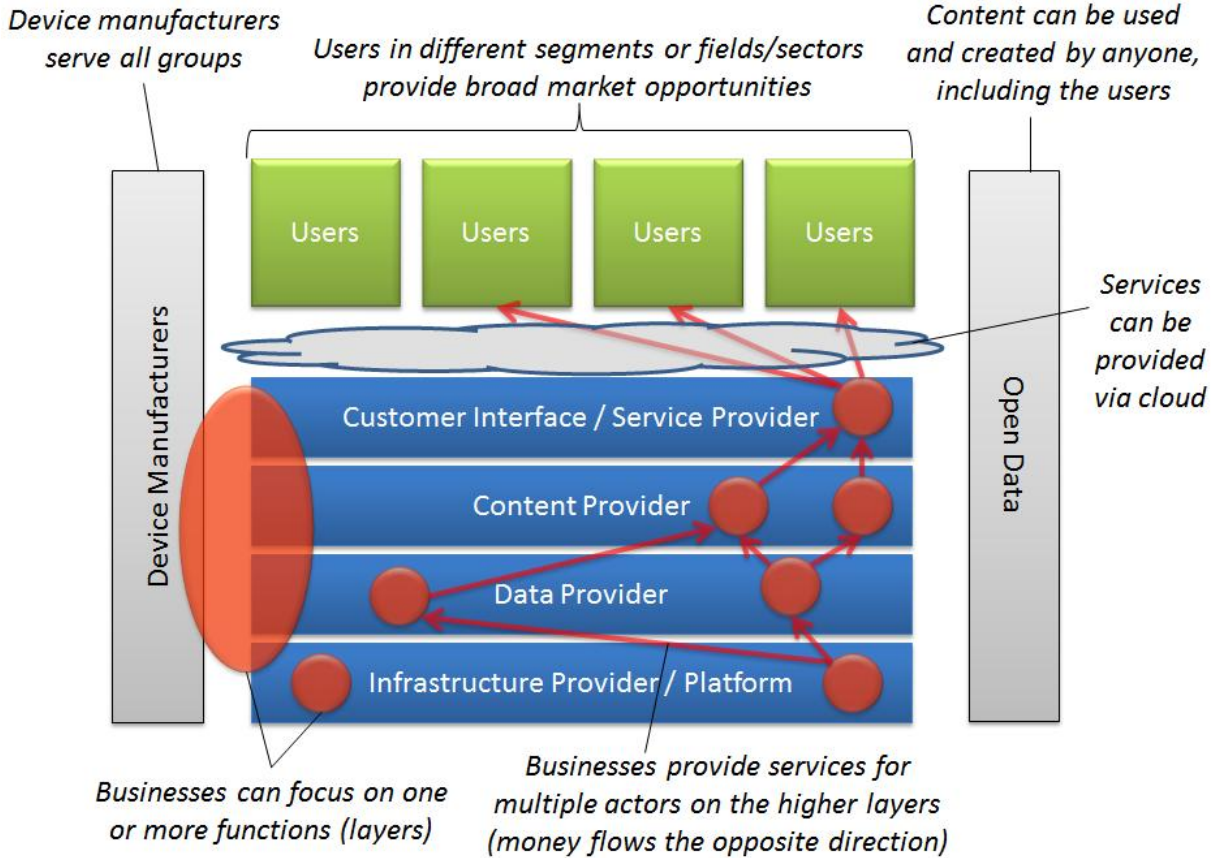

Figure 3. Modern business model for ITS services. (© authors)

Larger companies can take on many of the functions themselves. Device manufacturers are in

an important role creating the platforms for which services are developed for. Therefore they also have the power to limit the systems according to their own strategy and taking part in the service creation and provision. Service ecosystems, such as application stores, are a way for large companies to insert themselves between the service creators and users. Such systems can create efficient market places where services can be easily introduced and delivered but they can also seem limiting by being committed to a single brand of devices.

New data sources can also change business models significantly. By nature, ITS services are often related to the user's position, which changes constantly. In recent years, the availability and affordability of mobile devices with accurate positioning and constant internet access have enabled the provision of personalized, context aware services in real-time. Mobile device users are both a huge consumer markets of new, innovative services as well as producers of new data, which service providers can use to improve or create new services.

In addition to receiving data from users and other sources, for some service providers, benefits can be found from doing the opposite – handing out their own data openly for free. For example, public transport authorities can improve the attractiveness of their transport services by providing their timetable and route information as open data for the public to create information services. This means they can have better services with smaller investments by providing the tools for external developers to create and improve the services.

4. DISCUSSION

On the one hand, businesses are becoming more focused into certain core areas instead of providing complete systems from ground up, but on the other hand, large ecosystems that provide the devices, tools and marketing channels have a significant role in today's service business as well. The ecosystem providers get committed customers by tying the services to their own equipment. For service providers, these systems offer an easy way to reach a huge customer base with little investments in creating and publishing the service applications.

The limiting factor of such service ecosystems built around certain brands is that the services would need to be separately created for other device brands. This can result in extra efforts in having to do the same work for different platforms in order to reach more potential customers committed to other brands. New market segments and larger customer bases can be reached with relatively small marginal costs. Larger audience may be necessary for transport intelligent transport services to be effective and sustainable. As more and more services are available, the customers' willingness to pay is an issue.

The future form of service business models may transform into more open and flexible ecosystems that would enable services to be created with less platform and brand limitations. A European Commission's 7th framework programme project MOBiNET is one attempt at developing such open multi-vendor platform for Europe-wide mobility services. The key of the project is to address the barriers of deploying cooperative services across proprietary technologies in user devices. MOBiNET will serve both B2B and B2C (as well as B2B2C) businesses and customers. The project develops a comprehensive directory, market place and tools for providing and developing mobility related services that can be used Europe-wide, platform-independently.

5. REFERENCES

- [1] Zulkarnain & Leviäkangas, P.: **The size, structure and characteristics of Finland's ITS industry.** *Technology & Investment*, Volume 03, Number 03 (August 2012), pp. 158–167. Scientific Research Publishing.
- [2] Leviäkangas, P.: **Building Value in ITS Services by Analysing Information Service Supply Chains and Value Attributes.** *International Journal of Intelligent Transport Systems Research*. Volume 9, Number 2, pp. 47–54, May 2011.
- [3] Leviäkangas, P. & Lähesmaa, J.: **Profitability Evaluation of Intelligent Transport System Investments.** *ASCE Journal of Transportation Engineering*. May/June 2002, Volume 128, Number 3.
- [4] Zantema, J., van Amelsfort, D.H., Bliemer, M.C.J. & Bovy, P.H.L.: **Pay-as-You-Drive Strategies: Case Study of Safety and Accessibility Effects.** *Transportation Research Record: Journal of the Transportation Research Board*, Volume 2078 / 2008, pp. 8–16.
- [5] Choi, K., Lee, C. & Son, Y.: **Traffic information and Some Business Models.** *KSCE Journal of Civil Engineering*, June 2001, Volume 5, Issue 2, pp. 113–122.
- [6] Burgess, L., Toppen, A., & Pretorius, P.: **Real-time Traveler Information Services Business Models: State of the Practice Review**, FHWA-HOP-07-115, May 2007, Federal Highway Administration.
- [7] Lin, C. E. & Bi, L. Y.: **A Mobile Electronic Toll Collection fo E-Commerce Applications.** *Journal of Theoretical and Applied Electronic Commerce Research*, August 2008, Volume 3, Issue 2, pp. 111–128.
- [8] Bouwman, H., MacInnes, I.: **Dynamic Business Model Framework for Value Webs**, Proceedings of the 39th Hawaii International Conference on System Sciences, 2006.
- [9] Dorfman, M.: **Software as a Service and the growth of ITS.** *Proceedings of 19th ITS World Congress*. Vienna, Austria, 22–26 October 2012.
- [10] Rousselin, P.: **Interoperability: the Hub solution.** *Proceedings of the 19th ITS World Congress*. Vienna, Austria, 22–26 October 2012.

Title	Exploring the transport system under technological change – market, business ecosystem and business model viewpoints
Author(s)	Zulkarnain
Abstract	<p>Transport systems are continuously evolving. A modern transport system needs to be sustainable socially, economically and environmentally. In recent decades, technological development, especially in information and communication technology, has affected today's transport systems. Three different cases are explored in this dissertation: intelligent transport systems in general, electro-mobility systems, and road weather and maintenance systems. Intelligent transport systems encompass a broad range of information and communication technologies that improve the safety, efficiency and performance of the transportation system. In addition to intelligent transport systems, electric vehicle systems have emerged because of increasing environmental concerns as well as oil depletion issues. Furthermore, the road weather and maintenance system is an interesting case especially in latitudes with severe weather. Despite vast amounts of recent research on the aforementioned topics, most previous studies have focused on the technical side, such as developing, prototyping and testing the technologies, whereas only a few studies have focused on the business aspects. Therefore, this dissertation aims to enrich the analysis of the emerging transportation sector under technological change from the business perspective and to provide new insights for future research. The purpose of this study is to explore the emerging transportation sector from several viewpoints by conducting empirical case studies. The cases covered are analysed through the perspectives of markets, business ecosystems and business models. The geographical scope of the research is mainly limited to Finland, especially its intelligent transport systems and road weather maintenance infrastructure. The global perspective is adopted in the case of electric vehicles. The nature of this research is qualitative, and inductive reasoning is applied. The research examines the characteristics of the market, business ecosystem, and business models that emerge transport systems under technological change. Furthermore, based on the findings of the case studies, a holistic framework model is developed to understand the technological system by integrating the viewpoints of markets, business ecosystems and business models</p>
ISBN, ISSN, URN	ISBN 978-951-38-8471-0 (Soft back ed.) ISBN 978-951-38-8470-3 (URL: http://www.vttresearch.com/impact/publications) ISSN-L 2242-119X ISSN 2242-119X (Print) ISSN 2242-1203 (Online) http://urn.fi/URN:ISBN:978-951-38-8470-3
Date	October 2016
Language	English
Pages	98 p. + app. 85 p.
Name of the project	
Commissioned by	
Keywords	intelligent transport systems, electric vehicles, road weather and maintenance, market, business ecosystem, business model, exploratory, technological change
Publisher	VTT Technical Research Centre of Finland Ltd P.O. Box 1000, FI-02044 VTT, Finland, Tel. 020 722 111

Exploring the transport system under technological change – market, business ecosystem and business model viewpoints

In recent decades, technological development, especially in information and communication technology, has affected today's transport systems. Three different cases are explored in this dissertation: intelligent transport systems in general, electro-mobility systems, and road weather and maintenance systems. Despite vast amounts of recent research on the aforementioned topics, most previous studies have focused on the technical side, such as developing, prototyping and testing the technologies, whereas only a few studies have focused on the business aspects.

Therefore, this dissertation aims to enrich the analysis of the emerging transportation sector under technological change from the business perspective and to provide new insights for future research. The purpose of this study is to explore the emerging transportation sector from several viewpoints by conducting empirical case studies. The cases covered are analysed through the perspectives of markets, business ecosystems and business models. The geographical scope of the research is mainly limited to Finland, especially its intelligent transport systems and road weather maintenance infrastructure. The global perspective is adopted in the case of electric vehicles. The nature of this research is qualitative, and inductive reasoning is applied.

The research examines the characteristics of the market, business ecosystem, and business models that emerge transport systems under technological change. Furthermore, based on the findings of the case studies, a holistic framework model is developed to understand the technological system by integrating the viewpoints of markets, business ecosystems and business models.

ISBN 978-951-38-8471-0 (Soft back ed.)
ISBN 978-951-38-8470-3 (URL: <http://www.vttresearch.com/impact/publications>)
ISSN-L 2242-119X
ISSN 2242-119X (Print)
ISSN 2242-1203 (Online)
<http://urn.fi/URN:ISBN:978-951-38-8470-3>

