



# EcoNBC feasibility study

Transforming New Borg El Arab into an EcoCity



# **EcoNBC feasibility study**

## **Transforming New Borg El Arab into an EcoCity**

---

Carmen Antuña Rozado, Åsa Hedman, Pekka Tuominen,  
Francesco Reda

VTT Technical Research Centre of Finland Ltd.

Yehia ElMaghary, Ahmed ElShazly, Mona GamalEldin, Ali  
Kamel, Abdelazim Negm, Ahmed Tawfik, Heba Saeed

Ahmed AbdelMonteleb, Mohamed Ayeldeen, Waled  
Dawoud, Bahaa Elboshy, Ghada Elshafei

E-JUST Egypt-Japan University of Science and Technology

Mohamed Shahin

Alexandria University

Ahmed Yousry

Cairo University



ISBN 978-951-38-8301-0 (URL: <http://www.vttresearch.com/impact/publications>)

VTT Technology 220

ISSN-L 2242-1211

ISSN 2242-122X (Online)

Copyright © VTT 2015

JULKAISIJA – UTGIVARE – PUBLISHER

Teknologian tutkimuskeskus VTT Oy

PL 1000 (Tekniikantie 4 A, Espoo)

02044 VTT

Puh. 020 722 111, faksi 020 722 7001

Teknologiska forskningscentralen VTT Ab

PB 1000 (Teknikvägen 4 A, Esbo)

FI-02044 VTT

Tfn +358 20 722 111, telefax +358 20 722 7001

VTT Technical Research Centre of Finland Ltd

P.O. Box 1000 (Tekniikantie 4 A, Espoo)

FI-02044 VTT, Finland

Tel. +358 20 722 111, fax +358 20 722 7001

# Contents

- 1 Executive summary .....5
- 2 Introduction .....6
- 3 Background.....7
  - 3.1 Who is EcoNBC FS meant for?.....7
  - 3.2 Summary of the current situation .....9
    - 3.2.1 City planning .....9
    - 3.2.2 Energy .....11
    - 3.2.3 Water .....13
    - 3.2.4 Waste.....13
      - Domestic and industrial waste water .....13
      - Solid waste management .....14
    - 3.2.5 Transport .....14
      - Existing road network .....14
      - Existing public transport system.....14
      - Existing pedestrian and bicycle transport.....14
      - Railway line and stations in NBC.....15
      - Borg el Arab International Airport .....15
  - 3.3 Stakeholders involved.....15
- 4 Scope .....16
  - 4.1 Sectors considered .....16
    - 4.1.1 Residential .....16
    - 4.1.2 Commercial/Public facilities .....17
    - 4.1.3 Industrial.....18
    - 4.1.4 Services/Utilities .....19
    - 4.1.5 Transport .....22
- 5 Vision .....25
  - 5.1 General overview .....26
    - 5.1.1 Energy .....26
    - 5.1.2 Water .....26
    - 5.1.3 Waste.....26
    - 5.1.4 Other independent issues.....27
  - 5.2 Vision and targets per sector .....27
    - 5.2.1 Residential .....27
    - 5.2.2 Commercial/Public facilities .....28
    - 5.2.3 Industrial.....29
    - 5.2.4 Services/Utilities .....30
    - 5.2.5 Transport .....30
- 6 Scenarios .....31
  - 6.1 General scenarios .....31

6.1.1	BAU scenario .....	32
6.1.2	LIS scenario .....	32
6.1.3	HIS scenario .....	33
6.2	Scenarios per sector .....	34
6.2.1	Residential sector .....	34
6.2.2	Transport sector .....	39
7	Impacts .....	43
7.1	Residential sector .....	43
7.1.1	Energy and CO <sub>2</sub> emissions .....	43
7.1.2	Cost effectiveness analysis .....	45
7.1.3	Social impact analysis .....	47
7.2	Transport sector .....	48
7.2.1	Evaluation process for projecting the transportation energy consumption and emissions under different policies .....	48
7.2.2	Transport Forecast Models .....	49
7.2.3	Energy/Emission Rates in NBC .....	50
7.2.4	The Computer System “TraEco” .....	53
7.2.5	Evaluation of Scenarios .....	54
7.2.6	Cost analysis .....	57
8	Engagement of stakeholders .....	63
8.1	Challenges and opportunities of eco-cities from investors point of view .....	63
8.1.1	Challenges .....	64
8.1.2	Opportunities .....	66
9	Pioneering examples .....	68
9.1	Textile industry case study .....	68
9.1.1	Introduction .....	68
9.1.2	Material and Methods .....	68
9.1.3	Results and discussion .....	68
9.2	Paper industry case study .....	71
9.2.1	Introduction .....	71
9.2.2	Material and methods .....	71
9.2.3	Results and discussion .....	72
9.3	International examples .....	73
9.3.1	Freiburg, Germany .....	74
9.3.2	Vancouver, Canada .....	75
9.3.3	Viikki, Finland .....	77
10	Benefits and barriers .....	78
11	References .....	80

Annex 1 and 2  
Abstract

## 1 Executive summary

New Borg El Arab was inaugurated in 1988 and is seen as the natural extension of Alexandria, as well as one of the most important industrial areas in Egypt. Transforming New Borg El Arab City into an EcoCity was one of the main drivers for EcoNBC project (EcoCity Capacity Building in New Borg El Arab City). Carrying out a Feasibility Study to explore more in detail the viability of the idea was one of the first steps to be taken towards that transformation. In this case, it is the result of the joint effort of a team of Finnish and Egyptian experts through a series of structured workshops that took place both in Finland and Egypt, and a number of focused discussions that involved also key stakeholders.

An insight into the different economic sectors has been taken and a vision of how the main issues of concern selected, namely Energy, Water and Water, should be approached from each of those sectors has been defined, of course with a special emphasis on the sustainability of the Ecosystem. This has allowed the expert team responsible for this Feasibility Study to propose practical solutions in the form of scenarios. In the case of some sectors where reliable data was available for the calculations, these scenarios have been developed down to their associated impacts.

In consequence, by providing a more grounded understanding of the present situation and the opportunities for the future, this Feasibility Study can be useful for decision makers and planners, but also for investors, funding organizations and donors.

## 2 Introduction

This Feasibility Study (FS) is one of the outcomes of EcoNBC, EcoCity Capacity Building in New Borg El Arab City (NBC), project funded by the Institutional Cooperation Instrument (ICI) under the Ministry for Foreign Affairs of Finland. It was carried out by a team of experts from VTT Technical Research Centre of Finland Ltd and Egypt-Japan University of Science and Technology (E-JUST), and its main objective is to evaluate in as much detail as possible the idea of turning New Borg El Arab (NBC) into an EcoCity.

It is generally accepted that a FS should help to identify: a) if the idea is viable or not; b) useful facts and figures to aid decision-making; and c) alternative approaches and solutions for putting the idea into practice. The first discussions among the experts involved were aimed at defining the framework for the development of FS intended as shown in Figures 1 and 2, as well as to establish the Table of Content (see pages 3 and 4) and the most suitable methodology for developing the agreed content. In addition to the previous, a time horizon of 20 years was established for EcoNBC FS.

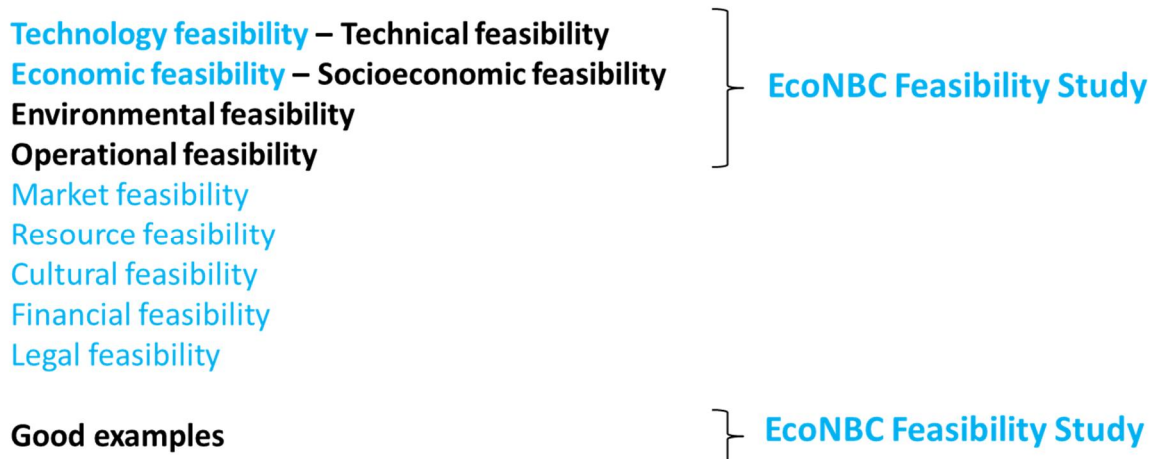

Figure 1. Main components agreed for EcoNBC FS. (Carmen Antuña, VTT)

It was decided that the Table of Content of the EcoNBC FS should include the Scope of the study, the Vision of NBC as an EcoCity, the possible sustainability Scenarios and the Impacts of the proposed Scenarios. The measurements and calculations associated to the Impacts become particularly important to assess and validate the viability of the Scenarios defined.

To complete the FS and to illustrate what can be achieved in practice, it seemed necessary to show some pioneering examples from NBC and also from abroad. The examples selected from NBC correspond to some of the main industries: textile and paper. Their inclusion in this FS aims at highlighting the already existing local initiatives towards a more sustainable industry, which might hopefully inspire other industries to follow the example.

## Turning New Borg El Arab into an ECOCITY

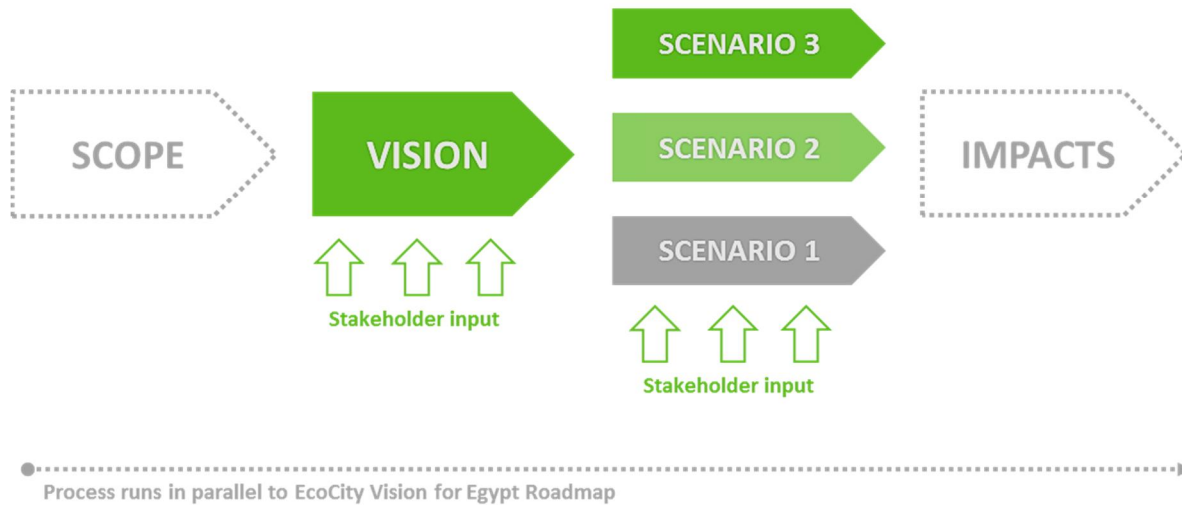

Figure 2. FS development process. (Carmen Antuña, VTT)

The background to this FS is also provided together with a reflection on the benefits and barriers of undertaking a FS to transfer NBC into an EcoCity.

One of the biggest challenges encountered has been the unavailability of necessary data or the lack of reliability of the data available. Therefore a number of decisions have been made in order to overcome this situation, which will be explained more in detail in the corresponding chapters.

From the beginning and for the sake of consistency, it was also seen as necessary to align the content and methodology of the FS with the EcoCity Roadmap for Egypt (<http://www.vtt.fi/inf/pdf/technology/2015/T215.pdf>), another of EcoNBC project's main outcomes, aiming at developing an EcoCity Vision for Egypt. Therefore, both tasks have been carried out in parallel.

### 3 Background

#### 3.1 Who is EcoNBC FS meant for?

NBC was inaugurated in November 1988 and is currently one of the major residential and industrial zones in Alexandria. NBC is seen as the natural extension of Alexandria City. It was constructed, as many other new cities, for absorbing the current and future population, providing more work opportunities for youth and decreasing desertification. It is regarded as the most important industrial zone in Egypt, covering an area of more than 2000 hectares and comprising about 1700 industrial facilities and institutions that provide the investors and owners of all small and medium projects with needed facilities and services.



With NBC being the home city of E-JUST, E-JUST got the idea and the ambitious goal of transferring NBC into the first EcoCity in Egypt for several reasons:

- it is a new city with expanding potentials and the expansion plans of NBC are currently under consideration,
- it is an industrial city with vast land capacity that exists around the industrial area, its infrastructure is fairly new and could be readily upgraded if needed,
- it has a Centre of Action, viz., the newly established E-JUST, in addition to the existing City of Scientific and Technical Research (CSTR), E-JUST has land which could be used for production of Green Energy as Wind, Solar and bio fuel (e.g., plantation and production of jojoba or palm oil),
- the EcoCity of NBC will offer endless Research Topics in most of the fields of E-JUST and numerous joint research topics with Research Institutes as VTT and finally
- other cities in Egypt can take examples from NBC.

The first step to be taken in order to transfer a city into an EcoCity is to undertake a Feasibility Study (FS). The FS undertaken for NBC consists mainly of an insight into the different economic sectors as residential, commercial, industrial, services and transport, and a vision of how the main issues of concern as Energy, Water and Waste Management should be approached modified and/or improved putting great emphasis on the sustainability of our Ecosystem. In other words, it would describe a few practical alternatives on how to decrease the pollution at NBC as far as practically possible, through minimizing the consumption of natural resources and depending mainly on renewable resources. Hand in hand with this approach, an effective and comprehensive program for raising the awareness of the inhabitants of NBC, particularly the new generations should be given. Training courses for school teachers and NGO's members would be arranged, in addition to Workshops, informative meetings and prizes to school children.

Accordingly, the suggested solutions presented in the FS will in the first place be important to decision makers and planners, who are concerned with improving the eco-social and environmental conditions, particularly those of NBC, which is the target of this study and generally of other Egyptian cities. The FS and the alternatives it contains will be also of particular interest to researchers, engineers and scientists who could investigate them thoroughly and pursue the ideas they contain. In addition, the FS will be of considerable importance for the society of NBC as a whole, and even for the Egyptian society, since it is intended to be an example that other cities in the country could follow.

On the other hand, the FS is essentially meant for Investors, Funding Organizations and Donors, who will be in a position to go through these alternatives and select from them

the solutions, which in their opinion are most relevant and applicable, taking into account the eco-social and environmental aspects.

### 3.2 Summary of the current situation

#### 3.2.1 City planning

New Borg El Arab City has major development plans underway and the city is expected to grow substantially in the future, multiplying the current population many times over. The current Strategic Master Plan for New Borg El Arab City was approved in 2013 by the New Urban Communities Authority (NUCA) and the General Organization for Physical Planning (GOPP) and is presented in Figure 3. It shows the existing and proposed land uses for the city until the year 2032. The current population is approximately 100 000 inhabitants, which is expected to grow to 750 000 inhabitants by 2032.

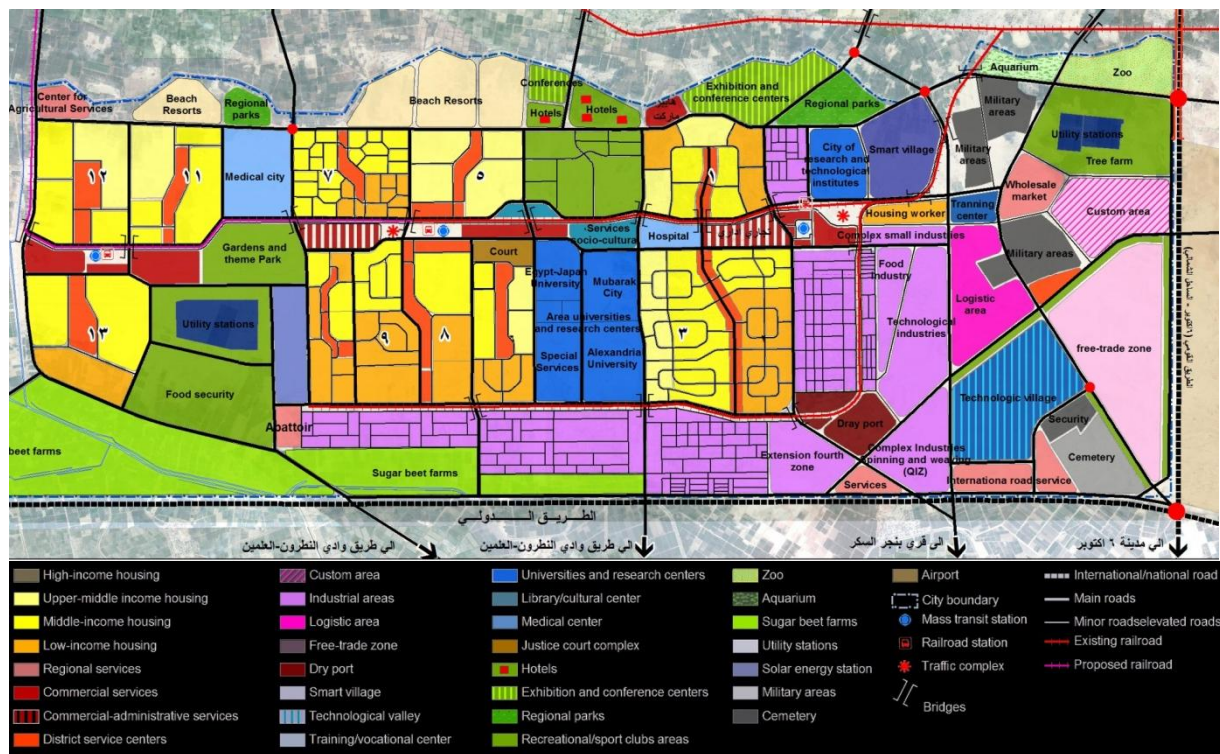

Figure 3. Approved Strategic Master Plan of New Borg El-Arab City for 2032. (Mahmoud Yousry and Associates in cooperation with AECOM, 2013)

Generally, the city is subdivided into distinct separated main areas, namely: the residential area (including city, district and neighbourhood service facilities and amenities), the industrial areas east and south of it, and four regional facilities areas, two of which are located north and east of the residential areas, as well as two regional areas separating the residential sectors.

The residential area of the city is composed of three sectors separated from each other by regional facilities areas. Each sector has its own service facilities area including commercial, administrative, health, educational, religious, cultural and recreational amenities. The centre of each of these sectors is accessible by a railroad and mass transit stations. Residential areas are hierarchically subdivided into 4 residential sectors and 13 residential districts as follows:

- First Residential Sector: including the first three districts of the city, which are the most completed, with functioning service facilities at city, district and neighbourhood levels. This sector is separated from the Second and Third Districts by a regional services area which include social and sports clubs, and the universities and research institutions area.
- Residential Sectors Two and Three: including Districts from 3 to 10. The main roads and basic infrastructure has been implemented in these sectors. Residential and services projects are progressing in these districts, in particular, districts 3, 7, 9 and 10. These sectors are separated from Sector Four by another regional services area which include allocations for future uses as the medical city, recreational and amusement parks, and an agricultural production area for the city.
- Residential Sector 4: includes Districts 11, 12 and 13. These are new districts that have been added to the original master plan of the city to accommodate the future expected population which will be generated in response of the new proposed industrial and regional service facilities.

Residential areas are about 830 *feddans* (a unit of area used in Egypt equivalent to 0.42 hectares) and will accommodate 750,000 inhabitants by 2032. In general, northern districts of the city are designated for high-end and upper middle housing categories, while middle and low-income housing are located in the southern districts and adjacent to industrial areas. To date, only about 40% of the land allocated for residential use has been developed or designated for development.

Existing industrial areas of the city are located in 5 zones east and south of the residential districts, and are about 2,100 *feddans* in area. Currently there are about 700 industrial establishments, employing about 45,000 workers. The industrial zones comprise a wide range of industries. To date, about 40% of the land in the existing industrial zones has not been designated yet.

The strategic master plan has yet proposed a number of future industrial areas in the eastern expansion area of the city. These include a textile industry complex, an agro-industrial area, technological industries zone, a small-scale industries area, in addition to logistic and inventory services such as a dry port, warehouses, a customs area, vocational center, and wholesale market. In addition, a smart village and a free specialized industrial/commercial zone have also been proposed in the eastern

expansion area, as it is at the crossroads of the Borg Al Arab international airport east of the city and the international road south of it.

The northern area of the new master plan (between the residential sectors and the city's northern boundary) is totally designated for future regional service facilities. Proposed uses are a hotels area, a hypermarket, regional parks, exhibitions grounds, and high-end residential gated communities.

### 3.2.2 Energy

What follows is an energy overview for the whole Egypt, which to a large extent is also applicable to NBC. In Section 6.1.1 Energy and CO<sub>2</sub> emissions, where the impacts of the scenarios proposed for the Residential sector are analysed, a more detailed description of the energy demand and the citizens' behaviour is provided.

#### Oil and gas

According to the Oil and Gas Journal's 2012 estimate (Oil and Gas Journal, 2012), Egypt's proven oil reserves are 4.4 billion barrels, an increase from 2010 reserve estimates of 3.7 billion barrels. After Egypt's production peak of over 900,000 bbl/d in the 1990s, output began to increasingly decline as oil fields matured. However, ongoing successful exploration has led to new production from smaller fields and enhanced oil recovery techniques in existing fields have eased the decline at aging fields. In addition, output of Natural Gas Liquids (NGLs) and lease condensate have increased as a result of expanding natural gas production and have offset some of the other declines in liquids production (EIA, 2013). One of Egypt's challenges is to satisfy increasing domestic demand for oil in the midst of falling domestic production.

Production of gas nearly tripled between 1998 and 2010. In 2010, Egypt produced roughly 63 billion cubic meters (bcm), exported 18 bcm and consumed 45 bcm (Razavi, 2012). The electricity sector is the dominant gas consumer, accounting for 57% of the total gas demand. The industrial sector consumes about 11% of total gas consumption while fertilizer and cement industries are also large consumers, accounting for 10% and 8% respectively. The petroleum sector uses a substantial amount of gas for its own use and re-injection, accounting for 5% of total gas consumption.

Gas is delivered to the residential sector through low-pressure pipeline distribution systems and in Liquefied Petroleum Gas (LPG) cylinders supplied by retailers. Combined, they account for 2% of the total gas demand, but expected to grow at a fast pace (about 15% p.a.). Finally, the use of Compressed Natural Gas (CNG) in vehicles accounts for about 2% of total gas consumption; all taxis in Cairo area must now run on CNG.

## Hydro energy

Most of the available hydropower energy resources in Egypt are mainly located on the River Nile. They were largely exploited with the construction of the Aswan Reservoir, the High Dam and the Esna Barrage Hydropower Station, with installed capacity of 592 MW, 2100 MW and 91 MW respectively and representing a total installed capacities of 2783 MW. There are 109 MW hydropower projects at Nagah Hamady and Assiut Barrages under construction on the main river. Small capacities of another 60 MW in total are also available at main canals and branches of the river. These capacities which sum up to a grand total of 2952 MW represent most of the available potential.

## Wind energy

Among other renewable energy resources, wind energy offers significant opportunities. Egypt is endowed with an abundance of wind energy resources especially in the Suez Gulf area which is considered one of the best sites in the world due to high and stable wind speeds. The West of Suez Gulf Zone offers the most promising sites to construct large wind farms due to high wind speeds which range between 8–10 m/s on average and also due to the availability of large uninhabited desert area. There are also other promising sites having wind speed of 7–8 m/s in the east and west of Nile River near the cities of Beni Sweif and Menia Governorates and El-Kharga Oasis in New Valley Governorate. Egypt's progress in implementing wind power projects is rather impressive in the sense that the installed capacity is the largest in Africa and in the Middle East.

## Solar energy

Egypt is one of the sun-belt countries enjoying one of the largest potentials of solar energy. The Solar Atlas issued in 1991 shows that the average direct normal solar radiation is 2000–3200 kWh/m<sup>2</sup>/year. The sunshine duration ranges between 9–11 h per day from North to South with very few cloudy days (UNEP, 2008).

## Biomass energy

The potential for biomass energy can be classified as agricultural residue, animal by-products, municipal solid waste and sewage sludge. Organic matter is typically the main constituent, accounting for up to 60% of solid waste in Egypt, which is above the typical values in most countries and indicates its great value as a bio-fuel source. The amounts of Municipal Solid Waste (MSW) produced in Egypt are estimated to be more than 20 million tons/year, with the poorer cities generating the least. Power generation from gasification of sewage sludge in waste water treatment plants is already being used (for example, the El-Gabal El-Asfer 23 MW plant), with a potential generation of 1,000 MW from agricultural waste.

As an example of energy profile from NBC, an average residential building can be 4 storeys high, and a typical apartment can be around 114 m<sup>2</sup>. The building has a lightweight envelope consisting of a double-brick wall with an air gap but without thermal insulation, non-ventilated roof and poor indoor air quality. The energy system consists of a storage hot water tank and a heat pump. Considering also the technologies described more in detail in Section 6.1.2, the annual final district energy demand of the heating and cooling systems for the residential sector in NBC would be around 620 GWh. The final district energy balance, which includes the appliances' energy consumption, would be around 846 GWh, whereas the CO<sub>2</sub> emissions produced would amount to 394 K tons.

### 3.2.3 Water

The city has a water treatment plant with a capacity of 166 000 m<sup>3</sup>/day. The treatment is composed of a pre-chlorination step followed by a coagulation process using alum ending in a sand filtration unit. The intake of the water treatment plant is mainly from the Mariout canal. If the intake is not enough, extra intake from Nubariya canal is frequently used. The quality of the potable water of the city does not comply with World Health Organization (WHO) and Egyptian standards (ministerial decree, 2006) for human use. The population of the city normally uses onsite membrane filtration for further purification of the water. This is mainly because the intake of the water treatment plant is polluted from different sources such as industrial, domestic and agricultural wastewater. Therefore, pollution control and prevention of the intake of water is required to improve the efficiency of water treatment plant.

### 3.2.4 Waste

#### Domestic and industrial waste water

A sewage system of 562 km length has been established together with a sewage treatment plant (oxidization plant only) with of 36,000 m<sup>3</sup> capacity. The industrial wastewater is facing some problems because of lubricants and factory wastes dumped in sewage and the availability of the final treatment unit. Some industries in New Borg El Arab partially treat or recycle generated industrial wastewater in compliance with Egyptian standards (Ministerial Decree no 44 for year 1994). Others, however, continue to heavily pollute water resources.

Unfortunately, there is no data for either industrial solid waste or for wastewater. However, the mixture of domestic sewage and industrial wastewater is currently treated at a waste stabilization pond with a capacity of 40,000 m<sup>3</sup>/d and the plant effluents are used for irrigation of the forest. The treatment plant consists of 2 ponds. Each pond comprises 9 facultative ponds, arranged in 3 parallel series.

## Solid waste management

The organic fraction of MSW is mainly used for composting. MSW can be a liability if requiring disposal but also represents a considerable resource that can be beneficially recovered, for instance by the recycling of materials such as aluminum cans, metals, glass, fibres, etc., or through recovery operations such as conversion to energy and composting. The total annual municipal solid waste generation in New Borg El Arab city has increased more than 36% since 2000, to the current level of 20–25 tons per day (Nahdat Misr company). Organic material is typically the main constituent, up to 60% of total municipal solid waste in the city. Clearly, new waste management practices are needed.

### 3.2.5 Transport

#### Existing road network

NBC is today mostly an industrial city with most workers commuting from Alexandria. The city is connected with Alexandria through a number of main roads namely the Alexandria-Cairo Desert Road (Al Kafory Road) and the New Borg El Arab City-Matrouh Road. In addition, NBC is connected with the national railway system through the Alexandria-Borg El Arab railway which can be employed in the future as an urban/suburban public mass transport system. Finally, NBC is connected with the International Airport through a single 2-lane road.

#### Existing public transport system

NBC faces a considerable lack of public transport services. Shortfalls in public transport have created market opportunities for the informal sector collective taxis and the tuk-tuks, small moped taxis, which have the advantage of changing their schedules and deviate from licensed routes in response to passenger demand and congestion, even though this might be illegal. On the other hand, collective taxis and tuk-tuks create a number of transport problems that affect not only public transport but also adversely affect the entire transport system.

#### Existing pedestrian and bicycle transport

In general, the more transportation options that are available, the better the access. Non-motorized modes are important transport choices, for trips made entirely by walking or cycling and to support public transport. In urban areas, walking and cycling are often the fastest and most efficient ways to make short trips. NBC faces a considerable lack of pedestrian and bicycle infrastructure. The infrastructure does not prioritize space for bicycles and pedestrians. Specifically, the lack of indicated crossings increases the risk of accidents and leaves pedestrians feeling unsafe, thereby reducing these basic sustainable means of transport significantly.

## Railway line and stations in NBC

The Alexandria–Borg El Arab line operates on the same track as the Alexandria–Mersa Matrouh line. The actual travel time between the Alexandria core area and NBC is around 1.5 hours. The vehicles operated on the line are inadequate to fulfil reasonable quality services, as they are outdated, poorly maintained, and have diesel engines with poor acceleration, deceleration and speed and poor seat quality. Two stations exist in NBC, namely 25 January station and Borg El Arab station. The two stations have recently been renewed, and are in a good condition. However, the feeder systems (public buses and private operated mini-buses) to the railway stations to serve the passengers commuting to their actual destinations within the NBC are lacking.

## Borg el Arab International Airport

The Borg El Arab International Airport is located about 40 km southwest of Alexandria Centre and 14 km east of NBC. The airport consists of a new terminal building, administration and service buildings as well as cargo facilities. Currently the airport has one runway with a length of 3,400 m and a width of 45 m. The airport is planned to become the main airport of Alexandria, and aims to serve passengers and cargo for Alexandria and the surrounding governorates. The airport will also help to improve the tourist development for the western region, especially Borg El Arab and the north coast.

### 3.3 Stakeholders involved

The stakeholders involved in this FS belong to the following categories:

1. New Borg Al Arab City Authority
  - President
  - Vice-president
  - Head of Development Dep.
  - Head of Electricity Dep.
  - Head of Housing & Services
  - Head of Infrastructure Dep.
  - Head of Roads Dep.
  - Head of Design Dep.
  - Head of Environment Dep.
  
2. New Borg Al Arab Investors Association
  - Faragalla/President/CEO
  - Farco/CEO
  - Unitel/CEO
  - Mancro/CEO
  - Summer Moon/CEO
  - Alex for Seeds/CEO
  
3. Governmental Bodies
  - Dep. of Transportation/Head



Alex Water Co./CEO  
Alexandria Environmental Affairs Agency  
Org. of Investment/Head

4. NGOs/CDAs  
Sahwa NGO  
Local CDA  
Religious Association
5. Residents  
Names omitted due to confidentiality reasons

## 4 Scope

Early on during the development of this Feasibility Study, the experts involved decided to consider the following sectors for which the Vision of NBC as an EcoCity and the possible sustainability Scenarios would be proposed along with the associated impacts:

- Residential
- Commercial/Public facilities
- Industrial
- Services/Utilities
- Transport

### 4.1 Sectors considered

#### 4.1.1 Residential

The residential sector of New Borg El Arab, which for the purpose of this Feasibility Study has been analysed from an energy-efficiency perspective, is mainly characterized by the following features (more specifically described in Table 1):

- No thermal insulation
- Lightweight envelope
- Non-ventilated roofs
- Poor indoor air quality (low ventilation rate considering that smoking is allowed everywhere)

*Table 1. Specification of a typical existing building in New Borg El Arab.*

Building specification	Value
Building location	New Borg El Arab
Building orientation	Facing north
Number of storeys	3
Total floor area	750 m <sup>2</sup>
Wall material	Red brick

Wall thickness	20 cm,
Finished roof	Uninsulated
Roof material	Asphalt shingles
Slab	Reinforced concrete, uninsulated
Window area	15% of wall area
Windows	Single pane, clear glass, wood frame
Overhangs	None
Air leakage	15 ACH50
Natural ventilation	Year-round
Space conditioning	Central AC, SEER 8
Space heating	Gas, 78% AFUE
Cooling and heating setpoints	26 °C (cooling), 20 °C (heating)
Water heater	Gas standard
Lighting	34% CFL hardwired, 34% CFL plugin
Refrigerator	Standard
Cooking range	Gas, conventional
Clothes washer	Standard
Clothes dryer	Standard

In addition, a residential survey has been carried out within this project, the purpose of which was to understand the state of art of the residential sector in terms of buildings features and utilization (occupant behaviour) of NBC. The final objective is to process the questionnaire data in order to design specific and dedicated building solutions for the construction of an energy efficient new ECO residential district in NBC. In particular, the survey covered different aspects; from the building construction information to the occupants' behaviour. The results will be discussed more in detail when describing the scenarios proposed for the Residential sector.

#### 4.1.2 Commercial/Public facilities

The authorities of New Borg El Arab have built a number of services for the city as it can be seen in Annex 1, at the end of which there is also a row showing the services envisioned in the new NBC Masterplan for comparison. With regards to social services there are twelve nursery schools spread over the different neighbourhoods. In relation to educational services there are nine schools including basic, experimental, secondary, Azhar (religious) and industrial education. Also, there are four commercial markets distributed around the city and three mosques built by the local authorities, as well as a church. There is a public hospital and six health care units. Other public services that can be also found in the city are: cultural centre, occasions hall, sports club, youth hostel, training centre, bakery, traffic administration building, police station, fire brigade, national security, administration building, post office, telegraph and telephone, bus

station, endowments building, parking building, agriculture administration and court of justice.

#### 4.1.3 Industrial

New Borg El Arab is a major industrial city over 6.3 thousand acres. In the 4 industrial zones industrial activities include: engineering, electrical, food, timber, plastics, paper, spinning, weaving, building materials, metallic, mechanical, chemical, pharmaceutical and various other industries. NUCA provides plots of industrial, warehouses, and workshops. Main industry sectors are food, chemicals, engineering and textiles. Major factories are listed in Table 2.

*Table 2. Major factories in each sector.*

Industry sector	Factories	
Chemicals	<ul style="list-style-type: none"> <li>• New Marina</li> <li>• Rubex for Plastic &amp; Acrylic Manufacturing</li> <li>• The International Group for Modern Coatings</li> <li>• Egypt Bentonite &amp; Derivatives Co.</li> </ul>	<ul style="list-style-type: none"> <li>• Pyramid Glass Company</li> <li>• Evyab Egypt</li> <li>• IICP</li> <li>• Abco Group</li> <li>• Others</li> </ul>
Food	<ul style="list-style-type: none"> <li>• Faragalla</li> <li>• Sakr for food</li> <li>• Ossian Food</li> <li>• Fine Foods</li> </ul>	<ul style="list-style-type: none"> <li>• Alexandria For Seeds</li> <li>• Borg Alarab for food Ind.</li> <li>• Others</li> </ul>
Engineering	<ul style="list-style-type: none"> <li>• Man Crew for metal constructions</li> <li>• Anborg</li> <li>• Sarhan Steel</li> <li>• Valley Of The Kings For Metal</li> </ul>	<ul style="list-style-type: none"> <li>• Unitel</li> <li>• Tuporco</li> <li>• Others</li> </ul>
Textiles	<ul style="list-style-type: none"> <li>• Borg El Arab for spinning (Eshra Tex)</li> <li>• Filmar</li> <li>• Elvy weaving</li> <li>• Elvan</li> </ul>	<ul style="list-style-type: none"> <li>• Mediterranean Textile</li> <li>• Rubyred</li> <li>• Others</li> </ul>

In total there are 522 producing factories (an investment capital of 4.113 billion pounds, with an annual production of 5.292 billion pounds), which provided 37761 jobs paying 113.7 million pounds annually. 28% of these are large factories (investments more than 15 million Egyptian pounds), 46% is considered medium factories (investments between 1 and 15 million Egyptian pound) and 26% is considered small factories (investments less than 1 million Egyptian pound).

Moreover, there are 170 factories under construction (an investment capital of 482.255 million pounds and an annual production value of 514.053 million pounds), which will provide 7446 jobs paying 22.338 million pounds annually.

Many of Borg El Arab Major Industries are International for instance Fargallah for food products, Fine Foods for food products, Abco group for Detergents, The International

Group for Modern Coatings and Rubex for Plastic & Acrylic Manufacturing. Other industries in Borg El Arab are aimed mainly to the local market, such as Filmar, Elvy weaving, Unitel, Sakr for food, Ossian Food, Pyramid Glass Company, Evyab Egypt and Borg El Arab for spinning.

#### 4.1.4 Services/Utilities

##### 4.1.4.1 Water

Potable water in new Borg El Arab city is mainly contaminated and is below Egyptian and World Health Organization (WHO) standards. The water treatment plant of the city is not properly maintained and is thus inefficient in removing salts, algae and other pathogenic microorganisms. A promising and unique solution for improvement of water quality of the city must be found out. In order to identify healthy or unhealthy potable water, research is needed on the following:

- What are the qualities of potable water in the city?
- What are the signs of a contaminated body of water?

For this purpose, the first step is to develop a checklist of signs for healthy or contaminated water based on WHO's and Egyptian standards. The second step would be to make a field trip to NBC's water treatment plant to collect the data (capacity, treatment units, skills of operators, maintenance). Moreover, additional information should be gathered about the following:

- Is the intake of water contaminated?
- What pollutants are involved?
- Was the pollution primarily caused by industries, or by domestic activities?
- What is the history of the pollution at the site? When did it become contaminated?
- Has the effect of the contamination been studied before? Investigate the sources of the pollution

The third step is to collect samples of the intake and effluents from different compartments of NBC's water treatment plant to investigate its drawbacks. The following parameters should be analyzed: turbidity, salinity, pH, conductivity, hardness, algae and faecal coliform. The last step would be to design a sustainable solution for the improvement of NBC's water treatment plant. Unfortunately, this simple plan has not been possible to realize during the development of EcoNBC project due to the impossibility to access the necessary data.

##### 4.1.4.2 Solid waste management

Problem Identification in New Borg El Arab City: Municipal Solid Waste (MSW) amounted to 20 ton/d. Problems associated with organic fraction of Municipal Solid Waste are:

- Source of odor emission
- Vermin attraction

- Toxic gas emission
- Leachate generation

The sources of solid waste are shown in Figure 4 whereas examples of the present condition are provided in Figure 5.



Figure 4. Sources of solid waste in New Borg al Arab city. (Dr. Ahmed Tawfik and Mohamed El-Samadony, E-JUST)



Figure 5. Examples of the present condition. (Dr. Ahmed Tawfik and Mohamed El-Samadony, E-JUST)

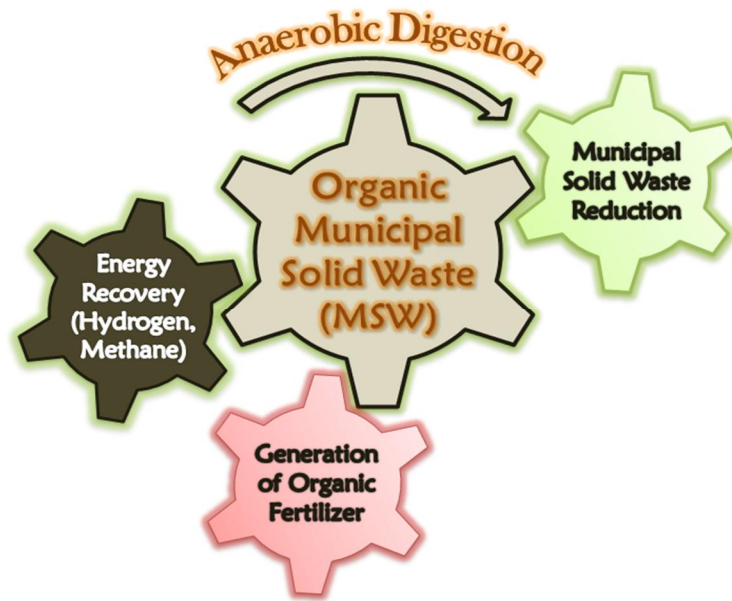

Figure 6. Sustainable solution: biowaste to energy via anaerobic digestion. (Dr. Ahmed Tawfik and Mohamed El-Samadony, E-JUST)

Biogas production from biowaste using anaerobic digestion, presented in Figures 6 and 7, is technically sound, financially viable, environmental friendly and easy to operate and maintain by local community for long term sustainability.

**Source:**

Yebo Li, Stephen Y. Park, Jiying Zhu (2011)

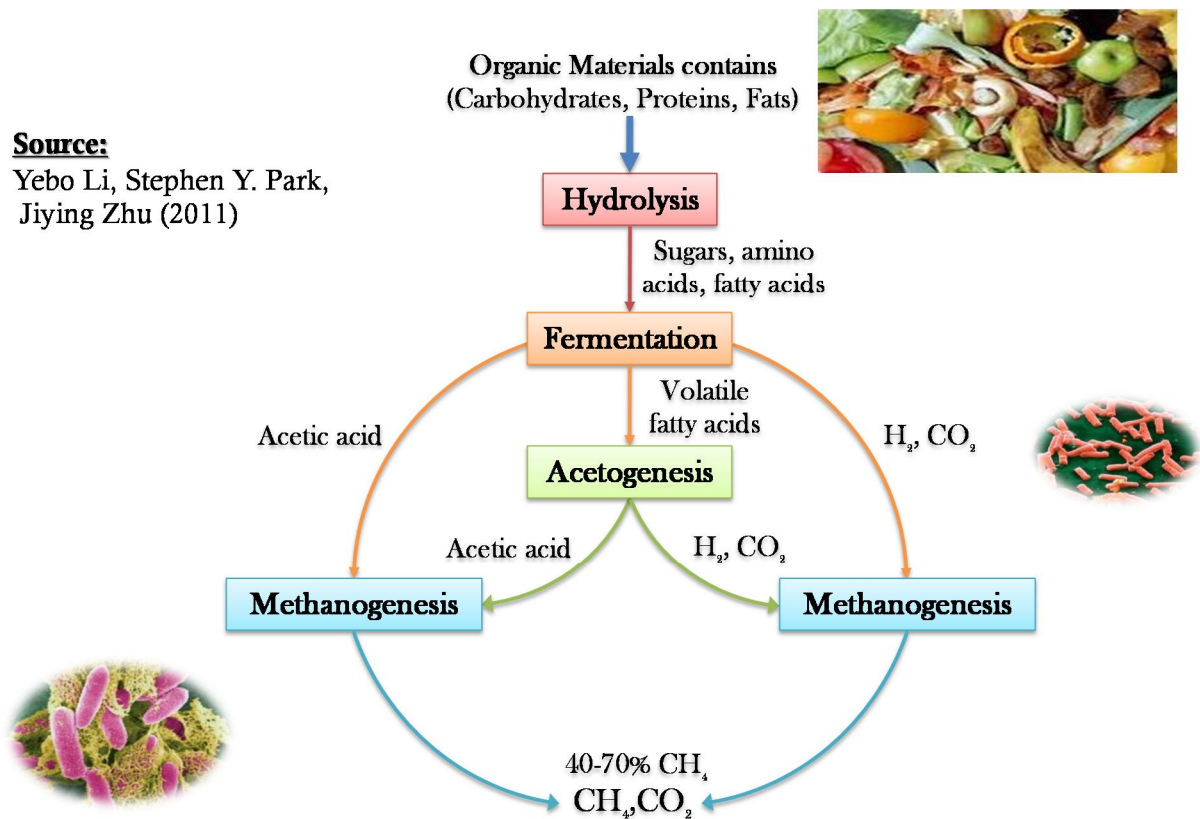

Figure 7. Degradation of organic material through Anaerobic Digestion (AD). (Yebo, Li et al., 2011)

An on site biogas unit that can be taken as an example of applicable technology, and the specifications of which are described in Figure 8, is capable of producing biogas from the organic fraction of municipal waste of 120 inhabitants.

Inhabitants:

Assume: 10 floors/ building

2 families/ floor

6 capita/ family

Solid waste rate: 0.5 kg-solids/ c. d

Therefore, Amount of solids = 0.5 (kg-solids/ c. d) X

10 (floors/ building) X 2 (families/ floor) X 6

(capita/ family) = 60 kg-solids/ d

Volume of digester:

Assume:  $\gamma$ -solid waste = 200 lbs/ yard<sup>3</sup> = 120

kg/m<sup>3</sup>

Residential Waste (uncompacted)

Therefore, Q-solid waste = 60 (kg-solids/ d) / 120

(kg/m<sup>3</sup>) = 0.5 m<sup>3</sup>/d

Assume, T = 20 d

Therefore, V-digester = 0.5 (m<sup>3</sup>/d) X 20 (d) = 10 m<sup>3</sup>

Assume, h = 2.5 m

V-digester =  $(\pi/4) d^2 X h$

Therefore, d = 2.2 m

Amount of biogas:

Assume: COD = 40 g/L

Therefore, Organic load = 0.5 (m<sup>3</sup>/d) X (40,000) g/m<sup>3</sup> = 20,000 g/d = 20 kg-COD/d

Biogas quantity = 0.3 (m<sup>3</sup>-biogas/kg-COD) X 20 (kg-COD/d) = 6 m<sup>3</sup>-biogas/d

Amount of saved energy:

A typical family of six uses 1.5 m<sup>3</sup>-biogas/ d.

Biogas consumption of building = 10 (floors/ building) X 2 (families/ floor) X 1.5 (m<sup>3</sup>-biogas/ d) = 30 m<sup>3</sup>-biogas/d

Therefore, % of saved energy = 6 (m<sup>3</sup>-biogas/d) / 30 (m<sup>3</sup>-biogas/d) X 100 = 20%

Cost:

Varied 10000 – 15000 L.E depends on material (concrete, steel, plastic, etc.).

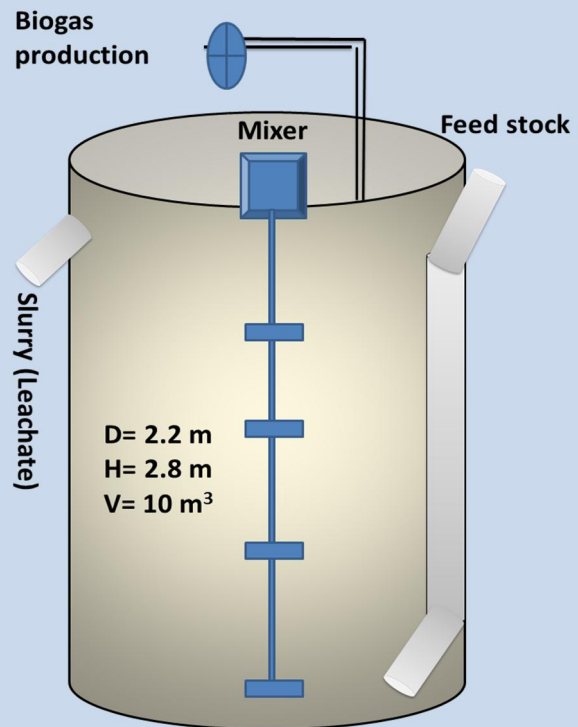

Figure 8. On site biogas unit from organic fraction of municipal waste for 120 capita. (Dr. Ahmed Tawfik and Mohamed El-Samadony, E-JUST)

#### 4.1.5 Transport

NBC is connected with Alexandria through a number of main roads namely Alexandria-Cairo Desert Road (Al Kafory Road) and New Burg Al Arab City-Matrouh Road. In addition NBC is connected with the national railway system through Alexandria-Borg El Arab railway which can be employed in the future as urban/suburban public mass



transport system. Finally, NBC is connected with the International Airport through a single 2-lanes road way. The transportation systems connect NBC with Alexandria are shown in Figure 9.



Figure 9. External road and rail network and site location of NBC. (Dr. Mohamed Shahin, CGCE)

It is worth mentioning that NBC road network does not have names for some road links. Based on the road inventory survey, the following items can be highlighted:

- There is no road hierarchy based on road capacities, importance or functions. This in turn would lead to traffic congestion, increasing traffic accident rates, and reducing the efficiency of the road network as a whole.
- Incompatibility of certain intersections with safety provision and traffic operations.
- Lack of road signs and markings particularly at approaches to intersections.
- Lack of organized and proper pedestrian facilities, especially at street crossings.
- Lack and insufficient parking and drop-off provisions, particularly near the main buildings. This would lead to illegal parking in the surrounding streets and usually cause traffic accidents.
- Insufficient, poor and unorganized of NBC public transport facilities and/or mass transit.



Figure 10. Present transport arrangements in NBC from left to right: passenger train stopping at a station, unofficial tuk-tuk stopping area, terminus of microbus routes. (Dr. Mohamed Shahin, CGCE)

NBC faces a considerable lack of public transport services. Shortfalls in public transport have created market opportunities for the informal sector collective taxis and tuk-tuk, which have an advantage of changing their schedules and deviate from licensed routes in response to passenger demand and congestion, even though it might be illegal. An unofficial tuk-tuk stop is shown in Figure 10. On the other hand, collective taxis and tuk-



tuk create a number of transport problems that affect not only public transport but also diversely affect the entire transport system as:

- They are operated at unorganized manner without a comprehensive view or plan;
- Their network covers all road networks, and in many precincts duplicates, and competes with bus services;
- They often interrupt traffic by stopping suddenly or slowing at curbs to collect/drop passengers low capacity comparing to bigger busses; and
- They are in poor technical condition contributing significantly to air pollution and high-energy consumption.

NBC faces a considerable lack of pedestrian and bicycle infrastructure. The infrastructure is not prioritizing space for bicycles and pedestrians. Specifically missing indicated crossings increase the risk for accidents and feeling unsafe, thereby reducing these basic sustainable means of transport significantly.

The Alexandria – Borg El Arab line operates on the same track of Alexandria – Mersa Matrouh line. The actual travel time between Alexandria core area and NBC needs around 1.5 hour. The operated vehicles on line is inadequate to fulfill reasonable quality services as they are outdated, poorly maintained, diesel engines with poor acceleration/deceleration/speed, and poor seats quality.

Two stations are exists on NRC namely 25 January station and Burg Al Arab station. The two stations are newly renewed and they are in good condition. The feeder systems (public buses and private operated mini-buses) to the railway stations are missing to serve the passengers commuting to their actual destinations within the NBC.

The Borg El Arab International Airport is located about 40 km southwest of Alexandria Centre and 14 km east of NBC. The airport consists of a new terminal building, administration and service buildings as well as cargo facilities. Currently the airport has one runway with a length of 3,400 meters and a wide of 45 meters.

Table 3 presents some indicators about the existing transportation system in NBC. As can be seen from the table, the total length of the existing road network in NBC is about 316 Km which constitute about 4 km per 1000 inhabitanicies. No fixed public transport routes are dedicated. Microbuses/tuk-tuk represents the highest share of the daily passenger trips with about 71% while private motorized modes represent about 28%. The share of daily passenger trips by foot represents only 1%. Overall average trip length is 12.7 km and average trip time is 14.6 min and the average speed is 52 km/hour. Average journey time to work by private motorized modes is about 13 minutes and by microbuses/tuk-tuk is about 23 minutes (extra by about 76%). The annual veh-km is about 27 million while the annual veh-hour is about 5.4 million. Finally, the annual CO2 emission is roughly estimated at 31.9 kilo ton and the total energy consumption by transport sector is 426 Tj.

Table 3. Transportation Indicators for the Base Year 2013 in NBC.

Indicator	Base Year 2013	
Population	80000	
Total length	316.71	Km
Length of road per thousand inhabitant	4	km per 1000 inhabitant
Length of reserved public transport routes per thousand inhabitants	0	
Kilometers of dedicated cycle lane per thousand of inhabitants	0	
Public transport kilometers per inhabitant	0	
Percentage of daily passenger trips on foot and by bicycle	1%	
percentage of daily passenger trips by private motorized modes	28%	
Percentage of daily passenger trips by minibuses and Tok-Tok	71%	
Percentage of population that lives within a given distance (300 m) from transit stops/stations (public transport)	0	
Average passenger car occupancy rate	1.3	
No of passenger cars per thousand inhabitant	N/A	
Share of journeys to work by car	N/A	
Average time of journey to work by private motorized modes	13.20	min
Average time of journey to work by public transport/other modes	23.10	min
Average pedestrian distances to hospitals, services, schools, business areas	N/A	
Annual passenger transport fatalities per million inhabitant	N/A	
Annual CO2 emissions	31.90	Kilo ton
Energy consumption	426.50	Tj
Energy consumption per road based public transport passenger kilometer (at vehicle)	0	
Energy consumption per rail based public transport passenger kilometer (at vehicle)	0	
Average Trip Length	12.7	Km
Average Trip Time	14.6	min
Average Speed	52.0	Km/hr
Average annual Veh.Km	278908697	veh.km
Average annual Veh.hr	5363629	veh.hr

## 5 Vision

The vision for turning NBC into an EcoCity was developed by a team of Finnish and Egyptian experts through a number of workshops held in Finland and Egypt. From the beginning, it was clear that the vision should remain ambitious but still possible to achieve given the necessary political will and social commitment.

The team of experts decided to define the vision around three main issues of concern for each of the sectors considered in the scope of the FS (Residential, Commercial/Public Facilities, Industrial, Services/Utilities, Transport). The issues of concern chosen are Energy, Water and Waste, plus an additional category named Other independent issues (materials, social, etc.). In order to provide also a summarized view of the vision across sectors, a General "sector" was defined.

Quantitative and qualitative targets were set for each of the sectors in relation to the issues of concern chosen.

Several workshops with stakeholders were also organized to collect their feedback on the vision (and scenarios) proposed. The content was then refined accordingly. A more detailed view of the content developed can be found from Annex 2.

Table 4. Sectors and issues of concern considered for the Vision.

Issues of concern	Sectors considered for the Feasibility Study					
	General	Residential	Commercial/ Public facilities	Industrial	Services/Utilities	Transport
Energy						
Water						
Waste						
Other independent issues						

## 5.1 General overview

### 5.1.1 Energy

The vision foresees a number of measures to be applied by all sectors like energy efficiency, smart use of energy, use of renewable energy sources (particularly solar energy), possibility to sell extra energy to the grid, waste to energy, efficient lighting solutions, use of biofuels, use of local materials.

Other measures, even though included in the general overview, are more sector-specific, like monitor and trace hazardous chemicals, cleaner production (green industry), electric cars, electrification of railway connection between NBC and Alexandria, pedestrian and bicycle lanes, improved bus system, car-pooling, Intelligent Traffic Systems (ITS), reduced use of private cars in city centres (parking fees), etc.

Finally, there are some measures related to public awareness, as well as the necessary legal framework and information to be provided.

### 5.1.2 Water

In relation to water, the vision includes measures like water conservation, improved water quality, use of non-conventional water resources, fresh water management, recycling and reuse of treated waste water, provision of fresh drinking water and sanitation, rain harvesting and increased public awareness.

### 5.1.3 Waste

Here the vision proposes measures like in situ sorting of waste, waste minimization, recycling, low cost technologies for waste water treatment, biogas and biofuel

production from waste, solid waste treatment, pollution prevention, reduction of emissions (see also energy) and increase public awareness. And finally, in this case, the previous are completed with an additional measure directly related with consumption patterns: market for used goods (flea market, online sales...).

#### 5.1.4 Other independent issues

This additional category includes measures in relation to those issues that don't fall within any of the other but are still perceived as very important like protection of aquatic ecosystems, conservation and sustainable use of land, sustainable green cover, biodiversity, green areas, good governance, use of eco-friendly chemicals, minimization of use of raw materials, health and safety, etc.

## 5.2 Vision and targets per sector

### 5.2.1 Residential

#### Energy

The vision contemplates the possibility to sell extra energy to the grid, and to develop a local building energy code (including lighting), solar water heating and solar air conditioning, waste to energy technologies, efficient lighting solutions, and in general, energy efficiency and smart energy use. In addition, use of local materials should be promoted and the awareness of the public should be increased.

#### Targets:

- *100% net renewable energy in all new buildings.*
- *Reduce by 50% in 10 years the total energy consumption compared to business as usual.*

#### Water

The vision includes water conservation and water quality, use of non-conventional water sources (e.g. solar desalination), fresh water management, recycling and reuse of treated waste water, provision of fresh drinking water and sanitation, rain harvesting and increased public awareness.

#### Targets:

- *30% less water consumption (including water recycling) compared to business as usual.*
- *100% pure drinking water for everyone.*
- *50% water treated using renewable energy sources in 10 years.*
- *100% sanitation for everyone.*
- *Respect carrying capacities in terms of water availability.*

#### Waste

The vision includes in situ sorting of waste, waste minimization and increased public awareness.

*Targets:*

- *Near 100% of the waste (including both solid waste and waste water) is treated, recycled and/or reused.*
- *100% of hazardous waste is properly treated.*

### Other independent issues

Here the vision describes aspects that don't relate precisely to the previous issues of concern like for example protecting aquatic ecosystems, conservation and sustainable use of land, sustainable green cover, biodiversity, green areas or good governance.

*Targets:*

- *Intensifying water pollution prevention to reduce health hazards and damage to ecosystems.*
- *Reducing salinity, combating desertification, reducing cropland expansion, preventing soil pollution and degradation.*
- *Reducing plant uprooting and removal of natural vegetation.*
- *In general, improving the legislation.*
- *Introducing the adequate legislation to allow and regulate the use of renewable energy.*

### 5.2.2 Commercial/Public facilities

#### Energy

The vision includes solar water heating and solar air conditioning, waste to energy, use of efficient lighting solutions, energy efficiency and smart energy use, monitor and trace hazardous chemicals, and a green policy for all.

In addition, use of local materials should be promoted and the awareness of the public should be increased.

*Targets:*

- *Enforcement of the existing law to close businesses at a given time.*
- *Improved energy efficiency (efficient lighting, refrigeration).*

#### Water

The vision contemplates water conservation (including agricultural activities) and water quality, use of non-conventional water sources (e.g. solar desalination), fresh water management, recycling and reuse of treated waste water, provision of fresh drinking water and sanitation, rain harvesting and increased public awareness.

*Targets:*

- *100% use of non-conventional water for irrigation and non-conventional irrigation techniques.*

#### Waste

The vision includes recycling, low cost technologies for waste water treatment, biogas production from waste and increased public awareness.

*Targets:*

- *Near 100% of the waste (including both solid waste and waste water) is treated, recycled and/or reused.*
- *100% of hazardous waste is properly treated.*

### 5.2.3 Industrial

#### Energy

The vision includes cleaner production (green industry), monitoring (in-plant control), maintaining the energy cycle, renewable energy and energy efficiency (ISO 50000, etc.), efficient lighting solutions, monitor and trace hazardous chemicals, possibility to sell extra energy to the grid, smart energy use. In addition, enforcement of environmental laws and regulations should be achieved and public awareness increased.

*Targets:*

- *100% of industries energy audited on regular basis.*
- *100% of industries having a green policy, self-monitoring and continuous improvement processes.*
- *Shared responsibility in trade (hazardous chemicals).*
- *Upgrading of outdated equipment through enforcement and incentives.*
- *Use of renewable energy.*

#### Water

The vision promotes non-conventional water resources (e.g. solar desalination), recycling and reuse of treated waste water, rain harvesting and increased public awareness.

*Targets:*

- *100% of industries water audited on regular basis.*
- *100% recycling of waste water where applicable.*
- *Enforcement of the law regulating discharge into water streams.*

#### Waste

The vision promotes waste minimization, solid waste treatment, recycling, recovery (including waste to energy), pollution prevention and increased public awareness.

*Targets:*

- *Near 100% of the waste is treated, recycled and/or reused.*
- *100% of hazardous waste is properly treated.*

#### Other independent issues

The vision promotes the use of eco-friendly chemicals, minimization of raw materials and Occupational Safety & Health (OSH).

*Targets:*

- *OHS rules should be followed by all employees at all times. Develop processes to support this.*

## 5.2.4 Services/Utilities

### Energy

The vision includes minimization of electricity consumption, in public spaces, daily services within walking distance (around 500 m), efficient lighting solutions, providing consultancy on energy efficient solutions, providing energy audit service (e.g. through E-JUST Energy Office), smart energy use, energy information and tips available (e.g. from E-JUST Energy Office), ESCO companies, and increase public awareness.

*Targets:*

- *60% reduction of energy consumption in Government offices compared to business as usual.*
- *E-JUST Energy Office up and running in the near future.*

### Water

The vision includes rain harvesting, providing clean water and increased public awareness.

*Targets:*

- *30% reduction of water consumption in the Service sector.*
- *All septic tanks should be modified to prevent ground water pollution, and service to empty the tanks should be available.*

### Waste

The vision includes markets for used goods (flea market, online sale...), well-functioning waste management services available and increased public awareness.

*Targets:*

- *100% garbage collection.*
- *At least one functioning market place for used goods (either physical or online).*
- *Near 100% of the waste is treated, recycled and/or reused.*
- *100% of hazardous waste is properly treated.*

## 5.2.5 Transport

### Energy

The vision includes use of biofuels, electric cars, fuel cells, electrification of railway connection between Borg El Arab City and Alexandria, pedestrian and bicycle lanes, improving the bus system, busycles, supporting car-pooling, energy efficiency, increasing the use of public transport, increasing cycling and walking, Intelligent Traffic Systems (ITS), introducing information systems for travellers, car-free zones, traffic

calming measures, bus and HOV priority, reduce use of private cars in city centre (parking fees).

In addition, traffic laws and regulations should be enforced and public awareness should be raised.

*Targets:*

- *Modal Split: public transport share 50%.*
- *Modal Split: pedestrian/cycling share 10%.*
- *Decrease private car share 40%.*
- *15% use of electric cars by 2035 for the best scenario.*
- *100% cars should be regularly checked and maintained.*

## Water

The vision includes rain harvesting for the road system and increased public awareness.

## Waste

The vision promotes biofuel from waste, hydrogen production, reduction of emissions (see energy), recycling (tyres, other parts), recovery and again increased public awareness.

*Targets:*

- *Enforcement of law regulating disposal of old cars.*
- *100% tyres recycled.*
- *Near 100% of the waste is treated, recycled and/or reused.*
- *100% of hazardous waste is properly treated.*

## 6 Scenarios

To evaluate the future situation for NBC in the year 2035 and its technical, environmental impacts, the "scenario technique" was adopted. A scenario can be defined as a logical and plausible (but not necessarily probable) set of events that may lead to the future situation. The aim is to consider a range of possible "futures" and to provide various development strategies.

### 6.1 General scenarios

The general scenarios agreed and developed jointly through a number of focused workshops are:

- Business As Usual scenario (BAU)
- Low Investment Sustainability scenario (LIS)
- High Investment Sustainability scenario (HIS)



These scenarios were first defined in a general way, applicable to all sectors, and then developed more in detail for each of the sectors included in the scope of this FS. Annex 3 contains the detailed description of the scenarios.

#### 6.1.1 BAU scenario

The scenario implies that things will continue in the future as they are now, the evolution pattern will be the same. Therefore this point of view, BAU is basically the description of the current situation, including population and economic growth and also the content of the Strategic Plan and the results for the performance indicators proposed by the EcoNBC team. The performance indicators proposed for a basic diagnosis of the current situation are:

- Energy consumption  
[kWh/year]  
energy source
- Water consumption  
[m<sup>3</sup>/year]
- Material consumption  
[kg/year]
- Emissions  
[kg CO<sub>2</sub> equivalent/year]
- Wastewater  
[m<sup>3</sup>/year]
- Solid waste  
[tonnes/year]  
hazardous/non hazardous

Even though the performance indicators selected should be feasible since they are quite basic, gathering the necessary data has proved to be a considerable challenge, particularly in the case of the Industrial sector. Since the same data are needed also for the calculations of the different scenarios considered (see Chapter 7 Impacts), EcoNBC team has made a number of decisions to overcome the unavailability of data or the unreliability of the existing data. These decisions and assumptions will be explained ahead.

However, EcoNBC team would like to draw the attention of all involved stakeholders towards the importance of making the data available in order to support sustainable development in Egypt.

#### 6.1.2 LIS scenario

The Low Investment Sustainability scenario should contain primary energy efficiency measures along with the introduction of renewable energy sources and improved user behavior regarding energy efficiency. Minimization of lighting energy consumption, as

well as the consistent use of passive solutions in Residential and Commercial sectors (see Annex 3), and the general implementation of energy audits for the Industry sector, should also be included in the LIS scenario.

In relation to Water, the LIS scenario includes water conservation measures as well as monitoring energy and water quality inside the buildings. In relation to Waste, this scenario considers separating waste at neighbourhood and district levels.

There are a number of measures specifically related to the Transportation sector like the improvement of public transport and traffic control systems, the enforcement of traffic laws, or separate lanes for different means of transportation. Other measures are related to the Industry sector like the development of low cost technologies, the optimization of material and energy flows in industrial processes or improving the skills of the employees.

In addition to this, the LIS scenario also includes other general measures like sustainable planning and design, the creation of databases for different sectors or awareness raising programmes (energy, water, waste, lifestyle...).

### 6.1.3 HIS scenario

In relation to Energy, the High Investment Sustainability scenario includes the use of advanced renewable energy technologies and solutions (see Annex 2).

For Water, the HIS scenario considers upgrading the water distribution network, fresh water management and rain harvesting, as well as increasing the production and use of non-conventional water resources (e.g. desalination).

In relation to Waste, this scenario includes hazardous waste dumping sites, classification of the different industries for better common waste management, solid and liquid waste management for the Industry sector, use of non-conventional techniques for improving the added value from materials waste, 100% recycling efficiency especially for water (Zero Liquid Discharge technology).

Additionally, the HIS scenario also includes other social and economic measures with impacts on the main issues of concern selected, like improving sanitation and health, building more schools and hospitals, developing industrial ecoparks, mass transport and Intelligent Traffic Systems, electric vehicles, creation of local SMEs around sustainable technologies, products and systems, etc.

## 6.2 Scenarios per sector

Based on the data and the tools/software available, several scenarios have been defined more in detail for the Residential and Transport sectors as it will be described next. These scenarios were then used as basis for energy and CO<sub>2</sub> emissions, and cost calculations respectively.

### 6.2.1 Residential sector

The buildings considered here relate to two investment scenarios: Low Investment Sustainability scenario (LIS) and High Investment Sustainability scenario (HIS). In the first case, the design includes exclusively low cost solutions, while in the second case technologies commonly associated with Net-zero houses are included. Both cases have been compared to a reference case, called Business As Usual (BAU), which refers to the minimum requirements of the Egyptian energy code, as presented in the aforementioned studies. In particular, active and passive ventilation systems, different external envelope solutions, PV and solar thermal systems have been considered. Furthermore, different solar PV field sizes have been considered, but only for the high investment scenario. (Reda et al., 2015)

The research has been carried out in three phases: investigation of the main behaviour patterns of occupants in relation to energy consumption, assessment of relevant technologies and, finally, energy analysis. The latter aspect has been carried out using TRNSYS software. The investigation phase was conducted as a survey. The goal of the survey was to understand the occupant behaviour concerning the use of windows, shading systems and domestic hot water in typical New Borg El Arab residential areas. Stakeholders, local authorities and energy market key players were involved in the technology assessment phase in order to list cost-effective systems and building envelope solutions for each scenario: BAU, LIS and HIS.

The aim of this phase was to create a list of technologies that suit New Borg El Arab in the local context for both high and low investment scenarios. A two-day meeting was organized by VTT and E-JUST with the local stakeholders, authorities and energy market key players in order to select, among other issues related to EcoNBC project, the most effective residential energy saving solutions. Particular attention was given to the capability of the construction workers, to the availability of technical passive and active solutions in the Egyptian market and to the recent local research findings, described in the introduction. Thus, the Low Investment scenario (LIS) includes only simple and affordable solutions, while the High Investment scenario (HIS) includes technologies commonly applied in Net zero energy buildings. In both scenarios, solar technologies were preferred, among others, because of the high level of solar irradiance in Egypt, as stated in the introduction. The Business As usual Scenario (BAU), on the other hand, refers to the minimum requirements of the Egyptian energy code. The chosen technologies for each case are listed in Table 5.

Moreover, for the three considered cases: BAU, LIS and HIS, an air to water heat pump was included for supplying cooling and heating energy.

Table 5. List of technologies selected by local stakeholders, authorities, energy market key players, VTT and E-JUST expert.

	Business as usual (BAU)	Low investment scenario (LIS)	High investment scenario (HIS)
System technologies	Incandescent 20% and fluorescent lamp 80%	Fluorescent light bulbs	LEDs
	Free cooling system relying on opening windows when rooms are occupied (natural ventilation only)	Free cooling system using vents (natural ventilation only)	Mixed free cooling ventilation system (through vents + mechanical ventilation)
	-	Unglazed solar thermal collectors	Glazed solar thermal collectors
	-	-	PV
Envelope solutions	-	External reflective paint	External reflective paint
	Double wall of half red-brick with 5 cm air gap in between	Insulation (5 cm on the ground floor and the Roof, 3 cm on the external walls)	Insulation (6 cm on the ground floor and the Roof, 5 cm on the external walls)
	-	Shading system	Shading system
	Double glass window	Double glass window	Double glass low-e (low thermal emissivity) window

#### Energy system: BAU

The system used in this scenario is the simplest considered. It consists of a storage hot water tank and a heat pump. Since there are not solar technologies involved, the components C1, P2, solar collectors, PV, batteries and inverter are not part of the BAU system. The considered air to water heat pump refers to the model ERLQ004-008CV3 of the series Daikin Altherma air to water heat pump. TRNSYS type 941 has been used to model the HP; furthermore, the catalogue data for both heating and cooling has been created according to the abovementioned product technical data sheet. The main technical features of the heat pump are shown in Table 6.

Table 6. Main technical features of the heat pump model Daikin Altherma air to water heat pump – ERLQ004-008CV3.

Heat pump technical data, model ERLQ004-008CV3, Daikin®[43]	
Max. water flow temperature for heating	55 °C
Air temperature operating limits (cooling mode)	-10 °C – 45 °C
Air temperature operating limit (heating mode)	-20 °C
Water temperature operating limits (cooling mode)	5 °C – 18 °C
Water temperature operating limits (heating mode)	25 °C – 60 °C
Cooling capacity / COP at A35/W7	6.82–2.9 kW ; -
Cooling capacity / COP at A45/W18	6.38–2.25 kW ; -
Heat output / COP at A7/W35	5.12–4.57 kW ; -
Heat output / COP at A2/W55	4.54–2.58 kW ; -
Blower power	53 W

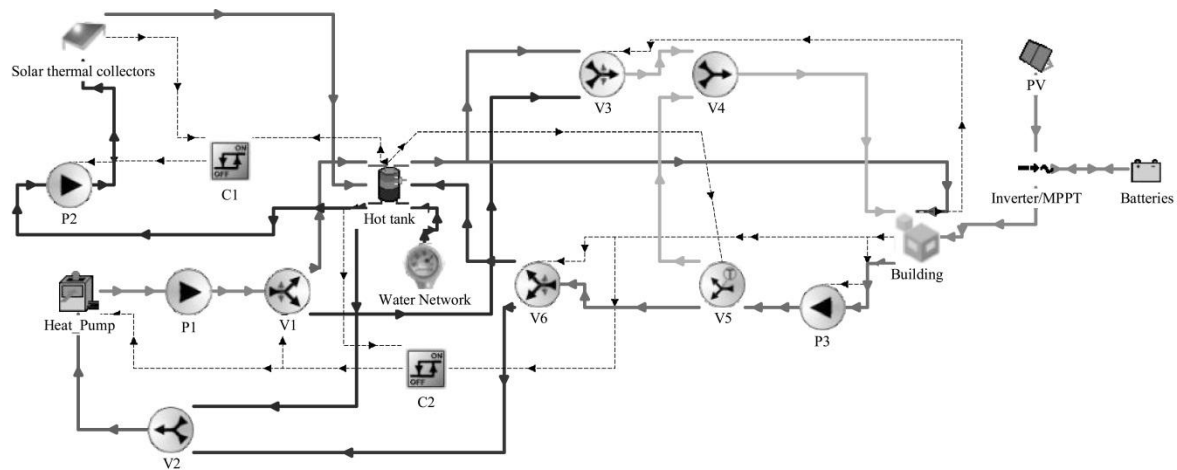

Figure 11. TRNSYS schematic view of the HIS system. (Dr. Francesco Reda, VTT)

The heat pump supplies heating energy to the building via the storage tank, while cooling energy is supplied directly. The right part of the Figure 11 shows the supply loop, components V4, V5 and P3. V5 is responsible to divert a part of the load flow rate to V4 in order to reach the inlet temperature required by the fan coils. The fan coils inlet temperatures are 45°C and 16°C respectively for heating and cooling supply. Moreover, C2 allows the heat pump to drive heating or cooling energy through V1 to the hot tank, until the temperature of the tank reaches 55°C, and to V3, in case cooling energy is required in the building. Only in summer both heating, for DHW, and cooling energies are required. Therefore, C2 gives priority to the cooling energy, forcing the heat pump to produce cooling energy first and then, when the building does not require cooling energy, C2 lets the heat pump charge the hot tank. Therefore, the hot storage tank supplies both DHW and heating loads. TRNSYS type 60 has been used to model the storage tank. All the requested parameters have been set in accordance with the data sheet of the manufacturer. Table 7 shows also the main design parameters of the tank.

#### Energy system: LIS

LIS system adds to the BaU system the unglazed solar thermal collectors. This means that the components C1, P2 and solar thermal collectors are included in the model. Table 7 shows unglazed solar thermal panel features and number. The tilt angle of the solar thermal collectors has been fixed to 40°, which is 10° more than the latitude, in order to maximize their efficiency in winter. Type 1 has been used in TRNSYS to model the solar thermal collectors. Moreover, the power of the solar circulation pumps (P2) is assumed to be 50W. C1 checks the temperature difference between the solar thermal field and the hot water tank and if the temperature difference exceeds 4°C when P2 is not running, it forces P2 to run, driving solar energy into the hot water tank. Instead, when P2 is running, C1 lets the solar circulation pump runs only if the aforementioned temperature difference exceeds 2°C.

Energy system: HIS

The authors have assessed the energy performance of the three PV system sizes used in the HIS to estimate the benefits of a PV driven cooling system. Coupling a heat pump to a PV system allows producing heating and cooling without consuming energy if the output power of the PV system is enough to supply the heat pump. Moreover, only one machine, the heat pump, is needed to supply both the heating and cooling systems. Recent research has shown the promising performance of this system configuration in the Mediterranean regions, stating that currently PV solar cooling solutions actually allow better results than the solar thermally driven ones. Therefore three HIS cases: HISa, b and c have been considered; they differ only by the size of the PV system. In particular, HISc has more PV and batteries than HISb and HISa cases. Therefore, all HIS cases add to the LIS system a PV system, an inverter and batteries. In addition, instead of the unglazed solar thermal collectors, solar flat plate glazed collectors have been used. The same TRNSYS type has been used to model them. Table 7 shows flat plate collectors design features and their configuration for each HIS case.

Table 7. Main design parameters of solar unglazed and flat plate thermal collectors and a storage hot water tank.

Thermal panel model: Unglazed and Flat plate collector				
Net surface (one panel)		2.3 m <sup>2</sup> (1.2X1.9 m)		
Nominal flow rate (one panel)		120 l/h		
LIS	Solar thermal unglazed collector Efficiency $\eta_{stc}$	$\eta_0 = 0.9$ (Intercept efficiency)	$a_1 = 20 \text{ W/m}^2\text{K}$ (Efficiency slope)	$a_2 = 0 \text{ W/m}^2\text{K}^2$ . (Efficiency curvature)
HIS	Solar thermal flat plate collector Efficiency $\eta_{stc}$	$\eta_0 = 0.78$ (Intercept efficiency)	$a_1 = 3.2 \text{ W/m}^2\text{K}$ (Efficiency slope)	$a_2 = 0.115 \text{ W/m}^2\text{K}^2$ . (Efficiency curvature)
Number of panels (connected in series)		LIS, Unglazed - 5; HISa,b and c Glazed: 3;		
Hot and cold storage tank model ECO COMBI 3 VC Cordivari				
Capacity		500 l		
DHW Corrugated stainless heat exchanger 316L Capacity		26.6 l		
Solar fixed heat exchanger Capacity		11.5 l		
Solar fixed heat exchanger pressure drop		3000 Pa		
Insulation thickness		10 cm		
Insulation conductivity		0.135 W/mK		

Table 8 shows the main design parameters for PV, batteries and inverter systems and also their configuration for each HIS cases. The whole PV system consists of PV modules, a set of batteries and a maximum power point tracking (MPPT) inverter. Types 194, 48 and 47 have been used to model, respectively, PV, inverter and batteries in TRNSYS. All the parameters requested by the aforementioned types have been set according to the manufactures specifications. Therefore, the PV modules charge the battery through the MPPT and the batteries supply electricity to the loads through the inverter.

The tilt angle of the PV modules of the HISa and b has been set 20° in order to optimize them for summer use. Instead with regard to the HISc case, since the available roof

surface for each apartment is not enough to place all the PV modules, 8 modules have been placed on the south façade of the apartment.

Table 8. Main design parameters of PV, batteries and inverter systems.

Sharp PV module ND-R245A5 [47]			GWL-power, battery model SP-LFP200AHA [48]		
Module short-circuit current at reference conditions	8.68	A	Cell Energy Capacity	200	Ah
Module open-circuit voltage at reference conditions	37.6	V	Cells in parallel	3–2	-
Reference temperature	298.15	K	Cells in series	8–18	-
Reference insolation	1000	W/m <sup>2</sup>	Charging efficiency	0.9	-
Module voltage at max power point and reference conditions	30.9	V	Max. current for cell charging	400	A
Module current at max power point and reference conditions	8.1	A	Max. current for cell discharge	-400	A
Temperature coefficient of <i>I</i> <sub>sc</sub> at (ref, cond)	0.138	-	Max. charge voltage for cell	2.8	V
Temperature coefficient of <i>V</i> <sub>oc</sub> (ref, cond,)	-0.329	-	Number of Batteries	HISa: 18 connected in series; HISb: 36 (2 lines of 18 batt. each); HISc: 36 (3 lines of 18 batt. each);	
Module temperature at NOCT	320.65	K	Inverter model ET6415N [49]		
Ambient temperature at NOCT	293.15	K	Regulator efficiency	0.78	-
Insolation at NOCT	800	W/m <sup>2</sup>	Inverter efficiency (DC to AC)	0.96	-
Module area	1.65	m <sup>2</sup>	High limit on fractional state of charge (FSOC)	0.95	-
tau-alpha product for normal incidence	0.95	-	Low limit on FSOC	0.2	-
Tilt angle	HISa and b: 20°; HISc: 20°–90°;	Degrees	charge to discharge limit on FSOC	0.3	-
Numer of modules	HISa: 5 strings of 2 modules each; HISb: 9 strings of 2 modules each; HISc: 13 strings of 2 modules each	HISa: 10 (Roof mounted); HISb: 18 (Roof mounted); HISc: 26 (18 mounted on the roof and 8 on the south façade);	Power output limit	HISa, <b>b</b> and c: 3200 (48V)	W
			Inverter efficiency (AC to DC)	0.8	-

## 6.2.2 Transport sector

The following three scenarios are developed in the framework of this study for the future development of the transport system in NBC (Shahin & Hedman, 2014):

### Business As Usual scenario

The Reference scenario (see Figure 12) is based on continuation of the existing travel behaviour of the year 2014 in the future, according to the following assumptions:

- Forecasted population based on the proposed master plan and increase rate of population.
- Little change in the modal split to the benefit of the bus mode.
- Change in the road infrastructures based on the master plan.

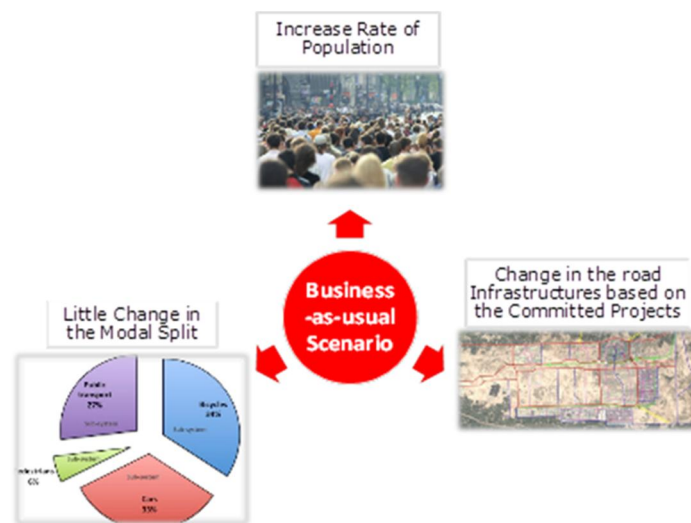

Figure 12. General description of the Business as usual scenario. (Dr. Mohamed Shahin, CGCE)

### Low Investment Sustainability scenario

This scenario includes some of the measures for saving, shifting, and smoothing traffic (see Figure 13). The main features of this scenario can be summarized as follows:

- Mixed Land Use Approach
- Introduce Bus Rapid Transit Network on the main roads of NBC
- Use the exiting Mini Buses/Tuk-tuk fleet as a minor organized public transport feeders
- Creation of Pedestrian and Cycling Facilities
- Enforcement of traffic laws
- Develop Effective Ride Sharing and Car Pooling System
- Introduce Parking Management system in city centers
- Introduce Calming Measures in city centers
- Raising Public Awareness
- Use of Biofuel/natural gas powered public transport



- Maintenance of vehicles to the manufacturer's specifications and applying for Vehicle Scrapping Program

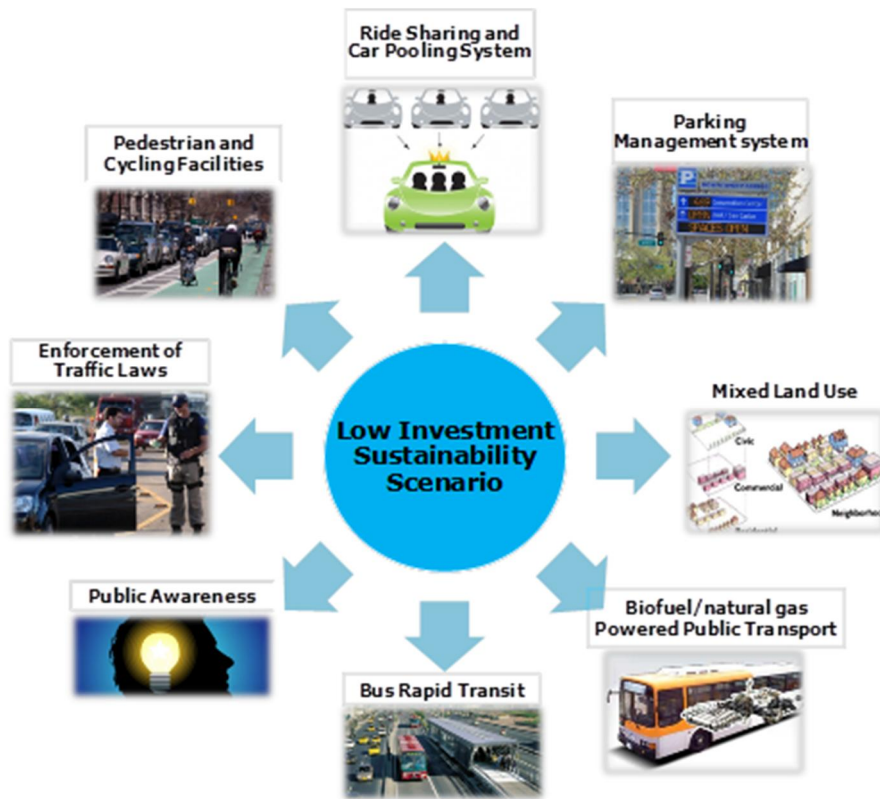

Figure 13. General description of the Low Investment scenario. (Dr. Mohamed Shahin, CGCE)

Figures 14a and 14b present the proposed public bus transport routes and their catchment areas for Low Investment Sustainability Scenario. Figure 15 shows an example for the proposed road cross sections which contains PT and walking/bike reserved widths.

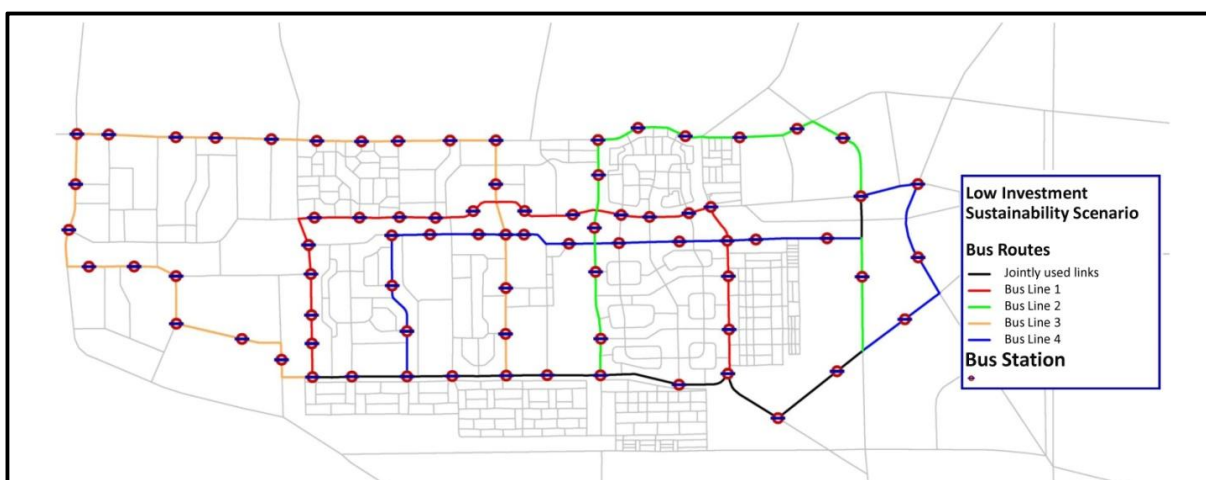

Figure 14a. Proposed Public Transport Routes for the Low Investment Sustainability Scenario. (Dr. Mohamed Shahin, CGCE)

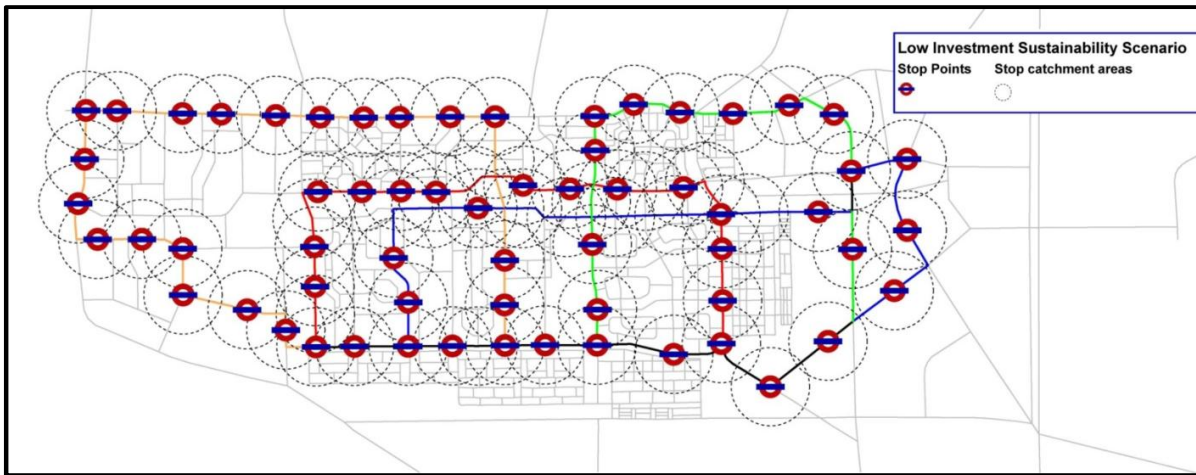

Figure 14b. Catchment Areas for the proposed Public Transport Routes in the Low Investment Sustainability Scenario. (Dr. Mohamed Shahin, CGCE)

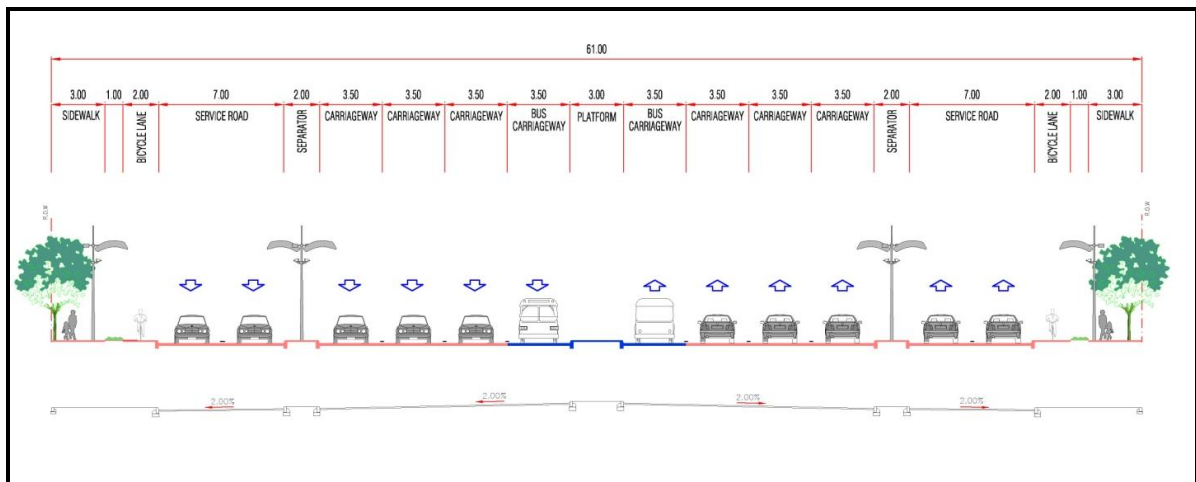

Figure 15. Proposed Typical Cross Sections for the Main Roads in NBC. (Dr. Mohamed Shahin, CGCE)

### High Investment Sustainability scenario

This scenario includes the measures of Low Investment Sustainability Scenario plus the following measures (see Figure 16):

- Introduce of New Regional Railway connecting with Alexandria City
- Introduce of Tram and Light Rail Transit Network on the main roads of NBC
- Optimize use of available Infrastructure through Implement Intelligent Traffic System
- Use of Electric vehicles and Fuel cell cars
- Use of Biofuels for cars
- Introduce of freight transport centers

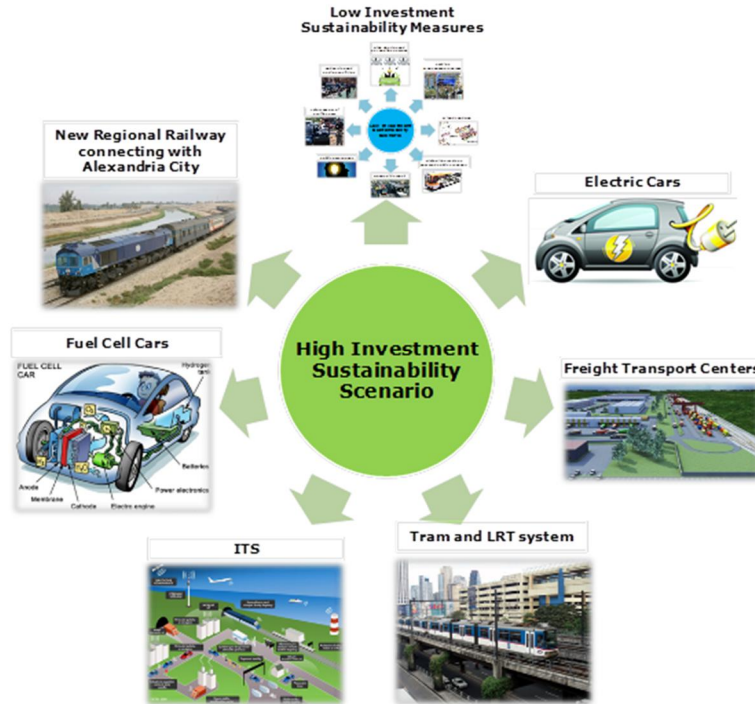

Figure 16. General description of the High investment sustainability scenario. (Dr. Mohamed Shahin, CGCE)

Figures 17 and 18 present the proposed public bus transport routes and their catchment areas for Low Investment Sustainability Scenario. Figure 19 shows an example for the proposed road cross sections which contains PT and walking/bike reserved widths.

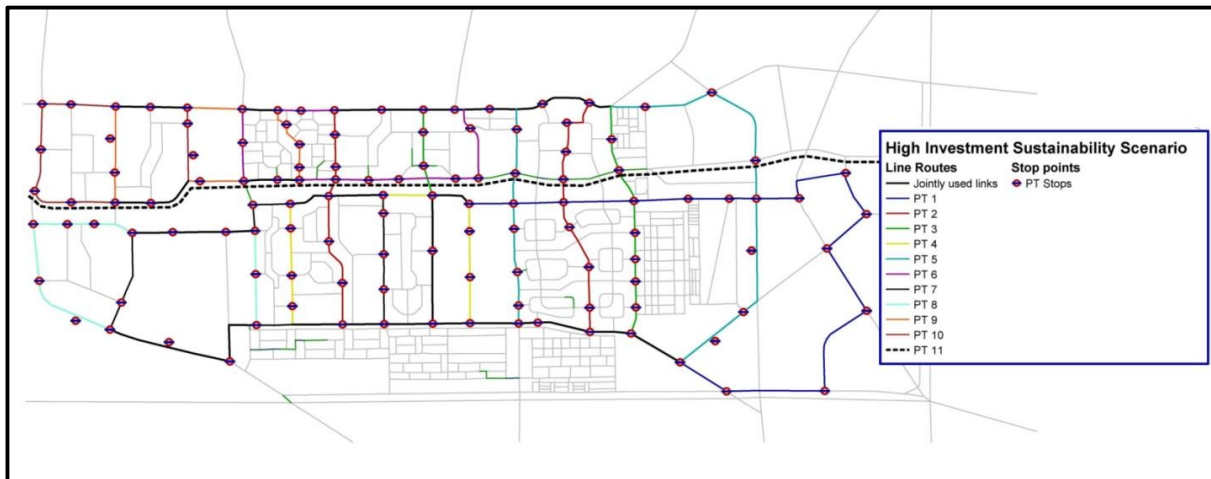

Figure 17. Proposed Public Transport Routes for the Low Investment Sustainability Scenario. (Dr. Mohamed Shahin, CGCE)

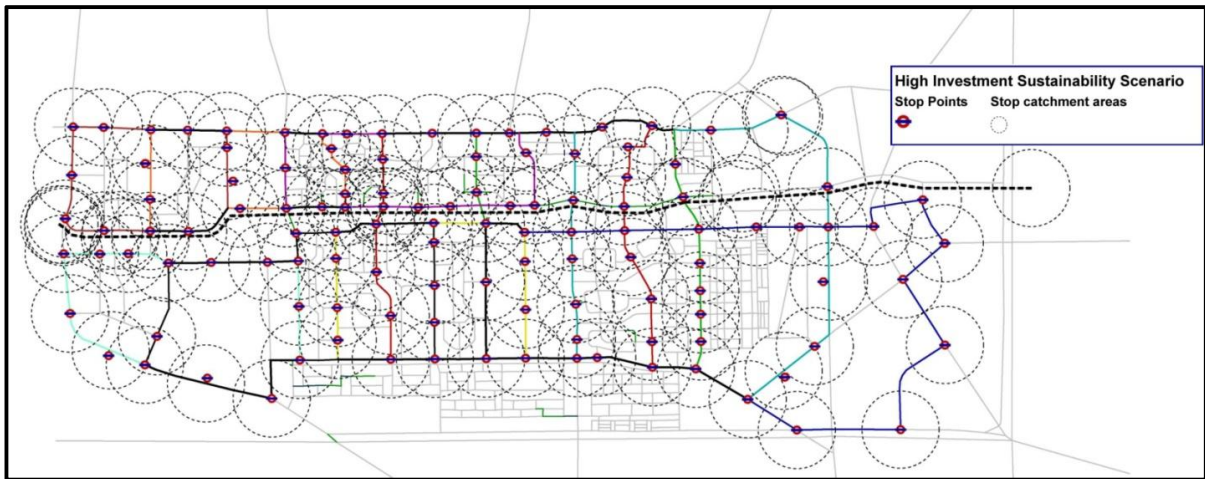

Figure 18. Proposed Public Transport Routes for the Low Investment Sustainability Scenario. (Dr. Mohamed Shahin, CGCE)

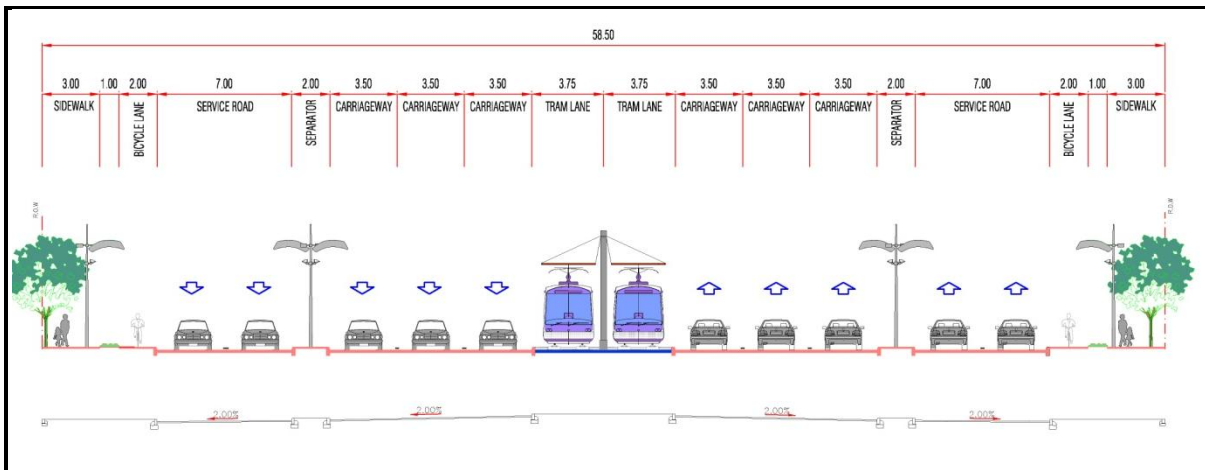

Figure 19. Proposed Typical Cross Sections for the Main Roads in NBC. (Dr. Mohamed Shahin, CGCE)

## 7 Impacts

### 7.1 Residential sector

The impacts of the scenarios in the residential sector were analyzed for CO<sub>2</sub> emissions and costs. In addition, a brief expert evaluation of social factors was made.

#### 7.1.1 Energy and CO<sub>2</sub> emissions

The impact was calculated by in detail simulating one case residential building, and more specific one apartment in the building. The simulations were done with TRNSYS software. The scenarios were done based on the approach described earlier. The result

from one building was multiplied with the total amount of apartments, 178 125 apartment units according to the master plan.

It was assumed that all buildings had the same shape as the case building, being 4 storeys high. It must be noted that this would probably in reality not be the case. It shall also be noted that if a building would be higher than 4 storeys, the rooftop area will not anymore be enough for the amount of PV panels per apartment assumed in the earlier calculations.

Table 9 shows the energy performance of the district and the CO<sub>2</sub> emissions calculated on the energy balance. It is to be noted that even if these results indicate an overall surplus energy production in the scenario HISc, this applies for the residential sector only. Actually it would mean that the residential buildings would be able to sell surplus electricity to for example public buildings like schools or health centres or commercial buildings like offices. The overall CO<sub>2</sub> emissions in these results shall be interpreted as the residential buildings surplus energy would replace average electricity and therefore impact the other sectors' emissions. Since this analysis only takes the residential sector into account, these emissions are shown as negative for this sector.

*Table 9. Annual final energy demand of the heating and cooling systems for the residential sector in New Borg El Arab City, PV produced, consumed and exported energies and final energy balance, which includes the appliances energy consumption of each scenario.*

*Note: CO<sub>2</sub> emissions are calculated based on the final district energy balance and assuming the average Egyptian emission factor for electricity for all energy use.*

	BaU	LIS	HISa	HISb	HISc
Final district energy demand [GWh]	619,6	315,5	219,8	219,8	219,8
Districts' produced PV energy [GWh]	-	-	335,5	603,9	763,1
Districts' consumed PV energy [GWh]	-	-	114,7	189,7	205,7
Districts' exported PV energy [GWh]	-	-	116,6	236,2	343,5
Final districts energy balance [GWh]	846,2	542,1	215,1	20,4	-103,0
CO <sub>2</sub> emission [1000t]	394,3	252,6	100,2	9,5	-48,0

The fundamental aim of a very energy efficient building is to reduce the building energy needs. LIS shows good results for a very energy efficient building. Indeed the annual cooling and heating building needs, around 32 kWh/m<sup>2</sup> and 29 kWh/m<sup>2</sup> (16 kWh/m<sup>2</sup> space heating and 13 kWh/m<sup>2</sup> DHW), are respectively 46% and 26% less than the annual energy demands of the BaU case building. However, a step further towards a net zero energy building was taken in the HIS case. There, the annual building heating and cooling demands are respectively 24.71 kWh/m<sup>2</sup> (11.71 kWh/m<sup>2</sup> space heating and 13 kWh/m<sup>2</sup> DHW) and 23.26 kWh/m<sup>2</sup>, respectively 16% and 28% less than the energy demands of the LIS case building.



The energy system has a central role in a very energy efficient building. Indeed, energy is needed to produce DHW and to cover both space cooling and heating demands. The HIS case was further divided into three: HISa, b and c; they have different PV systems configurations. The final energy consumption of LIS, around 15 kWh/m<sup>2</sup>, signifies that a very energy efficient building can be achieved using simple and affordable envelope and energy system solutions. Indeed, it is half of the final energy consumption of the BaU. Particularly interesting are the results of HISa: the final energy consumption, around 5 kWh/m<sup>2</sup>, is about 65% less than that of LIS.

Finally, remarkable results were achieved in both HISb and c, using a PV system size that is within the range of the power capacities conventionally utilized in the residential sector of the Mediterranean countries. In fact, both HISb and c buildings can be considered net zero energy buildings, since the on-site renewable system (PV) supplies almost the whole energy heating and cooling system demand. Their final energy consumptions are, respectively, 1.48 kWh/m<sup>2</sup> and 0.69 kWh/m<sup>2</sup>. These figures do not include the home appliances' consumption. Instead, they have been considered within the final energy balance of each scenario, which considers also the dumped energy from the PV system as being exported to the national grid. Both HISb and HISc results support the potential success of a very low energy building concept in Egypt. Indeed, the HISb has a final energy balance that exceeds slightly zero, around 1 kWh/m<sup>2</sup>, while the HISc has a negative final energy balance, around -5 kWh/m<sup>2</sup>, meaning that the building produces a surplus of energy over the year.

It is evident that the impact is very big if these scenarios would be applied in the whole city. Savings up to 605,7 GWh could be achieved and 282,2 K tons of CO<sub>2</sub> emissions could be avoided. This amounts to the total CO<sub>2</sub> emissions of 117 853 Egyptians. This can be considered high impact since the city is planned to host 750 000 inhabitants. These savings from only the residential sector would enable 15% of the population to live totally "carbon free", theoretically calculated. The figure becomes bigger when sustainability actions for other sectors as transport, service and industry sectors are taken into account.

In conclusion, very low energy and net zero energy buildings have been designed in line with the local context, using envelope solutions to lower their energy needs and renewable systems to achieve a near zero or a negative final energy balance. Ideally this study along with others should attract the interest of local and central administrations for planning and building new eco-friendly residential districts that include very energy efficient buildings.

#### 7.1.2 Cost effectiveness analysis

A cost effectiveness analysis (CEA) was conducted using the VTT-CEA tool on the modelled apartment building. The selected type of CEA method is Dynamic Generation Cost (DGC), which gives as a result the price of energy saved in terms of USD/kWh. Table

10 gives price information for BAU and LIS. Only technical systems that are different between the two cases are listed, otherwise the buildings are the same. More details about the method used are available in Tuominen et al. (2015).

*Table 10. List of technologies in the two scenarios including price and replacement interval estimates used in the calculation. Numbers are given per apartment.*

Scenario	System name	Investment cost (USD)	Interval for replacing the system (years)	Reference
BAU	Double red brick wall with an air gap	4914	-	Egyptian Ministry of Housing (2014)
	Incandescent (6) and fluorescent lights (24)	87	1 (incandescent), 10 (fluorescent)	Alliance to save energy (2011)
	Advanced fan coils (13) for air circulation	2080	20	Alibaba (2014a)
	Regular hot water storage tank	1500	20	Alibaba (2014b)
	Total	8581		
LIS	Insulated building envelope	6037	-	Egyptian Ministry of Housing (2014)
	External reflective paint	488	10	Egyptian Ministry of Housing (2014)
	Shading system for windows	420	20	Egyptian Ministry of Housing (2014)
	Fluorescent lights (30)	105	10	Alliance to save energy (2011)
	Free flow vents and advanced fan coils (8)	1780	20	Alibaba (2014a)
	Efficient hot water storage tank	1900	20	Alibaba (2014c)
	Unglazed solar thermal collector system	1250	20	Egyptosolar (2014)
	Total	11980		

From the point of view of the CEA calculation, the BAU scenario serves as the reference case, DGC being calculated for LIS. Table 10 gives the cost estimates used in the CEA calculation as well as the intervals for system replacements per apartment. Additionally it is assumed that in LIS on average one work day annually is used by an unskilled worker cleaning the rooftop systems and one workday by skilled professionals, such as an electrician, on system check-ups, totalling 40 USD/a using typical local costs. The calculation is made with a 10 % discount rate for 1 year of investments and 50 years of operating, maintenance and replacement costs.

The result was that the measures under consideration in a low investment scenario had a cost of 0.21 USD/kWh for energy saved. Electricity price in Egypt is heavily subsidised and even after recent price hikes is expected to settle at 0.07 USD/kWh (Kalin, 2014). It would therefore appear that the combination of energy efficiency measures studied in LIS is not at present economically sensible from a pure investment calculation perspective. However, further cuts in subsidies are expected. In EU countries the average electricity price was 0.25 USD/kWh in 2013 (Eurostat, 2014), which would suffice to make the investment profitable. Moreover, the positive effects of reduced

pollution, climatic effects and consumption of non-renewable resources may justify the somewhat higher cost.

### 7.1.3 Social impact analysis

The Social impacts of the options in the scenarios could be summarized in the following:

- Health and wellbeing impacts

This mainly relates to the public health improvements observed as a result of improved heating and cooling of buildings and air quality from more efficient transport and power generation and less demand for both.

- Poverty alleviation: Energy affordability and access

As energy demand and bills are reduced for the poor, these households have the ability to acquire more and better energy services, as well as free up income to spend on satisfying other critical needs. In addition, as utilities improve their supply-side efficiency, they can provide more electricity to more households, thereby supporting increased-access initiatives, which is often an important stated objective of supply-side energy efficiency activities in developing countries.

- Increased available income

Across all income levels, when energy efficiency in the household improves, reduced energy bills provide increased disposable income for households, individuals, and enterprises. The effect of increased spending and investment can in turn result in positive macroeconomic effects.

- Increased asset values

There is evidence that investors are willing to pay a rental and sales premium for property with better energy performance. Some values of this premium have been estimated for commercial property.



Figure 20. Effects of energy efficiency improvements. (Ryan & Campell, 2012)



Generally speaking, energy efficiency improvements have multiple social, economic and environmental effects summarized in Figure 20.

7.2 Transport sector

7.2.1 Evaluation process for projecting the transportation energy consumption and emissions under different policies

Figure 21 illustrates the multi-stepped process proposed to evaluate different policy techniques. Based on the transport activities, the expected vehicle stock and the new technology trends, the energy consumption and emissions (in the target year) can be calculated.

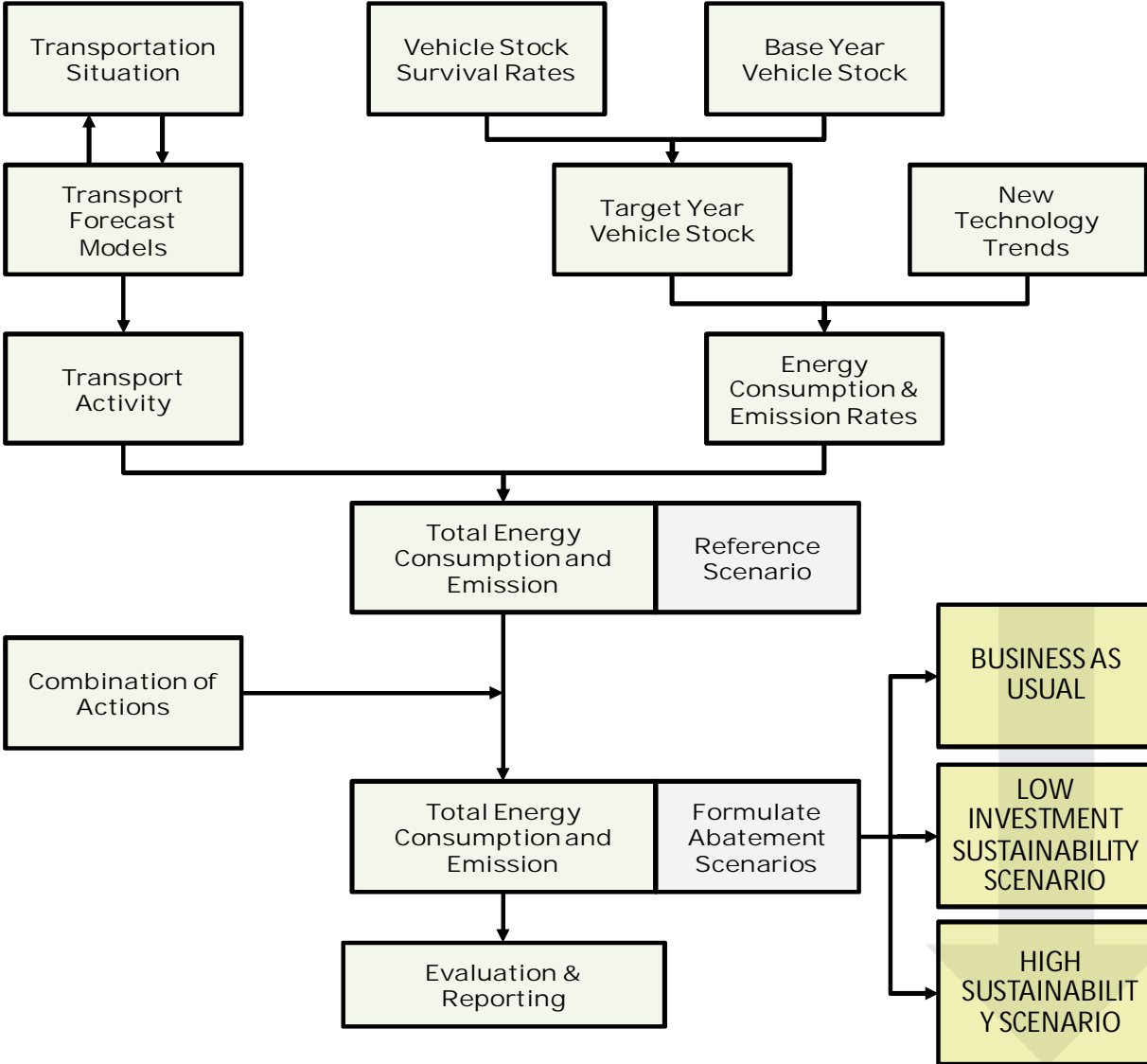

Figure 21. A Multi-stepped Process for the Evaluation of Policies Techniques. (Dr. Mohamed Shahin, CGCE)

## 7.2.2 Transport Forecast Models

A Stated Preference (SP) questionnaire refer to the individual's preference is designed and used to estimate the demand for the proposed new transport services proposed in the above two options for NBG as indicated in Figure 22. The survey contained SP exercises (choice games) submitted to the sample of respondents. The choice scenarios are constructed by combining attribute levels with each other.



MCV1	Car	Microbus&Tuk Tuk	LRT
2			
Travel time	40 Min	20 Min	10 Min
Travel Cost	LE 6	LE 4	LE 3
Waiting Time		30 Min	5 Min
Walking Time	20 Min	20 Min	10 Min
Interchanges	No Interchange	1 Interchange	1 Interchange
Which is your BEST option?	<input type="text" value="A"/>	<input type="text" value="B"/>	<input type="text" value="C"/>
Which is your WORSE option?	<input type="text" value="A"/>	<input type="text" value="B"/>	<input type="text" value="C"/>

Figure 22. An Example of High Sustainability Scenario from SP Questionnaire for NBG.

The survey was for all sets of urban communities and zones (about 30 respondents). The questionnaire contained a SP experiment regarding the choice among three different transport alternatives: Private Car, Microbuses/tuk-tuk and Bus Rapid Transit (BRT) for the Low Investment Sustainability Scenario and Private Car, Microbuses/tuk-tuk and Light Rail System (LRT) for the HIS scenario. After collecting survey sheets, the choice of such question was recorded. The logit model calibration was estimated to analyse the expected choice behaviour, as explained in the next paragraphs. SP outputs are modal split for each scenario as shown in Figure 23. The freight transport share is adopted using the approved plans and scenarios for the Egyptian Rail Freight System developed by the Egyptian Ministry of Transport.

Finally, for the different scenarios, the future O-D matrices are determined, then "VISUM" program is applied to predict the travel conditions on the different links of the proposed scenarios road networks as well as the effectiveness of the suggested public transport systems.

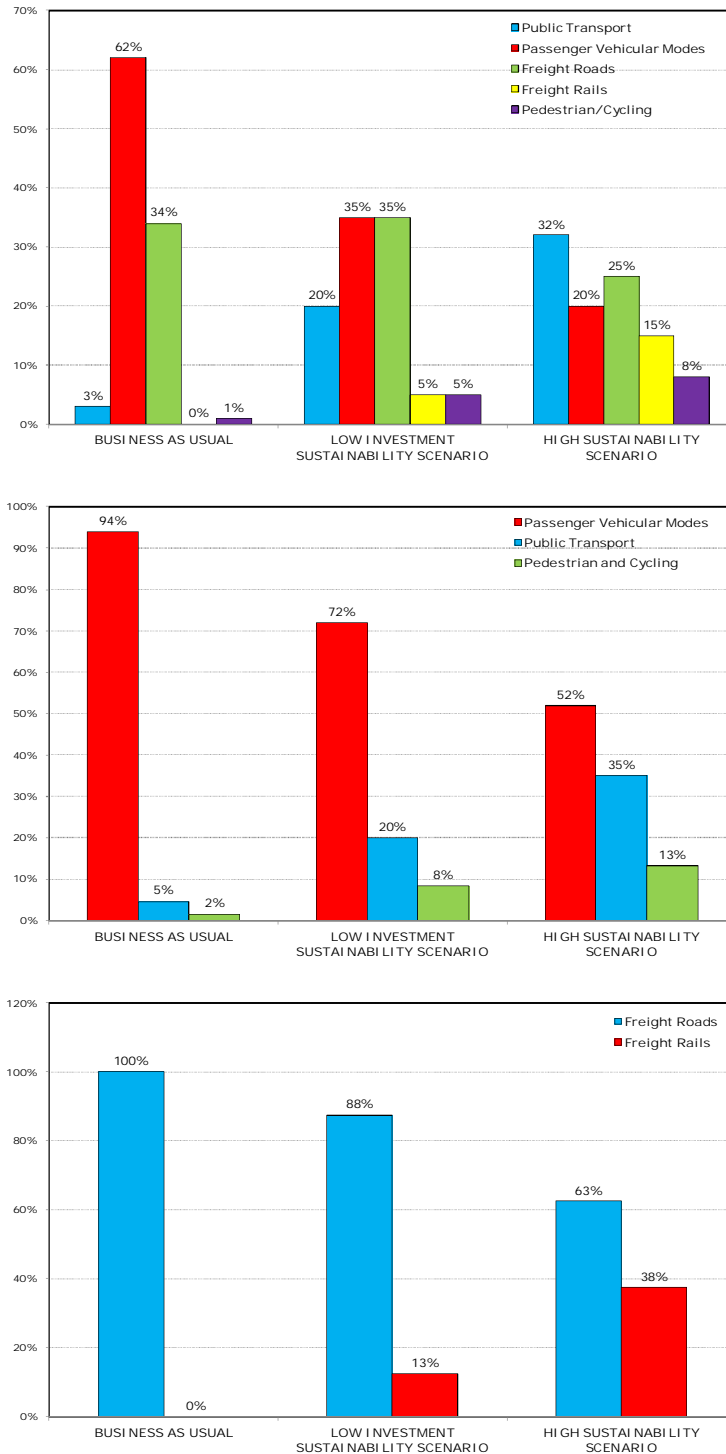

Figure 23. Modal Split for different scenarios. (Dr. Mohamed Shahin, CGCE)

### 7.2.3 Energy/Emission Rates in NBC

For the purpose of estimating energy consumption and related emission in urban areas, the structure of mobile sources have to be selected to reflect the relative importance of the various sectors and the mechanized transport modes available within each sector. Mobile sources included in this work are passenger cars, Mini buses, and Buses.

Since there are many different model years passenger car on the road, this mode are further classified by age of the vehicle. They are split into vehicle ages classes (e.g. >10 years old, 5–10 years old, and < 5 years old). The determination of the energy consumption rates for different modes in NBC is based on data collected from real measurements. Table 11 presents the fuel consumption rates (FCR) for the private car according to the distribution of age classes as well as the calculated composite fuel consumption rate (each class's fuel consumption rate is multiplied times its relative prevalence in the fleet). This composite fuel consumption rate represents the full fleet of the private cars. Table 12 shows the fuel consumption rates for different road transport modes in NBC. These rates are found to be suitable at the average speeds listed in the table.

*Table 11. Fuel Consumption Rates (FCR) of Private Cars in NBC for year 2013 (Gasoline).*

Mode	Class	FCR (l/100km)	Prevalence (%)	Composite FCR (l/100km)
Private Car	Up to 5 Years	8.7	19	11.292
	5 – 10 Years	10.3	27	
	10 Years and More	12.7	54	

*Table 12. Fuel Consumption Rates for different Transport Modes in NBC.*

Mode	Average Speed (km/h)	FCR by Fuel Type (l/100km)	
		Gasoline	Gas Oil
Private Car	40-50	11.292	-
Microbus	30-40	-	20.5
Public Bus	20-30	-	48.9

In order to develop the previous fuel consumption rates at different average speeds, the Swiss/German emissions model "Handbuch der Emissionsfaktoren des Straßenverkehrs 2010" has been studied within the framework of this study. It provides fuel consumption factors for all vehicle types at different urban driving patterns (i.e. different average speeds in urban areas). When these factors are displayed as a function of the average speed, the energy consumption factors tend for the most part to fall on a reasonably smooth curve. It is therefore possible to generalize the Swiss/German energy consumption factors as continuous functions depending on the average vehicle speed.

The characteristic shapes of these curves have been studied and thought that they are constant somewhat for each vehicle type (i.e. passenger cars, Mini buses, and Buses). Thus, the differences in the fuel consumption due to the changes in the average speeds are found to be constant for every vehicle type. Figure 24 presents the calculated differences in the fuel consumption due to the changes in the average speeds according to the Swiss/German emissions model.

a) Passenger Car

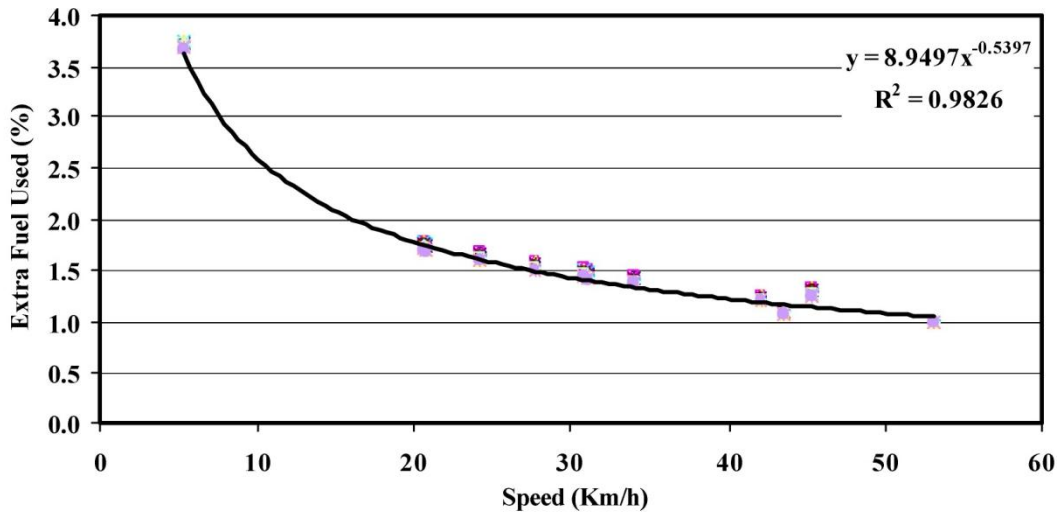

b) Mini Buses

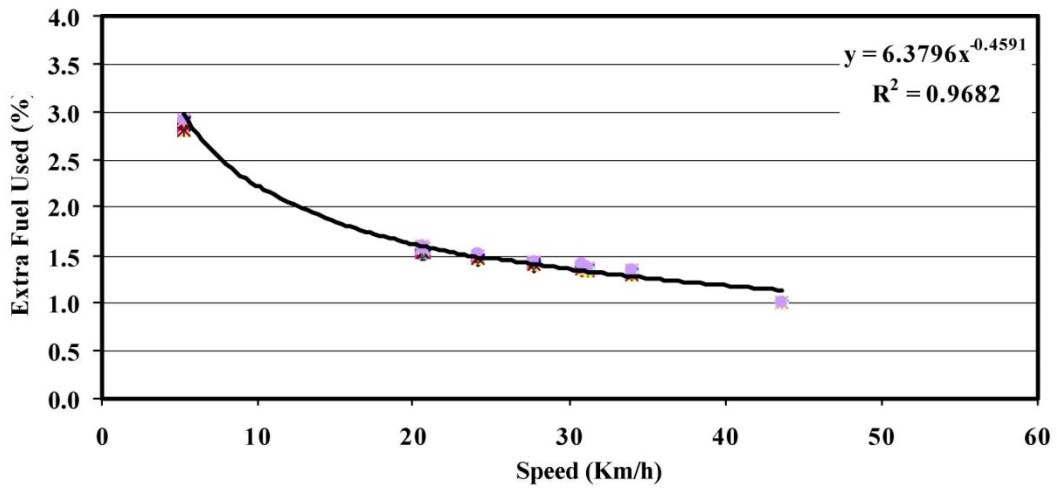

c) Buses

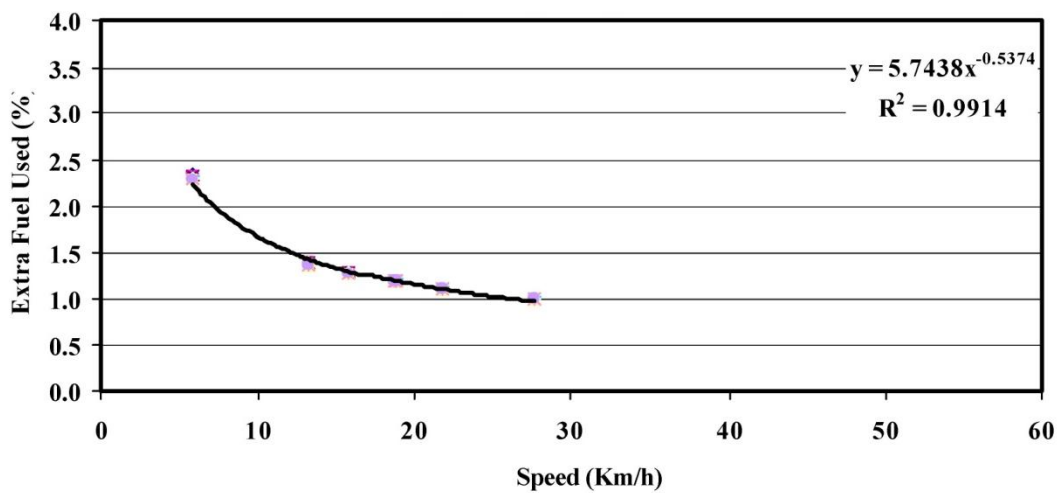

Figure 24. Extra Fuel Used due to Average Speed Distribution. (Dr. Mohamed Shahin, CGCE)

These differences are used with Alexandria fuel consumption rates, listed in Tables 11 and 12, in order to develop fuel consumption rates at different average speeds for NBG road transport sector. Then and based on data collected about the quality of different types of fuel used in Egypt, conversion factors and the emission rates for CO<sub>2</sub> are used according to fuel type.

#### 7.2.4 The Computer System "TraEco"

One of the objects of this work is to provide link between transportation and energy fields. For this purpose, the computer system "TraEco" is developed to estimate road transport energy consumption and emission in urban areas. "TraEco" is written in visual basic for applications language. The main advantage of this system is that it is simple to run and can be applied to any urban area with different transport systems, fuel types and emissions as long as the input data can be provided. In addition, this program gives the possibility to examine different fuel type distribution (i.e. fuel switching) as well as different traffic conditions.

This system consists of four main modules. The first module (Initial Data Entry) is a data editor to introduce the links number, transport modes (number and names), fuel types (number and names), and emission types (number and names). The data is stored automatically on the computer disk from which it can be displayed on the screen, printed or modified.

The second module (Data Organization Management) is to introduce sheets data according to initial input data.

The third module (Main Data Entry) is also a data editor for entering the output of the four-step travel demand models (links activity and speed) as well as the specific energy consumption and emission rates. The data is stored automatically on the computer disk from which it can be displayed on the screen, printed or modified.

The fourth module (Energy and Emission Calculation) is divided into two stages. The first stage is energy consumption and emission calculation for each link according to its average speed. The second stage is total energy consumption and emission calculation for the whole network for each transport mode. The fundamental structure of "TraEco" system is illustrated in Figure 25.

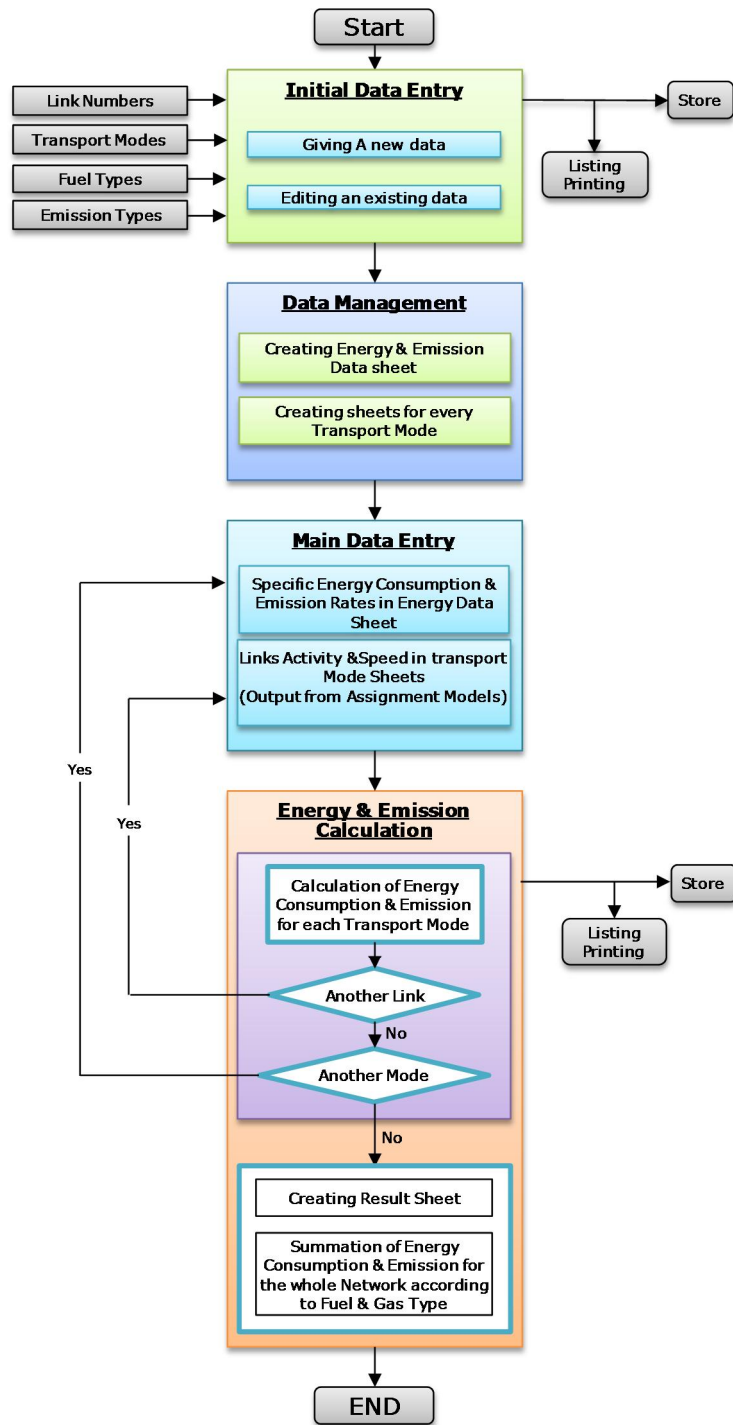

Figure 25. The Fundamental Structure of TraEco System. (Dr. Mohamed Shahin, CGCE)

### 7.2.5 Evaluation of Scenarios

Table 13 presents some indicators relating to the performance of NBC's transportation system under different scenarios as well as the existing condition.

Table 13. Transportation Indicators for Different Scenarios in NBC.

Indicator	Unit	Base Year 2013	BAU Scenario 2035	Low Scenario 2035	High Scenario 2035
Population	Inhabitans	80000	600000	600000	600000
Total Road Length	km	316.7	482.71	482.71	482.71
Length of road per thousand	km/th. inh.	3.96	0.805	0.805	0.805
percentage of daily passenger trips by private motorized modes	%	96%	94%	72%	52%
Percentage of daily passenger trips by Public Transport	%	3%	5%	20%	35%
Percentage of daily passenger trips on foot and by bicycle	%	1%	1%	8%	13%
Length of reserved public transport routes	km	0.00	0.00	98.72	208.53
Length of reserved public transport routes per thousand inhabitants	km/th. inh.	0.00	0.000	0.165	0.348
Percentage of population that lives within a given distance (400 m) from transit stops/stations (public transport)	%	0%	0%	53%	78%
Average Speed	km/h	52	38	48	46
Average Trip Length	km	12.7	14.6	6.8	6.8
Average Trip Time	min	14.6	23.1	8.5	8.9
V over C	%	48%	81%	50%	32%
Energy Consumption	Tj/year	426.5	2876	1811.9	1207.9
CO2 Emissions	Kilo Ton/year	31.9	209.1	125.0	79.7

As can be seen from the table, the total length of the road network of NBC will reach about 428 km which constitute about 0.8 km per 1000 inhabitants for different scenarios compared to 316 km and 4 km per 1000 inhabitants in the base year 2013. Compared to the base year and Business as Usual scenario which have no dedicated fixed PT routes, the low and high investment scenarios have dedicated PT routes equal to 98 km and 208 km respectively. This contributes to about 0.165 km and 0.35 km length of reserved PT routes per thousand inhabitants for the low and high investment scenarios respectively.

In the BAU scenario, private motorized vehicles (private cars and Microbuses/tuk-tuk) represent the highest share of the daily passenger trips with about 94% while the shares of daily passenger trips by PT and foot/bikes represent are only about 5% and 1% respectively. In the low and high investment scenarios, the shares of daily passenger trips by PT are 20% and 35% while the shares of daily passenger trips by foot/bikes are 8% and 13% for each scenario respectively.

Overall average trip length is 14.6 km and average trip time is 23.1 min and the average speed is 38 km/hour for BAU scenario while for low and high investment scenarios the average speeds are 48 km/hr and 46 km/hr with noticeable reduction in the average trip length and time by about 53% and 63% respectively if compared to the BAU scenario.

Under the different scenarios, great improvement of the average volume over capacity (v/c) ratio has been achieved. Under low and high investment scenarios (which include the introduction of new public systems), the average v/c ratios are 50% and 32% respectively compared with 81% under the BAU Scenario. Using the output data from the assignment (i.e. activities and average speeds) as an input data in the TraEco computer system, explained above, the total energy consumption is calculated in the year 2035 under different scenarios. The total energy consumption needed for the passenger transport in Alexandria under BAU scenario will achieve 2.876 PJ in the year 2035; i.e. with an increase rate of about 670 % of the consumption in the year 2013 (0.426 Pj).



Under LIS and HIS scenarios, significant reductions of the energy consumption are expected with about 37% for low investment scenario and 58 % for high investment scenario less in energy consumption compared to BAU scenario as shown in Figure 26.

Finally the annual CO2 emission is calculated using the "TraEco Program" for different scenarios in year 2035. In BAU scenario, the amount of Co2-emissions will achieve about 209 kilo-ton; i.e. with increase rates of about 650 % of those emitted in the year 2013 (see Figure 26).

Similar to the energy consumption under the different scenarios, significant reductions of the CO<sub>2</sub>-emissions are expected with about 40 % in low investment scenario and 62 % in high investment scenario less than those emitted in the BAU scenario.

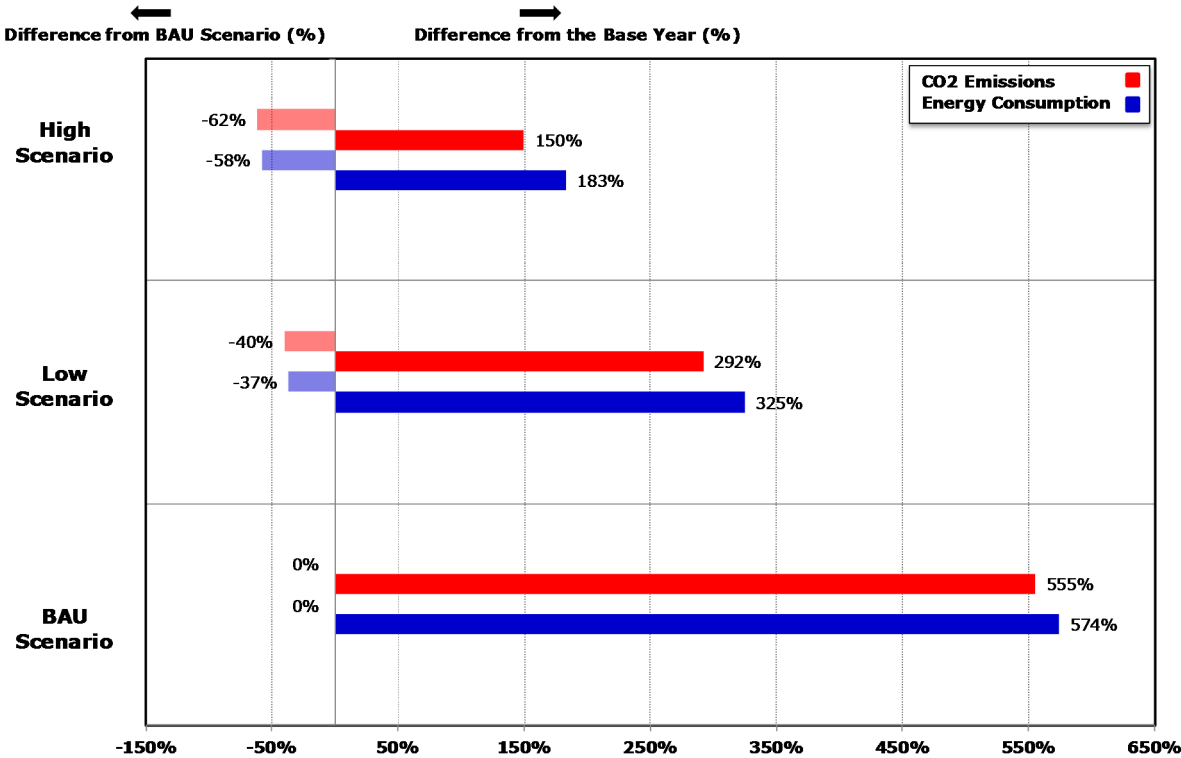

Figure 26. Energy consumption and CO<sub>2</sub> emission differences (in %) under different scenarios from the situation of the Base Year 2013 and the BAU scenario 2035. (Dr. Mohamed Shahin, CGCE)

The reasons for such reductions in the energy consumption and CO<sub>2</sub> emissions can be summarized as follows:

- The intensive modal shift from road transport to public transport.
- The improvement of the traffic conditions on the road network.
- The fuel switching from fossil fuels to electricity.

### 7.2.6 Cost analysis

The estimated capital cost for different transit systems include funding agency of acquiring right-of way, constructing these systems corridors and stations, procuring vehicles, and installing supporting systems such as fare collection, security, and passenger information systems. They include costs of design, engineering, and project management and exclude the out-year costs of reconstruction or replacement of facilities.

The Transit Cooperative Research Programme (TCRP) presents a range of capital costs for different systems, depending on facility type, station type, vehicle type, fare collection system, and other information and safety systems.

Transit length and stations for NBC

Table 14 illustrates the length and the number of stops for BRT and LRT systems within different scenarios developed in the framework of the ECO project for NBC.



*Table 14. Properties of Transit Systems in LIS and HIS scenarios.*

LIS scenario		
BRT	Length (Km)	Number of Stops
BRT Line 1	23.475	25
BRT Line 2	20.402	18
BRT Line 3	26.148	28
BRT Line 4	28.696	27
Total	98.721	98
HIS scenario		
BRT	Length (Km)	Number of Stops
PT 1 (LRT)	27.368	23
PT 2 (LRT)	38.213	27
PT 3 (BRT)	18.352	22
PT 4 (BRT)	13.174	14
PT 5 (LRT)	23.056	20
PT 6 (LRT)	13.225	17
PT 7 (LRT)	18.121	18
PT 8 (BRT)	14.335	14
PT 9 (BRT)	11.718	16
PT 10 (BRT)	10.456	12
PT 11 (LRT)	20.493	5
Total BRT	68.034	78
Total LRT	140.477	110



Capital costs for different Transit Systems worldwide

This section shows the estimated capital costs for different transit systems worldwide. (Source: Comparative examination of New Start light rail transit, light railway, and bus rapid transit services opened from 2000. Lyndon Henry, Principal/Consultant, Mobility Planning Associates • Austin, Texas, 12 November 2012)



- LRT Substantial Installation

	Lowest	Highest
Location	St. Louis – Metrolink St. Clair Extension (2001)	Seattle – Link LRT South segment (2009)
Length	28.1 km	25.2 km
Cost	\$339.2 million	\$2.57 billion
Cost per Km	\$17.6 million/km	\$113.2 million/km
		



- LRT Minimal Installation

	Lowest	Highest
Location	Portland – Portland Streetcar (2001)	Phoenix - Metro (2008)
Length	3.9 km	31.6 km
Cost	\$56.9 million	\$1,400.0 million
Cost per Km	\$21.5 million/km	\$50.8 million/km
		

- BRT Substantial Installation

	Lowest	Highest
Location	Pittsburgh – West Busway (2000)	Boston – Silver Line Phase II/Piers Transitway/Waterfront tunnel (2003)
Length	9.0 km	1.6 km
Cost	\$419.2 million	\$790.3 million
Cost per Km	\$70.1 million/km	\$490.0 million/km
		

- BRT Minimal Installation

	Lowest	Highest
Location	Eugene, Oregon – Emerald Express (2007)	Cleveland – Health Line/Euclid Avenue (2008)
Length	4.0 km	7.1 km
Cost	\$24.6 million	\$197.2 million
Cost per Km	\$7.2 million/km	\$31.9 million/km
		

From the previous review it can be concluded that the suitable BRT and LRT system is the minimal installation type which be applicable in NBC. The recommended cost for BRT system is \$7.2 million/km (54 LE million/km) and LRT System is 21.5 million/km (161.25 LE million/km).

## Capital costs for NBC transport scenarios

Table 15 and Table 16 illustrate the capital cost for BRT and LRT systems within different scenarios developed in the framework of the ECO project for NBC based on the consultants experience in Egypt and the recommended cost based on the worldwide prices. There are no costs attached to biofuels and electric vehicles since the FS team doesn't have experts that can translate worldwide prices of such technologies to the Egyptian context.

*Table 15. Low Investment Sustainability scenario cost.*

Measures	Description	Consultant's Experience		Worldwide Prices	
		Cost Unit	Total Cost (Million LE)	Cost Unit	Total Cost (Million LE)
BRT Rapid Transit Network on the main roads of NBC	BRT systems, with average route length 99 Km covering NBC over 98 station.	3.2 Million LE Per Km	316.8	54 Million LE Per Km	5346
Pedestrian and Cycling Facilities	Pedestrian facilities include paths, sidewalks, crosswalks, walkways, stairs, ramps, and building entranceways. Cycling facilities, all roads should be considered cycling facilities (except where cycling is specifically prohibited). The cycling network should be a network of streets (a grid of 0.5 kilometers or less in urban areas) that ensure safe bicycle access to all popular destinations. Pedestrian and Cycling Facilities will cover NBC over length equal 200 Km.	25,000 LE Per Km	5.0	25,000 LE Per Km*	5.0
Calming Measures in city centers	Traffic calming measures are engineering tools used with the goal of reducing vehicle speed and improving the safety of motorists, pedestrians, and bicyclists. Four types of measures are recommended: Vertical deflections, horizontal shifts, and roadway narrowings are intended to reduce speed and enhance the street environment for non-motorists. Closures (diagonal diverters, half closures, full closures, and median barriers) are intended to reduce cut-through traffic by obstructing traffic movements in one or more directions.		0.5		0.5*
Parking Management system in city centers	Introduce a Parking Management system for access controls and customer management (such as for retail, residents and employees) as well as Park & Ride concepts for		1.5		1.5*

Measures	Description	Consultant's Experience		Worldwide Prices	
		Cost Unit	Total Cost (Million LE)	Cost Unit	Total Cost (Million LE)
	commuters turn the city into an inviting space.				
Biofuel/natural gas powered public transport					
Maintenance of vehicles to the manufacturer's specifications and applying for Vehicle Scrapping Programme					
Scenario Cost (Million LE)		323.8		5353.0	

\* Based on the consultant's experience.

Table 16. High Investment Sustainability scenario cost.

Measures	Description	Consultants Experience		Worldwide Prices	
		Cost Unit	Total Cost (Million LE)	Cost Unit	Total Cost (Million LE)
Bus Rapid Transit Network on the main roads of NBC	BRT systems, with average route length 55 Km covering NBC over 55 station.	3.2 Million LE Per Km	176	54 Million LE Per Km	2970
Light Rail Transit Network on the main roads of NBC	Light Rail Transit, with average route length 102 Km covering NBC over 83 station.	7.5 Million LE Per Km	765	161.25 Million LE Per Km	16447.5
New Regional Railway connecting with Alexandria City	New Regional Railway with average route length 60 Km.	11.0 Million LE Per Km	660	11.0 Million LE Per Km*	660*
Implement Intelligent Traffic System	The intelligent traffic system is implemented using road side units (RSU) with friction monitoring, vehicles with environmental sensors and a database for data transfer through different platforms.				
Implement freight transport centers	Implement three Freight transport centers include classification yards and truck terminals where passengers and cargo are exchanged between vehicles or between transport modes.	50.0 Million LE Per Center	150	50.0 Million LE Per Center*	150*

Measures	Description	Consultants Experience		Worldwide Prices	
		Cost Unit	Total Cost (Million LE)	Cost Unit	Total Cost (Million LE)
Pedestrian and Cycling Facilities	Pedestrian facilities include paths, sidewalks, crosswalks, walkways, stairs, ramps, and building entranceways. Cycling facilities, all roads should be considered cycling facilities (except where cycling is specifically prohibited). The cycling network should be a network of streets (a grid of 0.5 kilometers or less in urban areas) that ensure safe bicycle access to all popular destinations. Pedestrian and Cycling Facilities will cover NBC over length equal 200 Km.	25,000 LE Per Km	5	25,000 LE Per Km*	5*
Calming Measures in city centers	Traffic calming measures are engineering tools used with the goal of reducing vehicle speed and improving the safety of motorists, pedestrians, and bicyclists. Four types of measures are recommended: Vertical deflections, horizontal shifts, and roadway narrowings are intended to reduce speed and enhance the street environment for non-motorists. Closures (diagonal diverters, half closures, full closures, and median barriers) are intended to reduce cut-through traffic by obstructing traffic movements in one or more directions.		0.5		0.5*
Parking Management system in city centers	Introduce a Parking Management system for access controls and customer management (such as for retail, residents and employees) as well as Park & Ride concepts for commuters turn the city into an inviting space.		1.5		1.5*
Biofuel/natural gas powered public transport					
Maintenance of vehicles to the manufacturer's specifications and applying for Vehicle Scrapping Programme					
Scenario Cost (Million LE)		1758.0		20234.5	

\* Based on the consultant's experience.

## 8 Engagement of stakeholders

To engage stakeholders outside of the project consortium, workshops were arranged. The aim was to present the scenarios developed within the consortium and get a fresh view on those and feedback on them.

Stakeholders representing the following institutions were taking part in the workshops:

- Environmental department
- Alex Businessmen Association
- Holding Company of Petrochemical
- Technology of Plastic Industry Center
- Small Business Modernization Center
- Alexandria Cement Company
- Consultancy Center
- CRTA
- Chemical Department
- Ministry of Housing
- A.N.R.P.C
- Social Fund of Development
- ASC
- IGSR
- CRTA City
- Cairo University
- Egyptian Building Council
- NBC Investors Association

### 8.1 Challenges and opportunities of eco-cities from investors point of view

Egypt is a typical example of a developing country which is highly vulnerable to climate change and which faces numerous threats to its economic, social and environmental sustainability. This causes enormous fundamental pressures on Egypt's competitiveness. These pressures can also be described as growing threats to national security. They are fueled by a growing population and growing demand coupled with the constraints of a finite resource base and could develop into genuine crisis situations if not quickly and decisively addressed. These pressures include:

- Energy Security

Unsustainable use of energy resources is one of the major reasons for environmental degradation and climate change. The consequence is energy scarcity and rising energy prices which increase poverty, strain national budgets and jeopardize Egypt's competitiveness for the future.



- Water Security

Global-warming results in sea-level rise due to the melting of glaciers and arctic ice. Consequently, the world's fresh water resources decline while salt water intrudes into underground reservoirs. Egypt is particularly susceptible due to its low-altitude Nile Delta.

- Food Security

Limited water and agricultural land coupled with population growth and other factors are creating mounting pressure on Egypt's ability to provide food for its people in the future.

- Climate Change

Declining precipitation levels, changing weather patterns, and rising seas in the Nile Delta are slowly but steadily making a difficult situation worse, especially in the area of food and water.

- The Need for Jobs

Egypt's young population is hungry for work, and Egypt needs to generate over one million new jobs every year for its growing workforce.

Companies are very much affected by the scarcity of available resources and they cannot survive in the future if they cannot predict and adapt to major trends like climate change.

### 8.1.1 Challenges

- Lack of funding

Amid the political turmoil, economic growth remains weak in Egypt with a high fiscal deficit and gross public debt (domestic and external) rising to nearly 100% of GDP at the end of June 2013. Low growth rates posed the danger of fuelling social frustration as they could not deliver the numbers of jobs and opportunities needed. Unemployment reached over 13% in June 2013. Critically, more than three-quarters of the unemployed are between 15 and 29 years of age (World Bank, 2014). Under these difficult economic circumstances, lack of funding of national projects is becoming a major problem for Egypt.

- Lost capital investment (into non-green assets)

One of main capital investment sector in Egypt during the last few years was the real estates. Thousands of buildings were constructed in the course of the last three years without official licence. Unfortunately, the main purpose behind establishing these buildings was fast financial profit, and they hardly comply with any environmental rules. These are best examples of loss of capital investment into non-green assets. The National (June 2014) has written about Alexandria: "They can tell stories of a once-multicultural city that was considered a jewel of the Mediterranean until it gradually degraded into the overpopulated, anarchic cement sprawl of budget holiday flats, slums, cement high-rises, exposed sewers, regular power cuts and – since the 2011 Revolution – 27,000 new buildings, the majority of them illegal".

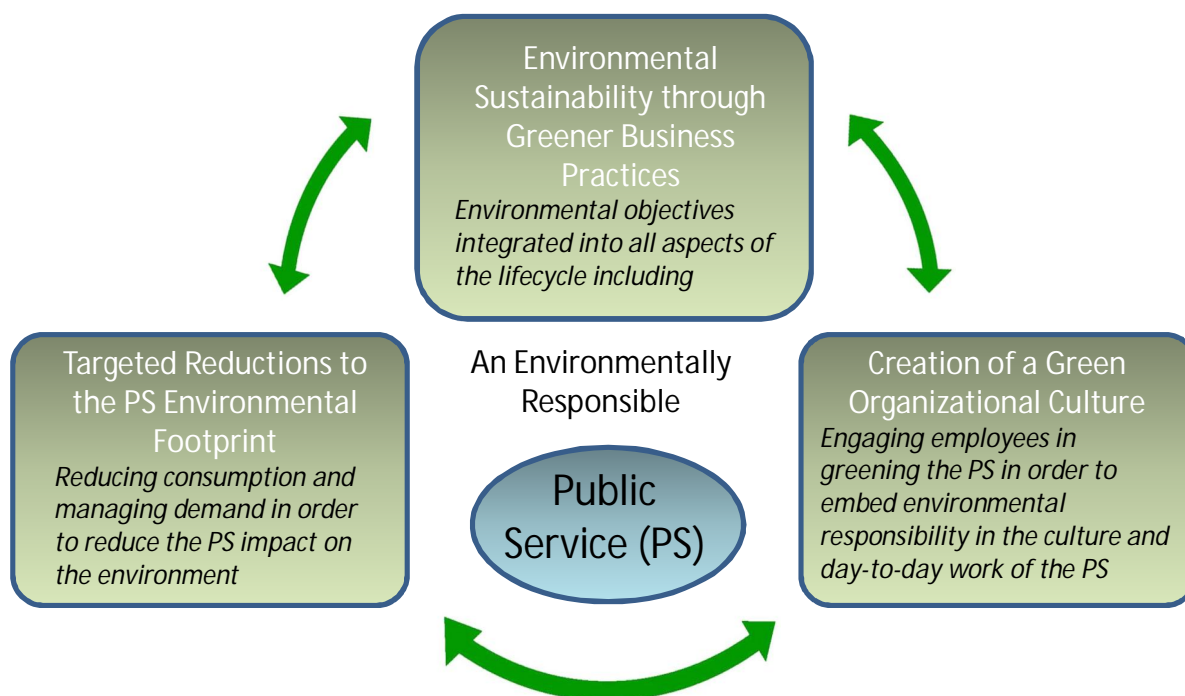

Figure 27. Green Transformation Strategy (OPS 2011) with modification.

- The non-existing strategy for Green Transformation

The existence of a strategy for green transformation is of prime importance. The main pillar of which should be Environmental Sustainability through Greener Business Practices. This again will be based on the creation of Green Organizational Culture and targeted reduction of the Environmental Footprints, which includes Reducing consumption and managing demand in order to reduce the Public Sector (PS) impact on the environment as seen in Figure 27. In other words, the green transformation has to be incorporated in all the country's development plans

- Lack of collaboration between private and public sector

Since the nationalization of the industries corporations in Nasser's time, the public industrial sector has been deteriorating. At the end it turns to be a burden on the State economy in view of its heavy losses. Unfortunately, the privatisation policy followed in Mubarak's time was full of corruption causing more losses to the public sectors and to the State. Currently the private sector has become fairly weak in Egypt, particularly as the Armed Forces are taking now responsibility of several civilian projects. Collaboration between the private sector and the public sector which lead to strengthening the private sector and increasing the efficiency of the operation of the public sector will have positive impact on the economy of Egypt particularly as the private sector is now widely acknowledged as a key partner in development, including through establishing new enterprises, creating jobs, providing goods and services, generating income and profits, and contributing to public revenues, which are critical to increasing countries' self-reliance and sustainable growth.

- None existing of effective incentives, penalties and forms of private-public-partnership (PPP) regarding the implementation of eco-cities

The implantation of EcoCities is an example where the partnership between the private and public sectors is very much needed. In addition to the environmental sustainability concerns, the financial viability of the project, cultural considerations, community needs, capacity for future maintenance of the city, and the availability of a suitable regulatory and administrative framework for the administration of the city, are important considerations. National and international incentives should be thought for successful PPP in EcoCities, as it might be difficult to adopt one model for such partnership.

- Lack of support towards the private sector in their adaptation measures

One of the biggest challenges for the private sector in the near future in Egypt will be surviving with the policy of eliminating the energy subsidies in the next five years. Some industrial establishments have already bankrupted, and brick industry has threatened to close its doors. Several support measures should be carefully considered including tax alleviation, incentives to use renewable energy, etc. This together with identifying a common policy by the Government in facing the current problems and providing support to private sector in their adaptation measures are current milestones for the private sector.

- Local administration performance

This is characterized in Egypt by complicated and lengthy procedures, conflicting functions, widespread manifestations of corruption and low efficiency of local administration employees. It important in any future country policy to address these problems and decrease the bureaucracy, of which Egypt is famous, and eliminate time and energy waste by Governmental employees as well as the natives of Egypt.

- Lack of integrated development approach

An integrated approach to development and policymaking will assist policymakers to avoid solving one problem while creating another. It will also contribute to a society's multiple objectives – including social, economic and environmental ones. This approach places sustainability considerations and policy assessment within the overall policymaking cycle, thereby making sustainability an integral part — rather than an “add-on”— to any such process. This approach suggests using sustainable development as a major filter for prioritizing competing issues and for formulating and deciding on policy choices while emphasizing a culture of learning, monitoring and evaluation alongside involving stakeholders and managing their dynamics at every stage (UNEP, 2008).

### 8.1.2 Opportunities

Egypt is one of the Sun Belt countries that enjoy one of the largest potentials of solar energy, the sunshine duration ranges between 9–11 h per day from North to South with very few cloudy days. Starting to build Solar Power Stations will be one of the sustainable, fast and economic solutions to cope with blackouts, which happen mainly in summer, contribute to solve the problem of unemployment. In addition, Solar PV Power plants could be built in unites each one, e.g., 100 MW and could be commissioned in few weeks/months.

The increase in the percentage of youth in the population is a positive indicator of human resource, raising the challenge of providing the suitable environment for their education, training and employment. The big share of young people gives an opportunity to wide awareness-raising about environmental matters through schools and higher education programs. This enables a big part of the population to be highly aware of environmental issues within a rather short time frame.

Solid waste management has the potential to contribute to reduced landfill demand, reductions in green-house gases, produce renewable energy, lower terrestrial and aquatic pollution levels, improve public health, and reduced energy use in the transport and disposal of wastes. Recycling and reuse of wastes has the potential to create jobs and reduce dependence on material import for production. Waste management challenges in cities are amplified by high rates of urbanization.

## 9 Pioneering examples

### 9.1 Textile industry case study

This case example presents the treatment of reactive dyes wastewater in down flow hanging sponge (DHS) system at a pilot scale.

#### 9.1.1 Introduction

Reactive dyes, in particular, are used by the majority of the industries in NBC for coloring different materials. Apart from inducing color to the receiving stream of water, many synthetic dyes are potentially toxic as well as carcinogenic (You et al., 2010). Synthetic dyes present in wastewater would destroy the natural quality of water environment and also cause detrimental long-term health and environmental effects (Forgacs et al., 2004). Therefore, the removal of color from dyestuff manufacturing industry wastewaters represents a major environmental concern. Moreover, reuse of the effluents represents an economic and ecological challenge for the entire sector. The aim of this study is to assess the efficiency of down-flow hanging sponge system at a pilot scale for decolorization of reactive dyes wastewater supplemented with 1 mg/l cationic polymer at different hydraulic retention times (HRTs) and organic loading rates (OLRs). Moreover, the effect of salinity on the removal of COD, BOD<sub>5</sub> and color was investigated. The mechanism removal of color along DHS system height was also performed.

#### 9.1.2 Material and Methods

Reactive dyes wastewater was collected from a textile factory situated in Borg El Arab city, Egypt. The composition of reactive dyes wastewater varied widely due to the variety of recipes, techniques, machinery, raw materials, and fabrics used in the production processes of the factory. The wastewater was fed to Down-flow hanging sponge (DHS) system (Figure 28) and operated at different flow rates, HRTs and OLRs. The DHS system was equipped with effective volume of the sponge (3.6 l).

#### 9.1.3 Results and discussion

This study was carried out to investigate, the color removal from reactive dyes wastewater supplemented with 1 mg/l cationic polymer (Organo Pol.) in down flow hanging sponge (DHS) system. The reactor was operated at different hydraulic retention times (HRTs) of 1.7, 2.3, 3.5, 5 and 6.0 h., corresponding to organic loading rates (OLRs) of 12.44, 7.7, 5.6, 2.8 and 2.35 g COD/l. d. At HRT of 5 h and OLR not exceeding 2.8 g COD/l. d., the reactor achieved removal efficiencies of  $66.5 \pm 7.07\%$  for COD t,  $31.5 \pm 10$  for CODs;  $96 \pm 1.5\%$  for COD p and  $90.12 \pm 3.13\%$  for color (Figure 31, Figure 32, etc.). TSS and turbidity removal efficiencies amounted to  $87 \pm 5.8$  and  $94.5 \pm 3\%$  respectively. The results revealed that, the removal efficiencies of the DHS system in terms of COD fractions was significantly dropped at higher and lower OLRs of 12.44 and 2.35 g COD/l. d respectively. Nevertheless, the reactor achieved a color, TSS and turbidity removal

efficiencies of  $76.2 \pm 7.6$ ,  $83 \pm 6.5$  and  $92.2 \pm 3.2\%$  respectively at a HRT of 6.0 h and OLR of 2.35 g COD/l. d. At the latter conditions adsorption process was the main removal mechanism and biodegradation process was minor due to a high salinity of  $17.9 \pm 0.36$  g/l in the influent wastewater. Besides high efficiency of dye removal, the DHS system offers many advantages for potential application such as minimal amount of sludge production (0.36 g TS/d) and also economically feasible since it does not require high costs for aeration, and equipment. Moreover, the results indicated that decolorization of reactive dyes wastewater in DHS system was feasible with the supplementation of 1 mg/l cationic polymer at OLR not exceeding 2.8 g COD/l. d., and HRT of 5 h.

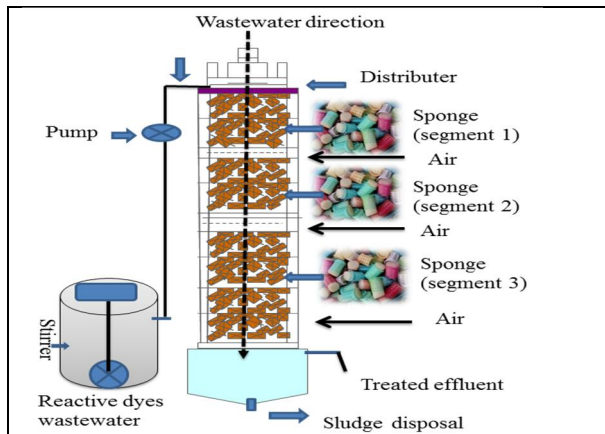

Figure 28. DHS system treating reactive dyes wastewater. (Dr. Ahmed Tawfik, E-JUST)

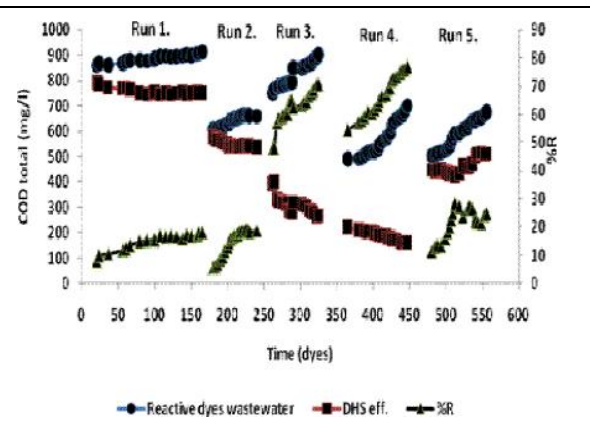

Figure 29. Time course of COD total removal efficiencies at different HRT. (Dr. Ahmed Tawfik, E-JUST)

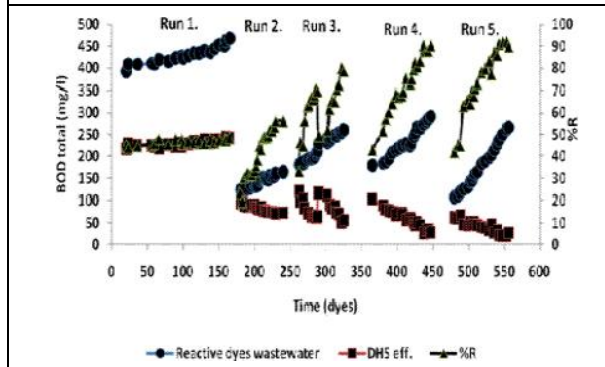

Figure 30. Time course of BOD5 total removal efficiencies at different HRT. (Dr. Ahmed Tawfik, E-JUST)

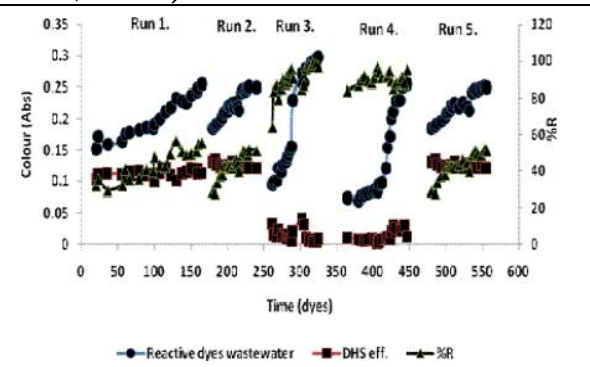

Figure 31. Time course of color removal efficiencies at different HRT. (Dr. Ahmed Tawfik, E-JUST)

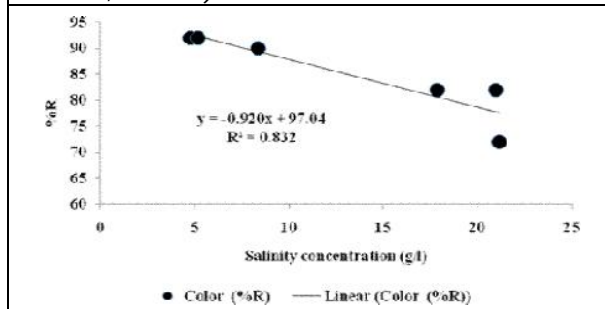

Figure 32. Effect of salinity concentration on the color removal. (Dr. Ahmed Tawfik, E-JUST)

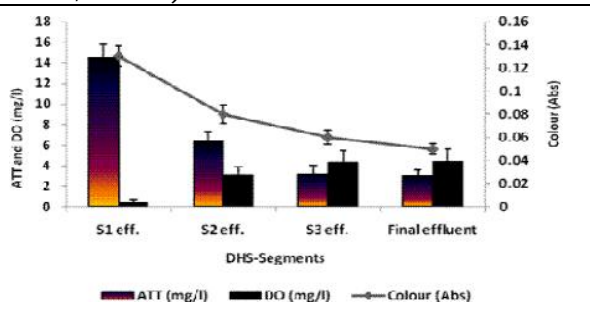

Figure 33. ATT; DO and color removal along the height of DHS system. (Dr. Ahmed Tawfik, E-JUST)

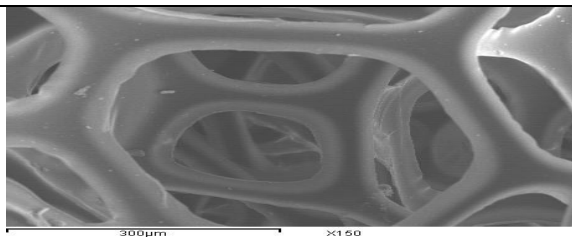

Figure 34. The clean sponge prior starting the experiments. (Dr. Ahmed Tawfik, E-JUST)

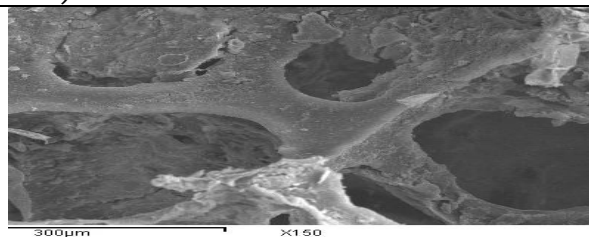

Figure 35. The densely attached biomass in the polyurethane foam pores. (Dr. Ahmed Tawfik, E-JUST)



## 9.2 Paper industry case study

This case example presents hydrogen production from paperboard mill wastewater.

### 9.2.1 Introduction

Production of biofuels from wastewater has emerged as a realistic possibility to reduce fossil fuel use (Dqg et al., 2011). Paperboard mill is one of the most polluting industries in Egypt since it requires a large amount of water for its operation, and discharges considerable quantities of wastewater (Leaño & Babel, 2012). This can cause considerable environmental problems if discharged without effective treatment by polluting land, water, and destroying aquatic life (Ahmad et al., 2011). It has been identified that the paperboard mill effluent is considered a potential source to generate renewable bio-energies through anaerobic digestion. That's because the PBE contains plentiful cellulosic concentrations which makes anaerobic digestion a favorable waste treatment technique (Chen et al., 2008), at the same time, it is could be feasibly utilized for H<sub>2</sub> production for further using as an energy source (Chairattanamanokorn et al., 2012). Earlier studies indicate that paperboard mill wastewater will not only provide the energy source but also solve the wastewater treatment problems (Lay et al., 2013). Therefore, a novel method for converting paperboard wastewater into environmentally friendly fuels aside with industrial wastewater treatment strategy is greatly desired.

### 9.2.2 Material and methods

Paperboard wastewater (PBW) was collected from Aldar Albydaa factory (NBC, Egypt). Printing paper and plastics wastes is used for manufacturing of paperboard. The factory consumes 60 ton/d., raw material and generates 700 m<sup>3</sup>/d., wastewater. The end of pipe effluent was sampled and transferred to the environmental lab for experiments. COD particulate and COD soluble represented 67.31% and 32.69% of the total COD, respectively. The VSS/TSS ratio of the wastewater is 0.44. Likely, the C/N ratio was found to be 38.97 which is considered optimal condition for H<sub>2</sub> production. The concentration of total carbohydrates was 51.90 mg/L. The batch tests were performed to optimize the Tween 80 and Polyethylene glycol 6000 concentrations for higher hydrogen generation utilizing the paperboard mill effluent. Different mixtures between the substrate and these surfactants inoculated with heat-treated sludge have been conducted in serum bottles with working volume of 400 mL. Anaerobic conditions were created in the bottles by nitrogen gas sparging. The bottles were maintained at a constant temperature of 65 °C to simulate the real situation where the end of pipe effluent temperature exceeds 60 °C and a pH of 7.0. Control samples were prepared in parallel without no addition of surfactants. The duration of the experiments was 3 days for all mixtures. The bottles were capped tightly with rubber stoppers and aluminum crimp seals. Two types of surfactants were used in this investigation 1. Tween 80 in mL (PolyoxyethyleneSorbitan L332090 Mono-Oleate, water ≤ 3.0%, Density 1.08, RTECS #7WG2932500, EINECS 215-665-4 TSCA, ROTH Bestellen Siezum, Germany) and 2. Polyethylene glycol 6000 in mg/L (MW 5600-7000, H(OCH<sub>2</sub>CH<sub>2</sub>)<sub>n</sub>OH, RTECS #ZD2465300, EINECS 200-849-9 TSCA, Kentucky 40361, Paris).



### 9.2.3 Results and discussion

Three sets of batch experiments were conducted to investigate the effect of addition of surfactants on the hydrogen production from paperboard mill wastewater (Table 17). The best response was recorded for hydrogen production with Polyethylene Glycol 6000 addition where the hydrogen yield amounted (61.85 mL/gCOD) and the maximum hydrogen production was 130.9 mL which was 1.85 fold of that produced from the control samples. Moreover, about 68.29% of total COD has been removed using PEG compared to 46.30% using Tween 80 achieving 140.58% and 63.11% higher than that removed without any surfactants, respectively (Figure 36 and Figure 37). The main soluble products were acetic acid, butyric acid, lactic acid, and propionic acid for all mixtures. The paperboard mill wastewater could be tapped as one of the potential sources of renewable organic matter source to produce hydrogen.

Table 17. The kinetic parameters of hydrogen production from various mixtures. (Dr. Ahmed Tawfik and Ahmed Farghaly, E-JUST)

No.	Case	Sample label	P (mL H <sub>2</sub> )	R <sub>m</sub> (ml H <sub>2</sub> /h)	λ (h)	R <sup>2</sup>
1	Control	S	57.86	6.59	12.00	0.97
2		S+AS	70.80	7.00	10.00	0.99
3	Tween 80	1 T	80.16	7.50	12.00	0.98
4		3 T	98.75	8.73	11.00	0.99
5		5 T	104.30	9.07	8.00	0.99
6		7 T	121.25	12.07	10.00	0.99
7		10 T	94.75	9.50	11.00	0.96
8	Polyethylene Glycol 6000	1 PEG	117.60	8.57	8.00	0.97
9		3 PEG	130.93	11.87	6.00	0.98
10		5 PEG	88.40	7.33	6.00	0.99
11		7 PEG	87.40	8.87	6.00	0.98
12		10 PEG	87.10	9.27	10.00	0.99

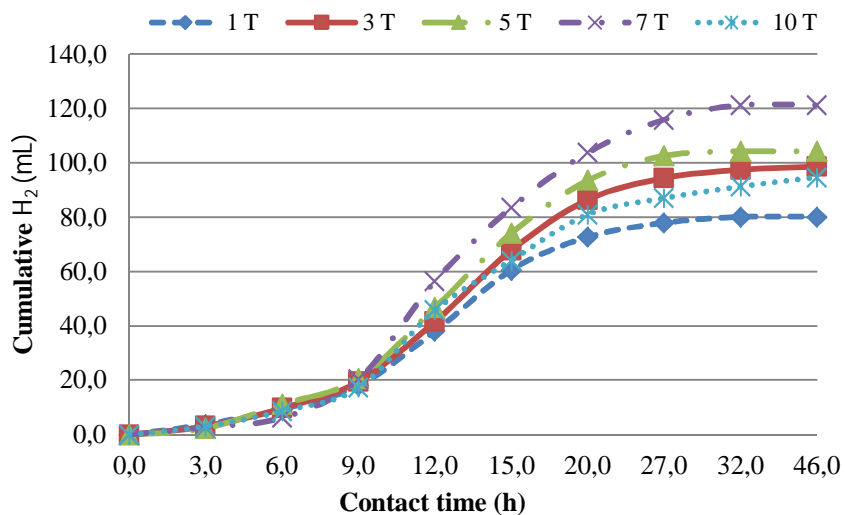

Figure 36. Effect of Tween 80 addition on the cumulative hydrogen (mL) from paper board wastewater. (Dr. Ahmed Tawfik and Ahmed Farghaly, E-JUST)

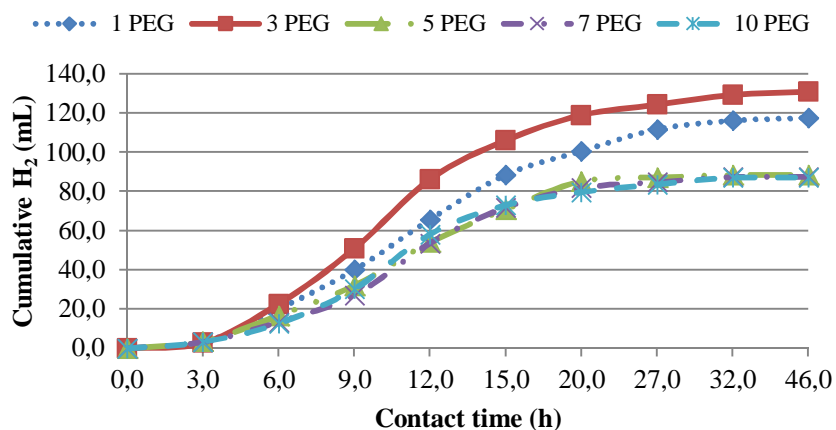

Figure 37. Effect of polyethylene glycol (PEG) addition on the cumulative hydrogen (mL) from paper board wastewater. (Dr. Ahmed Tawfik and Ahmed Farghaly, E-JUST)

### 9.3 International examples

There are many good examples of EcoCity developments in different parts of the world. Europe has been a fore runner in this aspect, there are some cities in Europe that have already for decades had eco-efficiency as a main objective in their urban planning processes. One of these is Freiburg in Germany which will be presented below. Vancouver, Canada is one of North America's best examples of ecological urban planning and is also presented below. The Finnish case Viikki in Helsinki is described also presenting a district where ecology has been the core in planning for decades.

### 9.3.1 Freiburg, Germany

Freiburg was founded in 1120. It has approximately 230 000 inhabitants. The city is a university city with no major industry facilities. In Freiburg sustainable development has been a leading theme in the city planning since the 80's. The planning team consists of people from different areas: energy, traffic, waste & water, park-division. These different experts work together throughout the whole planning process. The overall objective of a district is always decided first: energy-efficiency/car-free/densely built, etc. Involving inhabitants in the planning process is valued very highly. One concrete way to do this has been to let inhabitants plan common spaces themselves (Daseking, 2009).

Over a decade ago a principle decision was made not to allow big markets outside the centre. This decision was done to ensure services in the city centre and to reduce the dependency of cars (Daseking, 2009). Many studies show that big service centres outside city canter damages the city centre in terms of services. Freiburg was a forerunner in making such a strategic decision. It has later been followed also in other parts of Europe.

On the outskirts of Freiburg in the mountains, there is a wind farm, which is visible all over the city. There is a district heating plant which has a metering system which visualizes the energy produced and the emissions created. Also comparing information to "basic plants" is shown.

Vauban is one residential area which has many ecological aspects. When starting the planning, the general objective was to create a car free district. There is a parking garage in the outskirt of the district with solar panels on the roof. Within the district you can move easily with the tram. Important to note is that the tramline was built before the houses, this to ensure that when the residents move in, they already have functioning public transportation available. The tramlines have a "noise prevention" solution carried out in a very easy way, by having grass under the lines which absorbs the noise. Overall noise level is very low in Vauban due to the absence of cars (Daseking, 2009). 85/1000 inhabitants in Vauban owns a car.

The houses in the Vauban area are all very energy efficient. This achieved by good insulation, good windows and doors, heat recovery units in ventilation systems and architectonic solutions keeping solar heat out in the summer. It is common to see solar panels and solar heaters on the roofs of the buildings.



*Figure 38. Tramline with grass lowering the noise level. (Åsa Hedman, VTT)*



*Figure 39. Residential houses in Vauban with solar shading solution integrated in the architectonics of the houses. (Åsa Hedman, VTT)*

The building lots were sold one-by-one, not bloc-by-block to construction companies like is often done (Daseking, 2009). This together with the principle of giving rather free hands with the visual architectonic designs of houses has led to a nice end result with houses looking different from each other and creating a “lively” impression. Through the district there is a small river and a green area where people can feel the closeness of nature while at the same time being very close to the city centre and having most daily services available within their own district.

### 9.3.2 Vancouver, Canada

Vancouver is a 600 000 inhabitants city in Western Canada. The city's target is to become the greenest city in the world by 2020. To achieve this ambitious target the city staff are working with Council, residents, businesses, other organizations, and all levels of government to implement the Greenest City 2020 Action Plan. The Action Plan is

divided into ten goal areas, each with a specific 2020 target. Together, these address three overarching areas of focus: Carbon, Waste and Ecosystems.

In the 1990's Vancouver's City Council embarked on a comprehensive planning initiative called CityPlan. Through CityPlan, Vancouver residents and City Council agreed on these directions for the city's future:

- Strengthen neighbourhood centres
- Improve safety and ensure appropriate community services
- Reduce reliance on the car
- Improving environmental sustainability
- Increase the variety and affordability of housing
- Define neighbourhood character
- Diversify parks and public places
- Involve people in decisions affecting their neighbourhood

As part of this process, it was recognized that CityPlan could only be truly effective if it was 'scaled' to the neighbourhood level. Vancouver is focusing on green building design and construction. Council's environmental regulations for new buildings are some of the greenest of any city in North America. Guidelines, standards, and polices have been developed in Vancouver that contribute to further improvements in energy efficiency, including: passive design guidelines, electric vehicle recharging requirements and guidelines for water wise landscapes.

Regarding electric vehicle recharging requirements, the city council have updated building bylaws to include mandatory charging infrastructure for multi-family homes. To accommodate electrical vehicles in new apartment buildings, condos, townhouses, and other buildings with a minimum of three homes, Council has made the following revisions to the City's building bylaw:

- Parking stalls – 20% of the parking stalls in every building must include a receptacle for charging cars.
- Electrical room – The electrical room must include enough space to install any equipment necessary to provide charging for all residents in the future.

While supporting EVs in new buildings is important, the City is also supporting early adopters who live and work in existing buildings that have no access to electric outlets. Guidelines for installing EV charging infrastructure are being developed. Guidelines shall offer information on costs and charging technology options, so that building managers, strata councils, and fleet managers can understand the implications of providing EV charging. The City will also facilitate the development permitting process for retrofitting buildings to include charging infrastructure.

Regarding water wise landscapes, the city has developed guidelines to help developers and designers create high efficiency homes, offices, and public facilities.

EcoCity green re-zoning policies, passed by the Council in 2008 as the EcoDensity Charter and Initial Actions, established a re-zoning policy to achieve higher sustainability standards as an essential part of large site developments. All re-zonings that involve 2 acres or more of land must include plans or studies in six areas:

1. District energy screening and feasibility
2. Sustainable site design
3. Green mobility and clean vehicles
4. Rainwater management
5. Solid waste diversion
6. Sustainable housing affordability and housing mix

Source: Vancouver.ca

### 9.3.3 Viikki, Finland

Viikki is situated in the eastern part of Helsinki, Finland. In Viikki ecological aspects have been the core of planning ever since the early 90's. The development has been consistent in terms of setting ecological values in focus, beginning from strategic planning to detailed project planning, implementation and follow up.

The Eco-Viikki district was built between 2000 and 2004. Around 2000 people live in Eco-Viikki. A criteria setting to support ecological construction was developed for the construction of the district. A wide range of aspects were taken into account including: emissions, use of natural resources, healthy constructions and the diversity of nature, efficient use of energy, water and material were essential parts of the criteria. The ecological criteria had to be met in order to receive the right to build.

One target that was set by the City of Helsinki, was to reduce the net heating consumption with 60–65% compared to the “business as usual” level at the time. Three different solar energy demonstration projects were realized in the area. One is a district solar heating system that provides solar heating for 370 dwellings. Solar electricity is demonstrated in one high rise building where the target was to produce 20% of the household electricity with PV panels installed on the balconies. The district also has a focus on locally produced food. Many garden lots can be found where food is grown, which is a special challenge in the cold Finnish climate.

One part of the requirements was to allow measurements of the performance of the residential buildings, schools and day-care centres in terms of heating, electricity and water usage. Measurements have shown that these targets were not fully reached, mainly due to lots of new technologies being used in a non-optimized way. The targets for electricity and water usage were mainly reached.

Source:

[http://www.hel.fi/hel2/taske/julkaisut/2009/EkoViikki\\_raportti\\_Motiva%202008.pdf](http://www.hel.fi/hel2/taske/julkaisut/2009/EkoViikki_raportti_Motiva%202008.pdf)

## 10 Benefits and barriers

The cornerstone of the design of the city is the exploitation of latest state-of-art energy efficiency and renewable technologies in all sectors, for electricity and heat generation, always adapted to the local context. The project will also urge best practices in waste management and transportation planning focusing on modal shift and technologies and demand management. Additional emissions savings are expected from the following sectors: agriculture, wastewater management, carbon sequestration through trees planting in the green belt surrounding the city.

There are numerous benefits for undertaking the FS, and hence transferring NBC into an EcoCity. First, for E-JUST staff and students, the transferring process itself will provide endless research topics to the staff and students. The work on FS together with the other activities of the project as WS, Seminars, ST, etc., will enhance the knowledge and experience of the staff of E-JUST about EcoCities. This would increase cooperation possibilities between E-JUST and other national, regional and international Universities and Research Institutes. Thanks to the growing experience of staff in the different sectors, E-JUST will develop a bank of expertise on EcoCity aspects serving similar projects and cities in Egypt and possibly in neighbour Arab Countries.

Second, industry and commercial sectors are going to enjoy the outcomes of transferring NBC into an EcoCity. More efficient use of energy and possible utilization of renewable energy as in solar heating, air-conditioning and biogas would considerably decrease their energy bill, hence increase profitability. On the other hand, improving the living conditions and transportation means in and to NBC will encourage their employee to live in the City and save time and money in transportation.

Third, the inhabitants of NBC will enjoy living an ecologically friendly and safe environment, with clean potable water, adequate liquid and solid waste recycling/management, energy efficient building and equipments and clean and convenient transportation system.

Fourth, on the country scale, the project has also a huge potential for replication. Besides, the technical tools and the regulatory framework as well as financial incentives to be developed under the proposed project will all contribute to boost energy efficiency and renewable energy technologies market in Egypt and the region. In addition, the global environmental benefits will result from the successful implementation of the tools

developed and investments in clean energy technologies at both demand side and supply side (EE&RE).

On the other hand there are several barriers that would be encountered before arriving at these benefits. First of all, Egypt faces serious challenges in attracting private investments in clean energy technologies. There are several reasons for this as well as possible solutions. First, fossil fuel subsidies are twisting the energy economy of the country making it difficult to invest in EE&RE projects. A national energy strategy is required to lift fossil fuel subsidies and provide incentives for EE&RE projects. In this connection, awareness raising campaigns targeted at decision makers are badly needed.

On the other hand, dedicated sources of financing for energy efficiency are lacking. This requires the creation of opportunities for industrial facilities and business enterprises to invest in energy efficiency and renewable energy projects through the development of demonstration projects for these clean technologies in order to gain more experience and to increase confidence in this emerging technology.

Second, local experts lack adequate knowledge and experience in identifying and formulating energy efficiency investment project proposals. There is a need to develop skills in the private and public sectors at the local level to identify, formulate and implement energy efficiency and renewable energy investment in selected proven technologies. Hence, training courses and workshops are thus needed for professionals to raise awareness and to overcome the current lack of expertise amongst professionals (planners, installer, etc.). Also developing planning guidelines to promote EE&RE by assisting planners is also recommended.

Third, in the absence of policy and institutional support, private investors are not motivated to finance energy efficiency projects. This requires specific assistance to municipal authorities and national Governments to introduce reforms needed to support these investments.



## 11 References

- Ahmad, A., Ghufuran, R., Wahid, Z. A. 2011. *Bioenergy from anaerobic degradation of lipids in palm oil mill effluent*. Reviews in Environmental Science and Bio/Technology, vol. 10, no. 4, pages 353–376, Oct. 2011.
- Chairattananamokorn, P., Tapananont, S., Detjaroen, S., Sangkhatim, J., Anurakpongsatorn, P., Sirirote, P. 2012. *Additional paper waste in pulping sludge for biohydrogen production by heat-shocked sludge*. Applied biochemistry and biotechnology, vol. 166, no. 2, pages 389–401, Jan. 2012.
- Chen, Y., Cheng, J. J., Creamer, K. S. 2008. *Inhibition of anaerobic digestion process: a review*. Bioresource technology, vol. 99, no. 10, pages 4044–64, Jul. 2008.
- Daseking, W. 2009. *Interview by Åsa Hedman*. Freiburg, Germany, May 2009
- Dqg, D. I., Lrpdvv, R., Sveinsdottir, M., Sigurbjornsdottir, M. A., Orlygsson, J. 2011. WKDQRO DQG + \GURJHQ 3URGXFWLRO ZLWK 7KHUPRSKLOLF, 2011.
- EIA (Energy Information Administration). 2013. *Country analysis brief: Egypt*.
- Eurostat. 2014. *Energy price statistics*. European Commission, Luxembourg. Available at [http://epp.eurostat.ec.europa.eu/statistics\\_explained/index.php/energy\\_price\\_statistics](http://epp.eurostat.ec.europa.eu/statistics_explained/index.php/energy_price_statistics)
- Farghaly, A., Tawfik, A., Gamal Eldin Ibrahim, M. 2015. *Surfactant-supplemented mixed bacterial cultures to produce hydrogen from paperboard mill wastewater*. Eng. Life Sci., 00, 1–8, 2015.
- Forgacs, E., Cserhati, T., Oros, G. 2004. *Removal of synthetic dyes from wastewaters: a review*. Environ. Int. 30 (7), 953–971.
- Kalin, S. 2014. *Egypt raises electricity prices*. Reuters, London. Available at <http://af.reuters.com/article/investingNews//idAFKBN0F81KF20140703>
- Lay, C., Sen, B., Huang, S., Chen, C., Lin, C. 2013. *Sustainable bioenergy production from tofu-processing wastewater by anaerobic hydrogen fermentation for onsite energy recovery*. Renewable Energy, vol. 58, pages 60–67, 2013.
- Leaño, E. P., Babel, S. 2012. *The influence of enzyme and surfactant on biohydrogen production and electricity generation using Palm Oil Mill Effluent*. Journal of Cleaner Production, vol. 31, pages 91–99, Aug. 2012.
- Oil and Gas Journal. 2012. Vol. 110, issue 12 C, Dec. 2012.

- Razavi, H. 2012. *Clean energy development in Egypt*. African Development Bank, 2012.
- Reda, F., Tuominen, P., Hedman, Å., Gamal Eldin Ibrahim, M. 2015. *Low-energy residential buildings in New Borg El Arab: Simulation and survey based energy assessment*. Energy and Buildings, Volume 93, 15 April 2015, pages 65–82, ISSN 0378-7788, <http://dx.doi.org/10.1016/j.enbuild.2015.02.021>
- Ryan, L., Campbell, N. 2012. *Spreading the Net: The Multiple Benefits of Energy Efficiency Improvements*. IEA: Insights Series 2012.
- Shahin, M., Hedman, Å. 2014. *Transportation planning a key element in EcoCity development. Analysis of scenarios for NewBorgElArab, Egypt*. European Conference on Transportation. Frankfurt, Germany, 30.9.–2.10.2014.
- Tawfik, A., Zaki, D. F., Zahran, M. K. 2014. *Degradation of reactive dyes wastewater supplemented with cationic polymer (Organo Pol.) in a down flow hanging sponge (DHS) system*. Journal of Industrial and Engineering Chemistry, vol. 20, issue 4, pages 2059–2065, 25 July 2014.
- Tuominen, P., Reda, F., Dawoud, W., Elboshy, B., Elshafei, G., Negm, A. 2015. *Economic appraisal of energy efficiency in buildins using Cost-Effectiveness Assessment*. Procedia Economics and Finance 21, 422-430, 2015.
- UNEP (United Nations Environment Programme). 2008. *Climate Change and Energy in the Mediterranean*. Sophia Antipolis, France, 2008.
- You, S., Damodar, R. A., Hou, S. 2010. *Degradation of Reactive Black 5 dye using anaerobic/aerobic membrane bioreactor (MBR) and photochemical membrane reactor*. Journal of Hazardous Materials 177, 1112–1118, 2010.

ANNEX 1: SUMMARY OF COMMERCIAL/PUBLIC FACILITIES SECTOR

DISTRICT	Status	Social Services				Administration services (Administration Building and the Annexations and other Buildings)	Security Services (Police, Fire Brigade, National Security and Traffic)	Commercial Services (Markets)	Education Services (Schools and Al-Azhar institutes)	Culture Services (Culture Centers)	Religious Services (Mosques)	Health Services (Hospitals, Health Centers and Health Insurance Cliniques)	Public Services (Bakery, Mail, Telegraph, Bus Station, Training Center)	Industrial Services (Services Building for Industrial Region)	Centrals	TOTAL
		Kindergarten	Occasions Hall	Sport Club	Youth Hostel											
First Neighbourhood	Done	Kindergarten						Basic Education School		Mosques					3	
Second Neighbourhood	Done							Experimental School	Culture Center						2	
Third Neighbourhood	Done	2 Kindergartens									Health Center	Bakery			4	
Fourth Neighbourhood	Done	Kindergarten				Traffic Administration Building	Market	Secondary Al-Azhar institutes							4	
Fifth Neighbourhood	Done	Kindergarten		Youth Center	Youth hostel		Police, Fire Brigade, National Security	Al-Azhar institutes			Public Hospital				8	
Sixth Neighbourhood	Done	2 Kindergartens						Secondary Education School							3	
Seventh Neighbourhood	Done	Kindergarten				Administration Building,		Basic Education School				Mail, Telegraph and Telephones			5	
Eighth Neighbourhood	Done	Kindergarten								Mosques	Health Insurance				3	
Ninth Neighbourhood	Done	Kindergarten	Occasions Hall			Endowments Building	El Baraka Market - El Suika Market	Basic Education School - Industrial Secondary School		Mosques	Health Center				9	
First Society	Done						Fire Brigade	Basic Education School							2	
Second Society	Done							El Thamany Market							1	
Third Society	Done														0	
Fourth Society	Done	Kindergarten													1	
Fifth Society	Done						Court Building								1	
Sixth Society	Done										Health Unit				1	
Seventh District	Done	Kindergarten						Market			Health Unit				3	
Central Axis	Done						Fire Brigade				Health Unit			Central	3	
Extension of Central Axis	Done						Police					Bus Station			2	
Industrial Regions	Done						2 Fire Brigades						Services Building		3	
First Industrial Regions	Done					Training center						Stores			2	
City Gate	Done					Parking Building - Agriculture Administration									2	
TOTAL		12	1	1	1	5	10	5	9	1	3	7	5	1	62	
NBC Masterplan		180	1	4			11		99	16	61	72				

ANNEX 2: VISION AND SCENARIOS FOR TURNING NBC INTO AN ECOCITY

1. VISION

Issues of concern	Sectors considered for the Feasibility Study					
	General	Residential	Commercial/Public facilities	Industrial	Services/Utilities	Transport
Energy	<p>Possibility to sell extra energy to the grid</p> <p>Solar water heating</p> <p>Solar air conditioning</p> <p>Waste to energy</p> <p>Increase public awareness</p> <p>Use of efficient lighting solutions</p> <p>Monitor and trace hazardous chemicals</p> <p>Smart use of energy (reduce peak consumption, energy storage, load matching, smart control)</p> <p>Energy efficiency</p> <p>Green policy for all</p> <p>Use of local materials</p> <p>Cleaner production (green industry)</p> <p>Enforcement of environmental laws and regulations</p> <p>Energy information and tips available (E-JUST Energy Office)</p> <p>ESCO companies</p> <p>Enforcement of traffic laws and regulations</p> <p>Use of biofuels</p> <p>Electric cars</p> <p>Electrification of railway connection between Borg El Arab City and Alexandria</p> <p>Pedestrian and bicycle lanes</p> <p>Improve bus system</p> <p>Supporting car pooling</p> <p>Introduce intelligent traffic systems, ITS</p> <p>Reduce use of private cars in city centres (parking fees)</p>	<p>Possibility to sell extra energy to the grid</p> <p>Local building energy code (including lighting)</p> <p>Solar water heating</p> <p>Solar air conditioning</p> <p>Waste to energy</p> <p>Increase public awareness</p> <p>Use of efficient lighting solutions</p> <p>Smart use of energy (reduce peak consumption, energy storage, load matching, smart control)</p> <p>Energy efficiency</p> <p>Use of local materials</p> <p>-----</p> <p>Targets:</p> <ul style="list-style-type: none"> <li>100% net renewable energy in all new buildings</li> <li>Reduce by 50% in 10 years the total energy consumption compared to business as usual</li> </ul>	<p>Solar water heating</p> <p>Solar air conditioning</p> <p>Waste to energy</p> <p>Increase public awareness</p> <p>Use of efficient lighting solutions</p> <p>Monitor and trace hazardous chemicals</p> <p>Smart use of energy (reduce peak consumption, energy storage, load matching, smart control)</p> <p>Energy efficiency</p> <p>Green policy for all</p> <p>Use of local materials</p> <p>-----</p> <p>Targets:</p> <ul style="list-style-type: none"> <li>Enforcement of existing law to close businesses at a given time</li> <li>Energy efficiency (efficient lighting, refrigeration)</li> </ul>	<p>Cleaner production (green industry)</p> <p>Monitoring (in-plant control)</p> <p>Maintaining the energy cycle</p> <p>Renewable energy</p> <p>Energy efficiency (ISO 50000, etc.)</p> <p>Increase public awareness</p> <p>Use of efficient lighting solutions</p> <p>Monitor and trace hazardous chemicals</p> <p>Possibility to sell extra energy to the grid</p> <p>Smart use of energy (reduce peak consumption, energy storage, load matching, smart control)</p> <p>Enforcement of environmental laws and regulations</p> <p>-----</p> <p>Targets:</p> <ul style="list-style-type: none"> <li>100% of industries energy audited on regular basis</li> <li>100% of industries having a green policy, self-monitoring and continuous improvement processes</li> <li>Shared responsibility in trade (hazardous chemicals)</li> <li>Upgrading of outdated equipment through enforcement and incentives</li> <li>Use of renewable energy (numerical target to be defined later)</li> </ul>	<p>Minimization of electricity consumption in public places</p> <p>Daily services within walking distance (around 500m)</p> <p>Use of efficient lighting solutions</p> <p>Increase public awareness</p> <p>Smart use of energy (reduce peak consumption, energy storage, load matching, smart control)</p> <p>Providing consultancy on energy efficient solutions</p> <p>Providing energy audit service (E-JUST Energy Office)</p> <p>Energy information and tips available (E-JUST Energy Office)</p> <p>ESCO companies</p> <p>-----</p> <p>Targets:</p> <ul style="list-style-type: none"> <li>60% reduction of energy consumption in Government offices compared to business as usual</li> <li>E-JUST Energy Office is up and running in the near future</li> </ul>	<p>Use of biofuels</p> <p>Electric cars</p> <p>Fuel cells</p> <p>Electrification of railway connection between Borg El Arab City and Alexandria</p> <p>Pedestrian and bicycle lanes</p> <p>Improve bus system</p> <p>Busycle</p> <p>Supporting car pooling</p> <p>Increase public awareness</p> <p>Energy efficiency</p> <p>Increase the use of public transport</p> <p>Increase cycling, walking...</p> <p>Introduce intelligent traffic systems, ITS</p> <p>Introduce information systems for travellers</p> <p>Car-free zones</p> <p>Introduce traffic calming measures</p> <p>Bus and HOV priority</p> <p>Reduce use of private cars in city centres (parking fees)</p> <p>Enforcement of traffic laws and regulations</p> <p>-----</p> <p>Targets:</p> <ul style="list-style-type: none"> <li>Modal Split: Public transport share 50%</li> <li>Pedestrian/cycling share 10-15%</li> <li>Decrease private care share 40%</li> <li>% use of electric cars (20% by 2035 for the best scenario –this figure needs to be checked through electric/energy engineer)</li> <li>100% of cars should be regularly checked and maintained</li> </ul>
Water	<p>Water conservation (including agricultural activities)</p> <p>Water quality</p> <p>Non-conventional water resources (solar desalination...)</p> <p>Fresh water management</p> <p>Sufficient water supply</p> <p>Minimization of water consumption</p> <p>Recycling and reuse of treated waste water</p> <p>Provision of fresh drinking water and sanitation</p> <p>Rain harvesting</p> <p>Increase public awareness</p>	<p>Water conservation</p> <p>Water quality</p> <p>Non-conventional water resources (solar desalination...)</p> <p>Fresh water management</p> <p>Sufficient water supply</p> <p>Minimization of water consumption</p> <p>Recycling and reuse of treated waste water</p> <p>Provision of fresh drinking water and sanitation</p> <p>Rain harvesting</p> <p>Increase public awareness</p> <p>-----</p> <p>Targets:</p> <ul style="list-style-type: none"> <li>30% less water consumption (including water recycling) compared to business as usual</li> </ul>	<p>Water conservation (including agricultural activities)</p> <p>Water quality</p> <p>Non-conventional water resources (solar desalination...)</p> <p>Fresh water management</p> <p>Sufficient water supply</p> <p>Minimization of water consumption</p> <p>Recycling and reuse of treated waste water</p> <p>Provision of fresh drinking water and sanitation</p> <p>Rain harvesting</p> <p>Increase public awareness</p> <p>-----</p> <p>Targets:</p> <ul style="list-style-type: none"> <li>100% use of non-conventional water for irrigation and non-conventional irrigation</li> </ul>	<p>Non-conventional water resources (solar desalination...)</p> <p>Recycling and reuse of treated waste water</p> <p>Rain harvesting</p> <p>Increase public awareness</p> <p>-----</p> <p>Targets:</p> <ul style="list-style-type: none"> <li>100% of industries water audited on regular basis</li> <li>100% recycling of waste water where applicable</li> <li>Enforcement of the law regulating discharge into water streams</li> </ul>	<p>Rain harvesting</p> <p>Increase public awareness</p> <p>Providing clean water</p> <p>-----</p> <p>Targets:</p> <ul style="list-style-type: none"> <li>30% of reduction in water consumption in the Service sector</li> <li>All septic tanks should be modified to prevent ground water pollution and service available to empty the tanks</li> </ul>	<p>Rain harvesting for the road system</p> <p>Increase public awareness</p>

ANNEX 2: VISION AND SCENARIOS FOR TURNING NBC INTO AN ECOCITY

		<ul style="list-style-type: none"> <li>• 100% pure drinking water for everyone</li> <li>• 50% water treated using renewable energy sources in 10 years</li> <li>• 100% sanitation for everyone</li> <li>• Respect carrying capacities in terms of water availability</li> </ul>	techniques			
Waste	<p>In situ sorting of waste          Increase public awareness          Waste minimization          Recycling          Low cost technologies for waste water treatment          Biogas production from waste          Solid waste treatment          Pollution prevention          Waste minimization          Market for used goods (flea market, online sale...)          Well-functioning waste management services available          Biofuel from waste          Reduction of emissions (see energy)</p>	<p>In situ sorting of waste          Increase public awareness          Waste minimization          -----          Targets:  <ul style="list-style-type: none"> <li>• Near 100% of the waste (including both solid waste and waste water) is treated, recycled and/or reused</li> <li>• 100% of hazardous waste is properly treated</li> </ul> </p>	<p>Recycling          Low cost technologies for waste water treatment          Biogas production from waste          Increase public awareness          -----          Targets:  <ul style="list-style-type: none"> <li>• Near 100% of the waste (including both solid waste and waste water) is treated, recycled and/or reused</li> <li>• 100% of hazardous waste is properly treated</li> </ul> </p>	<p>Waste minimization          Solid waste treatment          Recycling          Recovery (including waste to energy)          Pollution prevention          Increase public awareness          -----          Targets:  <ul style="list-style-type: none"> <li>• Near 100% of the waste is treated, recycled and/or reused</li> <li>• 100% of hazardous waste is properly treated</li> </ul> </p>	<p>Increase public awareness          Market for used goods (flea market, online sale...)          Well-functioning waste management services available          -----          Targets:  <ul style="list-style-type: none"> <li>• 100% garbage collection</li> <li>• At least one functioning market place for used goods (either physical or online)</li> <li>• Near 100% of the waste is treated, recycled and/or reused</li> <li>• 100% of hazardous waste is properly treated</li> </ul> </p>	<p>Biofuel from waste          Hydrogen production          Reduction of emissions (see energy)          Recycling (tyres, other parts)          Recovery          Increase public awareness    <i>Note1: This part can't be estimated by transport planning field rather by mechanical engineer</i>          -----          Targets:  <ul style="list-style-type: none"> <li>• Enforcement of law regulating disposal of old cars</li> <li>• 100% tyres recycled</li> <li>• Near 100% of the waste is treated, recycled and/or reused</li> <li>• 100% of hazardous waste is properly treated</li> </ul> </p>
Other independent issues (material, etc.)	<p>Protect aquatic ecosystems          Conservation and sustainable use of land          Sustainable green cover          Biodiversity          Green areas          Good governance          Use of eco-friendly chemicals          Minimization of raw material use          Health and safety</p>	<p>Protect aquatic ecosystems  <ul style="list-style-type: none"> <li>• Target: Intensifying water pollution prevention to reduce health hazards and damage to ecosystems</li> </ul> <p>Conservation and sustainable use of land  <ul style="list-style-type: none"> <li>• Target: Reducing salinization, combating desertification, reducing cropland expansion, preventing soil pollution and degradation</li> </ul> <p>Sustainable green cover  <ul style="list-style-type: none"> <li>• Target: Reducing plant uprooting and removal of natural vegetation</li> </ul> <p>Biodiversity  <p>Green areas  <p>Good governance  <ul style="list-style-type: none"> <li>• Target: In general improving the legislation, but in particular, introducing the adequate legislation to allow and regulate the use of renewable energy</li> </ul> </p> </p></p></p></p></p>		<p>Use of eco-friendly chemicals            Minimization of raw material use            Health and safety  <ul style="list-style-type: none"> <li>• Target: OHS rules should be followed by all employees at all times. Develop processes to support this</li> </ul> </p>		

## ANNEX 2: VISION AND SCENARIOS FOR TURNING NBC INTO AN ECOCITY

### 2. SCENARIOS: GENERAL

#### BUSINESS AS USUAL (BAU)

- BAU is basically the description of the current situation, including the content of the Strategic Plan and the results regarding the performance indicators proposed. Population growth and economic growth should also be described. Normally, only a 10% of the plans are implemented. Political instability might be one of the reasons. Availability of own funds is another.

#### LOW INVESTMENT SUSTAINABILITY SCENARIO (LIS)

- Should contain primary energy efficiency measures (both addressing energy demand and energy production) for all sectors.
- User behaviour regarding energy efficiency.
- Introduction of renewable energy sources.
- Minimize lighting energy consumption
- Passive solutions for the residential and commercial sectors
  - Maximize the use of natural light
  - Using high mass environmentally-friendly building materials
  - Using external insulation paint
  - Using cool-color radiant paint for roofs
  - Ventilated Roof
  - Shading System
  - Natural ventilation (solar chimney)
- Energy audits for the industry sector
- Water conservation measures
- Monitoring energy and water quality inside the buildings
- Separate waste at neighborhood and district levels
- Awareness raising programme (energy, water, waste, lifestyle...)
- Sustainable urban planning and design
- Database for different sectors (data should be made available, based at E-JUST Energy Office)
- Improve public transport
- Encourage car pooling
- Improve traffic control system
- Enforcement of traffic laws
- Encourage and enabling walking and cycling
- Separate lanes for: buses/trams, cars, tuk-tuk, bicycles, pedestrians
- Develop low cost technologies for the industry
- Improving employees skills (training)
- Optimize material and energy flows in industrial processes

#### HIGH SUSTAINABILITY SCENARIO (HIS)

- Use of advanced renewable energy technologies and solutions
  - Concentrated solar power.
  - Energy storage and smart control systems.
  - District heating and cooling solutions.
  - Combined heat and power for industry.
  - Solar combined heat and power for desalination and cooling.
  - Biofuels produced from natural resources and waste.
- Upgrading the water distribution network.
- Fresh water management and rain harvesting
- Increasing production and use of non-conventional water resources (e.g. desalination)
- Hazardous waste dumping sites.
- Classification of the different industries for better common waste management.
- Solid and liquid waste management for the industry sector.
- Using non-conventional techniques for improving the added value from materials waste.
- Up to 100% recycling efficiency especially for water (Zero Liquid Discharge technology )
- Other general social and economic sustainability related initiatives (with impacts also on the main issues of concern)
  - Sanitation and health related issues.
  - NBC needs more schools and hospital.
  - Develop industrial ecoparks.
  - Smart solutions for administrative coordination.
  - Mass transport systems.
  - ITS (Intelligent Traffic System)

- Electric vehicles
- Tram and LRT system
- Street lights to increase safety for pedestrians and bikes
- Local SMEs created around sustainability (technologies, products, systems...)
- Smart monitoring and control of energy and water quality and efficiency inside the buildings and at neighbourhood level

### 3. SCENARIOS: PER SECTOR

#### RESIDENTIAL SECTOR

With regards to LIS and HIS scenarios, a particular approach has been used where possible. In particular, solutions in HIS scenario derive from the same root technology solutions of LIS scenario. Basically, basic technologies within from the LIS scenario are upgraded, adding new features. Therefore the solutions of the HIS scenario add new features to the technologies mix of the basic one.

#### BUSINESS AS USUAL

- No insulation
- Light weight envelope
- Single glazing
- Non-ventilated roofs
- Poor indoor air quality (low ventilation rate considering that smoking is allowed everywhere)

#### LOW INVESTMENT SUSTAINABILITY SCENARIO

- Maximize the use of natural light
  - Minimize lighting energy consumption
  - Using high mass environment-friendly building materials
  - Using external insulation paint
  - Using cool-color radiant paint for roofs
  - Ventilated Roof
  - Shading System
  - Separate waste at neighborhood and district levels
  - Natural ventilation (solar chimney)
- 
- Target of 30% saving in energy achieved by 2035 if this happens:
    - Change lighting system from incandescent to energy saving bulbs
    - Use automatic infra-red faucets
    - Using solar collectors to provide domestic hot water
    - Improve/introduce insulation in buildings (old and new)
    - Increase awareness to encourage people to save energy, water, food... (put special emphasis on school children)
    - Sorting of solid waste (easily done by giving each household 2 plastic bags in different colours: organic, non-organic)
    - Introduce adequate legislation and regulations, and enforcement, by the government for energy efficiency and use of renewable energy
    - To use energy efficient household equipment
    - Studies to monitor energy consumption in households
    - Building demo eco-house
  - Target of 30% reduction in water consumption by 2035 if this happens:
    - Use unconventional water tap
    - Separate grey water from black water
    - Reuse of grey water for irrigation of gardens
    - Use of grey water for flushing saving potable water
    - Educate the pupils at schools and awareness on water saving
  - Target of 40% of waste minimization by 2035 if this happens:
    - Segregation of solid waste
    - Minimization of the use of non-biodegradable plastics
    - Recycling of paper, cartoons, glass and bottles
    - Biogas production from organic fraction of municipal solid waste
    - Efficiency collection units for separate waste

## ANNEX 2: VISION AND SCENARIOS FOR TURNING NBC INTO AN ECOCITY

- Sweep streets regularly
- Separate the hazardous waste
- Improvement of the existing wastewater treatment of the city
- Separation of industrial wastewater streams
- Replication of cost-effective treatment units for similar industrial facilities
- Reuse and recycling the treated water either in irrigation or in industry

### HIGH SUSTAINABILITY SCENARIO

- PV integrated into shading system
  - Adding insulation within the building envelope
  - Performant Window (Low-e, double glass)
  - Thermal solar system for DHW and Space Heating
  - Use PV-heat pump for supplying cooling
  - Mixed ventilation (including free cooling)
  - Adopting ventilated green roof
  - Micro windmills
  - New performant envelope material (PCM)
  - Separate waste at household and building level
- Target of 60% saving in energy achieved by 2035 if this happens:
    - To develop the building code for energy efficiency for Borg El Arab and for Egypt
    - Build solar and wind energy plants to provide energy for buildings
    - Use renewable energy co-generation units to provide heat and power for a building, groups of buildings or compounds
    - Use central solar cooling plants to provide cooling for major buildings, compounds, even district cooling
    - Solar combined generation for desalination and cooling
  - Target of 100% pure drinking water for everyone by 2035 if this happens:
    - Use of low cost and efficient water treatment technologies
    - Solar energy for disinfection
    - Improvement and integration of the existing water treatment units
    - Pollution prevention
    - Courses and capacity building for pupils and workers
  - Target of 100% of waste recovery/treatment by 2035 if this happens:
    - Non-conventional and low cost wastewater treatment plants
    - Energy production from waste
    - Use waste as wealth for recovery
    - Use of green technologies
    - Zero liquid discharge units
    - Strictly follow the rules and regulations
    - Penalties for discharge of industrial wastewater
    - Create a guidelines and new obligatory for discharge of solid waste
    - Selling the energy produced from wastes
    - Reuse of treated water as a non-conventional resource

### COMMERCIAL/PUBLIC FACILITIES SECTOR

#### BUSINESS AS USUAL

- BAU is basically the description of the current situation, including the content of the Strategic Plan and the results regarding the performance indicators proposed.

#### LOW INVESTMENT SUSTAINABILITY SCENARIO

- Public awareness
- Target 100% buildings monitored and audited
- Smart use of energy
- Building demo eco-office buildings
- Using solar water heating
- Water quality monitoring inside the buildings done on regular basis
- Water conservation measures

- Recycling and reuse of waste water for irrigation and other purposes
- Develop low cost technologies for waste water treatment

### HIGH SUSTAINABILITY SCENARIO

- Use efficient lighting solutions (LED lamps)
- Waste to energy generation
- Solar air conditioning and heating
- 30% energy produced from renewable sources
- Increasing production and use of non-conventional water resources (e.g. desalination)
- Provision of sufficient fresh drinking water and sanitation
- Fresh water management and rain harvesting
- Biogas production and supply

### INDUSTRY SECTOR

#### BUSINESS AS USUAL

In order to describe the current situation in an appropriate way, the following information should be available, but as explained in the Introduction, it hasn't been possible for the expert team to access this information:

- How many plants are there in the city? What is the expected growth of that number?
- How many employees are there? What is the expected growth of that number?
- How developed is the technology used?
- How skilled are the employees? What are the required skills?
- What kinds of energy sources are used? What is the distribution of these?
- Water supply and water treatment

#### LOW INVESTMENT SUSTAINABILITY SCENARIO

- Target 100% factories monitored and audited
- Renewable energy applications
- Develop low cost technologies.
- Enhance recycling process (water -solid)
- Improving employees skills (training)

### HIGH SUSTAINABILITY SCENARIO

- Up to 100% recycling efficiency especially for water (Zero Liquid Discharge technology )
- Up to 50-80% energy produced from renewable sources
- Use more developed technology
- Using non-conventional techniques for improving the added value from materials waste.

### TRANSPORT SECTOR

#### BUSINESS AS USUAL

The Business As Usual scenario (Reference Scenario) is based on continuation of the existing travel behavior of the year 2013/2014 in the future, according to the following assumptions:

- Forecasted population based on the proposed master plan and increase rate of population
- Little change in the modal split to the benefit of the bus mode
- Change in the road infrastructures based on the master plan

#### LOW INVESTMENT SUSTAINABILITY SCENARIO

- Modal split public transport share 20%
- 100% cars should be checked and maintained
- Modal split private car share 25%
- Modal pedestrian and cycling share 7%

To achieve these targets the following measures have to be taken:

- Improve public transport
- Encourage car pooling
- Improve traffic control system
- Awareness raising

## ANNEX 2: VISION AND SCENARIOS FOR TURNING NBC INTO AN ECOCITY

- Guidelines for urban planning to include centralized parking, pedestrian paths, bicycle lanes, etc.
- Parking fees only in city centres
- Speed limit in residential calming areas
- Collective taxis
- Introducing tricycles and buscycles
- Efficient car washing service points with waste water handling system (we cannot measure this within the transportation planning field/expert)
- Reuse of tyres
- Enforcement of traffic laws
- Station for minibuses in the city
- Parking places for cars
- Parking places for bicycles
- Separate lanes for: buses/trams, cars, tuk-tuk, bicycles, pedestrians
- Reduce the number of tuk-tuks, improve and enforce the regulations
- Introducing RRT (Rapid Rail Transit) system
- Biofuel or natural gas powered public transport
- Modifying road network (traffic signals, roundabouts)

### HIGH SUSTAINABILITY SCENARIO

- 15% use of electric cars
  - Only electric cars will be allowed to circulate within Borg El Arab city centre
  - 100% cars should be checked and maintained
  - Modal split: decrease private car share 40%
  - Modal split: pedestrian/cycling share 10-15%
  - Modal split: public transport share 50%
- To achieve these targets the following measures have to be taken:
- ITS (Intelligent Traffic System)
  - Biofuels for cars and buses
  - Electric vehicles
  - PV charging points for electric vehicles
  - Tram and LRT system
  - Street lights to increase safety for pedestrians and bikes
  - Fuel cell cars
  - Building grade separate interchanges



Title	<b>EcoNBC feasibility study</b> Transforming New Borg El Arab into an EcoCity
Author(s)	Carmen Antuña Rozado, Åsa Hedman, Pekka Tuominen, Francesco Reda (VTT); Yehia ElMahgary, Ahmed ElShazly, Mona GamalEldin, Ali Kamel, Abdelazim Negm, Ahmed Tawfik, Heba Saeed, Ahmed AbdelMonteleb, Mohamed Ayeledeen, Waled Dawoud, Bahaa Elboshy, Ghada Elshafei (E-JUST); Mohamed Shahin (Alexandria University); Ahmed Yousry (Cairo University)
Abstract	<p>New Borg El Arab was inaugurated in 1988 and is seen as the natural extension of Alexandria, as well as one of the most important industrial areas in Egypt. Transforming New Borg El Arab City into an EcoCity was one of the main drivers for EcoNBC project (EcoCity Capacity Building in New Borg El Arab City). Carrying out a Feasibility Study to explore more in detail the viability of the idea was one of the first steps to be taken towards that transformation. In this case, it is the result of the joint effort of a team of Finnish and Egyptian experts through a series of structured workshops that took place both in Finland and Egypt, and a number of focused discussions that involved also key stakeholders.</p>
ISBN, ISSN	ISBN 978-951-38-8301-0 (URL: <a href="http://www.vttresearch.com/impact/publications">http://www.vttresearch.com/impact/publications</a> ) ISSN-L 2242-1211 ISSN 2242-122X (Online)
Date	April 2015
Language	English
Pages	82 p. + app. 6 p.
Name of the project	
Commissioned by	
Keywords	
Publisher	VTT Technical Research Centre of Finland Ltd P.O. Box 1000, FI-02044 VTT, Finland, Tel. 020 722 111

## **EcoNBC feasibility study**

### **Transforming New Borg El Arab into an EcoCity**

New Borg El Arab was inaugurated in 1988 and is seen as the natural extension of Alexandria, as well as one of the most important industrial areas in Egypt. Transforming New Borg El Arab City into an EcoCity was one of the main drivers for EcoNBC project (EcoCity Capacity Building in New Borg El Arab City). Carrying out a Feasibility Study to explore more in detail the viability of the idea was one of the first steps to be taken towards that transformation. In this case, it is the result of the joint effort of a team of Finnish and Egyptian experts through a series of structured workshops that took place both in Finland and Egypt, and a number of focused discussions that involved also key stakeholders.

An insight into the different economic sectors has been taken and a vision of how the main issues of concern selected, namely Energy, Water and Water, should be approached from each of those sectors has been defined, of course with a special emphasis on the sustainability of the Ecosystem. This has allowed the expert team responsible for this Feasibility Study to propose practical solutions in the form of scenarios. In the case of some sectors where reliable data was available for the calculations, these scenarios have been developed down to their associated impacts.

In consequence, by providing a more grounded understanding of the present situation and the opportunities for the future, this Feasibility Study can be useful for decision makers and planners, but also for investors, funding organizations and donors.

ISBN 978-951-38-8301-0 (URL: <http://www.vtresearch.com/impact/publications>)

ISSN-L 2242-1211

ISSN 2242-122X (Online)