



Electric Commercial Vehicles (ECV)

Final report

Mikko Pihlatie | Jenni Pippuri-Mäkeläinen (eds.)

Electric Commercial Vehicles (ECV)

Final report

Mikko Pihlatie & Jenni Pippuri-Mäkeläinen (eds.)

VTT Technical Research Centre of Finland Ltd



ISBN 978-951-38-8681-3

VTT Technology 348

ISSN-L 2242-1211

ISSN 2242-122X (Online)

DOI: 10.32040/2242-122X.2019.T348

Copyright © VTT 2019

JULKAISIJA – PUBLISHER

VTT

PL 1000

02044 VTT

Puh. 020 722 111

<https://www.vtt.fi>

VTT

P.O. Box 1000

FI-02044 VTT, Finland

Tel. +358 20 722 111

<https://www.vttresearch.com>

Preface

This report gives a broad overview of the work carried out during Electric Commercial Vehicles (ECV) -project. The project was active during 2012–2016 and it was partly funded by Tekes, the Finnish Funding Agency for Technology and Innovation (nowadays Business Finland). The project brought together multiple partners from both industry and academia in jointly funded research and development. Research parties included VTT Technical Research Centre of Finland Ltd., Aalto University, Lappeenranta University of Technology, Tampere University of Technology, Metropolia University of Applied Sciences, University of Vaasa and Rovaniemi University of Applied Sciences. Among other key information, a comprehensive list of partners can be found from the webpage of the project, www.ecv.fi [referred 27/03/2019].

Final seminar of ECV was organised in May 2016. The first day of this two-day event summarised the work carried out in the national ECV projects, whilst the second day was dedicated to a more international context through the 2nd Nordic Electric Bus Initiatives. The total number of seminar participants was around 200. This report is a collection of the work presented in the seminar and additional contributions from throughout the project. It addresses all the important aspects of electric commercial vehicles from technology to operability and operation requirements and environment.

We wish to thank all the partners and funders of the project for their invaluable cooperation and contribution.

Editors Mikko Pihlatie and Jenni Pippuri-Mäkeläinen

Contents

1. Introduction.....	9
1.1 The paradigm change.....	9
1.2 Growing international business for Finland.....	11
2. Electric Commercial Vehicles	13
2.1 Executive summary of activities 2012–2016.....	13
2.2 Summaries of work packages	14
2.2.1 Energy storage technologies (eStorage)	14
2.2.2 Electric bus technologies (eBus).....	21
2.2.3 Electrical and hybrid working machine (Tubridi).....	29
2.2.4 Vehicle systems, power grid and charging (eCharge)	38
2.3 The international context.....	46
2.3.1 Zero Emission Urban Bus System – EU ZeEUS.....	46
2.3.2 The European Bus System of the Future 2 – EBSF_2.....	48
2.3.3 Nordic co-operation of transport authorities.....	50
3. Battery technology and applications	59
3.1 Electrical and thermal characterisation of large lithium-ion batteries.....	59
3.1.1 Introduction.....	59
3.1.2 Characterisation of batteries	60
3.1.3 Experimental.....	62
3.1.4 Results	65
3.1.5 Discussion	67
3.1.6 Conclusions.....	67
3.1.7 Acknowledgements.....	68
3.2 Research highlights from experimental battery research	68
3.2.1 Introduction.....	68
3.2.2 Experimental.....	69
3.2.3 Results	70
3.2.4 Discussion	75
3.2.5 Conclusions.....	75
3.2.6 Acknowledgements.....	75
3.3 Aging of commercial NMC/graphite Li-ion cells at elevated temperatures	76
3.3.1 Introduction.....	76
3.3.2 Experimental.....	78
3.3.3 Results	78
3.3.4 Discussion	80
3.3.5 Conclusions.....	80
3.3.6 Acknowledgements.....	81
3.4 Ageing investigation of graphite/LiFePO ₄ lithium-ion cells cycled at low temperatures	81

3.4.1	Introduction.....	82
3.4.2	Experimental.....	83
3.4.3	Results and discussion.....	83
3.4.4	Conclusions.....	84
3.4.5	Acknowledgements.....	84
4.	Electric buses and powertrains	85
4.1	Electric city bus energy flow model.....	85
4.1.1	Introduction.....	85
4.1.2	Electric city bus model.....	87
4.1.3	Validation results	92
4.1.4	Discussion.....	94
4.1.5	Conclusion.....	95
4.1.6	Acknowledgements.....	95
4.2	Electric city bus demonstration environment – results from laboratory tests on commercial buses.....	95
4.2.1	Introduction.....	96
4.2.2	eBus fleet	97
4.2.3	Testing method.....	98
4.2.4	Driving resistance model.....	99
4.2.5	Results	101
4.2.6	Discussion.....	103
4.2.7	Conclusions.....	104
4.2.8	Acknowledgements.....	104
4.3	Evaluation of energy consumption and carbon dioxide emissions of electric city buses	104
4.3.1	Introduction.....	105
4.3.2	Electricity production and pathways.....	107
4.3.3	Simulation models and parameters.....	110
4.3.4	Simulation results and analysis.....	114
4.3.5	Conclusions.....	119
4.3.6	Acknowledgements.....	120
5.	Electric commercial vehicle systems and charging	121
5.1	Fundamentals of eBus fast charging.....	121
5.1.1	Defining the electric drivetrain.....	121
5.1.2	Comparing different battery and charging topologies	122
5.1.3	Results – powering at the end-stop.....	124
5.1.4	End-stop charging is a winning solution	126
5.1.5	Conclusions.....	127
5.2	Feasibility of electric buses in public transport.....	128
5.2.1	Introduction.....	128
5.2.2	Experimental / methodology	129
5.2.3	Results	130
5.2.4	Discussion.....	131

5.2.5	Conclusions.....	132
5.3	Lifecycle cost evaluation of electric bus operation.....	132
5.3.1	Introduction.....	133
5.3.2	Research method.....	134
5.3.3	Lifecycle cost calculation.....	135
5.3.4	Vehicle and operating data.....	136
5.3.5	Results.....	139
5.3.6	Conclusions.....	143
5.3.7	Acknowledgements.....	144
5.4	Guiding system for energy efficient electric bus operation.....	144
5.4.1	Introduction.....	145
5.4.2	Future needs for communication and data sharing with electric buses.....	146
5.4.3	Driver assistance.....	147
5.4.4	Auxiliary device energy consumption.....	150
5.4.5	Conclusions.....	155
5.4.6	Acknowledgements.....	155
6.	Electric vehicles vs. power grid.....	156
6.1	Electric vehicle controlled charging.....	156
6.1.1	Introduction.....	156
6.1.2	Methodology and case examples.....	157
6.1.3	Discussion.....	162
6.1.4	Conclusions.....	163
6.2	Electric vehicle charging as a frequency containment reserve on a power system level: a simulation study.....	163
6.2.1	Introduction.....	164
6.2.2	Methodology.....	165
6.2.3	Results.....	166
6.2.4	Discussion.....	169
6.2.5	Conclusions.....	170
6.2.6	Acknowledgements.....	170
6.3	Smart grid integration simulation of electric bus chargers with power quality services and local PV production.....	170
6.3.1	Introduction.....	171
6.3.2	Methodology.....	171
6.3.3	Results.....	177
6.3.4	Discussion.....	181
6.3.5	Conclusions.....	182
6.4	Electric vehicles in electricity grids.....	183
6.4.1	Introduction.....	183
6.4.2	Threats and opportunities of EV's in regard to the electricity system.....	184
6.4.3	Towards an efficient holistic system.....	187
6.4.4	Conclusions.....	188

6.5	Modelling of grid-friendly charger topologies for electric vehicles	189
6.5.1	Introduction.....	189
6.5.2	Modelling.....	192
6.5.3	Simulation results.....	195
6.5.4	Discussion.....	198
6.5.5	Conclusions.....	198
6.5.6	Acknowledgements.....	198
7.	Electric and hybrid working machinery.....	199
7.1	Future trends of hybrid and electric powertrains in non-road mobile machinery	199
7.1.1	Introduction.....	199
7.1.2	Predictions for the electrification of mobile machinery.....	200
7.1.3	State-of-the-art.....	203
7.1.4	Technology drivers and trends.....	205
7.1.5	Technology enablers.....	208
7.1.6	Considerations and recommendations	211
7.1.7	Acknowledgements.....	212
7.2	Fully electric machinery for ports	212
7.2.1	Introduction.....	213
7.2.2	Concept and technology.....	215
7.2.3	Solutions	217
7.2.4	Conclusions.....	221
7.3	Electrification of harbour machinery – TCO of battery-electric machinery	221
7.3.1	Introduction.....	222
7.3.2	Methodology.....	222
7.3.3	Results	223
7.3.4	Discussion.....	224
7.3.5	Conclusions.....	225
7.3.6	Acknowledgements.....	225
7.4	Virtual platform for NRMM hybridisation research	225
7.4.1	Introduction.....	226
7.4.2	Methods	227
7.4.3	Results	229
7.4.4	Discussion.....	235
7.5	Full-scale series hybrid mining loader with zonal hydraulics.....	236
7.5.1	Introduction.....	236
7.5.2	Test setup.....	237
7.5.3	Main powertrain	238
7.5.4	Electromechanical steering.....	243
7.5.5	Working hydraulics.....	245
7.5.6	Discussion	247
7.5.7	Conclusion.....	250
7.5.8	Acknowledgements.....	250

Appendix A: Publications.....	A-1
--------------------------------------	------------

Appendix B: Theses	B-1
---------------------------------	------------

Abstract

The Electric Commercial Vehicles (ECV) was a project entity under the EVE programme of Tekes, the Finnish Funding Agency for Technology and Innovation. ECV created an extensive and diverse research and expert infrastructure and network for electric commercial vehicles in Finland. In this context, 'Commercial vehicle' is to be understood in the broad sense, including commercial vehicles such as city buses and trucks, utility vehicles, cargo transport and non-road mobile machinery as well as light and heavy passenger cars. ECV gathered together a large number of companies in the industry, research institutes and universities. The network and results of ECV were and continue to be directly exploited by approximately 30 domestic or international technology companies operating in the electric commercial vehicle value chain. The project also involved several public domain stakeholders.

The core themes of ECV were testing and research (both in the field and in the laboratory, on different levels, from components to entire systems) as well as modelling and simulation. The cumulative competence chain in modelling serves the end user: Components - subsystems - vehicles - field applications for vehicles. Testing activities accumulate knowledge and integrate it in the transition from component to machine.

This report gives an extensive overview of the results of ECV in form of articles written by several project participants. All the key themes of the project are covered: battery technologies and their applications, electric powertrains and electric vehicles, city buses, non-road mobile machinery, electric commercial vehicle systems and charging, as well as electric vehicles in connection with power grid. In addition, the project is placed in the international context via a couple of examples.

1. Introduction

1.1 The paradigm change

Authors: Nils-Olof Nylund

Affiliations: VTT Technical Research Centre of Finland Ltd

Emissions from transport have to be reduced significantly. This goes for local pollutants, in particular oxides of nitrogen and particulate matter, as well as for greenhouse gas emissions. Zero tailpipe emission electric vehicles alleviate problems with local pollution and can bring down greenhouse gas emissions as well, on the condition that low-carbon or carbon neutral electricity is available.

In June 2016, the European Commission presented its strategy for low emission mobility¹. The three main elements of the strategy are:

- Increasing the efficiency of the transport system by making the most of digital technologies
- Speeding up the deployment of low-emission alternative energy for transport, such as advanced biofuels, electricity, hydrogen and renewable synthetic fuels and removing obstacles to the electrification of transport
- Moving towards zero-emission vehicles. While further improvements to the internal combustion engine will be needed, Europe needs to accelerate the transition towards low- and zero-emission vehicles (plug-in hybrids, full electric cars and fuel cell vehicles).

The 2016 climate strategy of the Finnish Government calls for a 50% reduction in transport greenhouse gas (GHG) emissions by 2030 (reference year 2005)². By 2050, to achieve sustainable transportation, GHG emissions from transport have to be reduced by some 60...80%. Electrification will be one important element in achieving the targets, regarding both air quality and GHG emissions.

When speaking of electric vehicles, focus is often on passenger cars as by far the largest number of vehicles are in this segment. In recent years, there has been a significant increase in the offering of electric passenger cars and this development

¹ https://ec.europa.eu/transport/themes/strategies/news/2016-07-20-decarbonisation_en

² <http://tem.fi/en/energy-and-climate-strategy-2016>

will continue, although electric vehicles are still more expensive to buy than conventional cars. Commercial vehicles, e.g. city buses and certain types of mobile machinery, with a high degree of utilisation, offer very attractive opportunities for electrification of especially urban fleets. In best use cases and careful systemic implementations, these fully electric fleets are cost effective already today.

In 2013–2016, VTT Technical Research Centre of Finland Ltd ran the research programme “TransSmart” on smart low-carbon mobility³. TransSmart designed to serve as a platform for strategic research for transport in order to create a fluent, cost-effective and environment-friendly transport system. The building blocks in creating a better transport system include elements such as low-carbon energy, clean and energy-efficient vehicles (including electric vehicles), high-performance ICT solutions, adoption of intelligent transport services as well as pro-active socio-technical transition. The themes of TransSmart are presented in **Figure 1**.

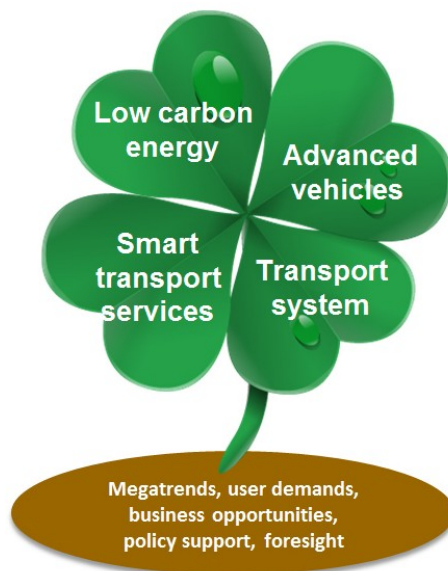

Figure 1. Themes of the TransSmart programme.

In the early 2010s, VTT’s focus within transport electrification and e-mobility was in electric commercial vehicles and their systems. The Electric Commercial Vehicles (ECV) project, with multiple partners from both industry and academia and with funding from Tekes, the Finnish Funding Agency for Technology and Innovation, was one of the most comprehensive and important elements of TransSmart.

VTT and TransSmart signed a framework agreement with Helsinki Region Transport (HSL). HSL is responsible for public transport and the transportation system in metropolitan Helsinki, and is actually procuring more than 60% of the bus

³ http://www.transsmart.fi/transsmart/in_english

services in Finland. The cooperation covered fuel efficiency, sustainable biofuels, electrification of the bus system, smart mobility services, continuous improvement of the tendering system and foresight, all key topics within TransSmart.

One highlight of the good cooperation within ECV and with HSL was the establishment of the Finnish electric bus manufacturer Linkker, and the set-up of the pre-commercial “ePELI” electric bus pilot programme in Metropolitan Helsinki. As a result of the “ePELI” project, 10 battery electric buses were set in operation, with supporting fast charging infrastructure in the cities of Espoo and Helsinki. In addition, the “ePELI” project has established cooperation with other cities both on the national and international level.

1.2 Growing international business for Finland

Authors: Matti Säynätjoki¹, Martti Korhikoski¹, Markku Antikainen¹ (Tekes EVE coordinator) and Mikko Koskue²

Affiliations: ¹Tekes⁴, ²Finpro

A significant motivation to launch a specific programme in the field of electric vehicles in 2011 was the increasing demands to decrease local and global CO₂ and other exhaust gas emissions caused by road traffic. At the same time, also the need to improve the efficiency and productivity of vehicles increased. Electrification of the vehicle powertrains is one promising way to improve the overall vehicle energy efficiency.

The main mission of the Tekes EVE programme was to find ways to create new businesses based on possibilities and technologies for Finnish companies in this renewing business environment. The main target for the programme was to create electric mobility ecosystems that could generate new knowledge and competence in EV-related technologies and services. From the very beginning, all the development was focused on international business opportunities. In 2010, the electric mobility turnover of the Finnish companies was 200 million EUR, practically all coming from heavy-duty machinery. When the Tekes EVE programme started, the target was set to two billion euros for 2020.

Finland has a strong industry manufacturing mobile machines and special vehicles for industrial and commercial applications. Many of the companies have significant market shares in their typically relatively narrow business areas. Their products and services are usually important parts of the owner’s production process. Thus, economical and technical performance together with operational reliability and safety are the most important factors in decision making when new machines or vehicles are selected.

The limited knowledge and experience from actual performance of the vehicles and their critical components was found to be the most important limiting factor for growth of the electric commercial vehicle utilisation. The situation has been similar both in the area of heavy-duty machinery and in the area of electric buses. Also, the

⁴ Tekes – the Finnish Funding Agency for Technology and Innovation, www.tekes.fi

number of the suppliers capable of providing ready integrated electric powertrain solutions to heavy-duty vehicle manufacturers is limited. These together make the development of test environments and capabilities that were made in Electric Commercial Vehicles (ECV) vitally important for future business possibilities: some basic knowledge and all application understanding must be created through own activities.

In the ECV project entity, Finnish companies and research organisations together have created a wealth of deep knowledge on which future businesses can be built. The co-operation network between different actors plays a big role in this. Other important parts are enhanced test and simulation environments and experiences from demanding environmental conditions.

As concrete results from the activities carried out in the ECV projects, several machine manufacturers are developing and already in some cases have launched products and solutions based partly or completely on electrical powertrains. Besides that, also Finnish component and system manufacturers have developed new products and opened new international markets for their solutions. A new electric bus manufacturer, commercialising the result of the projects, was founded already during the programme and it has begun its operations successfully.

The effect of electrification on the business of machine or vehicle manufacturing is naturally difficult to separate from the development of the business over all. But energy efficiency, minimal local exhaust gas emissions and the overall economy will be important competitive factors in the future and electrification can provide reasonable solutions for these needs. As a strong industry having a long tradition, high technological skills and deep understanding of customer needs, the Finnish heavy-duty machinery industry has good possibilities to be successful in the future markets of electric and hybrid machines. Also smaller machine, component and service suppliers have the potential and possibilities to grow together with market and technology change. We have a good reason to believe that heavy-duty vehicle and component manufacturers will cover a major share of the two billion euro target set for the EVE programme.

Finnish bus operators and mobile machine manufacturers that have actively participated in ECV-projects have developed their image and reputation as pioneers of new green solutions besides developing new capabilities and technologies. For instance, operational tests carried out in real Nordic winter conditions with several different electrical buses from different manufacturers have received a lot of positive international publicity. This kind of image probably has had larger impacts on the Finnish economy than the machinery industry has with its business ecosystems alone.

As a conclusion, ECV as a whole has acted as a creator of new knowledge and experimental facilities needed for new business development. Besides the moving machinery industries, these facilities have excellent potential to support the development of other business sectors, such as the maritime industry or distributed energy production system providers. Now it is the right time to capitalise on the created facilities in commercial development activities.

2. Electric Commercial Vehicles

2.1 Executive summary of activities 2012–2016

Transport, mobility and production systems are undergoing a transformation towards electrification. Electric Commercial Vehicles (ECV) was a networked R&D project entity under the Tekes EVE programme during 2012–2016 that was nationally set up to support this transformation in Finland. ECV consists of a public research project and a number of commercial research and development projects run by companies. In addition, public transport authorities (PTAs) and cities are active in their own development projects regarding electrification of public transport. The network comprised more than ten industrial projects and participation of more than 30 companies through joint funding of the public research project. The total integrated volume of the projects within the ECV entity during 2012–2016 was in excess of 20 million EUR.

ECV created an extensive and diverse testing and expert infrastructure and network for electric commercial vehicle-related industries. In this context, the term ‘Commercial vehicle’ is to be understood in a broad sense, including commercial vehicles such as buses and trucks, utility vehicles, cargo transport and non-road mobile machinery as well as light and heavy passenger cars and vans. What is more, the projects address most of the relevant value chain, ranging from components, subsystems and complete vehicles to the integration of the ECVs into the transport system and the power grid. The need for such an inclusive approach arises from requirements for more efficient, productive and sustainable solutions in public transport, logistics and industrial production.

ECV gathered together a large number of companies in the industry, research institutes and universities. The network and results of ECV were directly exploited by approximately 30 domestic or international technology companies that are positioned differently in the electric commercial vehicle value chain. Collaborators and beneficiaries of the activities involve several public domain stakeholders, too. VTT was the coordinator of the ECV network. The research partners have included Aalto University, Lappeenranta University of Technology, Tampere University of Technology, University of Vaasa, as well as Metropolia University of Applied Sciences and Rovaniemi University of Applied Sciences, which both took part during 2012–2013.

The focus of ECV is on the electrification of commercial vehicles such as buses, and mobile machinery, aiming at new development topics, products and system pilots. The topic is addressed combining applied research, open development platforms such as VTT’s own prototype electric bus and living lab type system pilots. The technological highlights of the ECV projects include the following outcomes in terms of new industrial activity, products, facilities and pilot activities:

- Electrification of public transport, electric bus pilots on-going in HSL/Helsinki capital region, Turku and Tampere
- Linkker Ltd electric bus manufacturer established as spin-off from VTT
 - Current orders ~20 fully electric buses
- Kalmar released hybrid and fully electric straddle carriers, FastCharge™
- Visedo electric and hybrid powertrains implemented in several vehicles and working machines
- New R&D facilities and capabilities available at VTT and universities

In the public research domain, the topics of research organised as work packages of the project were: 1) battery technologies, 2) electric buses, 3) hybrid working machines, and 4) systems including charging technologies for heavy-duty applications, power grid aspects, ECV system design as well as techno-economics of electric commercial vehicle systems. Activities in each of these work packages are summarised in the following section 2.2.

Dissemination and networking has been a central part of ECV. A number of meetings, workshops and seminars have been arranged during the project period. These have included the following types of activities and events:

- Steering committee meetings in each of the work packages
- Dissemination seminars arranged within the work packages
- Kick-off of the ECV network, Espoo, on the 5th of September 2012
- Autumn seminar on the 17th of September 2013, Espoo, organised together with FIMA and Finnish Technology Industries
- The 1st national ECV seminar and kick-off of the 2nd period of ECV, Espoo, on the 24th of September 2014
- The 2nd national ECV seminar, Tampere, on the 10th of March 2015
- The 3rd national ECV seminar, Lappeenranta, 3rd of October 2015
- The final seminar of ECV combined with the 2nd Nordic Electric Bus Initiatives conference, Espoo on the 11th–12th of May 2016.

2.2 Summaries of work packages

2.2.1 Energy storage technologies (eStorage)

Authors: Ville Erkkilä¹, Ari Hentunen², Panu Sainio³

Affiliations: ¹VTT Technical Research Centre of Finland Ltd, ²Aalto University, later VTT, ³Aalto University

The eStorage project was established to increase Finnish know-how in the field of energy storage technologies, especially rechargeable batteries. This was achieved by building state-of-the-art testing facilities, databases, modelling and simulation tools, and bringing together a wide network of Finnish industry. In the battery laboratory, it is possible to characterise and evaluate batteries from single cells up to complete battery packs, including temperature tests in a controlled environment. Developed testing methods enable quick characterisation of battery performance,

which can then be easily brought to MATLAB Simulink for further analysis through modelling and simulation. Battery testing has shown that there is considerable variation between different manufacturers. Therefore, battery selection for each application must be done by knowledge and reliable facts.

2.2.1.1 Introduction

Energy storage is and will be the most central and challenging part of electric and hybrid vehicles. The main challenges regarding energy storages are the cost, lifetime, safety, performance, and thermal management. Together with the challenges, the fast development of the technology makes it difficult to utilise energy storages. However, political measures, environmental issues, and reducing dependency on oil encourage the utilisation of energy storages. Before the ECV programme, know-how on modern and especially Li-ion energy storages was scattered and insufficient. The aim of energy storage research was to support the development of the whole electric commercial vehicle industry by building a bridge from the battery material and chemistry research to the development of industrial applications.

2.2.1.2 Experimental / methodology

To find solutions for the challenges related to energy storages, eStorage utilised extensive experimental research work together with modelling, literature reviews and the network created by the ECV programme. At the beginning, both VTT and Aalto built experimental readiness and significant expertise related to advanced energy storages. This has benefitted especially the project partners but also the whole ECV network. The approach of eStorage2 was based on three levels: battery cell, battery module, and battery pack, where VTT and Aalto cooperated to widen know-how and testing capabilities. The first two years of the project showed how long the process is to create a new research area and the related know-how. Aalto had a flying start based on previous projects and cell-level aging testing started right from the beginning with one type of cells. But already the planning, purchasing and building of new research facilities closer to industrial scale needs to be capable of having variety of solutions and recruitment and further education of personnel took over a year. Towards the end of the eStorage2, also more results were obtained. However, it was clear that a continuation of the work was needed to attain results that have real benefit for the industry. Thus, eStorage3 was proposed and later funded for the second period of ECV. In eStorage3, the main field of operation was to produce knowledge, tools, and solutions for energy storage development and utilisation.

2.2.1.3 Results

At VTT, the experimental work has produced a battery database, which contains the characteristics of close to 150 battery cells from 11 different manufacturers. This database can be used for choosing the best battery type for each application. Also,

four different battery types have been tested in an environmental chamber in temperatures ranging from +40 °C to -30 °C. In addition, calendar life testing was performed with four different battery types. Furthermore, lifetime testing is still ongoing and so far 18 battery cells have been under testing from three different manufacturers.

The wide range of cells tested has shown that quality variations exist between different manufacturers. The quality is best seen as the uniformity of the cell characteristics. The more uniform the cells are, the better the performance is on the pack level. With battery cells, higher price usually provides better quality.

Environmental testing has shown that temperature has a strong impact on cell performance. When the temperature is increased, the cell performs better. When the temperature is lowered, cell performance is decreased considerably. However, aging occurs faster at higher temperatures and slower at low temperatures. Therefore, a balance needs to be found between performance and lifetime. **Figure 2** illustrates the charge performance of different cells in different temperatures. The horizontal axis shows the temperature and vertical axis shows the 1C constant current charge capacity in per cents from the nominal.

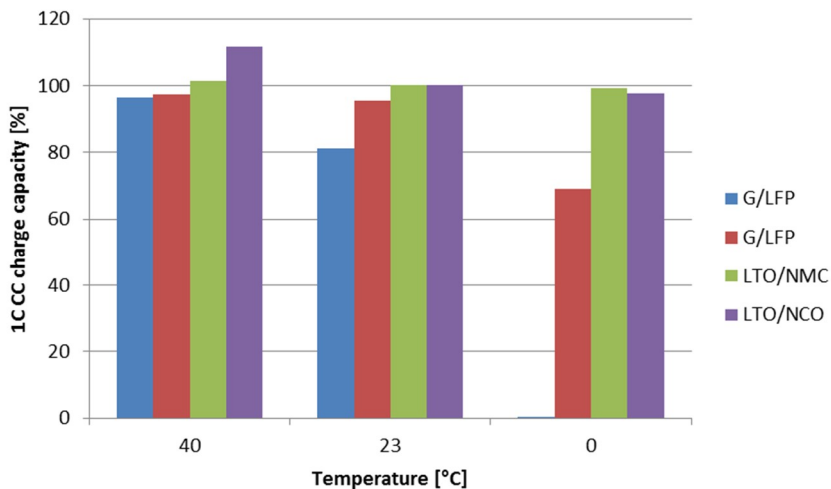

Figure 2. Cell performance characteristics in different temperatures at 1C charge.

In the figure above, the charge performance difference between lithium titanate (LTO) and graphite anodes is clearly seen. LTO cells charge well regardless of the temperature, while cells with graphite anodes show a significant drop in charge performance in lower temperatures. Furthermore, in graphite anodes, charging in lower temperatures poses a safety risk due to the plating of metallic lithium on the graphite surface, which can lead to an internal short circuit in the cell.

Lifetime test results have shown that the battery chemistry impacts the cycle lifetime of the battery the most. Under similar test conditions, a cell with an LTO anode and a cathode with oxides of Ni, Mn and Co (NMC) was tested over 1500 cycles and only increase in the capacity of the LTO/NMC cell was seen. Under similar testing, a cell with graphite (C) anode and a lithium iron phosphate (LFP) cathode (C/LFP) chemistry degraded to 80% of original capacity with 2000 cycles. Also, the average state of charge (SoC) has a significant impact on aging. The cell with the highest average SoC degrades the fastest while the cell with the lowest average SoC degrades the slowest. **Figure 3** shows the cycle lifetime results for the C/LFP cell. The test in **Figure 3** consists of 1C charge with 2C discharge with a 10-minute rest in between. The impact of the average SoC on the cycle life is clearly seen in this test.

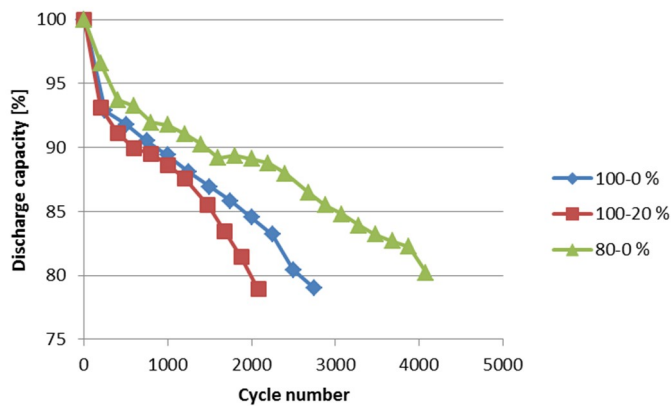

Figure 3. Cycle lifetime of C/LFP cells at different SoC windows.

During the project, also diagnostic methods for battery state of health (SoH) estimation were developed. Incremental capacity analysis and differential voltage analysis methods were studied and their applicability was under research. These methods can be used to identify the degradation mechanisms of a battery. Also, a completely novel method of $1/f$ noise measurement was studied, but further research is needed to make conclusions about the method.

At Aalto University, the research focused on the electrical and thermal characterisation of battery modules and packs. There an accurate and computationally lightweight battery model for large battery packs was developed. The methodology also contributed to reduction in the time and effort involved in the experimental testing and parameterisation. Special attention was paid to the characterisation of the internal impedance and entropy change, which both have a great impact on the accuracy of the model.

As a result, a semi-empirical modelling approach, in which the battery model consists of coupled lumped-parameter electrical and thermal models and the characterisation is performed on the basis of current, voltage, and temperature data, was adopted. Moreover, a systematic methodology was developed for the effective characterisation of the capacity, open-circuit voltage, internal impedance, entropy change, and thermal properties of commercial battery modules by using only two experiment types: (i) galvanostatic intermittent discharging and charging and (ii) continuous thermal loading. Module-level characterisation inherently includes the manufacturing tolerances between the cells in a module as well as the effects of the cooling system into the model. Furthermore, it results in a low-order model that can be scaled for any battery pack configuration.

The use of a conventional potentiometric method for entropy change characterisation takes several weeks to complete. In this research, a novel entropy change characterisation method was developed, which uses the empirical temperature data from the galvanostatic intermittent discharging and charging experiments and the corresponding estimated temperature data to extract the entropy change characteristics. The advantage of the method is that no dedicated characterisation experiment is needed.

As an example, the results of a validation test are shown in **Figure 4**. The voltage and temperature predictions are very accurate throughout the test. The shape of the heat generation during the cycle differs remarkably, because the entropy change characteristics for discharging are endothermic at 46% SoC and exothermic at 22%, and vice versa for charging. Accurate temperature prediction cannot be achieved without taking the entropy change into account.

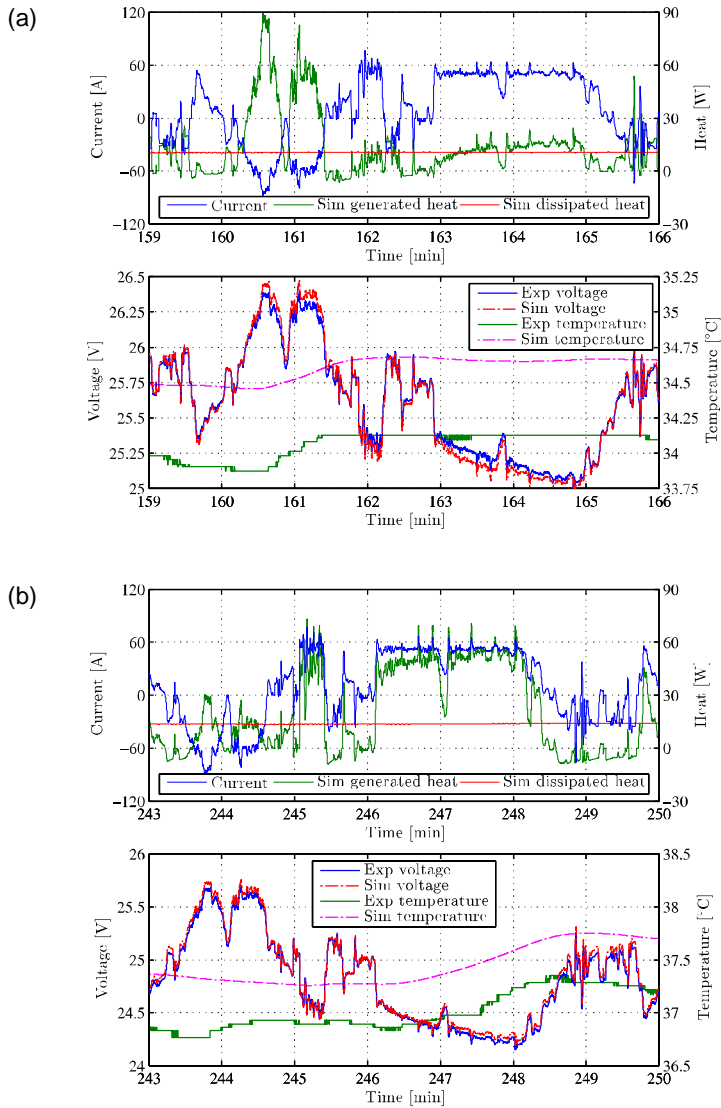

Figure 4. Results of a validation test at 25 °C ambient temperature, enlarged at around 46% SoC in (a) and 22% SoC in (b). A commercial battery module with C/NMC chemistry was used. The duty cycle represents a real-world duty cycle of an underground mining load-haul-dump loader.

The proposed modelling methods, characterisation experiments, and parameter extraction algorithms offer a systematic and flexible methodology to perform effective battery characterisation and result in robust and accurate prediction of the SoC,

voltage, heat generation, heat dissipation, and temperature. The model can be used in the system-level simulations, as well as in the electrical and thermal performance assessment of battery cells, modules, and packs. Moreover, the model can be compiled into a real-time model, which can be used in conjunction with a battery cyler to emulate a battery in a hardware-in-the-loop powertrain testbed.

2.2.1.4 Discussion

In a short time, we have been able to gather a lot of data for our battery database and this can be used as a design and dimensioning tool for industrial battery development. As battery technology is developing constantly, we need to continue testing to keep up with the developments and update our database. A lot more cycle life testing has to be done to be able to answer questions related to lifetime estimation of batteries. Also, the scientific literature lacks real tests studying the influence of depth of discharge (DoD) on cycle life. Therefore, this work would be important to gain more insight into the optimal operation of batteries. Further work needs to be done also on the diagnostic methods of battery state of health estimation.

The commercial potential in the field of energy storages is immense as the environmental and political factors are driving development towards greener solutions. Already now there are numerous projects in electrification of all kinds of vehicles – land, sea, and air. Also, stationary energy storages are becoming more important as we try to incorporate more renewable energy sources into the grid in a stable way.

2.2.1.5 Conclusions

The eStorage projects have been successful in establishing the field of applied battery research in Finland. Both VTT and Aalto University have gathered important know-how on energy storage technologies in general and in particular knowledge, tools, and solutions for energy storage development and utilisation. Extensive experimental testing facilities have been built and the personnel to use them have been educated.

The experimental research has so far shown the performance differences between different commercially available batteries. The cathode and anode materials used have significant impacts on cell performance. Thus, the selection of the most suitable battery for each application must be considered carefully. Furthermore, our tests have shown that the selection of the most suitable chemistry is not enough as there are considerable variations in cell manufacturing quality. To ensure that the quality of the cells considered for an application is also on the required level, experimental tests with a large enough number of cells are recommended. When the battery manufacturer and the cell type have been chosen, careful design is also needed to make sure that the battery is operated optimally to achieve maximum lifetime for the battery. The tools developed in this project will be of help in all stages of product development.

2.2.2 Electric bus technologies (eBus)

Authors: Teemu Halmeaho¹ and Antti Lajunen²

Affiliations: ¹VTT Technical Research Centre of Finland Ltd, ²Aalto University

To evaluate the prospects for electrifying urban public transportation, an eBus project was set up by bringing together the key actors in public-private partnerships: state and public transport authorities, municipalities, bus operators, utilities, technology companies and research institutes. The project established a world-class electric bus test platform and generated experiences from electric bus technologies and their real-life performances. The buses were tested in the field by actually running a bus route in Espoo (route 11) in harsh climatic conditions. In addition, laboratory testing for determining, e.g., efficiencies and driving cycle dependence, were carried out. A special full-size electric bus was built to serve as a platform for component testing and setting references. Computational tools to support the bus design and operation planning for battery electric buses were developed. The paper describes these studied topics during the five-year project.

2.2.2.1 Introduction

A major question, which arose at the beginning of the project, concerned the feasibility of electric buses. It can be seen that a positive answer has already been found for this question, and it has already been redefined to be: When electric city buses are introduced, what form will their implementation take? The project arose from the clear need to ascertain whether electric buses could compete with conventional technologies. Although environmental benefits were in place, the prospects for economic profitability were unclear. No comparison was yet possible between different types of electric buses; an environment was required in which research on electric buses and their systemic implementation could be conducted. Since Transdev Finland Oy (formerly Veolia) already had relatively long experience with testing electric buses, the eBus project can be regarded as arising from the mutual desire of the bus operator and research centre to develop such a research environment. With the involvement of Helsinki Regional Transport (HSL) and the City of Espoo, collaboration expanded to include key parties with an interest in the matter. The undertaking also seemed to interest a large number of the relevant Finnish stakeholders and it was easy to find parties interested in co-operation, since the time was ripe for such a venture. With respect to their products, component manufacturers were well placed to become involved. While a research environment was needed in order to study commercial buses, for component development purposes a platform was required as a research environment for generating references.

The project's achievements can be divided into three parts; 1) the development of a prototype electric bus to function as a testing platform for the components of an electric city bus; 2) the creation of a research environment for commercial electric buses and 3) the creation of co-operation links between public and private sector actors whilst offering them information in support of decision-making.

The prototype electric bus, the 'Test Mule', developed under the project enables the testing and development of the components of a heavy-duty vehicle electric powertrain within an independent research environment. Such a testing platform for components for this heavy vehicle can serve as a reference for manufacturers of energy-efficient products, without being limited solely to powertrain components. However, maximisation of overall energy efficiency entails the control of all energy flows and it is with respect to this aspect that use of high-efficiency auxiliary equipment was also studied.

During the project, a database was formed based on the electric buses subjected to measurements. By using this database, the energy efficiency of the average electric city bus can be obtained based on the average value for the measured buses. This reference database will also serve as a benchmark for buses to be measured in the future and for diesel and gas buses already being measured at VTT Technical Research Centre of Finland Ltd.

2.2.2.2 Field testing

Commercial electric buses were run along the route in a real operation environment for a period of three years. Any potential deterioration in the performance of a bus along the operation was identified in annual monitoring, based on which the buses are subjected to performance measurements in laboratory conditions. Above all, there is a question mark concerning the ageing of the vehicle's battery in the actual operation environment. In Finland's winter conditions, the temperature of a battery can vary considerably and deplete the battery more rapidly than usually estimated. Conditions of this kind require thermal management of the battery. The Battery Management System (BMS) does, in fact, play a key role in ensuring optimal functioning of the battery in cold as well as hot weather conditions.

2.2.2.3 Commercial buses

In practice, no previous research information had been established on the general standard of technology in electric city buses, and development has only begun in earnest over the last few years. The objective of the eBus project was to generate such information on the current standard of commercial buses. For this reason, the search for buses suitable for the project had to be conducted by visiting the manufacturers on site. The bus operator, Transdev was the body that leased buses, while VTT provided support with selection. The manufacturers were offered access to the research results on the performance of their buses compared with the average results for other buses, in return for a reduction in the purchasing price of their buses.

The first arrival was the Portuguese Caetano, which made its entrance at the end of 2012 (**Figure 5**). This airport bus-based vehicle was still clearly a prototype. The Chinese-Dutch Ebusco (**Figure 5**), which arrived a year later, was a considerably more refined solution. During the first year, the Caetano experienced a large number of problems, particularly due to its inability to withstand low temperatures. The

vehicle was upgraded and repaired by the manufacturer several times. It was dispatched to Portugal to be refitted in summer 2013. Ultimately, the manufacturer managed to get it working fairly well in time for the following winter. No major problems were encountered with the Ebusco, although it should be borne in mind that the winter 2013–2014 was generally very mild. Both buses performed well during a weeklong period with temperatures down to $-20\text{ }^{\circ}\text{C}$. In summer 2014, owing to various problems and the need for adjustments, the Caetano was returned to Portugal but it came back after a year.

In summer 2014, the project was supplemented by two buses the Chinese BYD and the Dutch VDL (Figure 6). The BYD worked well for the whole year and half the testing period despite the noise its drivetrain was generating. The VDL had problems with its in-wheel traction motors, which were repaired two times during the project. During spring 2015, the Ebusco was replaced by the second generation Ebusco 2 (Figure 6). The original one was suffering from issues from low-quality manufacturing, while the second one had improved significantly.



Figure 5. Caetano (left) was the first commercial electric bus to arrive for testing in autumn 2012, followed by Ebusco (right) a year later.



Figure 6. BYD (top right) and VDL (bottom) joined the project in the summer of 2014. Ebusco 2 replaced the former Ebusco in spring 2015.

2.2.2.4 Laboratory measurements of electric buses

A tailored measurement technique was required in order to gather data on the electric buses. Measurements carried out using the chassis dynamometer at VTT's vehicle laboratory (**Figure 7**) enabled the database containing information on the city buses to be expanded with data collected on the electric buses. This unique database can be used to compare the performance of buses with different propulsion systems and to evaluate their energy efficiency. With respect to the electric buses, the database can also be used for reference purposes when comparing commercial electric buses to each other. The method developed for measuring overall energy consumption can be used to perform comparable cycle-specific measurements on any commercial electric bus. Thanks to such comparability, a unique testing environment for electric buses has been created in Finland. With respect to laboratory measurements, this includes determination of the distribution of energy consumption, which is of particular interest to vehicle manufacturers. VTT can thereby provide manufacturers of commercial city buses with data on their vehicles, based on measurements at the general level and more specifically on the distribution of energy consumption in the customer's bus with respect to different load cycles. For the customer, this provides e.g. a starting point for modifying the vehicle for the desired operating environment.



Figure 7. VTT's e-bus prototype and R&D platform being tested with VTT's heavy-duty vehicle dynamometer.

2.2.2.5 Testing environment for components – open R&D platform

The starting point for creating a prototype bus (**Figure 8**) lay in the need to test the components of an electric heavy vehicle in an independent testing environment.

The components to be tested were not restricted to the components of the electric powertrain, since the aim was to study energy efficiency on a broader basis than this would entail. In an electric vehicle, this means more precise control of auxiliary equipment and energy flows compared to diesel buses. In order to assess these aspects reliably, an actual prototype needed to be tested. The parties involved in planning are at the top of their field, which has enabled the reliable evaluation of various scenarios. A simulation model for the bus was used to provide support in decision-making. In addition to energy efficiency, an electric bus must be able to compete with diesel buses in terms of its reliability; this requires components that last several years in varying conditions. Experience has yet to be accrued on the durability of the components, and the impact of a cold climate in particular still needs to be assessed. Compared to commercial buses, the prototype bus could be equipped with more instruments designed to generate data on the status of the components while the vehicle was travelling along the route. In the future, prototype eBus will be increasingly used to study the optimal control of energy flows – heating and cooling of the passenger compartment play an integral part in this. Maintaining the battery at an optimum temperature and operational window is also essential from the perspective of system reliability, energy efficiency and battery life.

2.2.2.6 Simulations

Simulation tools were widely used during the eBus project for various purposes by Aalto University and VTT. In the first phase of the project, a simulation model was developed by Aalto University for the dimensioning and evaluation of the developed prototype electric bus. The simulation model enabled the evaluation of energy consumption and performance as well as investigations of the performance of individual powertrain components. The simulation model was used to conduct a number of simulations relating to the dimensioning of the Test Mule. With respect to the powertrain components, the performance requirements focused on the electric motor, the inverter and the differential gear. The requirements for the electric motor, particularly the requirement for torque, were determined by means of various simulated driving cycles. The simulation models were later on verified and validated with the data obtained from the prototype bus measurements. In the comparisons, the simulated powertrain energy losses corresponded well with results from measurements.

In the second phase, several different simulation models and tools were developed to investigate the requirements of the electric bus operation and thermal management of electric buses. At Aalto University, an analytical tool was developed for the evaluation and comparison of different solutions in electric bus operation. With the tool, it is possible to define required charging infrastructure for a given operation route or estimate the required battery capacity depending on the charging method. The tool also includes a calculation of the lifecycle cost of the electric bus operation.

A thermal management model was created at VTT to simulate the heat management in the bus cabin and powertrain cooling circuit, which is essential for controlling the bus overall energy efficiency. This enabled studying the optimal solutions for

scenarios in various operating environments. The heat losses through open doorways were studied in-depth to evaluate the prospects for air-curtain doors that reduce the mixing of cabin and ambient air.



Figure 8. VTT's e-bus prototype in commercial operation by Transdev during one week on Line 11 in Espoo.

2.2.2.7 Driving style study

The purpose of the driving style study was to ascertain how driving style affects electric bus energy consumption and to compare the driving style identified as optimal for low consumption with the diesel buses used as a point of reference. To identify the optimal driving style, the mileages involving the lowest possible consumption are sought and their speed profiles are then analysed. When the optimum driving style has been found for a particular route, a recommended speed can be communicated to the driver through a driver advisory system. The basis of the study is the driver advisory device developed for use on diesel buses by VTT. This device is a real-time driver advisory system for bus drivers. The goal and the objective of the study is to clarify an energy-saving, high-quality driving style that keeps the bus on time. The driver advisory system monitors the vehicle's movements and locations, comparing the data to the timetable and collecting data on the journey. During the project, functionality enabling the partial comparison of driving events was added to the software, allowing the analysis to focus on optimally driven stretches between bus stops or, according to need, on even shorter stretches in order to identify the optimum overall speed profiles. The result of the analysis can be generalised later for adaptation to other routes, by categorising the partial speed profiles related to each driving-stretch. In addition to guiding the driver, also bus auxiliary component guiding was studied. In this, the advisory system would control the components in location-based manner to match the realised optimal operation.

2.2.2.8 Attitudes of drivers and passengers towards electric buses

The aim was to ascertain the views and expectations of drivers and passengers regarding electric buses – and any changes in these while the electric bus is in use. This was done on the basis of driver interviews to assess drivers' experiences. The attitudes of the drivers were positive towards the tested buses and all the drivers were given an orientation to the electric buses. Expectations were towards the quietness of the buses and suspicion mostly on how the battery will manage in cold temperature. From the drivers' point of view, the electric buses did not differ much from the diesel buses. Most of the differences were not related to electrification of the buses, but more to the prototype nature of the tested individuals. In the depot, the charging was managed by the workshop personnel. In summary, the drivers considered an electric bus to be pleasant to drive because of the lower noise and vibration level, good acceleration (in some buses), and smoother ride. The drivers have received positive comments of the lower noise and smoother ride also from the passengers. A part of the smoother ride originated from the need to brake in a calmer manner to maximise the regenerated energy. As the buses had indicators of energy consumption and regeneration, it was possible to adapt to an energy-efficient driving style. The drivers reported that the limited battery energy capacity encouraged them to focus on energy consumption.

2.2.2.9 Summary

The eBus project has received a great deal of media attention from the very beginning. Within Transdev Finland's parent company, Transdev, the project was rated highly during the company's in-house innovation competition. The eBus project's high profile has prompted discussion of electric buses in general. Bodies responsible for public transport in a number of countries have shown interest in the project since, for decision-making purposes, they need precisely the same information as that provided by the eBus project.

Through the concrete steps it has taken, the project has accelerated the advent of electric buses both in Finland and abroad. Bus manufacturers around the world have been greatly interested in the eBus project. The bus manufacturers that joined the project were seeking information from Finland on how to manage in cold and snowy conditions. They wished to participate in the project in order to obtain research information on their own products, but were also interested in obtaining visibility and references. All of the parties involved have indeed gained visibility in multiple forums. An important role in the eBus project is played by the co-operation arising between the parties. New projects have been launched as a result of such co-operation. Alongside the expansion of the ECV project, the issues that emerged during the eBus project have provided a springboard for extended activities such as the eCharge and eBusSystem of the ECV network and later on the pre-commercial pilot 'ePELI' by Helsinki Region Transport HSL. At the very outset of the project, it was noted that issues relating to the charging infrastructure and charging in other

respects were so extensive and crucial that the eBus project could not address them alone.

The main objective of the eBus project was to assess the potential and feasibility of electric buses in Finland. An answer has clearly been identified to this question, with every indication that electric city buses can operate successfully in Finland. An energy efficient and environmentally friendly electric bus would also appear to be an economically competitive option. A major question at the beginning of the eBus project was whether the realisation of electric city buses was even possible. With the expansion of the ECV and the follow-up in terms ePELI and the activities of the cities of Turku and Tampere, projects now establish the foundation for larger-scale adoption of electric buses. These projects have been inspired by the questions that arose during the eBus project relating to the charging system and the infrastructure and operating practices supporting electric bus traffic.

A concrete achievement of the project is the 'Test Mule' prototype eBus, whose commercial potential is being developed in a separate spin off enterprise. In this context, the company, Linkker, is striving to manufacture an economically successful electric bus based on the Test Mule. The use of the eBus prototype as a mobile electric vehicle laboratory is continuing, enabling its use as a research tool in commercial assignments as well as for VTT's own research purposes. Use of the e-mobility research platform for components is one of the unique services offered by VTT. Another, perhaps even more unique service is the testing environment for electric buses, in which bus manufacturers can be provided with the same testing environment as that used for the commercial buses tested during the eBus project. In addition to testing, the manufacturer can view the performance of its bus in relation to general performance levels, which comprises the average performance of the buses measured by VTT. For the manufacturer, this provides evidence of the bus's energy efficiency. On the basis of distribution of energy consumption, sources of energy losses can be identified and further measures can be planned for rectifying the situation. The bus's simulation model can be used to calculate the savings potential enabled by any changes, and to compare different solutions. Data based on the measurements, simulations and calculations can be used to provide bus operators, cities and municipalities or public decision-makers in general with support in decision-making. Thanks to the eBus project, VTT's comprehensive reference database on buses with different propulsion systems has now been supplemented with data on electric buses, and thereby provides a basis for comparative evaluations. As the bus's powertrain is similar to that of many other heavy vehicles, component test results obtained can be used both in working machinery and in trucks. The simulation and measuring tools developed can be used effectively in their current condition. Know-how accumulated during the design and construction of the Test Mule is also widely applicable. Thanks to parameterised models, these simulation models can also be applied to passenger cars.

2.2.3 Electrical and hybrid working machine (Tubridi)

Authors: Panu Sainio¹, Teemu Lehmuspelto¹, Lasse Laurila², Jenni Pippuri³
Affiliations: ¹Aalto University, ²Lappeenranta University of Technology, ³VTT Technical Research Centre of Finland Ltd

2.2.3.1 Need for TUBRID

Demands for improved energy efficiency and reduced emissions are among the most important drivers for the electrification of mobile machinery. Fuel consumption will be a main focus because by improving fuel economy, the emissions and operating costs of machines can be reduced. Stringent future regulations for the air pollutant emissions of diesel engines in non-road mobile machines (NRMM) will have an influence on the system design of the internal combustion engine. The impact will be different on each machinery type and dependent on the power classification.

The strategies of the European Union (EU) and individual countries on reduction of carbon dioxide (CO₂) emissions may significantly affect the design solutions of NRMM. The emission standards are other legislative policies that have an effect on the technology choices in mobile machines. The emission limits for pollutants are likely going to be set lower in future legislation. In the new EU Stage V, particle mass and particle number emissions are regulated. The direct impact of the new emission limits is the need to use more sophisticated emission control and exhaust gas treatment systems.

In the TUBRID project, the aim is to find out what is achievable with new technologies in heavy work machines. The challenge is to build a demonstrator of a hybrid electrical mobile machine that has a higher performance than a conventionally powered machinery and that consumes only half the amount of fuel. Optimally, the demonstrator could also serve as a unique test bed in which Finnish manufacturers of powertrain components could test and demonstrate their products.

Major research questions of TUBRID can be summarised as follows:

1. How can Hardware-In-Loop (HIL) systems be utilised in engineering of new powertrains and their control?
2. Can we learn and disseminate information through yearly updating of "Technology road map for hybrid and electrical drivetrain of non-road mobile machinery"?
3. How can a higher-speed electric motor drive be adapted into a low-speed work machine with high traction force, when it was previously driven by hydraulic motors?
4. How will bucket movements be electrified?
5. How can electromechanical pivot steering be realised?
6. How can a combustion engine be downsized without losing performance – buffering with a battery?
7. Is it possible to pack a hybrid electrical powertrain and related equipment in an existing machine without making any changes to the main frame and its

dimensions, i.e. using a main frame of an existing machine with conventional powertrain directly?

2.2.3.2 Methods and workflow of TUBRIDI

In the project, Finnish research institutes, manufacturers of mobile machinery and component manufacturers join forces to build a hybrid electrical platform for mobile machines including an HIL system and a vehicle demonstrator. Building such a platform includes a lot of hands-on work and 'trial and error' problem solving. Design and engineering of powertrain configurations and demonstration and testing of different components, technology and solutions with the platform are essential elements of the project's workflow. The project combines the expertise of the research institutes involved and helps the partners to expand their cooperation.

Besides the development of the HIL system and the hybrid electrical work machine demonstrator, we worked on a 'Technology road map for hybrid and electrical drivetrain of non-road mobile machinery' in TUBRIDI. This road map was updated yearly from 2012 to 2017 and its newest versions are available at www.ecv.fi. We aimed at monitoring the development of NRMM electrification and understanding the changes in our assumptions over the project span. Results of this work are summarised in this report in a section titled 'Future trends of hybrid and electric powertrains in non-road mobile machinery'.

A course covering this subject was established at Aalto University in 2012 and it is today named as ELEC-E8112 - Hybrid powertrains in vehicles (5-credit course at M.Sc. level suitable for PhD study). Over the years, more than 120 students have passed the course.

2.2.3.3 Results of TUBRIDI

1. *How can an HIL system be utilised in engineering of new powertrains and their control?*

The Hardware-In-Loop system (**Figure 9**) of the project was in the beginning planned for energy efficiency analyses and component sizing of NRMM and other vehicles. During the project, understanding of the versatility of the system evolved. In addition to creating work cycles of different NRMM virtually and comparing fuel consumption of different powertrain versions, it was found that the system could be also utilised for many other purposes – perhaps even more important for some. A comprehensive list of the applications of the HIL system test bench is given below:

- early and later stages of development,
- energy efficiency analysis,
- productivity analysis
- work cycle creation,
- first reference tests of prototypes,
- performance analysis,

- control software development,
- bug fixing,
- testing of individual components,
- testing of systems,
- virtual prototyping,
- combining "digital twin" and hardware,
- customer validation and
- virtual validation.

The virtual simulation test bench can be operated in 'simulation only' mode or in 'HIL' mode, with a driver or recorded work cycles. The system is meant to accelerate the development of hybrid and electric NRMM.

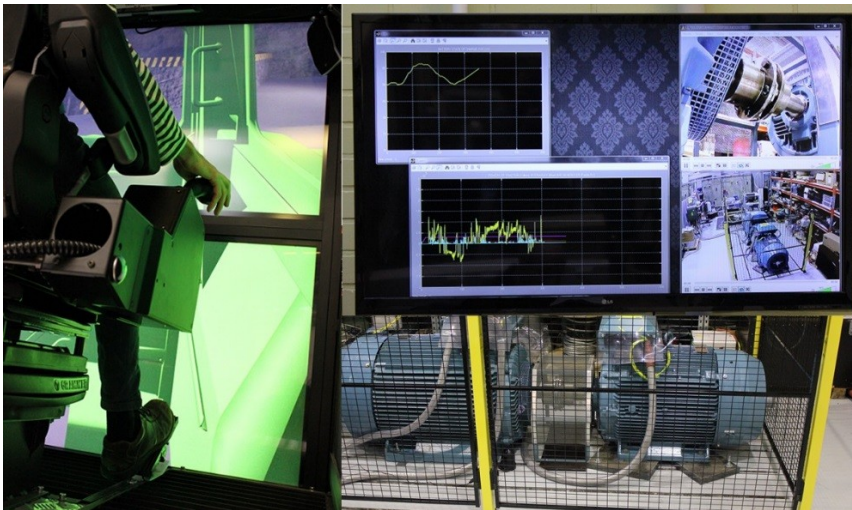

Figure 9. Hardware-In-Loop system with remote control in operation. The battery state of charge and work cycle are monitored with real electric motors and converters in the loop.

In the verification of the virtual simulation method for energy efficiency analyses, a satisfying accuracy level of 95% was achieved in a fuel consumption comparison of measurements and simulations. Fuel savings up to approximately 50% were predicted with the created hybrid models of the selected conventional and yet un-hybridised NRMM.

2. *Can we learn and disseminate information through yearly updating of 'Technology road map for hybrid and electrical drivetrain of non-road mobile machinery'?*

The road map work that was carried out during TUBRID1 proved to be extremely useful in understanding the drivers, pros and cons and developments of the NRMM

electrification. For instance, in the beginning of ECV, the fuel price appeared to be the most important driver for the electrifications, but over the years, the situation changed rather abruptly. The impact of regulations on electrification has been rather pronounced during the past year. The summary of the latest version of the road map is presented in **Figure 10**.

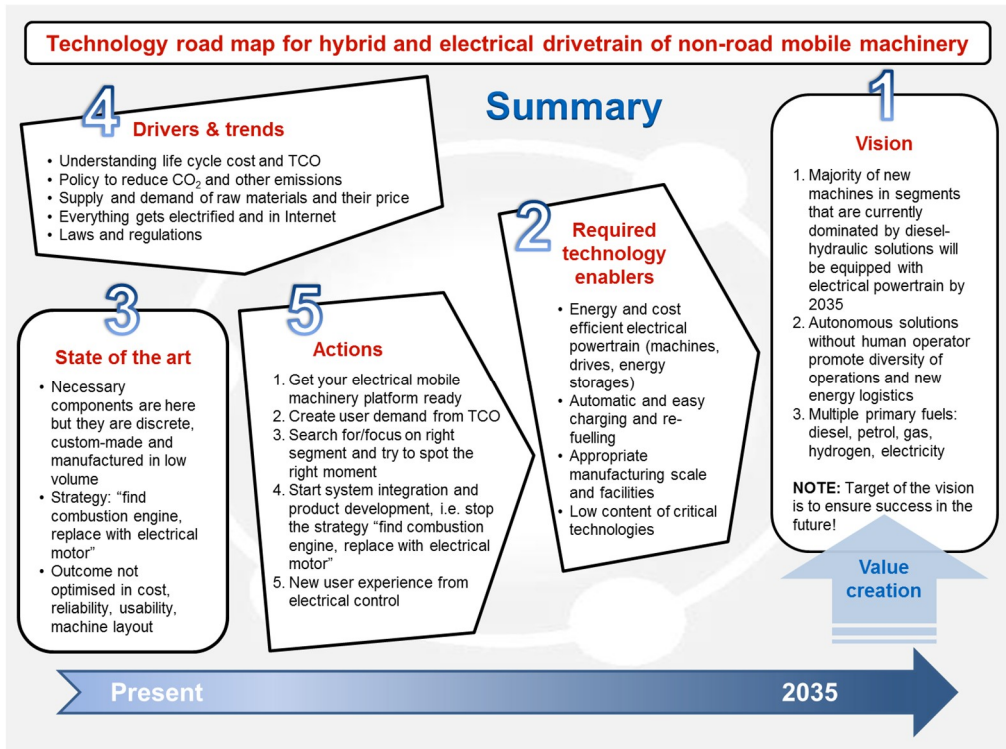

Figure 10. Technology road map for hybrid and electrical drivetrain of non-road mobile machinery.

Highlights of the latest road map version from year 2017 can be concluded as follows

- Emission regulations are becoming increasingly strict and drive the development; Stage IV in production, Stage V is a year closer.
- Price of oil was 120\$/b in the end of 2011, in 2016 it was about 27\$/b, in 2017 something like 55 \$/b. What will it be early 2018?
- Battery powered city bus turned out to be a feasible solution over the hybrids – intermediate phase of hybrids might be shorter than believed.
- Role of charging also in terms of mechanical and software connection is a critical matter still – for cars the number of charging stations is increasing rapidly.

- Tesla Gigafactory and other similar developments? How will this affect battery technology development and prices?
- New voltage levels, like 48 V in passenger cars, i.e. small steps are taken continuously now – noticing these steps demands observation.

What is delightful is that during the past couple of years, we have seen a clear movement from theory to practice and from laboratories to industry regarding the electrification of NRMM. What is even more promising is that many Finnish companies are active now. To keep up with the newest developments and to sufficiently monitor the field, we would like to warmly recommend continuation of the road map work after the TUBRID! project.

3. *How can a higher-speed electric motor drive be adapted into a low-speed, high-traction force work machine, previously driven by hydraulic motors?*

In demonstration and perhaps in some production cases belt-driven solutions do seem feasible. They may offer space or volume benefits and a wide choice of gear ratio. Both axles have their own electromechanical drive units and there is no mechanical connection between the axles. Electric power is produced by a diesel engine-driven generator and buffered with a li-ion battery. The diesel engine has no mechanical connection to the drivetrain. Powertrain architecture of the hybrid electrical work machine demonstrator is a series hybrid and it is shown in **Figure 11**.

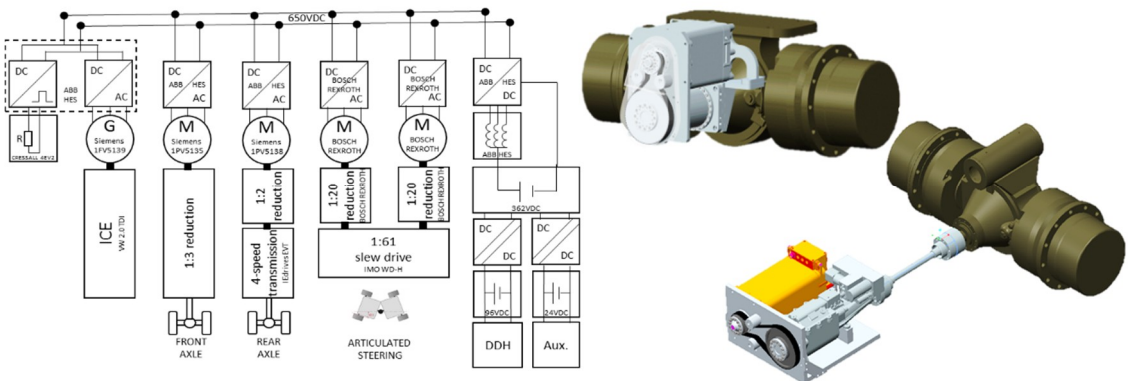

Figure 11. Layout and axles with electric motors, belt drives and gear box.

4. *How will bucket movements be electrified?*

Direct driven hydraulics (DDH), i.e. a solution where one electric motor uses all hydraulic pumps, which are intended for one movement, is displayed in **Figure 12**. DDH combines the benefits of electrical engineering with hydraulics. DDH is utilised to achieve high power density, low-noise and high performance in a compact package for lifting and tilting the bucket of a mining loader. The main benefits of DDH, or what can also be called zonal hydraulics, are:

- Reduction of hydraulic tubing
- Reduction of amount of potential leakage points
- Elimination of some hydraulic components
- Simplification of machine assembly
- Reduction of maintenance cost
- Power-on-demand only
- Independent control of actuators
- Reduced demand for cooling of hydraulic oil
- Reduced amount of hydraulic oil itself on board
- No connection to combustion engine

And of course, there are challenges:

- Increasing number of electric components
- Retrofit to volumetric dimensions of the original cylinders
- Limited volume available in the vehicle itself

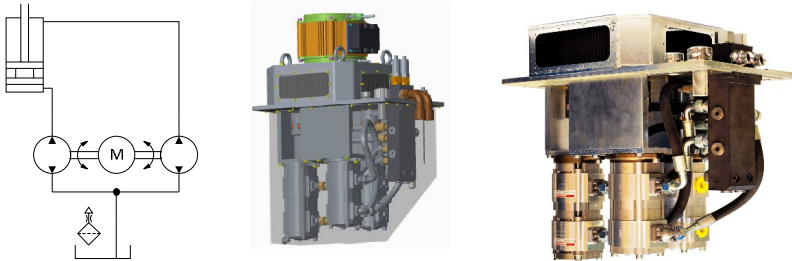

Figure 12. DDH simplified diagram, CAD model and assembly. The voltage is 96 V because the target is to use forklift components and possibly forklift maintenance people, too. When one motor drives individual movements the actual demand of power is not so high i.e. it can be realised with lower voltage and lower cost components.

5. *How can electromechanical pivot steering be realised?*

The main advantages of pivot steering, **Figure 13**, are considered to be in the area of controllability & accuracy & sensitivity.

- Drivers are able to complete driving tasks with very soft and slow movements
- Self-straightening is to be implemented in all loading and driving situations
- Steering degrees can be adapted by driving speed and direction
- Steering speed can be adapted as a function of turning angle
- Automation and remote control of machines will become much more common. Electromechanical steering is one technology to enable no-driver-on-board or even robotised work machines.



Figure 13. Electromechanical pivot steering with two servomotors and worm screw having some self-locking capacity. The behaviour in case of collision is one future question.

6. *How can a combustion engine be downsized without losing performance – buffering with a battery?*

A 2.0-litre diesel engine can be packed into a modular unit with a generator and boosted from a 390 V li-ion battery pack. This solution needs a developed inverter and converter technology supplied by ABB, see **Figure 14**.

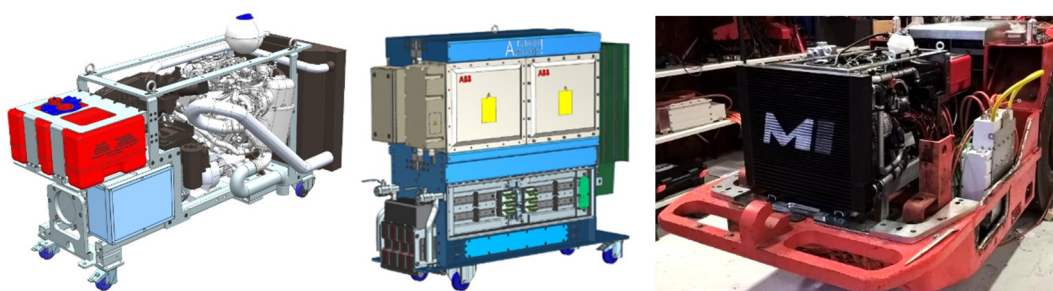

Figure 14. Left: GenSet with controls and small fuel tank; middle: water-cooled power electronics with safety means; right: the GenSet in the hybrid electrical work machine demonstrator. The diesel engine is from VW industrial series.

7. *Is it possible to pack a hybrid electrical powertrain and related equipment in an existing machine without making any changes to the main frame and its dimensions, i.e. using a main frame of an existing machine with conventional powertrain directly?*

This really seems to be the case, as seen in **Figure 15**. From a maintenance point of view, the machine can become rather tightly filled, but this is the situation for many traditional machines as well. It should be remembered that it is not only the batteries, electric motors and gears, but also electric converters and inverters that have to be fitted. If these power electronic components are taken from industrial

applications and are air-cooled, the target may be totally impossible. However, today there are water-cooled devices for mobile applications on the market to fulfil demands.

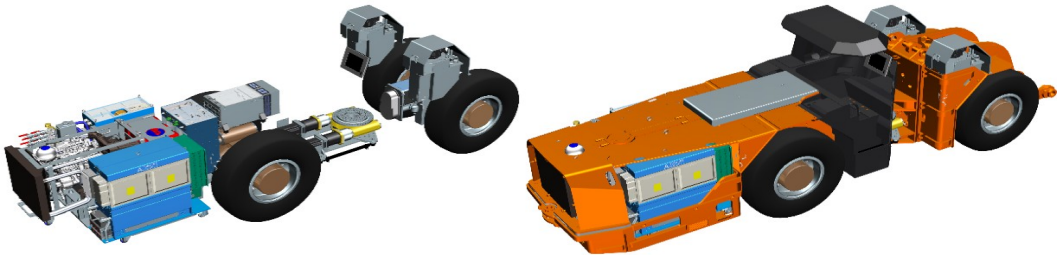

Figure 15. Packaging of hybrid electrical powertrain in an existing machine. DDH units are over the front wheels, which may not be an ideal solution, but it is worthwhile to remember that the demonstrator developed is really a conversion.

2.2.3.4 Exploitation of results from TUBRID I

Using new technology always comes with risks and rewards. For faster introduction and adoption of electric powertrains, it is crucial to have strong:

- Understanding about the cost effectiveness and management of electric powertrains,
- Methods for exploring and validating new design ideas fast (virtual and real test platforms)
- Collaboration between industry, R&D, legislative bodies and end users
- Benefit from technology hypes, e.g., in the consumer market products and public funding and
- Clear understanding of own and good enough understanding of partners' and customers' business models.

Based on the present technology and market situations, it seems that the success of hybrid powertrains will not be determined by the low fuel consumption but more likely by the better controllability, reliability and reduction of maintenance costs. The pure power, i.e. performance will be very important as well. Cost management of the energy storage system and other integrated systems will be important factors.

Results and technological solutions concerning the hybrid electrical powertrain development are now all packed in one machine demonstrator. They might first be applied separately or individually to some special application like DDH to drive some functions.

2.2.3.5 Summary: what happened between 2011 and 2016?

Looking back to year 2011 when project targets and means were set, there have been several changes. All these would have sounded unlikely back then, if they had been written as assumptions.

1. The oil price has dropped dramatically from level 110\$ per barrel down to level 40\$ per barrel. Despite this, lowering energy usage has remained a topic – not major one but a topic. Climate change has demonstrated itself and it has been discussed. General awareness of environmental protection is a topic.
2. The EU economy is still down, including Finland. The downtime has lasted very long and it has affected both industry investments, companies and R&D organisations. The slowdown of China's economic growth might have been brought up, but its impact is not widely understood.
3. Pure battery solutions in buses seem to be the mainstream in development today. It was said back in 2011 that the hybrids would be an intermediate solution on the way to batteries – and that it would last long. In that scenario, a hybrid powertrain would be a means to mitigate range anxiety and risks related to battery technology. However, now we are seriously counting on opportunity charging in buses in urban traffic. The battery technology perhaps did not develop that fast to make this happen. Actual reason for this outcome may be our increased understanding of usage of batteries in different applications that has given us the trust to the battery technology.
4. EU Stage IV came into force. It was perhaps considered that this matter would be handled by engine manufactures as during previous rounds. However, at the end of the day EU Stage IV was a major challenge for many manufactures and took serious work to meet the objectives in adaptation of new engines.

Lesson learned is that the emission legislation is somewhat predictive and it has a major impact on timetables. Moreover, when 2019/2020 comes we will phase the next stage – EU Stage V. We have a couple of years to prepare and seek cost effective ways to meet the demands in terms of customer expectation of ever-increased performance as well as cost effective means to meet emission limits with low maintenance costs.

The publications of the project are listed separately for the whole ECV-project.

2.2.4 Vehicle systems, power grid and charging (eCharge)

Authors: Mikko Pihlatie¹, Riku Pasonen¹, Mikaela Ranta¹, Lasse Laurila², Pertti Järventausta³, Kimmo Kauhaniemi⁴

Affiliations: ¹VTT Technical Research Centre of Finland Ltd, ²Lappeenranta University of Technology (LUT), ³Tampere University of Technology (TUT), ⁴University of Vaasa (UVA)

2.2.4.1 Introduction

The world of electric commercial vehicles is changing rapidly as technology evolves and user adoption increases. Benefits of ECVs have already been studied and research is now focused towards technical aspects (regarding charging in this report), economic feasibility, and business cases.

Tightening emission regulations, increasing costs of fossil fuels, application-related usage restrictions of diesel fuel and overall increase in awareness of climate change and environmental values are some of the governing factors which are motivating commercial vehicle and machinery operators as well as vehicle and mobile machine manufacturers to find alternatives for traditional diesel-operated vehicles in addition to what is happening in public transportation and passenger cars. A potential solution is to use modern battery technologies to store the electrical energy used for driving in different fully electric or hybrid electric vehicles.

The culminating challenges in using this technology are, on the one hand, the limited capacity and high cost of the batteries, and on the other, the integration and grid-connection of these vehicles and machinery into the power grid by charging technology. In the case of commercial vehicles, recharging times must be minimised in order not to reduce the utilisation rate.

Improving the demand side energy efficiency and flexibility is underutilised in the existing power supply infrastructure. In addition to demand side flexibility, often also called the demand response (DR), is increasingly needed as the share of renewable and distributed generation increases. Demand response can also be used as a means for hedging against electricity market failures and price peaks. Flexible charging of EVs, when aggregated with other complementing forms of smart grid technologies has significant potential for achieving system-level reductions in fossil fuel consumption and environmental impacts such as greenhouse gas emissions. EV masses connected to the local electricity network can also enable balancing capabilities and other ancillary services for the local power network when managed intelligently.

2.2.4.2 Result highlights

1. Feasibility of electric buses in public transport

The viability of electric buses in urban transport has been analysed from a systemic point of view through the total cost of ownership (TCO) approach. The concept of

operation with opportunity fast charging of the buses appears to be the most cost-efficient way of designing electric bus systems. Such solutions have the potential to become economically viable for the bus operators. The key issue is to ensure the reliability of operation and availability of the buses and charging systems, which leads to high productivity of these commercial systems.⁵

The buyers' perspective one on economic feasibility. In another study, different charging strategies, different battery sizes and LTO and LFP chemistries were compared. Different combinations have different investment and operation costs. Based on the TCO calculations in one City of Tampere bus route, the most economic combination was suggested; a net present value (NPV) calculation shown below.⁶

Cash flow of the cost of operating line with 4 e-buses (numbers in 1000 €)

Year	2015	2016	2017	2018	2019	2020	2021	2022	2023	2024	2025	2026
Buses	1629	91	91	91	91	91	309	91	91	91	91	91
Infra	224	4	4	4	4	4	4	4	4	4	4	4
NPV	2911											

Cash flow of the cost of operating line with 4 diesel buses (numbers in 1000 €)

Year	2015	2016	2017	2018	2019	2020	2021	2022	2023	2024	2025	2026
Buses	1204	204	204	204	204	204	204	204	204	204	204	204
NPV	3095											

2. Battery technology

Batteries are at the core of electromobility and the single most important component in electric vehicles. In the project, a custom-made battery pack was designed and constructed using quality 18650 cells that were welded successfully together using TIG and laser welding. Also, a cost-effective BMS was developed to a decent prototype phase to be operated in a conversion EV (VW Passat). The BMS development key finding is a simplistic design to easily understand possible points of failure in electronics and easy adaptation to different battery sets. Battery cycle life was tested and a minimalistic cycling device constructed.

3. Charging business models and their profitability

Electric vehicle charging services are costly to build and the customer base to pay for the investments is scarce. EV charging services need to be located at ideally located 'hot spots' where high utility rate is possible. A single charger profitability can be achieved with quite a limited number of daily visits, which implies that the total number of electric vehicles is not crucial.

⁵ Pihlatie, M., Kukkonen, S., Halmeaho, T., Karvonen, V., Nylund, N.-O. Fully Electric City Buses – The Viable Option, Electric Vehicle Conference (IEVC), 2014 IEEE International, DOI:10.1109/IEVC.2014.7056145.

⁶ Vilppo O., Markkula J. Feasibility of electric buses in public transport. EVS28-conference, Korea, May 2015.

4. Charging load modelling in electricity networks

Statistical EV charging load-modelling methodology using national travel survey data has been developed, which is used to create charging load models. Developed models have been used in two distribution network companies (Tampere and Jyväskylä) in real life network planning studies of various future scenarios of EV penetrations in addition to many research studies.⁷

5. Network planning impacts of EV “smart” charging

A smart EV charging algorithm, where charging is controlled for market price-based optimisation or grid capacity usage optimisation has been developed and simulated in cooperation with the ID4AL project.

6. Peak charging load management in real estates

The problematic high load of a charging station group or high total load of high-power charger with domestic electric loads can be controlled in order to obtain a cost-optimal solution and to have also a tool for EV-based DR. Such algorithms have been developed, simulated and demonstrated.^{8,9,10}

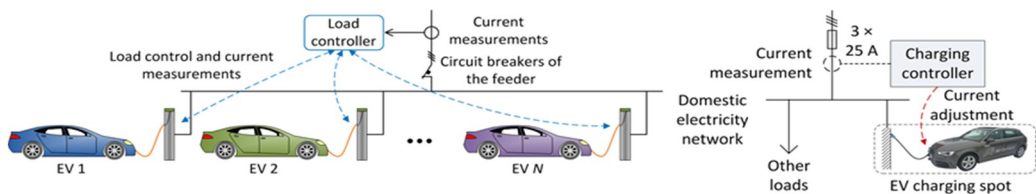

7. EV charging quality measurements and voltage quality impacts of EV charging

Real-life field measurements were conducted for different EVs currently on the market (i.e. Opel Ampera, Nissan NV200-e, Tesla Model S (32A – AC and Super-charger)) by professional power quality measurement equipment. The measurement data and calculation tools for imbalance and harmonic distortion analysis were used to investigate network impacts of EV charging on short-term grid planning to find out what happens if the number of EVs will increase quickly during the next 5 to 10 years.

⁷ Rautiainen A. Aspects of electric vehicles and demand response in electricity grids. Doctoral Dissertation, Tampere University of Technology, 2015.

⁸ Rautiainen A., Järventausta P. Load Control System of an EV Charging Station Group, NORDAC 2014 conference, Stockholm, 8–9.9.2014.

⁹ Rautiainen A., Järventausta P., Tikka, V., Lana, A. Control of electric vehicles charging in domestic real estates as part of demand response functionality. Accepted to CIRED workshop in Helsinki, June 2016.

¹⁰ Rautiainen, A., Tikka, V. Demonstration: EV charging load peak load management in Lappeenranta University of Technology (LUT) 4 Mar 2016.

8. System-level studies of frequency-controlled EV charging and discharging

The potential of aggregated electric vehicle chargers and other energy storages as a power system reserve lies in the fast response time of power electronic devices. The power system model utilised in the study was based on the equivalent model received from Fingrid Oyj. The model of high-power three-phase converters was developed in the project and used for modelling the aggregated electric vehicle charging in system-level simulations. The impacts of frequency-controlled charging as a power system reserve (i.e. frequency containment reserve (FCR-D)) were studied via case studies in PSCAD. If the charging power and G2V/V2G is utilised as a FCR, it is possible to reach a higher frequency minimum after a disturbance in the studied system. Based on the case studies, electric vehicle charging and V2G has potential as a power system reserve. However, since the power of a single electric vehicle charger is small at power system level, it would be necessary to have thousands commercial electric vehicles as an aggregated reserve to meet the current FCR-D reserve capacity requirements set by Fingrid Oyj.

9. Demonstration of frequency-controlled EV charging

Power grid stability requires constant balance between power consumption and power production. Controlling the charging process of EV batteries in an intelligent, coordinated way would provide extremely valuable resource to power system operators. In eCharge, a power grid frequency-based control of EV battery charging was demonstrated and later the concept has been implemented to Liikennevirta Ltd.'s commercial product portfolio.¹¹

10. Demonstration of price signal controlled charging application

Real-life tests of price signal charging were conducted during the project on multiple occasions on the smart charging test bed (modified plug-in hybrid EV). The piloted control scheme used the SPOT price signal to minimise charging cost.^{12, 13, 14, 15}

¹¹ Markkula, J., Tikka, V. Demonstration of frequency controlled charging (Opel Ampera), ECV seminar, Lappeenranta University of Technology, 8 Aug 2015.

¹² Makkonen, H., Tikka, V., Lassila, J., Partanen, J., Silventoinen, P. Demonstration of Smart Charging Interface in Green Campus, EPE'14 ECCE Europe, 16th European Conference on Power Electronics and Applications, Aug. 2014.

¹³ Haakana, J., Tikka, V., Lassila, J., Partanen, J. Analysing the Effects of the Customer-Side BESS from the Perspective of Electricity Distribution Networks, ISGT 2016.

¹⁴ Tikka, V. Lappeenranta, ÄSL – Älykäs sähköinen liikenne, Smart charging [xx] demonstration (Nissan, Mitsubishi, Tesla, Opel + commercial charging poles (minor modifications), communication chain from service provider to car), Mar 2015.

¹⁵ Tikka, V. SGEM Result exhibition, 24 Nov 2014: Smart charging demonstration and poster, Nov 2014.

11. EV charging test bed to test a variety of charging applications

Charging test beds with highly configurable charging schemes and communication platforms were built during the project period. The platform is supported by the Green Campus environment at Lappeenranta University of Technology. The platform has also supported TEKES SGEM, TEKES FLEXE and TEKES EVE ÄSL research projects.¹⁶

12. Communication systems for EV charging

The communication protocols, interfaces and standards relating to the integration of EV charging systems and distribution automation systems are essential from the EV grid integration point of view. The research focused on the interfacing of the ISO 15118-based communication to the IEC 61850-based communication for electricity grid. Relating to this interface there is a new standard coming, IEC 61850-90-8, which was also considered in the work. The data exchange according to the relevant object structure was demonstrated with computer simulations.¹⁷

13. Analysis and modelling of different charging system topologies

Different types of charging system concepts and topologies were thoroughly analysed. As a concrete result, a set of modular simulation models with PSCAD was created. The focus was especially grid-friendly topologies, where power factor correction circuit and suitable filtering was used to avoid power quality issues.^{18, 19}

14. Smart Grid integration of EVs

The behaviour of the energy storage systems, which can also be EVs, were studied especially in the microgrid environment where there is also intermittent renewable energy sources (RES). A decentralised control strategy was developed where the main target is to balance the state of charge of the batteries connected to the sys-

¹⁶ Tikka, V., Makkonen, H., Lassila, J., Partanen, J. Case Study: Smart Charging Plug-In Hybrid Vehicle Test Environment with Vehicle-To-Grid Ability, EPE'14 ECCE Europe, 16th European Conference on Power Electronics and Applications, Aug. 2014.

¹⁷ Gasto, A. Integrating electric vehicles into Smart Grid using IEC 61850 and ISO/IEC 15118 standards, M.Sc. thesis, University of Vaasa, 2016.

¹⁸ Memon, A., Kauhaniemi, K. An Overview of AC-DC Front-Ends for Grid-Friendly Single-Phase-Conductive Two-stage Electric Vehicle Battery Chargers, draft paper ready to be submitted a suitable journal.

¹⁹ Memon, A.A., Kauhaniemi, K. Modelling of grid-friendly charger topologies for electric vehicles. ECV final seminar, Helsinki, 11–12 May, 2016.

tem. Also, the various faults in the charging system were analysed with the simulation models to identify potential safety hazards and adequacy in typical protection arrangements.^{20, 21}

15. Electrification of harbour machinery – TCO of battery-electric machinery

The total cost of ownership of opportunity charging electric harbour machinery was studied to assess the feasibility of the technology. An early feasibility study shows a lot of potential in both a technological and economic sense. Compared to diesel machinery, the TCO of electric machinery is reduced to half due to savings accumulated from using electricity as a fuel. However, the electric machinery utilisation must be high, because better competitiveness is achieved through lower operating costs.²²

16. Prototype charger power quality analysis and modelling

Harmonics analysis on the VTT fully electric prototype bus platform was done to find out the current prototype fits to the quality standards of EN50160, IEC 61000-3-2, IEC 61000-3-4 with Fluke 1760 network analyser. Using the measurements, a simulation model was built with assumption of internal components and logic to Simulink software. The study revealed that harmonics in the prototype charger are high enough to cause power quality problems to the local grid.²³

17. Timetable-based load profile and smart charger control simulation with solar power

Simulations were done with MATLAB Simulink for smart charger power quality management functions such as voltage control and frequency based power control. In addition, solar power directional (azimuth and tilt) production yield was compared against load profiles based on bus schedule, to analyse the possible benefit of solar power in the vicinity of bus depots. The study showed that grid support functionalities are possible to be integrated into the charger without a notable performance effect on actual charging. The direction of the solar panel array could be pointed to show that it matched the morning load peak from bus schedules but there was no direction that could have given similar results for an afternoon load peak generated from bus schedules, see **Figure 16**.²⁴

²⁰ Palizban, O., Kauhaniemi, K. Distributed Cooperative Control of Battery Energy Storage System in AC Microgrid Applications, *Journal of Energy Storage*, **3**, 2015.

²¹ Palizban, O., Kauhaniemi, K. Power Sharing for Distributed Energy Storage Systems in AC Microgrid: Based on State-of-Charge, *IEEE PES Asia-Pacific Power and Energy Engineering Conference (APPEEC 2015)*, November 2015, Brisbane.

²² Raitaluoto, T. Prerequisites of high power charging infrastructure and fully electrical machinery implementation in harbour environment, Master's thesis, Aalto University, Espoo, Finland, 2015.

²³ Pasonen, R., Pykälä, M-L. eCharge – eBus Prototype Charger Measurement and Simulation. Research Reports: VTT-R-03822-15.

²⁴ Pasonen, R., Löf, A. Methods for power quality management in electric vehicle depot charging. Poster presentation at ECV Final seminar.

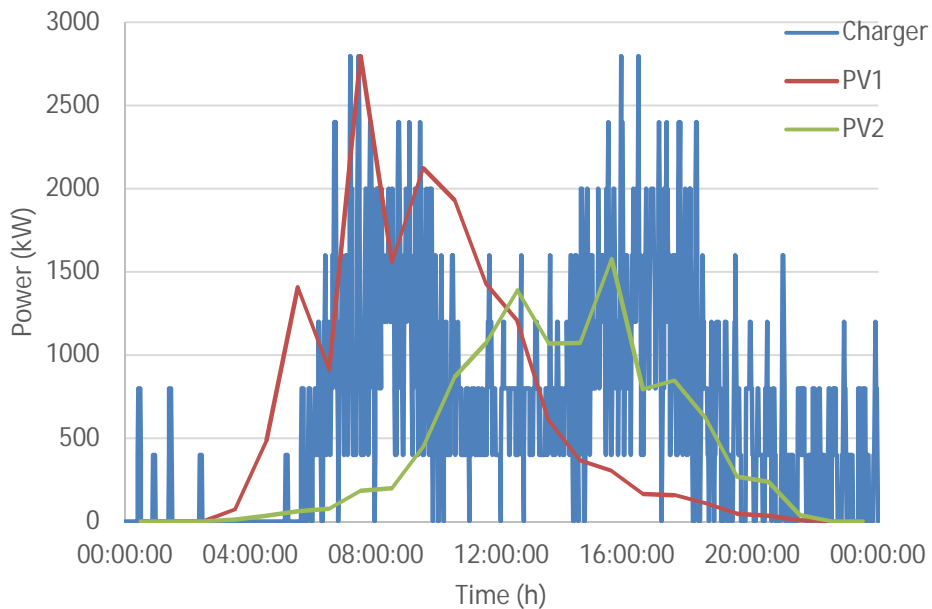

Figure 16. PV panels aligned to east (the red line) and west (the green line).

18. Simulation methodology and tools to aid planning of electric bus systems

Implementing a fleet of electric buses can be a challenging task for the transport system as a whole and generates loads for power grids. This opens interesting opportunities for dialogue between power system design, electric bus routes and concept planning and development. Further, the vehicles and electric powertrains need to be designed and optimised for the operational system requirements and duty cycles. Productivity, reliability and availability need to be secured in terms of key performance indicators at system level, including also issues on energy and charging management, system-level scalability, interoperability and prioritisation.

A suite of cooperating tools was created to study this interaction, combining a power-grid-connection cost model, a route design and drawing tool, and a tool to simulate different kinds of electric buses driving along the designed routes and charging energy from the specific infrastructures. The analysis takes also into account the different concepts of charging (overnight depot charging or fast opportunity charging), as well as the times available for charging within the vehicle rotation scheme and timetables specified by the public transport authority (PTA) and the bus operator.

Both existing and new bus routes can be designed in the route design tool and chargers can be placed on any desired location. In the simulations, the speed profile is dynamically created taking into account a given bus schedule, bus stops, curves, speed limits, traffic and traffic lights, see **Figure 17**. Different types of buses can be

simulated and compared to each other. The results obtained from simulations correspond well to measured data obtained in the Helsinki region. The tool can be used for planning the bus operation and for estimating investment and operating costs of a proposed system design. With the help of simulations, an optimal system design with minimised costs can be achieved. Future work will combine the separate tools into a joint simulation platform with a convenient user interface. Viability of a tool like this relies on availability of data and preferably open data. Finland has made good progress in open data but there is still work to be done on this theme.²⁵ Alongside with the research tasks, VTT has carried out several comprehensive analyses on mapping out the potential and analysing the best options to implement fully electric bus systems, using the methodology developed in the ECV project²⁶.

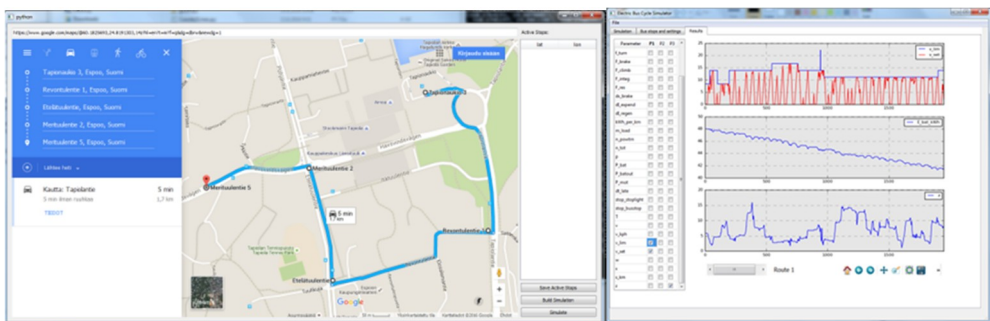

Figure 17. Geographic information system (GIS) based tool and methodology for design and optimisation of electric commercial vehicles systems (vehicle, operation and charging) through simulation.

2.2.4.3 Discussion

Electricity is a promising fuel alternative for transportation, however, it will not be the ideal solution applicable generally for all systems and use cases. The powertrain alternatives in terms of a varying degree of hybridisation (micro hybrid – mild hybrid – heavy hybrid – rechargeable plug-in hybrid) in combination of an internal combustion engine (ICE) with several fuel options and exhaust classes, or a range extender such as a fuel cell system offer a wealth of options.

Many use cases such as logistic chains, refuse trucks, maintenance and utility vehicle fleets etc. were not analysed in sufficient detail in order to conclude on their specific optimal systemic implementations, operation concepts and charging technologies. Inductive charging was also not given much effort but rather the development of current technologies. Generally, interoperability within and between vehicle

²⁵ Ranta, M. et al. Method Including Power Grid Model and Route Simulation to Aid Planning and Operation of an Electric Bus Fleet, 2016 IEEE Vehicle Power and Propulsion Conference (VPPC), Hangzhou, 2016, pp. 1–5. doi:10.1109/VPPC.2016.7791724.

²⁶ Ranta, M. et al. Feasibility of electric buses in Tromsø, VTT Customer Report VTT-CR-04106-16, 30.9.2016 (publicly available upon request).

types and classes as well as standardised solutions for charging will be important in the future.

With smart charging, the generalisation of EVs is going to impact the electrical grid to a much lower degree decreasing costly disturbances. For vehicles, which are not in high duty and opportunity charging modes of operation, the timing of the charging can also be optimised to take place during low-cost hours, which saves money for the consumer and balances grid load.

As technology matures in the field of ECVs, their cost-competitiveness will improve and the cost-benefits will only increase. Currently, there is still a place for traditional diesel technology in some application areas, but in the future, that could change as well, at least through hybridisation.

EVs will no doubt be one of the major active resources from the smart grid ecosystem perspective and there will be many business and optimisation possibilities for mutually beneficial business cases. These can, for example, be the studied frequency support service, optimised fleet charging in electricity market, and joint ventures in infrastructure like installation of PV panels in bus depot roofs.

2.2.4.4 Acknowledgements

The authors would like to express thanks to Caruna Oy for supplying power grid data for the operation tool development.

2.3 The international context

The ECV project entity has had the major focus in developing the national projects and activities as well as creating the public-private partnerships and research & development networks in Finland. The natural aim for such projects funded by Tekes is new products and businesses for Finnish industry. However, in co-operation between the partners in research, academia and industry, the international context and co-operation is of vital importance. In the following a few international activities or relevance to the project and running parallel with the ECV activities are listed.

2.3.1 Zero Emission Urban Bus System – EU ZeEUS

2.3.1.1 Vision

Testing electrification solutions is at the heart of the urban bus system network through live demonstrations and facilitating the market uptake of electric buses in Europe. ZeEUS²⁷, the Zero Emission Urban Bus System, aims to be the flagship EU project to extend the fully electric solution to the core part of the urban bus network. It follows recommendations from fellow UITP European bus system projects [EBSF and 3iBS] to apply the electric solution to urban bus systems.

²⁷ The ZeEUS website, <http://zeeus.eu/>, accessed on 22.4.2017.

The project fits within the context of the European Commission's objective to create a competitive and sustainable transport system by deploying alternative fuels to reduce transport emissions and improve air quality and noise levels in urban areas. To achieve its mission, ZeEUS will test a wide range of different innovative electric bus technologies and charging infrastructure solutions in ten demonstration sites across nine European countries with varying operational conditions to validate their economic, environmental and social viability.

The ZeEUS consortium comprises the entire stakeholder spectrum that represents all of the key actors and decision maker categories who will facilitate the process of extending the electric solution to the core urban bus network. The 40 partners represent Public Transport Authorities, Public Transport Operators, Industry and Vehicle Manufacturers, Energy Providers, Universities and Research Centres, Engineering Firms, Consultancies and Associations.

Moreover, the ZeEUS project aims to be the flagship electric bus project that will also closely follow the development of electric bus systems all around the world through the ZeEUS Observatory. Selected and Monitored Demonstrations will directly contribute to some of the core ZeEUS activities and strategic outputs.

2.3.1.2 Objectives

The key objectives of the ZeEUS project are to:

- Extend fully-electric solutions to the core part of the urban bus network composed of high capacity buses;
- Evaluate the economic, environmental and societal feasibility of electric urban bus systems through live operational scenarios across Europe;
- Facilitate the market uptake of electric buses in Europe with dedicated support tools and actions;
- Support decision-makers with guidelines and tools on "if", "how" and "when" to introduce electric buses.

2.3.1.3 VTT's role

VTT is a key member of the global evaluation team that is responsible for setting the key indicators and developing measurement plans for the demonstrations together with local partners. The global evaluation team will also analyse data and make 'demo-specific' data transferable to produce a generic knowledge base for electric bus technologies and operations.

Part of VTT's activity is related to grid effects of electric bus charging systems. In addition, VTT has an important role in the standardisation efforts for electric bus charging systems that is being advanced under the auspices of the ZeEUS project.

2.3.1.4 Summary

- Scope: Testing electrification solutions at the heart of the urban bus system network through live urban demonstrations and facilitating the market uptake of electric buses in Europe.
- Duration: Nov 2013–April 2018 [54 Months]
- Budget: 22.5 MEUR (13.5 MEUR EU-funding)
- Number of partners: 39
- Coordinator: UITP, the International Association of Public Transport

2.3.2 The European Bus System of the Future 2 – EBSF_2

2.3.2.1 Vision

The European Bus System of the Future 2 (EBSF_2) project²⁸ is led by UITP and co-funded by the European Union's Horizon 2020 research and innovation programme. The project capitalizes on the results of the previous EBSF project (September 2008 – April 2013). EBSF_2 is aimed at developing a new generation of urban bus systems by means of new vehicle technologies and infrastructures in combination with operational best practices, and testing them in operating scenarios within several European bus networks.

The distinctive factor of EBSF_2 is the consortium's ambition to improve the image of the bus through solutions for increased efficiency of the system, mainly in terms of energy consumption and operational costs, as required by today's economic situation.

The need for more cost-effective and energy-efficient bus systems has led to the identification of a set of technological innovations and strategies with a strong potential to optimise mainly energy and thermal management of buses (in particular auxiliaries such as climate systems), green driver assistance systems, intelligent garage and maintenance processes, IT standard equipment and services. Moreover, to effectively address the need to move quickly from laboratory research to actual innovation of the bus fleets in operation in Europe, the solutions to be tested have been selected according to their technological maturity (and not only because of their potentiality) in order to ensure a short step for commercialisation after the end of the project. The use of simulators and prototypes has been conceived as a preliminary step for the validation of the innovations in real operational scenarios, performed also within the project, or as a necessary task to prove the potential of more futuristic solutions currently implemented at early stages of development (e.g. modular bus).

The commitment of the main European bus manufacturers combined with the presence of top-leaders suppliers and large operators with worldwide experience lead to expect that the results of the project will have an important impact on urban bus services. Their joint collaboration is believed to produce high quality products

²⁸ The EBSF_2 website <http://ebsf2.eu/>, accessed on 22.4.2017.

for the next bus generation, strengthening the leading role in the world of the European bus industry and paving the way for the possible development of standard concepts. As the main impact of EBSF_2, the partners expect to observe the overall increase in the attractiveness of bus systems and the economic benefit with regard to the total operational costs.

2.3.2.2 Objectives

By 2050, around 65% of the global population will live in cities. A growing group of urban citizens poses a big challenge for already congested and densely populated urban areas. The best solution to the growing demand for mobility in densely populated areas is public transport as it offers the most efficient travel in terms of urban space and energy consumption per traveller.

In spite of genuine innovations in the field of bus manufacturing over the recent years, user acceptance of bus transport has not duly changed. Furthermore, the economic situation today calls for further development of selected research areas to make bus systems more attractive for passengers and, at the same time, more efficient and economical to operate.

In the frames of the EBSF_2 project, innovative solutions for urban and suburban bus systems are tested and evaluated in order to improve the efficiency of operations and the image of the bus. By involving 12 demonstration sites, see **Figure 18**, with more than 500 vehicles, the project intends to validate in real operational scenarios the potential impact of technological innovations – almost ready for application – and develop efficient answers to both citizens and bus stakeholders' needs.

2.3.2.3 VTT's role

VTT is in charge of one demonstration (of altogether 12) that is involving two different technical innovations (TI) that are related to improved energy management of auxiliaries in an electric bus as well as a driver assistance system that is set to help the driver drive energy efficiently and keep the timetable. Both of these systems will be demonstrated in electric buses driving in Espoo and Helsinki. VTT has also a role as a Technical Research Advisor (TRA) in the area of energy use and energy management

2.3.2.4 Summary

- Scope: Advancing solutions for improved efficiency and attractiveness of urban bus systems
- Duration: May 2015–April 2018
- Budget: 12.4 MEUR (10 MEUR EU-funding)
- 42 Partners
- Coordinator: UITP, the International Association of Public Transport



Figure 18. EBSF_2 Demonstration cities.

2.3.3 Nordic co-operation of transport authorities

Nordic Energy Research²⁹ (NER) operates under the Nordic Council of Ministers and is a forum for strategic and policy-oriented Nordic research in the area of energy. Transport and electrical vehicles have attracted attention at NER. NER has co-organised and sponsored two Nordic conferences on electric buses. The first Nordic Electric Bus Initiatives conferences was organised by Lindholmen Science Park in Gothenburg, Sweden on September 1–2, 2015³⁰. A second conference, Nordic Electric Bus Initiatives II³¹ was organised by VTT on May 11–12, 2016. The NEBI II conference also coincided with the final seminar of Electric Commercial Vehicles.

There is a considerable interest in the Nordic countries to implement fully electric bus systems in urban transport. All countries have demonstration or pilot projects ongoing and the first commercial tenders on electric bus systems are at hand. The following will summarise results from exchange and best practices worked out together with the main Nordic cities.

²⁹ <http://www.nordicenergy.org/>

³⁰ <http://www.nordicenergy.org/event/nordic-electric-bus-initiatives-event/>

³¹ <http://www.nordicenergy.org/event/nordic-electric-bus-initiatives-ii-helsinki-11-12-may/>

2.3.3.1 Best practices for acquiring opportunity-charged electric buses

Authors: Mikkel Krogsgaard Niss¹, Jon Stenslet², Reijo Mäkinen³, Maria Övergaard⁴
Affiliations: ¹City of Copenhagen, ²Ruter, ³Helsinki Region Transport, ⁴Stockholm County Council

This note describes the best practice for acquiring electric opportunity charged buses (eBuses) and charging equipment in the Nordic countries. Best practices are based on acquiring processes in Copenhagen, Stockholm and Helsinki and a pre-tender process in Oslo. An expert group with experts from the four major capitals has given input to this note. All Public Transport Authorities (PTA's), cities and private companies can use this note in their procurement processes. This note deals only with opportunity charged buses. Overnight charged buses are not addressed in this note.

Framework

Three models have been used for acquiring opportunity-charging buses in Copenhagen, Stockholm and Helsinki.

1. Direct procurement for test and development – Helsinki
2. Cooperation project without direct procurement – Stockholm
3. Public procurement (tender) of buses and charging equipment – Copenhagen

Risk handling and payment to/from the operator are different in the three models.

1. Direct procurement for test and development

HSL, the Public Transport Authority (PTA) in Helsinki region and the cities of Espoo and Helsinki have decided to test electric buses with opportunity charge in a pre-commercial pilot project, prior to open commercial tendering.

The two cities have bought charging poles and charging equipment for the cities directly from Heliox/Schunk (Direct Procurement). The PTA has made a direct procurement of 12 electric buses from the manufacturer (Linkker bus). Direct procurement is only possible for small projects (less than about 200.000 €) and for test and development projects. This project is a test and development project. The reason is that when the buses and charging equipment were acquired, only very few e-buses were available on the market.

Direct procurement has many advantages for test and development projects, but is not available later in the roll-out of the technologies. In this project, direct procurement makes it possible to form a close partnership between the manufacturers, the PTA and the cities. The expert group finds that direct procurement is not available anymore, since the market has grown with many serious suppliers of buses and charging equipment.



Figure 19. Linkker bus belonging to the HSL pre-commercial pilot project 'ePELI'.

Risk handling

The operators are not interested in taking extra risks in the introduction of new technology. For that reason, HSL has purchased the 12 electric buses directly from Linkker and lends them out to commercial bus operators to be used inside existing contracts. This is an exception since the operators typically buy the buses. HSL takes the risk of technology from the electric buses, because it would be unreasonable for the bus operators to have all the responsibility and the technological risk. The goal of the project is to be a pilot project for a larger electric bus system. In addition, HSL tests more detailed electric bus specifications and introduces the idea of electric buses to bus operators. The 12 electric buses are 'extra' vehicles, so possible problems will not affect the service level of the bus system.

Each of the four largest operators can test two buses delivered by the PTA. The operators buy the buses from the PTA for 15% of the actual price. The last four buses will be distributed later.

No incentives are given to the operators except that they can buy electricity at normal rate (about 0.10 €/km). The cost of diesel is about 0.40 €/km. The two first buses were delivered in November 2015. Total price of 12 buses and 6 charging posts was 6.6 million €.

2. Cooperation project without direct procurement

In Stockholm, they were testing plugin hybrid for a complete line (8 buses). The test is a part of the ZeEUS EU-project. ZeEUS Stockholm is a cooperative project demonstrating electric hybrids, between Volvo, Vattenfall, SLL (Stockholm County Council (Transport Administration)), and Viktoria Swedish ICT. In the project, Volvo contributes with the buses, Vattenfall with charging, SLL pays the added costs for

the operator and slow chargers at the depot, and Viktoria Swedish ICT is the “academic part”, a research institute that is part of the ZeEUS evaluation WP.

Acquisition process

The operator is, according to the traffic operation agreement, obliged to take part in development projects initiated by SLL (the PTA). They have the right to be compensated for extra costs.

After the procurement of the traffic operation was finished, SLL made an agreement with Keolis to operate line 73 with the eight electric hybrid buses. Volvo and Keolis made a bus leasing agreement, Vattenfall and Keolis made an agreement for delivering electricity for use by Keolis. There were also cooperation agreements between Volvo, Vattenfall and SLL, as well as an implementation agreement between the former and Keolis. These are not all the agreements needed, as seen in **Figure 21**. The latter two agreements each took about a year to finalise, so giving enough time for this part of the process is also an important lesson learned.



Figure 20. Plug-in electric bus in Stockholm.

The buses in Stockholm are acquired directly from the manufacturer by the bus operator. The PTA has facilitated the contact between the bus manufacturer, the charging manufacturer and the bus operator. Since the project is supported by the EU, the price for the operator is equivalent to the price of gas buses. The bus operation is only supported by the EU during the first two years. After these two years, the bus operator is able to return operation to gas buses, if operation is less smooth than expected. The contract between SLL and the operator is 10 years, **Figure 22**.

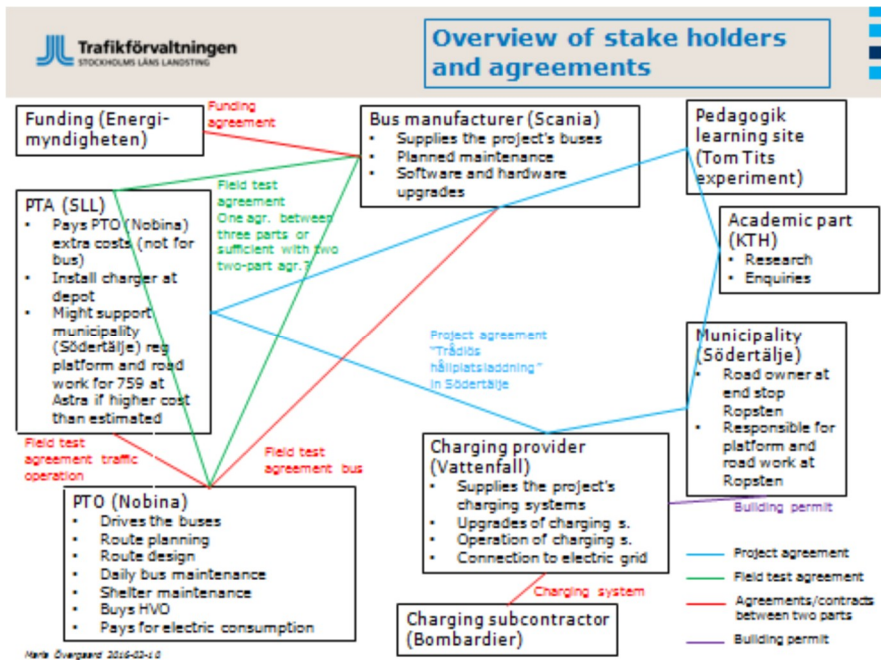

Figure 21. Co-operation links and agreements between the different stakeholders in the Stockholm project.

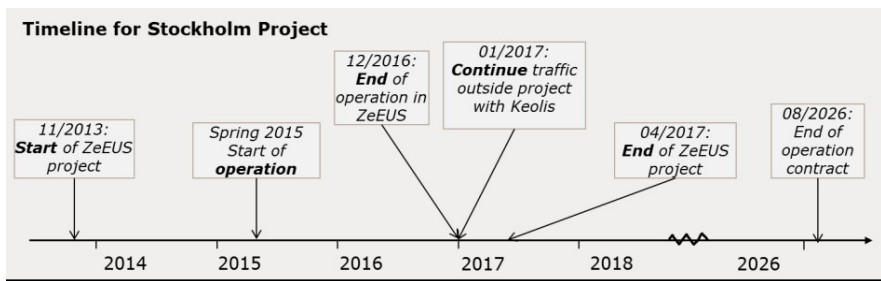

Figure 22. Timeline for the Stockholm project.

The acquisition is made after a normal bus operation tender but before the start of operation. This makes it possible for the bus operator to buy the hybrid buses. On one hand, the buses drive as they would in normal operation since there are no backups if the buses are malfunctioning. On the other hand, it is a demonstration project with financial support from the EU.

Vattenfall is the charging operator and the charging equipment is delivered to Vattenfall by Siemens. The bus operator only pays Vattenfall for electricity, but the price is unknown to SL.

The same setup is currently being used for a new bus route with inductive charge. This trial is however with only one hybrid bus and one charging station. The bus manufacturer is delivering the bus and charging equipment at a price as if it were a biogas bus. Scania contributes with one bus, Vattenfall with building and maintaining the charging station at one end stop, SLL with the extra costs for the operator and slow chargers in the depot. The Royal Institute of Technology, KTH, is the academic partner. In this project, the municipality is a more involved part and builds the bus stop platform. This project is partly financed by the Swedish Energy Agency.

Risk handling

Since both projects are based on normal bus operation contracts, the bus operators have all risks in case of malfunctioning. The bus operators have made it possible in their agreements with the bus manufactures to change buses after the first two years, if the buses are working worse than expected.

Lessons learned

In demo projects, choosing the route might be tricky. The route and the buses have to fit each other and there needs to be enough vacant electricity in the grid. Charging infrastructures require more space than expected. This is not only the case above ground, but also underground, where the foundation to the charging pole is quite large.

It is important to take enough time when tendering electric bus operation. It is too late to introduce e-buses when a tender is decided, so all major decisions have to be made prior to the tender process. It takes a lot of time to initiate a demo project. In Stockholm, the project has taken three years from the first contact between SLL and Volvo to the start of operation of the buses. Demo projects are easy compared to real operation. The business models are harder to decide on than hardware, and the real question is how to organise infrastructure ownership, bus ownership and interface between the bus and charger.

3. Public procurement (tender) of buses and charging equipment

Copenhagen is currently testing opportunity charged eBuses from 2016 to 2018. The buses are to be tested at route 3A, a route with 9 km between terminal stops and 4 min average waiting time at terminal stops. The total budget for the trial is 11 million DKK (1.5 million €). The trial is a cooperative project between the City of Copenhagen (lead), Movia, E.ON and the Danish Transport Authority.

The Copenhagen trial was initiated later than the projects in Helsinki and Stockholm. A pre-study conducted in 2014 showed many possible bus manufactures (Volvo, Solaris, VDL, and Ebusco among others) and charging equipment (Bombardier, Siemens, ABB, and Heliox). Because of the existence of a real market, the City of Copenhagen assessed that public procurement was the only legal way of acquiring the buses.

Acquisition process

The city wanted on one hand to have an innovative partnership with the manufacturers and on the other hand to make an open and fair public procurement of buses and charging equipment. The tendering process was formed as a tender with negotiation. The prequalification was in March 2015 followed by the main tender from April to October 2015. Five bidders made the final bid. To make sure that charging equipment and buses work together, only one tender was made. The bidders were asked to form consortiums of bus and charging manufacturers.

The scope of the trial was that the buses should run at the existing time schedule. Furthermore Copenhagen wants to test the buses at the heaviest circulation plans to make sure that they are able to run in any circumstances in Copenhagen. A number of other demands were set up in the tender document:

- Able to run for 4 hours with only one functional charger
- Maximum battery size: 120 kWh
- Maximum noise from charger: 55 dB(A), 1 metre from charger at 1.8 metre height
- Maximum noise from connecting the charger: 55 dB(A) at 10 metres
- Maximum noise inside the bus: 68 dB(A)

Since this project is a trial, Movia (PTA in Copenhagen) has reduced some demands for buses (passenger capacity, automatic fire extinguisher, IT cabinet, platform, kneeling and more). The bids were evaluated by a number of relevant factors:

- Price
- Energy efficiency
- Uptime
- Connection noise – max 55 dB @ 10 metres
- Delivery time
- Internal noise – max 68 dB
- Passenger capacity
- Emissions
- Battery lifetime
- Flexibility regarding chargers
- Urban space integration

Electric buses have no SORT-test and no standardised calculations of battery lifetime and energy efficiency. Furthermore, uptime, delivery time and emissions are impossible to confirm prior to evaluation of the bids. Energy efficiency was evaluated based on the estimates from the bidders. Any deviation from the energy efficiency stated in the bid will be regulated in the final payment rate. Battery lifetime, uptime, delivery time and emissions were accepted as stated by the bidders. When the project ends after two years, these factors will be evaluated and published. If the bidder is not able to live up to their promised values, this will be stated in a report. It is the impression of the evaluators that all bidders had fairly credible bids.

Elements like smart solutions, acceleration noise, noise at specific frequencies and passenger flow were not evaluated.

Risk handling

In Copenhagen, two major risks are present.

1) The buses or charging equipment may not work when delivered. No payment is made prior to satisfactory delivery. Payment will only be made if the buses live up to the promised specifications.

2) The OEM may not comply fully with the promised factors regarding noise, energy efficiency, etc. Element measurable on delivery will be measured. The buses will only be accepted as satisfactory if they comply with the specified factors.

Some factors are not measurable and will therefore only be measured during the trial and after the end of the trial. These factors will, if possible, be solved during the trial. In the final report, these factors will be mentioned. As a result, the OEM has an incentive to live up to the promised factors.

Lessons learned

The tender was evaluated based on different figures. However, some of these figures were only promises from the OEM's and the City of Copenhagen was not able to test if these figures were true during the tender evaluation. If the tender was to be done again, some of these figures would be excluded and for rest the bidders would be asked to support their figures with some kind of explanation. In the evaluation, the explanation would then be included.

The tender was a tender with pre-qualification. Seven consortiums were approved in the pre-qualification. However, these companies had very different financial capabilities and experience. In evaluation of the tender financial capability and experience was assumed equal for all bidders. The risks associated with contracting with a smaller and less experienced company could have some weight in the evaluation of the final bids.

Noise was evaluated in the same way as for a diesel bus (noise level inside the bus at 50 km/h). Some electric buses are especially quiet when accelerating, while the noise at 50 km/h basically consists of wind and tyre noise. Furthermore, some electric buses had an annoying high frequency noise. Noise during acceleration and at certain frequency bands should be included in the tender evaluation.

Passenger flow and passenger capacity are opponents. If the bus has many doors, fewer seats are available. Furthermore, some buses use a lot of space for batteries making less space available for passengers. Therefore, the number of seats is very important and different from OEM to OEM. How to evaluate bus layout, doors, seats, etc., should be very clear for the bidders in the tender documents. Smart solutions are difficult to include in the tenders and should either be excluded in the tender or added as some kind of option to buy afterwards.

The bidders are typically not dealing with cities and PTA's. They are not used to making bids and to read or write public procurement documents. This means that

almost no bids met the minimum requirements at the first bidding round. Negotiations are really important to make sure that the bidders meet the minimum requirements.

How to include e-buses in tenders of bus operation

The difficult part of getting e-buses to run on a larger scale is the business models. Who owns the buses, who owns the batteries and who owns the charging equipment? And further, who operates the buses and the charging equipment?

Seen from the cities and the PTA's there is a risk, if charging equipment, batteries and buses are owned and/or operated by different entities. If something is out of order, they may blame each other if everything is well contractually coordinated.

Seen from the bus operators, there is a risk dealing directly with a charging operator (owner and operator of charging equipment). If the charging equipment is not working (or not working with the buses) then the bus operator will get a fine from the PTA because of cancelled bus operation.

Furthermore, charging equipment has a long depreciation time compared to buses. The existing contracts in the four capitals, cannot handle contracts where charging infrastructure will be depreciated during 15-20 years.

If opportunity charged eBuses are to be introduced in the larger cities, some have to take the risks. In the long run, solutions where a charging operator owns and operates the charging equipment are expected, but for the present, the risks for the bus operator are too high. Until then cities or PTA's could:

1. Make separate tenders for charging operation and bus operation. In this way, charging operation is separated from bus operation and some of the risks are handled by the charging tender. Some communication problems will probably occur.
2. Own buses and/or charging equipment. If the city or the PTA owns the charging and bus equipment and includes operation of these buses in a tender, the risks of malfunction in the communication between buses and chargers are reduced and handled by the city or the PTA.

3. Battery technology and applications

3.1 Electrical and thermal characterisation of large lithium-ion batteries

Authors: Ari Hentunen

Affiliations: Aalto University

Current contact information for main author: ari.hentunen@vtt.fi

Abstract

The characterisation of lithium-ion batteries is a time-consuming task, because very slow dynamics are present and the characteristics are strongly affected by the state of charge, discharge rate, and temperature. This paper demonstrates the use of an efficient and effective semi-empirical characterisation methodology for direct characterisation of electrical and thermal properties of a commercial lithium-ion battery module. The capacity, open-circuit voltage, internal impedance, entropy change, and thermal properties are characterised by using two types of experiments: (i) galvanostatic intermittent discharging and charging and (ii) continuous thermal loading. Module-level characterisation results in a low-order model that can be scaled for any battery pack configuration. The use of the characterisation methodology is demonstrated for a commercial lithium-ion battery module and the model is validated with a real-world duty cycle.

3.1.1 Introduction

Lithium-ion (Li-ion) batteries are used in a wide range of applications, ranging from handheld electronics to hybrid and electric vehicles and non-road mobile machinery (NRMM) as well as stationary battery storage systems for renewable energy systems and smart grids. The battery is a critical component of an electric NRMM, because it determines mainly the real performance of a vehicle and affects significantly the cost and weight. The development of a battery system is a challenging task, because the performance depends on the temperature, state of charge (SoC), and aging. The sizing and selection of the battery pack is difficult, because the cell specification cannot answer the following question: Is the battery pack capable of meeting the performance targets for a specific duty cycle under repetitive use?

The large battery packs for commercial vehicles and NRMM are exposed to heavy duty use, in which the battery encounters repetitive high power peaks, high average power, and harsh ambient conditions with very limited rest time during a day. Hence, the electrical and thermal performance of the battery module and pack must be assessed thoroughly during the development of the battery system. The performance can be assessed either experimentally or by a model-based approach, in which the battery is first characterised experimentally, and the resulting parameterised battery model is then used to assess the battery performance at all operating

conditions. The experimental approach is very tedious, time-consuming, and expensive. The adoption of the model-based approach saves time, effort, and cost significantly during battery development.

This paper gives a brief demonstration of the developed battery characterisation methods³² and discusses the applicability and advantages of using such methods for the development of electric commercial vehicles (ECVs).

3.1.2 Characterisation of batteries

Batteries are highly nonlinear and complex electrochemical devices. The battery modelling approaches can be generally divided into electrochemical, mathematical, and electrical modelling. Electrochemical models are complex white box models that characterise the fundamental processes that occur inside the battery, particularly the processes at the electrodes and the electrolyte. The electrochemical models are mainly used to optimise the physical aspects of batteries and to characterise the fundamental properties of batteries. The parameter extraction is difficult and impractical, because detailed proprietary information about the inner construction of a battery cell is needed. Mathematical models are abstract black box models with high complexity, and they are typically used to predict system-level behaviour such as remaining capacity, runtime, and efficiency. Electrical models are grey box models that use electrical equivalent circuits to mimic the battery's electrical behaviour. Recent electrical models can be divided into Thévenin-based³³ and impedance-based³⁴ electrical models. Parameters of impedance-based models are extracted based on electrochemical impedance spectroscopy measurements in the frequency domain, while Thévenin-based models are parameterised using time-domain data from intermittent discharging and charging experiments. Both modelling methods may also need additional experiments such as constant-current discharging and charging experiments at a low rate for extracting the capacity and open-circuit voltage (OCV) characteristics. The computational complexity of electrical models is low in general and depends on the order of the model. The model can be augmented so as to also predict the temperature. Electrical models are commonly used for system-level simulations of electric vehicles (EVs) and performance assessment of batteries. Thévenin-based models are attractive, because no impedance measurements need to be done. In addition, also battery modules and packs can be characterised and modelled directly based on the data from a battery cycler during performance tests of a battery module or pack.

³² Hentunen, A. Electrical and thermal characterization of large lithium-ion batteries for non-road mobile machinery applications, D.Sc. (Tech.) dissertation, Aalto University, Helsinki, 2016.

³³ Chen, M., Rincón-Mora, G.A. Accurate electrical battery model capable of predicting runtime and I-V performance, *IEEE Transactions on Energy Conversion*, **21**(2), 504–511, Jun. 2006.

³⁴ Buller, S., Thele, M., Doncker, R.W.A.A.D., Karden, E. Impedance-based simulation models of supercapacitors and Li-ion batteries for power electronic applications, *IEEE Transactions on Industry Applications*, **41**(3), 742–747, May/Jun. 2005.

Thermal modelling of batteries can be separated into two tasks: (i) modelling of the heat generation, and (ii) modelling of the heat-transfer dynamics. The heat generation rate of a battery comprises of the irreversible heat and reversible heat, in which the irreversible heat is associated with the internal resistance and the reversible heat is associated with the entropy change in the electrodes resulting from structural changes caused by intercalation of lithium ions during charging and discharging. These structural changes can release or absorb heat, depending on the electrode materials, SoC, and direction of the current. The entropy change characteristics are strongly dependent on the materials and composition of the electrodes. The characterisation of the entropy change takes several weeks to complete using a conventional potentiometric method^{35,36}. Heat generation can be modelled with electrochemical models or with electrical models, which may include or exclude the reversible heat generation. Heat-transfer dynamics of a battery cell are dictated by material properties, i.e., the specific heat capacity and mass of the battery, the heat-transfer coefficient of the battery, and the surface area of the battery. The battery can be treated as a lumped model with a single homogeneous material with averaged properties, or as a more detailed model structure, which can include the battery geometry. The latter can be implemented, e.g., with a finite element method (FEM) and dedicated software. Furthermore, when considering a battery module, the cooling affects strongly the heat-transfer dynamics. Numerical methods such as FEM and computational fluid dynamics are preferred for the thermal design and detailed thermal investigation of battery modules and packs. However, for evaluation of the thermal performance and for system-level modelling purposes, a lumped-parameter model is often preferred due to its simplicity and easy applicability.

Cell-level testing is the simplest and fastest approach to characterising batteries. Single cells are easy to order, deliver, and handle. The voltage and power ratings of the electronic load and power supply are also low, and therefore, the price of the equipment is low. In addition, no battery management system (BMS) nor other auxiliary electronics are needed, which makes it easy to set up the experiment. A module-level testbed is typically used for commissioning of the BMS and verification of its functionality as well as to assess the electrical and thermal performance of the battery module. Especially the thermal performance needs to be assessed carefully at the module level, because the packaging and cooling system affect the thermal characteristics of the module. The price of the module-level testbed is moderate, the power requirement for the battery cyclers is in the order of kilowatts or tens of kilowatts. Pack-level battery cyclers are very expensive. Full-scale batteries for NRMM and commercial vehicles are also expensive to obtain for evaluation purposes. In addition, the delivery, handling, and setting up of the experiments are time-consuming. Hence, the experimental testing of battery packs is typically minimised.

³⁵ Takano, K., Saito, Y., Kanari, K. Nozaki, K., Kato, K., Negishi, A., Kato, T. Entropy change in lithium ion cells on charge and discharge, *Journal of Applied Electrochemistry*, **32**, 251–258, 2002.

³⁶ Reynier, Y., Yazami, R., Fultz, B. The entropy and enthalpy of lithium intercalation into graphite, *Journal of Power Sources*, **119–121**, 850–855, 2003.

3.1.3 Experimental

A commercial battery module was characterised using the developed semi-empirical methodology³², and the resulting battery model was validated experimentally with a real-world duty cycle. The characterisation of the capacity, open-circuit voltage, internal impedance, entropy change, and thermal properties of commercial battery modules was performed by using only two types of experiments: (i) galvanostatic intermittent discharging and charging and (ii) continuous thermal loading. Module-level characterisation inherently includes the manufacturing tolerances between the cells in a module as well as the effects of the cooling system into the model. Furthermore, it results in a low-order model that can be scaled for any battery pack configuration.

3.1.3.1 Modelling

The model consists of coupled lumped-parameter electrical and thermal models, which are shown in **Figure 23**, where i_b is the battery current, u_b is the battery voltage, u_{oc} is the OCV, s_Q is the SOC, T is the temperature, P_{gh} is the generated heat, P_d is the dissipated heat, resistances and capacitances are the impedance parameters or thermal impedance parameters, and $u_1 \dots u_n$ and $\theta_1 \dots \theta_n$ are the corresponding voltages or temperature rises. The model needs current and ambient temperature as input data and predicts the SOC, OCV, terminal voltage, power losses, generated heat, dissipated heat, and temperature. The coupling between the models is twofold: the temperature affects the parameters of the electrical model, and the electrical model is used to predict the generated heat, as follows:

$$P_{gh} = (u_{oc} - u_b)i_b + i_b T \frac{\Delta S}{n_e F}, \quad (1)$$

where T is the temperature, ΔS is the entropy change, n_e is the number of electrons ($n_e = 1$ for Li-ion batteries), and F is the Faraday constant (96 500 C mol⁻¹).

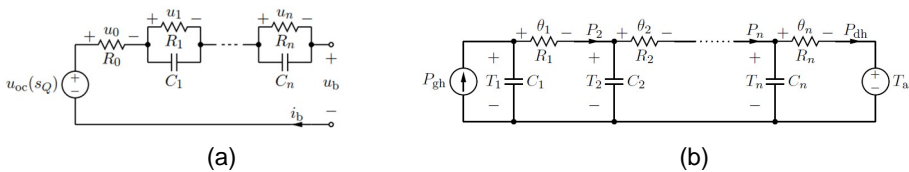

Figure 23. Lumped-parameter equivalent circuits models. (a) Electrical model. (b) Thermal model.

3.1.3.2 Experimental setup

A commercial battery module from Kokam was used in the experiments. The module consisted of seven series-connected Kokam SLPB 100216216H cells, which were 40-Ah cells with pouch-type construction and tabs on one side. The positive

electrode material was LiNiMnCoO_2 and the negative electrode material was graphite. The battery module included all internal connections, cell voltage measurement for each cell, and four temperature measurements, from which three were located between every other cell and one was located on top of the top cell. The temperature sensors were mounted close to the positive tab of a cell. There was no cooling in the module. The cells were stacked together and the stack was circumligated with adhesive tape. A BMS by Reap Systems was used.

All the tests were conducted inside a thermal chamber from Arctest. A water-cooled dc electronic load, model PLW36K-120-1500 from Amrel, which had maximum current, voltage, and power ratings of 1500 A, 120 V, and 36 kW, respectively, was used to discharge the battery. Two parallel-connected Powerfinn PAP3200 power supplies with a 3.2-kW power rating were used to charge the battery. Each power supply had an output voltage range of 0–36 V and a current range of 0–127 A. Hence, the total maximum current and power ratings were 254 A and 6.4 kW, respectively. A Hioki 3390 power analyser with a Hioki 9279 current clamp was used to measure the current, voltage, power, and ampere-hours.

3.1.3.3 Characterisation experiments

The thermal resistivity and heat capacity of the battery module are extracted from a thermal characterisation test (TCT), and the capacity, OCV, internal impedance characteristics, and entropy change are extracted from an electrical characterisation test (ECT). The TCT consists of repetitive discharge and charge pulses within a small SOC range to provide continuous thermal loading for the battery, while the ECT consists of galvanostatic intermittent discharging and charging experiments. Because the internal impedance is dependent on the rate and temperature, the ECT needs to be performed at several rates and temperatures to achieve good accuracy throughout the whole anticipated operating area. The ECT and TCT are illustrated in **Figure 24** and **Figure 25**, respectively.

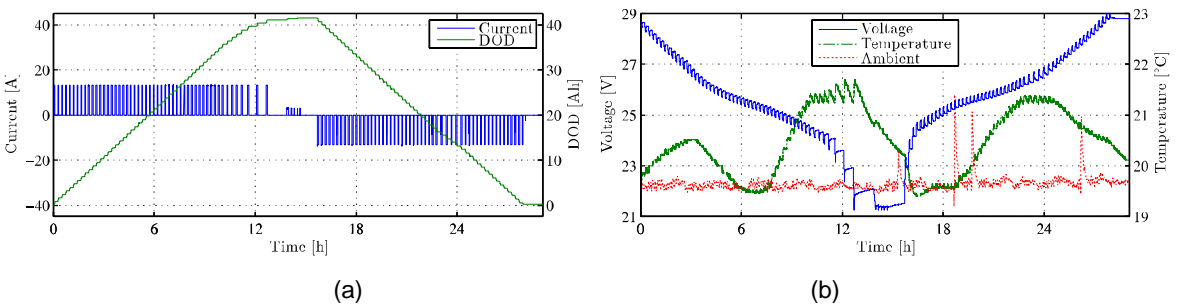

Figure 24. Electrical characterisation test at 20 °C temperature and a C/3 rate. (a) Current and depth of discharge (DOD). (b) Voltage, temperature, and ambient temperature.

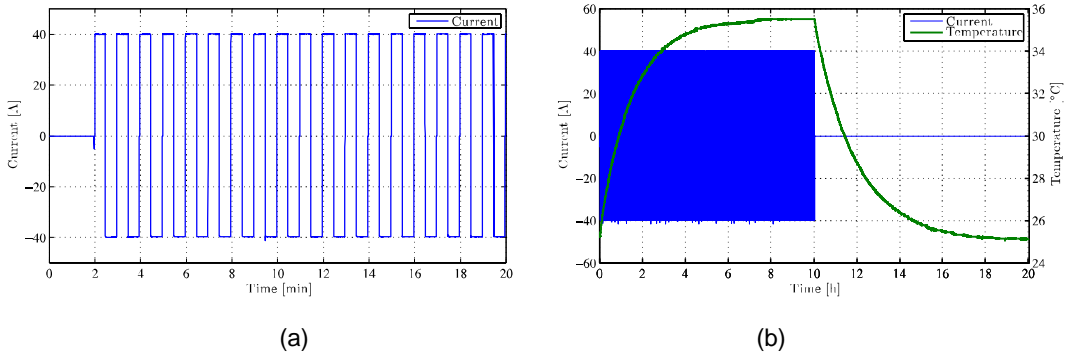

Figure 25. Thermal characterisation test. (a) Current waveform. (b) Current and temperature during the test.

A TCT was performed at ambient temperatures of 25 °C and 10 °C to reveal the possible temperature dependency. At 25 °C, the test was performed with a 1C rate to achieve a temperature rise of at least a few degrees but less than 15 °C. At an ambient temperature of 10 °C, at which the losses were presumed to be higher, the test was conducted at a C/2 rate to achieve a low temperature rise.

ECTs were conducted at temperature steps of 5 °C within the allowed temperature range of the battery, i.e., 10–45 °C. However, because the actual temperature during a test is higher than the ambient temperature and because the BMS was configured to limit the charge current at 45 °C, the maximum characterised temperature setpoint was selected to be 40 °C. The experiments were performed at rates of C/3, 1C, and 3C for charging and C/3, 1C, 3C, and 6C for discharging to characterise the rate effect in impedance. Each experiment was performed with a 2% pulse ratio and a 10-min minimum rest period. The temperature threshold was typically approximately 1.75 °C above the ambient temperature, ranging from 1 °C to 2.5 °C because of differences in the setpoints.

3.1.3.4 Validation experiments

A real-world duty cycle³⁷ of an underground mining load-haul-dump (LHD) loader was used as the main validation cycle. The cycle is a charge depleting (CD) cycle with a duration of 416 s. A charge depleting minimum PHEV cycle³⁸ was used as another validation power profile. The cycle is a CD cycle with a duration of 360 s.

³⁷ Hentunen, A., Kukkonen, S., Lehmuspelto, T., Pihlatie, M. Development and validation of a Li-ion battery pack for non-road mobile machinery applications, in Proc. Electric Vehicle Symposium (EVS27), Barcelona, Spain, 2013.

³⁸ Battery Test Manual for Plug-In Hybrid Electric Vehicles, 2nd ed., U.S. Department of Energy, Vehicle Technology Program, INL/EXT-07-12536, Dec. 2010.

3.1.4 Results

The thermal model and the electrical model were parameterised based on the characterisation experiments. **Figure 26** presents the measured end-of-test capacities and the extracted maximum usable charge capacities. No significant temperature effect in the usable capacity was observed. The reason for the reduced capacity at higher rates, especially at colder temperatures, can be attributed to the voltage drop caused by the internal impedance and the applied current.

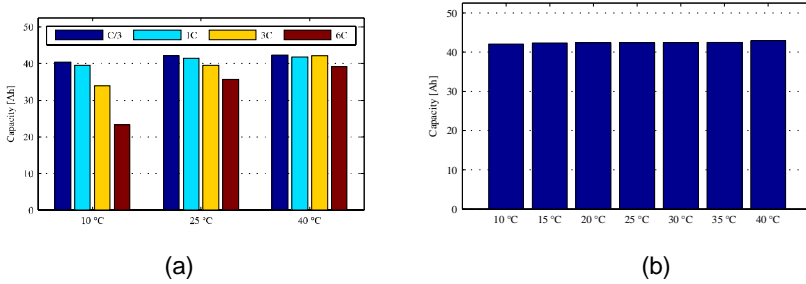

Figure 26. Extraction of the capacity. (a) Measured end-of-test capacity. (b) Extracted usable capacity.

In **Figure 27**, the maximum absolute percentage error (APE) and root mean square percentage error (RMSPE) for pulse discharge (PD) test at 1C, PHEV test, and LHD test are compared for model orders between 1–5. The accuracy was improved consistently with the increase of the order of the model. The order of the model can be selected on the basis of the accuracy requirements and the allowable computational burden. Based on the results, a fifth-order model was selected and is used in the rest of this paper.

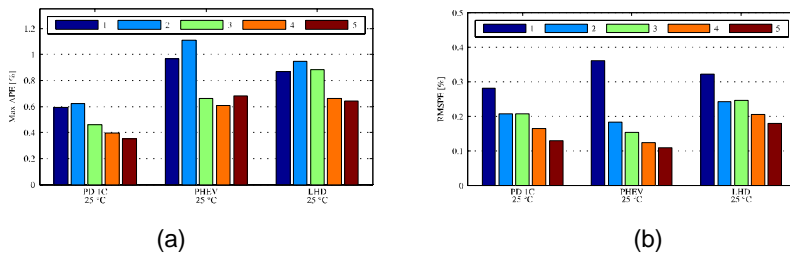

Figure 27. Voltage error measures as model order is varied. SOC range: 10–90%. (a) Max APE. (b) RMSPE.

The extracted OCV, ohmic resistance, and entropy change characteristics are shown in **Figure 28**. The OCV did not show significant temperature dependency.

However, the temperature had a large impact on the ohmic resistance: the resistance at 10 °C showed a more than 100% increase compared to the resistance at 40 °C. During discharging, the reversible heat generation is endothermic between 30–70% SoC and exothermic for a SoC higher than 70% or lower than 30%. During charging, the effects are reversed, i.e., reversible heat generation is exothermic for 30–70% SoC and endothermic for a SoC higher than 70% or lower than 30%.

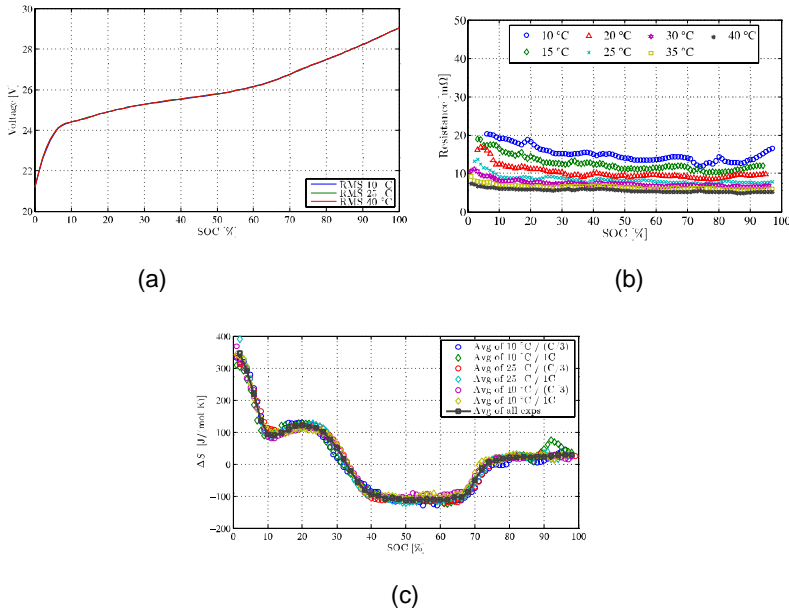

Figure 28. Extracted parameter maps. (a) Open-circuit voltage. (b) Ohmic resistance for discharge at a 1C rate. (c) Entropy change characteristics.

The results of an LHD test at 25 °C at around a 46% SoC and a 22% SoC are shown in **Figure 29**. The heat generation changes remarkably during the test. At 46% SoC, which is shown in **Figure 29(a)**, the heat generation is high during the regeneration phase of the cycle, i.e., during charging, and low during discharging. As expected, the measured and simulated temperatures rise during the high peaks in the generated heat and stay almost constant during other phases of the cycle as the dissipated heat has a similar magnitude to the generated heat. At 22% SoC, which is shown in **Figure 29(b)**, the generated heat during the cycle has a totally different shape. Now the generated heat is low during the regeneration and high during discharge phases with high current. Consequently, the measured and simulated temperatures rise during the discharge phase and stay almost constant or fade slowly during other phases. The resistance values at 46% and 22% SoC have only minor differences. The reason for the differences in the heat generation can be found from the entropy change characteristics, which are shown in **Figure 28(c)**. The entropy change has approximate values of $-110 \text{ Jmol}^{-1}\text{K}^{-1}$ and $120 \text{ Jmol}^{-1}\text{K}^{-1}$ at the SoC of

46% and 22%, respectively. Therefore, the magnitude of the entropic heat generation is almost the same, but the polarity is reversed, which explains the different behaviour in the heat generation.

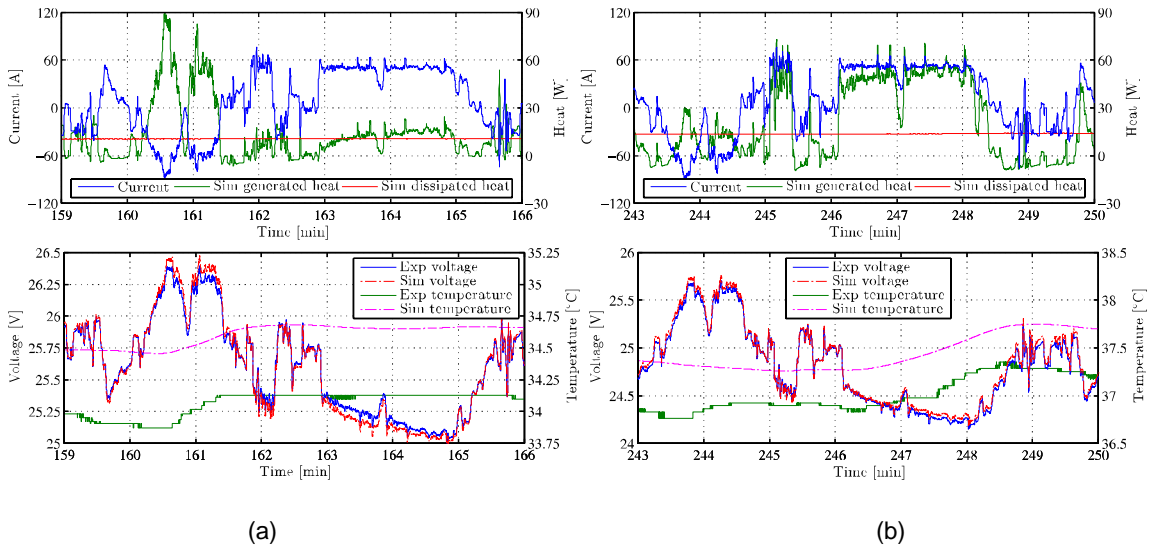

Figure 29. Results of an LHD test at 25 °C temperature at around 46% SOC in (a) and around 22% SOC in (b).

3.1.5 Discussion

Non-road mobile machinery manufacturers often use commercial battery modules as basic building blocks for battery pack development. Therefore, they need tools for performance assessment and the characterisation of the electrical and thermal properties of battery modules and packs. The adoption of a model-based approach for the development of battery systems saves time, effort, and cost involved in experimental testing. With the model-based approach, once a battery module is characterised and validated, the effect of different battery configurations, ambient temperature conditions, and aging can be evaluated easily by means of computer simulations. Furthermore, the performance of an existing battery pack can be assessed accurately and rapidly for new duty cycles and operating conditions.

3.1.6 Conclusions

In this research, efficient and effective methods for the electrical and thermal characterisation of Li-ion batteries were developed to minimise the time and effort involved in experimental testing and parameterisation, as well as to improve the accuracy of the resulting model. This paper demonstrated the use of the methods and

discussed the advantages and opportunities of using such methods for the development of battery systems for ECVs and NRMM. A semi-empirical approach, in which the battery model consists of coupled lumped-parameter electrical and thermal models and the characterisation is performed on the basis of current, voltage, and temperature data, was adopted. The battery can be regarded as a black box, and therefore, no proprietary information nor any details of the inner construction of a battery cell, module, or pack are needed. The experiments can be performed with a battery cyler and a thermal chamber, and the characterisation can be performed directly for cells, modules, and packs. The order of the model can be selected to comply with the accuracy requirements and the allowable computational burden.

3.1.7 Acknowledgements

This study was carried in the ECV project funded by the Finnish Funding Agency for Technology and Innovation (Tekes).

3.2 Research highlights from experimental battery research

Authors: Ville Erkkilä

Affiliations: VTT Technical Research Centre of Finland Ltd

Contact information for main author: ville.erkkila@vtt.fi

Abstract

At the VTT battery laboratory, a large battery database of commercial battery cells was established during the ECV-eStorage3 project. Our experimental methodology has been developed to comprehensively characterise battery cells in a short period of time. The performance of different Li-ion battery chemistries was seen to vary and performance differences were found also between the same Li-ion chemistries from different manufacturers. Also, lifetime testing was carried out and results show the excellent cycle lifetime of battery cells with a lithium titanate (LTO) anode. The ECV project has enabled VTT to develop methods and tools to design and dimension battery systems.

3.2.1 Introduction

To reduce the dependency on fossil fuels and the amount of CO₂ and other emissions, alternative sources of energy are needed for various heavy-duty commercial vehicles. Batteries and high-power charging systems can provide a solution to electrify many commercial vehicles like city buses. Some types of these plug-in or fully electric commercial vehicles can already be economically feasible³⁹. Electrification of commercial vehicles can open new possibilities. For example, due to the reduced

³⁹ Pihlatie, M., Kukkonen, S., Halmeaho, T., Karvonen, V., Nylund, N.-O. Fully Electric City Buses – The Viable Option, Electric Vehicle Conference (IEVC), 2014 IEEE International, DOI:10.1109/IEVC.2014.7056145.

noise, night time operation in city centres becomes possible. In mines, electric vehicles produce less heat and emissions, and ventilation can be reduced.

3.2.2 Experimental

Currently, many kinds of batteries are produced with variable quality. Due to the challenging operation patterns in heavy-duty commercial vehicles, special care needs to be paid to the selection of appropriate batteries for each application. Therefore, we have developed comprehensive characterisation methods for battery cells, where the most important parameters can be extracted in few days. Based on this data and the required operation patterns, we are able to recommend suitable batteries for a given application.

Battery characterisation tests include pre-conditioning, capacity, dynamic, and pulse tests and also electrochemical impedance spectroscopy (EIS). The pre-conditioning test comprises three consecutive C/3 charge and discharge cycles and is performed to verify the integrity of the cell. The C-rate is the normalised current relative to the cell capacity. 1C means the current when the cell is fully charged to 100% state of charge (SoC) in one hour.

The capacity test measures the available capacity of the cell with various charge and discharge currents. Here, C/3, 1C, 2C, and maximum current charge and discharge cycles are performed. Also, energy content, temperature behaviour, and coulombic and energy efficiency can be calculated from this test.

The dynamic performance test is done according to the IEC 61982-2 standard, where a one-minute cycle is used to simulate normal driving. First, the cell is charged with a C/3 rate. The cycle starts with a 10-second 1.6C discharge, followed by 20-second 0.4C discharge. Then, a 5-second 0.8C charge is performed and the cycle ends with a 25-second rest. This cycle is repeated until the minimum voltage is reached. After that, the cell is charged with 1C and the cycle is repeated three times altogether. This test allows us to calculate the specific energy and the energy density of the battery cell.

The pulse test comprises equal charge and discharge pulses of a 10-second duration. Here, charge and discharge pulses are C/3, 1C, 2C, 5C, and maximum current. This pulse train is performed at 80%, 65%, 50%, 35%, and 20% states of charge. From this test, we can calculate the pulse energy efficiency, power densities, and the pulse resistances.

The EIS is done in a galvanostatic mode with a suitable ac signal and 0 A_{dc} offset from 5 kHz to 0.1 Hz. The measurement is made at 100%, 80%, 50%, 20% and 0% states of charge. The EIS shows the frequency behaviour of the cell and we can use it to analyse the electrochemical properties of the battery cell.

Additionally, these characterisation tests can also be performed in a controlled environmental chamber, where the performance of a cell can be tested in different temperatures. In all tests, we follow the specifications given by the manufacturer. In this way, we can compare our results with datasheet values.

For electrical cell tests, we use a PEC SBT0550 tester, which has 24 channels up to 5 volts of which a maximum of 12 channels can be connected in parallel to

obtain maximum current of 600 amperes, and maximum power of 3 kilowatts. For the EIS measurements, the laboratory has Gamry Reference 3000 with Reference 30K Booster. This equipment can produce a voltage up to 32 volts, and current up to 30 amperes with a frequency bandwidth of 300 kHz. For environmental testing, a Vötsch VT 4011 temperature test cabinet was used. It has volume of 110 litres and the temperature range is from $-40\text{ }^{\circ}\text{C}$ to $180\text{ }^{\circ}\text{C}$.

Characterisation data can also be used to extract parameters for an electrical battery model. This model can be used to simulate known operation patterns to verify the electrical performance of the chosen battery design. The electrical equivalent circuit model is a Thévenin-based model from Chen and Rincón-Mora⁴⁰, which is commonly used to model Li-ion batteries. On the system level, time domain parametrisation offers many benefits compared to frequency domain-based impedance methods. Our goal has been to develop a very fast parametrisation method with acceptable accuracy. The time domain parameter extraction method is based on the work of Ari Hentunen⁴¹. The model comprises a series resistor with two RC circuits and is implemented in MATLAB Simulink. Here, the series resistance is calculated from the instantaneous voltage difference during the beginning of a current pulse, and the RC circuit parameters are extracted from the characteristics of the voltage relaxation. This method was further developed so that the required parameters can be calculated from characterisation pulse test data. This way the electrical parametrisation can be done in one working day with acceptable model accuracy. From 100% to 20% SoC the accuracy remains around 2%, but below 20% SoC it drops significantly. However, this drop in accuracy is usually acceptable as vehicles operate in the middle of the SoC curve. Normally, the electrical model represents one battery cell. The electric model is validated with a dynamic discharge test. In addition, the electrical model can give power losses as an output to a thermal model implemented in COMSOL Multiphysics. With this thermal model, we can evaluate what kind of cooling system is required by certain operation patterns. We can also compare different cooling methods and materials to find the optimal solution.

3.2.3 Results

So far, we have characterised close to 150 battery cells from 11 different manufacturers. These test results are collected in the battery database, which can be used for choosing the right type of battery for a certain application. This database allows to compare the performance of different chemistries and also the performance and quality of similar chemistries between different manufacturers. Also, at least five cells of each type have been tested enabling estimation of the manufacturing quality and study cell homogeneity.

⁴⁰ Chen, M., Member, S., Rinc, G.A. Accurate Electrical Battery Model Capable of Predicting Runtime and I – V Performance. *IEEE Trans. Energy Convers.*, **21**(2), 504–511, 2006.

⁴¹ Hentunen, A., Lehmuspelto, T., Suomela, J. Time-Domain Parameter Extraction Method for Thévenin-Equivalent Circuit Battery Models. *IEEE Trans. Energy Convers.*, **29**(3), 558–566, 2014.

With regard to the quality of the cell manufacturing, the homogeneity of the cell capacity is one criterion for comparison. **Table 1** presents the differences between the discharge capacities of the graphite/LiFePO₄ (G/LFP) cells we have tested.

Table 1. Quality differences between tested G/LFP cells.

Chemistry	Number of tested cells	Standard deviation, C/3 discharge capacity [%]	Standard deviation, 2C discharge capacity [%]
G/LFP	5	0.32	0.74
G/LFP	20	0.48	0.96
G/LFP	20	0.48	1.66
G/LFP	4	2.11	2.29
G/LFP	10	1.00	5.70

From the table we can see that the difference between the most homogenous and the least homogenous cells is significant. All of the cells are of the same chemistry, but from different manufacturers. The homogeneity of the capacities is important when the cells are packaged into battery packs where differences in cell capacity lead to more time-consuming cell balancing during charge.

Figure 30 presents the charge capability comparison between different cell chemistries. This shows how fast a certain cell can be charged and how close to full charge it gets with a constant current. This is usually one of the most important performance parameters when designing a battery where fast charging is required. On the x-axis we have the C-rate and on the y-axis the charge capacity in per cents, meaning the amount of Ah that the cell takes in with certain constant current before reaching the upper voltage limit. Cells A and B present the charge capability of batteries with a graphite anode and LFP cathode. Cell A is the best-performing cell and cell B is the worst cell in terms of charge capability. It can be clearly seen that the difference between the best and the worst cell is very significant.

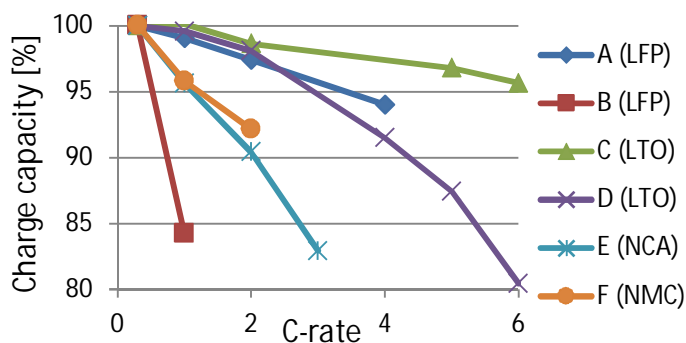

Figure 30. Charge capability comparison between different cell chemistries.

Cells C and D show the charge capability of the $\text{Li}_4\text{Ti}_5\text{O}_{12}/\text{LiNi}_x\text{Mn}_y\text{Co}_z\text{O}_2$ (LTO/NMC) chemistry. Again, C is the best and D is the worst cell. Here, the difference between the two is smaller and both perform quite well. Cell E is of the graphite/ $\text{LiNi}_x\text{Co}_y\text{Al}_z\text{O}_2$ (G/NCA) chemistry and cell F of the graphite/ $\text{LiNi}_x\text{Mn}_y\text{Co}_z\text{O}_2$ (G/NMC) chemistry. Their charge performance is slightly better than that of the worst LFP cell.

Figure 31 shows the same cells compared based on their energy efficiency and specific energy.

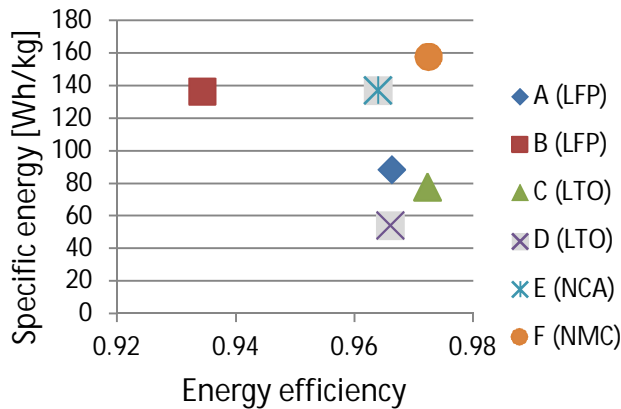

Figure 31. Energy efficiency and specific energy comparison between different cell chemistries.

On the x-axis, we have the energy efficiency of the cell based on a C/3 constant current charge and discharge capacity test. On the y-axis, we have the specific energy of the cell measured with the dynamic discharge test where the average discharge rate is C/3. **Figure 31** explains the notable differences in charge capability presented in **Figure 30**. Battery cells can be optimised for different purposes: power-optimised cells perform well with high currents, and energy-optimised cells have more energy per weight. The optimisation is done by altering the thickness of the electrode sheets. Thin electrodes are able to move ions quickly and are suitable for high power applications. With thicker electrodes, more energy can be stored but the speed at which the ions move is slower. These cells are more suitable for applications where energy content is more important than high power capability. **Figure 31** shows the difference between these two types of cells. Here, power-optimised cells have a specific energy under 90 Wh/kg, whereas energy optimised cells have specific energy over 130 Wh/kg. The difference between the highest and the lowest specific energies is almost threefold.

As these properties depend on the physical cell design, a cell with both high power capability and high specific energy cannot be produced with current Li-ion

technology. Therefore, the design and dimensioning of a battery pack must be based on the requirements of the chosen application.

Cycle life testing of batteries is time-consuming research and usually some kind of acceleration factor is used instead of testing the batteries with exact real life cycles. The acceleration factors most often used are wide SoC range, increased temperature, or small capacity of cells. No studies in the scientific literature present results from cycle life tests done with narrow SoC range at room temperature with large format cells. Our research has studied the effect the SoC range has on aging. **Figure 32** presents the results of a cycle life test for G/LFP cells with 1C charge and 2C discharge in three SoC windows: 100–0%, 80–0%, and 100–20%.

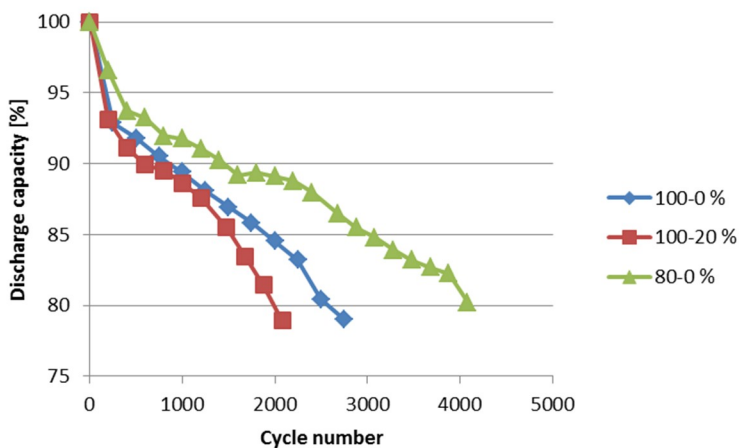

Figure 32. Cycle life testing for G/LFP cells with three SoC windows.

In the figure above, it is clearly seen that the effect of the SoC range on the lifetime is not simple. One would assume the narrower SoC range to have a beneficial impact on cycle life but clearly, for the cell studied, the 100–20% range is much more harmful for the cell than 80–0% range. However, this study indicates that the more important factor is the average SoC during the lifetime. In **Figure 32**, the cell with the shortest cycle life has the highest average SoC of 60%, whereas the cell with the longest cycle life has the lowest average SoC of 40%.

Figure 33 shows the same cycle life test but done with LTO/NMC cells.

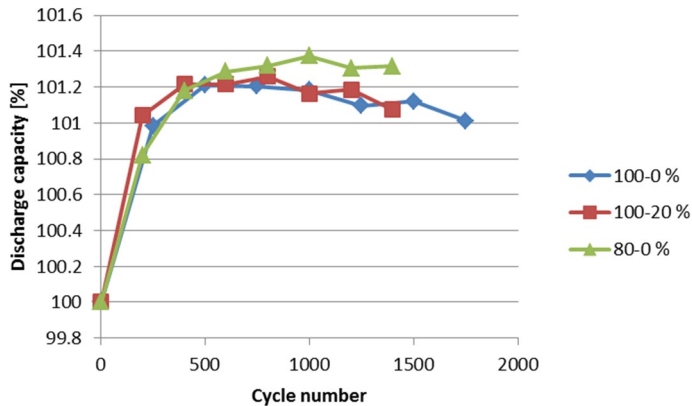

Figure 33. Cycle life testing for LTO/NMC cells with three SoC windows.

After 1500 cycles of testing, the cell performance was still better than initially. Therefore, the testing was not continued further. LTO/NMC cells withstand much higher currents and testing them with similar currents to G/LFP cells was not representative. However, the test still managed to illustrate the superior cycle life performance of the LTO versus graphite anode.

The developed electrical model enables us to verify dimensioning of a battery over its lifetime. In **Figure 34** the power loss of a battery versus its lifetime is shown.

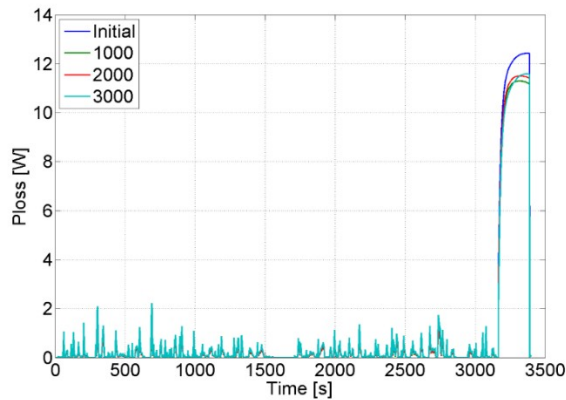

Figure 34. Power loss of a battery over its lifetime.

By using the characterisation and lifetime test data, we can evaluate the performance of the battery over its lifetime. In the case of **Figure 34**, it was used to verify the dimensioning of a thermal management system. From the figure, you can see that in this case the power losses do not increase over the battery's lifetime and

there is no need to over dimension the thermal management system. This way, the model can also be used to verify the electrical performance of the cell. For example, for how long the battery will maintain its power capability.⁴²

3.2.4 Discussion

With experimental testing, we have found that the quality of the battery cells varies. The cheaper cells are usually of lower quality while more expensive cells are of better quality. Here, quality refers especially to the homogeneity of the cells from the same manufacturing lot. The homogeneity of the cells is important when hundreds of cells are assembled into a battery pack because the performance of the battery pack is limited by the performance of the worst cell.

Testing has also revealed big differences in performance between different Li-ion battery chemistries as well as performance differences between cells of the same chemistry but from different manufacturers. Although LFP batteries are often cheaper and safer, they do not perform as well as lithium nickel oxide batteries (NMC/NCA). In lifetime testing, cells with a LTO anode have proven their superiority over graphite anode cells. Furthermore, with G/LFP cells the lifetime is maximised by having a low average SoC during cycling. However, to understand the degradation mechanisms better we need further research.

Battery technology is developing constantly and we need continuous testing to keep up to date with the state-of-the-art. The work done during this project has created methods and tools necessary for designing suitable and safe batteries for electric commercial vehicles.

3.2.5 Conclusions

The methods, data, and tools that have been developed in VTT battery research can be used to select the appropriate cell chemistry and type, dimensioning and design of the battery pack, and dimensioning of the cooling/heating system for the battery pack. Modelling and simulation results depend on how accurately the real operation pattern of an application is known. The tools will be of great aid in the product development of electric vehicles and energy storages.

3.2.6 Acknowledgements

This study was carried in the ECV project funded by the Finnish Funding Agency for Technology and Innovation (Tekes).

⁴² Kukkonen, S., Erkkilä, V., Manninen, A., Haavisto, J., Pihlatie, M. Method for Dimensioning Battery and Thermal Management Systems for Heavy-Duty Vehicle Applications Using Aged Battery Experimental Data and Advanced Modelling Techniques. ECS Transactions, **68**(2), 83–95, 2015.

3.3 Aging of commercial NMC/graphite Li-ion cells at elevated temperatures

Authors: Kirsi Jalkanen^a, Juha Karppinen^b, Lasse Skogström^b, Tomi Laurila^b, Mikko Nisula^a, Kai Vuorilehto^a

Affiliations: ^aDepartment of Chemistry, School of Chemical Technology, Aalto University; ^bDepartment of Electrical Engineering and Automation, School of Electrical Engineering, Aalto University

Contact information for main author: kirsi.jalkanen@iki.fi

Abstract

The aging of commercial, pouch-type Li(Ni,Mn,Co)O₂/graphite Li-ion cells was studied at different cycling temperature conditions: room temperature, +45 °C charge/discharge, and +45 °C charge/+65 °C discharge. Impedance spectra were recorded at intervals of 100 cycles. The cell cycle life was found to reduce notably when cycling was performed at higher temperatures, due to the accelerated capacity decrease. After 80%/50% capacity fade, the cells were disassembled and a post-mortem analysis was performed. A very significant amount of plated lithium was found on the graphite negative electrodes of the cell cycled at +45 °C charge/+65 °C discharge, which was concluded as a major reason for the observed capacity fade. In addition, the impedance behaviour was distinctly different for the +45 °C/+65 °C cycled cell, showing accelerated growth of both ohmic and polarisation resistances, in comparison to the other cells. The high ohmic resistance was attributed to an increased separator resistance, due to adhered depositions, and to lack of electrolyte. On the other hand, increased charge transfer resistances, a thick and more resistive passivation layer on the graphite electrode and mechanical coating cracking at the Li(Ni,Mn,Co)O₂ electrode were possible factors resulting in the increased polarisation resistance. In conclusion, post-mortem analysis is an essential tool for determining the mechanisms leading to a cell's end of life.

3.3.1 Introduction

Especially in large-scale battery packs, the absolute safety and long lifetime of battery cells are crucial. For example, the energy stored in the battery pack of an electric vehicle (EV) can range from 20 kWh up to even 100 kWh. If such a large amount of energy is released in an uncontrollable way, the consequences are serious. Furthermore, a lifetime of 15 years including at least 1 000 charge-discharge cycles has been set as a goal for EV batteries.⁴³ In order to meet these demands, the cell aging is to be studied at different conditions. Cell disassembly and post-mortem

⁴³ U.S. Department of Energy, Energy Efficiency & Renewable Energy, FY 2014 Annual Progress Report – Energy Storage R&D, 2015, pp. 11–12. Available at http://energy.gov/sites/prod/files/2015/03/f20/FY2014_APR_Energy_Storage_R%26D_FI-NAL_Part1_of_3_0.pdf (accessed 11.8.2015).

analysis are important tools for characterising the mechanisms behind the observed aging and for tracking down possible safety risks.

Li-ion cell aging is observed as capacity fade and resistance increase, leading to decreased energy density. The aging rate is typically dependent on the cycling or storage conditions: temperature, current rate, and state of charge, for example. Aging can originate from both chemical and mechanical factors, and it can take place in the active electrode materials as well as in the inactive components, like in the current collectors, binder materials, or conductive agents. The chemical aging factors comprise reactions at the electrode/electrolyte interfaces, structural changes, and loss of active material due to dissolution.⁴⁴ In addition, volume changes in the active materials, current collector corrosion, and degradation of binder materials or conductive agents can lead to contact losses and thus to loss of active electrode materials.⁴⁵

In general, cell aging is mostly affected by the choice of electrode materials, and particularly it is often related to the graphite negative electrode. For cells containing a graphite negative electrode, the typical aging mechanism is the decomposition and reformation of a passivating Solid Electrolyte Interface layer (SEI) at the graphite surface, which is accelerated at elevated temperatures.⁴⁶ In the SEI-layer formation reactions, active lithium (that is, cell capacity) and electrolyte are consumed, and the layer growth also increases the graphite electrode resistance.

Another graphite electrode-related aging mechanism is the plating of lithium as metallic on the graphite surface during cell charging, instead of intercalating into the graphite lattice. This lithium plating phenomenon is promoted by low temperatures and high charging currents, whereby the graphite electrode can reach potentials below 0 V vs. Li/Li⁺ due to high polarisation or mass transport limitation.⁴⁷ The lithium deposition has the tendency to grow as dendrites, which can further propose a severe safety risk if they penetrate the separator to the positive electrode, thus causing an internal short circuit in the cell. Furthermore, active lithium is lost and electrolyte consumed due to lithium plating formation.

In this study, the aging of commercial Li-ion cells consisting of Li(Ni,Mn,Co)O₂ (NMC) positive and graphite negative electrodes was studied at different elevated

⁴⁴ Vetter, J. et al. *J. Power Sources*, **147**, 269–281, 2005; Sarre, G. et al. *J. Power Sources*, **127**, 65–71, 2004; Wohlfahrt-Mehrens, M. et al. *J. Power Sources*, **127**, 58–64, 2004.

⁴⁵ Vetter, J. et al. *J. Power Sources*, **147**, 269–281, 2005; Arora, P. et al. *J. Electrochem. Soc.*, **145**, 3647–3667, 1998; Broussely, M. et al. *J. Power Sources*, **146**, 90–96, 2005; Li, Y. et al. *J. Electrochem. Soc.*, **160**, A3006–A3019, 2013; Yoon, T. et al. *J. Power Sources*, **215**, 312–316, 2012.

⁴⁶ Sarre, G. et al. *J. Power Sources*, **127**, 65–71, 2004; Broussely, M. et al. *J. Power Sources*, **146**, 90–96, 2005; Spotnitz, R. et al. *J. Power Sources*, **113**, 72–80, 2003; Ploehn, H.J. et al. *J. Electrochem. Soc.*, **151**, A456–A462, 2004; Aurbach, D. *J. Power Sources*, **89**, 206–218, 2000.

⁴⁷ Vetter, J. et al. *J. Power Sources*, **147**, 269–281, 2005; Arora, P. et al. *J. Electrochem. Soc.*, **145**, 3647–3667, 1998; Arora, P. et al. *J. Electrochem. Soc.*, **146**, 3543–3553, 1999; Zhang, S.S. et al. *J. Power Sources*, **160**, 1349–1354, 2006; Petzl, M. et al. *J. Power Sources*, **275**, 799–807, 2015; Petzl, M. et al. *J. Power Sources*, **254**, 80–87, 2014; Legrand, N. et al. *J. Power Sources*, **245**, 208–216, 2014; Li, Z. et al. *J. Power Sources*, **254**, 168–182, 2014; Smart, M.C. et al. *J. Electrochem. Soc.*, **158**, A379–A389, 2011.

temperature conditions. The +45 °C charge/+65 °C discharge was observed to not only decrease the cycle life but also introduce a safety risk due to a drastically increased amount of lithium plating, although the cycling was performed at elevated temperatures.

3.3.2 Experimental

Commercial, pouch-type NMC/graphite cells with 40 Ah nominal capacity⁴⁸ were cycled at 1C current rate at different temperature conditions: room temperature, +45 °C charge/discharge, and +45 °C charge/+65 °C discharge. After every 100 cycles, the cycling was interrupted and the cells were characterised with electrochemical impedance spectroscopy (EIS). The cells cycled at room temperature and at +45 °C charge/discharge were disassembled after the capacity had dropped to approx. 80% of the nominal. For the +45 °C charge/+65 °C discharge cell, the cycling was performed until approx. 50% capacity fade, in order to emphasise the effects of extreme temperature conditions by the prolonged cycling. After the cells had reached the 80%/50% condition, they were disassembled at 30% state of charge (SoC). A fresh, non-cycled cell was disassembled as a reference. The cells were studied visually, and samples were taken from the electrodes and analysed with X-ray diffraction (XRD), scanning electron microscopy (SEM), energy dispersive X-ray spectroscopy (EDS), and inductively coupled plasma optical emission spectroscopy (ICP-OES). Specific experimental details are presented in the original research article.⁴⁹ More information on interpreting cell disassembly and post-mortem analysis results can be found in the literature (Chapter 2.2 and references therein).⁵⁰

3.3.3 Results

The capacity fade versus cycle number and the ohmic and polarisation resistances were tracked throughout the cells' cycle life. The ohmic resistance was defined as the high-frequency intercept of the impedance spectrum with the $\text{Re}(Z)$ axis. Polarisation resistance represents the overall electrodes' resistance, and was taken from the total spectrum width at the $\text{Re}(Z)$ axis.

The capacity of the +45 °C charge/+65 °C discharge cycled cell dropped to 80% of the nominal already after approx. 800 cycles and further to 50% after approx. 1500 cycles, whereas for the room temperature and +45 °C charge/discharge cycled cells, capacity fade to 80% was observed only after 2600 and 2000 cycles, respectively. When compared to the room temperature cell, the ohmic resistance was demonstrated to increase somewhat faster for the +45 °C charge/discharge cell, especially at later cycles (approx. 1500 cycles and after), but both the cells showed very similar polarisation resistance growth. As for the +45 °C charge/+65 °C

⁴⁸ More detailed information on the cell can be found in: Abdul-Quadir, Y. et al. *Int. J. Energy Res.*, **38**, 1424–1437, 2014.

⁴⁹ Jalkanen, K. et al. *Appl. Energy*, **154**, 160–172, 2015.

⁵⁰ Jalkanen, K. *Electrode Material Solutions for Large-Scale Lithium-Ion Batteries*, Ph.D. thesis, Aalto University, Helsinki, 2015, pp. 8–17.

discharge cell, both ohmic and polarisation resistances were clearly higher throughout the cycling in comparison to the room temperature and +45 °C charge/discharge cycled cells. More detailed information can be found in the original research article.⁴⁹

In the cell disassembly, significant visual differences were detected.⁴⁹ A summary of these observations is presented in **Table 2**.

Table 2. Visual inspection in the cell disassembly.

Reference	Room temperature	45 °C charge/ 45 °C discharge	45 °C charge/ 65 °C discharge
<ul style="list-style-type: none"> - Some metallic Li depositions on the graphite negative electrodes from formation - No adhered depositions in the separator - Plenty of electrolyte left in the cell 	<ul style="list-style-type: none"> - Same metallic Li depositions on the graphite electrodes as in "Reference" - Some adhered depositions in the separator - Cell almost dry - Approximate electrode thickness increase compared to Reference: 5 µm for NMC, 9 µm for graphite 	<ul style="list-style-type: none"> - Same metallic Li depositions on the graphite electrodes as in "Reference" - Some Li plating formed during cycling - Adhered depositions in the separator - Cell almost dry - Approximate electrode thickness increase compared to Reference: 5 µm for NMC, 11 µm for graphite 	<ul style="list-style-type: none"> - Partial cracking and coating peel off at the NMC positive electrodes - Same metallic Li depositions on the graphite electrodes as in "Reference" - Massive Li plating on the graphite negative electrodes during cycling, many detached metallic Li grains - Separator full of adhered Li plating - Cell completely dry - Approximate electrode thickness increase compared to Reference: 5 µm for NMC, 18 µm for graphite

According to the XRD analysis, no structural changes were observed in either of the electrode materials, graphite or NMC. For the +45 °C charge/+65 °C discharge cell, lithium fluoride (LiF) was proposed to be present in the graphite SEI-layer, based on the XRD data. According to SEM imaging, no clear morphological changes were observed, apart from a slightly blurred surface of the graphite electrodes in the +45 °C charge/+65 °C discharge cell. In the EDS or ICP-OES analyses, no signs of transition metal dissolution from the NMC positive electrode were observed. For more specific information, see the original research article.⁴⁹

3.3.4 Discussion

Based on the cell disassembly results (**Table 2** and XRD, SEM, EDS, and ICP-OES methods), the capacity fade of the room temperature and +45 °C charge/discharge cycled cells was attributed to the SEI-layer growth reactions, which most probably were slightly accelerated at the elevated +45 °C temperature condition. At +45 °C, a small amount of cycling induced lithium plating was observed, too, which can have somewhat increased the capacity degradation. The significantly accelerated capacity fade of the +45 °C charge/+65 °C discharge cell on the other hand was concluded to notably originate from the lithium plating. Additionally, the graphite electrode showed an increased thickness, and LiF was detected on its surface. Such a LiF component is typically produced at elevated temperatures when the SEI-layer undergoes compositional changes, and it is known to show a high resistance.⁵¹ Most likely, growth of a thicker SEI-layer has affected the capacity fade of the +45 °C charge/+65 °C discharge cycled cell, too.

The temperature increase from room temperature to +45 °C did not influence the polarisation resistance behaviour, but the further increase to +45 °C charge/+65 °C discharge led to a significantly accelerated polarisation resistance growth. Possible factors affecting this are increased charge transfer resistance especially at the NMC positive electrode,⁴⁹ increased SEI-layer resistance at the graphite electrode (thicker SEI-layer with resistive LiF), and also coating cracking detected at the NMC positive electrode. On the other hand, the ohmic resistance increased already at the +45 °C condition, although the increase was more pronounced for the highest cycling temperature. The observed adhesions in the separator and the lack of electrolyte are suggested to have increased the ohmic resistance.

3.3.5 Conclusions

In this study, a clearly different and accelerated capacity fade was observed for an elevated temperature (+45 °C charge/+65 °C discharge) cycling condition, when compared to cycling at room temperature or at +45 °C. Furthermore, a considerable increase in both ohmic and polarisation resistances was observed. In the cell disassembly, significant amounts of plated lithium were found in the +45 °C charge/+65 °C discharge cycled cell, responsible for a considerable part of the capacity fade and cell aging. In addition, the cell's ohmic resistance was observed to increase with increasing cycling temperature, suggesting higher resistances between the electrodes (in the region containing the separator and the electrolyte).

Typically, lithium plating takes place when charging at low temperatures or with high currents. However, lithium plating condition can also take place at elevated

⁵¹ Vetter, J. et al. *J. Power Sources*, **147**, 269–281, 2005; Markovsky, B. et al. *J. Power Sources*, **119–121**, 504–510, 2003; Broussely, M. et al. *J. Power Sources*, **97–98**, 13–21, 2001.

temperatures.⁵² At high temperatures, the SEI-layer degradation reactions are promoted and a more resistive layer is introduced on the graphite surface. This can further lead to increased graphite electrode polarisation and hence to a condition, where lithium is plated as metallic instead of the intercalation reaction. In addition, the active surface area of the graphite negative electrode might be reduced, due to possible clogging of the graphite electrode pores by the massive SEI-layer.⁵³ Also, if the lithium plating or parts of the SEI-layer are adhered to the separator, the separator pores can be blocked, thus again decreasing the active surface area at the graphite electrode. If the graphite electrode surface is partially inactive, the active parts will experience a higher current. This can result in a mass transport limitation, where the graphite surface is saturated with lithium, and lithium plating takes place instead of intercalation. Furthermore, enhanced SEI-layer growth and lithium plating reactions consume electrolyte and produce gaseous components. The lack of electrolyte and the gas between electrodes can hinder the movement of lithium and thus enhance the deposition of metallic lithium. This can be further promoted by elevated temperature, as the solubility of gases decreases.

3.3.6 Acknowledgements

The Finnish Funding Agency for Technology and Innovation (TEKES) is gratefully thanked for financially supporting this research as part of the national eStorage2 research project. The invaluable support of Mr. Panu Sainio and Mr. Ari Hentunen from Aalto University in procuring the test cells and project funding is highly appreciated. Dr. Hannu Revitzer from Aalto University is thanked for performing the ICP-OES measurements.

3.4 Ageing investigation of graphite/LiFePO₄ lithium-ion cells cycled at low temperatures

Authors: Taina Rauhala¹, Kirsi Jalkanen¹, Tavo Romann², Enn Lust², Noshin Omar³, Tanja Kallio¹

Affiliations: ¹Department of Chemistry, School of Chemical Technology, Aalto University, ²Institute of Chemistry, University of Tartu, ³MOBI Research Group, Vrije Universiteit Brussel

Contact information for main author: tanja.kallio@aalto.fi

Abstract

As lithium-ion batteries are currently used in increasingly large applications, understanding of how the battery usage conditions affect battery lifetime and safety has become essential. In this work, the ageing mechanisms of commercial cylindrical

⁵² Jalkanen, K. et al. *Appl. Energy*, **154**, 160–172, 2015; Broussely, M. et al. *J. Power Sources*, **146**, 90–96, 2005; Klett, M. et al. *J. Power Sources*, **257**, 126–137, 2014; Niehoff, P. et al. *J. Electroanal. Chem.*, **707**, 110–116, 2013.

⁵³ Broussely, M. et al. *J. Power Sources*, **146**, 90–96, 2005.

graphite/LiFePO₄ lithium-ion cells (2.3 Ah, 3.3 V) were investigated. Cells aged in different conditions were carefully disassembled and various parts of the cells were examined for signs of degradation. The studied cells had been aged at temperatures of -18 °C, 0 °C or room temperature by cycling with a load profile simulating the battery usage in a battery electric vehicle (see publication by Omar et al.⁵⁴ for more information on the ageing procedure and the lifetimes of the studied cells). After the ageing period, the batteries were disassembled inside an argon-gas filled glove box (with low water vapour and oxygen levels) and samples from different parts of the electrodes were taken. Electrochemical tests and materials characterisation methods were then used to evaluate the effects of the cycling on the properties of the electrodes disassembled from the original cells. The main cause of the cell capacity decrease observed during cell cycling was found to be unwanted side reactions occurring on the graphite negative electrode. The LiFePO₄ positive electrodes, on the contrary, showed only minimal signs of degradation at all the studied temperatures.

3.4.1 Introduction

Lithium-ion batteries have traditionally been used to power small portable devices like mobile phones, tablets and laptop computers. Currently, they are utilised in increasing amounts also in larger-scale applications, such as battery and hybrid electric vehicles, where battery safety and lifetime become more critical. An understanding of how the operating conditions of the cells affect the above properties is therefore essential. Many studies have been published where the mechanisms leading to battery performance decrease are evaluated through non-destructive methods. However, in order to truly be able to understand the ageing processes and to be able to attribute the cell performance decrease to the degradation of the various cell parts, it is usually imperative to disassemble the cells and investigate the cell components individually. In such a post-mortem analysis, the aged cells are carefully disassembled in a controlled atmosphere to prevent the air sensitive cell components from reacting with the humidity in air. Therefore, the ageing of the different cell parts can be evaluated separately from each other and the identification of the ageing processes will not be disturbed by the consequences of air exposure. Post-mortem analyses of commercial lithium-ion cells have previously been reported in the literature. However, studies done on cells cycled at low temperatures have been scarce.

The objective of this work was to study the ageing of commercial graphite/LiFePO₄ cells at low temperatures (room temperature and below) through a post-mortem analysis. The lower end of the battery operating temperature range is relevant in the Nordic countries where the ambient temperature can decrease below 0 °C, meaning that batteries utilised in outdoor applications may be exposed to

⁵⁴ Omar, N., Monem, M.A., Firouz, Y., Salminen, J., Smekens, J., Hegazy, O., Gaulous, H., Mulder, G., Van den Bossche, P., Coosemans, T., Van Mierlo, J. Lithium iron phosphate based battery – Assessment of the aging parameters and development of cycle life model, *Appl. Energy*, **113**, 1575–1585, 2014.

these temperatures. Therefore, the specific ageing phenomena occurring in these conditions should be studied in more detail.

3.4.2 Experimental

Commercial power-optimised 26650 cylindrical-format graphite/LiFePO₄ cells (2.3 Ah nominal capacity) were investigated in this paper. The cells had been cycled to end-of-life (corresponds to 80% of the initial discharge capacity of the cell being left) using a charge-depleting micro cycle which simulates the load profile in a battery electric vehicle (BEV). The highest charging current pulse applied during the micro cycle corresponded to 2C, and the highest discharge rate applied was 4C. The state-of-charge range used was 0–100% (2.0–3.6 V), and between each charge-depleting micro cycling period the cells were charged using a constant current rate of 1C followed by a constant voltage period at 3.6 V. The ageing was conducted at three different temperatures of -18 °C, 0 °C and room temperature (RT). In addition to the cycle aged cells, a non-cycled cell was disassembled as a reference. The reference cell had undergone only a small amount of cycles for characterisation purposes. More information on cycle ageing can be found in⁵⁴.

One cell aged in each condition was opened and dismantled inside an argon-filled glove box (<10 ppm O₂). For the post-mortem analysis, samples were cut out at different locations of the electrode jellyroll and rinsed in dimethyl carbonate (DMC, anhydrous, ≥99%, Sigma-Aldrich) in order to remove the electrolyte salt residues.

Rate capability tests, cyclic voltammetry and electrochemical impedance spectroscopy were utilised to evaluate the effects of the various ageing conditions on the electrochemical performance of the individual electrodes. Materials characterisation methods such as X-ray diffraction, scanning electron microscopy, energy dispersive X-ray spectroscopy, and IR and Raman spectroscopy were used to investigate the structural and morphological changes that had occurred at the electrodes.

3.4.3 Results and discussion

The cycle lives of the cells at the three different temperatures corresponded to 2600 cycles at RT, 2070 cycles at 0 °C and 195 cycles at -18 °C as described in⁵⁴.

The main cause of the capacity loss of the lithium-ion cells during the BEV cycling was observed to be unwanted side reactions occurring on the graphite negative electrodes. These processes consume electrochemically active cyclable lithium from the cells, which is observed as a decrease in cell capacity. The side reactions on the graphite electrode include surface layer growth as well as metallic lithium plating on the surface of the graphite negative electrode. Which of these processes is the main capacity loss mechanism depends on the operating temperature of the cells.

The LiFePO₄ positive electrodes showed no signs of degradation apart from a lowered utilisation due to the loss of cyclable lithium from the cells. For example, iron dissolution from the material has been reported in the literature for cells cycled

at higher temperatures, indicating the occurrence of structural damage to the material⁵⁵. However, notable iron dissolution from the positive electrode was not observed in this study, which further suggests the stability of the LiFePO₄ material in low-temperature use. For more detailed information on the results, the reader is referred to the final published version of the article⁵⁶.

The electrochemical properties, such as cell impedance and capacity, of the aged lithium-ion cells prior to disassembling were very similar for all of the cells. Therefore, the different ageing processes could not have been identified without the post-mortem analysis. For example, lithium plating, which is a significant safety hazard, could not have been discovered without dismantling the cells or predicted without knowing their thermal histories. Therefore, a post-mortem analysis is concluded to be essential in evaluating the ageing mechanisms of lithium-ion batteries and also the safety of aged cells.

The degradation mechanisms and processes identified in this work are specific to the studied cell chemistry, and thus cannot be generalised to concern other cell types and material combinations. Therefore, to obtain a better understanding of the ageing behaviour of lithium-ion batteries at low temperatures, other cell chemistries should be studied as well.

3.4.4 Conclusions

In this work, the ageing mechanisms of commercial cylindrical lithium-ion cells (2.3 Ah, 3.3 V) with a graphite/LiFePO₄ chemistry were investigated through a post-mortem analysis of aged cells. The cell ageing prior to disassembly was performed at different temperatures from room temperature to -18 °C by cycling the cells with a load profile simulating the battery behaviour in a BEV. The main cause of cell capacity decrease was observed to be unwanted side reactions occurring on the graphite negative electrode, whereas the LiFePO₄ positive electrodes showed minimal signs of degradation at all the studied temperatures.

3.4.5 Acknowledgements

This work made use of the Aalto University Nanomicroscopy Center (Aalto-NMC) premises. Dr. Hannu Revitzer is gratefully acknowledged for performing the ICP-OES measurements.

⁵⁵ Klett, M., Eriksson, R., Groot, J., Svens, P., Ciosek Högström, K., Lindström, R.W. et al. Non-uniform aging of cycled commercial LiFePO₄//graphite cylindrical cells revealed by post-mortem analysis, *J. Power Sources*, **257**, 126–137, 2014.

⁵⁶ Rauhala, T., Jalkanen, K., Romann, T., Lust, E., Omar, N., Kallio, T., Low-temperature aging mechanisms of commercial graphite/LiFePO₄ cells cycled with a simulated electric vehicle load profile—A post-mortem study, *J. Energy Storage*, **20**, 344–356, 2018.

4. Electric buses and powertrains

4.1 Electric city bus energy flow model

Authors: Teemu Halmeaho, Pekka Rahkola, Ari-Pekka Pellikka, Sami Ruotsalainen*, and Kari Tammi

Affiliations: VTT Technical Research Centre of Finland Ltd, *Helsinki Metropolia University of Applied Sciences

Contact information for main author: pekka.rahkola@vtt.fi

Abstract

A battery electric city bus model has been created and the simulation results compared against the measured results from the full-scale city bus developed for heavy vehicle research. The model utilises multi-physics modelling approach with multiple-domains from friction-tyre and transmission model to electrical drive and a simplified battery model. Simulated and measured values for motor torque, current, and voltages in the battery and inverter and the bus speed were compared under a driving cycle based on a local bus line. The simulated results were in good agreement with the experimental measured results; the error between the simulated and measured energy consumption was 1.4%. The measured average energy consumption was 0.581 kWh/km while the simulation estimated 0.589 kWh/km.

4.1.1 Introduction

A simulation tool to analyse vehicle energy consumption is presented. The model of an electric bus and the model validation by measurements on the electric bus prototype are shown. Although several simulation tools have already been presented, the authors believe the depth of modelling details and the validation constitutes a major scientific contribution of this paper.

The current boom in electric vehicles started with Internal Combustion Engine (ICE) electro-hybrids in 1990s; the research on electrical powertrains and tools for their analysis were initiated to master the new technologies. Several tools have been developed for the purpose. The authors are aware of the following competent

simulation tools: ADVISOR⁵⁷, SIMPLEV⁵⁸, V-ELPH⁵⁹, CARSIM⁶⁰, HVEC⁶¹, CSM HEV⁶², PSAT and the later named Autonomie⁶³, PSIM⁶⁴, VTB⁶⁵.

Senger⁶⁶ explored the tools available and validated the tool called ADVISOR for the ICE-electro hybrid powertrain; the tool was validated in terms of energy consumption and emissions. The uncertainty of the tool was found to be within 10% for fuel consumption, but within 85% for emissions. The tool has been developed further, actively used, and is available for free. Markel et al.⁵⁷ presented an overview of ADVISOR written in the MATLAB/Simulink environment with the Graphical User Interface resembling its current outlook.

Rizzoni et al.⁶⁷ presented an outline for hybrid vehicle modelling and showed the benefits of a hybrid powertrain; their modelling approach was in general incorporating scalable models and taking into account the existing energy domains (chemical, thermal, mechanical, and electrical). Rizzoni et al.⁶⁷ developed a Simulink based model of an ICE-electro hybrid vehicle and indicated over 50% reduction in fuel consumption during a city driving.

Emadi et al.⁶⁸ carried out topological studies of ICE and fuel cell hybrid electric vehicle power system architectures. Fuel cell and hybrid powertrain topologies were presented. The benefit of the hybrid was shown as having a better load point for the ICE. Several topology options were presented and the design aspects of different topologies discussed.

⁵⁷ Markel, T., Brooker, A., Hendricks, T., Johnson, V., Kelly, K., Kramer, B. et al. ADVISOR: a systems analysis tool for advanced vehicle modeling, *J. Power Sources*, **110**(2), 255–266, Aug. 2002.

⁵⁸ Cole, G.H. SIMPLEV: A Simple Electric Vehicle Simulation Program, Version 2.0 User's Guide, USDOE Publication ID-10293-2, 1993, pp. 1–30.

⁵⁹ Ehsani, M., Gao, Y., Butler, K. Application of Electrically Peaking Hybrid (ELPH) Propulsion System to a Full Size Passenger Car with Simulated Design Verification, *IEEE Transactions on Vehicular Technology – Special Issue on Hybrid Electric Vehicles*, **48**(6), 1779–1787, Nov. 1999.

⁶⁰ Cuddy, M. A Comparison of Modeled and Measured Energy Use in Hybrid Electric Vehicles, SAE Technical Paper 950959, 1995.

⁶¹ Aceves, S., Smith, J. A Hybrid Vehicle Evaluation Code and Its Application to Vehicle Design, SAE Technical Paper 950491, 1995.

⁶² Braun, C., Busse, D. A Modular Simulink Model for Hybrid Electric Vehicles, SAE Technical Paper 961659, 1996.

⁶³ Halbach, S., Sharer, P., Pagerit, P., Folkerts, C., Rousseau, A. Model Architecture, Methods, and Interfaces for Efficient Math-Based Design and Simulation of Automotive Control Systems, SAE 2010-01-0241, *SAE World Congress*, Detroit, April 2010.

⁶⁴ Onoda, S., Emadi, A. PSIM-Based Modeling of Automotive Power Systems: Conventional, Electric, and Hybrid Electric Vehicles, *IEEE Transactions on Vehicular Technology*, **53**(2), 390–400, 2004.

⁶⁵ Gao, D.W., Mi, C., Emadi, A. Modeling and Simulation of Electric and Hybrid Vehicles, *Proceedings of the IEEE*, **95**(4), 729–745, 2007.

⁶⁶ Senger, R.D. Validation of ADVISOR as seen the Virginia Tech Futurecar Lumina, Master's Thesis, Virginia Tech University, 1997.

⁶⁷ Rizzoni, G., Guzzella, L., Baumann, B.M. Unified modeling of hybrid electric vehicle drivetrains, *IEEE/ASME Trans. Mech.*, **4**(3), 246–257, Sep. 1999.

⁶⁸ Emadi, A., Rajashekara, K., Williamson, S.S., Lukic, S.M. Topological overview of hybrid electric and fuel cell vehicular power system architectures and configurations, *IEEE Trans. Vehicular Tech.*, **54**(3), 763–770, May 2005.

Gao et al.⁶⁵ discussed different modelling methods such as physics-based and Bond Graph, which were presented using hybrid system modelling examples. The modelling and simulation capabilities of existing tools such PSAT, ADVISOR, PSIM, and VTB were demonstrated through application examples. The paper also presented the main physics governed by the model approaches.

The above studies mainly concentrate on hybrid passenger vehicles. The heavy-duty battery electric vehicles have received less attention, particularly validated examples.

Lajunen⁶⁹ studied different hybrid and fully electrical city bus concepts, their techno-economical aspects, and the total cost of ownership. The study included a set of simulations with different powertrain configurations and driving cycles. Similarly, the simulation tool was utilised to compute optimal speed profiles for an electrical city bus.⁷⁰

Rios et al.⁷¹ presented backward and forward modelling approaches in electric bus and electric bus fleet simulation. The basic fundamental equations to run and construct the simulator were shown. The simulator was validated via the measured battery state-of-charge.

4.1.2 Electric city bus model

A powertrain simulation model of a two-axled and rear-axle driven battery electric city bus was created in MATLAB/Simulink/Simscape environment. The modelled vehicle is a prototype bus that has been tested on a chassis dynamometer. The vehicle, which has also been in service over an actual operating route, was extensively instrumented to reveal the distribution of energy consumption. The main figures and components of the vehicle are given in **Table 3** and **Figure 35**.

⁶⁹ Lajunen, A. Energy consumption and cost-benefit analysis of hybrid and electric city busses, *Transportation research. Part C*, **38**, 1–15, 2014.

⁷⁰ Lajunen, A. Energy-Optimal Velocity Profiles for Electric City Busses, *IEEE International Conference on Automation Science and Engineering (CASE)*, pp. 886–891, 2013.

⁷¹ Rios, J., Sauras-Perez, P., Gi, A., Lorico, A., Taiber, J., Pisu, P. Battery Electric Bus Simulator – A Tool for Energy Consumption Analysis, SAE Technical Paper 2014-01-2435, 2014.

Table 3. Main parameters of the model.

Subsystem	Parameter	Value
Vehicle	Total mass, m	12 345 kg
	Frontal area, A	6.2 m ²
	Drag coefficient, C_d	0.5
	Rolling resistance, f_r	0.008
Drive motor	Nominal torque	1100 Nm
	Nominal speed	1800 rpm
Energy storage	Capacity	56 kWh
	Nominal voltage	614.4 V
	Charging current	90 A, max 125 A
	Discharging current	180 A, max 270 A
	Resistance, R	0.192 Ω

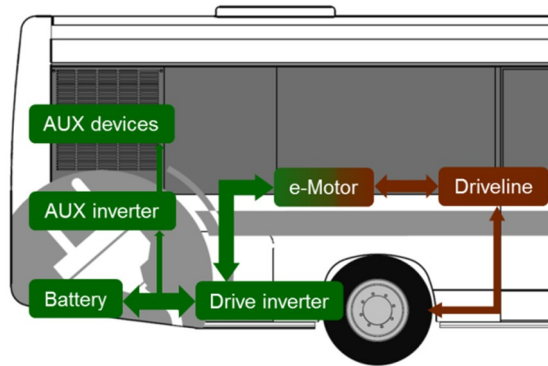

Figure 35. Electric powertrain sub-systems.

The subsystems of the bus powertrain are shown in **Figure 35** and the coupling of the main components in **Figure 36**. The model consists of the mechanical, electrical, and control domains. The mechanical domain contains the longitudinal dynamics of the vehicle and the mechanical power transmission line including rotating masses, the final drive, and the tires. The electrical domain contains the driving motor, power converter, and the battery. The control domain contains functions for the vehicle control unit (VCU) to regulate the motor torque and the wheel brakes. The VCU uses online measurements for feedback signals from the battery and the electric drive.

For validation purpose, the input to the system level model is the electric motor speed signal that have been recorded during driving the cycle with a prototype bus

on a chassis dynamometer. In addition, measured energy consumption of the auxiliary components was provided for the model, to emphasise the electric powertrain validation. Outputs are the measures from the system behaviour e.g. currents and voltages of the electric drive and the battery, longitudinal forces acting on the tires, motion of the vehicle, and mechanical power and torque of the drive motor.

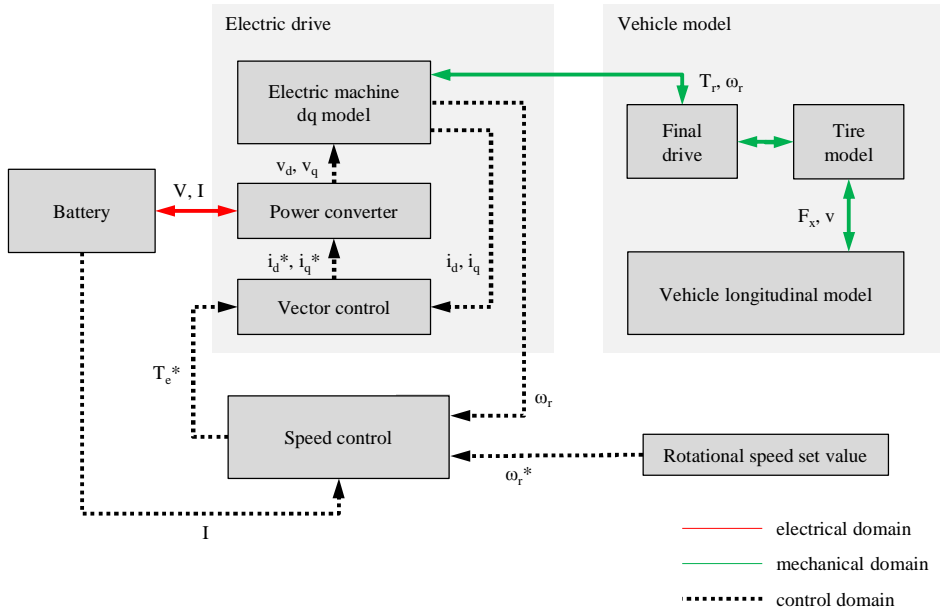

Figure 36. Coupling between the main components in the model as physical connections and with control signals. The symbols in the figure correspond to the ones used in the equations. Superscript * refers to the set value used in the control system.

Vehicle model

The vehicle model covers the longitudinal dynamics of the vehicle, taking into account the longitudinal weight shift of the vehicle during acceleration or deceleration. The equation of motion of the vehicle in the longitudinal direction is

$$m \frac{dv_x}{dt} = \hat{a} F_x - F_{loss} - mg \sin(b), \quad (2)$$

where m is the vehicle mass, v_x the longitudinal velocity, t time, β the road inclination angle, g the standard gravity, F_x the total longitudinal force of tires and F_{loss} the total driving resistance force.

The longitudinal force of the tire is modelled using Pacejka's Magic Formula.⁷² The force is expressed as a function of the vertical force F_z and the longitudinal slip. The coefficients of the tire model represent typical characteristics of a truck tire on dry asphalt surface.⁷³

Wheel brakes are modelled with a constant braking force distribution between the front and rear axle. In the simulation model, the wheel brakes are controlled by the VCU and activated only, if the braking effort coming from the regenerative braking is insufficient. In general, the aim is to produce the required deceleration by regenerative braking. However, the magnitude of the regenerative braking is limited due to the effective powertrain capacity, traction and eventually the bus stability.

Driving resistance model

The total driving resistance F_{loss} is expressed as

$$F_{loss} = F_r + F_d + F_{dl}, \quad (3)$$

where F_r is the rolling resistance of the tires, F_d is the aerodynamic drag and F_{dl} is the driveline loss. The model of the mechanical driveline includes inertias of the driveline, rims and tires and an ideal reduction gear of the final drive.

The rolling resistance is expressed as

$$F_r = f_r mg \quad (4)$$

where f_r denotes for the rolling resistance coefficient. The rolling resistance is assumed to be constant as a function of vehicle speed.

Aerodynamic drag, which is acting at the centre of mass of the vehicle, is expressed as

$$F_d = \frac{1}{2} C_d \rho A v_x^2 \quad (5)$$

where, C_d is the aerodynamic drag coefficient, ρ is air density and A is the frontal area of the vehicle.

Electric drive model

The electric motor, which is a permanent magnet synchronous machine (PMSM), is modelled in rotor fixed dq co-ordinates.⁷⁴ Inputs to the model are d and q voltages and outputs are d and q currents and the torque acting on the rotor. The model is based on the assumption that the induced electromagnetic force is sinusoidal. The

⁷² Genta, G. Motor vehicle dynamics: modeling and simulation, in *Series on Advances in Mathematics for Applied Sciences*, **43**, Singapore, World Scientific, 1997.

⁷³ Wong, J.Y. Theory of Ground Vehicles, New York, John Wiley & Sons, 1993.

⁷⁴ Manninen, A., Pippuri, J., Keränen, J.S., Tammi, K. Influence of the design choices on a permanent magnet synchronous machine, Poster in *15th Biennial IEEE conference on electromagnetic field computation (CEFC2012)*, Oita, 2012.

model takes losses into account via a look-up table, while magnetic saturation, eddy currents and hysteresis losses are not taken into account. Equations of the motor model are the following,⁷⁵

$$L_d \frac{di_d}{dt} = v_d - Ri_d + \omega_s L_q i_q \quad (6)$$

$$L_q \frac{di_q}{dt} = v_q - Ri_q - \omega_s L_d i_d - \omega_s \lambda_{af} \quad (7)$$

$$T_e = \frac{3}{2} P [\lambda_{af} i_q + (L_d - L_q) i_d i_q] \quad (8)$$

$$J_r \frac{d\omega_r}{dt} = T_e - T_L - B \omega_r \quad (9)$$

$$\omega_s = P \omega_r \quad (10)$$

In the equations, v_d and v_q are stator voltages in d , q axis, i_d and i_q are stator currents in d , q axis, L_d and L_q are d , q axis inductances, λ_{af} is the flux linkage due to rotor permanent magnets, R is the stator resistance, P is the number of pole pairs, ω_s is the electrical speed of the rotor, ω_r is the mechanical speed of the rotor, J_r is the rotor moment of inertia, T_e is the electrical torque acting on the rotor, T_L is the load torque acting on the rotor and B is the damping coefficient between the rotor and the stator. The torque acting on the wheel hub of the vehicle is computed from the output torque of the motor multiplied with the final drive ratio.

The electric motor is controlled using a vector controller. The torque demand is defined based on the difference between the reference and the actual speed of the rotor. The torque demand is converted into set values for d - and q - currents using vector control. In this study, an ideal power converter model is used to feed the electric motor. The ideal power converter can fulfil the d - and q - current requests in all conditions. The efficiency of the converter is assumed to be constant and it covers, for example, the switching losses of the converter. This approach enables faster simulations compared to an approach where the current control and power converter switches are modelled.

When the motor is run below the field weakening speed, the set value for d - current is set to zero. In the field weakening, the maximum q -axis current is limited to ensure constant power output. At the same time, a negative d -axis current is requested to neglect the back electromagnetic force coming from the permanent magnets of the rotor. Losses during the field weakening operation are taken into account using a look-up table.

⁷⁵ Pillay, P., Krishnan, R. Modeling, Simulation, and Analysis of Permanent-Magnet Motor Drives, Part I: The Permanent-Magnet Synchronous Motor Drive, *IEEE Trans. on Industry Applications*, **25**(2), 265–273, 1989.

The traction battery is modelled as a voltage source and a series resistor. The open circuit voltage V_{OC} of the battery is a function of the battery state of charge (SoC). The output voltage V is a function of battery current I due to the voltage drop caused by the series resistor describing the battery charging and discharging losses. Battery energy E_{bat} , and consequently SoC is computed using an energy balance between the battery and the power electronics; the energy charged or discharged is integrated from the power at each time instant:

$$E_{bat}(t) = E_{bat}(0) - \int_0^t V_{OC}(t)I(t)dt . \quad (11)$$

Current limits for charging and discharging the battery are defined and taken into account in the electric motor control system. Auxiliary devices of the vehicle are fed using a low voltage DC-DC converter that is connected to the DC-bus voltage. These auxiliary devices are the air compressor, the hydraulic pump of the power steering, and other minor auxiliaries.

4.1.3 Validation results

The simulation model is validated against measurements of the vehicle driven on a chassis dynamometer. Measurements signals are gathered from the vehicle CAN bus and from a power analyser connected to the battery. The used driving cycle is an actual bus operation route 11 in Espoo Finland, having a length of 9.1 km. For validation purpose, the measured drive motor speed was used as an input for the model speed reference and the measured auxiliary component energy consumption was used as the auxiliary energy consumption in the simulation. **Figure 37** and **Figure 38** show the simulated and measured results as key performance values. On the left side of **Figure 37**, is presented the battery cumulative energy in both charging and discharging directions, and the vehicle speed. These energy consumption values do not include battery losses, since the measurement on the prototype bus was from the battery output power. The measured energy consumption was 5.30 kWh and simulated 5.38 kWh. When taking into account the realised actual speed profile for the simulation run, the average consumptions were 0.581 kWh/km and 0.589 kWh/km for the measured and simulated respectively. The minor difference between the speed profiles is due to the inaccuracies in speed controller tuning.

On the right side in **Figure 37** is presented the electric drive input current, the output power and the torque during a partial time frame of the driving cycle. **Figure 38** shows the battery output voltage and current during the same time frame. As seen in **Figure 37** on the left side, the simulated and measured energy consumption has a good correspondence both in charging and in discharging directions. This means that the losses in the powertrain and the work done on driving resistances are of the right magnitude. The battery output voltage during charging and discharg-

ing has a difference, as seen in **Figure 38**. When the energy consumption is computed from the battery output power, it adds a small error into the total energy consumption.

The inverter DC current, motor output torque and power have good correspondence with the measured values, as seen in the right side of **Figure 37**. Differences between the measured and simulated current, torque, and power values are mainly caused by the fast transitions of the measured current, torque, and power values, which are not seen in the simulated values. These transitions are due to the actual acceleration and brake pedal controls given by the driver. However, these rapid torque changes are not seen in the measured vehicle or motor speed. Since the measured motor speed is used as a speed reference for the simulation model, transitions do not exist in the simulated current, torque and power values. As a result of this, the operation point of the motor is not identical in every time instant, leaving out some high torque points in the simulation. The used bus route cycle was light in terms of accelerations, resulting in rather low energy consumption. In addition, field-weakening speed was met only a few times. The driver's driving style has a less significant effect in this kind of cycle, since the motor operation point is mostly inside the high efficiency area.

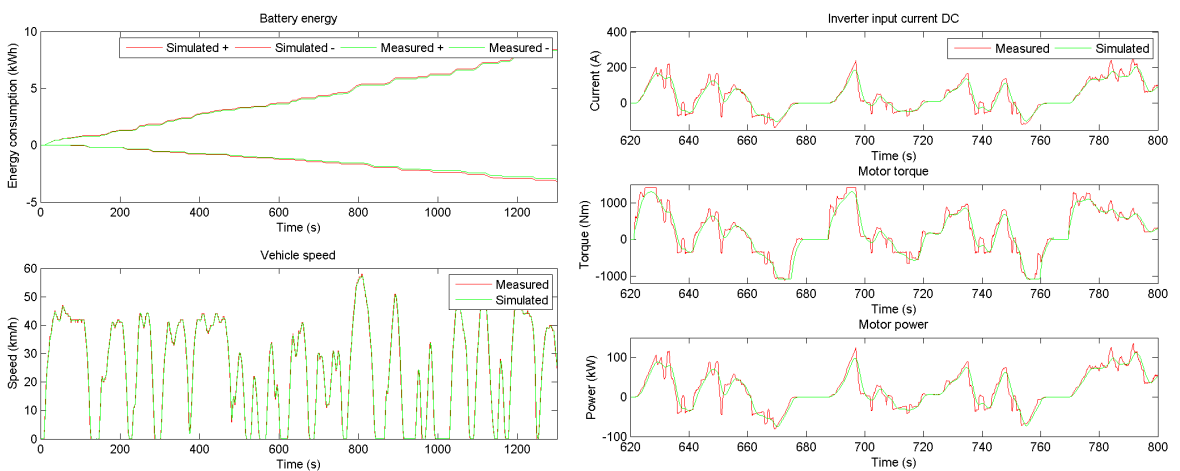

Figure 37. Cumulative battery charging and discharging direction energy and vehicle speed for total cycle length without battery losses (left). Electric drive input current and output torque and power during part of the cycle (right).

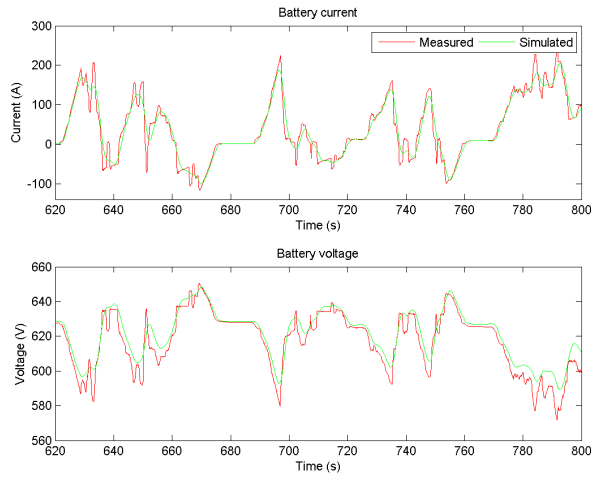

Figure 38. Battery current and voltage during part of the cycle.

4.1.4 Discussion

Even though the simulated and measured responses were in good agreement, the model naturally has some limitations and simplifications. The electrical motor model was based on the dq formulation. The inverter model was an ideal current controller. The battery model uses only one resistance component, neglecting capacitance completely. The effect of cell temperature was not taken into account, either. The model does have the effect of SOC for open circuit voltage, based on the curve provided by the battery manufacturer. Other dynamics such as resistance change is not included. The powertrain was modelled as an ideal powertrain, but speed-dependent losses were added as lumped powertrain losses together with rolling resistance and aerodynamic drag.

Although the total energy consumption in the simulation was higher than the measured, the positive direction (discharged) energy was lower in the simulation (1.2%). The biggest difference for the total energy consumption comes actually from the regenerated energy, which is not high enough in the simulation (5.6% lower than measured). This can be a result of different operation points of the motor, because the regenerative braking is applied in a very transient manner, while in the simulation the braking is smoother, resulting in denser use of mechanical wheel brakes.

The detail level of the simulation model used in this work is sufficient for studies on the system level behaviour. The model of vehicle longitudinal dynamics together with the dq model of the electric machine gives an opportunity for component sizing as well as control system studies. The simulation time of the model is about five times faster than real time, when calculated using a normal laptop computer, which is a reasonable calculation effort also for larger parameter studies.

4.1.5 Conclusion

This paper shows a validation of the battery electric city bus and corresponding simulation model developed for heavy vehicle research. The bus is a prototype vehicle, which has been converted from a diesel bus. The simulated energy consumption, the electric motor torque and power, the battery current and voltage were in good agreement with the measured ones. The difference in energy consumption over the cycle was 1.4%. Using the proposed computer simulation approach, highest consuming subsystems can be identified and the powertrain can be optimised for desired operation profile to achieve overall energy efficient vehicle configuration.

The driving cycle based on the local bus line included no intermediate charging. Also, the heat dissipation due to operation was neglected. The thermal behaviour is known to be important in terms of the total efficiency. The bus thermal model to take into account the dynamic charging and discharging power limits for the system is under development by the authors. In addition, auxiliary component model including heating and cooling with cabin airflow is to be studied.

4.1.6 Acknowledgements

The authors acknowledge the financial support for the research work that received from the Electric Vehicle Systems (EVE) programme funded by Tekes – the Finnish Funding Agency for Technology and Innovation.

4.2 Electric city bus demonstration environment – results from laboratory tests on commercial buses

Authors: Teemu Halmeaho, Juhani Laurikko, Ari-Pekka Pellikka, Seppo Kallonen, Mikko Pihlatie

Affiliations: VTT Technical Research Centre of Finland Ltd

Contact information for main author: mikko.pihlatie@vtt.fi

Abstract

To study the differences in performance of commercial electric city buses, comprehensive laboratory testing was carried out for six fully electric buses in operation in route 11 in Espoo. All of the 12 m buses were equipped with LFP chemistry batteries, with capacity ranging from 56 kWh to 324 kWh. The buses had also a wide variety of different drivetrain configurations.

The chassis dynamometer measurements in a controlled laboratory environment at VTT were performed using five driving cycles with three payloads. This paper describes the energy consumption comparison of the six buses covering two bus cycles using two payloads. Average consumption of the buses in the Braunschweig cycle with 40 passengers was 1.15 kWh/km, while the equivalent diesel bus consumed 4.5 kWh/km in the earlier studies. The most efficient electric bus was using 32% less energy than the average, and the least efficient 17% above average. The

differences originated mainly from the curb weight of the buses, energy efficiency of the powertrain and the capability to regenerate the kinetic energy.

4.2.1 Introduction

Mobility of people and goods are essential functions for today's society, but both are undergoing transformation. Key challenges for today's transport systems are improving energy efficiency, reducing carbon emissions from vehicles, cutting local emissions and noise, as well as alleviating congestion. However, advances in conventional vehicle and engine technologies no longer solve the problems, with a wider array of options needing to be employed.

In urban environments, public transport services need to form the backbone of the mobility, and buses have traditionally offered more flexibility than rail-based systems, though due to the direct-electric drive, rail has been considered more environmentally friendly. However, battery-electric buses are now capable of breaking this paradigm, and have the potential to dramatically reduce the carbon footprint, local emissions and noise of city bus transport.

Since Finland has quite a challenging climate and the battery electric buses are still in a pre-commercial stage, the decisions to start the electrification of buses in the area were backed up with a launch of a comprehensive research and demonstration project called 'eBus' during 2012–2016. The demonstration was a combination of field and laboratory testing of battery-electric buses, operated by Transdev Finland in real-world conditions and in real revenue service within an existing bus route 11 in the city of Espoo. The route is quite representative of the type of feeder traffic to the metro, which is scheduled to start service in this part of the Helsinki Metropolitan region in the autumn of 2017.

VTT has together with several partners created a multi-dimensional demonstration environment for electric buses and their supporting infrastructure. The 'eBus' project demonstration in the city of Espoo is currently followed by the pre-commercial pilot project 'ePELI' by Helsinki Region Transport (HSL), see also section 2.3.3.1 on the 'ePELI'. These projects are unique in many aspects. One relates to the weather: due to local climate conditions, the ambient temperature can swing up to 60 °C between high summer and mid-winter. This certainly stresses the vehicles and their batteries to their limits at both ends of their operational range. Furthermore, maintaining comfortable riding conditions requires sufficient heating and cooling of the passenger compartment.

Another important feature of the 'eBus' demonstration and field-trial run is that several different commercially available buses are operated simultaneously on the same line. This approach gives an excellent opportunity for benchmarking. Furthermore, the service operations in real driving are supported with chassis dynamometer measurements in a controlled laboratory environment at VTT. Lab measurements enable more accurate determination of the energy use profile in different duty-cycles, and make it possible to resolve the contribution of the on-board subsystems.

4.2.2 eBus fleet

In practice, no research information has been established on the general standard of technology in electric city buses, and development has only begun in earnest over the last few years. Individual bus testing that emphasises the product design of an individual bus has been carried out by some universities and research centres.^{76,77,78,79,80} In fact, the objective of the eBus project was to generate such information on the current standard of commercial buses. Five buses from different OEMs were taken in service. In addition, a prototype fully electric bus 'eMule', which was developed and built in conjunction with VTT, Aalto University and Helsinki Metropolia University of Applied Sciences, was in operation for short test periods. **Table 4** lists all the six full-size 12-metre buses, their main specifications, and when they have entered into service.

⁷⁶ Resino Zamora, D., López Martínez, J.M., Loboguerrero Carrasco, C.J., Delgado Vaca, J.J. Development of an in-series hybrid urban bus model and its correlation with on-board testing results, in *Proc. International Battery, Hybrid and Fuel Cell Electric Vehicle Symposium (EVS27)*, Nov. 2013, pp. 1–11.

⁷⁷ Töpler, F., Eckstein, L., Geulen, G. Homann, J. *econnect* Germany – performance and evaluation of an electrically propelled minibus for public transportation, in *Proc. International Battery, Hybrid and Fuel Cell Electric Vehicle Symposium (EVS27)*, Nov. 2013, pp. 1–7.

⁷⁸ Bubna, P., Brunner, D., Gangloff Jr., J.J., Advani, S.G., Prasad, A.K. Analysis, operation and maintenance of a fuel cell/battery series-hybrid bus for urban transit applications, *Journal of Power Sources*, **195**(12), 3939–3949, Jun. 2010.

⁷⁹ Tanaka, K. et al. Design, Manufacture, and Environmental Sustainability Evaluations of Advanced Electric Medium Duty Bus "WEB for Suntory", in *Proc. International Battery, Hybrid and Fuel Cell Electric Vehicle Symposium (EVS27)*, Nov. 2013, pp. 1–9.

⁸⁰ Wang, X., Avila González, J. Assessing Feasibility of Electric Buses in Small and Medium-Sized Communities, *International Journal of Sustainable Transportation*, **7**(6), 431–448, 2013.

Table 4. List of electric buses in the eBus trial.

Maker	Model	Entry in service	Battery capacity (kWh)	Nominal power (kW)	Drive	Total mass (kg)
Caetano Cobus	EL2500	Oct 2012	150	150	FWD, two gears	18 000
VTT Prototype	eMule	Oct 2012	56	207*	RWD	15 000
Ebusco	YTP-1	Dec 2013	242	150	RWD	17 500
VDL	Citea SLF-120 EL	July 2014	85	226	RWD, inWheel motors	17 800
BYD	eBUS-12	July 2014	324	150	RWD, inWheel motors with hub gear	18 000
Ebusco	2.0	Apr 2015	311	150	RWD	17 500

*The drive motor of eMule was replaced in April 2015 with a smaller motor having nominal power of 112 kW.

All the tested buses have LFP chemistry Li-Ion batteries of variables sizes. For eMule, the battery was replaced with LTO battery of the same capacity in December 2015. The LFP batteries are only suitable for low-power charging, which means these buses need to be charged overnight in a bus depot or taken out of the service for a couple of hours during the day to recharge them. The buses from Ebusco and BYD are clearly intended for overnight charging due to their high capacity batteries. These high capacity batteries can accept higher charging power, which increases the capability to regenerate kinetic energy. Another notable difference amongst the buses is the variety in drivetrain configurations. The most common setup is the traditional diesel-bus driveline, where the diesel motor has been replaced with an electric motor driving the rear-wheels through a differential gear. Two of the buses have a special rear-axle, where each wheel has an in-wheel motor inside the rear wheel. One is implemented with an integrated gear and another as direct drive. The most uncommon setup is the front-wheel driven bus with two-speed transmission. Different approaches for implementing the driveline are seen because manufacturers are searching for a cost-optimal configuration. A direct drive electric motor inside the wheel without any gear should be a simple and energy efficient solution, but the motor itself needs to have small dimensions and produce higher torque than the one with gearing.

4.2.3 Testing method

The energy consumption tests were conducted on a heavy-duty chassis dynamometer capable of simulating the inertia weight and road loads that buses are subjected

to during normal on-road operation. The basic chassis dynamometer test procedures used in EV measurements is directly adopted from VTT's normal test procedures for conventional vehicles.⁸¹ Furthermore, VTT has developed electric energy consumption measurement methods for both passenger cars and buses.

For measurements of heavy-duty vehicles, VTT uses a single-roller, 2.5-meter diameter chassis dynamometer with electric inertia simulation. The system has the capability of testing vehicles from 2500 to 60000 kilograms. Maximum absorbed power (continuous) is 300 kW at the driving wheels. **Figure 39** presents a picture of the VTT test facility.

VTT has developed its own in-house method covering both emission and fuel consumption measurements, partly based on SAE J2711⁸². In June 2003, FINAS, the Finnish Accreditation Service, granted accreditation to VTT's method. This method together with the experience gathered in light-duty battery electric vehicles measurements have been used as the starting point for the development of heavy-duty battery electric vehicles measurement method.



Figure 39. Heavy-duty vehicle test facility at VTT enables simulation of driving in a controlled laboratory.

Driving resistance model

To make the drive motor experience the same load as if the bus was driving on a road, VTT uses a road-load model that is based on coast-down measurements on

⁸¹ Nylund, N.-O., Koponen, K. Fuel and technology options for buses. Overall energy efficiency and emission performance, VTT Technology 46, Espoo 2012. 294 p. + app. 94 p. Available at: <http://www.vtt.fi/inf/pdf/technology/2012/T46.pdf> [Accessed 7 Dec 2015].

⁸² SAE Standard J2711 Recommended Practice for Measuring Fuel Economy and Emissions of Hybrid-Electric and Conventional Heavy-Duty Vehicle, Society of Automotive Engineers, Document No. J2711, 2002.

the road. This way the aerodynamic drag, rolling resistances on a real road surface, and the resistance of the non-driven axle are included into the dynamometer driving. The settings for the dynamometer are determined by deducing the rolling resistances of the freely rolling tyres and the freely spinning axle from the total resistance values. When testing vehicles on the chassis dynamometer, VTT uses a special set of tyres with longitudinal grooves only to normalise the effects of tyres between vehicles. Normally, these kinds of tyres are used only on non-driving steering axles. On some commercial buses, it was not possible to change the tyres of the bus, causing a problem in the measurement procedure. In order to work around this, coast-down tests for these kinds of buses were performed and the rolling resistance was calculated based on that test.

Tested properties

To study the performance under different operation conditions, the driving cycle and amount of passengers is varied. Five different cycles were used: Espoo route 11,⁸³ Braunschweig, London, New York, and Ademe. The payload is varied as 1000 kg, 3000 kg and full load. For a heavy-duty vehicle running a highly transient drive cycle, the mass of the vehicle is decisive for driving resistances. Vehicle mass affects the inertia as well as rolling resistance. In addition, a battery capacity test was carried by driving the vehicle on route 11 cycle as long as there is charge left, although it is usually interrupted by the Battery Management System some percentage units before reaching zero.

Component specific energy consumption

The power consumption was measured from all main electric energy consuming components separately, but simultaneously in synchronous time intervals. To ensure the reliability of the data, the authors used two different measurement devices in parallel, which were connected to the same measurement points in the electric systems on a bus. Only the biggest electric energy consumers were measured (**Figure 40**). Measurement points for DC voltage (V) and current (A) were:

- Traction battery energy
- Drive motor inverter energy
- Air compressor energy
- Power steering energy
- 24 V auxiliaries energy
- Traction battery charger energy, from AC grid

In addition, the raw data from vehicle's CAN-bus were collected. The dynamometer control system measures the driving force between the roll and the tyre, and also the speed of the roll.

⁸³ Laurikko, J., Pihlatie, M., Nylund, N.-O., Halmeaho, T., Kukkonen, S., Karvonen, V. et al. Electric city bus and infrastructure demonstration environment in Espoo, Finland, in *Proc. EVS28*, Goyang, Feb. 2015.

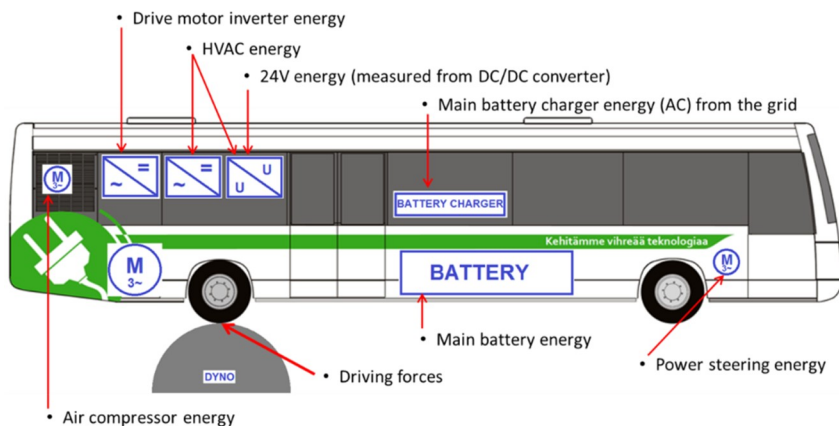

Figure 40. Measurement points during dynamometer testing.

4.2.4 Results

The performance of the buses was compared on two different cycles (Espoo route 11 and Braunschweig) with two payloads (1000 kg and 3000 kg). VTT use Braunschweig as a reference cycle for testing city buses and comparing the different bus technologies. The performance requirement in Braunschweig is higher than in route 11. The following results are presented in anonymous manner (buses ‘renamed’ from A to F in an arbitrary order) as requested by the bus manufactures attending the demonstration. The relative energy consumption in these cycles for each bus in comparison to the average consumptions of the measured buses are presented in **Figure 41**. Energy consumptions, which are split into the energy taken from the battery (+work) and into the energy recovered into the battery (-work) are visualised in **Figure 42** and **Figure 43**, for route 11 and Braunschweig, respectively.

From the results, it can be seen that Bus B required much less energy to perform the cycles. However, it managed to regenerate energy only at the average level. Bus A, on the other hand, consumed notably more than others in the +work direction, but it also recovered more energy. Buses C and D performed in similar manner; both had average +work consumption but poor regeneration capability. The performance of buses E and F was at the average level in both directions.

For the results of bus D, it should be noted that the used payload was 20% smaller than with other buses. In addition, for buses D and F it was not possible to change the measurement tyres, making the measurement procedure non-standard, resulting in too small energy consumption values.

Average energy consumption of the buses in the Braunschweig cycle was 1.15 kWh/km, while the consumption of diesel reference has been measured to be 4.5 kWh/km⁸⁴.

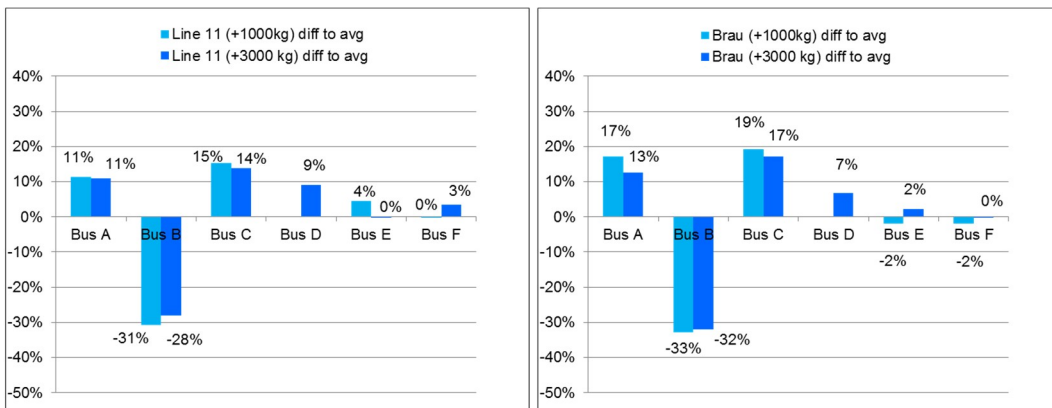

Figure 41. Relative difference in total battery energy consumption to the average consumption of the buses (smaller value is better). Two payloads were used for both route 11 (left) and Braunschweig (right).

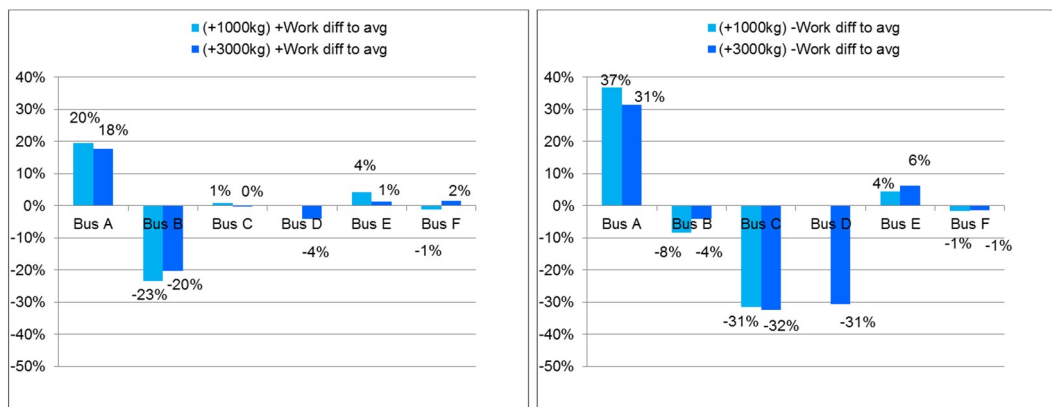

Figure 42. Relative difference in energy consumption to the average consumption of the tested buses in route 11 cycle with two payloads. The energy consumptions are separated into energy taken from the battery (left) and energy recovered (right). On the left, smaller value is better and on the right higher value is better.

⁸⁴ Erkkilä, K. et al. Energy efficient and intelligent heavy vehicle – HDENIQ Final report. [pdf] Espoo, Finland: VTT Technical Research Centre of Finland. 2012. Available at: http://www.transec.fi/files/783/Energy_Efficient_And_Intelligent_Heavy_Vehicle_HDENIQ_Final_Report_VTT-R-08344-12.pdf [Accessed 7 Dec 2015].

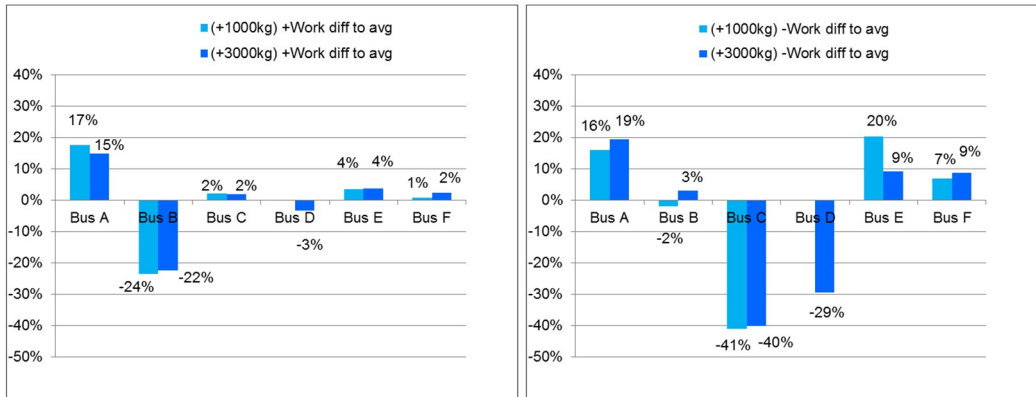

Figure 43. Relative difference in energy consumption to the average consumption of the tested buses in Braunschweig cycle with two payloads. The energy consumptions are separated into energy taken from the battery (left) and energy recovered (right). On the left, a smaller value is better and on the right, a higher value is better.

4.2.5 Discussion

The +work direction battery energy consumption is dominant in the total energy consumption, as its portion is larger than the corresponding -work direction battery energy, since the driving resistances and the limited efficiency of the powertrain components cut a major slice of the available kinetic energy. The biggest factors for the +work direction energy consumption are the mass of the vehicle and the powertrain component efficiencies. The empty mass of the buses varied within 9300–14700 kg. In addition, as was seen in **Table 4**, the driveline configurations vary between the buses, therefore the powertrain efficiencies also vary.

For the -work direction, the capability to regenerate energy is affected by the vehicle mass and also the component efficiencies. Now the heavier bus has more kinetic energy available, but the LFP battery may not be capable of accepting the high-power recharge. The bigger vehicle mass is often a result of higher capacity and therefore a heavier battery. As the higher capacity battery can accept higher power, a heavier bus can often recover the higher available energy. However, the maximum regenerative power is usually limited by the vehicle control system to guarantee stable braking,⁸⁵ as the electric motor braking applies only to the driving wheels.

Based on the results it is evident that the drivetrain type and the battery configuration will have an effect on the energy consumption in electric city buses. The bus should be designed and selected to match the specific operational need.

⁸⁵ Halmeaho, T., Rahkola, P., Pippuri, J., Tammi, K. Hybrid City Bus Design Evaluation Using System Level Simulations, in *Proc. ISIE 2014*, 2014. DOI:10.1109/ISIE.2014.6864866.

4.2.6 Conclusions

As battery electric buses are still in a pre-commercial stage, a demonstration environment and a research project to study them was established. The demonstration was a combination of field and laboratory testing of battery-electric buses. The method and results of the laboratory testing were described in the paper. Although all six of the 12-meter LFP battery electric city buses were intended for identical operation, significant differences in the implementation and performance were found amongst the bus fleet. Average consumption on a Braunschweig cycle, which describes a common Central European city bus driving cycle, with 40 passengers was 1.15 kWh/km. During on-road operation, auxiliary components would be more active, increasing the consumption by 0.1 kWh/km. Heating or cooling would add another 0.23 kWh/km to produce 8 kW of heating power. In addition, the LFP battery regenerative power would be lower in a cold environment if it does not have an integrated pre-heating system. The lack of preheating would affect negatively also the battery lifetime. The current trend in electric bus batteries is towards capacity downsizing and using an LTO anode chemistry instead of graphite anodes combined with an LFP cathode. This trend reflects the need to enable the high-power opportunity charging instead of overnight charging. Another big advantage of LTO is the capability to capture all the available kinetic energy, as long as the drive motor and the inverter can handle it.

4.2.7 Acknowledgements

The authors acknowledge the financial support for the research work that received from the Electric Vehicle Systems (EVE) programme funded by Tekes – the Finnish Funding Agency for Technology and Innovation.

4.3 Evaluation of energy consumption and carbon dioxide emissions of electric city buses

Authors: Antti Lajunen, Kari Tammi

Affiliations: Aalto University

Current contact information for main author: antti.lajunen@helsinki.fi

Abstract

This research presents a complete breakdown analysis of the energy consumption and carbon dioxide emissions for electric city buses. Different primary energy pathways for electricity are analysed in terms of energy efficiency and emissions. The energy losses for charging and bus operation are evaluated based on the simulations carried out in the Autonomie vehicle simulation software. Different types of driving cycles and operation conditions are used in simulations. The results show in detail the breakdown for the energy consumption and carbon dioxide emissions for the different energy pathways.

4.3.1 Introduction

Electricity for vehicle use can be produced in many different ways and, depending on the pathway, are usually referred to as well-to-tank (WTT) or well-to-pump (WTP), with different amounts of energy used and emissions produced.⁸⁶ The primary energy sources (coal, nuclear, natural gas, etc.) have an important impact on the energy efficiency and carbon dioxide (CO₂) emissions of electricity production. Since geographical locations have different availability of primary energy sources, it is important to take into account the local electricity production when analysing the energy efficiency and carbon dioxide emissions of electric city buses, as it was shown in a recent research study in the USA.⁸⁷ In European countries, there is significant variability in CO₂ emissions due to differences between electricity generation pathways. This was shown in extensive research by the European Commission⁸⁶ and by Eurostat.⁸⁸ According to the research studies, electricity produced from fossil energy sources has CO₂ emissions between 150–300 g/MJ. CO₂ emissions from renewable energy sources are minimal, and they could be even negative e.g. when biogas is used for producing electricity.⁸⁶ When defining CO₂ emissions of vehicles, emission values of the electricity grid mix are often used. In a Spanish study,⁸⁹ the grid mix CO₂ emissions were 104.5 g/MJ, and in another European study,⁹⁰ the electricity grid mix CO₂ emissions were 138.0 g/MJ. The yearly average CO₂ emissions of the electricity production in Finland was 32.8 g/MJ in 2015.⁹¹

Electric city buses are becoming more and more competitive with traditional diesel city buses because of their superior energy efficiency and zero emission operation.⁹² The main reason for the success of battery electric buses are lithium-based batteries and advanced charging technologies.⁹³ In the past, other types of battery

⁸⁶ Edwards, R., Larivé, J.F., Rickeard, D., Weindorf, W. Well-to-Tank Report Version 4.0, JRC Technical Reports, 2013.

⁸⁷ Xu, Y., Gbologah, F.E., Lee, D.Y., Liu, H., Rodgers, M.O., Guensler, R.L. Assessment of alternative fuel and powertrain transit bus options using real-world operations data: Life-cycle fuel and emissions modeling, *Applied Energy*, **154**, 143–159, September 2015.

⁸⁸ Eurostat, Electricity production and supply statistics, http://ec.europa.eu/eurostat/statistics-explained/index.php/Electricity_production_and_supply_statistics, (accessed on 9-Feb-2016).

⁸⁹ García Sánchez, J.A., López Martínez, J.M., Lumbreras Martín, J., Flores Holgado, M.N., Aguilar Morales, H. Impact of Spanish electricity mix, over the period 2008–2030, on the Life Cycle energy consumption and GHG emissions of Electric, Hybrid Diesel-Electric, Fuel Cell Hybrid and Diesel Bus of the Madrid Transportation System, *Energy Conversion and Management*, **74**, 332–343, October 2013.

⁹⁰ Thiel, C., Schmidt, J., Van Zyl, A., Schmid, E. Cost and well-to-wheel implications of the vehicle fleet CO₂ emission regulation in the European Union, *Transportation Research Part A: Policy and Practice*, **63**, 25–42, May 2014.

⁹¹ Finnish Energy, Energy Year 2015 – Electricity, <http://energia.fi/en/slides/energy-year-2015-electricity>, (accessed on 9-Feb-2016).

⁹² Lajunen, A., Energy consumption and cost-benefit analysis of hybrid and electric city buses, *Transportation Research Part C: Emerging Technologies*, **38**, 1–15, January 2014.

⁹³ Göhlich, D., Künith, A., Ly, T. Technology assessment of an electric urban bus system for Berlin, *Urban Transport XX*, 2014, pp. 137–149.

technologies were used in city buses such as molten salt batteries,⁹⁴ though modern electric city buses are powered by lithium-ion batteries.⁹⁵ Due to the flexibility of the electric powertrain, different design solutions can be achieved as shown in literature.^{96, 97} The most typical powertrain solution is to use one or two electric traction motors directly connected via a differential gear to the wheels without a gearbox⁹⁸ or with a fixed reduction gear between the motor(s) and differential gear.⁹⁹ A full electric powertrain has very high energy conversion efficiency of around 80–85%, depending on the powertrain design, operating cycle, and conditions. The recent trend is to have a smaller battery pack (energy capacity < 100 kWh) and charge the battery during operation either at specific bus stops (opportunity charging) or at the end stations.^{99, 100} In this way, the operation is not dependent on the battery capacity, and also, less investments are needed for expensive batteries. The charging efficiency depends on the power and is usually better than 80%. High charging current increases the losses in the charging device and especially in the battery. Due to the high-power acceptance of lithium-ion batteries, braking energy can be recovered at high efficiency, which significantly improves the total energy efficiency of electric buses.⁹⁶ Despite of the technological advantages, battery electric buses still have higher lifecycle costs than diesel or hybrid city buses.⁹²

A typical operation of city buses includes rapid accelerations and decelerations between bus stops in city centre or urban areas. Electric buses are much less impacted by the driving cycle than diesel buses because of the higher efficiency powertrain and possibility for regenerative braking.⁹² The major challenges in the operation relates to the charging infrastructure and operating conditions. When operating in cold or hot ambient temperature, the energy consumption of the HVAC (Heating, Ventilation, and Air Conditioning) systems may be higher than the propulsion energy consumption.^{93, 95} As the electric powertrain does not produce a lot of

⁹⁴ Lodi, G., Manzoni, R., Crugnola, G. Batteries for full electric and hybrid buses: fleet operation results and relevant battery improvements, The 25th World Battery, Hybrid and Fuel Cell Electric Vehicle Symposium & Exhibition, Shenzhen, China, November 5–9, 2010.

⁹⁵ Budde-Meiwes, H., Drillkens, J., Lunz, B., Muennix, J., Rothgang, S., Kowal, J., Sauer, D.U. A review of current automotive battery technology and future prospects, Proceedings of the Institution of Mechanical Engineers, Part D: Journal of Automobile Engineering, **227**(5), 761–776, April 2013.

⁹⁶ Lajunen, A. Powertrain Design Alternatives for Electric City Bus, IEEE Vehicle Power and Propulsion Conference, Seoul, Korea, October 9–12, 2012, pp. 1–6.

⁹⁷ Lajunen, A. Comparison of Different Powertrain Configurations for Electric City Bus, IEEE Vehicle Power and Propulsion Conference (VPPC), Coimbra, Portugal, October 27–30, 2014.

⁹⁸ Pihlatie, M., Kukkonen, S., Halmeaho, T., Karvonen, V., Nylund, N.-O. Fully electric city buses - The viable option, IEEE International Electric Vehicle Conference (IEVC), Florence, Italy, December 17–19, 2014, pp. 1–8.

⁹⁹ Festner, L., Karbowski, G. Foothill Transit Ecoliner Electric Bus Program, EVS26 International Battery, Hybrid, and Fuel Cell Electric Vehicle Symposium, Los Angeles, CA, USA, May 6–9, 2012.

¹⁰⁰ Rogge, M., Wollny, S., Sauer, D.-U. Fast Charging Battery Buses for the Electrification of Urban Public Transport—A Feasibility Study Focusing on Charging Infrastructure and Energy Storage Requirements, *Energies*, **8**(5), 4587–4606, May 2015.

waste heat¹⁰¹, a significant amount of battery energy has to be consumed heat the interior spaces in cold ambient conditions.

This research presents an exhaustive analysis of the energy consumption of electric city buses. Two different types of battery electric city buses were modelled and analysed. The first bus type is suitable for operation with opportunity charging and the other for overnight charging. Based on the simulation results, the energy consumption was evaluated in terms of powertrain, driving cycle, ambient conditions (temperature) and passenger load. The carbon dioxide emissions were also analysed. First, the electricity production and generation pathways are described in a European context. Secondly, the energy efficiency and CO₂ emissions of the different pathways were defined based on recent statistical data. Based on the energy consumption values in operation, the total energy consumption and CO₂ emissions were calculated for different driving cycles.

4.3.2 Electricity production and pathways

Carbon dioxide emissions from electricity generation are heavily dependent on the electricity production pathway. There are substantial differences between countries and geographical regions in energy sources and CO₂ emissions. In this research, the focus is on Europe with a specific study done for Finland. **Figure 44** presents electricity production by energy sources in European Union (EU) 28 countries and in Finland.^{88,91} In Finland, very little electricity is produced by combustible fuels and a significant amount of energy is produced by nuclear power.

Figure 45 presents electricity production by energy sources for all EU-28 countries. It can be seen that many of the countries are still using a lot of conventional thermal energy sources for electricity production. The electricity generation pathways, total energy balances and carbon dioxide emissions were exhaustively studied in the Well-to-Tank report by JRC (Joint Research Center).⁸⁶ **Figure 46** shows some of the typical electricity generation pathways as presented in the study. The figure includes pathways for natural gas (GPEL1a/b/bC, GREL1), coal (KOEL1, KOEL2/2C), wind (WDEL1), and EU fuel mix (EMEL1). The descriptions of these pathway variants are given in **Table 5**, which also presents the energy balance and CO₂ emissions.

¹⁰¹ Lajunen, A., Kalttonen, A. Investigation of Thermal Energy Losses in the Powertrain of an Electric City Bus, IEEE Transportation Electrification Conference and Expo (ITEC'15), Dearborn, MI, USA, June 14–17, 2015.

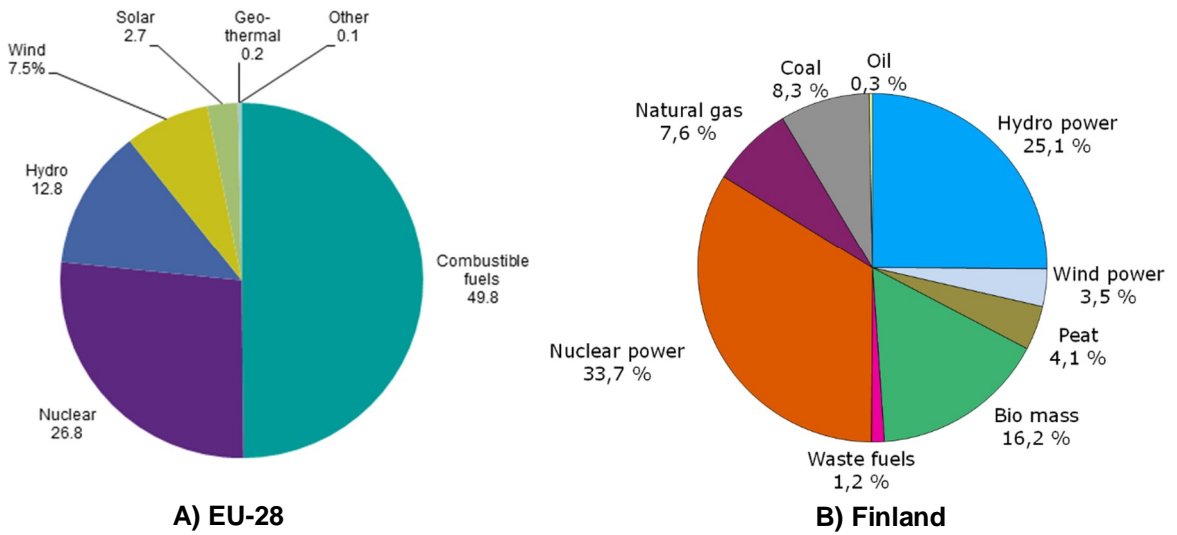

Figure 44. Electricity production by energy sources A) EU-28 countries,⁸⁸ and B) Finland.⁹¹

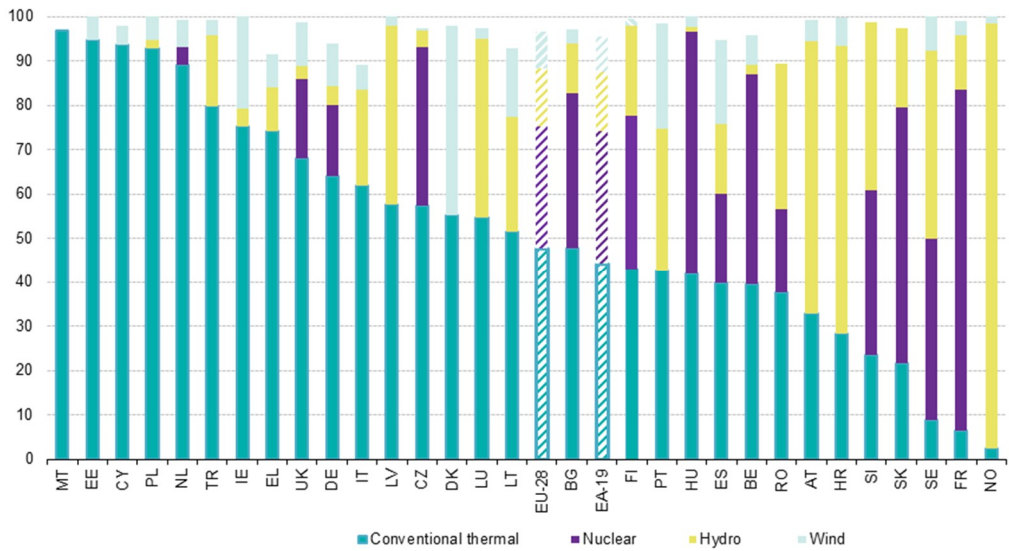

Figure 45. Breakdown of electricity production by source in EU-28 countries.⁸⁸

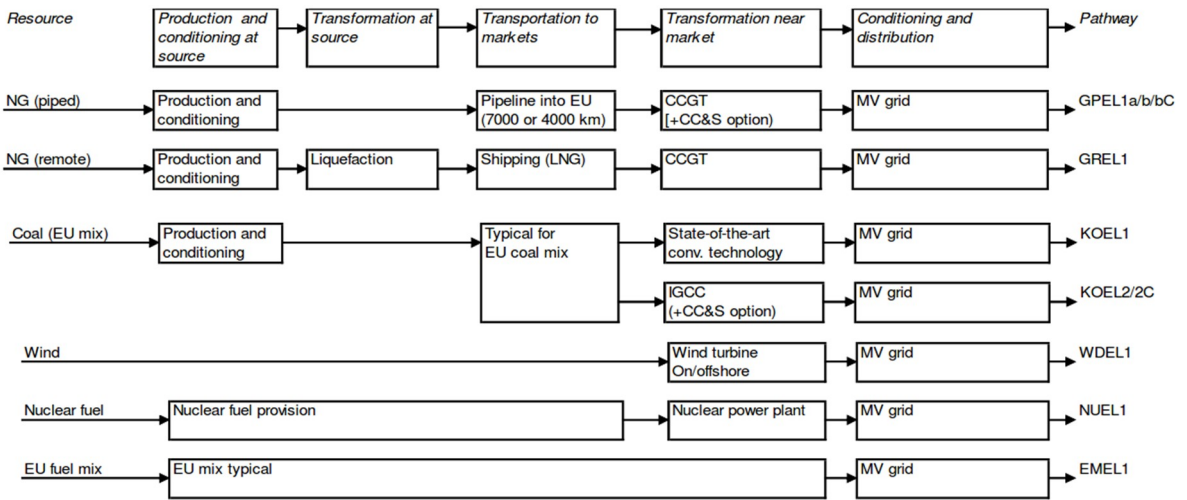

Figure 46. Electricity pathways from natural gas (NG), coal, wind, nuclear fuel and EU fuel mix.⁸⁶

Table 5. Energy balances and carbon dioxide emissions for different electricity generation pathways.^{86, 91}

Pathway	Description	Expended energy (MJ/MJ _{fuel})	GHG emissions (g CO _{2eq} /MJ _{fuel})
EMEL1	EU-mix (high voltage)	1.94	135.99
EMEL2	EU-mix (medium voltage)	2.05	141.13
EMEL3	EU-mix (low voltage)	2.24	150.11
KOEL1	Coal (hard), conventional	1.81	292.37
KOEL2	Coal (hard), IGCC ¹	1.54	262.36
KOEL2C	Coal (hard), IGCC + CCS ²	1.98	71.04
GPEL1a	NG, pipe 7000 km, CCGT ³	1.35	144.98
GPEL1b	NG, pipe 4000 km, CCGT	1.19	132.43
GPEL1bC	NG, pipe 4000 km, CCGT, CCS	1.71	44.67
GREL1	LNG, CCGT	1.39	141.62
NUEL	Nuclear	2.40	0.39
WDEL	Wind	0.12	0.00
FIMIX	Electricity grid mix in Finland	1.43	32.8

1) Integrated Gasification and Combined Cycle, 2) CO₂ Capture and Storage, 3) Combined Cycle Gas Turbine

4.3.3 Simulation models and parameters

An electric city bus model was developed in the Autonomie vehicle simulation software.¹⁰² There are two different configurations for the electric bus: EV1 (opportunity charging), and EV2 (overnight charging). The EV1 configuration has a smaller power-type battery (capacity of 77 kWh) which is being charged during operation. The EV2 configuration has high-energy type battery with capacity of 373 kWh. The battery is charged overnight. These configurations were considered to be suitable for different types of operation. **Figure 47** shows the powertrain layout of the electric bus in the Autonomie simulation software.



Figure 47. Powertrain layout. First row: Battery, Electric motor, Reduction gear, Differential gear, Wheels, Chassis. Second row: Charging device, Power converter, Auxiliary devices.

The general specifications of the electric bus models are presented in **Table 6**. The models are based on a lightweight, full-size city bus. The theoretical maximum speed of the bus is 100 km/h. Two different powertrain configurations are described in **Table 7**. EV1 is configured for fast-charging operation and EV2 for overnight charging. The auxiliary power consumption was calculated based on the ambient temperature. The daily average temperatures of three different cities in Finland were used as a reference. The temperature data were downloaded from an open data source provided by The Finnish Meteorological Institute¹⁰³. The daily average temperatures shown in **Figure 48** are measured from different geographical places in Finland; cities of Helsinki (south), Lappeenranta (east) and Oulu (north).

¹⁰² Vijayagopal, R., Rousseau, A. System Analysis of Multiple Expert Tools, SAE Technical Paper 2011-01-0754, 2011, doi:10.4271/2011-01-0754.

¹⁰³ The Finnish Meteorological Institute, Open data, <https://en.ilmatieteenlaitos.fi/open-data> (accessed on 17-Feb-2016).

Table 6. General specifications.

Parameter	Value
Curb weight without batteries (kg)	9500
Gross vehicle weight (kg)	18 000
Vehicle frontal area (m ²)	7.24
Drag coefficient	0.79
Rolling resistance	0.008
Wheelbase (m)	6.5
Front weight fraction	0.34
Centre of gravity, height (m)	1.0

Table 7. Powertrain technical data and simulation parameters of the electric bus configurations.

Configuration	EV1 (opportunity)	EV2 (overnight)
Battery chemistry and capacity	Titanate Oxide, 60 Ah	Graphite/NMC, 200 Ah
Battery cell specific energy (Wh/kg)	80	160
Battery module configuration	10 cells in series	7 cells in series
Battery pack configuration	8 modules: 4 in series, 2 in parallel	6 modules: 2 in series, 3 in parallel
Battery system configuration	7 pack in series	12 pack in series
Battery system specific energy (Wh/kg)	60	120
Battery capacity (kWh)	77.3	373.0
Battery system weight (kg)	1295	3106
Motor nominal power (kW)	170	170
Motor max peak torque (Nm)	1710	1710
Gear reduction	1.75	1.75
Final drive ratio	4.72	4.72
Tires	275/70/22.5	275/70/22.5
Bus curb weight (kg)	10795	12606
Load capacity mass (kg) / persons	7205 / 96	5394 / 72
Charging efficiency	0.82	0.87
Battery depth of discharge	0.75	0.9
Operating hours in a year	4000	Cycle dependent

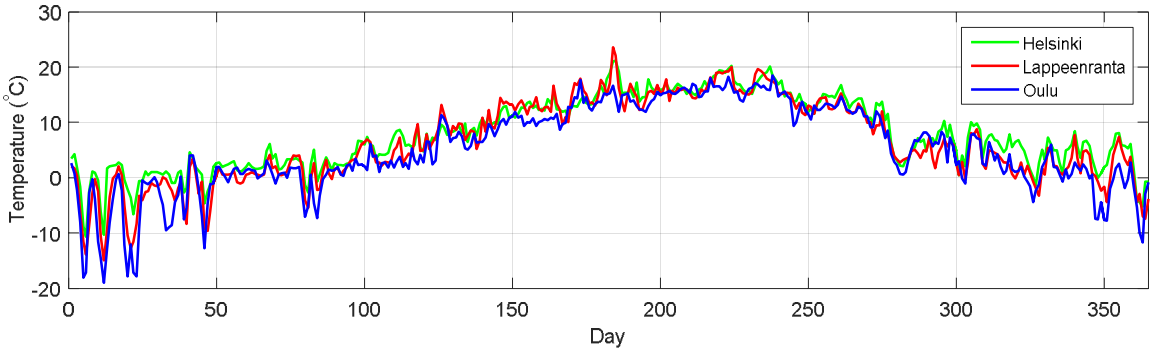

Figure 48. Daily average temperature of Helsinki, Lappeenranta and Oulu in 2015.¹⁰³

Figure 49A presents the estimated total auxiliary power consumption as a function of the ambient temperature, and **Figure 49B** shows the ambient temperature impact on energy consumption as a function of the average driving speed. The auxiliary power consumption in **Figure 49A** was estimated based on the recent literature.^{93, 100} The constant power consumption is 5 kW without the HVAC system. The total auxiliary power consumption based on the ambient temperature can be calculated using the estimated curve presented in **Figure 49A**. The reference simulations were carried out with 50% of the passenger load and in 15 °C of ambient temperature.

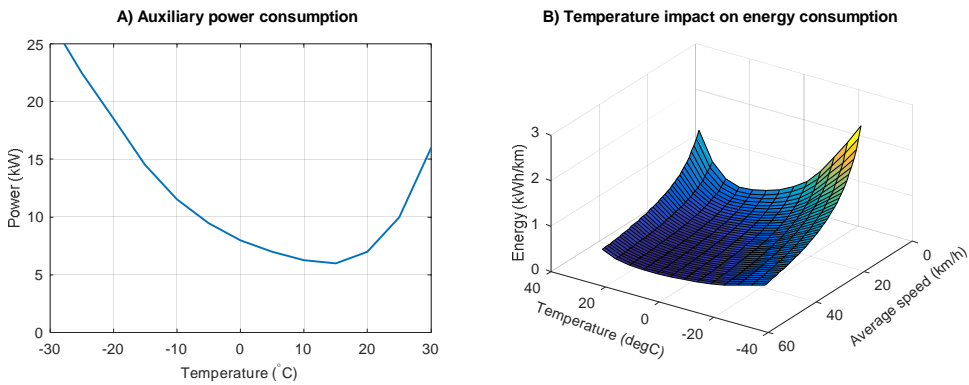

Figure 49. A) Estimated total auxiliary power consumption in function of ambient temperature. B) Temperature impact on energy consumption in function of the average driving speed.

Six different driving cycles were used in simulations. **Table 8** show the description of the cycles and **Figure 50** presents the speed and elevation profiles of the cycles. Espoo 11 (E11), H550 and route 51B (L51B) are measured cycles from existing bus operation routes and they also include elevation profiles. Braunschweig (BR) and

Manhattan (MAN) are commonly used test cycles for city buses. Helsinki (H3) is an extra-urban cycle that is intended to represent the operation on roads that are external to the urban environment. The number of buses in a fleet was calculated based on a 10-minute operating interval on the route.

Table 8. Description of the simulated driving cycles.

	BR	E11	H550	H3	L51B	MAN
Time (s)	1740	1548	3384	902	4283	1089
Distance (km)	10.9	10.2	28.7	10.3	16.1	3.3
Maximum speed (km/h)	58.2	58.4	74.9	71.7	59.0	40.5
Average total speed (km/h)	22.5	23.8	30.5	41.2	13.6	10.9
Average speed (km/h)	30.1	27.9	36.0	48.4	20.2	17.1
Stops per km	2.7	1.8	1.3	0.9	4.3	6.1
Aggressiveness (m/s ²)	0.235	0.152	0.206	0.195	0.281	0.306
Climbing gradient (m/km)	0.00	5.75	6.80	0.00	7.27	0.00
Descending gradient (m/km)	0.00	-5.83	-6.64	0.00	-7.26	0.00
Number of buses in a fleet	7	7	13	5	16	5

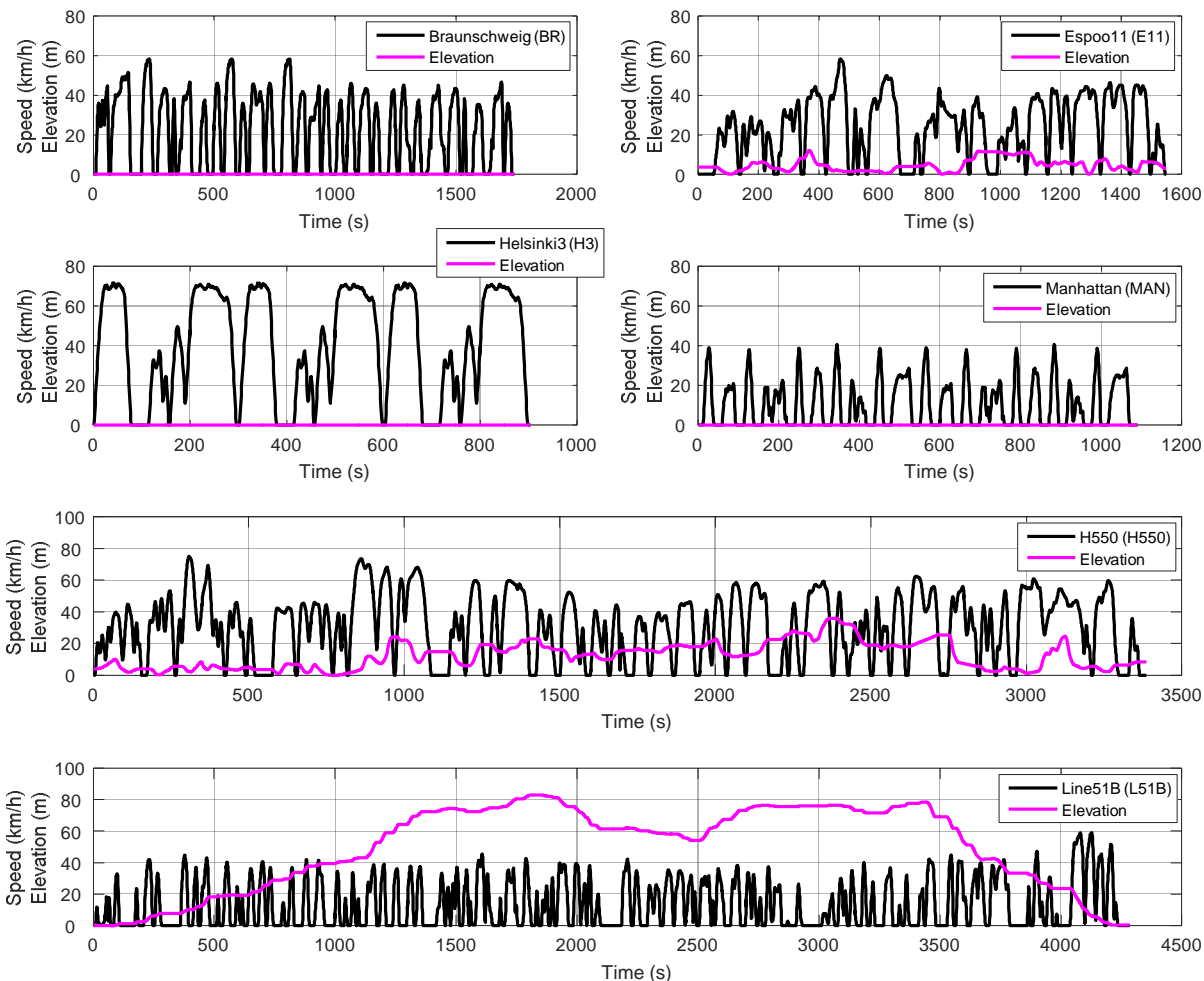

Figure 50. Speed and elevation profile of the simulated driving cycles.

4.3.4 Simulation results and analysis

The energy consumption of the electric buses was evaluated in different phases of the energy pathway. First, the electric bus consumption was analysed by calculating the component-specific losses based on the simulation results in different cycles. The reference simulations were done with 50% of passenger load and a constant power of 6 kW for auxiliary devices (including HVAC systems). **Figure 51** presents the distribution of powertrain losses for the EV1 bus configuration. The consumption variation between different cycles is about 0.5 kWh/km, which is quite significant; the increase in consumption between Espoo 11 and Manhattan cycles is more than

50%. The major part of the powertrain losses occurred in the tires, electric motor, and auxiliary devices.

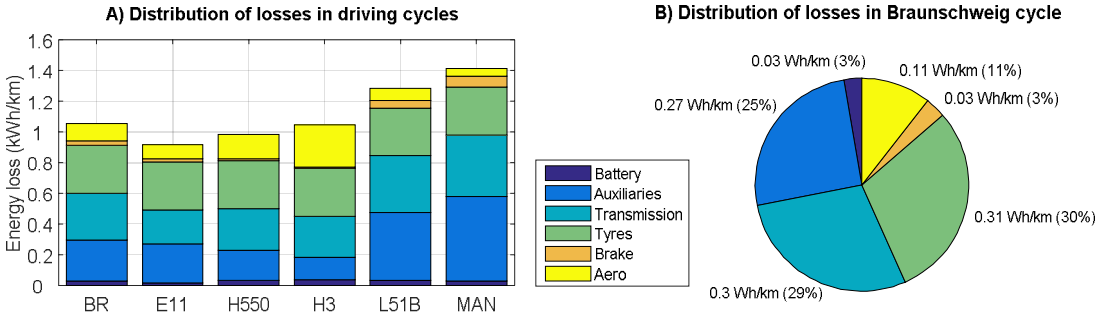

Figure 51. Distribution of powertrain losses for EV1 (opportunity charging).

Figure 52A shows the energy consumption for the EV2 bus configuration in two units: kilowatt-hours per kilometre and kilowatt-hours per hour of operation. It is important to analyse both of these units because it clarifies the differences between driving cycles. The energy consumption can be high for a distance (Manhattan) but it is not necessarily high for an hour of operation. This connects the energy consumption to the actual operation service, which is usually undertaken as service hours and not as a distance driven. **Figure 52B** presents the operating time and range for EV2 in each driving cycle. Because the EV1 configuration is charged during operation, e.g., at the end of the route, its service operation is not limited by the operating range. Similarly, to the results of the energy consumption, the operating time actually indicates the possible service hours in a given driving cycle for EV2 in **Figure 52B**. The operating range varies from 225 to 350 kilometres and hours of operation from 7 to 20 hours per day.

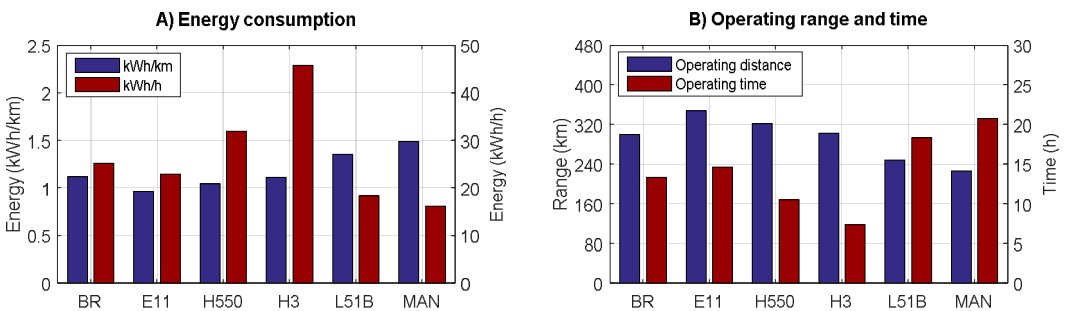

Figure 52. The reference energy consumption and operating range for EV2.

Figure 53 presents the passenger load impact on energy consumption as watt-hours per kilometre per tonne of passengers (Wh/km/tonne). In this case, one tonne (1000 kg) roughly equals 13 passengers. It can be seen that the load impact also depends on the driving cycle or more precisely on the driving style. In **Figure 53B**, it is shown that the energy consumption increase is actually more dependent on the type of driving than the driving cycle itself. More aggressive driving increases the impact of passenger load on the energy consumption. This can be explained by the fact that when driving aggressively, higher power levels (higher acceleration levels) are used in acceleration, which decreases the operating efficiency of the powertrain. In high deceleration levels, regenerative braking is limited due to the torque limitations of the electric motor.

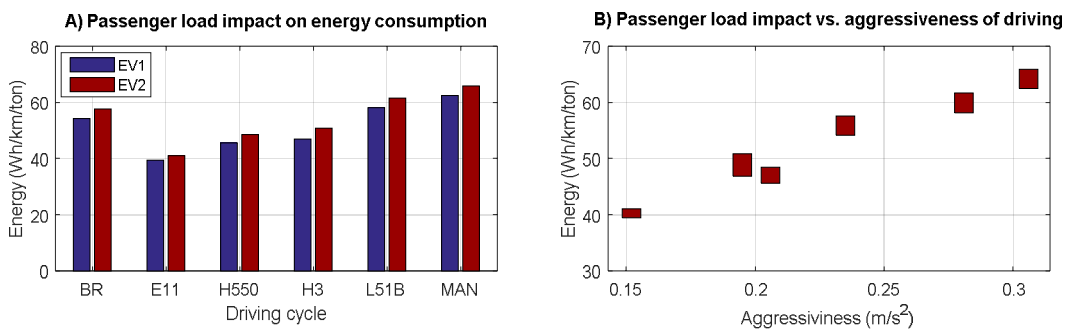

Figure 53. Passenger load impact on energy consumption.

Figure 54 presents the yearly average energy consumption, which was calculated based on the daily average ambient temperatures in Helsinki and Oulu (**Figure 48**). The red error bars show the daily consumption variation. On average, the energy consumption increase due to the ambient temperature changes was around 10% in comparison to the reference energy consumption (ambient temperature of 15 °C). It can be seen in **Figure 54** that there is only a slight difference in energy consumption between the bus configurations EV1 and EV2.

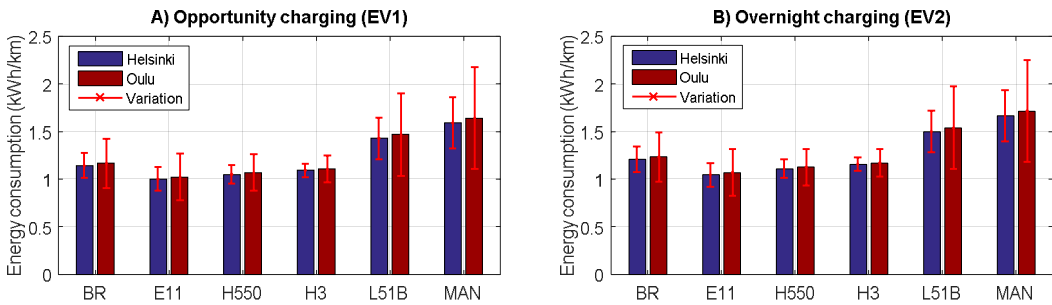

Figure 54. Yearly average energy consumption for EV1 and EV2.

The yearly consumed energy per one electric bus (EV1) and a fleet of buses is presented in **Figure 55**. The number of buses in the fleet was calculated based on the cycle time and operating interval of 10 minutes (**Table 8**). It can be seen that the energy consumed in higher speed cycles (H550 and H3) is much higher than the other type of driving cycles for an individual bus. **Figure 55B** shows the differences of consumed energy between driving cycles in fleet operation. The longer operating routes (H550 and L51B) have more buses in the fleet, which increases the amount of consumed energy.

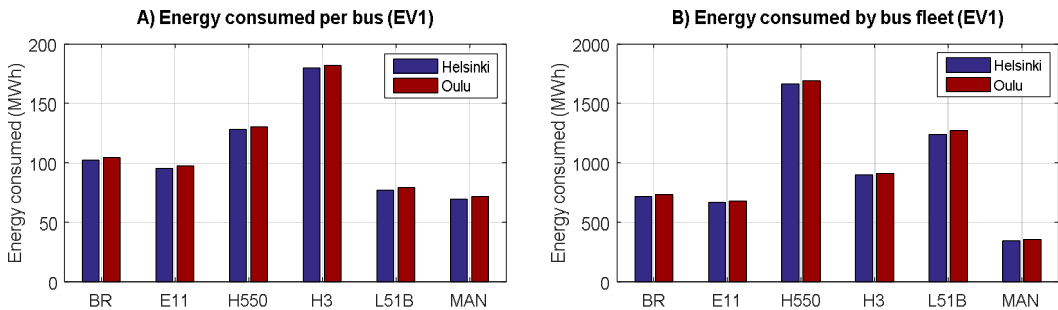

Figure 55. Bus and fleet specific yearly energy consumption.

When considering the total energy consumption of electric buses, the different phases of the energy use during the bus lifecycle are taken into account. The energy consumed in bus manufacturing, maintenance, material production and end-of-life (referred to as Bus) was calculated.⁸⁹ **Figure 56** shows the total energy consumption of one bus for EV1 in each driving cycle divided into four different phases: Bus, Well-to-Tank, Charging and Tank-to-Wheel. The different energy generation pathways were described in **Table 5** with corresponding energy consumption values.

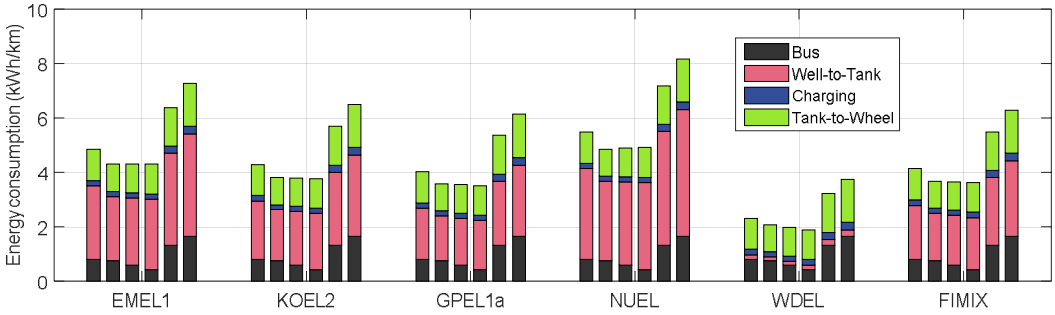

Figure 56. Total energy consumption distribution: different phases of the bus lifecycle (EV1).

With the exception of the wind energy pathway, all other electricity production pathways have a major share of the total energy consumption. On average, the bus manufacturing phase has slightly higher energy consumption than during bus operation (TTW). It should be noted that due to the different distances driven in each operating route during the service life, the share of the bus manufacturing phase varies between routes.

Carbon dioxide emissions were analysed for six different electricity generation pathways that were described in **Figure 46** and **Table 5**. The CO₂ emissions from bus manufacturing were calculated based on the values presented in the work of Garcia et al.⁸⁹ **Figure 57** presents the distance-specific CO₂ emissions for the different pathways and driving cycles. The Well-to-Wheel phase produces the major share of carbon dioxide emissions in the fossil-fuel-based electricity generation pathways EMEL1, KOEL2 and GPEL1a. Because the larger battery in EV2 increases the CO₂ emissions of the bus production and the operation range of EV2 is limited on routes BR, E11, H550 and H3, its distance-specific CO₂ emissions are slightly higher in comparison to EV1.

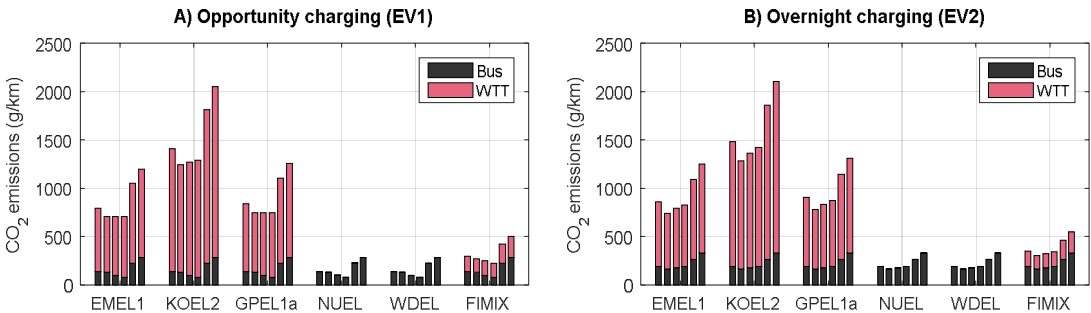

Figure 57. Carbon dioxide emissions from the bus manufacturing and electricity generation.

Figure 58 shows the total carbon dioxide emissions produced on a yearly basis for the different electricity generation pathways and driving cycles. **Figure 58A** presents the bus-specific CO₂ emissions and **Figure 58B** fleet-specific emissions. It can be seen that the differences are about same between the pathways as seen in **Figure 58**. The emissions are much higher in the longer routes (H550 and L51B) due to the size of the bus fleet.

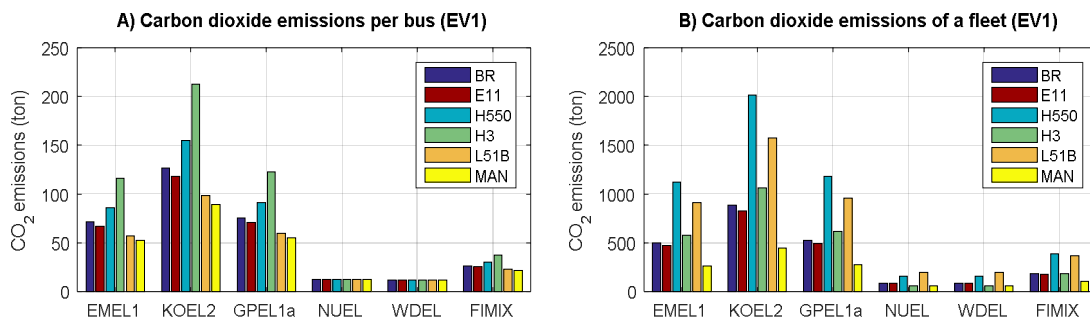

Figure 58. Yearly carbon dioxide emissions.

4.3.5 Conclusions

Electric city buses are considered to be a potential solution for energy efficient and emission-free public transport. Recent research studies have shown that electric buses have far superior energy efficiency than any other bus technology and they do not produce any emissions in operation. When analysing the global energy efficiency of electric buses, the primary energy sources of the electricity have to be taken into account. Especially in the case of carbon dioxide emissions, the energy pathway is crucial since there is no emissions produced in bus operation.

This paper presented an exhaustive analysis of the energy consumption of electric buses in the different phases of the lifecycle. It was shown that there are significant differences in distance-specific energy consumption between different operation routes. The evaluation of passenger load indicated that the driving style also has an important influence on energy consumption. The ambient temperature was taken into account in the calculation of the yearly average energy consumption. It was observed that, on average, the impact of the variation in ambient temperature (cities of Helsinki and Oulu in Finland) was around 10%.

The total energy consumed during operation depends on the operating route characteristics. In higher speed cycles, the yearly distance is higher, which leads to an overall higher amount of total energy per year. The differences between operating routes were observed in fleet operation. The energy consumed in the electricity production was higher for the fossil-fuel-based pathways, whereas it was very low for the wind energy pathway (WDEL).

The carbon dioxide emissions are heavily dependent on the electricity generation pathway. The CO₂ emissions during the Well-to-Wheel phase of the lifecycle are multiple times higher in the fossil-fuel-based pathways (European grid mix, coal and natural gas) than the CO₂ emissions due to the bus manufacturing.

4.3.6 Acknowledgements

The authors would like to acknowledge the technical and financial support from the ECV-eBus project, which is partly financed by the Finnish Funding Agency for Technology and Innovation (Tekes).

5. Electric commercial vehicle systems and charging

5.1 Fundamentals of eBus fast charging

Authors: Jukka Mäkinen, Daan Nap

Affiliations: ABB

Contact information for main author: jukka.a.makinen@fi.abb.com

Keywords: electric bus, battery, fast charging, CCS, opportunity, inverted pantograph, charging network services, depot charging

Abstract

In a world where environmental issues are increasingly important, more attention has been paid to ambient noise and NO_x & CO₂ emissions in transportation. It has been estimated that transportation alone causes 25% of the yearly NO_x & CO₂ emissions¹⁰⁴. The solution is to bring the traffic-related emissions down significantly for heavy electric vehicles, such as electric buses. Compared to traditional buses with ICE drivetrain, electric buses have no emissions, create almost no noise and use significantly less energy and have a higher efficiency than ICE counterparts (Internal Combustion Engines - diesel or gas). Even though eBuses alone will not solve emissions problems, they can have a profound impact on each country's oil-import dependence and even to some extent on the local manufacturing of heavy commercial vehicles with electric drivetrains – jobs in the vehicle industry. This article provides some information of the challenges associated with heavy electric vehicles - issues that are related to storing and charging the electricity needed for operation.

5.1.1 Defining the electric drivetrain

The on-board electrical energy storage is one of the key elements in all electric vehicles. The energy storage is typically a battery or super capacitor, or a combination of the two. The function of this energy storage is either energy buffer/source for hybrid vehicles, or the energy source of full electric vehicles. It is safe to say that lithium based batteries, such as LTO (Lithium Titanate Li₄Ti₅O₁₂), offer superior power performance when compared to any other commercially mature battery technology¹⁰⁵. The current declining costs of lithium-ion batteries is expected to continue due to the fact that more and more research is contributing to improved efficiency and cutting down production costs, as well as through rising battery production volumes.

¹⁰⁴ The Lithium Revolution (2012). Retrieved from: http://www.polarstarfilms.com/en/d_the-lithium-revolution.php & <http://areena.yle.fi/1-1955169>.

¹⁰⁵ Lajunen, A. Improving the Energy Efficiency and Operating Performance of Heavy Vehicles by Powertrain Electrification. Doctoral Dissertation. Aalto University, 2014.

The power consumption profile on electric commercial vehicle varies according to application – city tractors, road maintenance vehicles, short distance delivery vehicles as well as on buses. Each features an inherent need for high peak performance, in acceleration peak loads and recuperating energy on deceleration. The sizing of the whole drivetrain from the battery, through the converter and drive motor as well as the charging network topology is a new type of challenge, therefore teamwork with experienced partners is a must. A typical concept for Europe is shown in **Figure 59**.



Figure 59. An electric bus with fast opportunity charging interface.

5.1.2 Comparing different battery and charging topologies

On-board energy storage needs to be frequently charged to keep vehicles on the road. Within the past five years, several types of fast charging methods have been piloted across the globe. With respect to on-board battery size – two possibilities are available – either very large or an optimised small size. Depending on selected on-board energy storage approach and size, the charging method is either slow or fast. With the large battery pack approach, achieving full charge using overnight (slow) charging takes several hours and is typically based on manual connection/disconnection of the charging cable via a plug.

When an optimised battery pack is deployed, charging is based on so-called opportunity charging, where charging stations are fully automated and located along the route and charging takes place according to specific opportunity. The number of wayside charging stations needs to be optimised in terms of their power and strategic location. When the electric bus itself is fragmented into a list of components, the battery size is a key factor in the pricing of the bus. A large battery pack increases the total costs of the purchase as well as the total cost of ownership (TCO).

A vehicle fleet with large batteries and overnight charging as a concept is less energy efficient, its TCO is more dependent on battery chemistry and has a lower driving range in the long run. Furthermore, slow charging of a massive bus fleet also requires a substantial amount of overnight charging power at the bus depot. A larger battery pack also reduces the maximum passenger capacity of the bus, due to its physical size & weight. Every 65 kg of battery weight is one passenger less on the bus. Therefore, an optimised battery pack size and fast charging are becoming increasingly popular technology solutions. In addition, electric bus battery packs and charging standardisation development has followed the Combined Charging System (CCS), which has already been selected by the major European & US carmakers for electric personal vehicles.

During the active part of the day, from 5 a.m. to 11 p.m., the bus fleet must be operational with the maximum driving hours. That is one of the reasons why plug charging during the day is less beneficial than automated opportunity charging. In automated fast charging, there are two alternative topologies, en-route charging, which takes approx. 15 seconds and is located at every 3rd or 4th bus stop, or charging at the end-stop of each bus route. En-route charging requires a dense network of high power charging stations with energy buffers (super capacitors), has not yet been standardised, and is most useful for longer buses. En-route charging also demands more physical space at the bus stops, and as there is a limited timeframe for charging, it fits best on densely operated routes¹⁰⁶.

End-stop charging typically requires only two charging stations per route, located along the route or by the return point of the route, using smaller energy buffers. Therefore, it is much easier to implement into the existing route network. End-stop charging also continues the existing breaks for the driver and provides some recovery buffer in case the bus is running late during traffic peaks. SoC (State of Charge) of an electric bus using an end-stop fast charging station is filled up to 80% during the active part of the day, **Figure 60**.

¹⁰⁶ Augé, O. Taking charge, ABB Review, 4, 64–69, 2013.

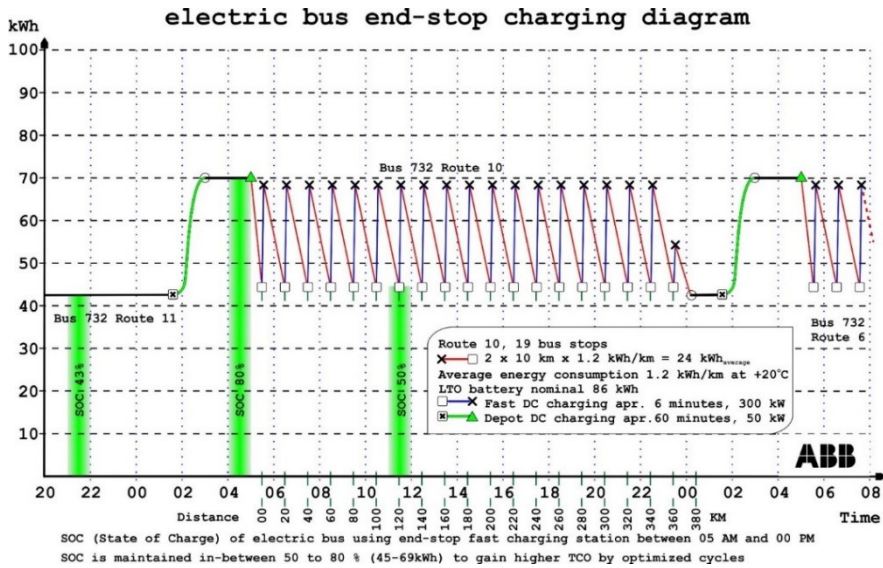

Figure 60. Graphical illustration of end-stop charging – BMS and end-stop fast charging station keeps the SoC within a 50-80% threshold to gain improved TCO.

The actual fast charging station may also relocate the end-stop to be in-between existing end-stops for charging only if the electric grid connection is more practical e.g. by the city centre than by the traditional end stops. As an average, the supply cabling (20 kV) required for a new compact secondary substation for a new end-stop charging station may cost approximately 35–40 k€ per each kilometre.

Fundamentally, there are two types of principles when using end-stop fast charging to support the transfer of energy to the battery pack. Power is conducted by means of a so-called pantograph that is either located on the rooftop of the bus or attached to the charging poles at the charging stations. In the case of an on-board set-up, the appropriate profile is located by the station. The other case scenario that is becoming increasingly popular is an inverted pantograph employed by means of a charging pole. One clear advantage of the inverted pantograph is that it significantly lowers the cost and weight of a bus. Inverted pantographs offer maximum safety as they operate far above the ground level and are powered only when the vehicle is present. All the moving elements are integrated in the charging pole. The bus only has fixed connectors.¹⁰⁷

5.1.3 Results – powering at the end-stop

One of the fundamental elements of providing reliable fast charging for electric personal vehicles has been the electro-mechanical design of the power electronics of

¹⁰⁷ Volvo 7900 Electric Hybrid brochure. 2014.

the charging stations. Practical expertise in the design and installation of four product generations and over 2000 eV charging stations (for personal cars) has been the baseline for heavy duty end-stop charging stations (ABB Heavy Vehicle Charging - HVC) for electric buses. It is safe to say that selecting the HVC type of fast charging stations for the end-stop charging ensures the highest up-time on the market. Based on the fact that the CCS standard will be adopted for automated fast charging, it is most recommendable that depot charging adopts the same standard. ABB's Terra depot charging is cluster-controlled and uses an ABB optimising algorithm to keep depot charging load within a defined threshold, ensuring the lowest costs for grid connection and maximum serviceability in the early hours of the day e.g. between 02:00–04:00. Identical benefits to eV charging are offered through connected services with the added value of real-time monitoring with a shared knowledge database of operational issues that can assist in any circumstances. An optional assisting power tool – the Driver Care – is a web-connected service that ensures the highest uptime. In this type of service platform, each station is 3G connected into the ABB's cloud service and through a browser screen each Electro Mobility Operator (EMO) has full access to their own charging network at a more detailed level than on Open Charge Point Protocol (OCPP), which defines the communication between the vehicle and the charger. Each event can be monitored in real-time as well as logged such that it can be browsed later to follow up historical data. One of the key elements gaining the highest reliability is the local database on each HVC station. Sometimes a communication network is overloaded and each HVC station is able to continue charging operations, if each of the vehicles using the station are added to the white list by the operator. In a transition plan from ICE to electric driven buses, the following issues should be taken into account with respect to each end-stop charging station: its location may depend on electric network (sufficient power), maximum up-time can be achieved when all commercial electric vehicles (strategic location – serving multiple types of vehicles) can utilise charging network, road network needs to provide sufficient operational space for large vehicles.

The automated fast charging solution typically adopts the following structure, **Figure 61**:

- Optional CSS (Compact Secondary Substation) 20/0.4 kV
- HVC wayside DC station 150–450 kW
- HVC pole with inverted pantograph
- Load controlled clustered depot charging HVC CCS 50 kW
- Driver Care connected service
- Service Level Agreement

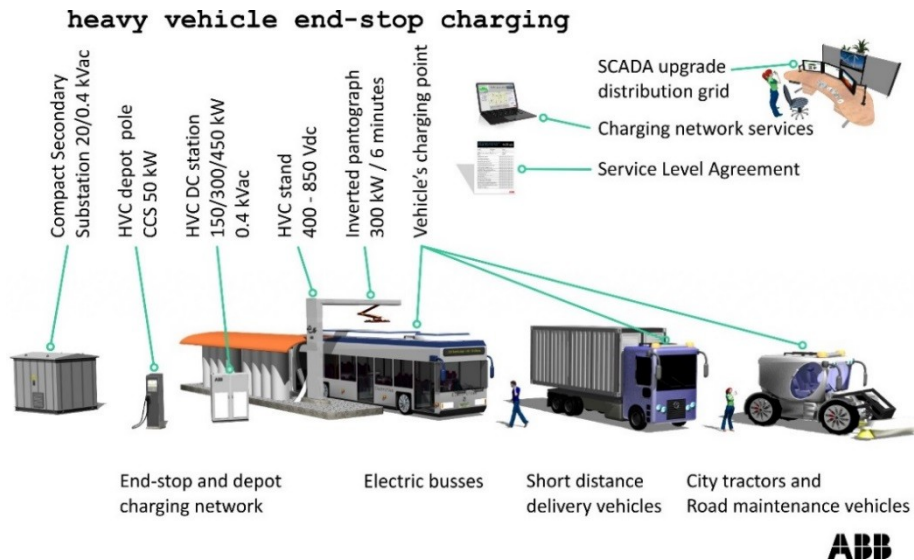

Figure 61. A single HVC end-stop fast charging station that powers all types of heavy electric vehicles increase charging network's ROI. Vehicles can be charged at end-stops in between eBus charging session, when the station is free. Furthermore, a higher ROI is achieved since charging sessions for short distance delivery vehicles are scheduled between 11 pm to 5 am – at low peak hours.

5.1.4 End-stop charging is a winning solution

Heavy electric vehicles and their charging network are expected to bring many potential benefits in the future. On the larger scale, the electric vehicles reduce each country's oil imports, offer higher operational efficiency and reduce total costs of ownership of the vehicle fleet and charging infrastructure. These crucial economic benefits favour electricity in transportation together with reduced NO_x & CO₂-emissions and reduction in the ambient noise levels. The expected TCO values for eBus solutions with longer lifetimes (12–15 years) are more competitive than on ICE-based vehicles as battery technology becomes even cheaper¹⁰⁸. A bus fleet that supports end-stop charging furnished with inverted pantograph has the following advantages:

- high energy efficiency
- low costs of the bus
- high passenger capacity
- low infrastructure installation costs
- low initial impact on city traffic
- high flexibility and long range

¹⁰⁸ Grauers, A. Method to Analyse Cost Effectiveness of Different Charging Systems for Electric Buses, Nordic Electric Bus Initiatives, Göteborg, p. 10–11, 2015.

In addition, automatic opportunity charging is also easy to use for the bus drivers. Although there are a lot of optional technologies available for fast charging, it can be forecasted that inverted pantograph will be the dominant technology for transferring power from the grid to the electric buses.

5.1.5 Conclusions

The use of inverted pantograph ensures the maximal safety and minimises delays. In order to ensure maximum up-time of the charging network, the telemetry information of each station can be followed and controlled by means of connected services. The built-in local database on each one of the stations provides extra redundancy as they can continue charging services even if the communication network is occasionally down. End-stop fast charging and CCS depot charging are the choice of the major players within public transportation business. With expertise of over two thousand installed charging stations, ABB's new HVC stations offer superior performance and top-of-the-line innovations to charge up the bus fleet at end-stops. The most advanced and reliable design can be achieved by selecting end-stops charging DC stations with improved redundancy.

In the design of the charging network, there are four main points to consider.

- Existing electric network may define available installation locations
- The existing city and bus operator demands versus capacity, timing & routes
- How to achieve maximal up-time for all commercial vehicles, not just electric buses
- Whether the installation location has the adequate available space for larger vehicles

A scenario for the near future sees the adoption of electric buses with an optimised small size battery pack and fully automated end-stop fast charging. In this scenario, the charging network would not only serve the eBuses but also other heavy commercial vehicles. In a larger context, electrified traffic in multiple applications offers increased state incomes where substantial potential is available if the production of electric commercial vehicles for road traffic is done domestically. The path to that future begins today.

5.2 Feasibility of electric buses in public transport

Authors: Olli Vilppo, Joni Markkula

Affiliations: Department of Electrical Engineering, Tampere University of Technology

Current contact information for main author: olli.vilppo@ineteres.fi

Abstract

This study examines the economic feasibility of electric buses in a mid-sized city, where public transport is currently organised with buses only. The difference in lifetime cost of electric buses and diesel buses was calculated with the chosen parameters selected after a careful background analysis. A viable business case can be created when the battery and the charging infrastructure are selected shrewdly. The electricity is much cheaper fuel than diesel but with the current battery technologies and battery prices, the significant cost from operating an eBus comes from the wear of the battery. Two types of Li-ion batteries were compared, LFP (Lithium Iron Phosphate) and LTO (Lithium Titanate). In addition, different conductive opportunity charging strategies were examined: 1. Charging at the depot. 2. Charging at the end stop(s). 3. Charging at the line stops.

The round trip line length assessed was 20 km. Calculations show that the LTO buses and a fast charger at the end stop complemented with low power overnight chargers at the depot is the best investment combination based on the given assumptions. The 200 kW charging power is sufficient to ensure the charging in the normal end stop breaks. Due to a longer cycle life, the wear cost per km was lower for LTO than for LFP. LTO is also better adapted for fast charging. The battery size has to be sufficient compared to the required driving range during peak consumption, to the charging current and to the performance requirements of the eBus. Oversizing the battery has some positive effects (improved cycle life, less heating and better flexibility) but the negative effects were estimated to be more significant (higher investment cost, increased weight and space requirement).

5.2.1 Introduction

The most critical component of an electric vehicle is the battery. A battery is an energy storage device that stores electrical energy in chemical bonds. There are different types of batteries used in transportation, but especially the development of the Li-ion batteries has furthered battery electric vehicles (BEV). One of the major challenges with wider BEV adoption is the lack of sufficient charging infrastructure. This challenge can be tackled more easily when electrifying city buses than with passenger electric cars. City buses utilise the same routes, they spend the nights in the same depot and also the driving times are fixed. Locations of the chargers and utilisation times can be optimised and bus routes can be electrified one by one. The electric bus industry is currently in a prototype phase although the industry holds a lot of potential.

This article presents a case study of the current economic feasibility of electrifying one whole city route compared to operating the route with diesel buses. Besides potential monetary savings, electric buses have environmental advantages over diesel buses. They reduce pollution and the noise level in the city. EBuses can improve the city image considerably.

5.2.2 Experimental / methodology

Our case study examined the feasibility of electric buses in the Tampere city public transport with a focus on the economic feasibility. Tampere is a city of 220 000 people and currently public transportation is organised only by means of buses. The city's own public bus operator serves the majority of the routes within the city area. Some routes are served by private bus-operators. In Tampere city, the buses usually drive through the slow city centre and have end stops in different residential districts of the city. The other end stop is in some cases located in the city centre. For the first city route to be electrified, one route with round trip length of 20 km and an average speed of 20 km/h was examined.

The financial calculations were made by comparing costs between the electric buses and diesel buses. Only those costs that are different between bus types are considered in the analyses. The costs included in the analyses are the investment cost of the buses, fuel or energy cost, and the maintenance cost. For electric buses, there are also the battery replacement cost and the investment cost for the charging infrastructure and its maintenance cost.

The costs excluded from the analyses that do not differ between bus types include driver wage, depot-related costs, insurance, and vehicle inspection costs. The more accurate description of how the parameters were selected and different charging strategies examined have been reported previously.¹⁰⁹

Table 9. The electric bus parameters.

Bus type	LTO 42 kWh	LFP 200 kWh
Price of the bus	384 000 €* 384 000 €	480 000 €
Grid electricity consumption	1.1 kWh/km	1.18 kWh/km
Vehicle consumption	1.0 kWh/km	1.07 kWh/km
Maintenance cost	0.22 €/km	
Auxiliary diesel heater cost	1000 €/year	

*Includes the first battery and pantograph and contact dome on the bus 20 000 €

¹⁰⁹ Markkula, V. Feasibility of electric buses in public transport, International Electric Vehicle Symposium and Exhibition (EVS28), May 2015, pp. 1–9.

Table 10. The diesel bus parameters.

Bus type	Diesel
Price of the bus	250 000 €
Vehicle consumption	0.4 l/km
The maintenance cost	0.25 €/km

Table 11. The average fuel costs next 12 years.

Grid fee (VAT 0%)	0.041 €/kWh
Electricity price (VAT 0%)	0.038 €/kWh
Diesel price (VAT 0%)	1.2 €/l

Table 12. Charging infrastructure costs.

Depot charger per bus	5 000 €
One automatic 200 kW fast charger	200 000 €
Maintenance of depot charger	250 €/pc/year
Maintenance of the fast charger	3000 €/year

5.2.3 Results

The most economical charging strategy was end-stop charging. The cash flow analysis of the costs was performed for the end-stop charged LTO bus route (**Table 13**), end stop charged LFP bus route (**Table 14**) and for diesel bus route (**Table 15**) with the discount rate of 3%. First-year costs include the investment cost of buses and the charging infrastructure cost for the electric buses. The maintenance and fuel or energy costs are incurred every year. The LTO bus battery change takes place after 6.5 years. By comparing the Net Present Values (NPV), it can be seen that the LTO bus route (NPV of costs 2.9 M€) saves money in a 12-year period compared to the diesel bus route (NPV of costs 3.1 M€). The cost of LFP bus route (NPV of costs 3.1 M€) is at the level of the diesel buses, but only if battery replacement is not needed because of low DoD.

Table 13. Cash flow of the costs with end stop charging and operating with 4 buses with 42 kWh LTO batteries (numbers in 1000 €)

Year	2015	2016	2017	2018	2019	2020	2021	2022	2023	2024	2025	2026
Buses	1629	91	91	91	91	91	309	91	91	91	91	91
Infra	224	4	4	4	4	4	4	4	4	4	4	4
NPV	2911											

Table 14. Cash flow of the costs of end stop charging and operating with 4 buses with 200 kWh LFP battery in the event that battery change is not needed, because of low DoD (numbers in 1000 €)

Year	2015	2016	2017	2018	2019	2020	2021	2022	2023	2024	2025	2026
Buses	2011	92	92	92	92	92	92	92	92	92	92	92
Infra	224	4	4	4	4	4	4	4	4	4	4	4
NPV	3121											

Table 15. Cash flow of the costs of operating the route with 4 diesel buses (numbers in 1000 €)

Year	2015	2016	2017	2018	2019	2020	2021	2022	2023	2024	2025	2026
Buses	1204	204	204	204	204	204	204	204	204	204	204	204
NPV	3095											

5.2.4 Discussion

The costs of the charging stations were rough estimations. Prices vary greatly and should be checked from the manufacturer. It is recommended to prefer the open protocol systems to avoid the lock in to one manufacturer.

The cost for building and strengthening the electric grid are highly dependent on the present conditions of the city grid. Different government incentives might be available to lower the charging infrastructure cost for the city. The diesel price level affects the calculations considerably and since the calculations were initially done in the summer of 2014, the diesel market price has declined according to the crude oil market price. Still, the average price of 1.2 €/l (VAT 0%) seems like a reasonable estimate for the next 12-year period. At the same time, battery prices have decreased faster than expected.

In the calculations, end stop fast charging was assumed to be available 100% of the time. Inoperative fast charging is a large cost driver, as the small battery buses cannot be operated during their downtime. In case the charging fails, it is important that the bus has enough energy left to drive back to the depot. In that way, at least the towing expenses can be avoided.

5.2.5 Conclusions

The LTO buses and a fast charger at the end stop, complemented with low power overnight chargers at the depot, is the best investment combination based on the given assumptions. The end-stop charging offers the best way to reduce the battery size at reasonable infrastructure cost. The reason for supporting the LTO selection is the lowest battery wear cost per km. This is due to a superior cycle life.

The low energy consumption of an eBus is important as it affects not only the energy cost but also the battery wear cost and the time required for charging. Electric bus industry is currently in the prototype phase and the buses and batteries are likely to improve and their prices to lower in the future. Also, the same phenomena can be expected from fast chargers. Already the present technology is capable of creating savings, when compared to traditional diesel buses, when the total cost of ownership is calculated. To be successful, eBus project requires careful planning and interplay of different parties (city, operator, grid owner and manufacturers). Electric bus adoption is encouraged by the authors.

5.3 Lifecycle cost evaluation of electric bus operation

Authors: Antti Lajunen

Affiliations: Aalto University

Current contact information for main author: antti.lajunen@helsinki.fi

Abstract

This paper presents a lifecycle cost evaluation for battery electric buses. A dedicated simulation environment was developed to investigate the technical requirements and lifecycle costs of electric bus operation. Simulations were carried out in two measured operating routes, which correspond to existing bus routes in Finland. The simulation model was parameterised on the basis of a prototype bus that was developed in the research project ECV-eBus. The results of the lifecycle cost evaluation show that the charging devices and purchase costs of electric buses represent the major part of total costs. The charging infrastructure costs depend on the characteristics of the operating route and charging method. In comparison to a traditional diesel bus, the lifecycle costs of electric bus operation with the end station charging are only slightly higher with the present cost level. The opportunity charging increases the lifecycle costs significantly if the charging stations cannot be shared with multiple bus routes.

5.3.1 Introduction

Battery electric city buses have been rapidly developed in recent years^{110,111} and they are getting more cost-effective every year.^{112,113} There are several different manufacturers in the markets, and also the traditional city bus manufacturers are interested in developing them. There are several different operating methods for electric buses due to the different options in charging methods¹¹⁴. The battery can be charged overnight at the depot, it can be charged during operation at end stations, or along the route at dedicated bus stops. In-route charging is often called opportunity charging, which has been demonstrated e.g. in TOSA project in Geneva¹¹⁵. Battery swapping has sometimes been considered instead of charging but it requires a substantial investment in a battery swapping station¹¹⁶. Further, a research and demonstration project has been carried out for wireless charging^{117,118}.

The recent technological development of lithium-based batteries has made them the best choice for energy storage for electric city buses. The high energy type lithium-based batteries have good specific energy (energy capacity to weight ratio), which enables even full-day operation without recharging the battery during operation. However, the required battery capacity is high, which increases the total weight and purchase costs. The high-power type batteries have good power-to-weight ratio and thus good specific power. These types of batteries are used when using a fast-charging method to charge the batteries.

In this research, the lifecycle costs were evaluated for battery electric city buses with fast charging. Two different fast-charging methods were analysed: end-station charging and opportunity charging. A dedicated simulation environment was developed in MATLAB to thoroughly investigate the technical requirements and lifecycle costs of electric buses in different types of operation. The research results show an

¹¹⁰ Choi, U.-D., Jeong, H.-K., Jeong, S.-K. Commercial Operation of Ultra Low Floor Electric Bus for Seoul City Route, in Proc. IEEE Veh. Power Propulsion Conf., Sep. 2012, pp. 1–6.

¹¹¹ Festner, L., Karbowski, G. Foothill Transit Ecoliner Electric Bus Program, in Proc. 26th World Battery, Hybrid Fuel Cell Elect. Veh. Symp. Exhib., May 2012, pp. 1–8.

¹¹² Lajunen, A. Energy consumption and cost-benefit analysis of hybrid and electric city buses, Int. J. Transportation Research: Part C, **38**, 1–15, Jan. 2014.

¹¹³ Pihlatie, M., Kukkonen, S., Halmeaho, T., Karvonen, V., Nylund, N.-O. Fully electric city buses – The viable option, in Proc. 2014 IEEE International Electric Vehicle Conference (IEVC), Dec. 2014, pp. 1–8.

¹¹⁴ Göhlich, D., Kunith, A., Ly, T. Technology assessment of an electric urban bus system for Berlin, Urban Transport XX, 2014, pp. 137–149.

¹¹⁵ Ahmed, S., Hongrae, K., Prohaska, T., Ronkainen, T., Burgos, R. Stability Study of Electric Vehicle Power Electronics Based Power System, in Proc. 2013 IEEE International Electric Vehicle Conference (IEVC), Oct. 2013, pp. 1–5.

¹¹⁶ Dai, Q., Cai, T., Duan, S., Zhao, F. Stochastic Modeling and Forecasting of Load Demand for Electric Bus Battery-Swap Station, IEEE Transactions on Power Delivery, **29**(4), 1909–1917, Aug. 2014.

¹¹⁷ Bailey, J.R., McBath, J., Hairr, M.E. Increasing the Range of Electric Shuttle Buses with Wireless Charging, in Proc. Electric Vehicle Symposium, May 2012, pp. 1–15.

¹¹⁸ Miles, J., Potter, S. Developing a viable electric bus service: The Milton Keynes demonstration project, Research in Transportation Economics, **48**, 357–363, Dec. 2014.

evaluation of the lifecycle costs including a breakdown analysis of different cost areas.

5.3.2 Research method

The energy consumption of the electric bus in its operating route is the key factor for dimensioning the energy storage of the bus, and for defining the design requirements for the charging technology. As there are several different solutions for energy storages and charging technology, it requires a multi-variable analysis to reach to a desired solution, as was demonstrated in previous research.¹¹⁹ Because on-board energy storages such as batteries are still relatively expensive, the energy storage is usually dimensioned in such a way that the electric bus would be as competitive as possible economically. The charging equipment represents an important economic and infrastructural investment for a relatively long period of time. Therefore, the chosen charging solution is typically foreseen to last longer than the typical service life of electric buses.

Vehicle simulation is a practical and efficient way to evaluate the energy consumption and technical requirements of electric buses on any kind of operating route and in any conditions. In the ECV-eBus research project, a simulation model of the prototype electric bus was developed.^{120,121} The model was verified with the dynamometer measurement results.¹²² The developed simulation model was used in this research to define the energy consumption on different operating routes. **Figure 62** presents the prototype electric bus that was developed in the ECV-eBus project. Two measured bus operating routes were defined for simulations; Espoo 11 and H550. The Espoo 11 (E11) route corresponds to Espoo the region bus route in Finland in which commercial electric buses and the prototype electric bus have been tested. The route H550 is a measured driving cycle, which corresponds to a bus route in Helsinki region.

¹¹⁹ Rogge, M., Wolny, S., Sauer, D.-U. Fast Charging Battery Buses for the Electrification of Urban Public Transport—A Feasibility Study Focusing on Charging Infrastructure and Energy Storage Requirements, *Energies*, **8**(5), 4587–4606, May 2015.

¹²⁰ Lajunen, A. Powertrain Design Alternatives for Electric City Bus, in Proc. IEEE Veh. Power Propulsion Conf., Oct. 2012, pp. 1–6.

¹²¹ Lajunen, A. Comparison of Different Powertrain Configurations for Electric City Bus, in Proc. IEEE Veh. Power Propulsion Conf., Oct. 2014, pp. 1–5.

¹²² Laurikko, J., Nylund, N.-O., Pihlatie, M., Halmeaho, T., Kukkonen, S., Lehtinen, A., Karvonen, V., Mäkinen, R., Ahtiainen, A. Electric city bus and infrastructure demonstration environment in Espoo, Finland, in Proc. International Electric Vehicle Symposium and Exhibition (EVS28), May 2015, pp. 1–11.



Figure 62. Prototype electric bus developed in ECV-eBus project.

5.3.3 Lifecycle cost calculation

There are three main cost areas in the lifecycle costs for electric city buses; capital costs (C_{CAP}), operation costs (C_{OP}), and technology replacement costs (C_{REP}). Equation 12 describes the annualised lifecycle cost calculation

$$C_{LC} = C_{CAP} + (C_{OP} + C_{REP}) \cdot (1 + d_{rate})^{-j} \quad (12)$$

The capital costs include the purchase costs of the buses and the costs of the charging devices. d_{rate} is the discount rate. The calculation of the capital costs is defined in Equation 13.

$$C_{CAP} = N_{bus}C_{bus} + C_{chg} + C_{chg}M_{chg} \cdot (1 + d_{rate})^{-j} \quad (13)$$

N_{bus} is the number of buses in a fleet, C_{bus} is the purchase costs of a bus, C_{chg} is the costs of the charging devices, and M_{chg} is the yearly costs of the charging device maintenance as a percentage of the initial purchase costs. The bus operation costs include energy, maintenance and carbon dioxide (CO_2) emission costs. Equation 14 shows the calculation of annualised operation costs.

$$C_{OP} = \sum_{j=0}^T (N_{bus}D_j(C_{nrj_j} + C_{m_j} + C_{co2_j})). \quad (14)$$

D_j is the yearly driven distance, C_{nrj_j} is the energy cost per driven distance, C_{m_j} is the maintenance cost per driven distance, and C_{co2_j} is the CO_2 emission costs. The technology replacement costs refer to the necessary replacement of energy storages, in this case batteries. The calculation of annualised technology replacement costs is depicted in Equation 15.

$$C_{REP} = \sum_{j=0}^T (N_{bus}C_{tech_j}), \quad (15)$$

where $C_{tech,j}$ is the yearly technology replacement costs. The useful life of the batteries was defined based on the estimations presented in the literature. **Table 16** describes the cost parameters for a typical diesel bus and electric bus. The maintenance costs of the electric buses are considered the same as in diesel buses. The operating time of buses was 4000 hours in a year. The service life of the buses was assumed to be 12 years, which could be higher especially for electric buses. The discount rate was 4%. In this study, the charging devices are assumed to be used only on one operating route although it is possible that charging devices are shared by multiple operating routes.

Table 16. Lifecycle cost parameters.

Cost parameter	Diesel bus	Electric bus
Purchase costs (€)	225 000	350 000 (without battery)
High power battery cost (€/kWh)	---	800
High power battery cycle life	---	5000 cycles
Maintenance costs (€/km)	0.16	0.16
Fast charging device costs (€/unit)	---	250000
Charging device maintenance costs (%)	---	3
Energy costs	Diesel: 1.0 €/l (without VAT)	Electricity: 0.10 €/kWh

5.3.4 Vehicle and operating data

The configuration data of the electric bus are presented in **Table 17**. The electric bus model corresponds to a lightweight, full-size (12 metres long) city bus with a fast charging capability. **Table 18** shows the powertrain specifications including battery and electric motor data. Simulations were done with four energy capacities of the battery system, from 60 kWh to 120 kWh. The reference battery system (**Table 18**) has 6 battery packs in series.

Table 17. Technical specifications of the electric bus.

Curb weight (kg)	9500
Gross weight (kg)	15000
Vehicle frontal area (m ²)	6.2
Drag coefficient	0.7
Rolling resistance coefficient	0.008
Rolling radius (m)	0.412
Wheel inertia (kgm ²)	14.5
Final drive ratio	4.88
Tires	285/70/19.5
Load capacity (kg) / persons	5500 / 70

Table 18. Technical specifications of the powertrain.

Battery chemistry and capacity	LTO, 30 Ah
Battery cell specific energy (Wh/kg)	80
Battery module configuration	10 cell in series
Battery pack configuration	15 modules: 5s3p
Battery capacity (kWh)	60
Battery system weight (kg)	1000
Motor nominal power (kW)	207
Motor nominal torque (Nm)	1100
Battery efficiency in charging	0.97
Charging device efficiency	0.90

Simulations were carried out in two driving cycles that had previously been measured from existing bus operating routes in Helsinki and Espoo. Both routes are round trips; the descriptions of the operating routes are shown in **Table 19**. The speed and elevation profiles are presented in **Figure 63**. With end station charging, the charging of the battery is done at the start point and midpoint of the round trip. The reference power limit of the end station charging was assumed to be 300 kW, which results in minimum charging times of 3 minutes for the Espoo 11 (E11R) and 6 minutes for the H550 route (H550R). The amount of charging stops for opportunity charging were calculated based on 400 kW maximum power and 30 seconds average charging time at the stop. The H550 route requires 16 charging points and the Espoo 11 route six charging points along the round trip route.

Table 19. Description of the operating route round trips.

Cycle name	Espoo 11 R		H550R (Jokeri)	
	Tapiola - Friisilä	Friisilä - Tapiola	Itäkeskus - Westend	Westend - Itäkeskus
Time (s)	1800	1674	3305	3437
Distance (km)	9.3	8.8	28.6	28.8
Maximum speed (km/h)	52.0	52.6	80.0	74.9
Average total speed (km/h)	18.7	18.8	31.1	30.1
Average speed (km/h)	26.6	26.6	36.3	36.1
Stops per km	3.8	3.0	1.4	1.3
Aggressiveness (m/s ²)	0.224	0.192	0.208	0.204
Climbing gradient (m/km)	6.46	4.98	5.69	6.39
Descending gradient (m/km)	-5.91	-5.56	-5.91	-6.15

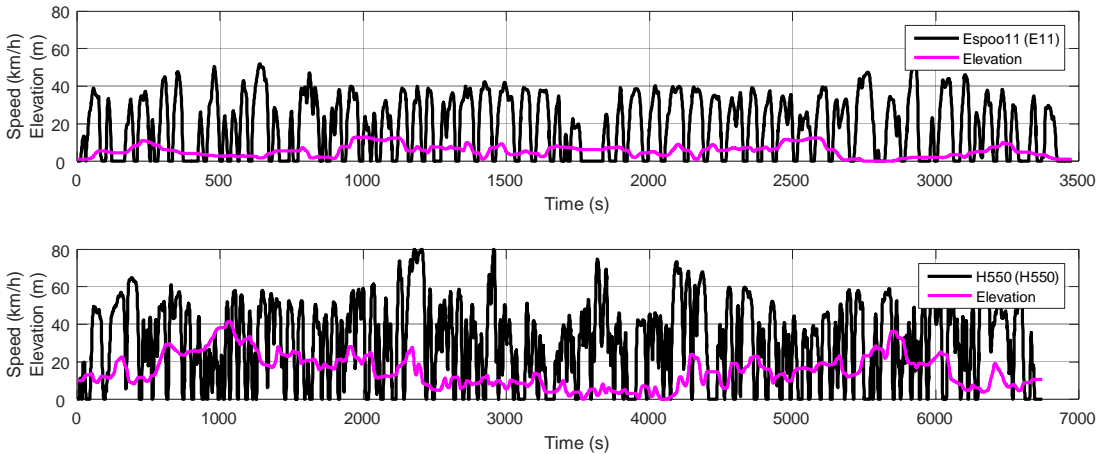

Figure 63. Speed and elevation profiles of simulated operating routes.

5.3.5 Results

Figure 64A shows the energy consumption of the electric bus with different battery capacities in both operating routes. The more frequent stops on the Espoo 11 route causes a little higher energy consumption than on route H550. According to the simulation results, the impact of the increased weight due to the higher battery capacity is not significant. The energy consumption increases only 4% from the 60 kWh battery to 120 kWh. The downside of the bigger battery is less capacity for passengers. **Figure 64B** presents the yearly consumed energy for one bus. Since the average speed on the H550 route is higher, the amount of yearly consumed energy is significantly higher. The charging losses are about 11% from the total consumed energy.

Figure 65 presents the operating range for the different electric bus configurations. Even though a larger than 60 kWh battery would not be required for the bus operation since the battery is charged during operation, there could be other reasons for why the battery capacity would be bigger than the minimum possible. **Figure 65A** shows the total operating range of the electric bus configurations in both driving cycles calculated by using 90% depth-of-discharge. The half distance of the roundtrip in the Espoo 11 route is less than 10 kilometres and in the H550 route less than 30 kilometres. In this context, the smallest battery capacity option (60 kWh) would provide energy only for one round trip on the H550 route and for three round trips in Espoo 11 route if charging were not available. The same numbers for the 120 kWh battery are obviously twice as much, hence two round trips for the H550 and six for the Espoo 11 routes. **Figure 65B** shows the operating range without charging at the end station or en route. This can be assumed to correspond to the operating range of driving back to the depot. As the distance of the H550 route is much longer, the remaining battery energy would only provide a very short driving distance with a 60 kWh battery (< 20 km), whereas in the Espoo 11 route the same battery energy would be enough for more than 30 kilometres of driving.

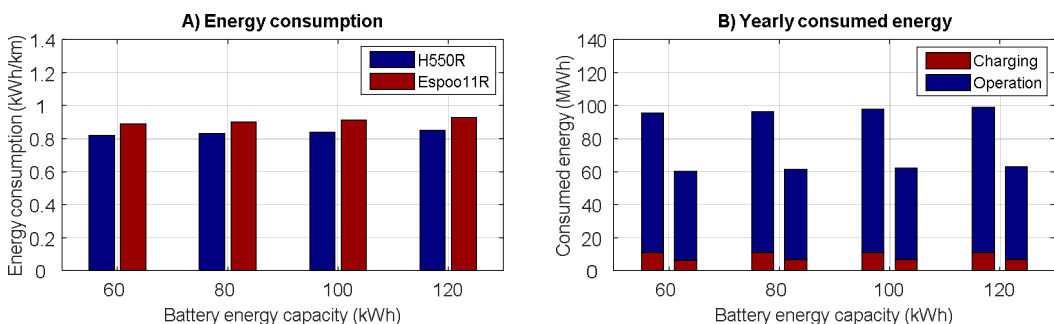

Figure 64. Distance-based and yearly energy consumption of the electric bus.

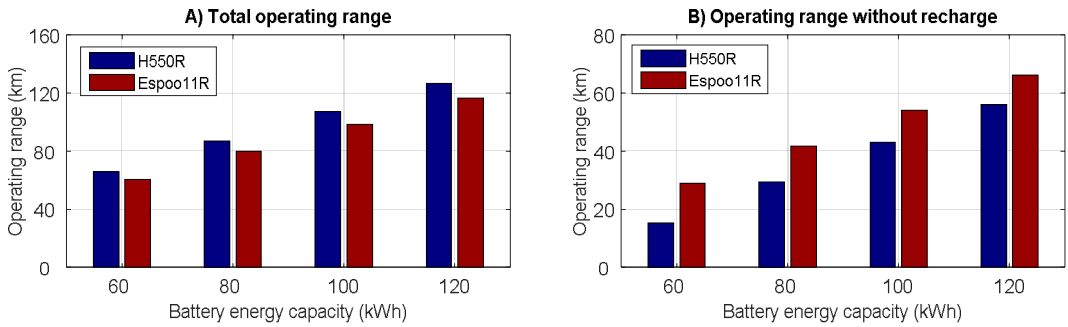

Figure 65. Operating range of the electric bus.

Figure 66 shows the distance-specific costs (€/km) for the electric city bus with both charging options and battery capacities of 60 and 100 kWh. To better understand the costs of the electric buses, the costs of a corresponding diesel bus are also presented in all figures. Since the driven distance in the H550 route is much higher than in the Espoo 11 route, the distance-specific costs are significantly lower for the H550 route. The en-route opportunity charging is significantly more expensive than the end station charging due to the high share of the charging device costs. According to the results, the end station charging costs are only slightly higher than the lifecycle costs of the diesel bus.

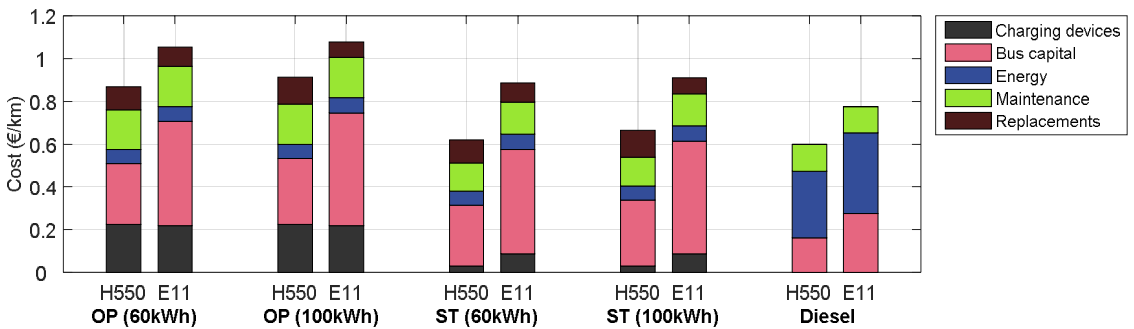

Figure 66. Distance-specific lifecycle costs for the opportunity and end station charging.

Figure 67 presents the time-specific costs calculated per operating hour. From this point of view, the costs are lower for the Espoo 11 route because the operating hours are the same for both routes but the driven distance in the H550 route is still higher, which increases the maintenance, energy and replacement costs per operated hour.

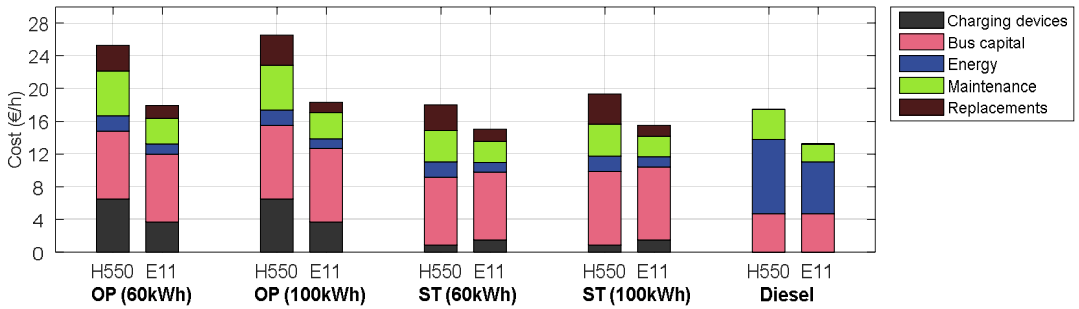

Figure 67. Time specific lifecycle costs for the opportunity and end station charging.

Figure 68 and **Figure 69** show the cumulative lifecycle costs over the service life for a bus fleet for both operating routes and for both charging methods. The sudden increases in the costs of electric buses correspond to the battery replacements, which happen more often for the smaller battery option. Overall, there are not many differences between the different electric bus options, therefore it can be concluded that the battery capacity has a minor influence on the lifecycle costs. The charging method has a significant impact on the lifecycle costs, as can be seen by comparing the results between **Figure 68** and **Figure 69**.

The lifecycle costs breakdown comparison between the opportunity and end station charging is presented in **Figure 70** and **Figure 71**. The same breakdown is also shown for a diesel bus. **Figure 70** presents the breakdown for the Espoo 11 route and **Figure 71** for the H550 route. The presented electric bus configurations have the lowest lifecycle costs among the different electric bus configurations. These figures reveal three key factors in the lifecycle costs of electric and diesel buses: 1) the energy (fuel) costs of the diesel buses represent a major part of their total costs, 2) the capital costs of the electric buses represent a major part of their total costs, and 3) the lifecycle costs of the charging devices depend heavily on the charging method and operating route.

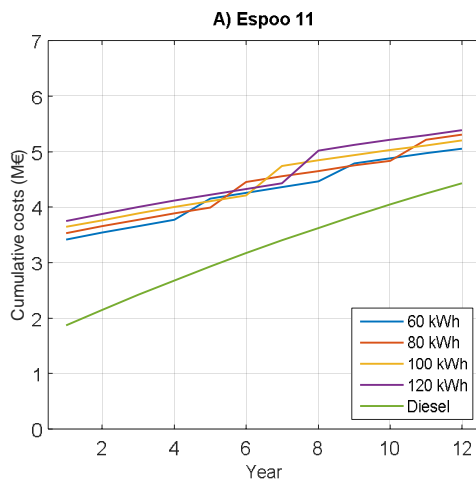
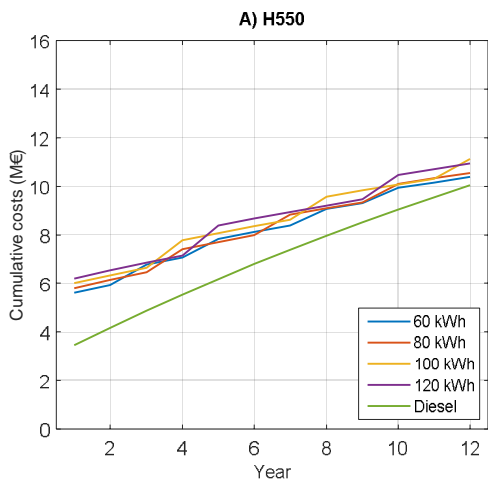

Figure 68. Cumulative total lifecycle costs of a bus fleet with the end station charging.

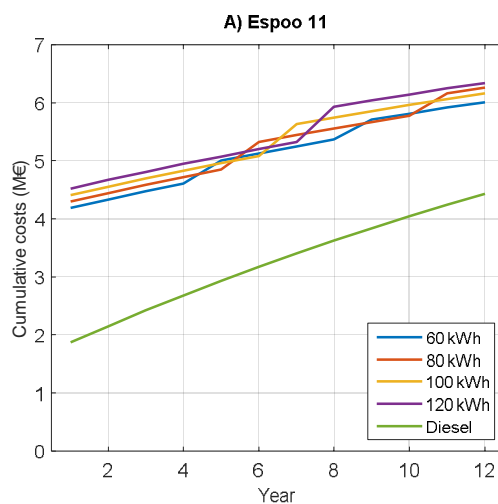
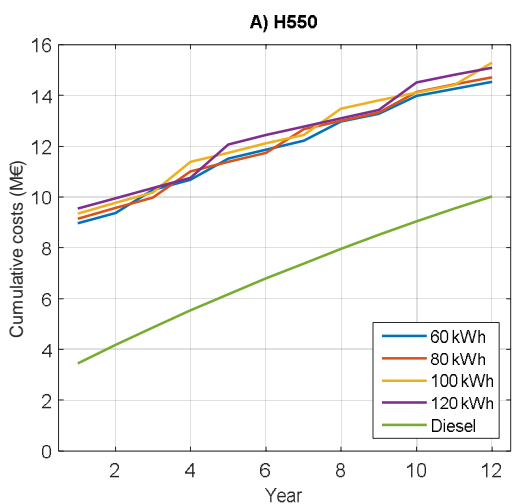

Figure 69. Cumulative total lifecycle costs of a bus fleet with the opportunity charging.

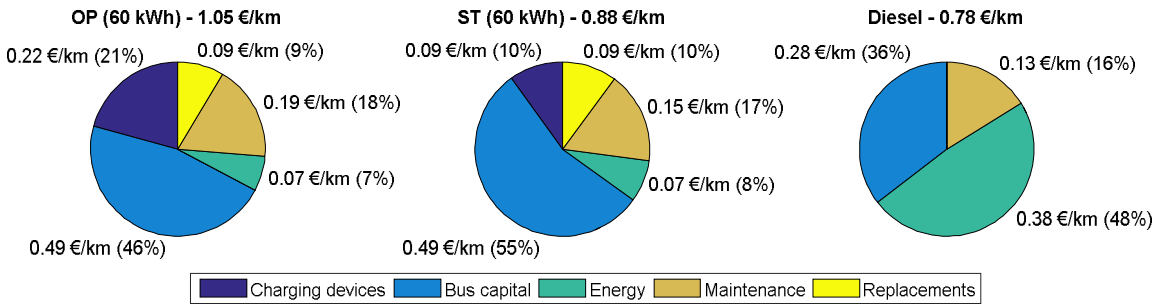

Figure 70. Lifecycle costs breakdown for the Espoo 11 route.

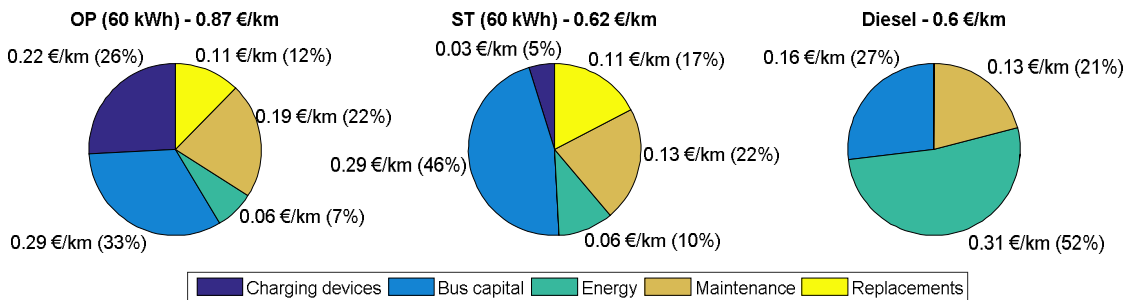

Figure 71. Lifecycle costs breakdown for the H550 route.

5.3.6 Conclusions

Battery electric city buses can already be considered as economically sustainable replacements for traditional diesel city buses. Recent developments in battery technology and fast-charging devices make it possible to operate electric buses in any type of route without worrying about the operating range. The research results show that the lifecycle costs of battery electric buses depend on the fast charging method, and that the costs can vary considerably between different types of operating routes. In comparison to diesel buses, the battery electric buses still have slightly higher lifecycle costs but the costs of the key technologies are decreasing every year. The challenge is the capital costs, which represent on average 50% of the total costs. The purchase cost of diesel buses is about 35% of the total costs.

Implementation and deployment of electric buses requires more preparation than diesel buses. There are different options for the charging method and bus configuration. The most suitable charging method depends on the route characteristics and available bus technology. One of the challenging decisions is choosing the battery

capacity, as batteries are expensive and the operating performance of the bus (system) is heavily dependent of the battery. The results of this study indicate that higher battery costs due to the higher battery capacity (battery size) are in fact almost negligible in relation to the total lifecycle costs. The battery size also has no significant impact on the energy consumption. However, the driving range is heavily dependent on the battery energy capacity, with higher capacity providing longer operating range. If the battery energy capacity is increased, at the same time, the passenger capacity is reduced, due to the increased weight and size of the battery.

5.3.7 Acknowledgements

The author would like to acknowledge the technical and financial support from the ECV-eBus project, which is partly financed by the Finnish Funding Agency for Technology and Innovation (Tekes).

5.4 Guiding system for energy efficient electric bus operation

Authors: Teemu Halmeaho, Jari Kataja, Marko Antila, Paula Silvonen and Mikko Pihlatie

Affiliations: VTT Technical Research Centre of Finland Ltd

Contact information for main author: mikko.pihlatie@vtt.fi

Abstract

Electric bus energy consumption is mainly due to vehicle traction. Additionally, auxiliary systems such as cabin heating and cooling, the air compressor, and power steering consume energy. One way to optimise consumption is a Driver's Aid System (DAS). Based on the route information, DAS provides the driver with the optimal driving suggestions, and simultaneously may optimise the energy use of auxiliary systems. This paper describes how a driver aid system, originally developed for diesel buses, is adapted to allow for use on electric buses. A generic method for learning low-energy driving patterns from data gathered from the vehicle CAN bus is introduced. The profiles are learned using unbiased drive ranking to find seed data for the method. Approaches for reducing energy consumption are discussed in the paper. When the optimal air compressor operation was introduced, vehicle energy consumption decreased 1.6% and another 1.6% with optimal power steering operation according to simulations. In addition to guiding the auxiliary devices and the driver, the prospects for a bus operator of using DAS as a communication hub for managing electric buses, their charging, and for sharing information are discussed.

5.4.1 Introduction

In the near future, hundreds of electric buses will be operated within a single city by different bus operators. A well-planned system is needed to manage the re-charging of the fleets. Even at carefully planned system is vulnerable, for example, to issues in electricity distribution, which could lead to situation where charging demand exceeds capacity. The most promising approach to electric city bus charging infrastructure is believed to be the opportunity charging concept, where the high-power quick charging takes place the bus (end) stops and in bus hubs. Buses designed around this concept have small capacity batteries to solve the issue of the higher price of the high-charging-power batteries. With these small batteries, there is always a risk of running out of charge, leading into stoppage.

As the Public Transport Authority (PTA) is responsible for managing the transport system and ensuring smooth operation, it should also have a strategy for abnormal operation situations. To this end, data from in-service buses are needed for the charging management system to (automatically) identify e.g. the buses in most urgent need of re-charging. Therefore, on-line data collection is needed for every electric bus. In addition, the driver should have access to information related to the dynamic charging plan for the bus being driven. The driver's assistance system can therefore work as a central information system to guide the driver not just regarding the optimal driving style, but also inform about the charging strategy. The bus operator, on the other hand, is interested in remote fault diagnostics of the bus's components, monitoring the performance of the drivers in the sense of energy consumption, and in maintaining speed limits and timetables.¹²³

Road transport accounts for over 10% of the global carbon footprint. It has been estimated that efficient driving has the potential to yield fuel savings of up to 20%. In the near future, electric buses will become increasingly common. Although the wider use of electric buses will reduce the need for lowering the fuel consumption of diesel buses, it will be a while before diesel buses will be fully obsolete. Even if the use of an electric vehicle in itself reduces the carbon footprint, the choice of driving style is not unimportant. Due to the limited range, it is important to use the stored battery energy in the most optimal manner possible.

Although originally developed for diesel buses, the driver's aid device can also be used for electric buses. The monitoring system collects data on sections of efficient driving, which are used to identify the best driving profile for a specific bus route. The driver's assistance system will be even further developed to include the optimal operation of the subsystems. In normal conditions, driving and system operation will follow the pre-defined optimal guidance. For abnormal conditions, the guidance should adapt and change to a corresponding mode.

The energy efficient control of subsystems can be identified either with simulations or using the same "learning during operation" principle as the original driver's

¹²³ Halmeaho T., Antila M., Kataja J., Silvonen P., Pihlatie M. Advanced Driver Aid System for Energy Efficient Electric Bus Operation, in Proc. VEHITS 2015, Lisbon, April 2015.

aid. As an example of the subsystems, auxiliary components are chosen for the purpose. The potential of intelligent operation in this case is discussed in this paper.

5.4.2 Future needs for communication and data sharing with electric buses

To increase the share of low-emission buses in the Metropolitan Helsinki area, Finland, the local PTA, Helsinki Region Transport (HSL), has announced that they are aiming at ramping up the share of fully electric buses to 1% in 2015, 10% in 2020 and 30% in 2025.¹²⁴ In various other major European cities, similar actions are also being taken.

For fully electric operation, the two main alternatives for charging strategy are an electric bus with a large battery (depot charging concept) and one with a small battery (opportunity charging concept). The choice between these two has significant impact on the designed infrastructure and the cost of the system. Practical issues, such as charging standards when connecting the charger and the vehicle physically, as well as protocols for the information exchange are yet to be solved. The bus operators and other stakeholders, including end users and those responsible for the costs are interested in the total cost of ownership if diesel buses were replaced with electric buses. As the best choice tends to be case-specific, careful planning is needed. However, designing the system beforehand is extremely difficult, and currently the charging infrastructure is often over-dimensioned, with a surplus of charging devices along the route.¹²³

At present, the driver's aid systems are focused on assisting the driver to survive in special situations or to add safety functions to driving. As an example, pedestrian detection has been tested by means of machine vision,¹²⁵ while a multi-sensor approach has been developed for preventing lane crossing.¹²⁶ To perform better in demanding tasks, such as parallel parking, driver's aids have also been researched.^{127,128}

For optimising energy consumption e.g. in bus operation or in any other fixed schedule transportation application where the route is predetermined, there has not

¹²⁴ HSL, 2014. HSL mukana Maailman ympäristöpäivässä: Joukkoliikenne muuttuu päästöttömäksi. [HSL News bulletin] 5 June 2014. Available at <<https://www.hsl.fi/uutiset/2014/hsl-mukana-maailman-ymparistopaivassa-joukkoliikenne-muuttuu-paastottomaksi-4934>> [Accessed 13 Nov 2015] (in Finnish).

¹²⁵ Geronimo, D., Lopez, A.M., Sappa, A.D., Graf, T. Survey of Pedestrian Detection for Advanced Driver Assistance Systems. *IEEE Transactions on Pattern Analysis and Machine Intelligence*, **32**(7), 1239–1258, 2010.

¹²⁶ McCall, J.C., Trivedi, M.M. Video-based lane estimation and tracking for driver assistance: survey, system, and evaluation. *IEEE Transactions on Intelligent Transportation Systems*, **7**(1), 20–37, 2006.

¹²⁷ Ozkul, T., Mukbil, M., Al-Dafri, S. A fuzzy logic based hierarchical driver aid for parallel parking. In *Proceedings of 7th WSEAS Int. Conf. on Artificial Intelligence, Knowledge Engineering and Data Bases*. University of Cambridge, UK, 20–22 February 2008.

¹²⁸ Vorobieva, H., Glaser, S., Minoiu-Enache, N., Mammar, S. Automatic Parallel Parking in Tiny Spots: Path Planning and Control. *IEEE Transactions on Intelligent Transportation Systems*, **16**(1), 396–410, 2015.

been much research activity, although some general patents exist.¹²⁹ The closest research activity is related to an active acceleration pedal, which effectively has a similar target.¹³⁰

5.4.3 Driver assistance

Optimal driving style for electric city buses

To study the optimal driving style for electric city buses, measured data collected from real-world operation on actual bus route are analysed. The purpose of the study is to identify the effects of driving style on electric bus energy consumption and to compare the identified optimal driving style with the optimal driving style of diesel buses. The basis of the study is the real-time driver assistant device, originally developed for use on diesel buses.

To identify the optimal driving style, driving performance involving the lowest possible consumption is sought and the speed profiles are then analysed. It is anticipated that the optimal driving style for electric buses will differ from that of diesel buses. The main reason is the possibility for regenerative braking and differences in efficiency maps between an electric motor and a diesel engine.

An example of variation in energy consumption is seen in **Figure 72**, where two drivers have been driving the same fully electric city bus on route 11 in Espoo, Finland.

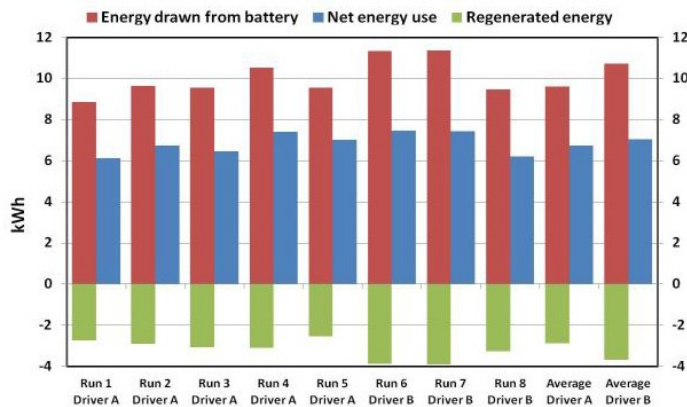

Figure 72. In-service electric energy consumption of a test bus running on route 11, in the city of Espoo.

¹²⁹ Franchineau, J.L., De Verdalle, E. Driving Assistance Method and Device for a Vehicle for Travelling Along a Predetermined Path Between a First Point and a Second Point. U.S. Pat. Application 12/601,600. 2008.

¹³⁰ Várhelyi, A., Hjälmdahl, M., Hydén, C., Draskóczy, M. Effects of an active accelerator pedal on driver behaviour and traffic safety after long-term use in urban areas. *Accident Analysis & Prevention*, **36**(5), 729–737, 2004.

Guiding towards optimal driving style

When the optimal driving style for electric bus has been defined, the follow-up procedure is identical to that of diesel bus data collection, with back-office calculations and other required operations used to produce a driver-assistance system to guide the bus driver in energy-efficient driving, maintaining speed limits and timetables, see **Figure 73**. With the aid of the driver assistance system, it is possible to affect the driver's driving style in real-time. In a diesel city bus, economical driving is achieved by quick acceleration and constant speed that is as low as possible. The system provides real-time guidance to drivers, taking into account vehicle position compared to the scheduled position, the speed limit, and the travelling comfort of passengers, using recommendations on the intensity of acceleration and feedback on the current speed and its relation to the target speed. When determining the speed, it dynamically takes into account the timetable: If the bus is ahead of schedule, the constant speed can be lower.¹²³

On diesel buses, a saving potential of 5–10% has been realised when the driver assistant system has been demonstrated and tested. The better the driver follows the guidance, the greater the savings that can be achieved.

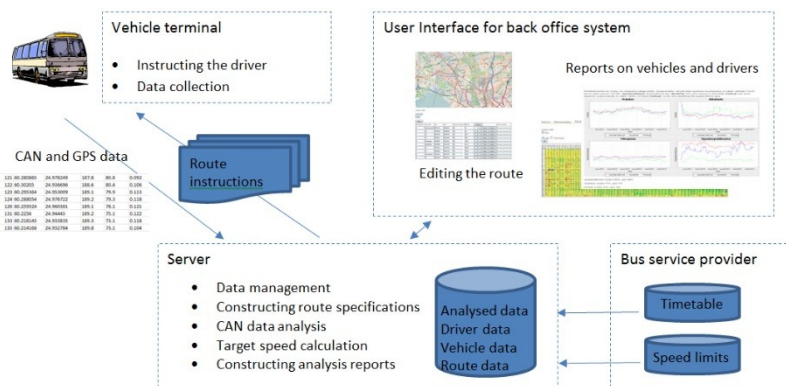

Figure 73. Communication between the components of the driver assistance system.

The collected data during the operation is transferred wirelessly to a back office system consisting of server software and a browser-based user interface. The server software automatically processes and analyses data recorded on the bus route. The analysis reports can be viewed in the user interface. The on-board terminal device manages the collection of measurement data and its transmission to the server, and also the actual display of guides for the driver. To operate, the guidance needs route-based instructions. For this, necessary data, such as timetables and speed limits, are collected from other systems by the server software. After a learning period, the target speeds for the bus route are calculated using data that

are collected during the operation. Location information like Global Positioning System (GPS) coordinates and vehicle speed with energy consumption are essential variables to enable the monitoring system to compare current operation with the timetable. Using this background data, location-based target speed profiles are created for each bus route. Initial target speeds for the route can be, schedule permitting, e.g. 5% lower than the respective speed limits. The system will then adjust these speed instructions according to the learned optimal driving style. The route can be edited in the user interface, if some of the background data cannot be collected automatically. The route is presented to the terminal device as a list of GPS coordinate points with their target speeds, with information on the bus stops, speed limit changes, and other relevant factors.

The most recent addition for the driving assistant system is the functionality that enables the partial comparison of driving performances, allowing the analysis to focus on optimally driven stretches between bus stops or on even shorter stretches in order to construct optimum overall speed profiles. If these driving stretches and corresponding partial speed profiles are categorised to form general results, they can be used for adaption to other bus routes as well. Categories can be based on e.g. speed limits, stops, and slow downs (traffic lights, speed bumps, pedestrian crossings and intersections) or on the length and shape (turns and hills) of the stretch.

The method of drive ranking is as follows:

Data. The raw data gathered from vehicles are checked and summarised for analysis. Incomplete and erroneous data are removed. The data constitute a matrix of numerical values logged once a second. The values include, for instance, time, speed, speed limit, location of the vehicle, energy consumption, and time difference to the schedule.

Pre-processing. At the pre-processing stage, incomplete and erroneous data are removed, the system extracts individual driving episodes from the data, and summarises each drive matrix into a vector. The summaries are mostly average values concerning a whole route or part of it, a stretch from one bus stop to another bus stop, for instance.

Calculating the references. 1) Day reference values are calculated. A day reference describes the variation in the values of interest in relation to the time of day. There is a different curve for each weekday that has a differing reference profile. 2) Seasonal reference values are calculated. A seasonal reference describes the variation of the values of interest in relation to the day of the year. The seasonal reference curve is a moving average of the average values for each day. 3) Seasonal reference values are calculated for each vehicle. As different vehicles may have different consumption rates, seasonal references are separate profiles. By removing the vehicle's impact from the drive data, we can compare the performance of different driving episodes without a vehicle-dependent bias. 4) Each driving episode is evaluated using appropriate day and vehicle-specific reference corrections. 5) A moving average result is calculated for each vehicle.

When a driving episode is compared to these reference profiles, the deviation from the profile is an unbiased value that is used to describe the driving episode

and to find speed profiles where consumption is as small as possible, taking into account all conditions relating to environment.

5.4.4 Auxiliary device energy consumption

In diesel buses, auxiliary device energy consumption consists of an engine cooling fan, an air compressor, air conditioning, power steering and an alternator to run 24 V devices such as lightning. For fully electric buses, the engine cooling fan can be taken away from the list and separate alternators are not used, while the equivalent to the 24 V auxiliary device consumption does exist. In addition, electric buses use this low voltage source for many low power auxiliaries, e.g. the fans and pumps of the powertrain cooling circuit. Instead of an alternator, DC/DC converter is used to produce low voltage electricity from the high voltage of the traction battery. Regenerative braking energy via the drive motor is also used to produce the low voltage electricity.

As reported by Erkkilä et al., the energy consumption of auxiliary components in diesel-powered city buses is only marginal.¹³¹ During the summer time, the average consumption for power steering was under 1% (in relation to energy available on the crankshaft). In the same study, the air compressor consumed 2% and air conditioning 3% of the energy. During wintertime, the auxiliary heater was responsible for 20% of the total energy consumption.

Albeit that the relative energy consumption of the auxiliary components is low in diesel buses, the same amount of energy in an electric bus means a higher relative portion of the total energy consumption. On the left in **Figure 74**, an example is shown of the energy usage of auxiliary components (of total battery energy) during operation on an actual bus route.

¹³¹ Erkkilä, K., et al. Energy efficient and intelligent heavy vehicle – HDENIQ Final report. [pdf] Espoo, Finland: VTT Technical Research Centre of Finland. 2012. Available at: http://www.transco.fi/files/783/Energy_Efficient_And_Intelligent_Heavy_Vehicle_HDENIQ_Final_Report_VTT-R-08344-12.pdf [Accessed 13 Nov 2015].

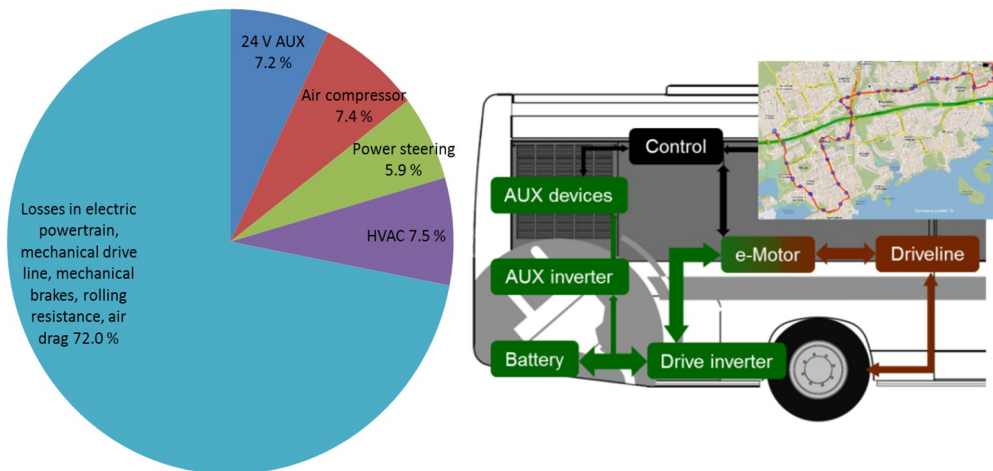

Figure 74. Measured share of auxiliary component energy consumption in electric city bus during real-life operation on route 11 in Espoo, Finland at 15 °C ambient temperature (left). Subsystems of the auxiliary device energy consumption model (right). The coordinate data are included in the model and are shown in a map at the top of the figure.

In this example, the consumption of Heating Ventilation and Air Conditioning (HVAC) was minimal, because the outside temperature was 15 °C and only a small amount of heating or cooling was required. Some of the energy required by the HVAC system is seen in the 24 V AUX consumption, as the fans of the HVAC system (air source heat pump) are connected to it. In this particular case, the fans were responsible for half of the 24 V AUX energy consumption. To produce maximum heating or cooling power, the combined energy consumed by the fans and the actual HVAC will be at least four times as much. On a cold winter's day, additional heating would also be needed to maintain the cabin at the desired temperature. The need can be four times the maximum power of the air source pump and a fuel-operated heater.

The optimisation of the subsystems' operation adds a further potential for energy savings. Even though the driving losses due to the vehicle traction are responsible for a large part of the battery energy consumption, the subsystems waste most of the energy. The biggest driving losses in city buses are caused by the rolling resistances of the tyres. In the subsystems, powertrain components, such as the mechanical driveline and electric motor with an inverter, produce losses during operation due to the limited efficiency in the power transmission. Mechanical brakes are used for deceleration and significant losses are generated, which can be reduced through regenerative electric braking. Besides the powertrain components, subsystems also include the auxiliary components. These are not mandatory for vehicle traction, but may in some cases consume a considerable amount of energy. In order to study and optimise the power consumption of the auxiliary subsystems, a

MATLAB Simulink model was developed. The dynamics of the bus has been modelled with Simscape.¹³² The main subsystems of the model are shown on the right in **Figure 74**.

Potential for energy savings through optimal operation of the auxiliary components

During the simulation, the bus is driven on an actual bus route, route 11 in Espoo, Finland, with bus stops and other traffic. The speed profile and the auxiliary component energy consumption are measured and utilised by the simulation model. Stopping at bus stops and traffic lights and following the road with junctions and turnings requires steering, braking and opening the bus doors. Auxiliary device consumption is thus dependent on the bus route and also on the ambient conditions, which demand using HVAC for passenger and driver comfort. Power consumption of the auxiliary devices is modelled using a system identification approach. The electricity consumption of the power steering and air compressor has been measured. Based on the measurement data and the bus route, mathematical models of the energy consumption of the given auxiliary devices can be created.

Energy consumption of the power steering is related to the operation of the hydraulic pump. Based on the measurement data, power consumption of the hydraulic pump correlates with the bus speed. When the bus is stopped at traffic lights or at a bus stop, for example, the power consumption is zero. Otherwise, the consumption is relatively constant. The measured bus speed and power consumption of the hydraulic pump are shown in the upper part of **Figure 75**. Based on this relation, a model of the power consumption was created. The measured and modelled power consumptions are shown in the lower part of **Figure 75**. The cumulative power consumption in both cases is 0.485 kWh. The model was also validated with another dataset from the same bus route, resulting in cumulative power consumption of 0.366 kWh while the measured consumption was 0.363 kWh. This indicates that the model gives reliable and accurate results.

¹³² Halmeaho, T., Rahkola, P., Pippuri, J., Tammi, K. Hybrid City Bus Design Evaluation Using System Level Simulations, in Proc. ISIE 2014, 2014. DOI:10.1109/ISIE.2014.6864866.

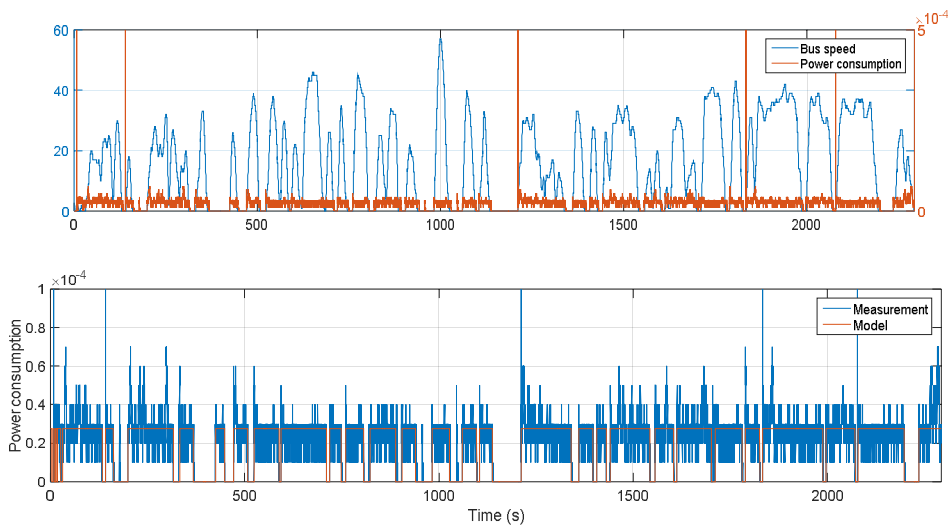

Figure 75. Relation between bus speed and power consumption of the hydraulic pump (upper) and measured and modelled power consumption of the hydraulic pump (lower).

Power consumption of the hydraulic pump can be optimised by switching the pump off when power steering is not used. A case where the power steering pump is switched off when the turning angle of the bus is zero was simulated. This optimised power consumption was 0.354 kWh, which is 27% less than without the optimisation scheme (1.6% in total vehicle energy consumption). With the validation dataset, the optimised consumption is 0.293 kWh, which equates to 20% power saving.

The potential for utilising optimal air compressor operation to reduce overall energy consumption was also examined. The potential for energy savings comes from the battery efficiency and limited charging current. The cycle efficiency of the battery is optimally around 95-96%, hence using a battery to store energy wastes only a marginal amount of energy. However, the battery charging current limit is extremely sensitive to the battery temperature. During wintertime, the permitted current can decrease into at least one third of the maximum, which will limit the regenerative motor power. However, the regenerative power could be increased if there was alternative electric load available. For this purpose, the compressor was modified to activate only at adequately long and hard decelerations, while it is normally activated based on air consumption. The air compressor energy consumption was equal in both strategies. The battery charging limit was set to 45 A, which represents the actual measured limit permitted by the Battery Management System (BMS) in +3 °C ambient condition.

In **Figure 76**, the results of using the modified and normal compressor activation strategy are compared. On the left, the used speed profile is shown together with the cumulative battery powers separately for charging and discharging directions. On the right, a partial stretch of the cycle is presented and the differences for battery

and motor operation can be seen when the baseline or modified air compressor activation strategy is used. Energy saving is achieved because of the higher regenerative motor power and avoiding the unnecessary charging and recharging losses in the battery.

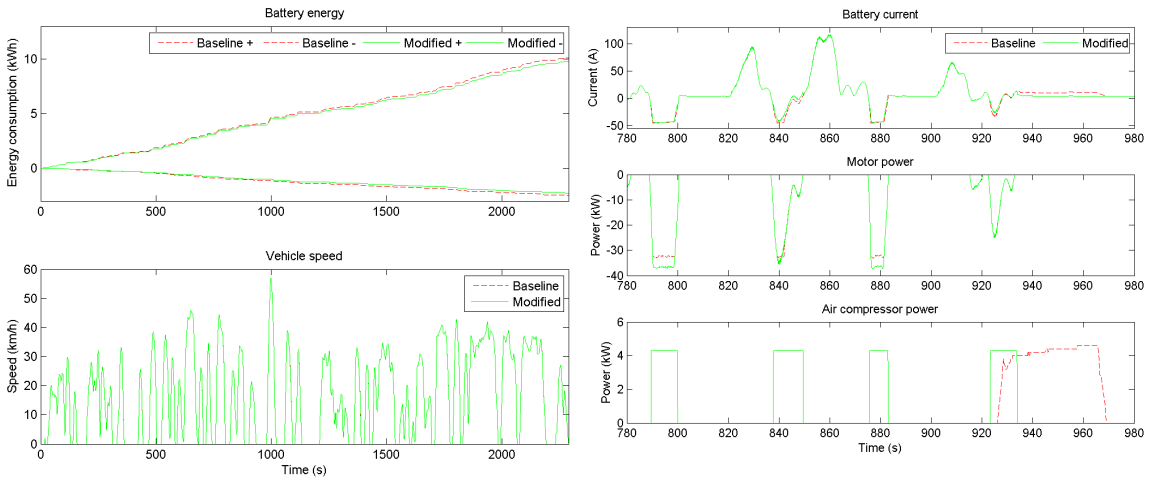

Figure 76. Simulated cumulative energy consumptions and realised speed profiles for baseline and optimal air compressor operation during the whole cycle length (left) and simulated battery current, motor power and air compressor power for baseline and optimal air compressor operation during part of the cycle length (right).

The realised cumulative saving during the whole cycle was 0.13 kWh (23%), which means a 1.6% decrease in the overall vehicle energy consumption. The total consumption of the compressor was 0.56 kWh during the cycle. Not all of this potential is available for recovery, because the system is already during in baseline operation inherently feeding the energy for consumers during the regenerative braking. In addition, the timing of the compressor usage at baseline often occurs during the hardest decelerations, while on the other hand, many of the additional compressor activations in the modified strategy occur in low power regeneration and the current limit is not met. Although the achieved energy saving was small for this particular case, higher savings can be anticipated when HVAC usage is also be optimised. This could include boosting HVAC power when braking, thus storing braking energy as cold/hot air in the cabin and making it possible to switch off HVAC for some time. The speed profile route 11 had only modest decelerations, and therefore the battery current limit was exceeded only a few times. During a more dynamic cycle, the saving potential is higher.

5.4.5 Conclusions

Electric buses in comparison to conventional buses have the potential for increased energy efficiency, zero tailpipe emissions, and decreased noise caused by city transport. This paper described a driver-assistant system to be used for guaranteeing an optimal driving style for electric city buses. The system will be further developed to include the intelligent control of various subsystems. Optimal operation of auxiliary components was discussed in the paper. Auxiliary components in electric buses are inherently controlled in a more energy efficient manner than in diesel buses. Nevertheless, some improvements in efficiency can be still achieved by using intelligent control. A simulation model that is used for studying the optimal operation of electric vehicle subsystems was described. Simulation results based on an optimised use of the air compressor activation was presented. Overall energy consumption of the vehicle was reduced by 1.6%. The savings can be further increased by considering HVAC optimisation.

An empirical model of the hydraulic pump energy consumption based on measurement data was created and validated. The model was also used for optimisation of the energy consumption and over 20% of the power used by the hydraulic pump can be saved if the pump is switched off when power steering is not needed. This also yielded a saving of 1.6% of total energy consumption.

A future task is to create an empirical model of the air compressor in a similar way as with the hydraulic pump. The air compressor is used by the brakes, suspension, and doors. Usage of brakes has been measured and the opening of doors can be estimated based on speed and locations of bus stops.

Based on the bus route information, the proposed advanced driver's aid system could combine driver guidance and the optimal use of auxiliary components to achieve more energy efficient electric city bus driving. In the future, it could also include a communication interface for bus fleet management.

5.4.6 Acknowledgements

The authors acknowledge the financial support for the research work received from the Electric Vehicle Systems (EVE) programme funded by Tekes – the Finnish Funding Agency for Technology and Innovation.

6. Electric vehicles vs. power grid

6.1 Electric vehicle controlled charging

Authors: Ville Tikka, Juha Haakana, Jukka Lassila, Jarmo Partanen

Affiliations: Lappeenranta University of Technology

Contact information for main author: ville.tikka@lut.fi

Abstract

The electric vehicle (EV) market has shown its first signals towards increasing the number of smart charging applications. Thus, technical pilots play a critical role in testing EV charging applications. The main aim of the paper is to deliver a brief introduction to the grid effects of electric vehicle charging and to describe an implementation of the smart-charging test environment. The paper describes the main properties and functionality of the EV charging test environment. The market potential of the EV charging business is also briefly discussed. The test environment is built to enable multi-objective optimisation goals by providing versatile resource selection and highly configurable control logics. The main result of the study was full implementation and validation of the testing environment for smart charging applications.

6.1.1 Introduction

The EU's energy policy has set clear target towards low-carbon and sustainable society.¹³³ The transportation sector in Finland produces 19% of the total CO₂ emissions, with the total reported greenhouse gas emission production being 63 069 ktCO₂-eq in 2013.¹³⁴ Thus, the transportation sector plays a critical role in cutting down greenhouse gas emissions. The transportation sector can be divided into four main classes: air traffic, railroad traffic, marine traffic and road traffic. Road traffic plays the major role in producing emissions, with a share of 93% of the total traffic emissions.¹³⁵ The number of cars in Finland has also increased steadily over recent years, standing at 3.2 million in 2014.¹³⁶ Private passenger cars will undergo dramatic changes in the coming decades, and thus the impacts of changing structures of the traffic need analysing. The changing world also poses new business opportunities in the sector, and thus a novel pilot related to infrastructure plays a key role. The paper briefly presents research aimed at determining the grid impacts

¹³³ European Union, European Union Energy Strategy, 12 2015. [Online]. Available: <http://www.ec.europa.eu/energy/en/topics/energy-strategy>.

¹³⁴ Statistics Finland, Greenhouse gas emissions in Finland, 2015. [Online]. Available: <http://pxnet2.stat.fi/PXWeb/pxweb/en/StatFin/>.

¹³⁵ Motiva, Energy Consumption and Exhaust Emissions. [Online]. Available: http://www.motiva.fi/en/transport/the_environmental_impacts_of_traffic_in_finland/energy_consumption_and_exhaust_emissions.

¹³⁶ Statistics Finland, Number of vehicles registered, 2015. [Online]. Available: <http://pxnet2.stat.fi/PXWeb/pxweb/en/StatFin/>.

of EV charging. An example of a practical pilot demonstration that utilised an EV charging test bed was implemented as part of the Electric Commercial Vehicles (ECV) eCharge project.

6.1.2 Methodology and case examples

In this chapter, the methodology and case examples are briefly described. The paper provides a short introduction to stochastic load modelling on EV charging, but also gives a description of smart charging test beds implemented in the campus area of the Lappeenranta University of Technology.

6.1.2.1 Load estimations by means of stochastic simulation

The grid effect of EV charging are studied by means of a literature study and stochastic modelling. The grid impact of EV charging has been studied widely all over the world,^{137 138 139 140} The research results suggest that the grid impact of EV charging is highly dependent on the grid infrastructure and how charging is performed. The present study considers an example urban case to demonstrate case scenarios in the event that grid-optimised smart charging is selected. Grid optimisation in the current case refers to a charging scheme that aims to maximise utilisation of the free grid capacity in the area. The case also enlightens us on how different EV penetration levels might change the grid load on the low voltage (LV) side. The load is modelled by means of stochastic modelling, and is described in more detail in earlier work.^{141 142} **Figure 77** describes the case area briefly and **Figure 78** demonstrates the load change on the LV grid in the area in the event of controlled charging. In the event of uncontrolled charging in the area the LV grid's peak loads can increase substantially.¹⁴¹

¹³⁷ Wu, Q., Nielsen, A., Ostergaard, J., Cha, S.T., Ding, Y. Impact study of electric vehicle (ev) integration on medium voltage (mv) grids, in Innovative Smart Grid Technologies (ISGT Europe), 2011 2nd IEEE PES International Conference and Exhibition on, Dec 2011, pp. 1–7.

¹³⁸ Veldman, E., Verzijlbergh, R. Distribution grid impacts of smart electric vehicle charging from different perspectives, IEEE Transactions on Smart Grid, **6**(1), 333–342, Jan 2015.

¹³⁹ Rautiainen, A., Repo, S., Jarventausta, P., Mutanen, A., Vuorilehto, K., Jalkanen, K. Statistical charging load modeling of phev in electricity distribution networks using national travel survey data, IEEE Transactions on Smart Grid, **3**(4), 1650–1659, Dec 2012.

¹⁴⁰ Zhaoxi Liu, Q.W. D2.2. EV Charging Analysis with High EV Penetration in the Nordic Region, Danmarks Tekniske Universitet, Tech. Rep., 2013. [Online]. Available: <https://www.sintef.no/globalassets/project/norstrat/d2.2---ev-charging-analysis-with-high-ev-penetration-in-the-nordic-region.pdf>.

¹⁴¹ Tikka, V., Lassila, J., Haakana, J., Partanen, J. Case study of the effects of electric vehicle charging on grid loads in an urban area, in Innovative Smart Grid Technologies (ISGT Europe), 2011 2nd IEEE PES International Conference and Exhibition on, Dec 2011, pp. 1–7.

¹⁴² Tikka, V., Lassila, J., Makkonen, H., Partanen, J. Case study of the load demand of electric vehicle charging and optimal charging schemes in an urban area, in Innovative Smart Grid Technologies (ISGT Europe), 2012 3rd IEEE PES International Conference and Exhibition on. IEEE, 2012, pp. 1–7.



- Q More than 400 cars parking in the area at night-time
- Q 412 parking spaces with a preheating facility
- Q 412 apartments
- Q 11 apartment houses
- Q 700 inhabitants
- Q District heating
- Q Two low-voltage substations feeding low-voltage grids in the area
- Q Road leading to the area is a dead-end

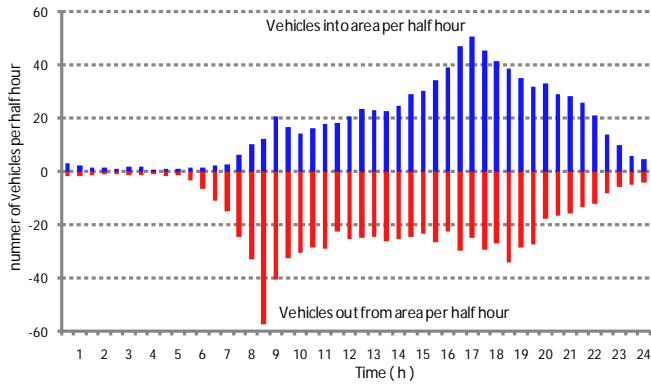

Figure 77. Case area: Pikisaari district of the city of Lappeenranta in Southern Finland in the left image. Average workday traffic flow on the road leading to the case area in the right image.¹⁴²

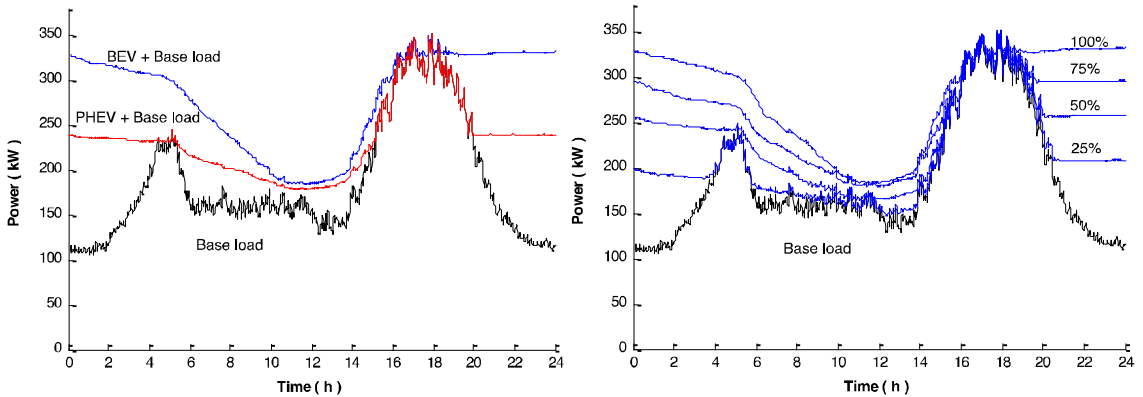

Figure 78. Sum of the base load and charging curves with 100% penetration levels in the event of smart charging with plug-in hybrid vehicles (PHEV) and battery electric vehicles (BEV) in the left figure. Smart charging curves of BEVs with penetration levels of 25%, 50%, 75% and 100% (412 cars) in the right figure.

The results suggest that smart charging may lead to a situation where the peak load of the grid remains unchanged, even in the utmost case of a 100% EV penetration level. The energy transfer in the area is increased, but the peak load remains the same. This leads to an increased grid utilisation level and could potentially lead to a decreased distribution fee unit price paid by the end customer. However, the energy fee is still higher due to the larger amount of energy consumed. The case only considers distribution system operators (DSO's) of interest, but the potential market case could be energy fee minimisation for end customers by charging during low cost hours. Energy fee minimisation is likely to cause peak load concentration during cheap electricity hours and thus to increase peak loads in the grid. However, if a large number of customers charged during cheap hours, a counter-reaction from the market may apply. Eventually, cheap hours may become higher priced or volatility in the market price may decrease.

6.1.2.2 The smart charging test bed

The Green Campus environment at the Lappeenranta University of Technology consists of an environment to test smart charging applications via commercially available charging points and cars, and also of a test environment for custom charging points and cars. This paper present two testbeds operating in the Green Campus environment. The first testbed is built to support custom communication protocols over a PLC Ethernet connection. The second testbed offers a testing environment for commercial electric vehicles supporting mode 3 charging. Mode 3 charging refers to the standardised charging communication protocol defined in IEC 62196.

Figure 79 presents a simplified structure of the custom testbed system and the main components of the modified car.

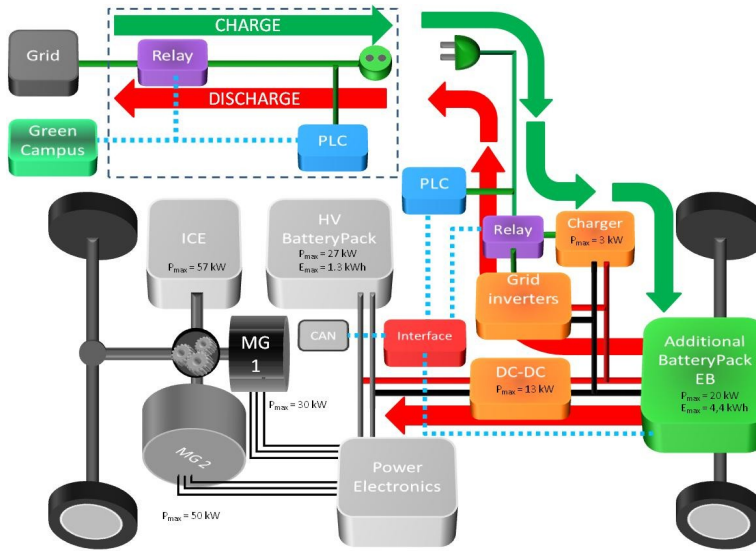

Figure 79. The main components in the Green Campus smart charging pilot. (PLC – power line communication, CAN – control area network, MG – motor/generator, ICE – internal combustion engine)¹⁴³.

The communication between car and the charging pole relies on the custom protocol over TCP/IP, allowing data exchange beyond current standardised communication for EV charging. On board, car communications utilise serial communication to the car's systems and the battery management system (BMS). The car is connected to the EMS system of the Green Campus, which also serves as a database server. The system allows for testing of enhanced smart charging applications and vehicle-to-grid (V2G) functionality. The car also has an integrated metering system to enable accurate verification of the tested smart charging of V2G functions. Control algorithms can be implemented on the car's system locally or the control can be operated remotely from the EMS in the campus area.¹⁴⁴

The campus environment also offers another testbed for testing commercially available EVs with standardised charging protocols. The system includes a custom EMS system that can be used to govern an unmodified mode 3 charging pole. The charging pole has an accurate metering device connected to a database server so as to provide accurate high resolution monitoring during testing of the enhanced control algorithms and cars. The database server allows for storing data on events ranging from seconds to months. **Figure 80** describes the campus environment.

¹⁴³ Makkonen, H., Tikka, V., Kaipia, T., Lassila, J., Partanen, J., Silventoinen, P. Implementation of smart grid environment in green campus project, in Integration of Renewables into the Distribution Grid, CIRED 2012 Workshop, May 2012, pp. 1–4.

¹⁴⁴ Tikka, V., Makkonen, H., Lassila, J., Partanen, J. Case study: Smart charging plug-in hybrid vehicle test environment with vehicle-to-grid ability, in Power Electronics and Applications (EPE'14-ECCE Europe), 2014 16th European Conference on, Aug 2014, pp. 1–10.

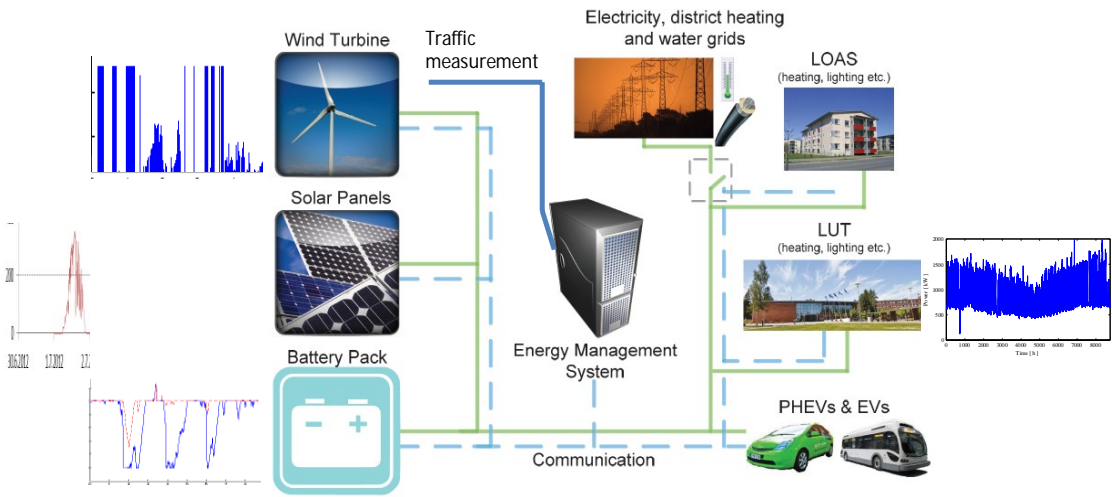

Figure 80. Main components of the Green Campus Smart Grid (LUT – Lappeenranta University of Technology, LOAS – Lappeenranta student housing foundation).

6.1.2.3 Test results on the testbed

The custom testbed has been tested with various control schemes. The frequency containment reserve (FCR) operation is presented in this paper. The operation criteria were set to respond to grid frequency deviations larger than 0.05 Hz from the nominal frequency of 50 Hz. The up-regulation power on the test was 500 W, which corresponds to discharging in the current application. The down-regulation power was set at 3 kW. Such limits allow for the battery state of charge (SoC) to increase during operation as the discharging power is lower than the charging power. According to frequency statistics, the grid frequency has the same amount of variation above and below the nominal frequency. **Figure 81** presents the grid frequency and response power during the test period.

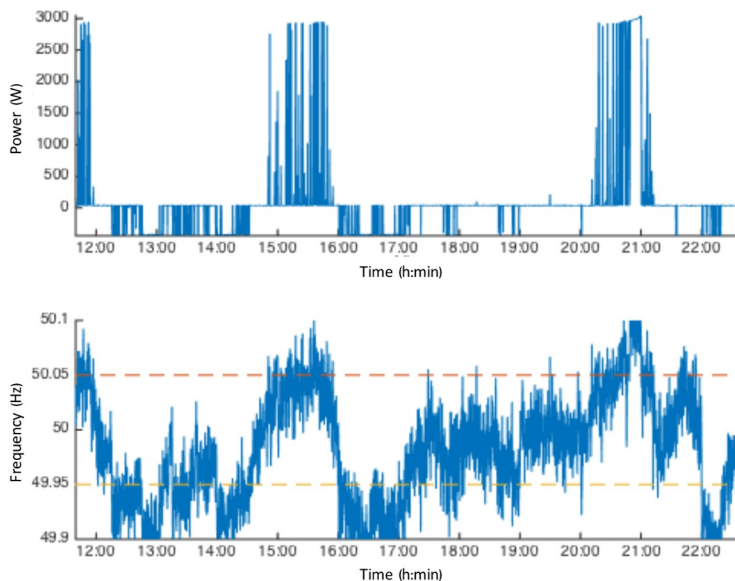

Figure 81. The frequency containment reserve application test on the custom charging test bed. The upper figure presents the power of the charger and the lower figure presents grid frequency. Dashed lines on the frequency figure describe the dead band limit of the frequency containment application.

The frequency containment reserve application was tested and observed as fully functional with the V2G test bed. The assumption of a strong potential for such an application is well justified. The total energy content in the operation of such a frequency containment reserve application is rather low. For instance, if a 1 kW capacity is bid to market, the energy content of the operation is expected to be roughly 0.1 kWh (highly dependent on control parameters). Thus, the operation is seen profitable in many situations as the compensating frequency containment reserves are rather high compared to the energy needed in response.

6.1.3 Discussion

Present research on the topic has indicated that significant changes in the grid loads are possible because of EV proliferation. Uncertainty in customer behaviour and possible high changes in electricity demand may create challenges for DSO business. Smart charging applications may also create a potential conflict of interests between the grid operator and the electricity retailer. The retailer's may also be concerned with third parties that offer load control to end customers. No matter how controlled charging enters the market, conflicts of interest are likely to exist.

Flexible load may be seen as an important and valuable asset in the near future. On the system level, grid frequency containment may benefit from EV charging that

is highly flexible. The grid disturbance might also be partially handled by EV charging applications. The distribution system operator might use EV charging on congestion management and electricity retailer on balance management. The customer may use EV charging as part of the home automation system. However, those different parties using the same resource should be able to arrive at mutual understanding of the rules related to the operation of the resource. The communication between different market players should be solved before flexibility applications become routines in every household or company.

6.1.4 Conclusions

The main outcome of the work was an improved knowledge of the impacts of EVs on the power system. EV charging can be seen as a multidimensional problem since we do not know which charging applications will dominate in the near future. The study suggests that grid effects can be kept to a minimum if charging can be controlled by means of grid-optimised view. The worst case would be a charging application that aims at targets that ignore grid constraints.

The study led to a smart charging testbed that allowed for testing novel charging applications and charging algorithms in practice. The smart charging testbed has been used to demonstrate cost minimisation algorithms and grid support by means of automated frequency-controlled charging, which is set to be used as a frequency containment reserve.

6.2 Electric vehicle charging as a frequency containment reserve on a power system level: a simulation study

Authors: Mika Lötjönen, Antti Rautiainen

Affiliations: Tampere University of Technology

Current contact information for main author: mika.lotjonen@teknoware.com

Abstract

The number of electric vehicles, electric vehicle charging systems and controllable loads has increased in recent years. More wind power capacity and other intermittent renewables (i.e. solar power) are connected to the grid. Wind power and solar power do not directly participate in the frequency control of the power system. Power system reserves are divided to frequency containment and frequency restoration reserves. During normal operation, the frequency is kept in the range 49.9–50.1 Hz and under disturbances, the frequency is kept above 49.5 Hz via reserves in the Nordic grid. Currently, the frequency is controlled during disturbances via load shedding and hydropower generation and other power reserves.

The potential of aggregated electric vehicle chargers and other energy storages as a power system reserve lies in the fast response time of power electronic devices. An electric vehicle's battery storage is a rare case of an instantly activated resource type that is set to increase in the future. In this paper, electric vehicle

charging as a source of frequency containment reserves for disturbances (FCR-D) is studied. In addition, the potential of vehicle-to-grid (V2G) operation is discussed. The power system model utilised in this paper is based on the Nordic grid equivalent model received from Fingrid Oyj, the transmission system operator of Finland. Aggregated electric vehicle charging is modelled as high-power three-phase converters. The impacts of frequency controlled charging as a power system reserve are studied via case studies in PSCAD. The aggregated model utilised in this paper may serve to represent other controllable loads as well.

Based on the case studies electric vehicle charging and V2G has potential as a power system reserve. However, other power system reserves should still be utilised since loads and sources that are behind power electronics cannot replace the high inertia of hydropower machines.

6.2.1 Introduction

The number of electric vehicles, electric vehicle charging systems and controllable loads has increased in recent years. More wind power capacity and other intermittent renewables (i.e. solar power) are connected to the grid. Wind power and solar power do not directly participate in the frequency control of the power system. Moreover, there is no significant need to increase the capacity of hydropower generation, which currently participates in frequency control in the grid.

The response speed of power electronic devices is very fast compared to synchronous generators participating in the frequency control of the grid. Due to this, local and low-voltage studies and demonstrations have been made by controlling the charging power of electric vehicle charging device based on the measured frequency.

However, there has been no study on the potential of aggregated controllable loads and energy storage systems behind inverters as a frequency containment reserve on the transmission system level. The lack of such studies is due to the low number of electric vehicles. Some carmakers introduced V2G in late 2013 on fully electric vehicles and it is also possible to upgrade firmware on earlier models. Bidirectional charging is also being rolled out to the market by some European car manufactures in the near future.^{145,146} In some scenarios, the number of electric vehicles has been projected to increase rapidly. This paper focuses on electric vehicle charging and discharging. However, as a concept similar methods can be applied to other controllable loads and energy storage systems serving as a frequency containment reserve. If the penetration level of electric vehicles and the number of other controllable loads and energy storages as a power system reserve are high there is a theoretical potential to affect the frequency dynamics of the power system.

¹⁴⁵ Power to spare – Nissan and Endesa sign pledge to promote Europe's first mass market vehicle to grid system. <https://uk.nissannews.com/en-GB/releases/release-130188>.

¹⁴⁶ PG&E and BMW team up to test V2G services. <https://chargedevs.com/newswire/pge-and-bmw-team-up-to-test-v2g-services/>.

6.2.2 Methodology

In this paper, the concept of aggregated electric vehicle charging and discharging as a power system reserve is reviewed. The power system model utilised in this paper is based on the Nordic grid equivalent received from Fingrid Oyj, the transmission system operator of Finland. Aggregated electric vehicle charging is modelled as high-power three-phase converters. The impacts of frequency controlled charging as a power system reserve are studied via case studies in PSCAD. In the studied system a generator is disconnected from the system and the built-in frequency measurement of generator nodes is utilised. Two identical aggregated charging models are connected to the grid as shown in **Figure 82**. The charger model utilised is shown in **Figure 83**. The battery in **Figure 83** is simplified to be a current source. The reference value for the current source is based on the frequency measurement and the active power reference value. The variables of interest during the simulations are the frequency of the generators and the load power or the V2G power that is fed back into the grid.

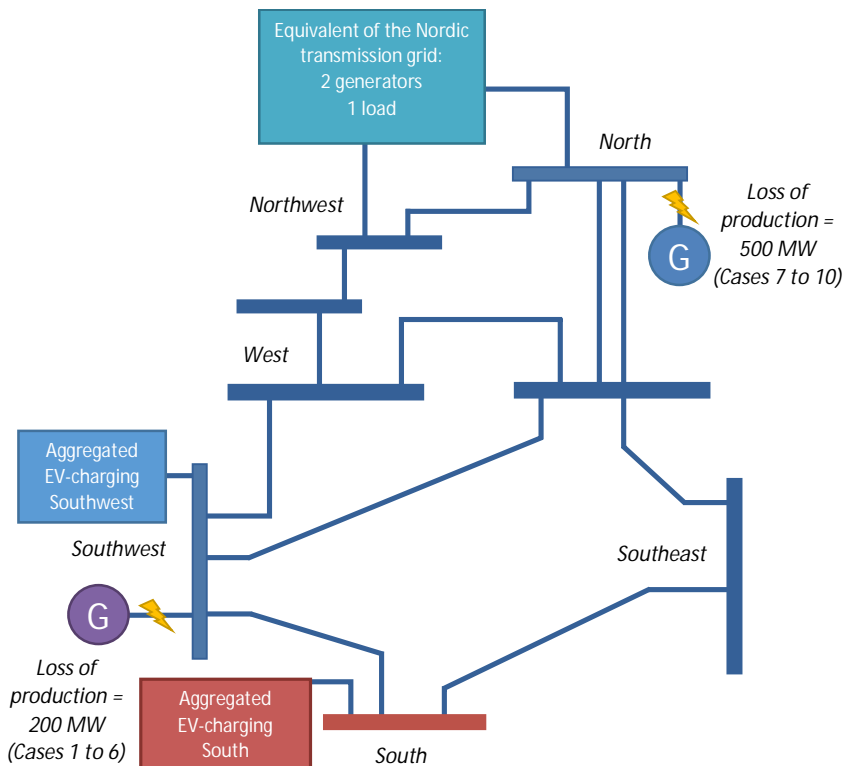

Figure 82. Simplified equivalent of the Finnish transmission system.

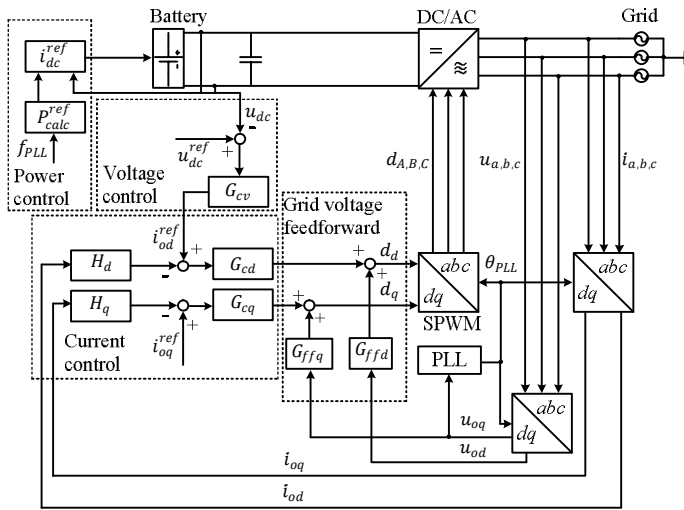

Figure 83. Model of the three-phase converter, based on previous research.^{147,148}

6.2.3 Results

The results from three different cases are presented in **Figure 84**, **Figure 85**, and **Figure 86**, respectively. In the first case, no load is controlled. In the second case, the charging power of the aggregated charger model is controlled in a grid-to-vehicle mode (G2V). In the last case, the aggregated model operates in a V2G mode and the energy is fed back into the grid after the disconnection of a 200 MW generator.

¹⁴⁷ Messo T. Factors Affecting Stable Operation of Grid-Connected Three-Phase Photovoltaic Inverters, Tampere University of Technology, 2014.

¹⁴⁸ Messo T. Dynamic characterization of three-phase inverter in photovoltaic applications, Tampere University of Technology, 2011.

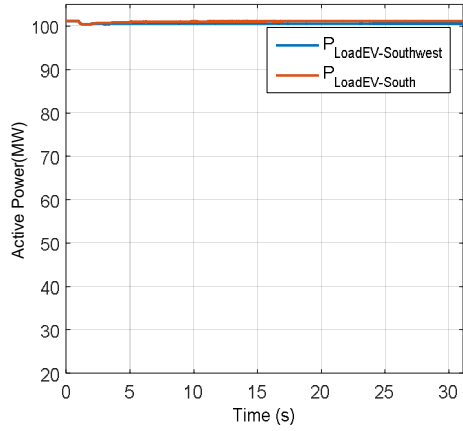
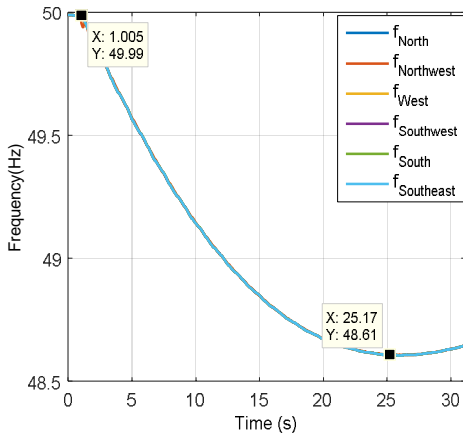

Figure 84. Case 1. Generator frequency and fixed impedance load active power after a disturbance.

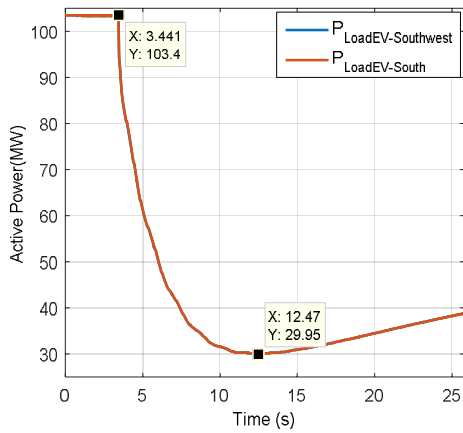
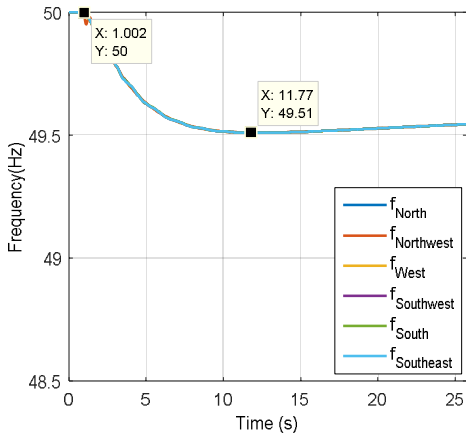

Figure 85. Case 2. Generator frequency and active power taken from the grid after a disturbance.

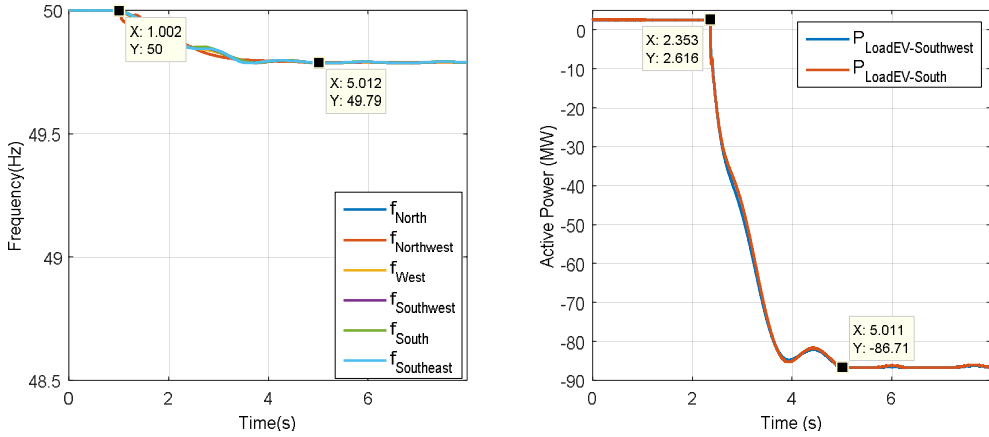

Figure 86. Case 6. Generator frequency and V2G active power taken from the grid after a disturbance with a faster response and increased reserve capacity.

The case studies were implemented by varying the amount of EV FCR-D and the time delay of EV FCR-D. The results from the case studies are shown in **Table 20**. The first case represents a fixed load and the second case a G2V operation with a time delay of 2.4 s before activation. Cases 3 to 6 represent V2G operation where the amount of V2G reserve capacity is varied and the activation time for V2G is altered. Case 7 represents a fixed load but the loss of generation is increased compared to previous cases and case 8 represents the same system with the G2V

Table 20. Summary of case studies by utilised EV FCR, activation time for EV FCR, frequency minimums and time difference until the minimum is reached.

Case	1. Fixed load	2. G2V	3. V2G	4. V2G	5. V2G	6. V2G	7. Fixed load	8. G2V	9. V2G	10. V2G
Loss of generation (MW)	200	200	200	200	200	200	500	500	500	500
Reserve power capacity of G2V/V2G (MW)	0	140	150	170	188	188	0	200	292	372
Activation time for G2V/V2G reserve (s)	-	2.4	1.1	1.15	1.15	1.35	1	1.65	0.85	0.85
Frequency minimum after a disturbance (Hz)	48.61	49.51	49.65	49.73	49.80	49.79	48.23	48.98	49.31	49.61
Time from disturbance until frequency minimum (s)	24.4	11.2	15.0	6.1	4.0	4.0	17.3	13.9	6.9	2.6

power reserve. The effect of increased V2G reserve capacity on the frequency minimum of the system can be seen in cases 9 and 10.

6.2.4 Discussion

If these EV chargers are utilised as an aggregated frequency containment reserve, the frequency minimum is increased as is the duration until the frequency minimum is reduced in the power system when there is a generator disturbance. The frequency dynamics of the system after a disturbance depend on the amount of reserve capacity and the response speed of that capacity. The benefits of reserve capacity from G2V and V2G are apparent from the increased frequency minimums in **Table 20**. The response speed of the aggregated reserve should be faster than the hydropower participating in the frequency control. Even though power system disturbance cannot be forecasted, it is safe to say that V2G has the most potential during the night, as the majority of the EVs and electric buses are connected to the grid and short-term supporting activity does not jeopardise availability for the next day's driving.

In the case of aggregated power electronic systems, the results show that theoretically the fast response time is possible on a power system level. In the studied system, the frequency minimum was below the acceptable levels on fixed load cases. If the charging power and G2V/V2G is utilised as an FCR, it is possible to reach a higher frequency minimum after a disturbance in the studied system. Weaknesses of the studied system are apparent. Other reserves are not modelled and the power system model could be developed further. The electric vehicle charging model and frequency control algorithm for power control could also be improved in future research.

The battery in the studied model was considered to be an ideal current source. However, in reality batteries have both voltage-source and current-source characteristics. Voltage and current vary during the charging and discharging of a battery. The state of charge of the energy storage was not modelled for simplicity but it could be considered in future studies. However, the time duration of the frequency phenomena after a disturbance is short in comparison to changes in the state of charge. A business model for the charging was not considered. Incentives would be needed for the aggregated FCR to be lucrative for investors. The concept of aggregated FCR at a power system level could also be investigated further.

Since the power of a single electric vehicle charger is small on a power system level it would be necessary to have thousands of commercial electric vehicles as an aggregated reserve to meet the current FCR-D reserve capacity requirements set by the Finnish TSO. Battery energy storage systems could also be considered to have similar characteristics as V2G. The topic could be considered relevant from a power quality perspective in distribution systems in future research.

6.2.5 Conclusions

Based on the case studies electric vehicle charging and the V2G mode theoretically has the potential to serve as a power system reserve. However, power system reserves such as load shedding and hydropower generation should still be utilised since loads that are behind power electronics cannot replace the high inertia of hydropower machines.

6.2.6 Acknowledgements

The main author would like to thank Fingrid Oyj for the power system data they provided and Tuomas Rauhala from Fingrid Oyj for giving valuable feedback related to the thesis¹⁴⁹ behind this paper.

6.3 Smart grid integration simulation of electric bus chargers with power quality services and local PV production

Authors: Riku Pasonen, Atte Löff

Affiliations: VTT Technical Research Centre of Finland Ltd

Contact information for main author: riku.pasonen@vtt.fi

Abstract

Simulations on electric bus charging from the power grid perspective were carried out in this study. Transient simulations of charger control were studied with MATLAB Simulink software, both for reactive power control and active power control in respect to line frequency. Control of chargers was possible such that there were no noticeable effects on charging performance, but a meaningful impact could be achieved in terms of grid power quality. In addition to Simulink simulations, correlations between photovoltaic generation and charger load profiles constructed from bus schedules were studied. The conclusion was that PV production could be shifted to morning peak charging power by aligning panels to the East. This was not possible for the afternoon peak as the sun would be already too low in the case simulation. The study shows that there can be mutual benefits in having distributed generation and electric vehicle chargers close to each other from the grid power quality perspective, while if both are separate, it can be demanding in terms of grid connection strength (Fault level).

¹⁴⁹ Lötjönen, M. Electric vehicle charging control as a power system frequency containment reserve, M.Sc. Thesis, Tampere University of Technology, 96 p., 2015.

6.3.1 Introduction

Grid-connected power electronic devices such as electric vehicle chargers can be used in smart grid concepts for power quality management. Without taking account of grid aspects, power electronic loads can be demanding in terms of the power quality. Power electronics can inject high frequency harmonic signals into the power system and cause interference with other devices. Also, without management, the reactive power demand can be high with some devices. Control methods for grid-related power quality services are investigated in this study with a three-phase transient charger simulation model. In addition to this, possibilities for renewable energy integration for a bus depot are studied with a solar model. Solar energy (mainly PV) production can also create power quality problems for the grid. Correlations between the grid effects of PV and electric bus chargers are investigated in terms of voltage sag and overvoltage problems.

6.3.2 Methodology

The electric vehicle charger simulation for the study was made with MATLAB Simulink software with a transient power system calculation. This methodology enabled us to evaluate the power quality aspects in the harmonic spectrum in addition to the voltage level and current calculation. Three charger models were built. One with no reactive power control, one with reactive power injection with respect to voltage measurement, and one with active power control with respect to line frequency.

Interoperability and the correlation between voltage effects and chargers and photovoltaic power generation was analysed with charger load profiles constructed from bus schedules and an hourly simulation of solar production. Bus schedules were available from Helsinki from open data service and solar production was analysed by means of climatological data for the example year.

6.3.2.1 Charger models

A simulation model for a DC fast charger was built to Simulink environment. Model was modified from the Simulink example model for a 250 kW PV model by MathWorks, so as to be a Bidirectional DC charger. The inverter has 700 V DC voltage. The battery and DC/DC converter are not modelled. **Figure 87** represents the main components of the charger model.

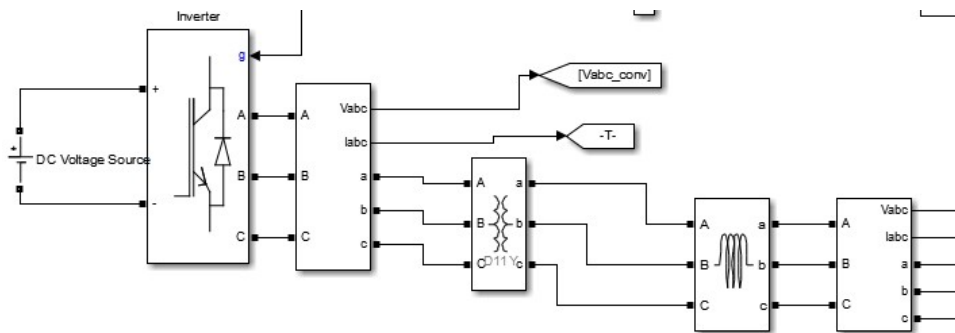

Figure 87. Main simulation blocks of the model.

The converter has a 1:1 ratio isolation transformer. Filtering is done with a simple inductor with 1.45 mH of inductance. Control system components are displayed in **Figure 88**.

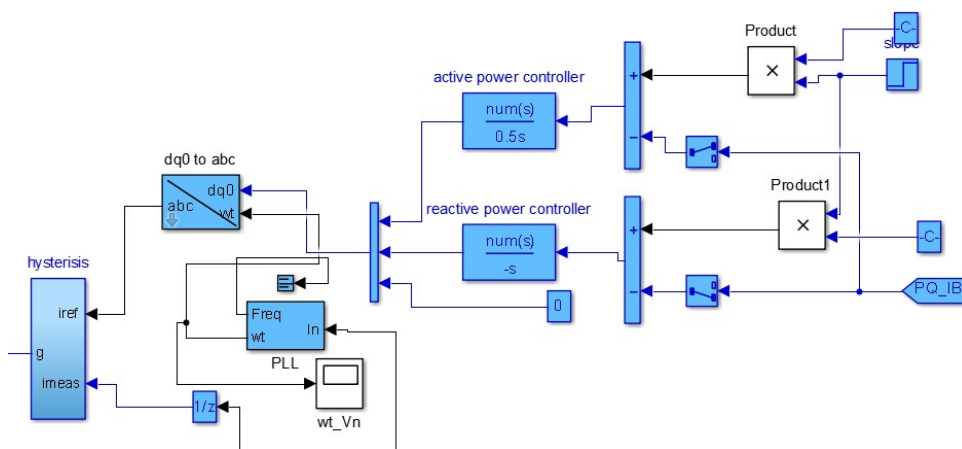

Figure 88. Basic PQ control system.

Control system measures active and reactive power as PU values. The transfer function blocks of Simulink are used as controllers to adjust the d and q components (rotating two-component representation of phase units) and to instantaneous values of phase currents. The hysteresis block of the figure is used to control gate signals to an “on-position” when the current is lower than the reference and to the off-position when the current is higher than the reference. 100 kHz sampling is used for measurement of the phase currents. A delay of 0.1 s is in place before controllers start to raise power to the defined value used. Capture of the current waveform at full power is displayed in **Figure 89**.

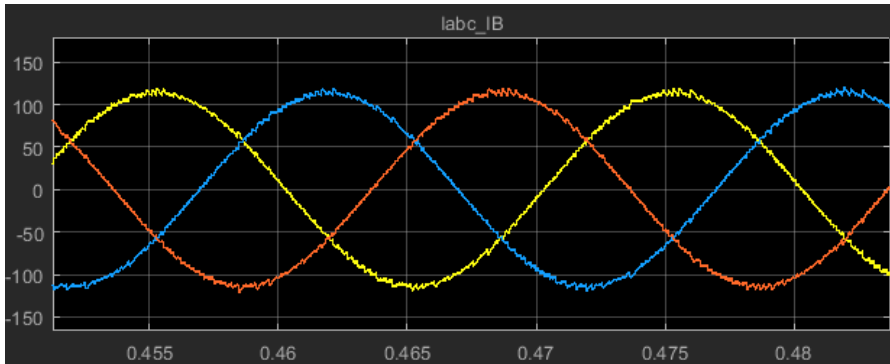

Figure 89. The shape of the current.

THD measurement of the current is displayed in **Figure 90** as a percentage of 50 Hz component.

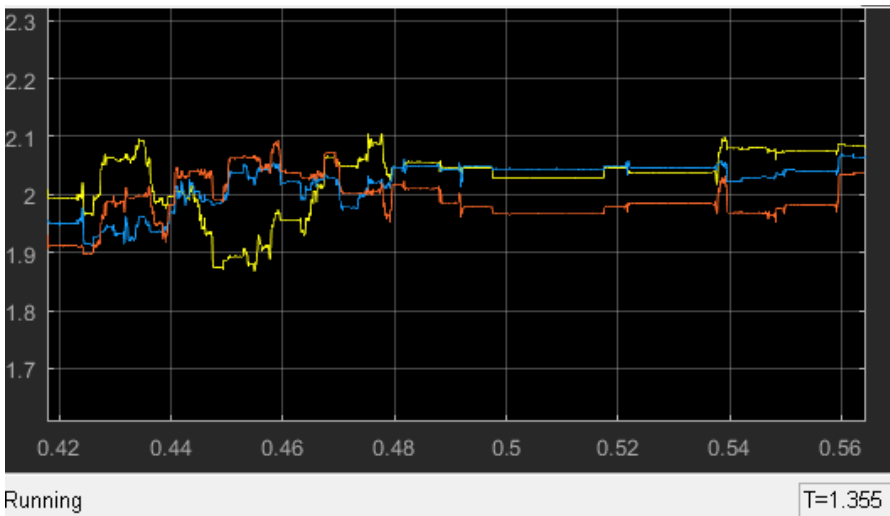

Figure 90. Total harmonic distortion of the current of the charger model.

Total harmonic distortion of the load current of the charger model is about 2% at full charging power. This is similar to measurements reported in the literature (Zimmerman & Bass, 2013)¹⁵⁰ for a 50 kW fast charger for the beginning of charging cycle. Two different charger control methods are presented and compared in the results section.

¹⁵⁰ Zimmerman, N., Bass, R. Impacts of Electric Vehicle Charging on Electric Power Distribution Systems, *Electrical and Computer Engineering Faculty Publications*, **39**, 2013.

6.3.2.2 Solar production simulation

Solar production is modelled for main part with equations introduced by Duffie & Beckman 2013. Solar radiation in the model is divided into three components. Direct sunlight, diffuse sunlight and reflected sunlight. These components are illustrated in **Figure 91**.

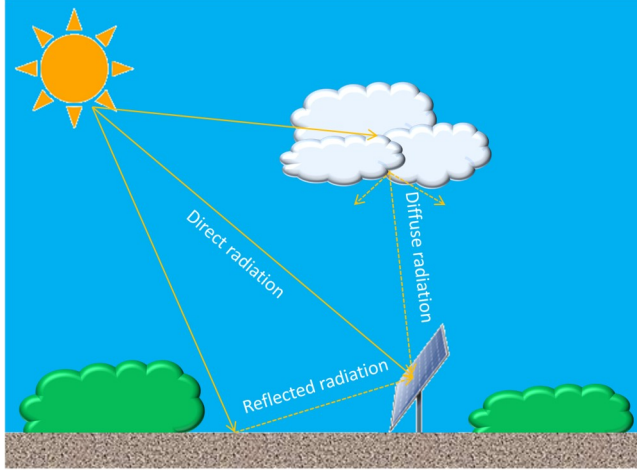

Figure 91. Components of solar radiation to surface of tilted solar panel.

Direct sunlight comes straight as a beam from the sun. The diffuse component is indirect light (soft light) and its intensity is not direction dependent. Reflected radiation is direction dependent but does not come straight from the sun. Calculation of the radiation on a tilted panel surface was done with the HDKR model (Hay, Davies, Klucher, Reindl model) (Duffie & Beckman, 2013).¹⁵¹ The total radiation on a tilted panel surface is,

$$I_T = (I_b - I_d A_i) R_b + I_d (1 - A_i) \left(\frac{1 + \cos \beta}{2} \right) \left[1 + f \sin^3 \left(\frac{\beta}{2} \right) \right] + I_{\rho_g} \left(\frac{1 - \cos \beta}{2} \right) \quad (16)$$

where I_T is the total radiation on the tilted surface, I_b is the beam radiation, I_d is the diffuse radiation, I_{ρ_g} is the ground reflectance (also called the albedo), R_b is the ratio of beam radiation on the tilted surface to the beam radiation on the horizontal surface, A_i is the anisotropy index, β is the slope surface and f is the final factor. The anisotropy index determines a portion of the horizontal diffuse component and it is given by the following equation (Duffie & Beckman, 2013):

$$A_i = \frac{I_b}{I_0} \quad (17)$$

¹⁵¹ Duffie, J., Beckman, W.A. Solar Engineering of Thermal Processes 4th edition, Wiley, 2013.

I_0 is the extra-terrestrial horizontal radiation. The value of extra-terrestrial radiation depends on time and date (direction of the sun). The final factor is related to the cloudiness of the location and it is given by the following equation (Duffie & Beckman, 2013)¹⁵¹:

$$f = \sqrt{\frac{I_b}{I}} \quad (18)$$

where I is the global horizontal radiation on the surface of the earth. Total radiation on the tilted panel surface is utilised in PV panel temperature calculations with the following equation (Honsberg & Bowden, 2013)¹⁵²:

$$T_{module} = T_a + \frac{NOCT - 20}{80} \cdot I_T \quad (19)$$

where T_{module} is panel temperature, T_a is the ambient temperature, $NOCT$ is the Nominal Operating Cell Temperature (between 33-58 °C, typically 48 °C). Finally, the PV system production estimation can be calculated with following equation:

$$P_{module} = P_n \cdot f_D \cdot \frac{I_T}{I_{T,STC}} \cdot (1 + k_T \cdot (T_{module} - T_n)) \quad (20)$$

where, P_{module} is the power production estimation, P_n is the nominal power under standard test conditions, $I_{T,STC}$ is the nominal radiation in standard test conditions, f_D is the derating factor, T_n the panel temperature in standard test conditions, and k_T is the temperature-dependant performance factor (negative in value).

6.3.2.3 Load profile generation from bus schedules

The Tapiola bus terminal was selected as the case location. **Figure 92** shows the bus terminal area.

¹⁵² Honsberg, C., Bowden, S. *Photovoltaic Education Network*. December 2013. Retrieved from PVEDucation: <http://pveducation.org/>.

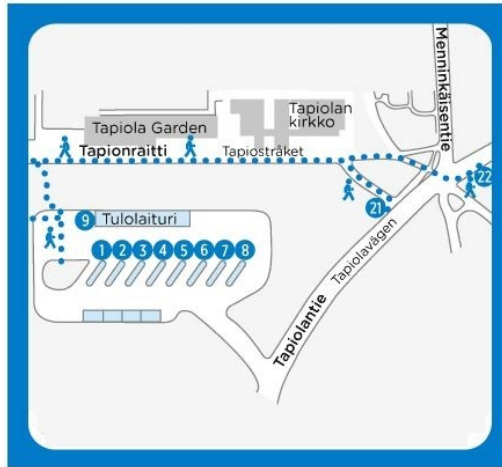

Figure 92. Tapiola bus platform. (HSL, 2015)¹⁵³ Helsinki Regional Transport HSL website.

The timetable for the Tapiola bus platform was obtained from Helsinki Region Transport (HSL)¹⁵³ open data service and the timetable was utilised to create a daily charging profile for the bus routes. A one-minute time step was used in this study and the idea is that each bus departing from the platform is charged for five minutes before the departure time. **Figure 93** shows the charging profile for the whole bus

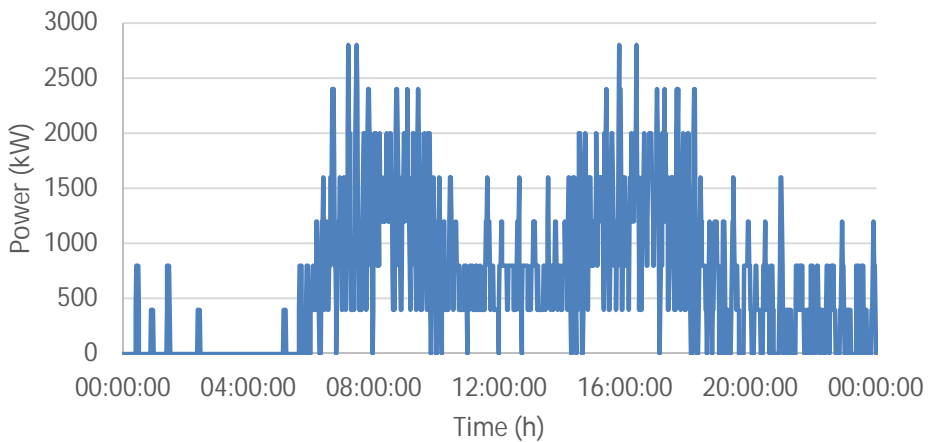

Figure 93. Charging profile of the Tapiola bus platform during a weekday.

¹⁵³ HSL. *Helsinki Region Transport HSL website*. Helsinki Region Transport HSL. 2015.

platform during a weekday. The maximum charging power during the weekday is almost 3.0 MW. The highest number of chargers charging at the same time is seven and this is around 7 am and 4 pm, which are regular times for working people to use the buses.

6.3.3 Results

6.3.3.1 Charger control methods for power quality management

The idea in control methods for grid power quality management is that a meaningful impact can be achieved without noticeable interference in the charger's daily operation or performance. The simulation is run with voltage-dependent reactive power control, line frequency dependent active power control, and without those controls for base simulation. There are eight 50 kW chargers in the simulation. **Figure 94** shows the simulation model in Simulink.

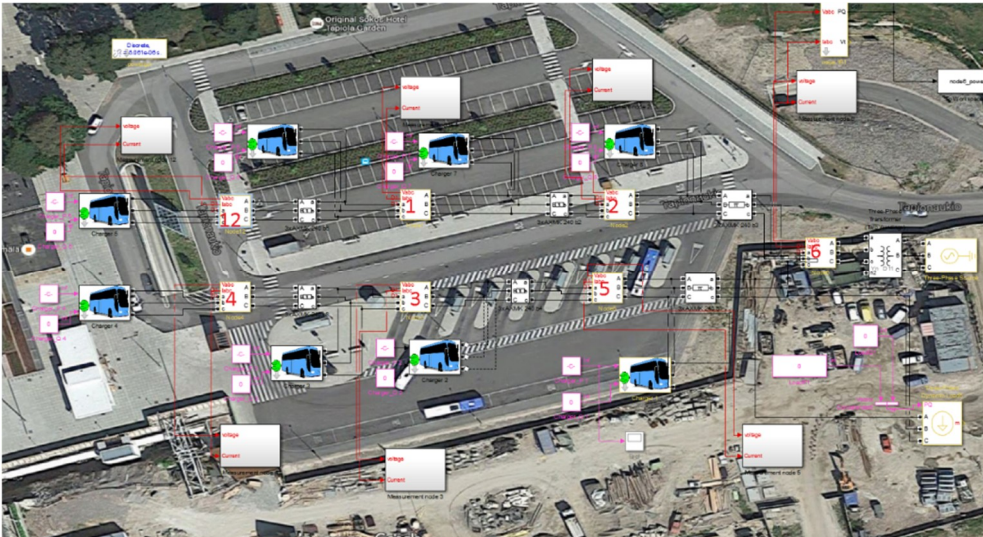

Figure 94. Simulation model for the case area.

Power measurement in the simulation at distribution transformer is presented in **Figure 95**.

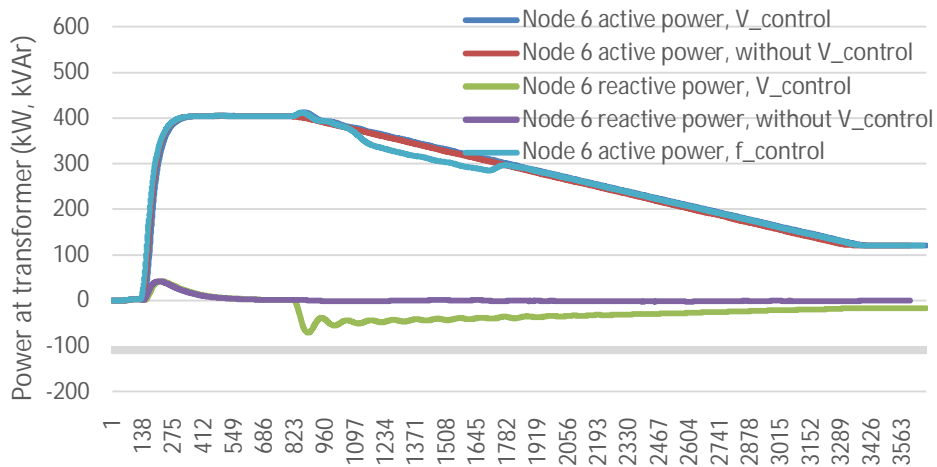

Figure 95. Active and reactive power measurement at the transformer in the simulation.

Active power is sloped down after some time to simulate the effect of decreasing power demand of the charger when battery is approaching full charge. Around the timestamp 862, reactive power control is possible when the apparent power limit and lower active power allow it. The reactive power droop is quite steep so that full reactive power is in use when the voltage difference is 2.5% from nominal. The figure also has active power simulated with frequency control with -40%/Hz after the line frequency is under 49.8 Hz. The simulated frequency sag was 49.6 Hz (from 50 Hz). **Figure 96** displays voltage measurements in the simulation.

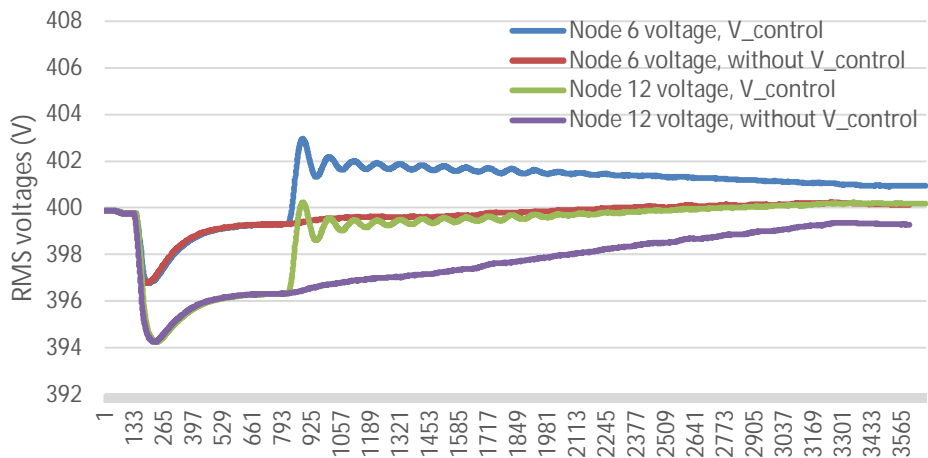

Figure 96. Voltage RMS measurements in the simulation.

Node 6 is at the transformer and node 12 at the end of the upper feeder. We can see that the voltage drop is corrected at the end of the line, but the voltage at the transformer rises a bit over the nominal. The harmonics in voltage are displayed in **Figure 97**.

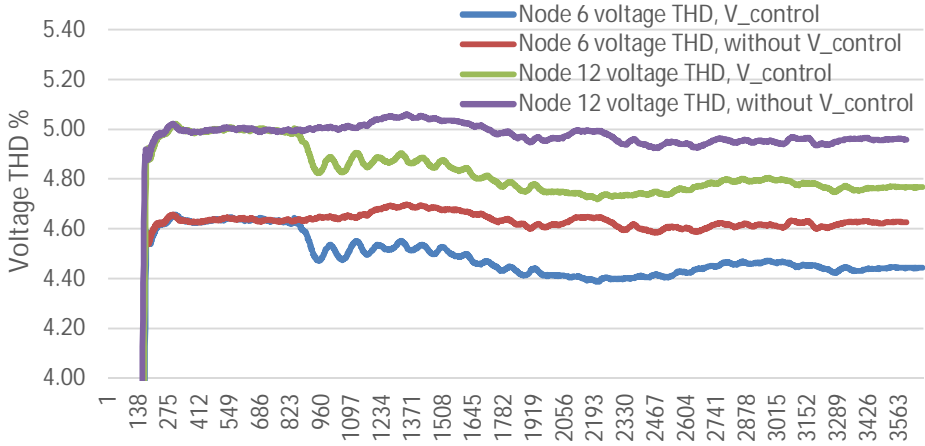

Figure 97. Voltage harmonics.

Voltage control reduces the total harmonic distortion somewhat, but the effect is quite small, **Figure 98**.

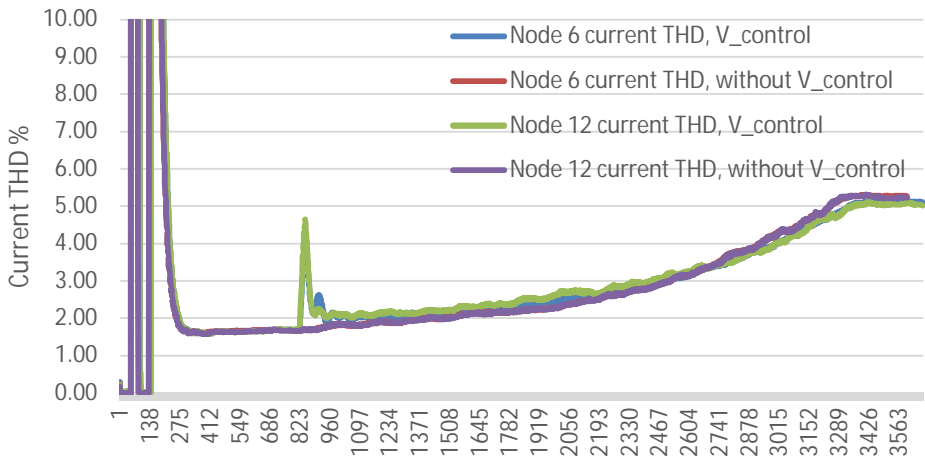

Figure 98. Total harmonic distortion of current.

The harmonics of the current are quite the same in both simulations. Filtering works best at full power and THD increases when power is lower.

6.3.3.2 Solar energy integration study for electric vehicle depot charging

Here the correlation of the bus schedule from Tapiola with the solar power simulation hourly curve is considered. The purpose is to study how PV solar generation would fit to the location in terms of power grid stress and possibly creating savings when electricity is produced locally. **Figure 99** displays the power output curve of the PV panel calculated from 1998 solar data published by NASA. (NASA, 2014)¹⁵⁴

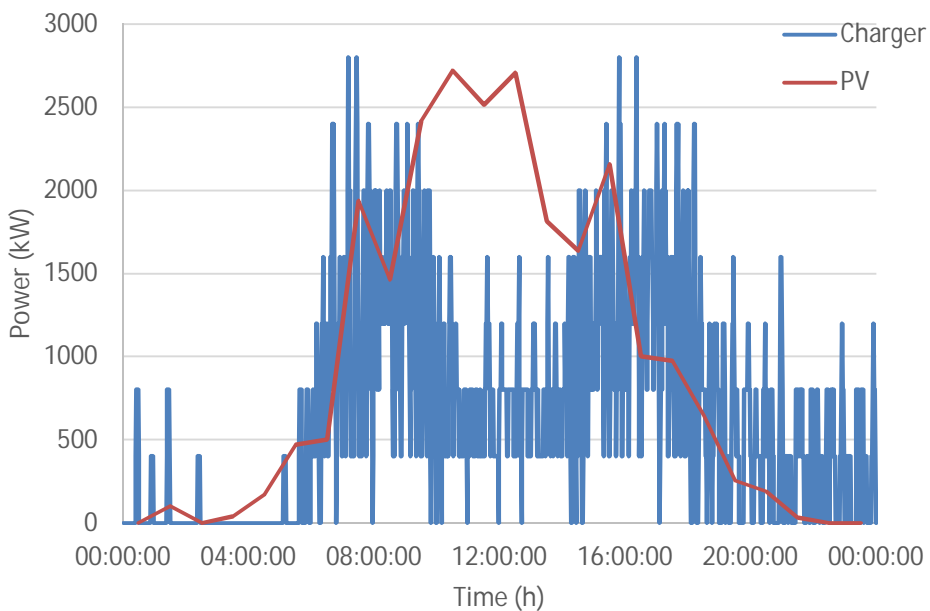

Figure 99. Charger power demand and PV curve.

It can be seen from **Figure 99** that the charger load profile has two peaks while the PV curve peaks at midday. Ideally, we would like the curves to match better but the local grid could benefit from PV at the charger vicinity if reactive power control in PV inverters is used to reduce the voltage sag even if the sun is not shining. The positioning of the solar panels affects the curve. **Figure 100** displays the PV curves of the panels installed towards the east and west.

¹⁵⁴ NASA. *NASA Surface meteorology and Solar Energy*. 2014. Retrieved from <https://eosweb.larc.nasa.gov/sse/>

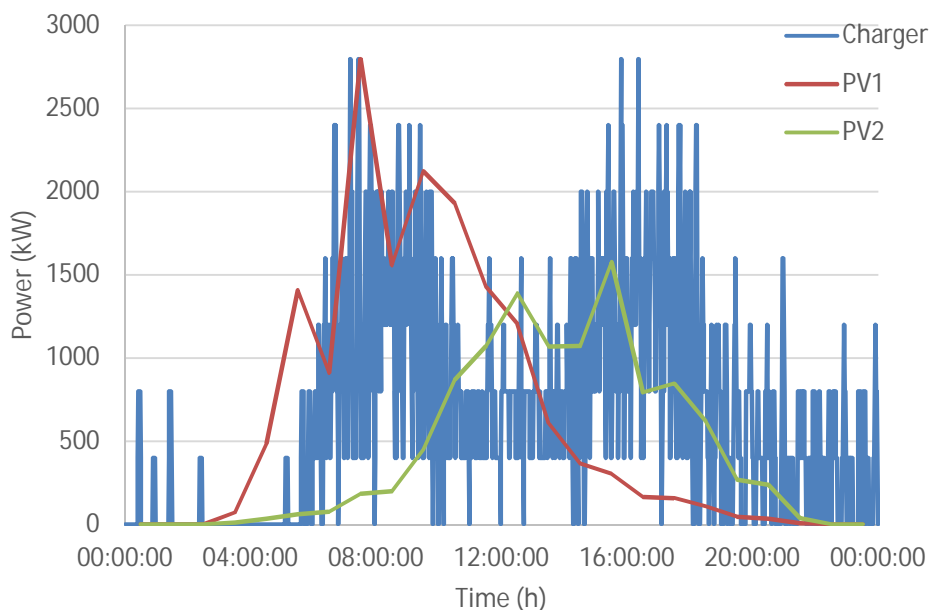

Figure 100. PV panels aligned to east (the red line) and west (the green line).

The east curve fits quite nicely to the morning peak of the charger curve, but the west-facing panel has much more difficulty in producing a similar peak in the afternoon.

6.3.4 Discussion

Simulations of electric bus charging from a power grid perspective were carried out in this study. Charger simulations were done with MATLAB Simulink software to investigate the effect on power quality by means of a transient model. Smart charger functionality was simulated so that the charger had a way to control reactive power and therefore grid voltage when the charger was not operating at full active power capacity, and also to react to line frequency changes. Reactive power control of electric vehicle chargers have been investigated by (Kisacikoglu;Ozpineci;& Tolbert, 2010)¹⁵⁵ who found that reactive power injection can be done without effects on the battery or charging. Although reactive power injection is not possible when the charging power is at maximum and when the grid needs it the most, staging chargers to start at different times could be beneficial. The charger uses full power only at the beginning of charging cycle. Therefore, reactive power control is possible

¹⁵⁵ Kisacikoglu, M., Ozpineci, B., Tolbert, L. Effects of V2G Reactive Power Compensation on the Component selection in an EV or PHEV Bidirectional Charger, Energy Conversion Congress and Exposition (ECCE), 2010 IEEE, pp. 870–876, Atlanta: IEEE. 2010.

to a different degree for most of the charging. Active power control in respect to line frequency is included into a newer standard for grid-connected power electronics production devices such as small-scale PV generators. It is fair to assume that similar demands will be included in larger power electronic load standards when they become a larger factor in power grids.

Photovoltaic generation's correlation with charger schedules was studied with a simplistic method for comparing load and generation curves. To better understand the interoperability possibilities of PV (or any distributed energy source), transient modelling of the interaction from a power quality perspective would be required. The idea is that as the power output of both changes over time and both can create problems in the voltage levels, while also controlling reactive power to mitigate it. Therefore, there is the obvious possibility for both to benefit from each other from a grid power quality perspective.

6.3.5 Conclusions

A smart control functionality can be integrated into electric vehicle chargers without notable changes in the day-to-day operation of electric vehicle chargers. Both reactive power control and active power control in respect of frequency are possible with bidirectional chargers. A voltage control droop with reactive power was implemented in the Simulink model. This control method was selected since it should fit well to the different grid environments, in contrast to, for example, using constant ratios for reactive power and active power. Also, this method makes it possible to mitigate voltage level problems caused by other sources than electric vehicle chargers. A small resonant voltage fluctuation occurred in the simulation due to cross control of chargers as a negative effect.

Another source of voltage problems is distributed generation sources such as PV panels. The correlation of PV power production with the charger load profile was studied with an example bus schedule. A difference found was that bus charging done according to the schedule showed two peaks in the profile (one peak in the morning and another in the afternoon), while PV generation has one peak that is usually at midday. To study the possibility of lining up the curves, the panels were simulated as pointing to the east and to the west. Following this, the morning moved over the charging peak. When the panels were directed to the west, there was less success in producing the afternoon charger profile because the sun was already too low. Although the PV power curve can be adjusted to better match the load and the power production, a year-round analysis would be needed in addition to this theoretical study of a random day. Such an analysis utilising long-term data could lead to multidisciplinary results on how distributed generation would best serve future energy systems, while taking account of large loads such as with electric bus charging stations.

6.4 Electric vehicles in electricity grids

Authors: Antti Rautiainen, Pertti Järventausta
Affiliations: Tampere University of Technology
Contact information for main author: antti.rautiainen@tut.fi

Abstract

Electric vehicles (EVs) offer a new, or historically speaking a retro type, tool to decrease CO₂ and air quality related emissions, reduce oil dependency and even to improve operation of the electric power system. Over the past few years, almost all big car manufacturers and also some new players have brought different types of EVs to market. A 'smart' electrical energy system of the future includes the flexibility of electricity demand, i.e. demand response (DR), enabled by different types of incentives and offering many potential advantages. This paper discusses electric vehicles and the flexibility of other loads and other resources in a smart grid context. In order to achieve effective and financially efficient DR operation of small resources, a holistic approach should be taken. The possible 'threats' caused by EVs to the electricity system and also the possible advantages of EVs to the system should be taken into account as a whole together with the possible conflicts of interest between electricity market actors. In addition, one should also take other distributed energy resources besides EVs into account. Only in this way can reasonable incentives and the desired results be achieved.

6.4.1 Introduction

Electric vehicles (EVs) offer a new, or historically speaking a retro type¹⁵⁶ tool to decrease CO₂ and air quality related emissions, reduce oil dependency and even to improve operation of the electric power system. Over the past few years, almost all big car manufacturers have brought different types of EVs to market, and some new players like Tesla Motors have achieved significant momentum in the EV business. Perhaps the greatest barrier to the widespread penetration of EV's currently is their high prices. It is likely, however, that prices will go down over the course of the following years.

EV's are a new type of load in electricity networks. The EV charging loads have different impacts in different types of networks, such as transmission networks, distribution networks and networks of real estates. Also, the impacts depend on whether the charging is 'controlled' or 'uncontrolled'. A smart electrical energy system of the future includes flexibility regarding electricity demand, i.e. demand response (DR), enabled through different types of incentives and offering many potential advantages. EV's could also participate in DR markets alongside other resources.

¹⁵⁶ Burton, N. A History of Electric Cars, The Crowood Press Ltd, 224 p., 2013.

This paper discusses electric vehicles and demand response in a smart grid context. In order to achieve an effective and financially efficient DR operation of small resources, a holistic approach should be taken. The possible ‘threats’ caused by EVs to the electricity system and also the possible advantages of EVs to the system alongside other distributed energy resources (DER) should be taken into account as a whole. Other distributed energy resources can include controllable loads, energy storages or distributed generation. An intelligent integration of EV’s and other small DERs (controllable loads, distributed generation, energy storages) to the electricity grid enables efficient operation of the resources, which further could lead to financial efficiency and/or improved operation of the whole electrical energy system. This paper’s author strongly argues that only with a holistic approach can the desired results be achieved. A carefully considered framework would enable an efficient operational environment for companies and other actors developing new businesses.

In the following sections, the threats and opportunities of EV’s are described and some essential aspects that are related to achieving an efficient holistic system are discussed. Finally, some conclusions are made.

6.4.2 Threats and opportunities of EV’s in regard to the electricity system

There are different electricity system related actors who might be affected by a large penetration level of EV’s. The main actors are

- Electricity retailers
- Distribution system operators
- Transmission system operators

The actors often have different interests regarding how consumption and/or distributed generation should operate. **Table 21** presents some of the threats and opportunities posed by EVs and other DERs for the different actors in the present

Table 21. Threats and opportunities posed by EV’s and other DERs for different actors of the electricity system.

Actor	Threat	Opportunity
Electricity retailers	Unpredictable variations in consumption which increases the financial risks in the electricity market	Controllable DERs as resources for demand response resources in the electricity market
Distribution system operators	Increased peak loads	Controllable DERs could offer new tools for network management
Transmission system operator	Increase (and especially an unpredictable increase) in national electricity (peak) demand	Controllable DERs could offer new resources in power system reserves, demand response resources in the electricity market

North-European power system and electricity market. When discussing ancillary services of EVs, it is reasonable to think all the flexible resources together with EVs. In some cases such as discussing charging service operators' business, concentrating only to EVs might be reasonable.

An electricity retailer has to estimate the consumption of its customers every hour in order to purchase the right amount of energy, typically from the *Elspot* day-ahead market in Nordic countries. If the consumption estimate is too low compared to the realised consumption, the retailer must buy the difference from the balance market, and if the consumption estimate is too high, the retailer has to sell the surplus energy to the balance market. In both cases, the retailer may suffer a monetary loss compared to the situation where the consumption estimate would match the real consumption. These monetary losses can eventually be quite high. If the retailer had price-sensitive customers with electricity retail prices directly bound to *Elspot* prices and if the retailer could forecast how consumers react to different prices, the retailer could take this into account in its bids. This would help the retailer to manage its own balance and if this kind of electricity demand price responsiveness would be applied broadly, it could lower the general price level in the power exchange. Using a direct load control possibility, the retailer could also manage its balance very close to the physical delivery hour. The potential benefits of DR in electricity trading in the long run depend on many things, such as the capability to estimate consumption and customer behaviour on the part of the retailer and the means and level of hedging of the procurement. Electric vehicles and other DERs would pose a threat to retailers by increasing the uncertainty of the electricity demand. However, retailers in the long run could learn to forecast the changes in the load and small-scale production and thus decrease uncertainty. On the other hand, EVs and other controllable DERs offer a tool to be used as a flexible resource in the electricity market.

Distribution system operators (DSOs) are responsible for planning, building, maintaining and operating the local distribution networks, which are further connected to the national transmission grid. In general, the holistic societal target is to minimise electricity infrastructure costs within certain boundary conditions, such as safety and the level of service. In general, the aim of the distribution system planning tasks can be presented as the following minimisation task:

$$\min \sum_{t=1}^T (C_{inv}(t) + C_{loss}(t) + C_{out}(t) + C_{maint}(t)), \quad (21)$$

where C_{inv} , C_{loss} , C_{out} and C_{maint} represent the present values of investment, loss, outage and maintenance costs, respectively, of the years (1, 2, ..., T) of the planning horizon.¹⁵⁷ Electric vehicles and other DERs could increase the peak loads in the networks and thus increase the investment costs. Studies related to the impacts of EV charging load to distribution networks show¹⁵⁸ that with a moderate number of

¹⁵⁷ Lakervi, E., Partanen, J. Sähköjälkelutetekniikka, Otatiето. 285 p., 2008. (in Finnish)

¹⁵⁸ Rautiainen, A. Aspects of Electric Vehicles and Demand Response in Electricity Grids, Doctoral dissertation, 79 p. + publications, 2015.

EV's with moderate charging power, the impact of charging on peak loads of electricity network is modest. However, there are certain situations where EV charging loads might become significant. One such possible scenario is when people start using high-power chargers in their homes. This case is especially relevant if full EVs (i.e. battery EVs) increase significantly, since full EVs can have very large battery packs and the charging needs can occasionally be very high. A possible scenario arising from large penetration of full EV's is that people purchase charging stations that would be able to use the whole capacity of the network connection for the network customers.¹⁵⁹ A simple example of this is illustrated in **Figure 101**, where a real LV network of a Finnish DSO is presented. The network includes one distribution transformer and six network customers. The customers are classified as detached houses with no electric heating and no electric sauna stoves. However, all the network customers have 3×25 A network connections. If all six customers bought full EVs and charged them simultaneously (this is a realistic scenario as the number of customers is small) using a three-phase charger that would enable the use of the highest possible charging current limited by the capacity of the network connection (3×25 A), the total peak load of the 30 kW distribution transformer could be up to 3×230 V \times 25 A \times 6 = 103.5 kW. This is of course an extreme case, but a realistic one if the number of EVs would be high. One problematic situation would arise if all six EV's would use one-phase chargers and the chargers would be connected to the same phase of the network (this is a realistic scenario, too, due to the small number of customers). In such a scenario, the transformer would be exposed to a highly unsymmetrical overload. However, EV's and other controllable DERs could also bring new types of opportunities for a DSO to apply demand response or other flexibility of the DERs in the operation of the distribution system.

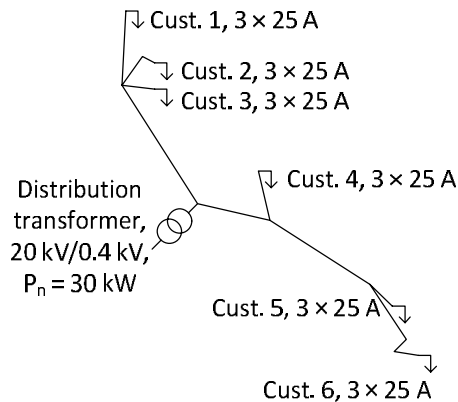

Figure 101. Example network.

¹⁵⁹ Rautiainen, A., Järventausta, P., Tikka, V. Lana, A. Control of Electric Vehicle Charging in Domestic Real Estates as Part of Demand Response Functionality, Submitted to Cired Workshop 2016 conference, 4 p.

The third actor that EV's might influence is the TSO. Three essential tasks of a TSO, especially in the Nordic countries, are to operate the transmission system, ensure the reliability of the power system and promote the operation of the electricity market. If there were large numbers of EV's that were charged in a 'dumb' way, it might increase the national electricity demand peak, which could increase the risk of a power shortage. Implementing the flexibility of EV's and other controllable DERs in the form of e.g. DR would potentially help the TSO in its operations. It is in the interests of TSOs if DR or other flexibility can be applied in different types of reserve markets as well as the wholesale electricity market. In principle, the Finnish TSO Fingrid enables the use of distributed DERs in its reserve markets although the present market lacks clear predefined rules on how the distributed DERs would be controlled and how their proper operation would be verified.

6.4.3 Towards an efficient holistic system

The threats and opportunities posed to different actors by EV's and other controllable DERs have been described and discussed above. In this paper, a customer centric model is considered. This means that different actors offer electricity consumers different kinds of products and services, and the customer would make decisions directly or via an 'energy management service' on how its DERs would be used. In the foreseeable future, there will also be some conflicts of interest between different actors if EV's and other controllable DERs were to be deeply integrated into the electrical energy system. **Table 22** presents some conflicts of interests between different actors. Different solutions to the conflicts of interests can be found, but some work better than others do. In the following, some solutions are discussed.

Table 22. Conflicts of interests between different actors.

Actors	Conflicts of interests
Electricity retailer + DSO	Via the hourly varying pricing, the retailer encourages customers to concentrate electricity demand at low price times, which would possibly increase the peak loads in the distribution networks. ¹⁶⁰ DSO could use DERs for the purposes of the distribution network operation, and this could cause financial risks to the retailer in the form of increased uncertainty in the managing the consumption balance.
TSO + Electricity retailer	TSO would like to use the flexibility of DERs in the operation of the power system for example in the form of reserves, but this would pose financial risk to the retailer in the balance market. The retailer would also like to use the flexibility of the resources in wholesale electricity markets.
DSO + TSO	DSOs would like to have low peak power in the distribution networks, but the use of the DERs' flexibility might increase the peak power.

¹⁶⁰ Rautiainen, A. Aspects of Electric Vehicles and Demand Response in Electricity Grids, Doctoral dissertation, 79 p. + publications, 2015.

The problem for DSOs is often that some non-DSO actors' (including network customers) actions would increase the peak power of the network and thus decrease the utilisation rate of the network and further lead to financial inefficiency. One possible solution to this would be that DSOs would change the distribution-pricing paradigm in a more power/peak power intensive direction. This could mean that customers would pay distribution fees in accordance with the power/peak power that they actually use rather than a fixed non-power related charge or based on the amount of consumed energy. This would encourage customers and further different service/product producers to consider the power demand of the customers. If the power-based distribution pricing were made in a smart way, it is possible that retailers and the TSO could still use the flexibility of the DERs without raising the peak powers in the network (considerably). Power based distribution pricing would also encourage customers to charge their EVs in a way that would not increase the peak loads in the network as presented earlier in the paper.

A general problem for electricity retailers is that if a non-retailer actor would use the flexibility of EV's and other DERs, this would pose a financial risk to the retailer in terms of imbalance in the wholesale market. One solution candidate for this could be some kind of a system for information exchange. This means that when a non-retailer actor would make a 'flexibility contract' with a customer and/or if the non-retailer actor would send/carry out real control commands/actions, this information would be delivered immediately to the retailer too. This means that the retailer could take the control actions into account in its operation as well as possible. In some cases, like using DERs to operate as TSO's reserves, the physical control actions would be carried out within a very short time after the appearance of the need for the control action. In such cases, the retailer has no time to react to these actions. Another approach¹⁶¹ could be that retailers would get some kind of a straight financial compensation from the non-retailer actors in cases where the non-retailer actors would carry out physical control actions. Nevertheless, in all cases it should be ensured that the non-retailer actors cannot pose a threat of significant imbalances for the retailers. All the solution candidates should be investigated in more detail and discussed broadly among different actors and tested with pilot field tests.

6.4.4 Conclusions

EVs and their control with other DERs pose different threats and opportunities for different actors in the electricity market. The threats could be managed and the opportunities could be realised, at least partly, simultaneously through reasonable market structures and rules. These things should be investigated and a wide discussion should be held among regulator and market actors to arrive at a consistent system that maximises the holistic benefit of the whole electrical energy system.

¹⁶¹ SEDC 2014. Mapping Demand Response in Europe Today, Tracking Compliance with Article 15.8 of the Energy Efficiency Directive. SEDC – Smart Energy Demand Coalition. 93 p.

6.5 Modelling of grid-friendly charger topologies for electric vehicles

Authors: Aushiq Ali Memon, Kimmo Kauhaniemi

Affiliations: University of Vaasa

Contact information for main author: aushiq.memon@uva.fi

Abstract

The interest in electric vehicles (EV's) has increased both in passenger transportation and in industrial applications. A core component of electric vehicles is the battery used for storing the energy. In some applications, the bidirectional power flow is also expected to be useful. Various technical solutions exist to accomplish a suitable interface for exchanging power between the battery and the grid. The drawbacks of very simple and cheap battery chargers include possible adverse effects on the electric-grid such as harmonics, non-sinusoidal flow of current and a low power factor, as well as typically relatively low efficiency. Better performance can be achieved with some advanced charger topologies, although this usually leads to a larger number of active components and a more complex control scheme. There are several possible topologies for chargers and these are briefly introduced in this paper. The main contribution of this study is the development of performance testing of the simulation models for grid-friendly charger topologies. Considering the EV's application areas, this paper is based on technologies applied in passenger cars, although the solutions are also viable and scalable to various commercial applications.

6.5.1 Introduction

According to technical solutions, EV chargers can be classified as illustrated in **Figure 102**. This classification originates primarily from the solutions developed for passenger cars, but it can be applied also to commercial vehicles. In practice, the charging system that enables the power flow between the grid and battery consists of the following parts:

- Electric grid interfaces (filters, relays etc.)
- AC/DC conversion (controlled/uncontrolled, unidirectional/bidirectional)
- DC link
- DC/DC conversion (Buck/Boost-control, isolation)
- Battery interface (filters, battery management system etc.)

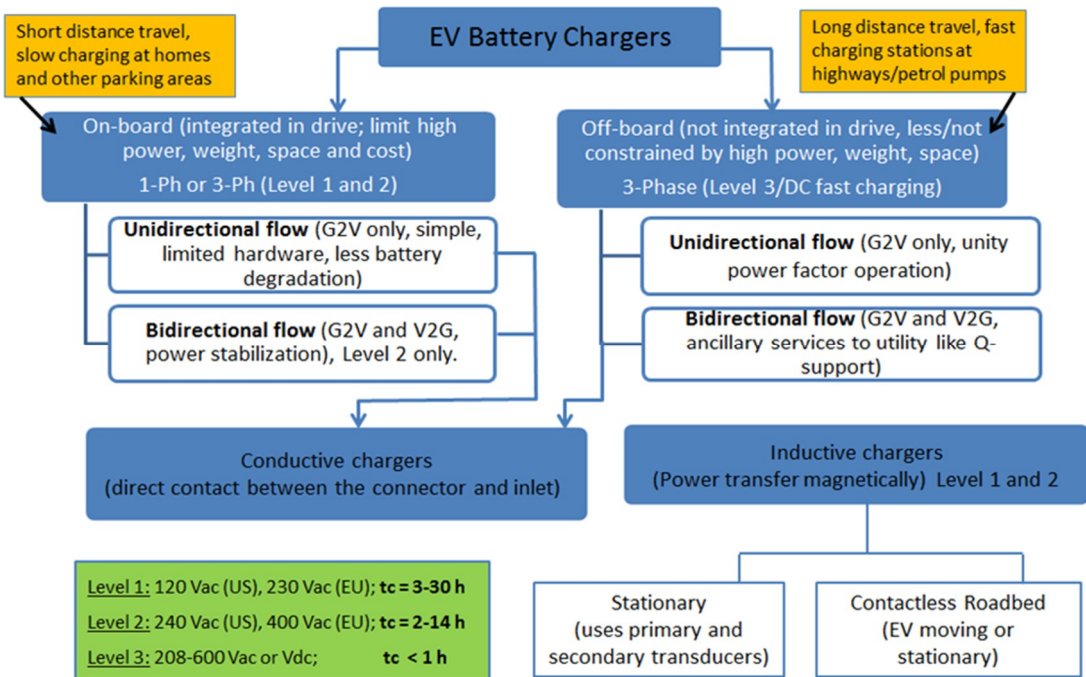

Figure 102. Classification of EV chargers.

A key design feature is whether the charger is on-board or off-board. Naturally, an off-board charger means savings in the vehicle weight. Considering the whole charging system the placement of individual parts (on- or off-board) may also have a design aspect especially in commercial electric vehicles.

Although the primary use of chargers is to charge the vehicle battery, the discharging of the battery to the grid (V2G, vehicle to grid) also provides an interesting operational option especially in the Smart Grid environment. The term Smart Grid refers to the modernised electric grid that intelligently integrates electric generators (renewable/non-renewable) and consumers and coordinates their actions in order to supply sustainable, efficient, economic and reliable power supply. The Smart Grid, with the help of intelligent monitoring, control, communication and self-healing technologies, not only enables the consumers to play an active part in the operational optimisation of the system, but it also provides consumers with detailed information and a choice of supply. In such an environment, the electric vehicle can be considered as mobile energy storage.

There are specific requirements for the charging system originating in the area of application, battery characteristics and grid connection capabilities etc. This paper focuses on the requirements related to the grid interface. Generally, the charging

system should meet the power quality requirements while maintaining good efficiency. Thus, in this study the main aim has been to develop simulation models for typical grid-friendly chargers.

Three types of EV charging with different power levels have been introduced in various standards for EVs/PHEVs. They are usually named as Level-1, Level-2 and Level-3 charging in USA while in Europe the corresponding levels are referred to as Mode 2, Mode 3 and Mode 4. It is worth noting here that the terms Level-1, Level-2 and Level-3 only refer to slow, medium-fast (semi-fast) and fast charging of electric vehicles depending on supply voltages and power capacities and are not related in any way to types of power electronic converters (for example, two-level and three-level PWM converters etc.). The voltage, current and power ratings for three levels of EV charging for the USA and EU^{162,163} are given in **Table 23**. The chargers for level-1 and level-2 are more likely to be independently assembled on-board chargers, which can also be integrated with the electric drives of EV's (so-called integrated chargers) in order to avoid the problems of weight, space and cost.^{162,164} The charging of power level-3 is intended for commercial and public applications such as when operating as a filling station and when the chargers are only installed off-board the EV's.

The modern EV chargers usually include power factor correction (PFC) AC-DC front-ends, preferably with boost PFC in continuous conduction mode, in order to avoid adverse impacts on electric-grid and to comply with national/international standards like IEC 1000-3-2 (EN 61000-3-2), IEEE 519, IEEE 1547, VDE etc. The PFC AC-DC front-ends not only result in a unity power factor, lower harmonic distortion of power supply, higher efficiency and low ripple in output DC voltage but their closed-loop control gives a well-regulated DC output voltages over a wide

Table 23. Typical voltage, current and power ratings for different EV charging levels.

	USA			EU		
Level-1	120 Vac	16 A	1.92 kW	230 Vac	16/20/32 A	3.68/4.6/7.4 kW
Level-2	240 Vac	17/32/80 A	4/8/19.2 kW	400 Vac	16/32/63 A	11/22/44 kW
Level-3	208–600 Vac or Vdc, 50–240 kW					

¹⁶² Yilmaz, M., Krein, P.T. Review of Battery Charger Topologies, Charging Power Levels, and Infrastructure for Plug-In Electric and Hybrid Vehicles, IEEE Transactions on Power Electronics, **28**(5), 2151–2169, May 2012.

¹⁶³ Hartmann, M., Friedli, T., Kolar, J.W. Three-Phase Unity Power Factor Mains Interface of High Power EV Battery Charging Systems, Swiss Federal Institute of Technology (ETH) Zurich, Power Electronic systems Laboratory, https://www.pes.ee.ethz.ch/uploads/tx_eth-publications/ETH_Hartmann_ECPE_3ph_PFC_Rectifier_Topologies_for_EV_Battery_Charging_02.pdf.

¹⁶⁴ Khaligh, A., Dusmez, S. Comprehensive Topological Analysis of Conductive and Inductive Charging Solutions for Plug-In Electric Vehicles, IEEE Transactions on Vehicular Technology, **61**(8), 3475–3489, October 2012.

range of supply voltage (suitable for universal chargers).¹⁶⁵ In a complete two-stage EV charger system, the PFC AC-DC front-end is generally followed by a second-stage DC-DC converter that provides galvanic isolation by a high-frequency transformer and dynamic regulation of output voltage at any desired voltage level for the charging of batteries. This also prevents the usual application of bulky line-frequency transformer (as in the case of non-isolated DC-DC converters) for galvanic isolation of the battery from the electric-grid (required for safety reasons) and allows higher switching frequency operation; the net effect is reduced volume, weight and cost.¹⁶² Moreover, two-stage approach gives the minimum total stress to the circuit components as compared to a single-stage approach, which can be translated into high efficiency, small physical size and low cost.¹⁶⁶ The classical two-stage approach has been recommended as the best option for medium to high power applications, especially for universal line voltage and sinusoidal line current operation. The comparison of single-stage and two-stage approaches of isolated on-board bi-directional chargers for electric vehicles has been reported recently.¹⁶⁷

The two-stage EV charger topology is also selected here as a basis for the modelling; both of the models presented here comprise a conventional AC-DC boost converter as the PFC front-end (from grid-side) operating in CCM with average-current control. The only difference between the two selected topologies is the use of different types of DC-DC converters (isolated-type) in their second-stage. One topology of the selected EV charger uses a half-bridge DC-DC buck converter in the second-stage (from the battery-side) while the other uses a full-bridge DC-DC buck converter. The control methods implemented in the second-stage (isolated-type DC-DC buck converter) of both topologies are also the same. The EV charger topology-1 that uses a half-bridge DC-DC converter has been modelled for output power of 1.68 kW while the EV charger topology-2 employing full-bridge DC-DC converter has been modelled for output power of 4 kW. The selected EV charger topologies have been modelled in PSCAD/EMTDC and their performance has been evaluated at an input voltage of 230 V-rms for different battery charging currents, hence for different output power levels. Further details are given in the following section.

6.5.2 Modelling

Figure 103(a) shows PSCAD-based modelling of EV charger topology-1. It consists of a conventional PFC AC-DC boost converter as the front-end at the grid side (1st stage converter) and a half-bridge DC-DC buck converter at the battery side (2nd

¹⁶⁵ Figueiredo, J.P.M., Tofoli, F.L., Silva, B.L.A. A review of single-phase PFC topologies based on the boost converter, 9th IEEE/IAS International Conference on Industry Applications (INDUSCON), Sao Paulo, pp. 1–6, 2010.

¹⁶⁶ Petersen, L., Andersen, M. Two-stage power factor corrected power supplies: The low component-stress approach, in Proc. 2002 IEEE Appl. Power Electron. Conf. Expo., 2, 1195–1201, 2002.

¹⁶⁷ Koushki, B., Safaee, A., Jain, P., Bakhshai, A. Review and Comparison of Bi-Directional AC-DC Converters with V2G Capability for On-Board EV and HEV, IEEE Transportation Electrification Conference and Expo (ITEC), 2014. 15–18 June, Dearborn, MI, pp. 1–6.

stage converter); these stages are coupled together by a storage capacitor at the DC link. Additionally, two more capacitors (each having a capacity equal to half of a storage capacitor) have been connected in parallel to the energy storage capacitor. These additional capacitors are necessary for the correct operation of the half-bridge DC-DC buck converter. The additional capacitors divide the output voltage of the AC-DC boost converter into two equal halves for input into the half-bridge DC-DC buck converter. The half-bridge DC-DC buck converter uses a centre-tapped high-frequency transformer with a turn ratio of 1:1:1 to provide galvanic isolation. The main advantage of an applied half-bridge DC-DC buck converter is the reduced number of switches and corresponding control circuitry. However, the current stress on the switches is higher, since half of the input voltages appears across the switches (due to duty ratio ≤ 0.5).

Table 24 mentions the parameters of the individual circuit components of the 1st stage (boost converter) and the 2nd stage (buck converter) of the modelled EV charger topologies. The parameters of the PFC AC-DC boost converter (especially the boost inductor and output capacitor) have been selected for the input voltage of 230 V-rms and an output power of 1.8 kW.

The EV charger topology-2 (**Figure 103(b)**) can be applicable for higher output power levels (up to 4 kW) due to the inclusion of a full-bridge DC-DC buck converter. The main advantages of a full-bridge DC-DC buck converter include lower current stress on switches, no additional input capacitors, an output voltage equal to the input voltage (duty ratio ≤ 1) and higher power handling capacity. However, all these advantages are obtained at the cost of two additional switches. The parameters of the 1st stage of EV charger topology-2 have also been selected for an input voltage of 230 V-rms and an output power of 5 kW.

Both of the selected EV charger topologies (**Figure 103(a)** and **(b)**) have been coupled with the electric-grid via a low value (80 μ H) inductor filter. Also, an extra circuitry has been used to control the inrush current. This inrush current control circuitry consists of a series resistor (18 ohm) and a parallel bypass thyristor. A timer block has been used to bypass the series-resistor and turn on the parallel thyristor after the first 18 cycles of supply voltage. At the battery interface, the output inductors and capacitors of both EV charger topologies have been selected in order to have the minimum output voltage and current ripple.

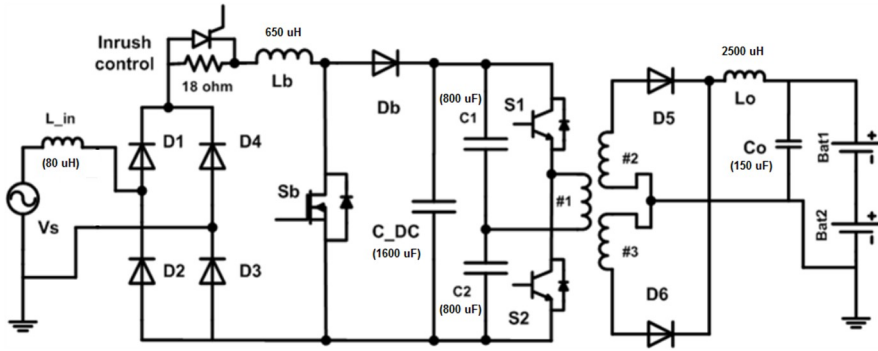

(a)

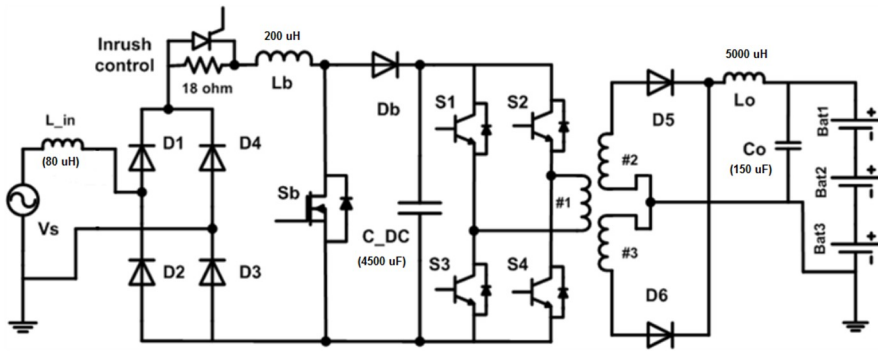

(b)

Figure 103. (a) EV Charger Topology-1 (b) EV Charger Topology-2.

Table 24. Modelling parameters for the selected EV charger topologies.

Parameters	Bridge Diodes	Boost Transistor	Boost Diode	Buck Transistors	Buck Diodes
Turn ON Resistance	0.145 [ohm]	0.045 [ohm]	0.167 [ohm]	0.19 [ohm]	0.077 [ohm]
Turn OFF Resistance	0.1x10 ⁶ [ohm]	1.0x10 ⁶ [ohm]	0.5x10 ⁶ [ohm]	1.0x10 ⁶ [ohm]	0.5x10 ⁶ [ohm]
Forward Voltage Drop	1.0 [volt]	4.0 [volt]	1.2 [volt]	4.0 [volt]	1.0 [volt]
Forward Breakover Voltage	1000 [volt]	1000 [volt]	1000 [volt]	1000 [volt]	1000 [volt]
Reverse Withstand Voltage	1000 [volt]	1000 [volt]	1000 [volt]	1000 [volt]	1000 [volt]
High Frequency Transformer Parameters:					
kVA rating	2-4 kVA	Leakage Reactance	0.01 [pu]	No load losses	0.025 [pu]
Frequency	40/70/120 kHz	Rated Voltage	300–400 [volts]	Copper losses	0.015 [pu]
Turn Ratio	1:1:1	Saturation	Disabled	Efficiency	96%

6.5.3 Simulation results

The performance of the modelled chargers was studied in simulations. The main focus was on the effects on the grid, primarily the harmonic distortion, and the overall efficiency of the charger. Also, the effects of various design parameters and operational states were studied. In the following, **Table 25** summarises the results and **Figure 104** shows an example of the simulation results illustrating the voltage and current waveforms. **Figure 105** shows the comparison of individual harmonic distortion with IEEE 519 limits at full load and 25% partial load for EV charger topology-1.

Table 25. Simulation results for the EV charger topology-1.

No.	I _{charging} [A]	THD-I _{grid} [%]	Ripple-I _{out} [%]	Grid P.F	P _{grid} [kW]	P _{out} [kW]	Efficiency AC-DC [%]	Efficiency DC-DC [%]	Efficiency Overall [%]
Input voltage: 230 V, Switching Frequency: 40 kHz (for both stages)									
1.	6.67	2.22	2.22	0.991	1.902	1.683	95.5	92.7	88.5
2.	3.35	4.1	4.36	0.987	0.965	0.835	96.9	89.3	86.6
3.	1.675	6.7	7.4	0.981	0.510	0.415	95	85.7	81.4
Input voltage: 230 V, Switching Frequency: 70 kHz (for both stages)									
1.	6.67	2.24	2.22	0.981	1.91	1.682	94	93.2	88.3
2.	3.35	4.04	3.8	0.979	0.966	0.835	95.5	90.6	86.5
3.	1.675	6.74	6.9	0.974	0.512	0.415	94	86.1	81.3
Input voltage: 230 V, Switching Frequency: 120 kHz (for both stages)									
1.	6.67	2.26	1.64	0.988	1.91	1.6825	95.9	91.9	88.1
2.	3.35	4.02	2.95	0.987	0.967	0.835	96.8	89	86.2
3.	1.675	6.58	5.37	0.988	0.515	0.416	96	84.7	81.4

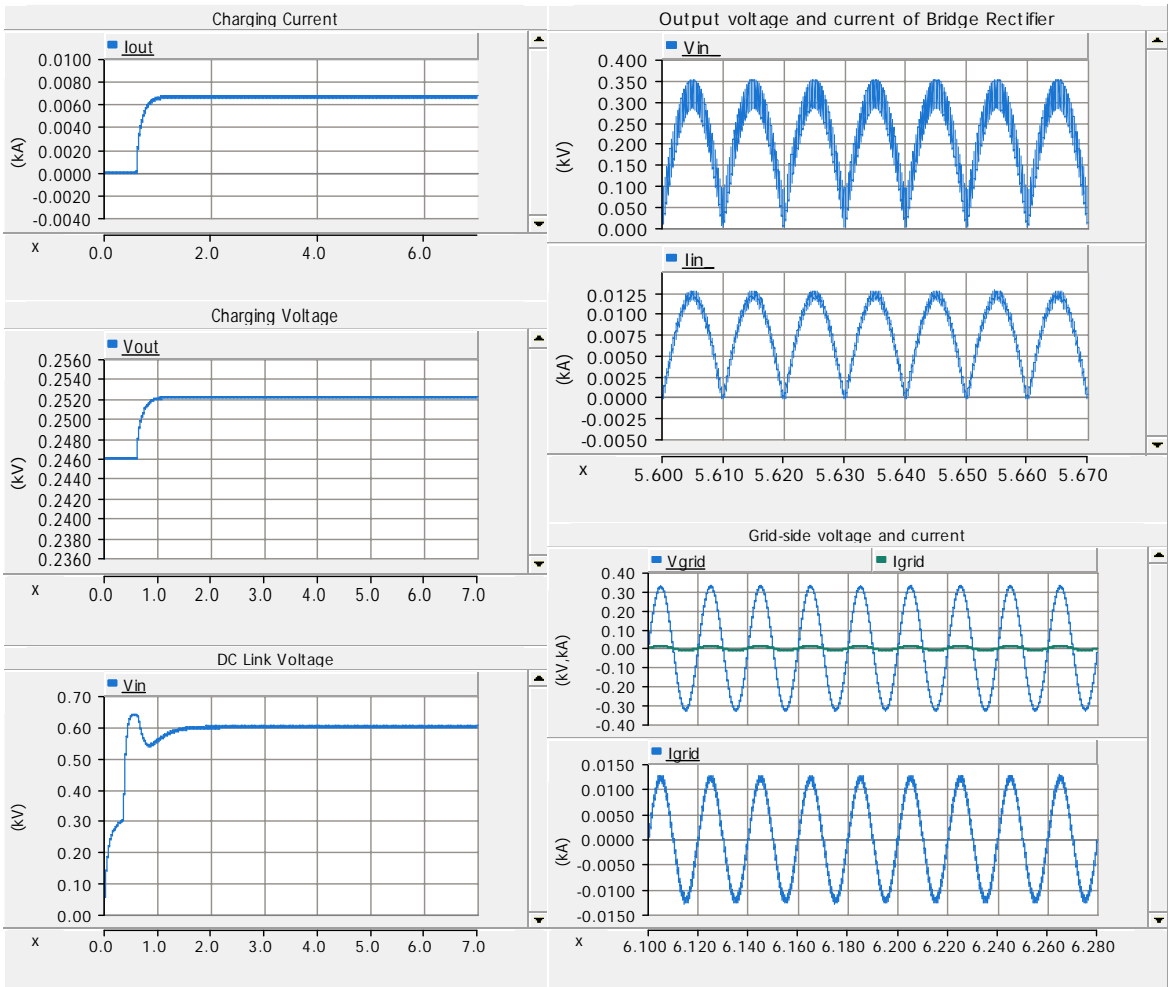

Figure 104. Input and output voltage and current waveforms for EV charger topology-1 (1.68 kW).

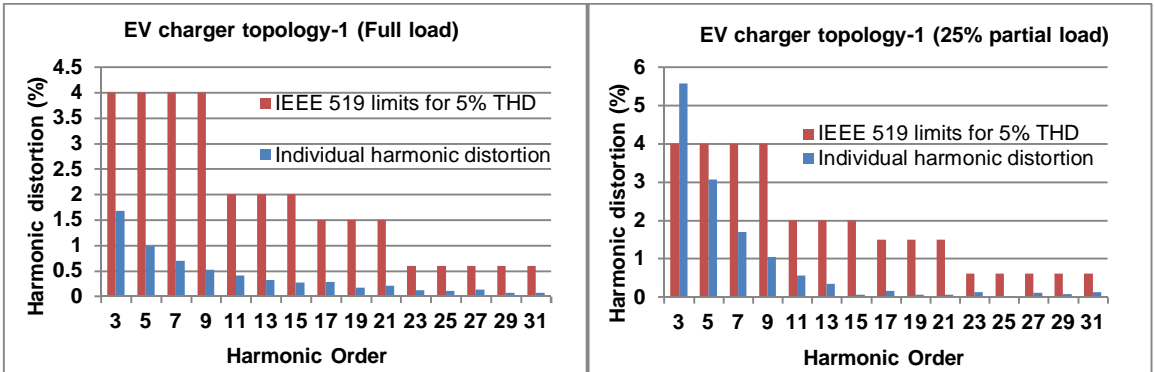

Figure 105. Comparison of individual harmonic distortions at 40 kHz switching frequency with IEEE 519 limits.

6.5.4 Discussion

There exists a large number of various charger topologies for electric vehicles, which has been briefly reviewed here, while a more extensive review will be published later in a separate publication. The main target of the research has been to develop charger models suitable for grid integration studies. On the other hand, the target has been to develop models that included all the elements up to the battery, so that every possible interaction can be analysed. In this respect, one of the next steps will be the analysis of possible electrical safety hazards due to faults in various parts of the charging system while it is connected to the grid.

The performance of the developed models has been tested in simulations and the results indicate that in normal operation the models have low enough harmonic levels and a realistic level of efficiency. In regard to the efficiency, the models also show lower efficiencies with partial load.

6.5.5 Conclusions

In this work, the topologies of EV chargers has been studied. As a practical result, a set of models has been developed to represent typical charger configurations. In the development work, the focus has been on the grid effects and thus the models may actually represent the high-end grid-friendly alternatives. The models developed are also a useful tool for the detailed analysis of EV grid integration, while considering especially various transient events.

6.5.6 Acknowledgements

The authors want to acknowledge the financial support from Tekes to the ECV-eCharge project, which enabled this work as well as all the partners within the ECV network for their cooperation.

7. Electric and hybrid working machinery

7.1 Future trends of hybrid and electric powertrains in non-road mobile machinery

Authors: Antti Lajunen¹, Panu Sainio¹, Lasse Laurila², Jenni Pippuri³, Kari Tammi^{1,3}
Affiliations: ¹Aalto University, ²Lappeenranta University of Technology, ³VTT Technical Research Centre of Finland Ltd
Current contact information for main author: antti.lajunen@helsinki.fi

Abstract

This paper examines the future trends of hybrid and electric powertrains in non-road mobile machinery (NRMM) with the focus on the challenges and opportunities related to the electrification of NRMM. The underlying trends and drivers, such as regulations, policies and market development, are analysed in order to draw conclusions about possible future scenarios. Required technology enablers and foreseen challenges are identified based on a state-of-the-art review of electrical components and systems. Future scenarios are developed based on the technological development of key components, scientific literature and the status of the non-road mobile machinery industry. These scenarios are divided into two time horizons: short to medium term and long-term periods. The key results are summarised in the form of actions required for the successful electrification of non-road mobile machinery. Some recommendations are also given in relation to the development of the technology and NRMM markets.

7.1.1 Introduction

Electrification of vehicles and non-road mobile machinery (NRMM) is considered to be an effective way to increase energy efficiency and reduce emissions. Despite the benefits of electric powertrains and components, electrification has been slower than expected due to various technological factors, market drivers and policies. Understanding the complex technological transitions and changes at the industrial level requires thorough analysis and systematic evaluation of the underlying phenomena related to the technology itself, future developments, market situation and prevailing policies and regulations. Global understanding of the need to reduce pollutant and greenhouse gas emissions is supporting the development and adoption of alternative and advanced technologies. The majority of the mobile machines are operated by professionals for whom lifecycle costs and payback time are important factors in assessing the economic feasibility of different technologies. Energy efficiency is becoming more and more central, especially in view of energy and fuel price volatility. Although fossil fuels are cost-competitive at present, the price of crude oil may rise or fall rapidly due to the sensitivity of the oil market. Signs of

decreasing dependency on fossil fuels are already evident in the automotive industry.

This paper presents a thorough evaluation of future technological developments in NRMM focusing on hybrid and electric powertrains and their main components. This work was carried out during 2012–2015 under the ECV-Tubridi project in collaboration with Aalto University, Lappeenranta University of Technology, VTT Technical Research Centre of Finland Ltd and industry partners. The original work was done in the form of Technology Roadmap, which provides the basis for this paper. Firstly, predictions for the electrification and hybridisation of non-road mobile machinery are presented. The following sections elucidate and provide support for these predictions. A brief state-of-the-art overview of the electrification of NRMM is then given and the present and future drivers of electrification and technological trends are presented. Following this, the required technology enablers and major challenges are discussed, and finally, recommendations and required actions are summarised.

7.1.2 Predictions for the electrification of mobile machinery

The ongoing progress of improving energy efficiency and reducing emissions will be the dominant driver of the electrification of mobile machinery. Fuel consumption will be a major focus since improved fuel economy is key to reducing machine emissions and operating costs. Stringent future regulations on the air pollutant emissions of diesel engines in NRMM will influence the system design of the ICE, but the impact will be different for each machine type. The following sections present the predictions for the short and medium term and for the long term.

7.1.2.1 Short- and medium-term predictions

In this context, short-term period is defined as less than five years, and the medium-term up to ten years. The service life of mobile machinery can be much longer than that of on-road vehicles, even up to 20 years. Medium- and long-term visions are considered to have more importance than short-term considerations. That said, changes in the market economy can happen fast, forcing companies to make strategic short-term decisions. The following list describes the main impacting factors and development themes for the short and medium term:

- Air pollutant emission regulations enforcement on all power classes (Tier IV and EU Stage V)¹⁶⁸. This will increase the need for emission control and exhaust gas treatment systems. Interest towards hybrid powertrain solutions is expected to increase significantly, if emission control is easier, and in some cases less expensive, through hybridisation.

¹⁶⁸ Procedure 2014/0268/COD, COM(2014) 581 final, "Proposal for a regulation of the European parliament and of the council on requirements relating to emission limits and type-approval for internal combustion engines for non-road mobile machinery," 2014.

- Consumption of fossil fuels will increase and no decrease or shortages in crude oil production are foreseen. However, attitudes towards fossil fuels are becoming less favourable. The price of oil will remain a subject of speculation due to global political unrest and instability in some important oil producing regions¹⁶⁹. Fuel price should therefore not be the primary driving force for electrification.
- Development of electric components for vehicular applications will be continuous, volumes will increase and they will become more available also for higher voltage and power levels. Electrification of on-road vehicles will be an important factor for electric component development and for technology cost reductions.^{170,171,172}
- Development of electric powertrains in certain already largely electrified machinery sectors (locomotives, forklifts etc.) will continue incrementally. However, this will not necessarily have a major impact on the general development of electric powertrains.^{173,174} The benefit of electrification or hybridisation will need to be justified separately for each NRMM type.
- Use of renewable energy sources (e.g. wind and solar) will transform traditional energy production and distribution (local vs. global energy production). There will be a growing need for local stationary electrical energy storages.¹⁷⁵
- Gradual steps towards higher degree of electrification of NRMM will be taken, e.g.: auxiliary devices → power assist → full hybrid → full electric. First, hybrid machines will be equipped with small batteries, and then, mostly due to technology cost reductions, with higher capacity batteries in full hybrid and electric powertrains. There will not be generic powertrain layouts for NRMM but more likely integrated systems that can be shared between different types of mobile machines.

¹⁶⁹ Beidas-Strom, S., Pescatori, A. Oil Price Volatility and the Role of Speculation, IMF Working Paper, WP/14/218, December 2014.

¹⁷⁰ van Vliet, O.P.R., Kruithof, T., Turkenburg, W.C., Faaij, A.P.C. Techno-economic comparison of series hybrid, plug-in hybrid, fuel cell and regular cars, *Journal of Power Sources*, **195**(19), 6570–6585, October 2010.

¹⁷¹ Weiss, M., Patel, M.K., Junginger, M., Perujo, A., Bonnel, P., van Grootveld, G. On the electrification of road transport – Learning rates and price forecasts for hybrid-electric and battery-electric vehicles, *Energy Policy*, **48**, 374–393, September 2012.

¹⁷² Sakti, A., Michalek, J.J., Fuchs, E.R.H., Whitacre, J.F. A techno-economic analysis and optimization of Li-ion batteries for light-duty passenger vehicle electrification, *Journal of Power Sources*, **273**, 966–980, January 2015.

¹⁷³ Gaines, L.L., Elgowainy, A., Wang, M.Q. Full Fuel Cycle Comparison of Forklift Propulsion Systems, Center for Transportation Research, Argonne National Laboratory, October 2008.

¹⁷⁴ Jaafar, A., Sareni, B., Roboam, X. A Systemic Approach Integrating Driving Cycles for the Design of Hybrid Locomotives, *IEEE Transactions on Vehicular Technology*, **62**(8), 3541–3550, October 2013, doi:10.1109/TVT.2013.2267099.

¹⁷⁵ Lund, P.D., Lindgren, J., Mikkola, J., Salpakari, J. Review of energy system flexibility measures to enable high levels of variable renewable electricity, *Renewable and Sustainable Energy Reviews*, **45**, 785–807, May 2015.

- Mobile machine-specific, tailored system solutions will enter the market. For instance, similarly to heavy-duty on-road vehicles (city buses), integrated transmission systems with diesel engine and electric motor(s) will be developed and commercialised.¹⁷⁶

7.1.2.2 Long-term predictions

Long term is defined as 10 to 30 years. Over this time horizon, the major trend will be the implementation of automation in different forms in machines. Mobile machinery will typically be used in somewhat limited applications involving continuously repeating similar work tasks. The operation of many machines will become automated as has already been partly achieved e.g. with underground mining loaders.¹⁷⁷ As already observed in the automotive sector, advanced driver assistance systems (ADAS) will continue to be integrated in vehicles year on year.^{178,179} In the early stages of automation, work machines will require operator supervision due to complicated environments and tasks that are difficult to fully automate. The following list describes the predictions for the long term:

- Automation will be a major driving force supporting the utilisation of electric powertrains as electric components and systems are more accurate to control and measure than hydraulic or mechanical systems.
- Autonomous machines (without a human operator) will promote a diversity of sizes and/or power classes of machines. Driver/operator costs will become smaller, machines can work 24/7 and can be smaller.
- Demand for energy efficiency and automation are favouring the implementation of fully electric drivetrain solutions. We estimate that by 2035 half of all new machines will be equipped with some degree of electric powertrain.
- Changes in energy production and distribution (e.g. local vs. global energy production, politics, global crises) will favour locally produced, independent energy sources. Much more renewable energy will be available for distribution via the electrical grid.
- Overall consumption of fossil fuels will continue to increase, but oil production may decrease and use of fossil fuels in vehicles will diminish. Oil prices are likely to increase but will always be a subject of speculation.¹⁶⁹

¹⁷⁶ HybriDrive Propulsion Systems, Bae Systems, <http://www.hybridrive.com/> (accessed 15-Jan-2016).

¹⁷⁷ Gustafson, A. Automation of Load Haul Dump Machines, Research Report, Luleå University of Technology, 2011.

¹⁷⁸ Li, L., Wen, D., Zheng, N-N., Shen, L-C. Cognitive Cars: A New Frontier for ADAS Research, *IEEE Transactions on Intelligent Transportation Systems*, **13**(1), 395–407, March 2012, doi:10.1109/TITS.2011.2159493.

¹⁷⁹ Golestan, K., Soua, R. Karray, F., Kamel, M.S. Situation awareness within the context of connected cars: A comprehensive review and recent trends, *Information Fusion*, **29**, 68–83, May 2016.

- Drop-in biofuels will play a growing role in the fuel market, influencing the price and demand for fossil fuel components.¹⁸⁰
- Fuel cell technology will start to be cost competitive and increasing hydrogen production will lower fuel prices.^{181,182}

7.1.3 State-of-the-art

Electric power has been used in non-road mobile machinery for a long time. In some machine applications, usually heavy-duty machines, an electric powertrain is the only suitable option due to the high torque demand at the wheels and required level of controllability. However, electric powertrains have not been adopted at a large scale in mobile machinery. Recent technological developments indicate that many typical machines can benefit from the use of electric powertrains.^{183,184} Historically, the internal combustion engine (ICE), primarily the diesel engine, has dominated power production in machines. Diesel engines have good efficiency among the ICE family, and emission regulations have not brought technical challenges or significantly increased the cost of the technology. However, this is changing along with stricter emission regulations that will include all power levels of engines and new regulations with limitations on the mass and number of particles.¹⁸⁵

Hydraulic systems are widely used in NRMM. Mobile machinery often operates at low speeds with a high torque capacity demanded at the wheels.¹⁸⁶ Hydrostatic or hydrodynamic powertrains are therefore well suited to many such machines. Hydraulic systems also offer a good power-to-weight ratio, an important advantage in limited spaces. Most work systems, such as boom or bucket operations, are powered by hydraulic cylinders that are difficult to replace with a corresponding electric

¹⁸⁰ Karatzos, S., McMillan, J.D., Saddler, J.N. The Potential and Challenges of Drop-in Biofuels, A Report by IEA Bioenergy Task 39, Report T39-T1 July 2014.

¹⁸¹ Mayer, T., Kreyenberg, D., Wind, J., Braun, F. Feasibility study of 2020 target costs for PEM fuel cells and lithium-ion batteries: A two-factor experience curve approach, *International Journal of Hydrogen Energy*, **37**(19), 14463–14474, October 2012.

¹⁸² James, B.D., Moton, J.M., Colella, W.G. Mass Production Cost Estimation for Direct H₂ PEM Fuel Cell Systems for Transportation Applications – 2013 Update, Strategic Analysis Inc., January 2014.

¹⁸³ Jo, D-Y., Kwak, S. Development of fuel-efficient construction equipment, IEEE 8th International Conference on Power Electronics and ECCE Asia (ICPE & ECCE), South Korea, May 30 – June 3, 2011.

¹⁸⁴ Mol, C., O'Keefe, M., Brouwer, A., Suomela, J. Trends and insight in heavy-duty vehicle electrification, The 25th World Battery, Hybrid and Fuel Cell Electric Vehicle Symposium & Exhibition, EVS-25, Shenzhen, China, November 5–9, 2010.

¹⁸⁵ Procedure 2014/0268/COD, COM(2014) 581 final, Proposal for a regulation of the European parliament and of the council on requirements relating to emission limits and type-approval for internal combustion engines for non-road mobile machinery, 2014.

¹⁸⁶ Lajunen, A. Energy Efficiency of Conventional, Hybrid Electric, and Fuel Cell Hybrid Powertrains in Heavy Machinery, SAE technical paper 2015-01-2829, 2015, doi:10.4271/2015-01-2829.

system. The downside of hydraulic systems is their lower energy efficiency compared to mechanical or electric systems.¹⁸⁷ Hydraulic pumps and motors incur considerable idling losses in a typical operation of a mobile machine because flow and pressure in the system have to be maintained even when the machine is not moving. Electrification and hybridisation are considered relevant options to replace hydrostatic and hydrodynamic powertrains in order to increase energy efficiency and also to improve controllability.¹⁸⁸

Hybridisation of on-road vehicles has been successful and various new models are entering the market each year. For the time being, hybridisation has been very limited among NRMM, although there are some specific applications in which it has been successful also from the cost perspective.¹⁸³ The major challenges relate to the cost of the electric components and the higher reliability and durability requirements of mobile machinery. The development of lithium-based batteries has had a significant impact on the feasibility of electric powertrains.¹⁸⁹ These types of batteries offer adequate energy and power capacity for most machines. In many machine applications, energy buffering is often needed only for short time periods at high power levels, with ultracapacitors used for energy storage instead of batteries.¹⁹⁰ Ultracapacitors can offer very high power-to-weight ratios, but energy capacities are much lower in comparison to batteries.¹⁹¹ Hybridisation can here be considered a tool for risk management of battery technology. The requirements of machine operation are not easily met with only electrical energy storage as an energy source. Instead, a hybrid powertrain, typically a diesel engine generator together with a lithium-ion battery, can be a much more reasonable solution than a fully electric powertrain for many non-road mobile machines. For emission-free operation, fuel cells can be used as the primary power source of the hybrid powertrain.¹⁹² High production costs and durability are the major challenges for vehicular fuel cell systems.¹⁹²

¹⁸⁷ Lajunen, A., Leivo, A., Lehmuspelto, T. Energy consumption simulations of a conventional and hybrid mining loader, The 25th World Battery, Hybrid and Fuel Cell Electric Vehicle Symposium & Exhibition, EVS-25, Shenzhen, China, November 5–9, 2010.

¹⁸⁸ Lajunen, A., Suomela, J. Evaluation of Energy Storage System Requirements for Hybrid Mining Loader, *IEEE Transactions on Vehicular Technology*, **61**(8), 3387–3393, October 2012.

¹⁸⁹ Khaligh, A., Li, Z. Battery, Ultracapacitor, Fuel Cell, and Hybrid Energy Storage Systems for Electric, Hybrid Electric, Fuel Cell, and Plug-In Hybrid Electric Vehicles: State of the Art, *IEEE Transactions on Vehicular Technology*, **59**(6), 2806–2814, July 2010.

¹⁹⁰ Parkhideh, B., Mirzaee, H., Bhattacharya, S. Supplementary Energy Storage and Hybrid Front-End Converters for High-Power Mobile Mining Equipment, *IEEE Transactions on Industry Applications*, **49**(4), 1863–1872, July/August 2013.

¹⁹¹ Rotenberg, D., Vahidi, A., Kolmanovsky, I. Ultracapacitor Assisted Powertrains: Modeling, Control, Sizing, and the Impact on Fuel Economy, *IEEE Transactions on Control Systems Technology*, **19**(3), 576–589, May 2011.

¹⁹² Liukkonen, M., Lajunen, A., Suomela, J. Feasibility study of fuel cell-hybrid powertrains in non-road mobile machineries, *Automation in Construction*, **35**, 296–305, July 2013.

7.1.4 Technology drivers and trends

7.1.4.1 Legislation and policies

In a broader context, the strategies of the European Union (EU) and individual countries towards reduction of carbon dioxide (CO₂) emissions may have an important impact on the design solutions of NRMM. The ambitious EU objective is to reduce greenhouse gas emissions in Europe by 80–95% by the year 2050 compared to 1990 levels. At present, it is difficult to estimate future actions and requirements that could be directed at vehicles and mobile machines, but solutions that reduce dependence on fossil fuels will certainly be required. It also has to be recognised that the target level cannot be reached simply by increasing the energy efficiency of conventional technologies. The CO₂ emission reduction objectives are also complemented with other policies and declarations designed to map the path to competitive and resource efficient transportation in Europe.¹⁹³

Emission standards are other legislative policies that have an impact on the technology choices for mobile machines. Emission limits for pollutants will lower in future legislation, and new limitations will also be imposed. According to the preparation of the EU Stage V emission standards¹⁸⁵, also small (<19 kW) and large size engines (>560 kW) will be included in the legislation. **Table 26** describes the present European emission limits (Stage III/IV) and future limits (Stage V).

Table 26. European emission limits for CI engines of NRMM (g/kWh).

Power range [kW]	Stage III/IV				Stage V			
	CO	HC	NOx	PM mass	CO	HC	NOx	PM mass
0 < P < 8	No limits				8.0	(HC+NOx ≤ 7.5)		0.4
8 ≤ P < 19	No limits				6.6	(HC+NOx ≤ 7.5)		0.4
19 ≤ P < 37	5.5	(HC+NOx ≤ 7.5)		0.6	5.0	(HC+NOx ≤ 4.7)		0.015
37 ≤ P < 56	5.0	(HC+NOx ≤ 7.5)		0.025	5.0	(HC+NOx ≤ 4.7)		0.015
56 ≤ P < 130	5.0	0.19	0.4	0.025	5.0	0.19	0.4	0.015
130 ≤ P < 560	3.5	0.19	0.4	0.025	3.5	0.19	0.4	0.015
P > 560	No limits				3.5	0.19	3.5	0.045

As a new rule, particle mass and particle number emissions are included. The direct impact of the new emission limits is the need for more sophisticated emission control and exhaust gas treatment systems. In the past, the emission standards have been

¹⁹³ COM(2011) 0144 final, "WHITE PAPER Roadmap to a Single European Transport Area – Towards a competitive and resource efficient transport system," European Commission, Brussels, 2011.

stricter for heavy-duty on-road vehicles than for non-road mobile machinery. Nowadays, new heavy-duty trucks often have to use exhaust gas recirculation (EGR), selective catalyst reduction (SCR) and diesel particle filters (DPF) to reach present emission limits such as EURO VI in Europe.¹⁹⁴

7.1.4.2 Competition

Although electric and hybrid powertrains hold great promise and inherent advantages over conventional powertrains, they are and will be in competition with other technologies. It is never easy to be the contender, and it has to be remembered that conventional technologies will also be further developed, e.g. to be more energy efficient. In passenger vehicles, the internal combustion engines have been able to meet the challenge set by hybrid vehicles. Today's downsized diesel and petrol engines have achieved low consumption levels and together with turbocharging offer a very powerful alternative even for larger cars. Diesel technology has also been developed among NRMM, but future emission standards could require redesigns and further development of emission control and exhaust gas treatment, in turn increasing engine system size and costs. However, from the technology development point of view, fair competition between different technologies can also be a positive trend for hybrid and electric powertrains.

Hydraulic systems are widely used in mobile machinery and a lot of effort will therefore be put into developing more energy efficient and powerful hydraulic systems. Digital hydraulics is entering the mass market and boosting energy efficiency and control accuracy. The impact of new fuel types and sources that are more environmentally friendly than conventional fossil fuels, e.g. biofuels, should also be considered.

7.1.4.3 Exploiting the opportunities

An electric powertrain can be seen as an innovation platform to enhance the performance of conventional technology and offer new, advanced solutions to customers. Driving comfort – a key requirement for passenger vehicles – has also been acknowledged as an important feature for mobile machines. Machine control using electric systems can enhance the user experience and make previously stressful work much more comfortable, which could be an important selling point in the future. For instance, agricultural tractors equipped with an electric power take-off (PTO) may encourage other manufacturers to design equipment that runs on electric

¹⁹⁴ Regulation (EC) No 595/2009 of the European Parliament and of the Council, on type-approval of motor vehicles and engines with respect to emissions from heavy duty vehicles (Euro VI) and on access to vehicle repair and maintenance information and amending Regulation (EC) No 715/2007 and Directive 2007/46/EC and repealing Directives 80/1269/EEC, 2005/55/EC and 2005/78/EC.

power instead of mechanical or hydraulic power.^{195,196} **Figure 106** presents an example DC Powerbus architecture of an electric PTO system for agricultural tractors.

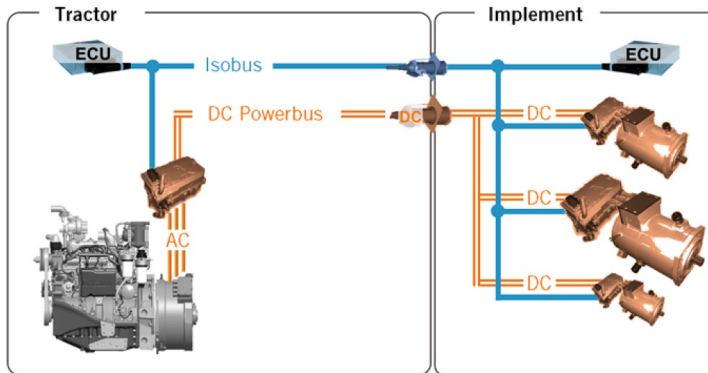

Figure 106. DC Powerbus architecture for tractor.¹⁹⁶

The most likely scenario for electrification is a gradual transition from a mild hybrid to a plug-in hybrid or fully electric NRMM. While the first steps towards electrification have long since been taken, external factors continue to have a strong impact on the speed of progress. Nowadays, all machines have at least one electrical system, typically a 24 V lead-acid battery based system delivering power to the auxiliary devices such as ventilation, lights, and windscreen wipers. However, only components with a continuous power of less than 1 kW can be operated with such a low voltage system and the number of auxiliary devices is generally increasing.

The same challenge has been recognised in the passenger vehicles, where the number of comfort and infotainment auxiliary devices has been increasing rapidly. One possible step is to implement another electric system with a higher voltage level than 24 V but still lower than 96 V, which is often considered the limit for high voltage in vehicles and mobile machinery. This is because higher voltage systems have specific requirements that could unnecessarily increase the system costs. A 96 V system offers more than 10 kW of power which, in turn, enables the use of more powerful electric auxiliary devices, such as engine fans or electric motor powered hydraulic systems. A higher capacity battery could also provide auxiliary power during stop and start operation of the engine.

¹⁹⁵ Buning, E.A. Electric drives in agricultural machinery – approach from the tractor side, Club of Bologna 21st Annual Meeting Key Note Report, Bologna, EIMA International, November 13–14, 2010.

¹⁹⁶ Electrification of tractors. ATZ, April 2014.

7.1.5 Technology enablers

7.1.5.1 Technology hypes

Many new technologies go through a 'hype' phase of inflated expectations of what they can actually provide. The hype around vehicle electrification, especially electric passenger cars, reached something of a peak around 2010. During the hype phase, a lot of promises are typically made while the actual development and maturity of the technology are overlooked. Technology hypes do, however, have some positive outcomes.

They boost interest in the technology. They encourage governments and other decision makers to lower legislative barriers, e.g. on emissions and taxation. Sometimes, a technological hype is what it takes to draw enough attention to get crucial funding for development. Early investors may also benefit from the hype through higher returns. A negative, often inevitable outcome of hype is that it is followed by disillusionment in the technology or disappointment that progress is slower than expected or promised, coming in gradual incremental steps rather than as bolt-out-of-the-blue disruptor. Real growth and dedicated work usually gets going after the hype peak has been reached and expectations become more realistic.¹⁹⁷ **Figure 107** shows a comparison of technology expectations between a hype curve and more linear managed expectations.

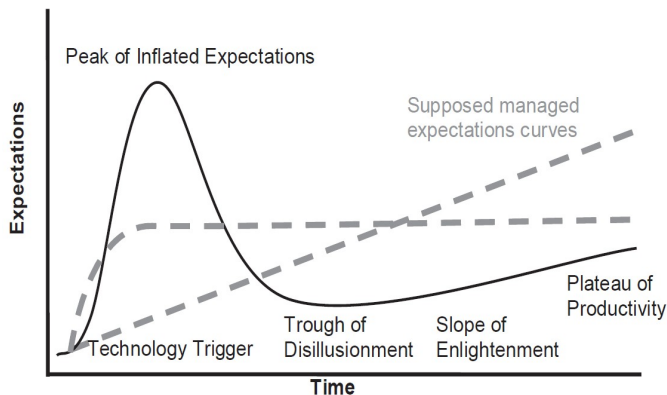

Figure 107. Technology expectations: hype curve vs. managed expectations.¹⁹⁷

7.1.5.2 System integration

As hybridisation will probably be the first major step for mass electrification of mobile machinery, there is and will be a crucial need for certain integrated subsystems such as diesel-generators and motor-transmissions. Current diesel generators are mostly

¹⁹⁷ Bakker, S., Budde, B. Technological Hype and Disappointment – Lessons from the Hydrogen and Fuel Cell Case, EVS26 Los Angeles, California, May 6–9, 2012.

manufactured for stationary use and do not correspond to the needs of mobile machines. A diesel generator for a mobile machine needs to be compact in size and as controllable as any current diesel engine. Another integrated system is the combination of the electric motor and gearbox. As many machines operate only at low driving speeds and require a substantial amount of torque at the wheels, gear reductions have to be used from the electric motor to the wheels. Conventional gearboxes used with diesel engines can be used, but these are far from optimal and specific gearboxes are therefore often used with electric motors. The gearbox design is also different because shifting can be performed without a clutch due to the high accuracy of the motor control.

7.1.5.3 Component development

Electrical energy storage is a key component contributing to the successful electrification of mobile machinery. The development of lithium-ion batteries has been highly beneficial, but progress has not been as fast as many forecasts had given reason to believe.¹⁹⁸ Battery capacity (power and energy) and lifetime are crucial development areas to be followed. In the wake of lithium-based batteries, other more advanced battery chemistries are being developed.^{199,200} Some of these hold a lot of promise, such as lithium–sulphur and metal–air batteries, but their development from concept to the actual real size battery system takes a lot of time, even more than ten years.

Even though batteries are often in the spotlight, ultracapacitors (often also called supercapacitors) have been developed to the level that their usability, feasibility and applicability are approaching that of batteries.²⁰¹ However, as long as ultracapacitors remain as low energy capacity storage, they will be most suitable for short-term energy buffering in high power applications. Combining ultracapacitors with energy type batteries could sometimes be useful, but the cost efficiency could be hard to reach and the system could become complicated e.g. from the control point of view.

Besides the key components of the electric powertrain (battery, inverter/converter, motor), there are a lot of other smaller size components, such as electric connectors, cables, contactors and fuses that can increase costs and engineering work. The system integration in electric and hybrid systems plays a very important role in attaining reasonable costs, easy assembly, effortless maintenance and long-

¹⁹⁸ Budde-Meiwes, H., Drillkens, J., Lunz, B., Muennix, J., Rothgang, S., Kowal, J., Sauer, D.U. A review of current automotive battery technology and future prospects, Proceedings of the Institution of Mechanical Engineers, Part D: Journal of Automobile Engineering, **227**(5), 761–776, April 2013.

¹⁹⁹ Lu, L., Han, X., Li, J., Hua, J., Ouyang, M. A review on the key issues for lithium-ion battery management in electric vehicles, Journal of Power Sources, **226**, 272–288, March 2013.

²⁰⁰ Campillo, J., Ghaviha, N., Zimmerman, N., Dahlquist, E. Flow batteries use potential in heavy vehicles, International Conference on Electrical Systems for Aircraft, Railway, Ship Propulsion and Road Vehicles (ESARS), Aachen, Germany, March 3–5, 2015, pp. 1–6, doi:10.1109/ESARS.2015.7101496.

²⁰¹ Burke, A., Miller, M. The power capability of ultracapacitors and lithium batteries for electric and hybrid vehicle applications, Journal of Power Sources, **196**(1), 514–522, January 2011.

term reliability and durability²⁰². In this context, the challenge is the availability of reasonably priced components that satisfy the defined specifications. Particularly, components suitable for high voltage systems (> 650 V) are usually not off-the-shelf products but specific designs for a particular application without mass production.

Although electric motors have long been used in vehicles and other applications, there is a need for further development of electric motors specifically for mobile machinery and heavy-duty vehicles. The majority of electric motors used worldwide are designed for stationary use in industrial conditions and hence their specifications do not match those of mobile machines. Again, compact size, i.e. good power-to-weight or torque-to-weight ratio and high energy efficiency over a broad operation range are important characteristics that are not necessarily so relevant for stationary machines. In mobile drives, weight must be minimised due to limited energy storage capacity. This applies also to the mass of the electric motor drive. Therefore, sophisticated motor design, control and efficient cooling are needed. Mobile machines also require good torque capacity, which can increase the size and cost of the motor. For this reason, use of an electric motor with integrated gearbox for higher torque capacity can be advantageous.

7.1.5.4 Cost reduction

The high cost of electric components is often the prime challenge for economically successful electrification or hybridisation of non-road mobile machinery. As a case in point, the first full hybrid passenger vehicle (Toyota Prius) entered the market in 1997 yet it took more than ten years to make the car profitable. Cost reduction of individual components is important but because NRMM are so diverse, system development and integration costs can be considered even more important. For example, the future cost estimates for lithium-ion batteries at the cell level do not accurately represent a battery system cost in which system integration, battery management and cooling systems play a major role. It is noteworthy that Toyota adopted the Prius drivetrain technology not only in a lower segment passenger car product line model but licenced it to other brands and sectors. Originally named the Toyota Hybrid system (THS), today Hybrid Synergy Drive (HSD) is the Toyota brand name for hybrid car drivetrain technology.

Integrated powertrain systems, such as engine generators and traction motor gear systems, can be a solution for cost reduction at the system level. As the design and development of a hybrid or electric powertrain is an expensive process, one-off solutions should be avoided in favour of integrated modular design. Overall, cost management should be extended to the vehicle and business levels, since the economic benefits of electric and hybrid powertrains are more likely to derive from the lifecycle context than only from individual factors, such as fuel cost.

²⁰² Moreno, G., Narumanchi, S., Bennion, K., Waye, S., DeVoto, D. Gaining Traction: Thermal Management and Reliability of Automotive Electric Traction-Drive Systems, *IEEE Electrification Magazine*, 2(2), 42–49, June 2014.

7.1.6 Considerations and recommendations

New technology brings risks as well as rewards. In the market economy, strategic decisions on the choice of technology are never easy and the possible risks of adopting new technologies have to be somehow managed. In the field of mobile machinery, conventional technologies (diesel engines and hydraulic systems) will be present for a long time because they are robust, reliable and well-known with an established range of known suppliers. Due to external factors and competition, however, implementation of the new technology is inevitable and manufacturers and operators will have to adapt to the new market environment. In this context, patience can be advantageous, especially in system innovations requiring multiple actors to cooperate and develop technologies in tandem. It is not necessary to be the first to offer a new technology, but failure to be prepared for its adoption can be risky in the long run. One approach is to seek out new partners, such as electric utility companies, service companies, and leasing and finance actors, and through these gain an understanding of the changes brought and offered by electrification. It should be remembered that lifecycle management of hybrid and electric powertrains will be an important factor in the economic success of NRMM electrification. Successful demonstration machines will serve as references and boost confidence in electric NRMM.

Machinery applications with electric powertrains have already achieved economic market success. Large-scale adoption of electric and hybrid machinery however needs more push from manufacturers and active participation from end users. For faster introduction and adoption of electric powertrains, it is crucial to have:

- Strong understanding of the cost effectiveness and management of electric powertrains
- Effective collaboration between industry, R&D, legislative bodies and end users
- Strategic benefit from technology hypes, e.g. in consumer market products and public funding, and
- Clear understanding of own and good enough understanding of partners' and customers' business models.

Reliance on a single technology or supplier carries an inherent business risk. Due to economy-driven global politics, energy and material prices are vulnerable and subject to substantial fluctuation, such as significant change in crude oil prices even over the short term (2014–2015). Rapid growth of the conventional electric motor and power electronics markets could bring about price instability in the markets for limited raw materials.

Based on the present technology and market situation, it seems that the success of hybrid powertrains will not be determined by low fuel consumption but more likely by better controllability, reliability and reduction of maintenance costs. Pure power, i.e. performance, will also be key along with cost management of the energy storage system and other integrated systems. The production series for special applications such as NRMM will probably remain quite low and thus major cost reductions at the

component level will be challenging to realise through high volumes. In addition, manufacturers might have to rethink the lifecycle management of NRMM because electrical components, and especially embedded software systems, become obsolete faster than conventional technology.

7.1.7 Acknowledgements

The authors would like to acknowledge the technical and financial support of the ECV-Tubridi project, which is financed by the Finnish Funding Agency for Technology and Innovation (Tekes).

7.2 Fully electric machinery for ports

Authors: Ville Kaivo

Affiliations: Cargotec Finland Oy

Contact information for main author: ville.kaivo@kalmarglobal.com

Abstract

Along with the use of hybrid power sources, interest in fully electrically powered horizontal transportation at port terminals has never been higher. Whether driven by environmental legislation, local pressure groups or pure economics, the need to reduce emissions, noise or over-complicated maintenance is growing. When implementing a quay to stacking area transportation system, essentially three all-electric alternatives exist; which of these provides most added value depends wholly on the characteristics and requirements of the application.

At automated container terminals utilising automated stacking cranes (ASC), the two choices are the flatbed automated guided vehicle (AGV) or the shuttle carrier (SHC) which can be manually operated or fully automated. As container movement between the quay and the container yard is a potential “bottleneck” at the terminal, the all-electric Kalmar SHC offers a major advantage by fully decoupling activities at both ends. Various derivatives of the AGV offer decoupling at the ASC, but coupled operations at the ship to shore crane (STS) can still limit productivity.

In a straddle carrier terminal, waterside and landside operations are already fully decoupled with a single machine handling both horizontal transportation and stacking. The speed, reach and flexibility of the Kalmar FastCharge™ straddle carrier (FSC) allows terminals to use a single type of equipment either manually operated or fully automated for all container operations.

The majority of all electric AGVs presently in use utilise lead acid accumulators, which due to the long charging times require automated battery replacement and charging stations. Newer technology lithium ion power sources, as used in the Kalmar straddle and shuttle carriers, are now so fast to charge that the battery stays in the vehicle and replacement is unnecessary. There is no ‘one-size-fits-all’ solution, resulting in the need to be aware of the actual performance, characteristics and parameters of each unit, to ensure an objective evaluation is achieved. This white

paper attempts to provide an objective comparison between the systems in order to help determine which concept is the better fit for given terminal.

7.2.1 Introduction

Global container volumes handled have increased year on year for decades as a result of globalisation, economic growth and geographical distribution of operations. Container transport costs have decreased considerably due to economies of scale by continuously increasing vessel sizes from 4,000 TEU in the early 1990s to 14,500 and above today. Larger container ships place an increasingly heavy demand on the terminal infrastructure to handle the growing numbers of containers moving to and from the quayside. Time is money and as the container ship only really makes money while at sea, the berthing time at the terminal quay needs to be as short as possible. This can only be achieved by fast loading and unloading which requires tight cooperation between the quayside ship-to-shore (STS) cranes and the container stacking area. For many years, the straddle carrier and terminal tractors with one or multiple chassis were the default options for horizontal transportation with straddle carriers capable of handling both horizontal transportation and stacking. To date, Kalmar has manufactured more than 5000 straddle carriers as well as delivering the world's first automated straddle carrier, the Kalmar AutoStrad™, in 2005, **Figure 108.**

Automated straddle carrier

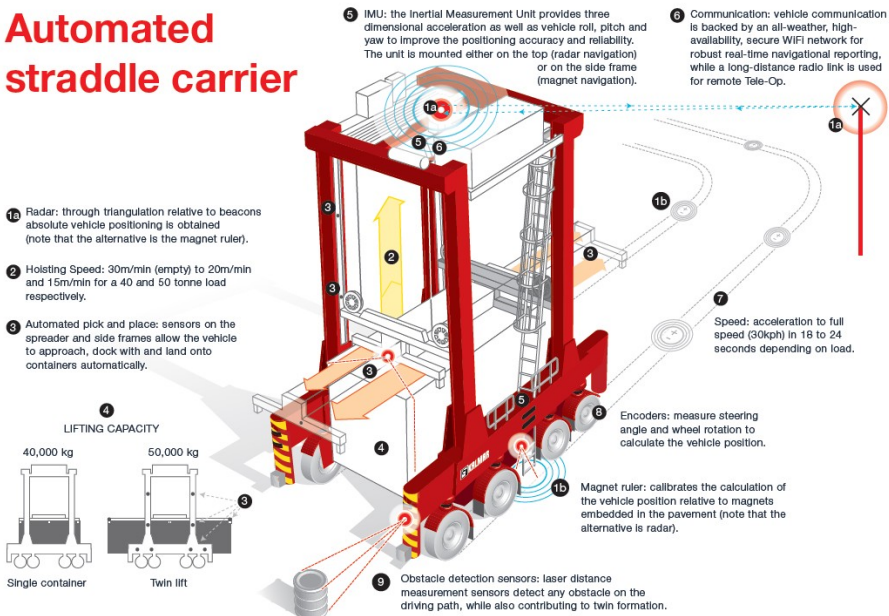

Figure 108. Horizontal transportation.

In the early 1990s, the flatbed AGV was the first driverless horizontal transportation system introduced at terminals. While many improvements have been made since, the flatbed AGV is basically an automated version of the chassis used for horizontal transportation at that time. Today, the high productivity of quay cranes can be limited by the AGVs need to be present to load and unload containers, coupling the work cycles of the quay and yard cranes.

Even with developments such as the active lift AGV, operations are still only partially decoupled at the stacking area. As a rough guide, the coupled operation at the STS crane requires a minimum of 5 AGVs to be deployed for each STS crane. A proposed cassette AGV also promises decoupling at the quay with a portable cassette, however with no existing commercial installations; how cassette placement is to be achieved in the dynamic environment at the STS crane remains unclear. The ideal decoupling buffer is created by placing the containers on the ground at the STS crane to be picked up and dropped on the ground at the automatic stacking crane (ASC) stacking area, **Figure 109**. This is where interest in the shuttle carrier as a form of horizontal transportation originated, by fully decoupling STS and ASC activities, one shuttle carrier can achieve the same productivity as two AGVs. This decoupling adds buffer zones both at the STS and ASC, making exception handling, whether caused by delays in loading or unloading, easier to manage.

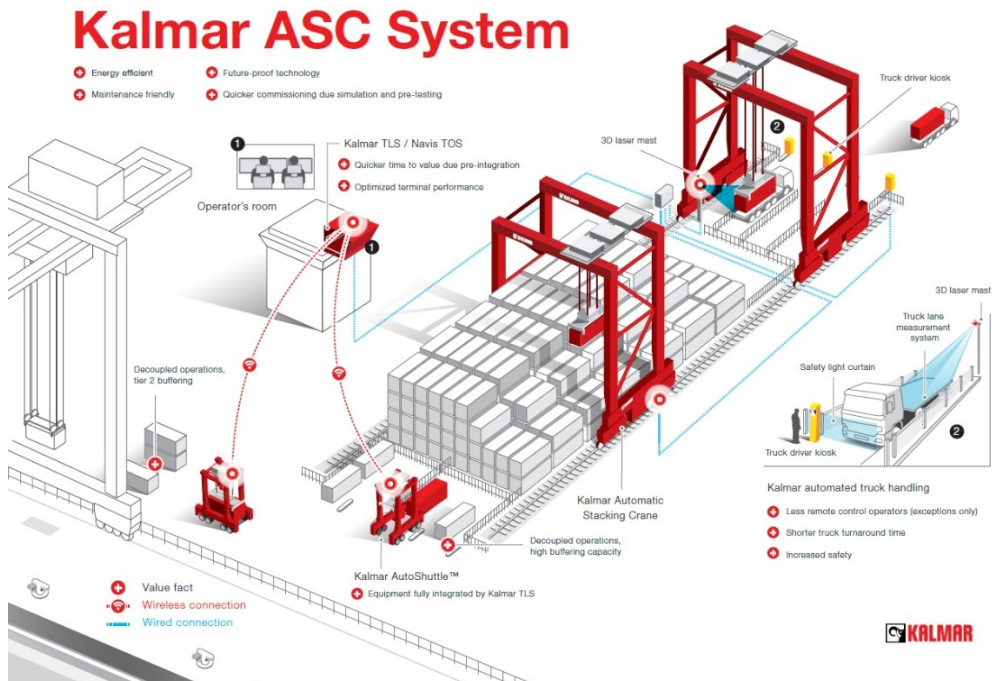

Figure 109. Automatic stacking crane system.

The innovative 'shuttle carrier' concept developed by Kalmar, a smaller 1 over 1 stacking version of the straddle carrier, was first tested at the port of Helsinki in 2003. The Kalmar AutoShuttle™ (ASHC) is able to transport single 20 and 40-foot containers, picked up from the ground, as well as two 20' boxes in a twin-lift operation. With the ability to pick up any container rather than only the outermost and to stack containers two high, the ASHC offers more versatility, especially in pooled allocation schemes serving more than one STS crane and dual cycle operations with simultaneous loading and unloading. Whether fully automated or manually operated the shuttle allows faster fully decoupled container transfer in the terminal.

Hybrids

Today, both AGVs and shuttle carriers offer electric propulsion using a diesel engine as the main power source. Diesel/electric propulsion has the same advantages as diesel but is generally more reliable and requires less maintenance. Diesel/electric has also seen the introduction of hybrid designs much in the same way as cars, allowing a much smaller engine with batteries or super capacitors supplying peak load capacity. New battery technology allows the engine to be sized for average power, whereas use of the lower energy storage super capacitors requires a larger engine sized for maximum peak demand. These designs also feature regenerative energy systems to convert braking and spreader lowering energy into electric power that is stored for later use. Using an automated stop-start system enables optimal balance between engine and battery power, which also extends engine and generator lifetimes as well as maintenance intervals. Consuming up to 40% less fuel than existing shuttle carriers on the market, Kalmar hybrid shuttle carriers with lithium batteries emit over 50 tons less CO₂ per year than a conventional diesel machine.

7.2.2 Concept and technology

Why fully electric?

While hybrid systems provide excellent economy and lower emissions, the ultimate target is an emissions free (at least at the point of use) horizontal transport solution. As environmental legislation tightens for CO₂ and NO_x, especially the latter, electric propulsion with batteries is the only alternative. As well as no emissions to the atmosphere, other advantages include less noise, reduced maintenance with a smaller number of vehicle components and up to 50% increased energy efficiency compared to diesel/electric drive.

The fully electric AGV

Commercial use of electric AGVs since the first installation in 2013 has likely been limited by the increased investment cost of the batteries and charging facilities required. Reliant on lead acid battery technology, these AGVs require almost 10 tons of batteries to provide a useful operational working time of eight hours; actual running time is a lot less. One study quotes a moving ratio of 40% and operational

stoppage or unpowered waiting time of 60%, implying that for 36 minutes of each hour the AGV is non-productive. Recharging requires removal and replacement of the battery, which although fully automated requires the AGV to be driven to the exchange station and remain inactive while the battery is replaced. As recharging takes at least six hours, at least three battery packs are required for two AGVs; at an all-electric installation in Rotterdam, a total of 87 battery packs were initially supplied for 37 electric lift AGVs with two robotic battery exchange stations. Development of the all-electric AGV required a redesign of the vehicle chassis to accommodate the weight of the batteries and distribute the load uniformly to all four wheels. Newer designs based on fast charge battery technology have been announced, but at the time of writing, details of actual operation and charging methods have not been disclosed.

New technology battery

Lithium ion (Li-ion) battery technology, first proposed in the 1970s, today powers everything from phones and personal computers to electric cars and buses. Li-ion development has been rapid and, unlike its 150-year-old lead acid counterpart, has seen a steady progression in performance and capacity with recent developments providing the advantage of extremely fast charging. Opportunity charging in public transportation, such as large capacity electric buses, uses this high charging capability to partly recharge the battery in as little as 15 seconds while passengers are disembarking and embarking at bus stops.

Compared to lead acid, these batteries offer up to 80% weight savings for the same capacity and have a much better low-temperature performance with 80% of full capacity still available at minus 30 °C. In addition to the enhanced efficiency and energy-conserving qualities of Li-ion batteries, this technology offers a high level of safety compared to alternative options. Being entirely free of carbon they avoid thermal runaway or overheating which is a main cause of fires in conventional energy storage systems.

The higher cost of lithium ion batteries when used in a fully decoupled shuttle operation is partially offset due to the fewer number of vehicles required compared to the partially decoupled operation with AGVs. Whether using a battery changing station or fast charge technology, twice as many AGVs are still required to achieve the moves per hour capability of the shuttle. One manufacturer has announced the use of Li-ion batteries in a terminal trailer concept and promises a run time of 12 hours, however the battery then has to be charged for two and a half hours, during which time the vehicle is non-productive.

The Kalmar all electric FastCharge™ shuttle and straddle carrier

Freed from the lead acid six to eight hour charge cycle, the lighter faster charge batteries have allowed Kalmar to replace diesel engines in shuttle and straddle carriers without a weight penalty, offering tremendous practicality advantages with the existing vehicle designs. Experience of the batteries already used in Kalmar's hybrid

straddle carrier have enabled engineers to optimise battery capacity and, in vehicle charging supplemented by regenerative systems, to store reclaimed braking and spreader lowering energy. Available in both manually operated and automated versions, the Kalmar FastCharge™ shuttle and straddle carriers offer a truly flexible concept for existing and greenfield terminals. In hybrid terminals, where ASCs are being partially introduced they offer the unique opportunity for gradual expansion while retaining fully decoupled container transfers. When modernising a terminal with automation as is increasingly the case, existing manual shuttles and straddle carriers can be fully automated leading to improved return on original investment and optimised total cost of ownership.

7.2.3 Solutions

Fast charging

Battery charging of the Kalmar FastCharge shuttle carrier (FSH) in automated operation is achieved with an inverted pantograph direct current charging system, totally automatic in operation and similar to that used in electric buses, **Figure 110**. Location of the current collector on top of the shuttle adds to the safety of the solution and protects it from damage. This may be another reason why Li-ion technology is not used in AGVs, as charging would be at ground level and very difficult to reliably automate. Non-contact methods such as inductive charging have also been investigated but are unable to deliver the power required without considerable energy loss. Fast charge battery technology enables very high charging rates scalable up to 600 kW, allowing rapid on-board charging. A single pantograph located on the FSH route can serve several vehicles as charging is very flexible. Since the driving cycles are short, frequent thirty-second charging periods depending on the shuttle cycle and state of battery charge do not slow container transfers and enable the vehicle to be utilised to its maximum effectiveness, see **Figure 111** and **Figure 112**. The impact of fast charging to the local power grid, in terms of electricity quality, is minimised with an intelligent charging system control. This more frequent charging avoids the deep discharge, which can shorten the life of any battery. Pantograph charging terminals can also be more easily positioned than battery exchange stations, with convenient locations on shuttle routes to eliminate disruption of the shuttle work cycle.

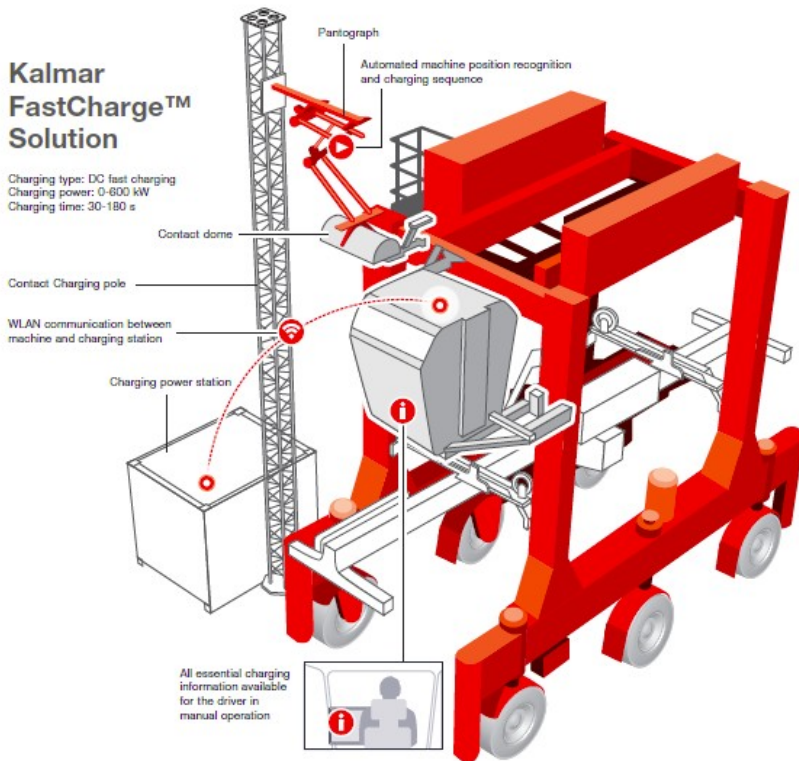

Figure 110. The Kalmar FastCharge solution enables electrically powered operation with only minor changes to existing products.



Figure 111. Fast charging stations can be installed along the working route in order to utilise idle time for charging.

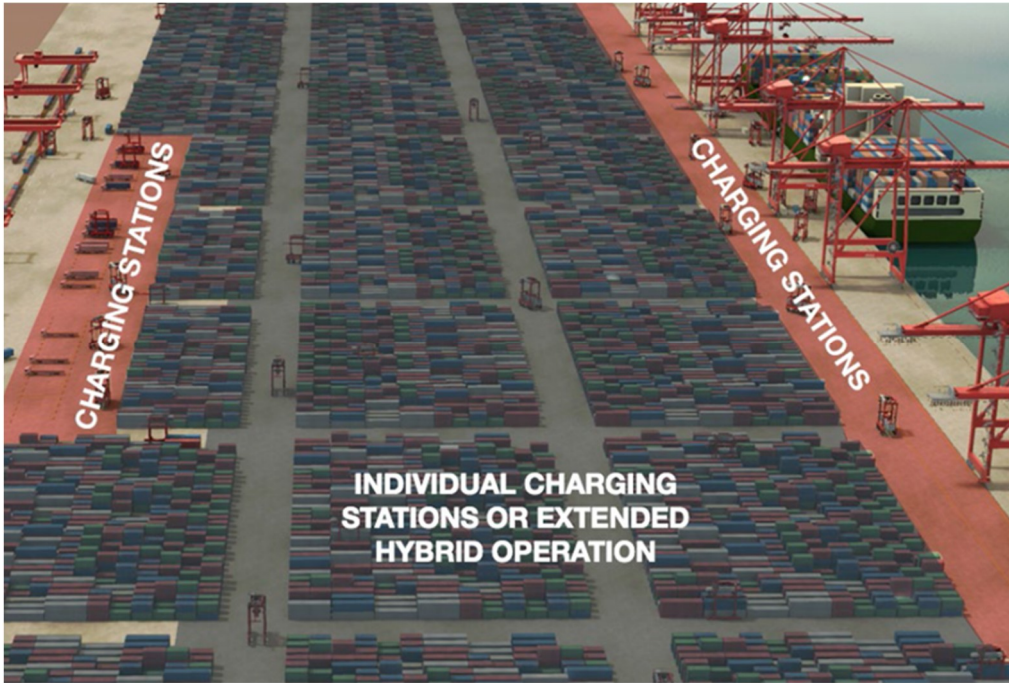



















Figure 112. The straddle carrier terminal offers highly flexible options charging station installation.

Electric AGV and FastCharge AutoShuttle concept comparisons

As previously described, in most terminals a single FastCharge AutoShuttle is capable of almost the same productivity as two AGVs, see **Figure 113**. The reduction in vehicle numbers compensates the higher initial cost of the FastCharge solution with additional savings when the AGV charging stations are taken into account.

The AGV is highly dependent on the trouble-free operation of the robotic charging station, which typically dictates a second station to provide a degree of redundancy. Owing to the weight of batteries involved, the battery change/charging station requires very substantial foundations, which may also dictate a less than ideal location with increased travel time for charging. The FastCharge charging station requires considerably less space and several can be conveniently located on regularly used routes. Compared to a lead acid robotic battery exchange and charging station for 30 AGVs, the cost of the FastCharge station for 15 equally productive shuttles is approximately 80% less when building costs are included.

Terminal A (Europe)	Terminal B (Europe)	Terminal C (Americas)
 x 11	 x 8	 x 8
 x 26 Shuttle carrier	 x 22 Shuttle carrier	 x 27 Shuttle carrier
Ratio 2,4 	Ratio 2,8 	Ratio 3,4 
Terminal D (Europe)	Terminal E (Europe)	Terminal F (Americas)
 x 15	 x 11	 x 14
 x 84 AGV	 x 62 Lift AGV	 x 72 AGV
Ratio 5,6 	Ratio 5,6 	Ratio 5,1 

NOTE! In some terminals Shuttle Carriers are used in land side operations as well

Figure 113. Comparison of fleet sizes using either shuttle carriers or AGVs in some ports.

Practicality is another area where the FastCharge AutoShuttle scores highly by using a tried and trusted vehicle design. Unlike the AGV, where the vehicle was designed around the battery, tried and proven features of the diesel/electric and battery assisted hybrid shuttle carriers were used in the development of the all-electric model. As well as shortening development time, this allowed Kalmar engineers to focus on the new technology aspects and avoid redesign of the whole concept.

Battery lifetime is a serious consideration in the purchase of any electric vehicle. Typically, battery manufacturers quote lifetime in cycles, for lead acid deep cycle batteries this equates to between 400 and 800 cycles, depending on the degree of discharge. One AGV manufacturer promises 1200 cycles, with the recommendation that the almost 10 tons of battery per AGV is replaced every two and a half years.

By comparison, fast charge battery manufacturers quote as many as 20,000 cycles, which with the increased frequency pantograph charging method conservatively equates to a more than 10-year battery lifetime in a FastCharge solution.

7.2.4 Conclusions

When selecting a horizontal transportation solution for the modern container terminal, the choice to go all-electric needs careful consideration. When calculating the total cost of ownership, many new factors need to be taken into account as well as old criteria, such as the type and number of vehicles, which can take on a new meaning in the green terminal. Improving throughput by decoupling ship-to-shore and yard operations reduces operational compromise and allows each type of equipment to operate at its own optimum speed and best performance. The new battery technology described, only recently applicable to industrial applications, is under rapid development helped in part by its ready acceptance in public transportation. As Kalmar continues to research and develop new techniques and harness these latest innovations, we hope to make the choice easier.

7.3 Electrification of harbour machinery – TCO of battery-electric machinery

Authors: Teemu Raitaluoto, Samu Kukkonen, Mikko Pihlatie
Affiliations: VTT Technical Research Centre of Finland Ltd
Contact information for main author: mikko.pihlatie@vtt.fi

Abstract

Public transport has taken major steps towards electrification of bus services including economic sustainability. Now these innovations are being applied to other environments such as harbours and mines. Techno-economic evaluation aims to shed light on whether continuation of this development is justified and whether the business case to the end customers can be proved – since high technology innovations involve significant risk, their expected benefits must significantly outweigh their costs and perceived threats.

This article describes the costs and benefits of using battery powered electric mobile machinery in a harbour environment using the total cost of ownership (TCO) method, which takes into account all costs incurred from owning and operating the product. A secondary target for this article is to evaluate the potential of battery-electric machinery as an investment. Sensitivity analysis is performed on the developed models to expose the variables that have the most impact on the end result. Results of the viability analysis show that opportunity charging is a viable method for operating harbour machinery.

The TCO analysis revealed total costs to be much lower than those of conventional diesel machinery. In a fully electrical machine, 75% of the TCO comes from energy costs, while the remaining 25% includes the cost of battery and charging

equipment. The TCO of a fully electrical machine is roughly 56% lower than that of a comparative diesel alternative. Electrical vehicles require high utilisation to achieve the estimated costs savings because the savings accumulate from using a different energy source for operation.

7.3.1 Introduction

A study on techno-economics of public transportation electric city buses was conducted during 2014-2015. The main finding was that the total cost of ownership (TCO) calculations prove the business case behind commercial electric vehicles. A key aspect of the resulting TCO is high utilisation rate, since operating an electric bus is cheaper than operating a diesel alternative. This offsets the increased initial investment cost. Another key aspect is the concept of shared opportunity charging, in which multiple vehicles use the same charging point. The vehicle is charged more frequently – during breaks in operation – than in the conventional depot charging. In bus operations, these breaks occur naturally when the vehicle stops for a while at the end of the route. Charging could also be arranged during the short breaks at bus stops. Opportunity charging would enable a smaller battery capacity compared to conventional depot charging. Furthermore, only a portion of the battery energy content is used during the operating cycle of the vehicle, which improves the lifetime of the battery.

The results obtained from electric buses also apply generally to harbour and mining operations. As electricity is cheaper than diesel, the utilisation rate of the electrically-powered machinery should be maximised as well. Utilisation rates can be improved by using breaks in operation for charging. In harbours, breaks occur when a loaded ship leaves the berth and a new ship is docked. During this time, there are no containers to move between the ship-to-shore crane and container yard. In mining, operational breaks for load-haul dumpers (LHD) occur when rock is blasted and drilled, and new tunnels are created using other machinery.

This paper presents a TCO calculation for a harbour environment. The model takes into account the system-level benefits and costs, and focuses less on the component level. Explaining the system-level benefits to the manufacturers and operators of the fleet is essential for generalisation of battery-electric machine technology. Due to the environmental impact of diesel machinery, a need has risen to find alternative solutions. All the TCOs presented here utilise a high-power charging infrastructure (preferably a pantograph system) and lithium titanate (LTO) batteries. The operation concept is opportunity charging, which is evaluated to be more feasible than depot charging.

7.3.2 Methodology

To research the harbour environment, two interviews were conducted with a harbour equipment manufacturer and a harbour organisation. Based on these inter-

views and scientific literature, the MS Excel-based TCO models were created. Sensitivity analysis was used on the variables to expose the factors that have the most effect on the TCO. This paper was written at VTT based on earlier research done for a Master's thesis. The thesis is titled 'Prerequisites of high power charging infrastructure and fully electrical machinery implementation in harbour environment'.

7.3.3 Results

The base case values of the opportunity charging concept are shown in **Table 27**. The price of the electrically-propelled machine chassis is omitted, because there is no available data, and it is thus assumed to be equal to that of the diesel alternative's chassis. The costs of other infrastructure equipment and work besides the charger are also omitted; these costs might include e.g. upgrading the supply network. The TCO is calculated on a per hour basis. Conversely, the TCOs of buses are typically calculated on a euro per kilometre basis.

Table 27. Base case values for opportunity charging concept.

Variable	Value
Yearly usage:	5,840 h
Machinery power:	40 kW
Battery energy content:	40 kWh
Operating duration per cycle:	4 min
Battery cost:	1,000 €/kWh (LTO)
Battery lifetime:	10 years
Battery power acceptance, P/E:	6
Charger cost:	250,000 €
Charger holding period:	10 years
Fleet size:	5 vehicles
Electricity cost:	0.10 €/kWh
System energy efficiency:	75%
Interest rate:	10%
Residual value:	Zero

The resulting TCO of battery-electric harbour machinery using opportunity charging and LTO batteries is 6.11€ per hour, which is roughly half that of diesel-powered harbour machinery. The most sensitive variables are yearly usage, fleet size, and electricity price. The TCO and sensitivity analysis are shown in **Figure 114**, in which the TCO of 6.11€/h represents the base case. In the sensitivity analysis, only one variable is changed at a time while the others are kept constant. The cost of energy represents about 75% of the TCO during the useful life of the machinery, while

charger and battery represent 14% and 11%, respectively. The TCOs of diesel machinery is assumed to be 14€/h corresponding to 14 l/h consumption and 1€/l diesel price. The TCO of depot charging is about 12.42€/h.

Yearly usage (h)	2920	4380	5840	7300	8760
Total cost per hour	7,65 €	6,63 €	6,11 €	5,80 €	5,60 €
Battery size (kWh)	20	30	40	50	60
Total cost per hour	5,20 €	5,73 €	6,11 €	6,42 €	6,68 €
Fleet size	2	3	4	5	6
Total cost per hour	7,40 €	6,68 €	6,33 €	6,11 €	5,97 €
Unit cost of kWh (€)	200 €	400 €	800 €	1 000 €	1 200 €
Total cost per hour	5,56 €	5,70 €	5,98 €	6,11 €	6,25 €
Charger cost (€)	150 000 €	200 000 €	250 000 €	300 000 €	350 000 €
Total cost per hour	5,77 €	5,94 €	6,11 €	6,28 €	6,45 €
Charger lifetime (years)	6	8	10	12	14
Total cost per hour	6,68 €	6,33 €	6,11 €	5,97 €	5,87 €
Battery lifetime (years)	6	8	10	12	14
Total cost per hour	6,57 €	6,28 €	6,11 €	6,00 €	5,92 €
Electricity price (€/kWh)	0,08 €	0,09 €	0,10 €	0,11 €	0,12 €
Total cost per hour	5,20 €	5,66 €	6,11 €	6,57 €	7,03 €
System efficiency (%)	69 %	72 %	75 %	78 %	81 %
Total cost per hour	6,51 €	6,30 €	6,11 €	5,94 €	5,77 €

Figure 114. TCO results and sensitivity analysis of battery-electric harbour machinery using opportunity charging.

7.3.4 Discussion

The results show that using fully electric harbour machinery with opportunity charging and LTO batteries is highly competitive against conventional diesel-powered machinery. However, the models presented here are prone to error due to a lack of public data and uncertain operating conditions of harbours. Operational data is hard to come by for external parties. However, machine and system suppliers are increasingly aware of the operating parameters of their machines and this is direct input into their R&D. Fully electric harbour machinery are already entering the market. Furthermore, knowledge transfer between electric harbour machinery and electric commercial vehicles is certainly possible.

TCO results for the depot charging method indicate that having a large battery in each vehicle and multiple chargers at the depot site cancels out the economy of electric vehicles. Additionally, in harbours the depot is often located at a more distant location, which requires increasing the battery size even more. The long charging times of depot charging have been partially solved using the battery swap method. However, this method requires investment in more batteries. Profits from the depot charging system are not enough to compensate the high risk (assumed 10% cost of capital).

Further research should be done to validate the results of this research. This would require measuring operating cycles in a typical harbour and determining applicable prices for the equipment. Validating the results and producing case examples would prove and generalise the technology. Other options, such as battery leasing, have been discussed to mitigate the buyer's risk of new high technology.

7.3.5 Conclusions

There is potential in fully electric harbour machinery if the opportunity charging concept is used. Such a machinery is already commercially available. Although customers are already environmentally aware, the expected benefits and perceived risks must be explained to the end customer before generalisation of this new high technology.

7.3.6 Acknowledgements

Sincere thanks to Samu Kukkonen for guiding the thesis forming the foundation for this article. Deep gratitude also to Juho Leskinen, R&D engineer at Kalmar Cargotec, and Pekka Hellström, Development Manager at Vuosaari Port, for participating in the interviews and providing insightful knowledge about harbour machinery and operations.

7.4 Virtual platform for NRMM hybridisation research

Authors: Jarkko Nokka, Paula Immonen, Lasse Laurila, Juha Pyrhönen
Affiliations: LUT School of Energy Systems, Lappeenranta University of Technology
Current contact information for main author: jarkko.nokka@mevea.com

Abstract

Hybridisation is becoming an increasingly attractive option in the field of Non-Road Mobile machinery (NRMM) for cutting emission levels and improving the overall energy efficiency. Downsizing the diesel engine and introducing new components to vehicle drivelines are, however, key R&D challenges, and prototyping could be expensive and time consuming. This paper presents an NRMM hybridisation research platform capable of evaluating machine performance using virtual prototyping and co-simulation principles. A multibody dynamics based virtual model of an NRMM can be rapidly altered and the energy efficiencies evaluated in each iteration. The findings of the research, conducted using three operationally similar machines, indicate that the diesel engine of the case machines could be downsized by 50%, resulting in 50% less overall fuel consumption.

7.4.1 Introduction

Hybridisation of road vehicles has been a common trend in recent decades, along with a growing consumer interest in energy efficiency. Hybrid drivelines are, alongside fuel and engine development, reducing the cost of commuting. The development in performance and cost of battery technologies has also enabled the possibility to hybridise NRMMs. Despite the recent drops in oil prices, as experienced during the transient of 2014–2015²⁰³ price plummet, the fuel saving potential of using series hybridisation technologies to power highly dynamic machines remains attractive. Additionally, the possibility of both downsizing and optimally running the main energy source, the diesel engine, enables manufacturers to meet the ever-tightening emission regulations of the European Union²⁰⁴. The trend towards hybridisation has been increasingly visible in the industry, with many NRMM manufacturers starting to produce hybridised machinery promoting their fuel economy and power increase potential^{205 206 207 208 209}.

Even though some industrial fields – the harbour industry being a good example – have some innately hybridised concepts, in many fields hybridisation requires prototyping and testing before reliable performance and correct dimensioning of electromechanical output power and energy storages can be achieved. Building such prototypes is time-consuming and expensive. However, it has been shown that virtual prototyping can be utilised in the early to mid stages of R&D processes to reduce time requirements and costs. By utilising accurate virtual representations of NRMM, the performance of the hybrid driveline can be analysed and the system can be iterated without building actual prototypes. Even prototype drivelines can be tested against such virtual machine.

This paper demonstrates a virtual prototyping-based test platform for dimensioning and validating hybrid driveline concepts in existing NRMMs. The selected case example is the Tubridi case machine, EJC90 underground loader (driven with 90 kW diesel engine, mass close to 14 tons), for which validation data are available. Some preliminary results of the hybridisation effects are also obtained with a bigger, LH410 loader. The results show consistent fuel consumption reductions of roughly 50%, together with considerable potential for diesel engine downsizing. The fuel

²⁰³ Oil-Price.net, “Oil-Price.net,” [Online]. Available: <http://www.oil-price.net>. [Accessed 25.4.2015].

²⁰⁴ DieselNet, “Emission Standards: Europe: Nonroad Engines,” 11 2014. [Online]. Available: <http://dieselnet.com/standards/eu/nonroad.php>. [Accessed 25.4.2016].

²⁰⁵ Komatsu, “Komatsu Hybrid,” [Online]. Available: <http://www.komatsu.com.au/AboutKomatsu/Technology/Pages/Hybrid.aspx>. [Accessed 25.4.2016].

²⁰⁶ Caterpillar, “336E H Hybrid,” 2015. [Online]. Available: http://www.cat.com/en_US/products/new/equipment/excavators/large-excavators/18378156.html. [Accessed 25.4.2016].

²⁰⁷ Caterpillar, “Caterpillar D7E,” 2015. [Online]. Available: http://www.cat.com/en_US/products/new/equipment/dozers/medium-dozers/18429156.html. [Accessed 25.4.2016].

²⁰⁸ John Deere, “Wheel Loaders,” 2015. [Online]. Available: https://www.deere.com/en_US/products/equipment/wheel_loaders/wheel_loaders.page. [Accessed 25.4.2016].

²⁰⁹ ProSilva, “ProSilva 910EH Press release,” 2012. [Online]. Available: <http://www.prosilva.fi/images/stories/pdf/pressrelease.pdf>. [Accessed 25.4.2016].

consumption simulations correlate well with previous similar research²¹⁰. The main contributor to fuel consumption reduction is the engine's constant high efficiency operating point, without direct coupling with the mechanical driveline. The electrical drives in the mechanical driveline operate over a large high-efficiency area in the speed-torque plane and are well suited to the high amplitude dynamics, often present in the NRMM drivelines

7.4.2 Methods

The research reported in this paper utilises the co-simulation principle, where two or more separate simulations are connected to each other and exchange information in real time²¹¹. In the presented case these simulation segments are divided into the following

- Multi-body dynamic (MBD)²¹² simulation of the mechanics of the machine, mechanical and hydraulic driveline simulations acting as a load for the driveline
- Simulink simulation of diesel-electric hybrid driveline
- Option for Hardware-in-Loop (HIL) connectivity

The co-simulation segments are connected via IP-Socket connection and for example, the Simulink and MBD simulation can communicate with less than 1 ms delay.

An NRMM can be modelled with great accuracy using the MBD approach, where the functional components of the machine are defined by their mass and inertia properties. With certain constraints, these functional components are then interconnected with various joints (spherical, hinge...) restricting the relative movement between bodies. The MBD system can then be affected by introducing forces to the system, either from the hydraulic system, mechanical driveline or the environment and collision modelling. The propagation of these forces can then be analytically solved based on the mass, inertia and joint parameters and accurate behaviour of a real machine can be thus achieved. When studying the hybridisation effects on machine fuel consumption and operation in general, the driveline can be altered freely and shifted to a separate Simulink simulation. The mechanical driveline of the MBD simulation as well as the integrated hydraulics model get their inputs from the electrical drives in the Simulink model and respond with a feedback value, presented in more detail in **Figure 115**

The Simulink model of a hybridised diesel-electric driveline consists of models of a diesel genset, battery and two to five electrical drives and their control. The sub-

²¹⁰ Lajunen, A., Suomela, J. Evaluation of Energy Storage System Requirements, IEEE Trans. on Veh. Tech., **61**(8), 3387–3393, 2012.

²¹¹ Nokka, J., Montonen, J.-H., Bin Baharudin, E., Immonen, P., Rouvinen, A., Laurila, L., Lindh, T., Mikkola, A., Sopanen, J., Pyrhönen, J. Multi-Body Simulation Based Development Environment for Hybrid Working Machines, International Review on Modelling and Simulations (IREMOS), **8**(4), 466-476, 2015.

²¹² de Jalón, J., Bayo, E. Kinematic and Dynamic Simulation of Multibody systems: The Real-Time Challenge, New York: Springer-Verlag, 1994.

components are connected with a power flow principle, where the variable transferred, for example from electrical drive to the battery, is power instead of voltage and current. This simplifies the model and allows for more complex drivelines to be created while the real-time requirement is met. **Figure 115** presents the signal connection between the diesel-electric driveline in Simulink and the MBD and hydraulics simulation.

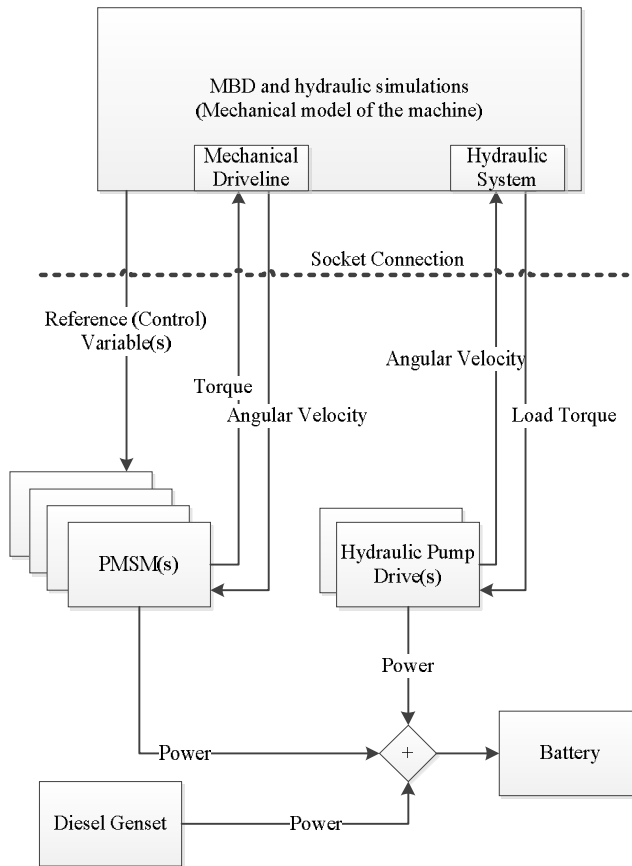

Figure 115. Co-simulation signal schematic.

The co-simulation platform provides a virtual representation of the simulated machine, where the MBD system is presented visually for the operator, **Figure 116**. The operator sits in a six-screen cabin environment, where he can operate the machine in a realistic manner in real time. Motion platform, driver head tracking and surround sounds enhance this realism, and the hybrid NRMM co-simulation environment receives more realistic input behaviour. When the component parameters are changed, the effect can be seen and felt in the operator cabin.

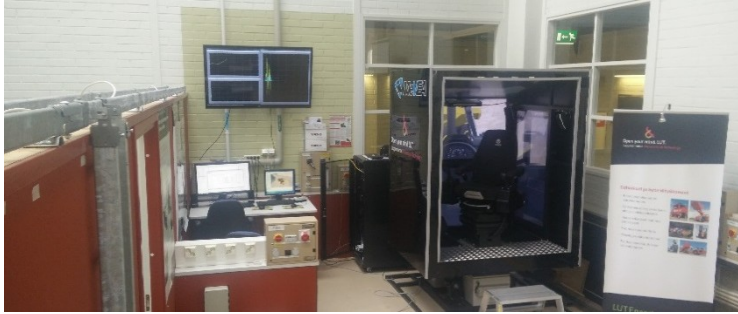

Figure 116. The NRMM simulation platform. The visualisation cabin provides a realistic environment for the operator, and the co-simulation environment provides accurate representation of the machine.

Changing load cycles are a challenge in prototyping. As the diesel engine and electrical drive vary in terms of torque and power output characteristics, the load cycle naturally changes with it. As the same load cycle measured from a diesel-powered machine cannot be utilised in evaluating hybrid driveline performance, new boundary conditions for the load cycle have to be found. In the context of the presented research, the load cycle is considered to be equivalent if:

- The length of the cycle is similar
- The route driven is similar
- The useful work done is similar

Naturally, the third evaluation restricts the performance analysis by eliminating the possibility of increasing the working performance but, on the other hand, it reduces the free variables in the system and gives a more accurate estimation of the fuel efficiency increase.

The main benefit of the presented co-simulation platform is that the parameters of the NRMM – whether hydraulic, mechanical or electrical – can be rapidly altered and the effects seen right away, without any prototypes built. The introduction and dimensioning of hybrid drivelines can also be done fast and – as presented in the results section – for example fuel consumption comparisons of a certain NRMM can be made: two of these fuel consumption analyses done with virtual NRMM models are presented, including also a model verification based on actual measurements.

7.4.3 Results

Throughout the Tubridi project, a number of different NRMM cases were researched. In this paper, two underground loaders are presented: a fairly standard sized LH410 and the Tubridi case NRMM – EJC90.

7.4.3.1 LH410 underground loader

The LH410 is a fairly standard sized underground loader, weighing roughly 26 tons, and has proven to be a good initial target for hybridisation analysis. The mechanical driveline of the hybridised machine was left unchanged, and the machine can be interpreted as a conversion hybrid. The original 200 kW diesel engine was removed and a diesel-electric driveline was added with electrical drives applying power to the mechanical and hydraulic drivelines. The electrical drive responsible for the tractive power was a 66 kW PMSM, and the genset consisted of a 66 kW VW diesel engine connected to a similar 66 kW generator. The battery pack is a 36 kWh Li-ion pack, more than capable of producing the power needed in the traction. The genset was iterated to operate at roughly 37 kW of constant power.

A professional driver was invited to drive test cycles with both the original and hybridised loader in two different route lengths, the shorter being a more typical haul length and the longer representing the EJC90 route measured. Energy and work efficiencies were then calculated and initial results were examined on the spot. **Figure 117** and **Figure 118** present the average fuel consumption comparison between the machine types for the shorter and longer route, respectively.

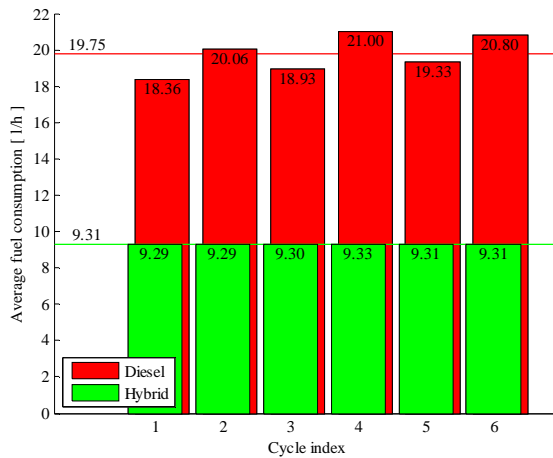

Figure 117. Simulated average fuel consumption: 100 m route.

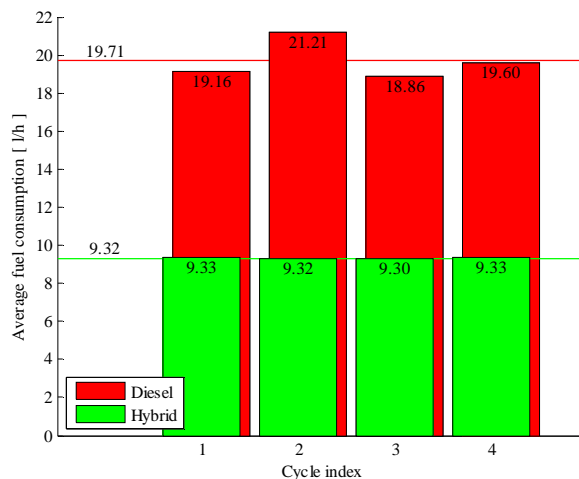

Figure 118. Simulated average fuel consumption: 378 m route.

As can be seen in the above figures, series hybridisation and optimal dimensioning of the diesel engine resulted in an approximately 50% increase in machine fuel economy. This trend continued throughout the cycle recording session and constantly gave the same result in all 20 cycles driven, divided between the two topologies. The driver gave an oral estimation that the fuel consumption of the diesel-powered LH410 would be in the range of 20 litres per hour for a real-life machine. The work efficiency remained the same, regardless of the hybridisation. The duration of cycle and hauled tonnages averaged the same figures, thus a fuel efficiency comparison between the hybrid and original machine was possible.

7.4.3.2 EJC90 underground loader – model and method verification

The EJC90 machine case is used, in addition to hybridisation research, to verify the modelling and simulation principles. EJC90 is a 14-ton underground loader powered by a 90 kW diesel engine. The verification was done with actual measurement data of the machine operating in a typical drive cycle in a mineshaft. The simulated drive cycle replicated the measured drive cycle, thus a comparison of the virtual and real machine could be made and conclusions about the modelling principle accuracy drawn. The tractive driveline was constructed as hydraulic, as presented in **Figure 119**. The structure of the working hydraulics is presented in **Figure 120** in simplified form.

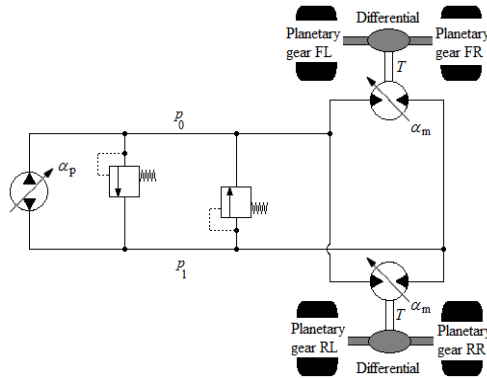

Figure 119. Original drive transmission model used in simulations.

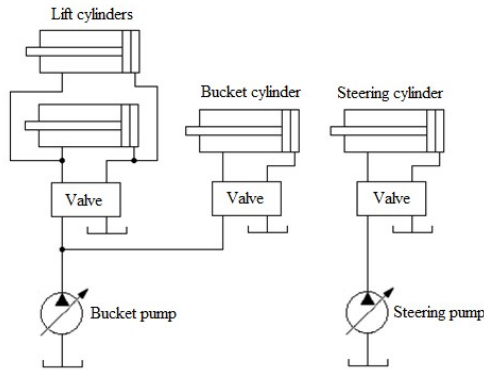

Figure 120. Working hydraulics model used in simulations.

In the work cycle, the loader is driven to the bottom of the mine where a 2300 kg rock load is loaded into the bucket, brought back up and unloaded to conclude the cycle. The work cycle includes idling periods at both the beginning and end of the cycle to match the recorded cycle. **Figure 121** presents the vehicle speeds during the work cycles, both measured and simulated.

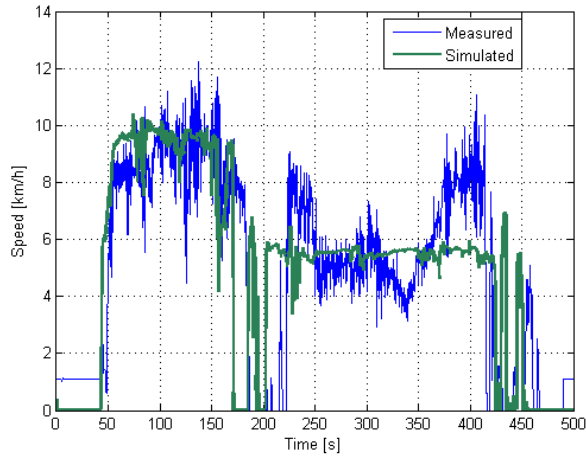

Figure 121. Measured and simulated vehicle speed during the work cycle.

The model verification is based on the comparison of fuel consumptions and the energy integrals required from the diesel engine, in addition to speed and power curve matching. **Table 28** presents these comparative figures.

Table 28. Measured and simulated energy and fuel consumption during the work cycle.

	Measured	Simulated	Difference
Energy demand for diesel engine [MJ]	22.9	21	8%
Fuel consumption of work cycle [l]	2	1.9	5%
Average fuel consumption [l/h]	14.4	13.7	5%

The simulated and measured fuel consumptions correspond quite closely with a difference of only 5%, and the rough requirement of less than 10% error is also achieved in the energy integrals, at 8%.

Hybridisation of the EJC90 started with an initial, rough estimation of what the driveline will eventually be, and remains under continuous development. The battery is a 14.5 kWh Li-ion pack, the rear axle is driven by a belt gear, the gear box and final gear by a 85 kW induction motor, the front axle by a belt gear, and the final reduction gear by 67 kW induction motor. The genset (2 l diesel engine – 85 kW synchronous generator) operational point was iterated to 31.5 kW. An example drive cycle of the hybridised EJC90 can be seen in **Figure 122**. The hybrid driveline could utilise regenerative braking in the downhill section of the cycle, as well as when decelerating the machine. The mechanical brakes, even though available, saw relatively little use. All of the regenerated electrical energy was stored in the energy storage. The combined graph of fuel consumptions driven with the hybridised

EJC90 (15 cycles) is presented in **Figure 123**. Comparison with the simulated fuel consumption of the unhybridised original EJC90 is also made.

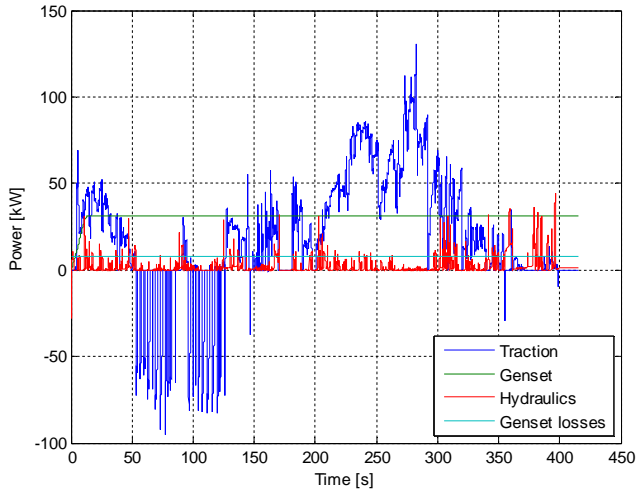

Figure 122. Simulated powers of the hybridised EJC90. The average fuel consumption of the diesel genset at the 31 kW operational point is approximately 7.9 l/h

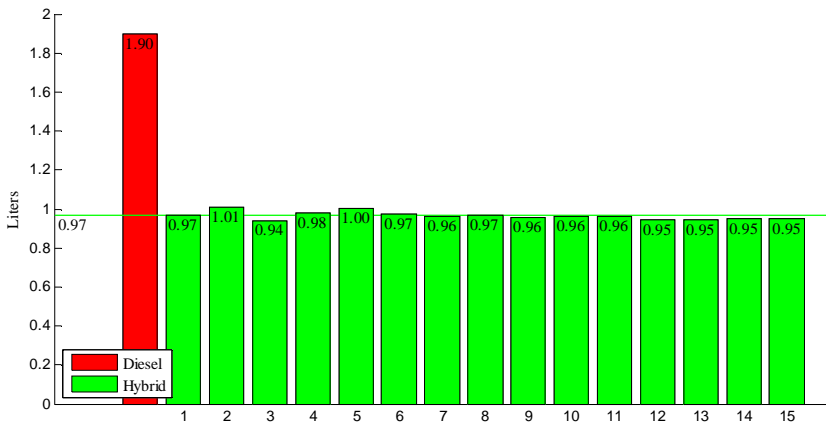

Figure 123. Fuel consumption comparison between hybridised and unhybridised EJC90 variants. The diesel variant shows the result of the verification cycle presented earlier in this section. The hybrid cycle is repeated 15 times to reduce variation in the results.

The results presented in **Figure 123** show that on average hybridisation reduces fuel consumption by 49%. The diesel engine could be driven at an optimal operational point throughout the cycle, providing maximum fuel efficiency. The average cycle length of the hybrid variant matches the approx. 400 s cycle length of the diesel variant. The results in **Figure 123** take into account the SoC difference in the battery at the end of the simulation compared to the start. On average, 1% of battery capacity was gained in one cycle, representing roughly 40 ml of diesel oil consumed in the genset at the selected operational point.

7.4.4 Discussion

Two different machine cases were analysed in the context of this paper. Both of the presented machines have shown an approximately 50% reduction in both fuel consumption and installed diesel engine power when implementing the series hybrid driveline, all without producing negative impacts on the operational performance of the machine. A novel method of iterating, dimensioning and testing has been presented, and with the case example of the Tubridi project EJC90 underground loader, the modelling and simulation methods were also verified. The initial results from the hybridised EJC90 also show similar behaviour in terms of fuel efficiency and working efficiency as the two previous cases of LH410 underground loader and the wheel loader presented in the results section.

Both of the presented simulation methodologies were proved valuable and resulted in significant findings. Vast savings in fuel consumption in combination with the decreasing trend in battery and electrical drive pricing make hybridisation an increasingly attractive choice as payback times continue to shorten. The presented co-simulation environment makes the whole development process of new machine and driveline concepts faster and more cost efficient. The prototype machine can be iterated and test driven before the actual prototyping has even started. New boundary conditions of the work cycle itself should also be considered when simulating hybrid machines, since the power demand changes dramatically when introducing (especially multiple) electrical drives to an NRMM driveline. The hybridisation platform is a cost-effective way of determining the benefits of hybridisation in various NRMM. Since producing new prototypes is costly and time-consuming, this kind of platform could significantly speed up the R&D processes in the industry. Designing and building prototypes for a new product typically takes several years in the industry. Building a sophisticated virtual machine takes only some weeks or months and can save at least one real prototype cycle in a machine design, thus significantly speeding up product development.

7.5 Full-scale series hybrid mining loader with zonal hydraulics

Authors: Teemu Lehmuspelto, Panu Sainio, Otto Tammisto, Tatiana Minav, Matti Pietola

Affiliations: Aalto University

Contact information for main author: panu.sainio@aalto.fi

Abstract

In this paper, results of the Tubridi project 2012–2015 and EL-Zon project from autumn 2015 onward are presented. A full-scale mining loader powertrain prototype was built to exploit the benefits of a series hybrid electric powertrain with low traction requirements with a combination of decentralised, e.g. zonal, hydraulics. Correspondingly, this paper introduces the structure of the mining loader and the hydraulic lifting/tilting system realised with direct driven hydraulics (DDH).

7.5.1 Introduction

Interest in electric and hybrid electric propulsions are continuously growing due to environmental concerns and government regulations and the search for higher productivity and power. Many governments around the world have set tight CO₂ emission rules²¹³, and new exhaust limits for engine manufacturers have just been implemented, such as Tier 4 / EURO VI. In particular, non-road mobile machinery (NRMM) is a promising and challenging field of electric applications due to the nature of their duty cycles^{214, 215} which can include high and short power peaks and extreme working conditions^{216, 217} (for further background research see^{218, 219, 220, 221}). Interest in and need for the electric and hybrid proposal continue to grow, and the research community has responded in kind. In Finland, the university-funded 2008–2012 HybLab loader project laid the foundation for further pioneering research in

²¹³ Tier 4 Emission Standards for Nonroad Diesel Engines, online, <https://www.dieselnet.com/standards/us/nonroad.php#tier4>.

²¹⁴ Lajunen A., Sainio P., Laurila L., Pippuri J., Tammi K. Evaluation of hybrid and electric powertrains in non-road mobile machinery, ECV seminar 2015.

²¹⁵ Minav T.A., Heikkinen J.E., Sainio P., Pietola M. Direct Driven Hydraulic Drive for New Powertrain Topologies of Non-Road Mobile Machines, Elsevier, Electric Power System Research, under review.

²¹⁶ Avadikyan, A., Llerena, P. 2010, A real options reasoning approach to hybrid vehicle investments, *Technological Forecasting & Social Change*, **77**, 649–661, 2010.

²¹⁷ Weber, J. *Automotive Development Processes, Processes for Successful Customer Oriented Vehicle Development*, Springer 2009.

²¹⁸ Kaikkonen, I. The Hybridization of powertrains in the Mobile Heavy Machinery Industry, and Changes in Industry Architecture (Hybridi voimalinjat työkoneissa ja muutokset toimiala-arkkitehtuurissa), M.Sc. thesis, Aalto University, 2012.

²¹⁹ Tammisto, O. Electrification of Agricultural Machines, M.Sc. thesis, Aalto, 2014.

²²⁰ Lehmuspelto T., Heiska M., Leivo A., Hentunen A., Hybridization of a Mobile Work Machine, *World Electric Vehicle Journal*, **3**, ISSN 2032-6653 – 2009 AVERE.

²²¹ Lehmuspelto T., Heiska M., Leivo A., Modular driveline concept for underground mining loader, *World Electric Vehicle Journal*, **4**, ISSN 2032-6653 – 2010 AVERE.

this area, and the Tubridi and EL-Zon projects funded by the Finnish Funding Agency for Technology and Innovation (Tekes) have continued the development of electric and hybrid proposals for working machinery. This paper presents the results of the Tubridi project (2012–2015) and EL-Zon project (from autumn 2015). During these projects, a full-scale mining loader powertrain prototype was built to exploit the benefits of a series hybrid electric powertrain with low traction requirements with a combination of decentralised, e.g. zonal, hydraulics.

7.5.2 Test setup

Figure 124 illustrates a conventional mining loader equipped with hydrostatic transmission. Each axle had its own hydraulic motor, connected parallel in the hydraulic circuit. The hydraulic transmission circuit was equipped with a flow divider to allow speed difference between the axles and also a locking feature to prevent free wheel spin when the axle is in the air, e.g. during loading. This type of mining loader is characterised by a rigid mechanical connection between the axles, which results in energy loss through internal counterforces, pumping losses, etc. In that sense, the loader's original drivetrain can be seen as advantageous. The adjustable main pumps were driven by a constant speed diesel engine. This conventional topology results in additional losses in these types of machines. In addition, this type of articulated vehicle with frame-steering presents challenges with respect to directional instability (jack-knifing) especially at higher speeds and a general risk of toppling if heavily steered with a raised, loaded bucket.

Therefore, in order to eliminate these losses, decrease energy consumption and improve controllability, a series hybrid mining loader with electromechanical steering^{222,223,224} and DDH was created.

²²² Cournout, P. Electromechanical steering for the hybridization, Internship report, Aalto University, 2010.

²²³ Lehtinen, T. Electromechanical steering for an articulated mobile work machine, M.Sc. thesis, Aalto University, 2013.

²²⁴ Muhli, J. Retrofitting electromechanical steering on frame-steered non-road mobile machine, M.Sc. thesis, Aalto University, 2013.



Figure 124. A 14-ton serial hybrid mining loader.

A novel concept of decentralised, e.g. zonal, hydraulics for the hybridisation of the working hydraulics of a mining loader was also introduced. This concept is based on the direct driven hydraulics (DDH) approach^{225,226,227,228,229,230,231}, which combines the benefits of electrical engineering with hydraulics.

7.5.3 Main powertrain

In the Tubridi research project the mining loader's original hydraulic transmission was replaced with a fully electromechanical transmission. Both axles have their own electromechanical drive units and there is no mechanical connection between the axles. Electric power is produced by a diesel engine driven generator and buffered with a li-ion battery. The diesel engine has no mechanical connection to the drivetrain, thus the drivetrain architecture is series hybrid. **Figure 125** shows the system layout of the developed electric hybrid mining loader. The main power is supplied through a 650 V fixed voltage DC-link which connects all sub-systems together. All subsystems have their own fully controllable power electronic device between the DC-link and the subsystem. The electromechanical drivetrain is dimensioned so that the four-speed rear axle drive unit produces the main traction power and high torque in a loading situation. The front axle drive unit has a fixed gear ratio and its role is to assist the rear axle drive unit by keeping traction on when the rear

²²⁵ Mylläri, A. High speed electric motor in diesel-electric hybrid mobile machinery (Suurnopeuksisen sähkömoottorin käyttö diesel-sähköisessä hybridityökoneessa) M.Sc. thesis, Aalto University, 2012.

²²⁶ Bonato, C. Position Control and Overall Efficiency of Electro-Hydraulic System, M.Sc. thesis, Aalto University, 2014.

²²⁷ Kiesi, M. Suorasähkökäyttöisen hydraulijärjestelmän paineakun valinta ja mitoitus, BSc thesis, Aalto University, 2014.

²²⁸ Bonato C., Minav T., Sainio P., Pietola M. Position control of direct driven hydraulic drive, Symposium of FPNI, June 2014, Lappeenranta, Finland, 2014.

²²⁹ Minav T.A., Sainio P., Pietola M. Direct driven hydraulic drive without conventional tank, ASME/Bath fluid power conference, September 2014, Bath, UK, 2014.

²³⁰ Minav T., Pietola M. Position Control of Direct-Driven Hydraulic Drive without Conventional Oil Tank for More Electric Aircraft, MEA2015, Toulouse, France, 2015.

²³¹ Minav, T., Sainio, P., Pietola, M. Efficiency of Direct driven hydraulic setup in arctic conditions, SICFP 2015, May 2015, Tampere, Finland.

axle drive unit's transmission is shifting, when the rear axle is in the air, or when rear wheels are slipping. The electric production and buffering are dimensioned so that full performance can be achieved with only gen-set or with only battery. This gives the possibility to drive the loader's test cycle either fully electric battery operated or fully diesel-electric operated with a high performance profile. A pure hybrid drive dimensioning basis allows even further downsizing of the diesel engine. This is possible because the average power demand over a typical duty cycle is relatively low compared to the power peaks needed to perform the duty cycle. Both gen-set and battery give about 70 kW electric output power to the DC-link. The battery is also capable of charging-in all the braking energy available on downhill drives. When the battery is full or otherwise incapable of charging, recharge energy is dissipated via the brake chopper to the brake resistor.

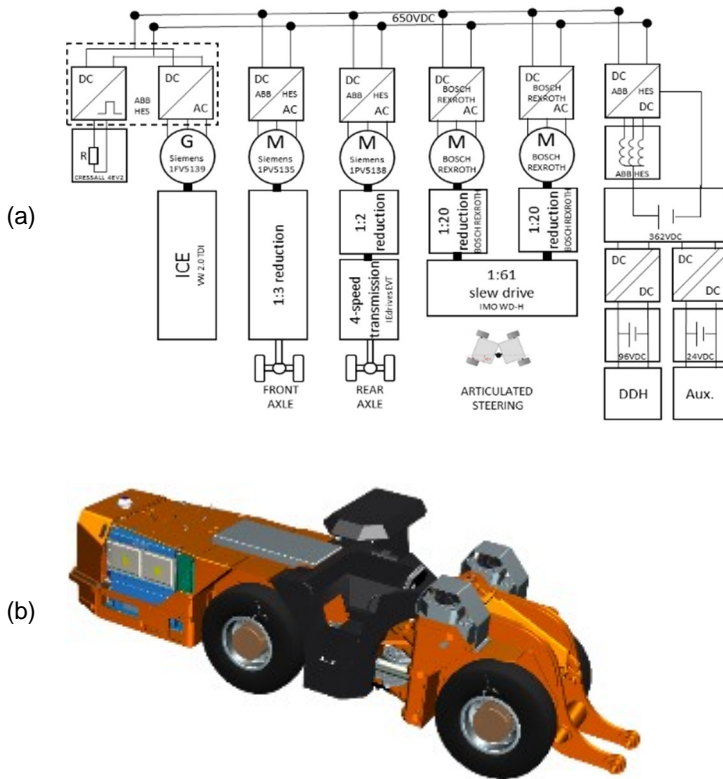

Figure 125. A 14-ton serial hybrid mining loader (a) schematics, (b) CAD drawing²³².

²³² Minav, T.A., Bonato, C., Sainio, P., Pietola, M. Efficiency of Direct Driven Hydraulic Drive for Non-road Mobile Working Machines, at ICEM, September 2014, Berlin, Germany, 2014.

The powertrain subsystems consist of the gen-set, 24 V / 96 V / 362 V batteries, front and rear axle electromechanical drive unit, electromechanical steering system, direct drive hydraulics (DDH), auxiliary systems and low & high voltage DC-links. **Figure 126** illustrates CAD drawing of the loader without and with body parts.



Figure 126. CAD drawing of the loader without and with body parts.

The gen-set has a VW 75 kW 2.0 diesel engine, 85 kW Siemens PMSM generator and ABB HES 880 Inverter (**Figure 127**). The inverter has an integrated brake chopper for over voltage protection in a 650 V DC-link. The brake chopper is connected to a 100 kW Cressall 4EV2 water-cooled resistor unit. When the generator's and inverter's efficiencies are taken into account, the gen-set output power to the DC-link is about 70 kW. Best efficiency is at around 1600-1900 rpm, which gives about 45-55 kW. This is suitable in hybrid mode, when compared to the original performance.

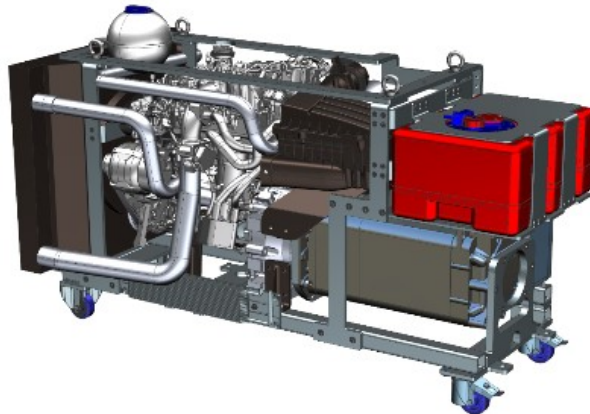

Figure 127. CAD drawing of the gen-set with VW-2.0TDI 75 kW diesel engine and Siemens 85 kW PMSM generator.

Figure 128 illustrates high voltage battery packs used in the 14-ton hybrid mining loader. The high voltage storage has a nominal 362 V Li-ion battery based on 98x

Kokam 40 Ah cells and Elithion BMS, ABB HES choke and ABB HES 880 DC/DC-converter. The battery is capable of up to 200 A constant and 400 A peak currents. This gives about 72 kW constant power and 144 kW peak at nominal voltage level. The DC/DC-converter limits the current to 300 A so the maximum battery power to drivetrain is about 110 kW. When the DC/DC converters and choke efficiencies are taken into account, the battery output power to the DC-link is about 70 kW constant and 105 kW maximum. The battery has a total capacity of about 15 kWh. The specified full lifetime requires maximum 80% usage of the capacity, which reduces the useful capacity to about 12 kWh.



7x cell in series battery module
Kokam SLPB 100216216 - 40 Ah



362 V battery has 14x Kokam battery modules in series (=7x14=98 cells in series)

Figure 128. High voltage battery packs used in the 14-ton hybrid mining loader.

The rear axle electromechanical drive unit has an 85 kW (max. 150 kW 1 min) Siemens ASM motor, 1:2 synchronous belt drive reduction gear, 4-speed IEdrives EVT transmission and ABB HES 880 Inverter²³³. The 4-speed transmission has electromechanical shifting actuators, which are controlled with an external controller. Shifting also requires synchronisation controls for the traction motor to adjust the speed

²³³ Liljeström, J. Electromechanical transmission challenges in non-road mobile machinery drivetrains (Sähkömekaanisen voimansiirron haasteet työkoneiden ajovoimainjoissa). M.Sc. thesis, Aalto University, 2014

between the traction motor and output shaft. The rear axle oscillates, causing sideways movement to the axle input. This requires a drive shaft between the transmission and the axle input. The drive shaft is a GKN constant velocity drive shaft. **Figure 129** shows a CAD drawing of the electric motor with 1:2 belt drive, 4-speed gearbox and rear axle of the mining loader.

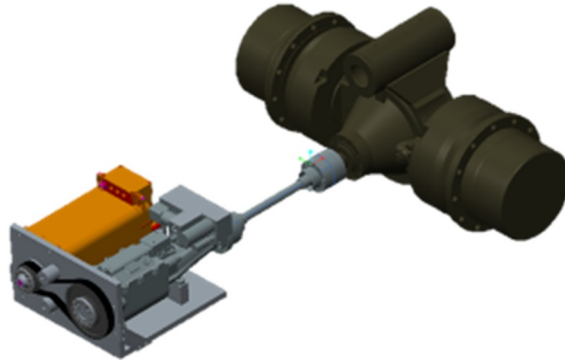

Figure 129. CAD drawing of the electric motor, 1:2 belt drive, 4-speed gearbox and rear axle of the mining loader. Note: belt-driven gearing.

The front axle electromechanical drive unit has a 67 kW (max. 150 kW 1 min) Siemens ASM motor, 1:3 synchronous belt drive reduction gear between axle and motor and an ABB HES 880 Inverter. The front axle is fixed rigidly to the loader's front frame and the drive unit is fixed rigidly to the front axle. **Figure 130** shows a CAD drawing of the electric motor, 1:3 belt drive and front axle of the mining loader.

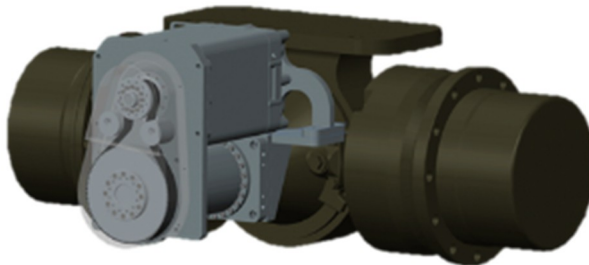

Figure 130. CAD drawing of the electric motor, 1:3 belt drive and front axle of mining loader. Note: belt-driven gearing.

7.5.4 Electromechanical steering

The dimensioning of the electromechanical steering is based on force measurements from the original hydraulic steering cylinder and specified speed values given in the loader's original specifications. The original hydraulic steering was based on one hydraulic cylinder. Due to the unsymmetrical construction, the speed and steering force were variable depending on the steering angle. In addition, the steering speed was different between left and right turns due to asymmetry of volumes inside the cylinder, with the shaft side having a smaller volume than the piston side. Hydraulic steering requires continuous oil pumping to keep the pressure up to maintain immediate steering response. Thus, even if there is no need for steering the hydraulic pump must be running, which continuously wastes several kilowatts of energy. This waste energy is transformed to heat in the hydraulic circuit, which needs to be removed with a separate cooling system, which also wastes energy.

The loader's new electromechanical steering design is heavily over dimensioned so that mechanical strength is sufficient and original performance is easily achieved. The new electromechanical steering mechanism is co-axial with the loader's pivot point axle, which makes the steering function fully symmetric and non-affected by steering angle or turning direction. All movement is rotational between the servomotor axles and steering pivot point. Energy is needed only when there is a need to turn the loader. Efficiency is high and there is no need for active cooling. Controllability is accurate and fast, which offers wide scope for developing steering functions and improving driving feedback. New features can be implemented easily by simply updating the control software. The developed electromechanical steering system is shown in **Figure 131**.

The key component in the electromechanical steering system is the dual input slew drive, IMO WD-H with 1:61 ratio. The slew drive is installed at the pivot point of the loader. The connection between the slew drive and loader is a kind of floating mechanical connection in which the slew drive is connected rigidly only to the front frame of the loader. The loader's rear frame connection is made symmetrically with two reaction rods with ball joints at both ends. The floating connection prevents tilting forces from passing through the slew drive, freeing the slew drive to take care of only the rotational turning torque. The slew drive would be capable of handling quite high tilting forces, but since these forces at the loader's pivot point are unknown it was deemed safer to execute a floating installation in this case. Varying tilting forces can also cause variation in the rotating torque, which would make it difficult to measure the real steering forces and energy consumption of steering, thus the floating connection is preferable also from a research point of view.

The chosen slew drive has two worm gears, which use the same final gear ring. Both slew drive inputs have an additional planetary reduction gear: a Bosch Rexroth gear with 1:20 ratio. A key benefit of the worm gear in the steering application is its self-locking feature, which prevents external forces from causing changes to the steering angle. This also saves energy, because the motors do not need to keep the loader straight when there is no need for steering.

The slew drive has identical servomotors on both inputs and servomotor controllers driving them in sync (servomotors and controllers by Bosch Rexroth). If one motor fails, the remaining motor has enough torque to steer the machine. In such a failure situation, the slew drive's self-locking feature works against the steering, but one worm gear alone is not able to perform locking if the remaining motor is still working. The servomotors have brakes that lock the steering when the machine is parked. The following section introduces the working hydraulics realised with the DDH approach.

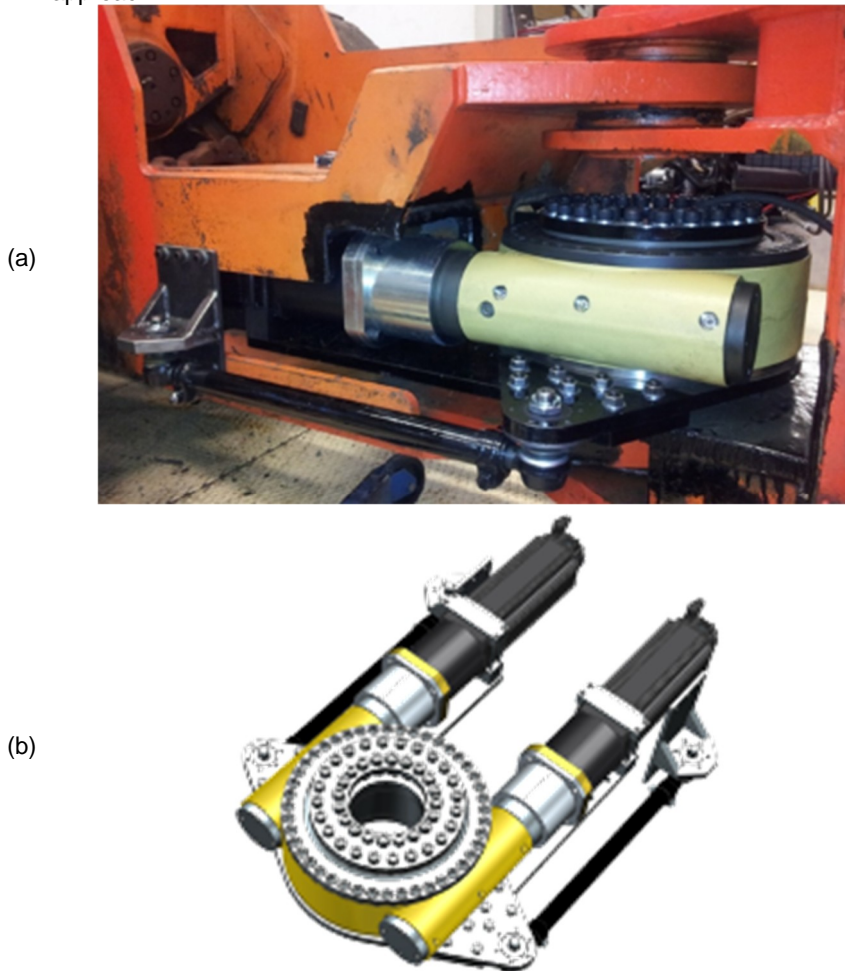

Figure 131. Electromechanical steering: (a) prototype, (b) 3D CAD drawing.

7.5.5 Working hydraulics

In the EL-Zon research project, the mining loader's original working hydraulics was replaced with direct driven hydraulics (DDH). **Figure 132** illustrates the realisation of the DDH. The original working hydraulics ran on its own circuit separate from the drive circuit. The working hydraulic circuit was a typical one-pump system with the diesel engine continually running the pump.

The DDH system is based on the idea that each function has its own pump unit, which is optimally dimensioned for each function's performance requirements^{232,234,235,236}. The loader has two working hydraulic functions; boom up/down and bucket loading/tilting, so two pump units are needed. The pump units differ in pump size and gear ratio, but are otherwise identical.

The DDH drive runs only when the cylinder function is needed, in keeping with the power on demand concept. This saves energy and reduces cooling needs. In addition, dimensioning of the components can be much lighter since the duty hours are only fraction of conventional hydraulics where system is running constantly. For instance, in the loader case both functions are needed only 5–10 seconds each during one work cycle. If the work cycle is about 5 minutes, then the work ratio is about 2-3% of the total work time. High-speed pumps usually have a shorter lifetime, but in the DDH case, this can be ignored since the very low work ratio compensates this.

In DDH dimensioning, the best starting point is when the whole system can be designed and dimensioned from the outset. To achieve an optimised system, the pumps selected for both sides of the cylinder should have the same ratio as the cylinder's two sides in terms of volume. Since custom-made pumps are expensive, it is preferable to choose of-the-shelf pumps from a manufacturer's catalogue and customise the cylinder. Usually the cylinder is customised for the target application anyway, so this presents little difference compared to cylinder dimensioning for a conventional hydraulic system. The only notable difference is the need to fine adjust the ratio to make the cylinder fit optimally with the chosen pumps. Since the pumps will be driven with an electric motor, high-speed hydraulic pumps are ideal as they eliminate the need for a gear between the pump and motor, or at least enable the gear ratio to be as low as possible. The simplest construction can be achieved when the electric motor and the pumps can be coupled axially on the same drive axle. Furthermore, high speed is synonymous with small size in electric motors as well as in hydraulic pumps.

The main challenge presented by the studied mining loader was that it was fitted with original working cylinders dimensioned for the original hydraulic system. Furthermore, the electric motors for both functions had already been procured based

²³⁴ Jarf, A. Flow compensation using hydraulic accumulator in direct driven hydraulic differential cylinder application and effects on energy efficiency, MSc thesis, Aalto, 2016.

²³⁵ Karlen, N. Development of model of direct-driven hydraulics for off-road machinery, MSc thesis, Aalto, 2016.

²³⁶ Minav, T.A., Bonato, C., Sainio, P., Pietola, M. Direct driven hydraulic drive, at IFK, March 2014, Aachen, Germany, 2014.

on known power requirement data. The hydraulic dimensioning was therefore carried out in the following two steps:

Step 1 was to find a suitable pump for both functions. As mentioned above, the correct ratio between the cylinder sides had to be achieved. After several iteration calculations, small, high-speed double pumps were selected to give best possibilities for ratio adjustment. The chosen pump type was an internal gear pump by Hydac. As the ratio between cylinder sides was quite high, two double pumps were used on the cylinder sides, whereas the piston side needed only one double pump. The benefit of this structure is that all pump units are about the same size and thus capable up to about the same speed, which makes easier to fit the electric motor into the system. It would also have been possible to use a one-pump strategy with both cylinder sides having only one pump each, but this would have led to a much bigger and heavier construction, which would have been impossible to retrofit on the mining loader. Another problem with large pumps is the requirement for a high gear ratio between the electric motor and pumps, as big pumps are usually unable to handle high speeds.

Step 2 was to fit the electric motor and all three pump units together and carry out fine tuning for the cylinder ratio adjustment. The solution was to use a double-sided synchronous belt between the electric motors and three pump units. The electric motor speed range is 0-6000 rpm and pump units' speed range about 0-4000 rpm, but the required pump speed also depends on the cylinder speed requirement. Since the ratio adjustment, with pumps only, were not yet optimal, the belt drive gave an additional possibility to get closer to the optimal ratio by selecting suitable size belt wheels.

The achieved no-load accuracy in ratio adjustment was within 1–2%, i.e. very good. It is worth noting that the cylinders were original, thus the cylinder dimensions were not variable, and having the opportunity to choose both pumps and cylinders would have made the dimensioning considerably easier.

Figure 132 shows the DDH drive construction. For safety considerations, a circuit

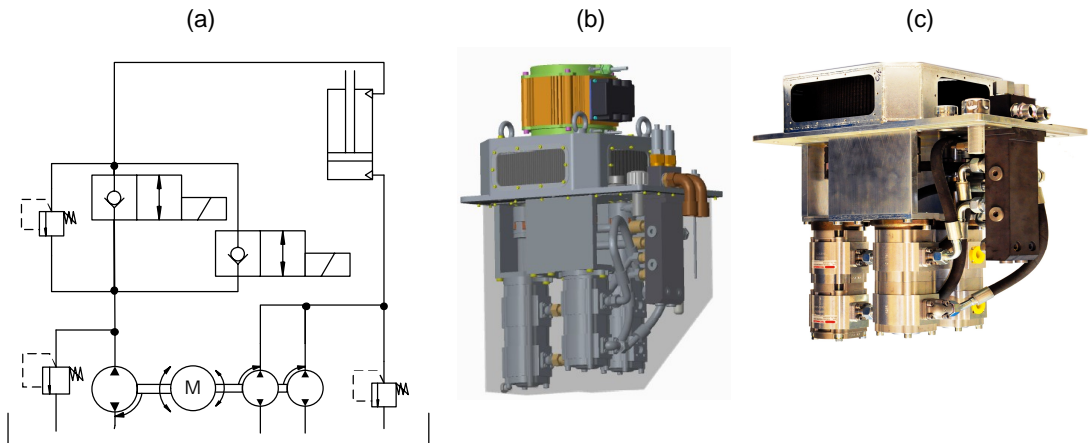

Figure 132. DDH for hybrid mining loader (a) hydraulic schematics, (b) 3D CAD drawing, (c) prototype²³⁷.

layout of the DDH system including valves is presented in **Figure 132a**. All pumps and valves are inside the tank and suction ports are constantly at least 20 cm below oil level. DDH devices are supplied from a 96 V DC-link. The 96 V DC-Link is supplied by a 362 V battery via DC/DC converters capable of up to 3 kW power. Although the required peak power of the DDH devices is around 20–50 kW, the average power needed during the work cycle is below 3 kW.

The DDH electric drives have a Motenergy ME1304 PMSM motor and Sevcon Gen4 size 6 controller. Hydraulic components are by Hydac. Sensors are all equipped with a CANopen interface and are from different suppliers.

7.5.6 Discussion

The following section presents a discussion on the hybrid powertrain, direct driven hydraulics (DDH) and the overall results. The end section contains reflections on potential future application areas in Finnish industry.

7.5.6.1 DDH working hydraulics

DDH as an electrohydraulic actuator reduces parasitic losses for better fuel efficiency and lower operating costs. The robust, leak-free, one-piece housing design delivers system simplicity and lowers both installation and maintenance costs. A challenge is the increasing number of electric components in the limited volume available in the vehicle. On the other hand, the main advantages of this architecture

²³⁷ Minav, T.A., Lehmuspelto, T., Sainio, P., Pietola, M. Series Hybrid Mining Loader with Zonal Hydraulics, IFK 2016, 8–10 March 2016, Dresden, Germany.

are reduced hydraulic tubing, piping and number of potential leakage points, elimination of some hydraulic components, simplified machine assembly, and increased redundancy via motor and controller sensors. Further advantages include decreased demand for cooling of hydraulic oil and amount of hydraulic oil itself on board. Better understanding of how hydraulic oil operates in different work cycle and temperature domains and the implications of this for filtering and service life is, however, needed, although positive opportunities are expected in these areas.

DDH enables the use of hydraulic actuators independently of each other and the provision of hydraulic power to those actuators only when needed. This zonal hydraulics concept will, depending on the work cycle, cut the operating hours of individual circuits²³⁸. Some actuators, for instance in the boom, are used only a few times for a few tens of seconds during work cycles of several minutes. This means the operating time ratio is very favourable in terms of cooling, need of service and maintenance as well as overall durability of components and hydraulic oil²³⁹.

Key findings of the research:

- Electromechanical movement – control is a challenge but outweighed by the benefits.
- Modern belt drives may offer solutions.
- Hydraulics is developing constantly – good engineering is valued here and close monitoring of R&D and industry developments is essential.
- Duty cycle of a work machine / customer is valuable information even though there are many different machines and customers.
- When you need a huge cooler, ask yourself why?

7.5.6.2 Potential future application areas in Finnish industry

While the future of the industry can be difficult to estimate from a university-based research perspective, some key observations were made during the project. These cannot be cross-referenced against the technical literature, but offer valuable points to be weighed and considered.

The Tubridi project engaged in close co-operation with the Forum for Intelligent Machines (FIMA). This network of 40+ Finnish companies provided opportunities to communicate results and a unique opportunity to gain valuable feedback from the industry. This feedback often had a calibrating nature – changes happen, but the steps may be incremental.

Since 2009, i.e. for the entire lifespan of this project, international markets and economies have been in stagnation or even in downturn. This has fostered an inertia and evolution type progress instead of revolution.

Non-road working machines are purchased as investments. Energy consumption and green values have value for certain segments or customers, but productivity

²³⁸ Minav, T.A., Heikkinen, J., Pietola, M. Electric-driven Zonal Hydraulics in Non-Road Mobile Machinery, chapter in the book *New Applications of Electric Drives*, publisher InTech, 2015

²³⁹ Minav, T.A., Papini, L., Pietola, M. A Thermal Analysis of Direct Driven Hydraulics, IFK 2016, 8–10 March 2016, Dresden, Germany, 2016.

and performance are common to all. For novel systems to be compared or even engineered based on the specifications of conventional systems therefore presents a clear challenge. A step in the right direction would be to carefully examine and identify critical aspects affecting performance over the entire work cycle. Information of at least the feeling the machine is operating at top capacity in terms of changing sound of the engine under heavy load, vibrations etc. is important source of information to the driver and it may create “feeling of power”. In electric powertrain the sound landscape may differ significantly. Maintenance brakes and costs also have a significant impact on productivity.

On the one hand, for working machines where the sole objective is to work with a bucket, the role of implements is non-existent. On the other hand, with agricultural and janitorial ‘tractors’ the machine itself is often the power and weight while the work is done with various implements. This simple distinction is central to focussing work cycle reasoning. In the latter case, the electrification of implements is key²⁴⁰ and electrical power take-off will be increasingly needed in the future. Standardisation and common practices are and will continue to be needed because implements are often manufactured by relatively small local companies. Consideration should also be given to whether implements should fit various machine brands.

Electromechanic steering and direct-driven hydraulic and electric drive axles are general segments in working machines in Finnish industry. Different machines have their own application domains and dimensioning practices may vary. Often it seems that there is tradition of over-spec’ing to be ‘on the safe side’. This may be illusion created by customers – they purchase a bigger machine than they need just to be sure of the performance. In this respect, the appearance over the past decade of smaller, even micro-machines on construction sites and farms is of interest. There are more machine power and weight classes to come. Electric powertrains have been used in giant machines, on railways and in large ships. They have even dominated small indoor machines, such as warehouse forklifts. Now the electric powertrain is entering new power classes. It will be very interesting to see what battery and motor voltage levels will become established. It is a relatively safe assumption that there will be low voltage, i.e. around 96 volt, batteries such as those currently serving service personnel and component manufacturers in the forklift business as well as decent size batteries, and that there will be something like a 600 VDC level for bigger power classes. The battery size may include significant dc/dc conversions.

Along with new technologies – mainly in the fields of electrochemical energy storage and power electronics – the amount and role of software will increase. This will breed new types of engineers and a need for ‘integrators’ sufficiently conversant in mechanics, electronics, hydraulics and power electronics as well as software development.

Integration processes are used to define and develop the characteristics of the total vehicle. In contrast to design engineers, integration engineers do not design any particular part, but feed their findings and technical recommendations back to

²⁴⁰ Tammisto, O. Electrification of Agricultural Machines, M.Sc. thesis, Aalto University, 2014.

the component design processes, thus steering the component design. Geometric integration is a major well-established integration process, and terms such as functional integration and systems integration (functional integration of the complete vehicle E/E system: management of requirements, configuration and change management and integration of software with regard to development, production and service) as well as production integration and service integration are already in use in the automotive industry²⁴¹.

Of course, models plucked from the automotive industry are not a ready fit for the Finnish mobile working machine industry. So how do we get components to communicate and work together smoothly and reliably? This challenge of integration proved to be by far one of the most complicated aspects of the project.

7.5.7 Conclusion

This paper contributes to the investigation of hybrid powertrains for non-road mobile machinery and the application of zonal hydraulics using a pilot mining loader first developed under the Tubridi project (2012–2015) and further developed under the EL-Zon project (autumn 2015 onward). The main scientific contribution of the research is the design of a full-scale series-hybrid powertrain and implementation of new design principles aimed at exploiting the benefits of a hybrid powertrain with low traction requirements with a combination of decentralised, e.g. zonal, hydraulics. The degree of hybridisation of the retrofitted series-hybrid powertrain of the mining loader was increased by introducing direct driven hydraulics. Direct driven hydraulics benefit the system by combining the benefits of hydraulics and an electric system, enabling the use of separate hydraulic circuits on demand.

7.5.8 Acknowledgements

This research was enabled by the financial support of Tekes, the Finnish Funding Agency for Technology and Innovation (projects Tubridi and EL-Zon) and by internal funding at the Department of Mechanical Engineering at Aalto University.

²⁴¹ Weber, J., *Automotive Development Process*, Springer 2009.

Appendix A: Publications

All publications that are listed have been done either fully or for the most part in ECV project. ECV was active from 2012 to 2016.

Conference proceedings

1. Hentunen A., Lehmuspelto T., Suomela J., (2012). "Parameterization of electrical battery model for use in dynamic simulations of electric vehicles", Proceedings of the EVS26, Los Angeles, CA, May 2012.
2. Lajunen A., (2012). "Powertrain Design Alternatives for Electric City Bus", IEEE Vehicle Power and Propulsion Conference (VPPC'12), Seoul, Korea, 2012.
3. Lajunen A., (2012). "Development of Energy Management Strategy for Plug-in Hybrid City Bus", IEEE Transportation Electrification Conference and Expo (ITEC'12), Dearborn, MI, USA, 2012.
4. Lajunen A., (2012). "Evaluation of battery requirements for hybrid and electric city buses", Electric Vehicle Symposium (EVS26), Los Angeles, CA, USA, 2012.
5. Lajunen A. and Suomela J., (2012). "Evaluation of Energy Storage System Requirements for Hybrid Mining Loader", IEEE Transactions on Vehicular Technology, 61(8), 3387–3393, Oct. 2012.
6. Montonen J., Montonen J.-H., Immonen P., Murashko K., Ponomarev P., Lindh T., Lindh P., Laurila L., Pyrhonen J., (2012). "Electric drive dimensioning for a hybrid working machine by using virtual prototyping", Electrical Machines (ICEM), 2012 XXth International Conference on Page(s): 921–927, France, Marseille, Sept. 2012.
7. Hentunen A., Kukkonen S., Lehmuspelto T., Pihlatie M., (2013). "Development and validation of a Li-ion battery pack for non-road mobile machinery applications", 27th International Electric Vehicle Symposium & Exhibition, EVS27, 17–20 November 2013, Barcelona, Spain, Proceedings. IEEE (2013), doi:10.1109/EVS.2013.6914805.
8. Lajunen A., (2013). "Development of Energy Management Strategies for Heavy Mobile Machinery", ASME Dynamic Systems and Control Conference, Palo Alto, USA, 2013.
9. Lajunen A., (2013). "Energy-Optimal Velocity Profiles for Electric City Buses", IEEE International Conference on Automation Science and Engineering, Madison, WI, USA, 2013.
10. Bonato C., Minav T., Sainio P., Pietola M., (2014). "Position control of direct driven hydraulic drive", Symposium of FPNI, June 2014, Lappeenranta, Finland.
11. Halmeaho, T., Rahkola, P., Pippuri, J., Tammi, K., (2014). "Hybrid city bus design evaluation using system level simulations", IEEE 23rd International Symposium on Industrial Electronics, ISIE 2014, Istanbul, Turkey, 1–4 June 2014 (2014), 1671–1676. ISBN 978-147992399-1, doi:10.1109/ISIE.2014.6864866.
12. Kukkonen, S., Erkkilä, V., Haavisto, J., Pihlatie, M. (2014). "Energy storage technology requirements for heavy (hybrid) electric commercial vehicles – A promising growing market and durability reference for high-tech batteries", Large Lithium Ion Battery Technology and Application Symposium, LLIBTA 2014, 20–21 May 2014, Kyoto, Japan, Proceedings. Advanced Automotive Batteries (2014).

13. Lajunen A., (2014). "Comparison of Different Powertrain Configurations for Electric City Bus", IEEE Vehicle Power and Propulsion Conference (VPPC'14), Coimbra, Portugal, 2014.
14. Makkonen, H., Tikka, V., Lassila, J., Partanen, J., Silventoinen, P., (2014). "Demonstration of Smart Charging Interface in Green Campus", The 16th European Conference on Power Electronics and Applications, EPE'14-ECCE Europe. Lappeenranta, Aug. 2014.
15. Minav T., Bonato C., Sainio P., Pietola M., (2014). "Direct driven hydraulic drive", IFK, March 2014, Aachen, Germany.
16. Minav T., Murashko K., Pietola M., (2014). "Energy Regeneration and Efficiency in an Electro-Hydraulic Forklift with Lithium-Titanate batteries", IFK, March 2014, Aachen, Germany.
17. Minav T.A., Schimmel T., Pietola M., (2014). "Towards better Energy Regeneration and Efficiency through hydraulic fluid selection in an Electro-Hydraulic Forklift", IFK, March 2014, Aachen, Germany.
18. Minav T.A., Bonato C., Sainio P., Pietola M., (2014). "Efficiency Direct driven hydraulic drive for Non-road mobile working machines", ICEM, September 2014, Berlin, Germany.
19. Minav T.A., Sainio P., Pietola M., (2014). "Direct driven hydraulic drive without conventional tank", ASME/Bath fluid power conference, September 2014, Bath, UK.
20. Nokka J., Laurila L., Pyrhönen J., (2014). "Virtual simulation in energy efficient hybrid powertrain design", The 16th European Conference on Power Electronics and Applications, EPE'14-ECCE Europe. Lappeenranta, Aug. 2014.
21. Pihlatie Mikko, Kukkonen Samu, Halmeaho Teemu, Karvonen Veikko, Nylund Nils-Olof, (2014). "Fully electric city buses – The viable option", IEEE International Electric Vehicle Conference, IEVC 2014, 17–19 December 2014, Florence, Italy. IEEE (2014), 8 p., <http://www.vtt.fi/inf/julkaisut/muut/2014/OA-Fully-Electric.pdf>.
22. Rautiainen A., Järventausta P., (2014). "Load Control System of an EV Charging Station Group", NORDAC 2014 conference, Stockholm, 8-9.9.2014.
23. Tikka, V., Makkonen, H., Lassila, J., Partanen, J., (2014). "Case Study: Smart Charging Plug-In Hybrid Vehicle Test Environment with Vehicle-To-Grid Ability", The 16th European Conference on Power Electronics and Applications, EPE'14-ECCE Europe. Lappeenranta, Aug. 2014.
24. Bin Baharudin, E., Nokka, J., Montonen, J-H., Immonen, P., Rouvinen, A., Laurila, L., Lindh, T., Mikkola, A., Sapanen, J., Pyrhönen, J., (2015). "Simulation Environment for the Real-time Dynamic Analysis of Hybrid Mobile Machines", ASME 2015 International Design Engineering Technical Conferences & Computers and Information in Engineering Conference (IDETC/CIE 2015), Boston, Massachusetts, August 2–5, 2015.
25. Halmeaho, T., Antila, M., Kataja, J., Silvonen, P., Pihlatie, M., (2015). "Advanced driver aid system for energy efficient electric bus operation", 1st International Conference on Vehicle Technology and Intelligent Transport Systems, VEHITS 2015, 20–22 May 2015, Lisbon, Portugal, Proceedings. SciTePress (2015), 59–64, doi:10.5220/0005494600590064.
26. Halmeaho, T., Rahkola, P., Pellikka, A-P., Ruotsalainen, S., Tammi, K., (2015). "Electric City Bus Energy Flow Model and Its Validation by Dynamometer Test", Vehicle

- Power and Propulsion Conference, VPPC 2015, IEEE, 19–22 October 2015, Montreal, QC, Canada: IEEE. Proceedings (2015). ISBN 978-1-4673-7637-2, doi:10.1109/VPPC.2015.7352942.
27. Kukkonen S., Erkkilä V., Manninen A., Haavisto J., Pihlatie M., (2015). "Method for dimensioning battery and thermal management systems for heavy-duty vehicle applications using aged battery experimental data and advanced modelling techniques", ECS Transactions, Vol. 68, Issue 2.
 28. Lajunen A., (2015). "Evaluation of diesel and fuel cell plug-in hybrid city buses", IEEE Vehicle Power and Propulsion Conference (VPPC'15), Montreal, Canada, 2015.
 29. Lajunen A. and Kalttonen A., (2015). "Investigation of Thermal Energy Losses in the Powertrain of an Electric City Bus", IEEE Transportation Electrification Conference and Expo (ITEC'15), Dearborn, MI, USA, 2015.
 30. Laurikko, J., Pihlatie, M., Nylund, N-O., Halmeaho, T., Kukkonen, S., Lehtinen, A-K., Karvonen, V., Mäkinen, R., Ahtiainen, S., (2015). Electric city bus and infrastructure demonstration environment in Espoo, Finland, 28th International Electric Vehicle Exhibition, EVS28 2015, 3–6 May 2015, KINTEXGoyang, South Korea, Proceedings. Korean Society of Automotive Engineers (2015), 11 p.
 31. Minav T., Pietola M., (2015). "Position Control of Direct-Driven Hydraulic Drive without Conventional Oil Tank for More Electric Aircraft", 03 February 2015 - 05 February 2015 Centre des Congrès Pierre Baudis, MEA2015 More Electric Aircraft, Toulouse, France.
 32. Palizban O., Kauhaniemi K., (2015). Power Sharing for Distributed Energy Storage Systems in AC Microgrid: Based on State-of-Charge, IEEE PES Asia-Pacific Power and Energy Engineering Conference (APPEEC 2015), November 2015, Brisbane.
 33. Vilppo O., Markkula J., (2015). Feasibility of electric buses in public transport. EVS28-conference, Korea, May 2015.
 34. Lajunen A. and Tammi K., (2016). "Energy consumption and carbon dioxide emission analysis for electric city buses", EVS29 Symposium, Montréal, Canada, 2016.
 35. Lajunen A., Suomela J., Pippuri J., Tammi K., Lehmuspelto T., and Sainio P., (2016). "Electric and hybrid electric non-road mobile machinery – present situation and future trends", EVS29 Symposium, Montréal, Canada, 2016.
 36. Minav T., Lehmuspelto T., Sainio P., Pietola M., (2016). "Series Hybrid mining loader with zonal hydraulics", 8-10 March 2016, IFK-2016, Dresden, Germany.
 37. Ranta M., Karvonen V., Potter J.J., Pasonen R., Pursiheimo E., Halmeaho T., Ponomarev P., Pihlatie M., (2016). Method Including Power Grid Model and Route Simulation to Aid Planning and Operation of an Electric Bus Fleet, Vehicle Power and Propulsion Conference, VPPC 2016, 17 - 20 October 2016, Hangzhou, China, Proceedings. IEEE (2016), 5 p., doi:10.1109/VPPC.2016.7791724.
 38. Rautiainen A., Markkula J., Järventausta P., (2016). Control of electric vehicles charging in domestic real estates as part of demand response functionality. CIRED workshop, Helsinki, June 2016.
 39. Supponen A., Markkula J., Rautiainen A., Mäkinen A., Järventausta P., Repo S., (2016). Power quality in distribution networks with electric vehicle charging – a research methodology based on field tests and real data. 11th International Conference on Ecological Vehicles and Renewable Energies (EVER2016), April 2016, Monaco.

Journal articles

1. Jalkanen K., Aho T., Vuorilehto K., (2013). "Entropy change effects on the thermal behavior of a LiFePO₄/graphite lithium-ion cell at different states of charge", *Journal of Power Sources*, 254.
2. Liukkonen M., Lajunen A., and Suomela J., (2013). "Feasibility study of fuel cell-hybrid powertrains in non-road mobile machineries", *Journal of Automation in Construction*, 35, 296–305, Nov. 2013.
3. Abdul-Quadir Y., Laurila T., Karppinen J., Jalkanen K., Vuorilehto K., Skogström L., Paulasto-Kröckel M., (2014). "Heat generation in high power prismatic Li-ion battery cell with LiMnNiCoO₂ cathode material", *International Journal of Energy Research*, 38(11).
4. Abdul-Quadir Y., Laurila T., Karppinen J., Paulasto-Kröckel M., (2014). "Thermal simulation of high-power Li-ion battery with LiMn_{1/3}Ni_{1/3}Co_{1/3}O₂ cathode on cell and module levels", *International Journal of Energy Research*, 38(5).
5. Hentunen A., Lehmuspelto T., Suomela J., (2014). "Time-Domain Parameter Extraction Method for Thevenin-Equivalent Circuit Battery Models", *IEEE Transactions on Energy Conversion*, 29(3).
6. Lajunen A., (2014). "Energy consumption and cost-benefit analysis of hybrid and electric city buses", *Journal of Transportation Research, Part C*, 38, 1–15, Jan. 2014.
7. Minav T., Schimmel T., Murashko K., Åman R., Pyrhönen J., and Pietola M., (2014). "Towards better energy efficiency through systems approach in an industrial forklift", *Proc. IMechE, Part D: Journal of Automobile Engineering*.
8. Jalkanen K., Karppinen J., Skogström L., Laurila T., Nisula M., Vuorilehto K., (2015). "Cycle aging of commercial NMC/graphite pouch cells at different temperatures", *Applied Energy*, 154.
9. Jalkanen K., Vuorilehto K., (2015). "Entropy change characteristics of LiMn_{0.67}Fe_{0.33}PO₄ and Li₄Ti₅O₁₂ electrode materials", *Journal of Power Sources*, 273.
10. Liu Z., Wu Q., Christensen L., Rautiainen A., Xue Y., (2015). "Driving pattern analysis of Nordic region based on National Travel Surveys for electric vehicle integration", *Journal of Modern Power Systems and Clean Energy*, doi:10.1007/s40565-015-0127-x, ISSN 2196-5420 (Online).
11. Nokka, J., Montonen, J.-H., Bin Baharudin, E., Immonen, P., Rouvinen, A., Laurila, L., Lindh, T., Mikkola, A., Sopanen, J., Pyrhönen, J., (2015). "Multi-body Simulation based Development Environment for Hybrid Working Machines", *International Review on Modelling and Simulations (IREMOS)*, 8(4).
12. Palizban O., Kauhaniemi K., (2015). "Distributed Cooperative Control of Battery Energy Storage System in AC Microgrid Applications", *Journal of Energy Storage*, 3.
13. Ponomarev P., Minav T., Åman R., Luostarinen L., (2015). "Integrated Electro-Hydraulic Machine with Self –Cooling Possibilities for Non-Road Mobile Machinery", *Strojniški vestnik – Journal of Mechanical Engineering* 61(3), 207–213, doi:10.5545/sv-jme.2014.2017.

14. Halmeaho, T., Rahkola, P., Tammi, K., Pippuri, J., Pellikka, A-P., Manninen, A., Ruotsalainen, S., (2016). "Experimental Validation of Electric Bus Powertrain Model Under City Driving Cycles", The Institution of Engineering and Technology, IET Electrical Systems in Transportation – Early Access (2016), No. September, doi:10.1049/iet-est.2016.0028.
15. Lajunen A. and Lipman T., (2016). "Lifecycle cost assessment and carbon dioxide emissions of diesel, natural gas, hybrid electric, fuel cell hybrid and electric transit buses", *Energy*, 106, 329–342, Jun. 2016.
16. Montonen, J., Nokka, J., Pyrhönen, J., (2016). "Virtual Wheel Loader Simulation – Defining the Performance of Drive-Train Components", *International Review on Modelling and Simulations (IREMOS)*, 9(3), June 2016.

Appendix B: Theses

All theses that are listed have been done either fully or for the most part in ECV project. ECV was active from 2012 to 2016.

Master's theses

1. Antti Alahäivälä, "Sähköautojen lataaminen ja sen vaikutus kaupunkialueen jakelu-
muuntajiin", 2012. AALTO.
2. Tommi Härkönen, "Techno-economical studies for grid impacts of electric vehicle fast
charging", 2012. TUT.
3. Ilkka Kaikkonen, "The hybridization of powertrains in the mobile heavy machinery in-
dustry and changes in industry architecture", 2012. AALTO.
4. Jarno Kukkola, "Verkkosuodattimella varustetun verkkosuuntaajan virtasäätö", 2012.
AALTO.
5. Akseli Mylläri, "High speed electric motor in diesel-electric hybrid mobile machinery"
("Suurnopeuksisen sähkömoottorin käyttö diesel-sähköisessä hybridityökoneessa"),
2012. AALTO.
6. Henri Nieminen, "Sähköauton konvergointi testipenkiksi", 2012. AALTO.
7. Timo Eskelinen, "Maastotyökoneen ajomoottorin hybridisointiin soveltuvan napavaih-
teiston dynamiikan mallinnus", 2013. LUT.
8. Juha Hietikko, "Autojen voimalinjatekniikoiden kehitys - ennuste eri tekniikoiden yleis-
tyimisestä ja niiden vaikutus autoilun kokonaiskustannuksiin", 2013. AALTO.
9. Tuukka Lehtinen, "Electromechanical steering for an articulated mobile work ma-
chine", 2013. AALTO.
10. Joni Markkula, "Sähköautojen latauspalvelut ja latausliiketoiminta", 2013. TUT.
11. Juha Muhli, "Retrofitting electromechanical steering on frame-steered non-road mo-
bile machine", 2013. AALTO.
12. Jarkko Nokka, "Kaivoslastauskoneen hybridisointianalyysi virtuaali- ja in-loop-simu-
loinnin avulla", Diplomityö, 2013. LUT.
13. Ünsal Yurdakul, "Sähköautojen latausverkon yleissuunnittelu", 2013. AALTO.
14. Sampsa Vaurio, "Litiumioniakun oikosulkusuojaus hybridityökoneessa", 2013.
AALTO.
15. Juho Andelmin, "Optimal routing of electric vehicles", 2014. AALTO.
16. C. Bonato, "Position Control and Overall Efficiency of Electro-Hydraulic System",
M.Sc. thesis, 2014. AALTO.
17. Toni Holm, "Litiumioniakuston matalat lämpötilat huomioiva impedanssimalli", 2014.
TUT.
18. Antti Kalttonen, "Ajoneuvon sähköisen voimansiirron lämmönhallinnan mallinnus",
2014. AALTO.
19. Jere Koskinen, "Development of a conversion electric van for delivery business", 2014.
AALTO.
20. Anna-Kaisa Lehtinen, "Sähköbussit osana Turun seudun joukkoliikennejärjestelmää",
2014. TUT.

21. Jan Liljeström, "Electromechanical transmission challenges in non-road mobile machinery drivetrains" ("Sähkömekaanisen voimansiirron haasteet työkoneiden ajo-voimalinjoissa"), 2014. AALTO.
22. Antti Määttä, "Electric vehicle systems - national and user-level perspectives in Northern Europe", 2014. AALTO.
23. Lasse Skogström, "Uusi menetelmä nopeaan tehoelektroniikan luotettavuusarviointiin yhdistetyssä tärinä- ja lämpötilarasituksessa", 2014. AALTO.
24. Otto Tammisto, "Maatalouskoneiden voimansiirtojen sähköistys", 2014. AALTO.
25. Perttu Heikkilä, "Sähköajoneuvoakustojen hallintajärjestelmä", 2015. AALTO.
26. Mika Lötjönen, "Sähköajoneuvojen latauksen ohjaus sähkövoima-järjestelmän vakautusreservinä", Diplomityö, 2015. TUT.
27. Alexander Jarf, "Flow compensation using hydraulic accumulator in direct driven hydraulic differential cylinder application and effects on energy efficiency", M.Sc. thesis, 2016. AALTO.
28. Niko Karlen, "Development of model of direct-driven hydraulics for off-road machinery", M.Sc. thesis, 2016. AALTO.
29. Adore Gasto Lameck, "Integrating electric vehicles into Smart Grid using IEC 61850 and ISO/IEC 15118 standards", M.Sc. thesis, 2016. UVA.
30. Hardeep Rayat, "Using advanced sensors for active control of lithium-ion batteries in mobile machinery", 2016. AALTO.

Licentiate's theses

1. Ari Hentunen, "Electrical modeling of large lithium-ion batteries for use in dynamic simulations of electric vehicles", 2012. AALTO.
2. Matti Liukkonen, "Adopting a multi-stage modeling approach to series-hybrid powertrain design", 2012. AALTO.

Doctoral theses

1. Matti Liukkonen, "Methodologies for development of series-hybrid powertrains to non-road mobile machineries", 2013. AALTO.
2. Antti Lajunen, "Improving the Energy Efficiency and Operating Performance of Heavy Vehicles by Powertrain Electrification", 2014. AALTO.
3. Kirsi Jalkanen, "Electrode material solutions for large scale lithium-ion batteries", 2015. AALTO.
4. Antti Rautiainen, "Aspects of electric vehicles and demand response in electricity grids", 2015. TUT.
5. Ari Hentunen, "Electrical and thermal characterization of large lithium-ion batteries for non-road mobile machinery", 2016. AALTO.

Title	Electric Commercial Vehicles (ECV) Final report
Author(s)	Mikko Pihlatie & Jenni Pippuri-Mäkeläinen (eds.)
Abstract	<p>The report gives an extensive overview of the results of the project entity Electric Commercial Vehicles (ECV) that was active 2012–2016 under EVE programme of the Finnish Funding Agency for Technology and Innovation (Tekes). Contributions to this final report have been made as articles written by several project participants. All the key themes of the project are covered: battery technologies and their applications, electric powertrains and electric vehicles, city buses, non-road mobile machinery, electric commercial vehicle systems and charging, as well as electric vehicles in connection with power grid. Several businesses and products have been launched during the project's span, and continue to emerge and develop in this dynamically progressing field.</p>
ISBN, ISSN, URN	ISBN 978-951-38-8681-3 ISSN-L 2242-1211 ISSN 2242-122X (Online) DOI: 10.32040/2242-122X.2019.T348
Date	March 2019
Language	English, Finnish abstract
Pages	250 p. + app. 7 p.
Name of the project	Electric Commercial Vehicles (ECV)
Commissioned by	Tekes and project partners
Keywords	Electric vehicles, electric buses, batteries, electric motor drives, transport electrification, non-road mobile machinery, charging, TCO
Publisher	VTT Technical Research Centre of Finland Ltd P.O. Box 1000, FI-02044 VTT, Finland, Tel. 020 722 111, https://www.vttresearch.com

Nimeke	Sähköiset hyötyajoneuvot (ECV) Loppuraportti
Tekijä(t)	Mikko Pihlatie & Jenni Pippuri-Mäkeläinen (eds.)
Tiivistelmä	Tähän loppuraporttiin on koottu laaja katsaus projektikokonaisuuden Sähköiset hyötyajoneuvot (ECV) tuloksista. ECV oli vuosina 2012–2016 osa Tekesin ohjelmaa Sähköisten ajoneuvojen järjestelmät (EVE). Raportti on koostettu projektiin osallistuneiden tahojen kirjoittamien artikkelien pohjalta. Kaikkia projektin keskeisiä teemoja käsitellään kattavasti: akkuteknologioita ja näiden sovelluksia, sähköisiä voimalinjoja ja ajoneuvoja, kuten kaupunkibusseja, työkoneita, sähköisiä ajoneuvojärjestelmiä ja latausta, sekä sähköajoneuvoja sähköverkon yhteydessä. Useita liikeyrityksiä ja tuotteita on lanseerattu projektin ajanjakson aikana, ja uusia ratkaisuja kehittyä ja ilmaantuu tällä dynaamisesti etenevällä alalla jatkuvasti.
ISBN, ISSN, URN	ISBN 978-951-38-8681-3 ISSN-L 2242-1211 ISSN 2242-122X (Verkkojulkaisu) DOI: 10.32040/2242-122X.2019.T348
Julkaisuaika	Maaliskuu 2019
Kieli	Englanti, suomenkielinen tiivistelmä
Sivumäärä	250 s. + liitt. 7 s.
Projektin nimi	Electric Commercial Vehicles (ECV)
Rahoittajat	Tekes ja projektin osapuolet
Avainsanat	Sähköajoneuvot, sähköbussit, akut, sähkömoottorikäytöt, liikenteen sähköistys, työkoneet, lataus, TCO
Julkaisija	Teknologian tutkimuskeskus VTT Oy PL 1000, 02044 VTT, puh. 020 722 111, https://vtt.fi

Electric Commercial Vehicles (ECV)

Final report

Transport and mobility are in the middle of a major transition to large-scale electrification of a large range of vehicles, mobility use cases and fleets. Energy efficiency and low emissions are the main benefits of electrical propulsion. With the continuing development of the key technologies, system implementations and new business models, the economic benefits are also emerging fast - first in professional and commercial operation and fleets, later in private mobility. This report summarises main results and findings from a Finnish project entity Electric Commercial Vehicles (ECV). Even though both technology and business in this field are developing rapidly, many of the project's results, produced during 2012–2016, are still surprisingly valid.

ISBN 978-951-38-8681-3
ISSN-L 2242-1211
ISSN 2242-122X (Online)
DOI: 10.32040/2242-122X.2019.T348