

# Architecture Design for NPP Co-Simulation Platform

Poria Divshali | Seppo Hänninen | Pasi Laakso | Timo Korvola

# Architecture Design for NPP Co-Simulation Platform

---

Poria Divshali, Seppo Hänninen, Pasi Laakso & Timo Korvola

VTT Technical research Centre of Finland, Ltd



ISBN 978-951-38-8728-5

VTT Technology 371

ISSN-L 2242-1211

ISSN 2242-122X (Online)

DOI: 10.32040/2242-122X.2020.T371

Copyright © VTT 2020

JULKAISIJA – PUBLISHER

VTT

PL 1000

02044 VTT

Puh. 020 722 111

<https://www.vtt.fi>

VTT

P.O. Box 1000

FI-02044 VTT, Finland

Tel. +358 20 722 111

<https://www.vttresearch.com>

## Preface

---

This work was carried out in the project “COSI - Co-simulation model for safety and security of electric systems in flexible environment of NPP”. The research partners of COSI project are VTT and Aalto University. The work is follow up on request of SAFIR2022, The Finnish Research Programme on Nuclear Power Plant Safety 2019-2022. The work is motivated by the practical and theoretical problems studied in the project “ESSI- Electric systems and safety in Finnish NPP” of the previous SAFIR2018 programme.

The operating model of SAFIR2022 programme consists of a Management Board and four research area steering groups (SG) working under its supervision, as well as reference groups (RG) that are responsible for scientific and technical guidance of the projects. The administration of the programme is conducted by the administrative unit and Programme Director Jari Hämäläinen. COSI project belongs to “SG1 - Plant Safety and system approach to safety” and “RG2 - Plant level analysis”.

A project-specific steering group has also been set up for the COSI project, which will, among other things, direct research and resolve confidential issues related to the project, as the project uses power plant self-generated electrical system simulation models. The project-specific steering group consist of the following members: Seppo Härmälä (Chairman, TVO), Jyrki Kykkänen (TVO), Ari, Kanerva (Vice chairman, Fortum), Juha Eriksson (Fortum), Juha Kemppainen (Fennovoima), Lauri Taivainen (Fennovoima), Monika Adsten (Energiforsk), Per Lamell (Forsmark/Vattenfall), Kim Wahlström (STUK), Samuli Hankivuo (STUK), Liisa Haarla (Fingrid), Minna Laasonen (Fingrid).

Thanks to Seppo Härmälä for reviewing this report as official reviewer appointed by SAFIR 2022 RG2. Thanks also the other member of project-specific steering group for their suggestions to amend the text.

Espoo 28.2.2020  
Authors

**Contents**

---

Preface..... 1

Contents..... 2

List of symbols ..... 3

Introduction ..... 4

Simulation Environments in NPP ..... 4

    1.1 Automation and process model..... 4

    1.2 On-site and Off-site Electrical Model..... 6

    1.3 Importance of Co-simulation Platform ..... 6

Co-simulation Architecture ..... 7

    1.4 Data Exchange layout among simulators..... 7

    1.5 Data Exchange Intervals..... 8

    1.6 Time step handling ..... 8

    1.7 Protocol of data exchange between simulators..... 8

OPC data connection ..... 9

Proof of concept testing..... 10

Conclusions..... 14

Acknowledgements ..... 15

References..... 16

Abstract

## List of symbols

---

ACL	Apros communication library
AVR	Automatic voltage regulator
COSI	Co-simulation
DCOM	Distributed Component Object Model
DLL	Dynamic Link Library
MOC	Model of computation
NPP	Nuclear power plant
OPC	Open Platform Communications
OPC DA	Open Platform Communications Data Access
OPC UA	OPC Unified Architecture

## Introduction

---

One of the main safety principles applied in the nuclear industry is the continuous search for safety enhancements. Analysis of operating experience and lessons learnt - which shall not be limited to plant-specific events - is an important input in this respect. Especially regarding electric systems, disturbances in electric systems both off-site and on-site show that there are good reasons to pay attention to actual robustness of the design of electric systems in nuclear power plants. Not only loss-of-offsite power or loss-of-offsite power combined with emergency diesel generator common cause failure (station blackout) are sufficient scenarios for the design basis. The plurality of relevant disturbances in electric systems is much larger and recent changes both in electric grid circumstances in terms of increased role of renewable power producers, possible increased frequency of extreme weather events and implementation of digital control systems for electric systems mean that the previously thought design basis philosophy for electric systems is not fully valid anymore.

CO-simulation model for safety and security of electric systems in flexible environment of NPP<sup>1</sup> (COSI) project is part of SAFIR2022 programme for Nuclear safety. The project focuses on the electrical system of nuclear power plants and related grid effects. The main focus of the project is to develop a co-simulation platform from nuclear power plant (NPP) process and automation simulation and detailed power system simulation. The purpose of WP1, co-simulation model for NPP, is to develop the on-site and off-site power system model and link thermal and reactor physical models, automation model, and upper power system (out of NPP) models together.

The current simulation tools do not have strong features to simulate all of these parts in details and the development of one simulation tool for the whole chain of NPP including thermomechanical process, on-site and off-site power system model would require huge effort. Therefore, COSI project will exploit the existing models of different subsystems and develop a co-simulation interface for these existing tools. Our plan is to exploit APROS thermal, reactor physical and automation models as there are ready-made models for nuclear power plants and create an interface for co-simulation of Apros with other power system tools, such as MATLAB/Simulink, PSCAD, and PowerFactory.

The work starts by designing the architecture for the co-simulation platform to find the best suitable way for interconnecting the different models in different modelling environments/tools in T1.1, co-simulation architecture design. The architecture design is reported in this deliverable and based on this design the co-simulation platform will be developed in the rest of WP1.

## Simulation Environments in NPP

---

A survey of simulation tools used by NPP owners and Fingrid was done by interviews, at the start of the project. Apros was used in most plants as main process simulation tool for electromechanical equipment. However, for electrical simulation various tools, including Matlab/Simulink, PSCAD PowerFactory, NEPLAN, SIMPOW and PSS/E were mentioned.

### 1.1 Automation and process model

Apros is multifunctional software for full-scale modelling and simulation of dynamic processes like NPP [1]. It has capabilities to simulate e.g. thermal process, nuclear reactor, automation and electric system. It has been used for different kinds of projects e.g. for safety analysis, engineering support, training simulators and simulator assisted automation testing. However,

---

<sup>1</sup> Nuclear Power Plant

the electric system simulation in Apros is simplistic and not made or sufficient for fault simulations in mind. Therefore, an external electric model is to be connected to Apros in this project. Fig. 1 shows a view of Apros user interface.

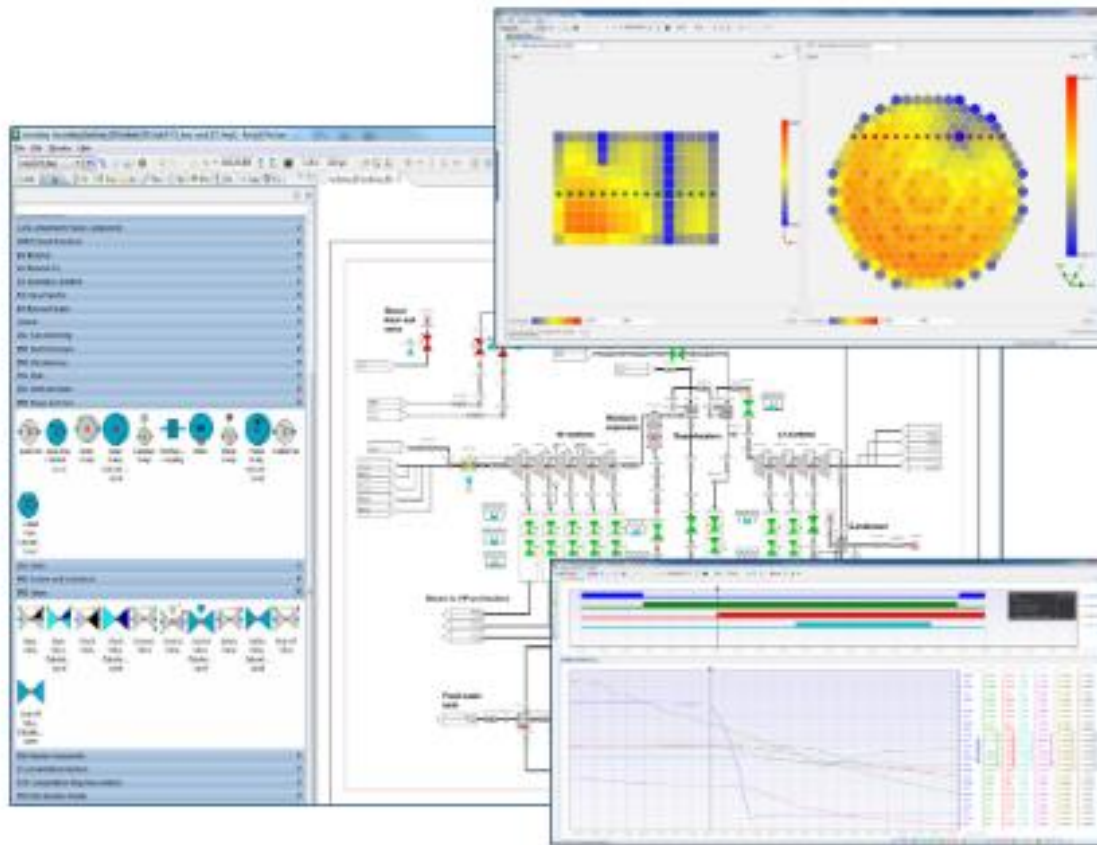

*Figure 1. User Interface of Apros.*

Here are some of the Apros features useful for the purposes of this project:

- Plant model covering reactor island, turbine island, the balance of plant, electrical and automation systems
- Light water reactor types covered: BWR, PWR, VVER
- 1D- and 3D neutronics solvers, incl. two- group nodal kinetic model
- Thermal hydraulic solvers incl. six-equation and three-equation flow models
- Complete process component libraries including containment, cooling towers, passive systems, and severe accident management systems
- Complete automation model incl. PID controls, interlockings, sequence controls
- Plant electrical systems and grid model (not used in COSI project due to limitation to symmetric simulation)
- The graphical user interface for model configuration and simulation
- Connectivity to third-party software (here utilized via OPC)



All in all, Apros has capabilities to model accurately the behaviour of the NPP and interact with external software that augments its solution.

## 1.2 On-site and Off-site Electrical Model

As mentioned in Sub-section 2.1, the ability of Apros to simulate electrical system is limited. Therefore, detailed modelling and simulation of electrical power systems in NPP, including on-site and off-site grids, are performed in separate electrical power system tools, such as PSCAD, PowerFactory, and MATLAB/Simulink. According to the decision of COSI Steering Group, the first implementation of Co-simulation platform will use on-site electrical models from Fortum, which are developed using MATLAB/Simulink. Therefore, MATLAB/ Simulink is briefly introduced in this Sub-section while other power system simulation tools will be explained later when the COSI project implement some electrical models using them. It is important to mention that the co-simulation platform provides the possibility to model on-site electrical grids and off-side power system in different simulators tools.

Simulink is a graphical dynamic simulation package of MATLAB having multiple toolboxes spanning different fields of physics. Power system simulations can be done with Simpower systems package which is hosted under Simscape toolbox. The advantages of using Simulink is a good and stable connection between Simulink and MATLAB. Therefore, the models in Simulink toolbox will be benefited the full computational ability of MATLAB and features of other toolboxes, e.g. control designing.

Although MATLAB Simulink has the ability to model and simulate the thermomechanical process, it is not designed for NPP design and operation, and it is not as powerful as Apros in thermomechanical modelling and simulation. For Instance, the on-site electrical models of NPP use simplified models of Turbines and shafts.

## 1.3 Importance of Co-simulation Platform

In summary, Automation and process model in Apros cannot model and simulate the on-site and off-site power systems of NPP with required details. In the same way, the electrical system models in MATLAB/Simulink or other power system simulators cannot model and simulate the thermomechanical process in details. Therefore, most of the study in NPP neglect the complete interactions of full thermomechanical models and electrical models.

From the technical perspective, this challenge can be overcome using 1) multi-domain simulation environments or 2) co-simulation tools. However, a simulator which supports multi-domain is not trivial to achieve due to the significant effort and expertise required. On the one hand, it is common that the models from different domains would involve different environments and operating systems (i.e. 32 or 64 bit, Windows, Unix or Linux). On the other hand, models from different domains often need to be dealt with using a different time scale, a model of computation (MoC) and specialized solvers. Building a simulator capable of providing appropriate environments, correct MoC, solvers and properly coordinating them internally is expensive and may not be worth the effort [2, 3].

In addition, from the modelling point of view, it is important to integrate commercial and open-source modelling and simulation frameworks, both specialized on particular system aspects (e.g. power system simulator or NPP simulator) and universal (e.g. general modelling environments like MATLAB/Simulink). The specialized tools are usually equipped with validated component libraries, sophisticated import/export capabilities and well-designed user interfaces. In these regards, co-simulation techniques that provide more powerful test environments, using the most suitable simulation tools for all considered domains, from the perspective of accuracy and runtime [4], are required.

## Co-simulation Architecture

In order to assess different systems using co-simulation, it is necessary to integrate the MoC behind a model or a simulator. The MoC represents the interactions between modules, components or phenomena and it is independent of the implementation technology (i.e. sequential or parallel) and language (i.e. Matlab, Python) [4].

The energy domain simulators often employ Dataflow MoC due to the fact that they derive mostly from sets of ordinary differential equations defining the state variables and the environmental factors of a system (e.g. steady-state simulations, electromagnetic transients or circuit simulations). However, ICT, market simulator and eventually control simulators use often the Discrete Event or Finite State Machine MoC.

The discrete models react to events that occur at a given time instant and produce other events either at the same time instant or at some future time instant in chronological execution order. Combining discrete event and continuous simulation requires mixing different MoC such as Discrete Events and Dataflow in a hierarchical way. It leads to the necessity of an interaction semantic that resolves the ambiguities caused by differences among MoC. Events that cross the domains need to be totally ordered and associated with timestamps. Moreover, each domain (simulator and MoC) must also support a rudimentary notion of time. The main difficulties for integration of different MoC involve how to deal with simultaneous events and zero-delay feedback loops.

In these circumstances, the co-simulation architecture design must address the following issues including time step handling, and data exchange layout, interval, and protocol:

### 1.4 Data Exchange layout among simulators.

According to the decision of COSI Steering Group, in the first co-simulation the main generators and all large motors/pump should be simulated in details using a power simulation tool, MATLAB/Simulink for Fortum NPP. In these circumstances, the power system simulators must send the electrical power and rotational speed to Apros and receive the mechanical power from Apros for each large Motor/generators. The initial data exchange layout for this co-simulation is shown in Fig. 2. Later in implementation phase of the project, this layout may be updated.

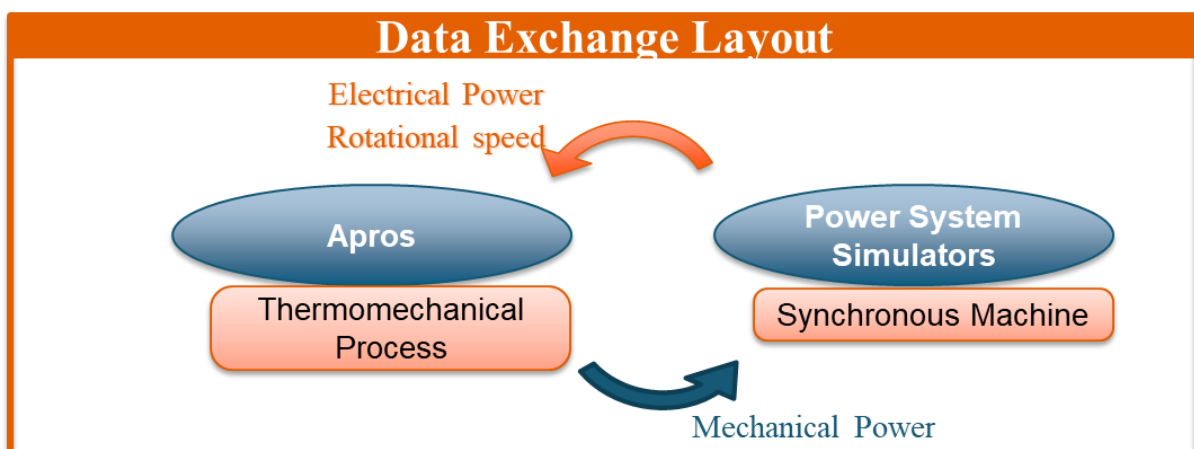

Figure 2. Co-simulation data exchange layout.

## 1.5 Data Exchange Intervals

There are different options for data exchange intervals between two or more simulators [5]. Fig. 3 illustrates different *standard* data exchange options between two simulators A and B. Typically, the parallel data exchanges are faster and allow the different simulators simulate simultaneously. Since the co-simulation of NPP and electrical systems has several connection points and could be slow, running co-simulation using parallel data exchange gives the opportunity of parallel processing. This co-simulation architecture will use parallel data exchange intervals. It means, as explained in Fig. 3, Apros and power system simulator will start from initial condition and exchange the data in each time interval.

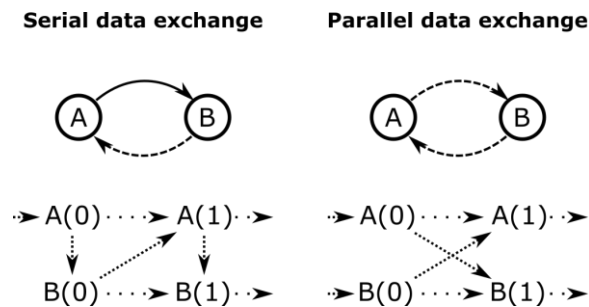

Figure 3. Standard data exchange options between two simulators A and B.

## 1.6 Time step handling

Typically, electrical systems have faster dynamics than an electromechanical system. Therefore, it is wise to select a shorter time step for power system simulators than in Apros. In these circumstances, during one step simulation of Apros, the power system simulators must run for several time steps.

Co-simulation architecture should be paying close attention to this issue. Firstly, each simulator needs to select time steps, small enough to calculate the result precisely. Secondly, the data exchange should happen when all simulators finish their simulation for the related time step. In order to have simpler co-simulation process, this architecture selects the Apros time step as integer factor (let's call  $k$ ) of power system time step. In these circumstances, the co-simulation platform will exchange data between, power system and Apros after 1 run of Apros and  $k$  run of power system simulators. It is important that the platform check all simulators to make sure they finish their task, before data exchange.

## 1.7 Protocol of data exchange between simulators

One of the main challenges in the co-simulation is creating reliable and fast enough channels to exchange data between simulation tools. Each simulation tools has its own method to connect read/write to other programs. Unfortunately, there is no general protocol that all software follow. For example, Apros supports Open Platform Communications (OPC) data connection, while PSCAD does not. The OPC data connection will be explained more in section 4.

Since each simulator has its own methods for simulation, the co-simulation platform needs to have the ability to connect to different simulators using different data connection protocols. For example, OPC for Apros, TCP/IP for PSCAD and so on.

According to the above mentioned issues, the Co-simulation platform architecture consists of a master program, developed e.g. in MATLAB or Python, that can connect with each simulator and send and receive data. Fig. 4 shows the proposed architecture of the co-simulation platform in the COSI project.

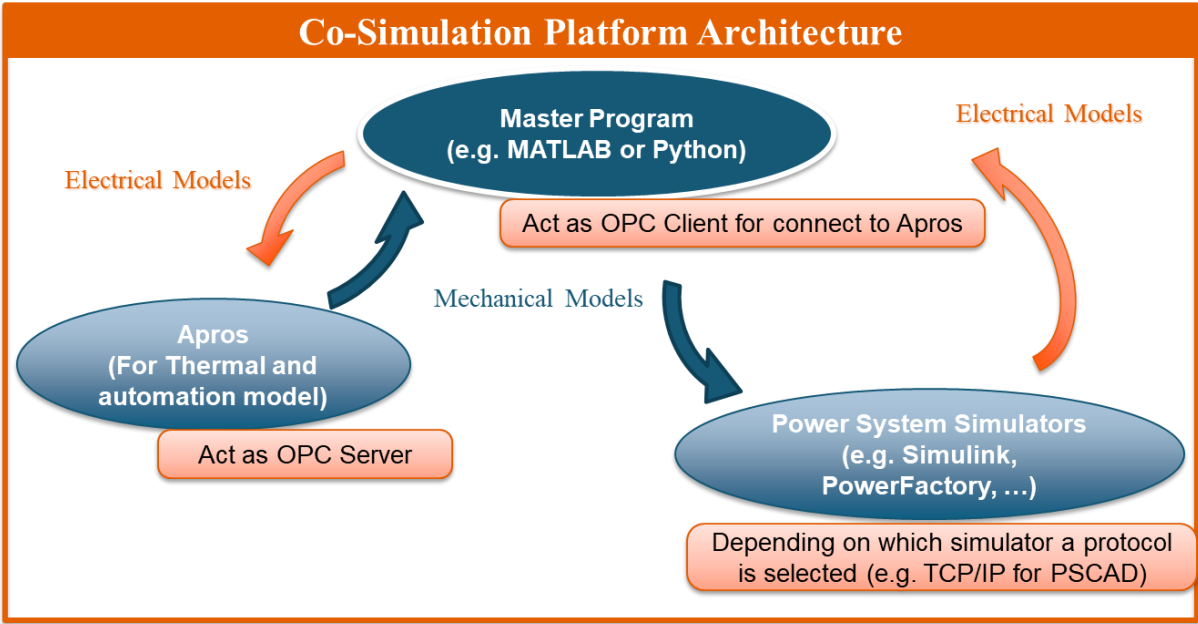

Figure 4. The proposed co-simulation architecture for the COSI project

The platform is based on the OPC standard. Apros has OPC server built-in and OPC client for Matlab is available. The server is started in Apros and then the client can then connect to it and read and write all the variables. Although Matlab Simulink is selected as platform for power system simulator, OPC standard is supported for example in Python which makes COSI platform possible to be connected with other simulators such as PSCAD.

**OPC data connection**

OPC is a set of interface specifications for accessing field devices within control and automation systems i.e. it has been defined from the needs of delivering data from hardware devices to automation systems. Despite its background, OPC can be utilised also for other communication means like communication between simulation tools.

In the project, the OPC DA (Open Platform Communications Data Access, later called only OPC) is utilised, since both Apros and Matlab support it. Apros also supports OPC UA (OPC Unified Architecture), but there were no experiences utilising it with Matlab. OPC DA is an interface based on Microsoft’s DCOM (Distributed Component Object Model) technology and basically provides OPC client functions that can be used to read and write data from the OPC server. Apros has augmented the original interface so that it can be also used to give simulation

control-related commands e.g. simulate predefined time forward and save the state of the simulator. These can be used by Matlab to control the whole simulation system.

The communication can be configured without programming and the whole system is well suited for debugging and prototyping. Both Apros and Matlab user interfaces are visible and useable all the time. Main deficiency is that the used system is quite heavy if you need to be able to run lots of simulation quickly. Another typical problem is the handling of time. In real systems, only real/system time is relevant whereas in the simulated system the simulated time takes similar role and behaves differently, e.g. a simulation could run slower or faster than real-time and time could also jump backwards. Nevertheless, the interface has been found functional in similar connections earlier so this isn't a notable problem in this case.

After the basic concepts have been developed there is a chance to reconsider the interface in different phases of the project. Also, one should consider cases where electrical simulator does not support OPC. In these cases, some other communication means are needed. Apros provides also ACL (Apros communication library) and External model (dll linked to Apros, DLL=Dynamic Link Library) communication interfaces. Both are faster than OPC, but they also change the simulation controller of the whole system. In OPC case simulation controller is Matlab whereas in these other alternatives it is either Apros or some third software that controls both the execution of Apros and Matlab. Utilisation also requires some programming i.e. these interfaces are proprietary and supported only by Apros.

## Proof of concept testing

---

In order to proof testing the co-simulation architecture, a simplified Apros and electrical models have been used to plan the architecture and test the communication in selected cases. These are basis for further development, where full-scale NPP models will be connected to accurate simulators of local and external electrical grid. Typical communication needs of full-scale NPP is similar to this test case, transferring measurements from electrical system to Apros automation that then feeding the control actions back to the electrical stimulator. However, it may require to perform some more complex cases, where communication between generators and motors of the systems need to be updated during the full-scale NPP implementation.

This simplified Apros and electrical models represent a generator connected to a higher voltage power system. The electrical models include a synchronous machine, the automatic voltage regulator (AVR), transformers, and an ideal power system source, which are modelled in MATLAB/Simulink; while the mechanical models of turbine, shaft, valves, and the governor to control the output power of generators are implemented in Apros.

Fig. 5 shows the Simulink model of the test case, where the mechanical power of the generator comes from the Apros simulation. It is important to mention that modelling the power system in MATLAB/Simulink (or other power system simulators) give the ability to model different type of dynamic events, such as single phase fault, which is not possible when using Apros alone. Using this co-simulation model for dynamic study is the aim of this project in later phase and therefore, it will be not discussed further here. Fig. 6 depicts the Apros model, where the electrical power measurement and rotational speed come from the Simulink model.

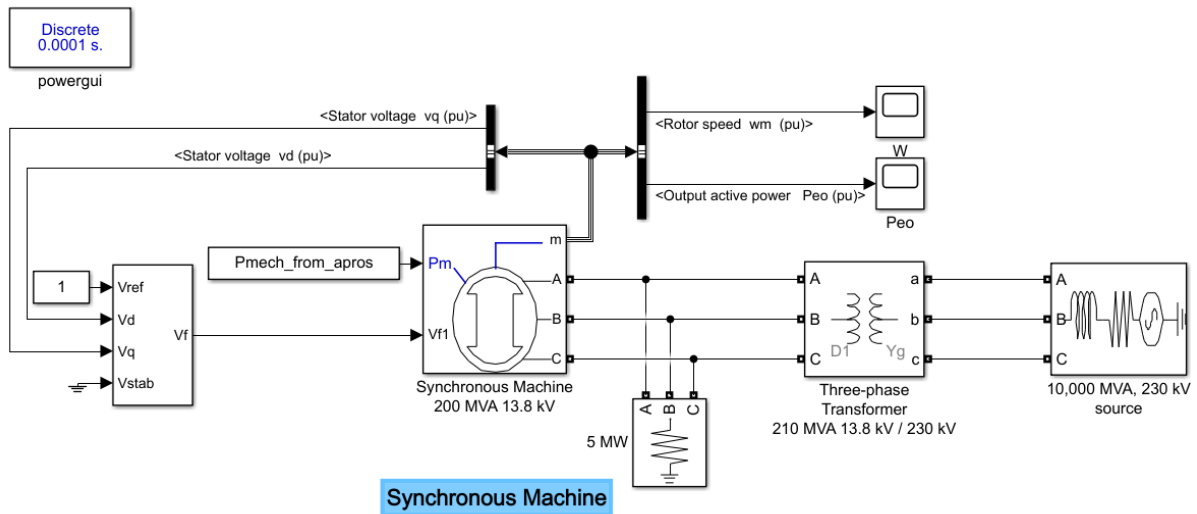

Figure 5. The Simulink model of the test case

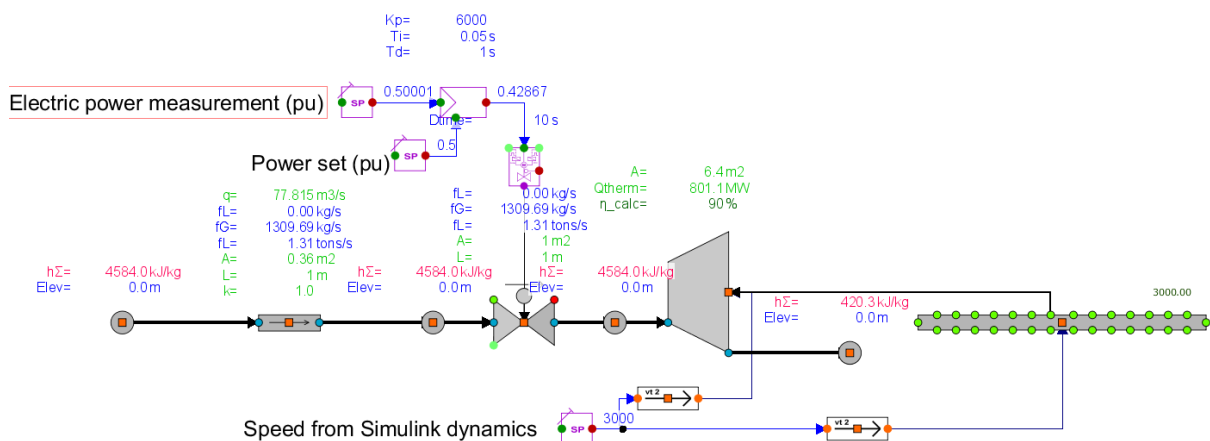

Figure 6. The Apros model of the test case

In order to show that the co-simulation platform is working fine, the setting of the governor controller of the generator, which is implemented by a simple PI control in Apros, is changed from 0.9 pu to 0.5 pu at time  $t = 6$  s in the master program (implemented in Matlab m file). Fig. 7 shows the output and setting power drawn by Apros.

Fig. 7 shows that the Apros controller follows the change in the setting from the master program and output power of the generator model from Simulink. In the same way, the rotational speed coming from Simulink model sets the shaft speed in Apros, as shown in Fig.8.

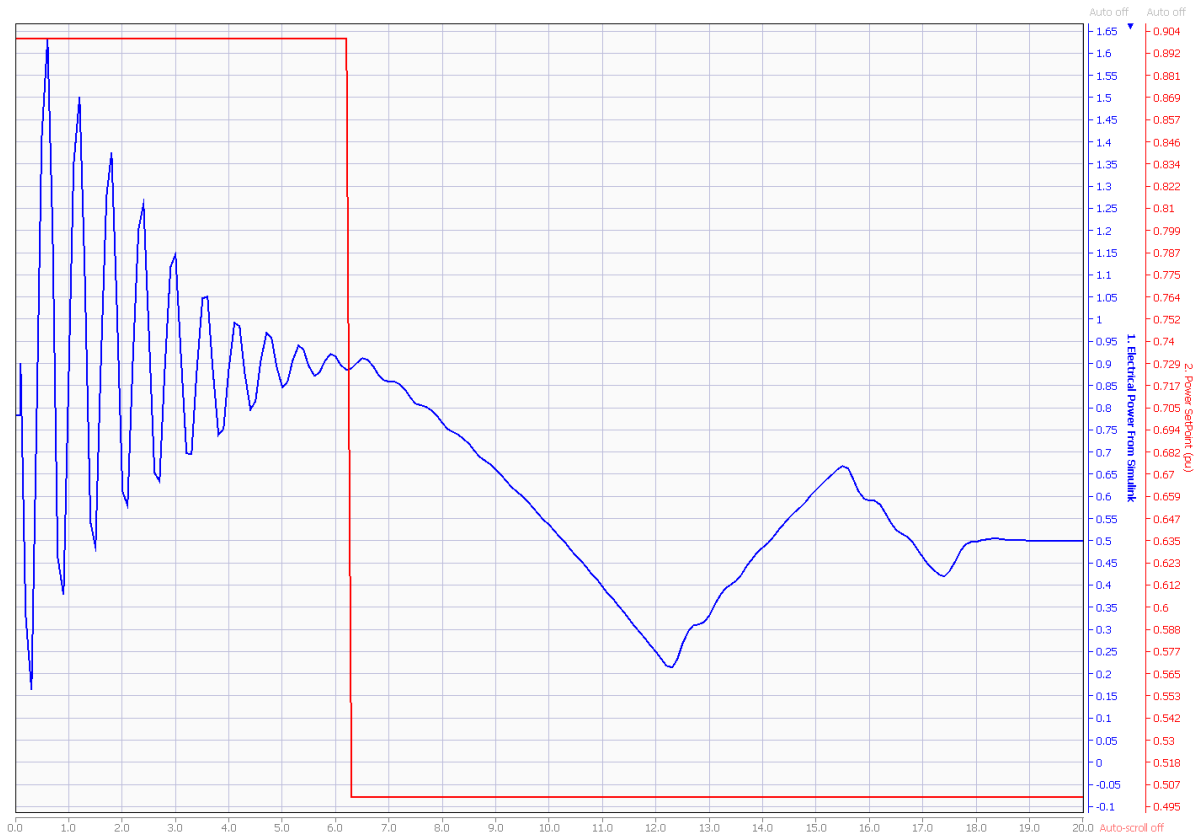

Figure 7. The governor control input ( the output and setting power) drawn by Apros

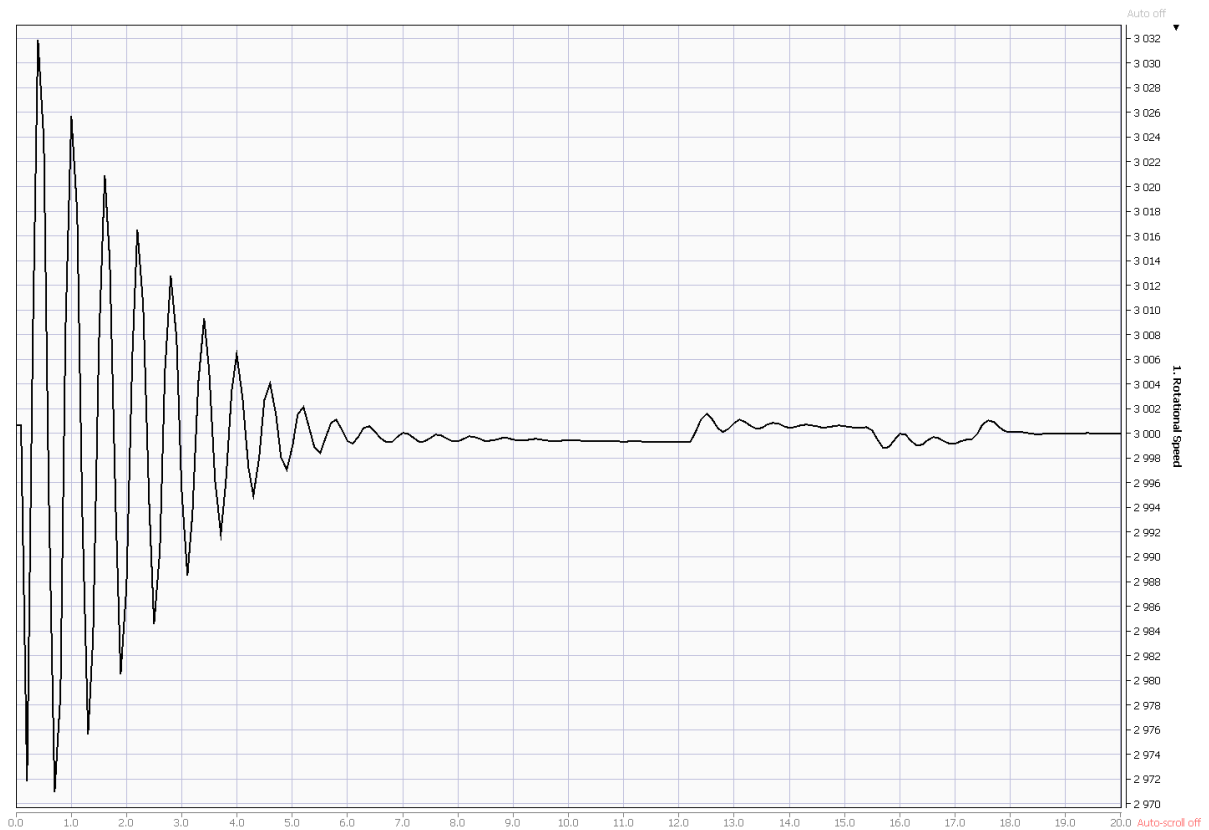

Figure 8. Genrator rotational speed, simulated by Simulink and drawn by Apros

Fig. 9 and 10 depict respectively the mechanical power of the turbine and the mass flow of the valve in Apros.

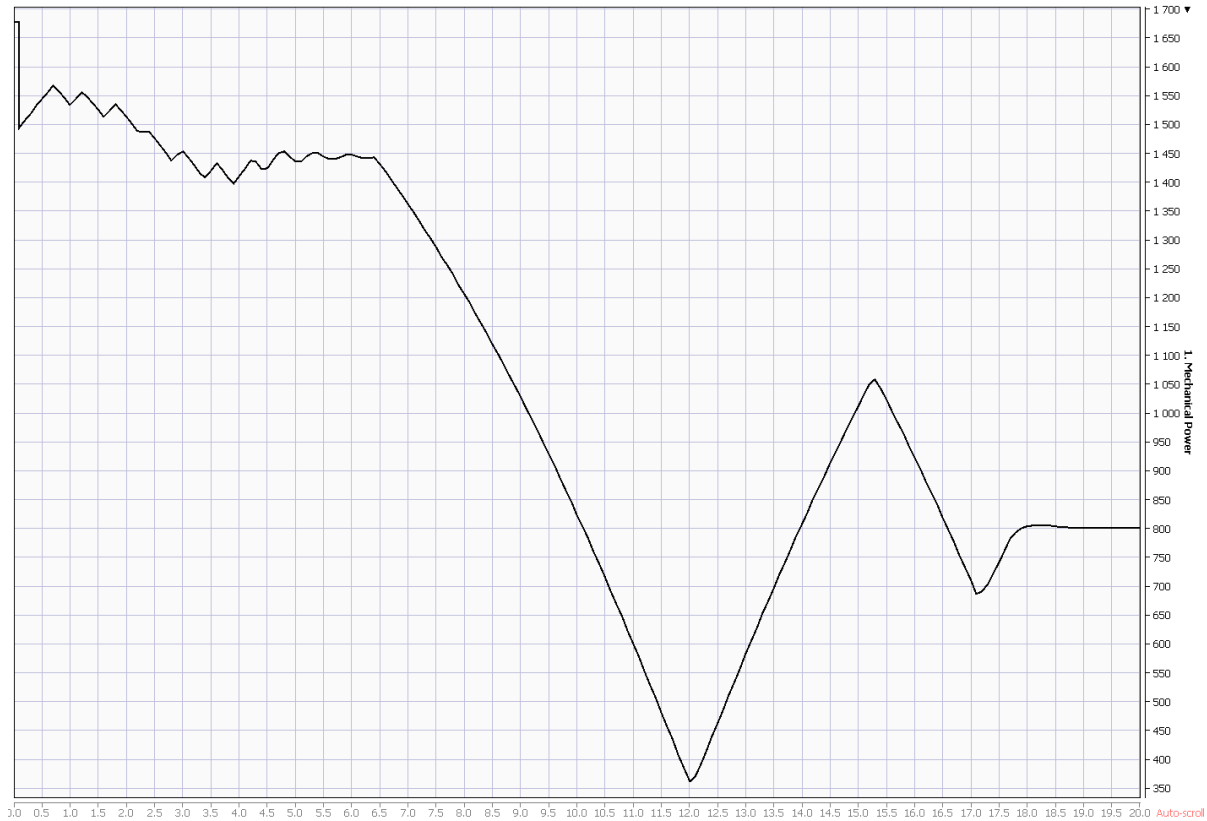

Figure 9. The mechanical power of the turbine in Apros

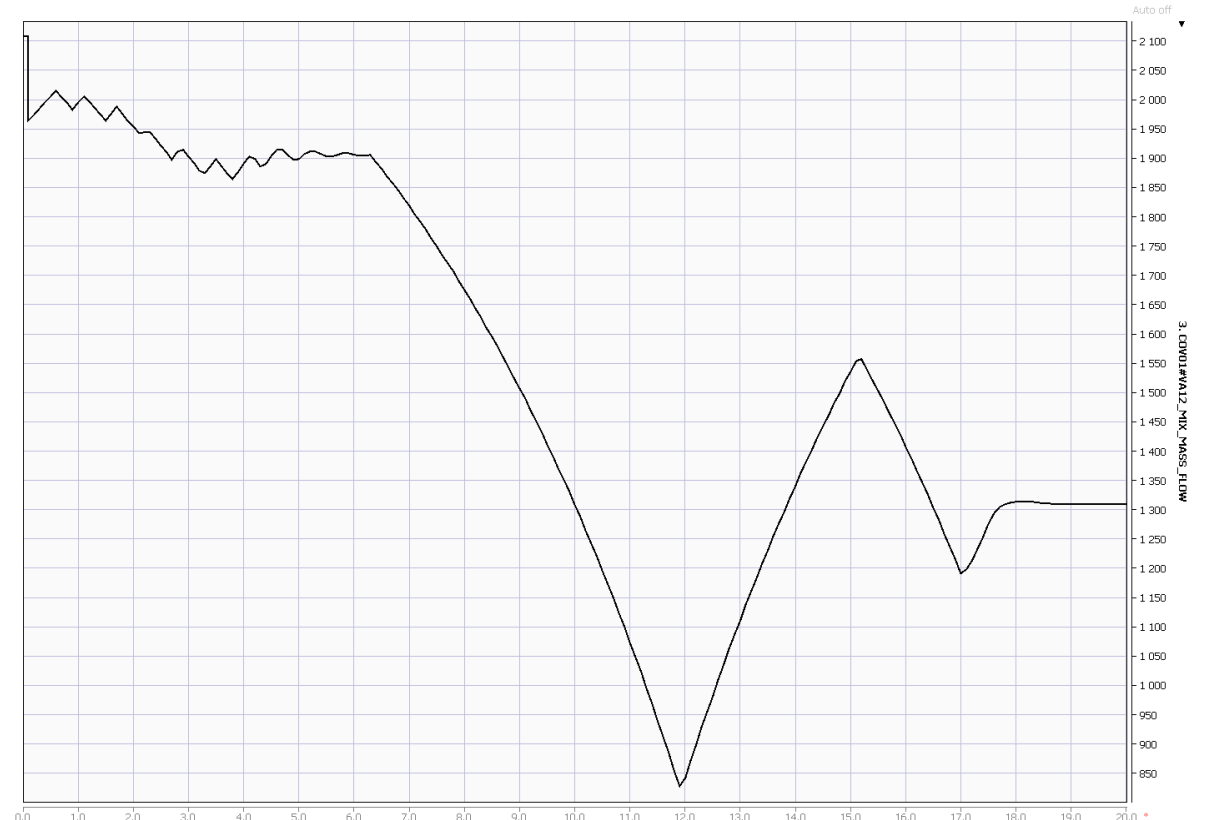

Figure 10. The mass flow of the valve in Apros



It is important to mention that the oscillations in the starting time of the simulation are due to the initial value of different state variables in both MATLAB and Apros. It is possible to set all initial value of two simulators, somehow that these oscillations would not appear, but it is not part of this proof testing and in any case they will be just in the starting of simulation and does not influence in the final results.

Regarding the calculation time in co-simulation, it is not correct to compare the co-simulation time with simulation of one software alone. It is important to notice that the co-simulation will be slower for several reasons, 1) each system modelled and simulated with more details; 2) the co-simulation run simultaneously in two or more commercial software (simulators), where each of them need several overhead calculation, e.g. their userinterface; 3) in each data exchange interval (see section 3.2), the faster simulators waits for the slowest simulators to finish the task.

## Conclusions

---

The initial survey of the project shows that most of the nuclear power plants in Finland use Apros as the main simulation tool for thermomechanical and automation process. However, since Apros cannot simulate the detailed electrical system events, e.g. unsymmetrical faults like one phase fault of the electric system, the detailed electrical power system models are simulated in different simulation tools. In this regard, the aim of this deliverable was to design the architecture of co-simulation platform for nuclear power plant. The co-simulation platform provides the opportunity to simulate interaction between detailed models implemented in different simulation tools.

In this platform, the master program is developing using the Matlab (or Python). Apros will be the OPC server and master program will be the OPC client for connecting to Apros. The master program connects to other power system simulators using appropriate protocol, which depends on the simulator's features. In this architecture, the master program, MATLAB, delivers the mechanical model of APROS to the power system simulators. In the same way, the master program will deliver the electrical model of power system simulators to APROS. The power system simulators can consist of different tools used for simulations like PowerFactory, Simulink, etc.

This deliverable also reports on some of the main challenges of co-simulation in NPP. In order to prove the appropriate working of the architecture, a simplified Apros and electrical models have been developed. The preliminary test results show that the co-simulation and operation of interfaces using simple control commands and different time scales in simulations in normal operation of APROS and Power system simulators works as expected. The real simulations using the exact NPP component models are planned to start in the next year.

## Acknowledgements

---

This work has been mainly funded by VYR – the Finnish Nuclear Waste management Fund. Parts of this work has been funded also by Energiforsk (Sweden), Fingrid Oyj, Aalto University and VTT Ltd. The authors gratefully acknowledge the financial support from VYR, Energiforsk, Fingrid, Aalto University and VTT Ltd.

## References

---

- 1 [www.apros.fi](http://www.apros.fi)
- 2 Johnstone, K., Blair, S.M., Syed, M.H., Emhemed, A., Burt, G.M., Strasser, T.I.: “Co-simulation approach using PowerFactory and MATLAB/Simulink to enable validation of distributed control concepts within future power systems” *CIREN - Open Access Proc. J.*, 2017, **2017**, (1), pp. 2192–2196.
- 3 Latif, A., Shahzad, M., Palensky, P., Gawlik, W.: “An alternate PowerFactory Matlab coupling approach,” in “Proceedings - 2015 International Symposium on Smart Electric Distribution Systems and Technologies, EDST 2015” (2015)
- 4 Strasser, T., Prössl Andrén, F., Lauss, G., *et al.*: “Towards holistic power distribution system validation and testing—an overview and discussion of different possibilities” *Elektrotechnik und Informationstechnik*, 2017.
- 5 Hasanpor Divshali, P., Laukkanen, M., Kulmala, A., *et al.*: “Smart Grid Co-Simulation by Developing an FMI-Compliant Interface for PSCAD” 2019.

Title	<b>Architecture Design for NPP Co-Simulation Platform</b>
Author(s)	Poria Divshali, Seppo Hänninen, Pasi Laakso & Timo Korvola
Abstract	<p>The initial survey of simulation tools in the COSI project shows that most of the nuclear power plants in Finland use Apros as the main simulation tool for thermomechanical and automation processes. However, since Apros cannot simulate the detailed electrical system events, e.g. unsymmetrical faults like one phase fault of the electric system, the detailed electrical power system models are simulated in different simulation tools. In this regard, the aim of this deliverable was to design the architecture of the co-simulation platform for nuclear power plants. The co-simulation platform provides the opportunity to simulate the interaction between detailed models implemented in different simulation tools. The architecture design of the COSI platform bases on using the Matlab (or Python) as the Master program. APROS will be used in Open Platform Communications (OPC) server and Matlab will be the OPC client for connecting APROS, and connecting to other Power system simulators using the appropriate protocol, which depends on the simulator's features. In this architecture, the master program, e.g. MATLAB, delivers the mechanical model of APROS to the power system simulators, and in the same way, the master program will deliver the electrical model of power system simulators to APROS. The power system simulators can consist of different tools used for simulations like PowerFactory, Simulink etc.</p> <p>This deliverable also reports on some of the main challenge of co-simulation in NPP using this kind of design of the architecture. In order to prove the appropriate working of the architecture, a simplified Apros and electrical models have been developed. The preliminary proof results show that the co-simulation, tested with simple control commands and different time scales, works as expected in the normal operation of APROS and Power system simulators. The real simulations using the exact NPP component models are planned to start in the later phase of the project.</p>
ISBN, ISSN, URN	ISBN 978-951-38-8728-5 ISSN-L 2242-1211 ISSN 2242-122X (Online) DOI: 10.32040/2242-122X.2020.T371
Date	February 2020
Language	English, Finnish abstract
Pages	18 p.
Name of the project	Co-simulation model for safety and security of electric systems in flexible environment of NPP
Commissioned by	
Keywords	Architecture design, Automation, Co-simulation, Electric systems, and Nuclear power plants.
Publisher	VTT Technical Research Centre of Finland Ltd P.O. Box 1000, FI-02044 VTT, Finland, Tel. 020 722 111, <a href="https://www.vttresearch.com">https://www.vttresearch.com</a>

Nimeke	<b>Arkkitehtuurisuunnitelma ydinvoimalaitosten yhteissimulointialustalle</b>
Tekijä(t)	Poria Divshali, Seppo Hänninen, Pasi Laakso & Timo Korvola
Tiivistelmä	<p>COSI projektin simulointityökalujen alustava kartoitus osoittaa, että Apros on Suomen ydinvoimaloiden tärkein simulointityökalu, jota käytetään lämpömekaanisten ja automaatioprosessien simuloinnissa. Apros ei pysty kuitenkaan simuloimaan yksityiskohtaisia sähköjärjestelmän tapahtumia kuten epäsymmetrisiä vikoja, esimerkiksi sähköjärjestelmän yksivaiheinen vika. Sähkövoimajärjestelmän tarkkoja malleja simuloidaan muilla simulointityökaluilla. Tämän julkaisun tarkoituksena oli suunnitella ydinvoimalaitosten yhteissimulointialustan arkkitehtuuri. Yhteissimulointialusta mahdollistaa eri simulaatiotyökaluilla tehtyjen yksityiskohtaisen mallien ja niiden vuorovaikutusten simuloinnin. COSI-simulointialustan arkkitehtuurisuunnittelu perustuu Matlabin (tai Pythonin) käyttämiseen isäntäohjelmalla (Master-ohjelma). Apros toimii palvelimella, joka perustuu avoimen järjestelmälustan tiedonsiirtoon (Open Platform Communications, OPC). Matlab on OPC:n asiakasohjelma APROS:n kytkemiseksi ja tiedonsiirtoyhteyden muodostamiseksi muihin sähköjärjestelmän simulaattoreihin sopivan tiedonsiirtoprotokollan avulla, joka riippuu simulaattorin ominaisuuksista. Tässä arkkitehtuurissa isäntäohjelma, esimerkiksi MATLAB, välittää Aprosissa simuloitavan järjestelmän mekaanisen mallin tiedonvaihdon sähköjärjestelmän simulaattoreille. Samalla tavalla isäntäohjelma välittää sähköjärjestelmän simulaattoreiden sähkömallien tiedonvaihdon Aprosille. Sähköjärjestelmän simulaattorit voivat koostua eri työkaluista, kuten PowerFactory, Simulink jne.</p> <p>Tämä julkaisu raportoi myös eräistä ydinvoimaloiden simuloinnin päähaasteista käyttämällä edellä mainittua arkkitehtuurisuunnittelua. Arkkitehtuurin asianmukaisen toiminnan osoittamiseksi on kehitetty yksinkertaistetut Arosin mekaaninen malli ja sähköjärjestelmän sähkömallit. Alustavat testitulokset osoittavat, että yksinkertaisilla ohjauskomennoilla ja erilaisilla aikaskaalauksilla tehdyt simuloinnit toimivat odotetusti Arosin ja sähköjärjestelmien simulaattoreiden normaalissa toiminnassa. Tarkoilla ydinvoimalaitosten komponenttimalleilla tehtävät simuloinnit on suunniteltu aloitettavaksi projektin myöhemmässä vaiheessa.</p>
ISBN, ISSN, URN	ISBN 978-951-38-8728-5 ISSN-L 2242-1211 ISSN 2242-122X (Verkkojulkaisu) DOI: 10.32040/2242-122X.2020.T371
Julkaisu-aika	Helmikuu 2020
Kieli	Englanti, suomenkielinen tiivistelmä
Sivumäärä	18 s.
Projektin nimi	Sähköjärjestelmien yhteissimulointimalli ydinvoiman joustavan käytön turvallisuudelle ja luotettavuudelle
Rahoittajat	
Avainsanat	Arkkitehtuurisuunnitelma, Automaatio, Sähköjärjestelmät, Ydinvoima.
Julkaisija	Teknologian tutkimuskeskus VTT Oy PL 1000, 02044 VTT, puh. 020 722 111, <a href="https://www.vtt.fi/">https://www.vtt.fi/</a>

## Architecture Design for NPP Co-Simulation Platform

The initial survey of simulation tools in the COSI project shows that most of the nuclear power plants in Finland use Apros as the main simulation tool for thermomechanical and automation processes. However, since Apros cannot simulate the detailed electrical system events, e.g. unsymmetrical faults like one phase fault of the electric system, the detailed electrical power system models are simulated in different simulation tools. In this regard, the aim of this deliverable was to design the architecture of the co-simulation platform for nuclear power plants. The co-simulation platform provides the opportunity to simulate interaction between detailed models implemented in different simulation tools. The architecture design of COSI platform bases on using the Matlab (or Python) as the Master program. APROS will be used in Open Platform Communications (OPC) server and Matlab will be the OPC client for connecting APROS, and connecting to other Power system simulators using appropriate protocol, which depends on the simulator's features. In this architecture, the master program, e.g. MATLAB, delivers the mechanical model of APROS to the power system simulators, and in the same way, the master program will deliver the electrical model of power system simulators to APROS. The power system simulators can consist of different tools used for simulations like PowerFactory, Simulink etc. This deliverable also reports on some of the main challenge of co-simulation in NPP using this kind of design of the architecture. In order to prove the appropriate working of the architecture, a simplified Apros and electrical models have been developed. The preliminary proof results show that the co-simulation, tested with simple control commands and different time scales, works as expected in normal operation of APROS and Power system

ISBN 978-951-38-8728-5  
ISSN-L 2242-1211  
ISSN 2242-122X (Online)  
DOI: 10.32040/2242-122X.2020.T371