



Handbook for a Data-Driven Circular Economy in Finland

Data Sources, Tools, and Governance for Circular Design

Tommi Kauppila (ed.)

Handbook for a Data-Driven Circular Economy in Finland

Data Sources, Tools, and Governance for Circular Design

Tommi Kauppila¹ (ed.)

Annukka Berg³, Helena Dahlbo³, Pasi Eilu¹, Pirjo Heikkilä², Ari Hentunen², Katja Hilska-Keinänen³, Susanna Horn³, Hannu Ilvesniemi⁴, Samppa Jenu², Marjaana Karhu², Tiina K.M. Karppinen³, Sari Kauppi³, Päivi Kivikytö-Reponen², Sonja Lavikko¹, Eeva Lehtonen⁴, Sari Luostarinen⁴, Sami Majaniemi², Päivi Malmi³, Mika Naumanen², Jukka-Pekka Ovaska⁵, Liisa Pesonen⁴, Janne Pesu³, Henri Pitkänen³, Jussi Pokki¹, Milja Räisänen³, Jani Salminen³, Svetlana Sapon¹, Eero Siivola³, Jaana Sorvari³, Hannu Tanner², Hannamaija Tuovila², Teuvo Uusitalo², Kristiina Valtanen²

¹GTK Geological Survey of Finland

²VTT Technical Research Centre of Finland Ltd

³SYKE Finnish Environment Institute

⁴Luke Natural Resources Institute Finland

⁵Aalto University



ISBN 978-951-38-8764-3

VTT Technology 401

ISSN-L 2242-1211

ISSN 2242-122X (Online)

DOI: 10.32040/2242-122X.2022.T401

Copyright © VTT 2022

JULKAISIJA – PUBLISHER

VTT

PL 1000

02044 VTT

Puh. 020 722 111

<https://www.vtt.fi>

VTT

P.O. Box 1000

FI-02044 VTT, Finland

Tel. +358 20 722 111

<https://www.vttresearch.com>

Contents

1. Introduction	6
1.1 Data comes with possibilities	7
1.2 Several drivers for a data-based circular economy	8
1.3 Technologies for data-enabled circular solutions	10
1.4 Intended audience.....	12
1.5 Key concepts.....	12
2. Data for a Circular Economy	14
2.1 Materials, value chains, and other sources of data	14
2.2 Food and carbon	15
2.3 Batteries – data through the battery value chain	20
2.4 Textiles.....	21
2.5 Plastics.....	24
2.6 The built environment.....	25
2.7 Primary mineral raw materials and mining waste	26
2.8 Waste	28
2.9 Industrial production and material utilization	29
2.10 Other data sources for circular design approaches.....	29
3. New tools and technologies for data management, distribution, and value addition	30
3.1 Data collection, management, and distribution.....	31
3.1.1 Current state of circular economy data collection, management, and distribution in Finland	32
3.1.2 Data for a circular economy comes from multiple sources.....	34
3.1.3 Case: The FAIR principles of research data as a model for circular economy data management.....	35
3.2 Advanced technologies enable value creation in a circular economy.....	38
3.2.1 Case: IoT can multiply opportunities for value creation in a circular economy	41
3.2.2 Case: Automatic identification methods form the foundation for efficient product and material data collection	41

3.2.3	Case: Blockchain and other distributed ledger technologies (DLT) provide a means for transparency and traceability.....	44
3.3	Methods and frameworks for data analysis, modelling, and decision making in circular design.....	49
3.3.1	Decision-making methods and tools	50
3.3.2	Circular business models and financial decision-making	63
4.	Governance towards a data-driven circular economy.....	71
4.1	Introduction	71
4.2	EU Green Deal paints the big picture for a green transition	74
4.2.1	EU Taxonomy connects financing and the circular economy by 2023.....	76
4.2.2	The new Circular Economy Action Plan guides the transition towards circularity in the EU.....	80
4.2.3	Ecodesign makes products work for sustainability.....	82
4.2.4	Product labelling – from early pioneers to PEF	83
4.2.5	Case: Product passport for batteries – an electronic record to enhance sustainability.....	85
4.2.6	Case: Ownership is reconsidered in a circular economy.....	87
4.2.7	The European Industrial Strategy aims for a more competitive yet sustainable digital Europe	88
4.2.8	Case: Farm to Fork Strategy and the new CAP support the sustainability transition of the food system.....	90
4.3	EU's Digital Decade shows the way towards Europe's digital future	91
4.3.1	The Digital Decade and the Data Strategy are supported by several legal instruments	93
4.3.2	Case: Data altruism.....	95
4.3.3	Common European data spaces.....	96
4.3.4	European Dataspace for Smart Circular Applications	98
4.3.5	Gaia-X and International Data Spaces (IDS): Two prominent European data-sharing initiatives.....	99
4.4	Implementing and developing a data-driven circular economy in Finland	102
4.4.1	Case: Pioneering regulatory framework accelerated MaaS	106
4.4.2	Platform ecosystem for a circular economy connects platforms, marketplaces, and networks	106
4.4.3	Case: Built environment – making the data to serve a circular economy	107
4.5	Conclusions: lessons for future governance efforts to promote a data-driven circular economy in Finland.....	109

Acknowledgements 113

References 114

Appendices

Appendix A. Sources of data for circular design in Finland

Appendix B. Descriptions of the data sources

Abstract

Tiivistelmä

1. Introduction

Design for a circular economy requires data to turn linear material streams and linear products into circular ones and to fully utilize all materials that enter the economy. The concept of circular economy targets closing loops for products and materials, minimizing waste and emissions, and keeping materials in use. The most promising way to turn linear material streams into circular ones is to impact on decisions in the early design phases of products and services, including raw materials production. Designs for a circular economy are useful at all levels of organization and all stages of the value chains, ranging from circular economy-aware designs of physical products to rethinking supply chains or sources of raw materials. Similarly, innovations that strongly promote a circular economy may be found in multiple places along value chains. Common to all of these is the need to see the big picture and to think outside the currently accepted lines of thought.

To achieve these circular economy aspirations, good-quality and up-to-date data is required. Data not only makes it possible to develop circular economy solutions but also helps in identifying opportunities for new ways of doing things and supports evaluation of the feasibility and economic viability of the approaches. In many cases, adding value to data can be the core of a new circular business.

This Handbook has been developed by the Circular Design Network project (CircDNet), a joint undertaking by VTT, GTK, SYKE, Luke, and Aalto University, funded by the Academy of Finland. The mission of the project is to promote data-enabled design-based circular economy solutions, particularly in Finland. As one of the first components of the project, this report reviews data sources that are available for the design of circular solutions in Finland, tools that can be used to manage and extract value from the data, and governance issues that either hinder or promote the adoption of data-based circular design approaches. This information is used to test and demonstrate new circular approaches and opportunities for selected topics by the project. More importantly, however, it can serve as a source of information and inspiration for anyone interested in creating new data-enabled solutions that are circular in design and contribute to a more sustainable future in Finland and beyond.

1.1 Data comes with possibilities

Data is the source of wisdom. In a process of data value creation, data is first processed into information, the information is then combined with other sources, interpreted by human actors to form knowledge, and then enriched further with collective interpretation and experience to form wisdom.

Data-driven approaches are hoped to lead to wisely steered processes in industries and private businesses. Circular design is based on the wise utilization of materials and energy. Situational awareness of customer behaviour, product and service lifetime, system performance, and material flows plays an essential role in developing such solutions (Luoma, Toppinen, & Penttinen, 2021). The significance of data cannot be overemphasized when adopting circular design methods in diverse businesses.

Accessible data is an important enabler of a circular economy. At the heart of a circular economy is circular design, which greatly relies on properly executed data sharing. Data can be put out as fully open or it can be controlled, for example, by a license. Publishing data as open data is an uncomplicated way to make data available and free to use for anyone interested. When data is published as open linked data, the data is machine readable and made available using Internet standards. In this case, an open data source serves as an Internet database and enables automatic linking of data for diverse data processing, such as for circular design processes. Especially public actors, but also private ones are encouraged to publish their data as open linked data.

The free use and utilization of open data creates concerns regarding individuals' and companies' privacy limits. In the era of Industry 4.0 and Internet of Things technologies, the number and quality of data sources has markedly expanded. Most of these data are private, owned by companies or individuals and located in multiple dispersed cloud storages around the world. European strategy (COM-2020-66) on data has paved the way towards a trusted and fair data economy, in which private businesses could also share data and benefit from each other's data in a trusted and safe environment, respecting each other's data sovereignty. This type of controlled data sharing opens possibilities to utilize new data sources to streamline processes in all phases and levels of a product's or service's lifetime. In this respect, the importance of metadata has increased. Depending on the usage situation, knowing, for example, the age, accuracy, or timing of the data may be crucial, but the information also increases the value of the data set as a whole.

Table 1. Uses of data in circular business models. (Luoma, Toppinen, & Penttinen, 2021)

Data category	Definition	Description of a specific use of data in circular business models	References
Customer behaviour	Data on the customer's behaviour, habits, and preferences	The data can yield insight into how customers use various products and services and into how their needs can be met resource-efficiently. The insight enables companies to provide a service rather than a mere product and may help them extend their ownership of the products to the full service life. That, in turn, can encourage optimisation of product's design, maintenance, and lifetime management to support a long service life, ease of reuse, recyclability, and meeting of other circular-economy objectives.	Bressanelli et al., (2018); Khan et al., (2018)
Product and service lifetime	Data on the full service life of a product – raw materials to post-use life	This data type can inform insight into how product life could be extended or how use has affected the reuse value of the component materials. With such insight, companies can extend their product's service life through such means as long-life products, maintenance, and product upgrades. In addition, the most suitable design, operation, and disposal strategies can be chosen in light of the full life cycle, and these choices contribute to reducing consumption or resources.	Khan et al., (2018); Spring and Araujo, (2017); Zheng et al., (2018)
System performance	Data on the operation and performance of systems and value networks – devices, processes, activities, and value chains	This type of data can afford insight into how to improve operations' performance and optimise asset-utilisation, maintenance, and end-of-life activities throughout the systems and the supply chains. Such insight enables optimising systems' resource use by such means as finding and exploiting hidden patterns and correlations or applying data-driven initiation of predictive maintenance actions, thereby averting the risk of subsequent failure and large waste volumes.	Gupta et al., (2018); Lopes de Sousa Jabbour et al., (2018); Tseng et al., (2018); Zhang et al., (2017)
Material flows	Data on flows of materials through various production, consumption, and end-of-life systems	The data can yield insight into the volume, characteristics, and geographical location of various material flows, waste streams among them. This insight can inform efforts to reduce the use of resources and to avoid unnecessary waste streams or build business activities that exploit the relevant streams.	Aid et al., (2017); Mishra et al., (2018); Nascimento et al., (2019); Rajput and Singh, (2019)

1.2 Several drivers for a data-based circular economy

From a governance perspective, there are several drivers towards a data-based circular economy. However, there are also many areas that require action. Figure 1

illustrates that a well-functioning data economy is one that transforms scattered data to knowledge and even systemic understanding. This requires that data is allowed to travel across the value chain and is enhanced to meet the various quality requirements, for example, for traceability. Data collection and exchange also must be well organised. In the field of circular economy, the knowledge generated from the data can spur diverse types of action. It can profoundly encourage the re-thinking of needs, materials, products, and business models, but can also support the extending of product lifespans, for example, with product passports. In general, it can promote the wise use of resources. This has traditionally meant increased recycling of materials but nowadays refers to the minimized intake of materials into the economic system. Furthermore, as cross-cutting measures, all these areas of action could be supported by developing new enabling tools and technologies, by creating networks, partnerships, and ecosystems, and by enhancing various governance efforts.

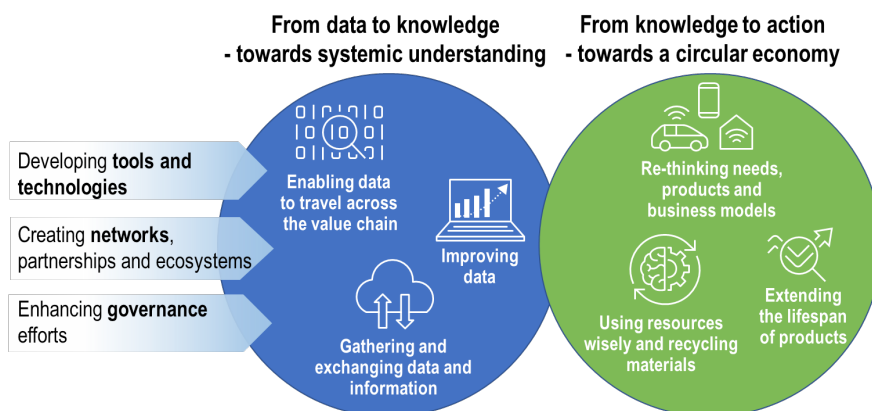

Figure 1. Key areas of action for a data-driven circular economy.

Currently, the EU is proceeding on several fronts to promote a circular economy and digitalization. This twin transition is enhanced by major initiatives such as the Green Deal (COM-2019-640) and its Sustainable Financing Strategy (COM-2018-97), the new Circular Economy Action Plan (COM-2020-98), and the Sustainable Product Policy Framework related to it. At the same time, the EU is seeking to shape its digital future through strategies such as the Digital Strategy (COM-2020-67) and the Data Strategy (COM-2020-66), and legislative initiatives such as the Data Governance Act (COM-2020-767) and the Data Act.

An EU framework for action for a data-driven circular economy has been proposed by the European Policy Centre (European Policy Centre, 2020). Otherwise, the developments towards European governance ideas for a data-driven circular economy have been relatively scarce and scattered outside the EU institutions. This is understandable, as a holistic analysis would soon be outdated due to the many rapid developments taking place. However, there are already

several major development projects that have both data and a circular economy at their heart. These projects include the European Data Space for Smart Circular Applications and some data spaces for Gaia-X.

In Finland, the new strategic programme to promote a circular economy (Valtioneuvosto, 2021) includes a section on digitalisation. It lists three themes as the spearheads for policy development: 1) defining, gathering, and opening the data relevant for a circular economy within a network of key actors and particularly in the public sector; 2) linking various types of data for the benefit of measurement activities and decision-making; and 3) promoting digital circular economy infrastructures both in Finland and abroad.

In this report, we create understanding about the data sources and technologies, and further seek to understand the green–digital twin transition and analyse its bearings for a country such as Finland. Thus, we discuss the key dynamics and the international developments taking place, the national assets, and potential priorities for policy development. These questions are dealt with particularly in Chapter 4 of this report.

1.3 Technologies for data-enabled circular solutions

A lot of data and digitally enabled solutions such as data spaces, digital platforms, smart devices, artificial intelligence, the Internet of Things (IoT), and blockchain are already available and contributing to the circular economy. They are used to improve the use of natural resources and for the design, production, consumption, reuse, repair, remanufacturing, and recycling of products, as well as for waste management. Furthermore, numerous digitally-enabled hardware solutions – digital sensors, mobile phones, connected devices, satellites, and so on – are being used to generate and collect new data, including data for specific purposes such as a circular economy. For this data to be turned into information and added value, it must be managed – that is, collected, systematised, processed, and shared (Hedberg, Šipka, & Bjerkem, 2019). Legislation regarding sustainable production and the circular economy, and the call for transparency are going to require manufacturing companies to meticulously monitor, quantify, and validate the impact of their processes and actions. In practice, this must be done with the help of automated, secure, and trustworthy digital technologies.

In addition to these, creating a fully functioning circular economy in Europe will require new knowledge in several areas such as raw material cycles and the role of producers, designers, manufacturers, consumers, and recycling companies. For these purposes, innovative technologies, such as blockchain and big data analysis, can provide new means for tracing materials and better understanding the socio-economic processes involved. Furthermore, new forms of collaboration and co-creation between different stakeholders will be needed. (European Environment Agency, 2020)

The various visions on how technology together with new business models may shape the world offer even more opportunities for technological innovations. For

example, in the future, at least all valuable assets could be owned by their manufacturer, who will be incentivized to maintain and improve them on an ongoing basis. Cars, computers, washing machines, and fridges could all have the inbuilt ability to communicate with the manufacturer, sending real-time information regarding their usage and the condition of different components, based on which they are maintained, updated, or replaced and recycled, or cascaded into a different use cycle. With a growing number of companies incorporating both IoT-enabled assets and circular economy principles into their strategies and operations, the need for human intervention to maintain, reuse, or recycle materials is already being reduced. This will underline the trust aspect and the importance of validation mechanisms for IoT devices: as data is becoming a valuable commodity, how can the consumer be sure that a device and the values it produces are valid and trustworthy? (Ellen MacArthur Foundation, 2016)

However, it seems likely that the key barriers in moving away from a centralised, optimised, linear economic system and towards a more experimental and decentralised circular economy are not technological. In fact, not a single technological barrier is ranked among the most pressing circular economy barriers (Kirchherr, et al., 2018). Factors such as consumer behaviour, industrial ecosystems, infrastructure, financing schemes and policies have evolved in parallel over decades, based on decisions and efficiency improvements that reflect a linear logic. These system elements are closely intertwined and aligned with each other, creating strong lock-ins. (European Environment Agency, 2020)

While data and digitally enabled solutions can be used to create new, sustainable services and business models, change thinking and processes, and even disrupt current practices, this is not without problems. If not properly guided and governed, there is a risk that digitalisation will result in unwanted side effects. The energy and raw materials required for digitalisation as well as the electrical and electronic waste that may result from the transformation also raise sustainability challenges. The need to track components and products throughout their life cycles will inevitably create concerns about the implications for data privacy and security. Innovations are needed to ensure that sacrificing our privacy is not the price we have to pay to achieve a sustainable economic model. (Hedberg & Šipka, 2020)

The systemic change that is required to transfer to a circular economy will not be enabled by technological advancements alone, as economic and social aspects also play a vital role. The basic principles that the linear economy has been built on need to be challenged. For example, who owns raw materials and are the owners responsible for keeping the raw materials and materials in the economic value cycle? What is the role of consumers? Will there be a wider change, from ownership to the use of products and services? These questions illustrate the range of issues for which new data and knowledge are needed. (European Environment Agency, 2020)

1.4 Intended audience

This Handbook has been developed by Work Package 2 of the Circular Design Network project, designed to map data and tools for design-based circular solutions. It therefore reviews data sources that are available for the design of circular solutions in Finland, tools that can be used to manage and extract value from the data, and governance issues that either hinder or promote the adoption of data-based circular design approaches.

The new circular economy solutions that may arise from innovative thinking, new methods, and clever use of data must both promote sustainability and be economically viable. The handbook is therefore intended for people and organizations that want to develop such new, design and data-based circular solutions. These could be based on new products or materials that utilize circular raw materials, new circular business models, or new services. Knowledge of available data sources can open opportunities for developers and innovative minds and generate new business ideas that create value using circular economy data.

The handbook is also intended for authorities whose decisions can influence the success of the circular economy, either through the removal of obstacles or promotion of circular practices. These organizations include those that are responsible for regulatory activities that affect the circular economy and organizations whose aim is to promote circular business in a specific industrial sector or geographic region.

Finally, the handbook can be utilized by those interested in the data behind the new circular solutions, be they owners of data or those developing solutions for working with data. In this third category, the owners of data often find that their data are underutilized in the circular economy context, providing untapped potential for better environmental performance or new business, while organizations specialized in managing and extracting insights from data can identify data business opportunities in a data-based circular economy.

1.5 Key concepts

Circular Economy. Circular economy is a technical and economic model that aims at eliminating waste and pollution, reducing the consumption of materials and energy, keeping products and materials in use, and regenerating natural systems in a way that is environmentally, socially, economically, and energetically sustainable.

Data. Data refers to (often numeric) information about some specific thing or phenomenon. Data differs from information, although the terms are often used interchangeably, and data needs to be filtered or otherwise processed for it to become information. In the context of a circular economy, different examples of data include information about materials (e.g., their locations, amounts, qualities) and processes (how fast or costly a certain process is).

Data altruism. Data altruism refers to sharing of data voluntarily and freely for the common good. Within the EU, data altruism is seen as an asset to increase Europe's success against a global competition. Having large amounts of data is an essential part of developing machine learning. Thus, big data and data pools with high quality, re-usable data may pave the way to new innovations and solutions.

Producer ownership models. In producer ownership models, the ownership remains with the producer instead of the user (who could be business or consumer). In practice, these models can mean providing a product, material, or performance as a service. In addition, function guarantees, such as extended warranties and deposit systems, can also be considered producer ownership models. From the circular economy perspective, a key aspect is that as the ownership remains with the producer, which encourages a more circular design.

Product labels. Designers and manufacturers are guided towards sustainability and the circular economy with authorized labels and badges. These product labels are also used in communication and marketing of the products, to help consumers in choosing more environmentally friendly products and services. Examples of product labels include the EU Ecolabel and the Nordic Swan Ecolabel.

Product passports. A digital solution that promotes the sustainability of products through the information that accompanies them. In EU strategies, such a passport is outlined to include information on a product's origin, durability, composition, reuse, repair, and dismantling possibilities. A pioneering example of a product passport is the GBA Battery Passport. This will be a sustainability certificate that contains all applicable information on environment, social, governance, and life-cycle requirements involving all actors in the battery value chain.

Twin transition. Twin transition refers to the simultaneous transformation to both more sustainable and digital modes of operation. The idea is that these transitions can have synergies and influence the uptake and speed of each other. Seeking to utilise data to promote a circular economy is a primary example of a possible twin transition.

Systems thinking. Systems thinking is a way of looking at the world and a methodological approach to understanding parts, wholes, and their interactions. Instead of analysis, systems thinking focuses on synthesis, i.e., observing how different parts of a system interact to form the whole. Systems thinking helps understand how different systems work and interact over time, and one of its key features is the ability to represent and assess dynamic complexity.

Open data. Open data can be found and made available on the Internet in its entirety and free of charge in a usable and editable (i.e., machine-readable) format. Open data is freely viewable, downloadable, copyable, editable, distributable, and usable by anyone in any lawful activity without economic, legal, technical, social, or practical restrictions. The terms and conditions of use and licenses of open data guarantee the data producer the right to be properly named and the user to be sure of the origin of the data. There are no other conditions restricting use. (Digital and Population Data Services Agency, 2021)

2. Data for a Circular Economy

2.1 Materials, value chains, and other sources of data

As discussed in the previous chapter, data provides many opportunities for new innovations and approaches in the circular economy. In addition, several high-level governance drivers and global trends (see Chapter 4) work in a direction that will increase the need for data as a basis for new, systemically designed solutions that are inherently circular. At the same time, we have a wide array of new powerful digital tools available to analyse and extract value from data for circular design outcomes (see Chapter 3).

This chapter presents sources of publicly available data on selected materials and material flows in Finland. It also reviews other sources of data that can be of use when designing viable new circular solutions that utilize data. The sections below introduce sources of data that are available for various sectors in Finland, while individual data sources are described in more detail in [Appendix A](#). The aim is to help the readers of this report to locate the data and learn how these data sources can be accessed, what are the conditions for their use, what exactly is available, and what are the limitations of the data sets. In addition to materials and their flows through the value chains, additional sources of data are reviewed that can help in developing design-based circular solutions or data business in the circular economy realm. These include data such as geographic information on the circular economy, circular business data, general waste statistics, and statistics on industrial production, outputs, and expenditures.

This report is part of the Circular Design Network project, which selected three topics as test cases for the development of novel data-driven circular design concepts. These topics include Food and Carbon, Batteries, and Textiles. Data sources for these value chains are studied against their system diagrams, i.e., flows of materials between the various components of the value chains. Such analyses allow the identification of flows within the systems that currently lack data sources or where these sources are not easily available to boost innovation and systemic design.

Besides the three main topics selected, data sources for other materials and value chains were addressed according to their availability. The other data sources include plastics, waste electronic and electrical equipment, the built environment, primary mineral sources and mineral wastes, and water. These sectors can provide materials for circular solutions on their own or combined with materials included in the CircDNet main value chain material flows. Additionally, chemical knowledge is an important part of a safe circular economy, and the legal obligations include a large number of actors. Therefore, the essential data sources, addressing chemicals, are discussed accordingly.

2.2 Food and carbon

Eeva Lehtonen, Sari Luostarinen, Hannu Ilvesniemi

The global CO₂ balance in the atmosphere is dependent on the balance between carbon inputs and outputs to the atmosphere. Emissions from fossil fuels are the major driver in increasing atmospheric carbon, but biomass production and land use also have significant effects. Globally, it is estimated that food production is responsible for one-fifth or up to one-third of the world's greenhouse gas emissions (IPCC, 2019) (Poore & Nemecek, 2018).

The food system includes food production on farms and post-farm processes such as food manufacture and food distribution. Side streams and their proper management play an important role in the carbon cycle of the food system, as carbon can be restored to soil in the form of plant residues, manure, and recycled fertilizer products. The food system with its material chains is presented in Figure 2. The focus is on the carbon cycle of solid and liquid materials.

Global anthropogenic land use changes include afforestation, deforestation, reforestation, and urbanization. Carbon cycles in agriculture and forestry can be analysed using several tools developed in various EU countries.

Climate, land use, management practices, and edaphic factors affect the amount of carbon stocks, but changes in these pools are not well understood. Greenhouse gas emissions, carbon stocks, and changes in stocks are complex to measure, complicating the verification practices.

Net primary production and decomposition rates vary naturally between sites, but certain management practices are also known to have positive effects on the size of the carbon stocks in forests and cultivated soils. In arable land, management practices and history affect the accumulation of carbon. Globally applied conservation principles include minimizing soil disturbance, maximizing surface cover, and stimulating biological activity through cover crops, crop rotation, and integrated nutrient and pest management.

The Biomass Atlas gives detailed information on agricultural and forest products and side streams (Lehtonen, et al., in preparation). This annually accumulating information makes it possible to analyse the effects of existing or planned new products or production methods on many aspects of the circular economy, such as logistics, carbon emissions, and stocks. Awareness of the availability of detailed statistical data facilitates the development of new solutions.

The material budgets of the whole production chain of plant and animal-based products can be calculated using the mass and concentration of a selected biomass. When the circulation of food carbon is estimated, the whole production chain needs to be analysed, including soil preparation, fertilization, irrigation, pest treatments, harvest, yield preparation, transport, industrial processing, transportation, food use, waste management, and reuse of nutrients.

Several types of methods to be used in carbon markets are under development. These products need to be able to quantify the sold carbon units and estimate the stability of the carbon added, as well as the economic and social acceptability of

such operations. Good basic understanding of the processes and amounts related to carbon accumulation are essential parts of such markets.

The food chain spans from primary production through food manufacturing and processing to consumers (Figure 2). We cannot circulate food in a same way as we can circulate some other items such as clothes or batteries. Therefore, material efficiency is emphasized when talking about a circular economy of food: In all stages of the food chain, various types of side streams exist. There is a need to develop these side streams into products and minimize the losses, because significant amounts of carbon and nutrients are taken into the food chain as well as emitted from it. Recycling or prolonging the circulation of carbon and nutrients would minimize the use of non-renewable inputs to the food chain and diminish waste.

The food chain includes actors of different sizes: farms, manufacturing, retail, and consumers. New actors have joined or should join the chain to utilize the side stream biomasses and turn them into new products. Recycled fertilizers are especially important to enhance the resource efficiency and self-sufficiency of the food chain. Recycled fertilizers can contain organic matter or nutrients such as nitrogen and phosphorus. Organic matter maintains the fertility of soil and its ability to retain moisture, whereas nutrients are needed for plant growth.

Data related to carbon and nutrient cycles of the food chain is described based on systemic description of the food chain (Figure 2). Key data sources are listed in Table 2.

Abundant statistical data is openly available on agricultural production at the national level ([Appendix A](#), 1.1.–1.4., 1.6., 1.7., 1.8. and 1.10.). In many cases, regional data is also available. The data is open or at least numeric and public. Natural Resources Institute Finland (Luke) is an official statistical authority and provides statistics on crops (1.1), livestock (1.6.), and food production (1.2.; 1.7.). The Biomass Atlas (1.15.) compiles data on production and side streams spatially at an even more accurate level (Natural Resources Institute Finland (Luke), 2021). Both the theoretical and technically available amounts of side streams are reported. There are various ways to utilize side streams, but location-specific or even national rates of utilization are poorly known. Therefore, the volumes of side streams available for new types of utilization can only be estimated.

There are numerous data sources for crop and animal-based products (1.2.; 1.7.), but the data is scattered among various reports published by different organizations. National statistics on the main product types are openly available, but more detailed information on different sectors of food production needs to be collected from branch-specific reports or annual reports of companies.

Data on fertilizers (1.3.) used in agriculture is scattered in many sources and it is only partly public. A significant part of the data is not even available for research.

Due to the data collection work carried out by Luke and the Finnish Environment Institute (SYKE) since 2010, manure data in the Finnish context is more comprehensive than for many other organic biomasses and better than in many other countries (1.8.).

Major producers of slaughter waste (1.9.), biowaste (1.11.), and sewage sludge (1.12.) report their waste data to the YLVA monitoring system of environmental

permits (9). The generation of this type of waste is not known for small companies, and the total amounts are also estimations based on the population and studies on waste formation per capita. More information is needed about the processing of wastes and side streams of animal and plant origin. A recent study analysed the amount of food waste in the whole food chain of production and consumption, and there are plans to make regular updates for the food waste data (1.10.).

Circularity is a comparably new paradigm in the economy, and the majority of the data used to evaluate and design the circular economy was originally collected for some other purpose, such as to follow the sectoral economic performance in a more traditional way. Data on materials and biomasses exists and is available at some level.

In this report, we focus on publicly collected data. Many private operators such as companies and associations also collect data on their industry. Advanced technologies for data collection and management are used. Farmers are obliged to record accurate field-specific data as part of EU agricultural subsidies, but the data is not collected and made public as a whole and thus not available even for researchers.

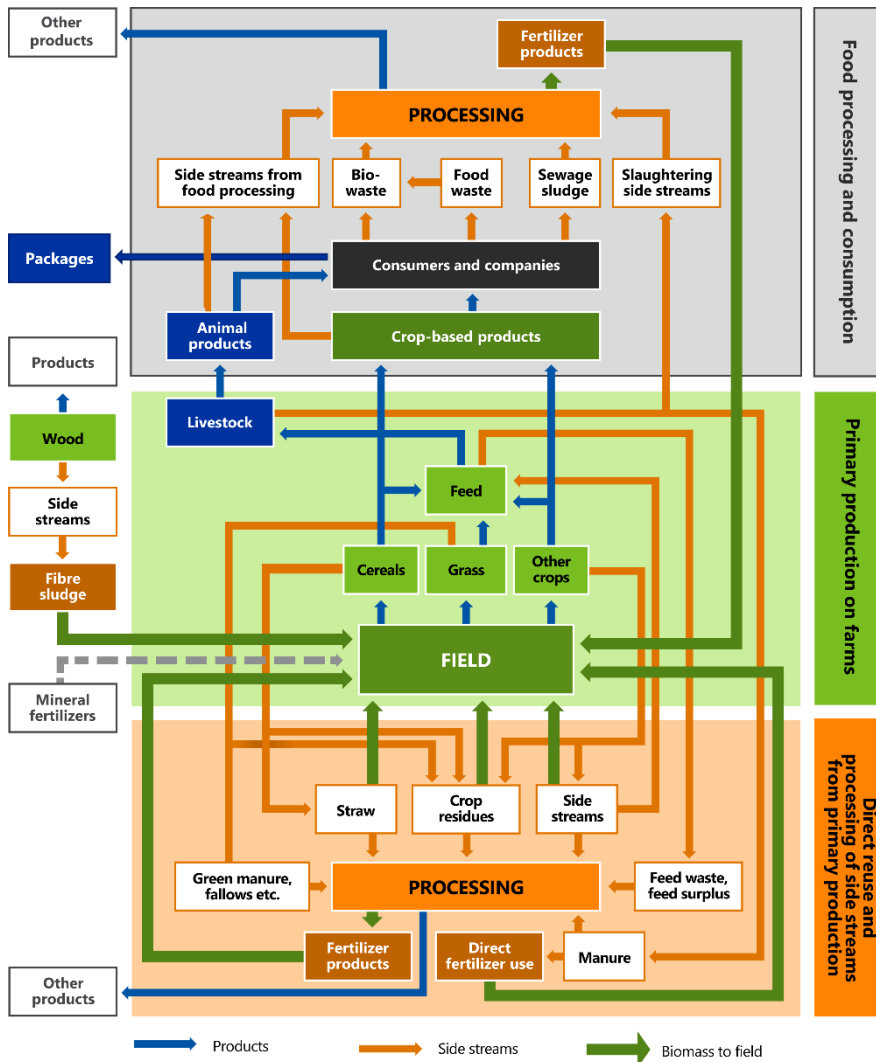

Figure 2. Systemic diagram of the food production chain. Based on a systematic analysis of all defined processes and their interaction, we analyse the different loops of carbon cycling in the agrofood system and consider the different operators related to the carbon chain.

Table 2. *The key data sources for the food chain circular economy.*

Theme	Data source
Field and crop data (1.1.)	IACS register Crop statistics Biomass Atlas
Crop based products (1.2.)	Production statistics of Luke Balance sheet for food commodities EU Price monitoring of agricultural products Statistics of Finland, regional and industrial statistics on manufacturing National Board of Customs Forkful of facts by the Finfood - Finnish Food Information Finnish Food and Drink Industries Federation Other professional and trade associations
Fertilizers (1.3.)	Register of operators in the fertilizer sector Statistics on mineral fertilizers sold in Finland Annual reports on organic fertilizer products Fertilizer data of farmers
Feed (1.4.)	Crop statistics on silage and hay Statistics on the manufacture of feed materials Annual feed declarations
Feed waste (1.5.)	No data
Livestock (1.6.)	Animal registers of the Finnish Food Authority Statistics on agriculture and production
Animal products (1.7.)	Agricultural production statistics of Luke Forkful of facts by the Finfood - Finnish Food Information Publications of professional and trade associations
Manure (1.8.)	Finnish Normative Manure System Biomass Atlas
Slaughter waste (1.9.)	YLVA database Honkajoki responsibility reports
Food waste (1.10.)	The report of the Food Waste Monitoring project and road map
Biowaste (1.11.)	YLVA database
Sewage sludge (1.12.)	YLVA database
Side stream processing (1.13.)	Environmental permits of biogas plants and other biorefineries

2.3 Batteries – data through the battery value chain

Sonja Lavikko, Marjaana Karhu, Sari Kauppi

The battery value chain starts with raw material production. Domestic production includes several battery mineral ores, such as nickel, cobalt, and copper, with the future addition of lithium and graphite ore production, which is planned to start within a few years. Through mineral processing, the desired minerals are liberated from the residue phases. Consequently, the main material flows generated by the raw material extraction phase are mineral concentrate (the product) and residue flows (mine tailings). Part of the concentrates are exported, while some are further processed in Finland into battery chemicals (metal salts such as nickel sulphate, cobalt sulphate, and lithium hydroxide).

Battery chemicals are used as raw materials for precursor cathode-active materials (pCAM) processing and further for cathode-active materials (CAM) production. As the next step in the value chain, battery cells are manufactured from battery materials (cathode materials, anode materials, electrolyte, and separator). The finished battery cells are then transported to battery pack manufacturers for battery pack assembly and battery management systems integrations. Battery systems are used in different end uses for electric vehicles, energy storage, and consumer electronics. At the end of the first life, there is a possibility for second-life applications and, finally, for battery material recycling. Through recycling, the battery materials can be returned into the cycle.

The battery value chain is presented in Figure 3, in which data is connected to each value chain step.

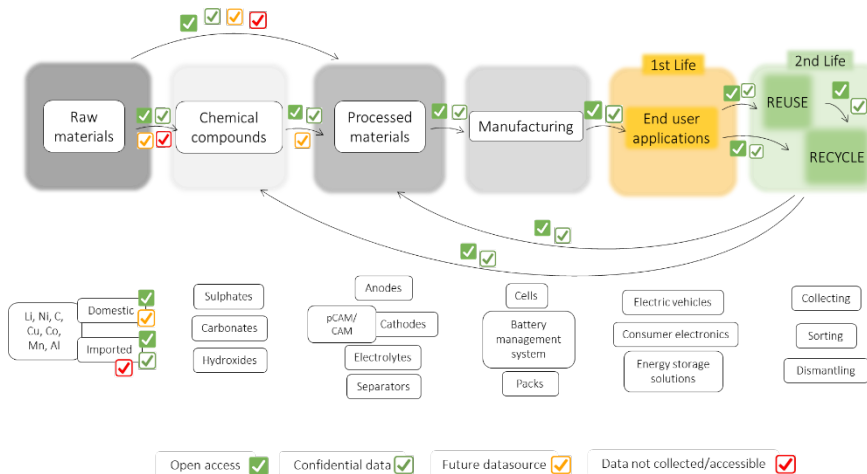

Figure 3. Data through the battery value chain.

The data source for raw materials, products, by-products, and production capacities of the minerals in the battery value chain is the Regional State Administrative Agency (Appendix A 2.1.) through its water and environment permits information service. Data sources for chemical production and imports include Registration, Evaluation, Authorisation and Restriction of Chemicals (REACH) (Appendix A 2.2.), Kemidigi (Appendix A 2.3.), and Substances in Products in the Nordic Countries (SPIN) (Appendix A 2.4.). The database for preventing waste generation containing substances of concern is the Substances of Concern in Articles as such or in Complex Objects (SCIP) (Appendix A 2.5.). Battery use phase data in the application is collected by a battery management system (BMS) (Appendix A 2.6.). Data sources for import, discarding, and recycling of batteries include the Finnish Safety and Chemicals Agency (TUKES) (Appendix A 2.7.), the Register for Market Surveillance, the Pirkanmaa Centre for Economic Development, Transport and the Environment (PIRELY), the Register for Producer Responsibility (Appendix A 2.8.), the Finnish Environment Institute (SYKE) (Appendix A 2.9.), and environmental permits.

Database sources utilize several cooperation platforms and initiatives, and some co-operate together (REACH–TUKES–ECHA–Kemidigi, PIRELY–SYKE). The stakeholders are also required to interact. Responsibility for reporting extends to manufacturers, importers, producers, users, and distributors, as well as industry representatives and NGOs. Transparency and predictability of regulatory activities is ensured by authorities. Certain databases cover international data while others target the Nordic (SPIN) or domestic (Kemidigi) markets.

The endeavour to provide up-to-date and open access data is great. The open access approach is, however, challenged by the aim to ensure a certain degree of anonymity of individual sources. Unfortunately, this aim leads to a somewhat general level of reporting and, in some cases, to unattainable data (see Figure 3). Another gap in the system is created by the procedure of defining products; requirements do not necessarily extend to all products, depending on their categorization. Harmonization of the requirements and their execution is still a work in progress.

2.4 Textiles

Pirjo Heikkilä, Hannamaija Tuovila

Textile production chains are global and, in their current state, quite unsustainable. There is an urgent need for product data and value chain information for tracking and traceability of textiles, but also to optimize the processing and recycling of materials. In a circular economy, the need for data and information is further increased, since they enable us to plan and design more sustainable textile systems, also enabling the recycling of products. The relevant data depend on the purpose of data utilization, as seen in Table 3.

Table 3. Relevant data determined at the CircDNet Textile Think Tank workshop (see <https://circinnovation.com/articles/data-is-king-in-circular-economy-of-textiles/>).

THEME	RELEVANT DATA
TEXTILE PRODUCTS – DATA OF ORIGIN	<ul style="list-style-type: none"> • Manufacturer of the product • Production country • Raw material information • Origin of fibre • The true LCA data on raw materials • Textile chemicals: colourants, colour class, colour durability for mechanical recycling
CONSUMER PRODUCTS, THEIR USE AND LOOP CYCLES	<ul style="list-style-type: none"> • Product information: material, production and logistics, size, style, use purpose • The environmental impact of the product • Renting: usage amounts, condition after use, maintenance, life cycle • Usage information: times in use, life cycle, users • Amounts of textiles ending up in recycling, municipal waste management • Methods of recycling • Information on why products are not recycled
WORK CLOTHING, THEIR USE, MAINTENANCE AND PRODUCT LOOPS	<ul style="list-style-type: none"> • The fibre/material standards that are met • The production country of the material • The country in which the clothing is assembled • The origin of the recycled raw material and the first point of use • Information on all materials/equipment on the clothing • The water used in fibres, CO₂ emissions, and energy consumption • The product standards that are met regarding reflector requirements, etc. • The mode of freight (sea, rail, air) • Clothing information: measurements, age, times per use, times per wash, times per repair/maintenance • In smart clothing with sensors: the body temperature, vital functions
RECYCLING AND MATERIAL LOOPS	<ul style="list-style-type: none"> • Material type (classes) • Content of textile: does it include plastic, metal, etc. • Condition of garment • Quality of textile • Detailed description of fibre composition (e.g., chemicals, colourants) • Country of origin • Amounts of textile waste • Local storage volumes • Points of return (location) • The employment impact of sorting

The circular textile system and material flows within it are very complicated and currently changing in Finland and in Europe. This change is occurring due to an EC-level decision stating that the targeted collection of textile waste and, consequently, more efficient recycling of textiles is to be started by all EU member states by 2025,

and in Finland by 2023. Based on current knowledge, a schematic of the expected activities and material flows in Finland can be made for the textile system when the separate collection of textile waste and textile recycling are started in 2023 (Figure 4). Currently, textile collection in Finland is focused on re-usable textiles and recycling, as textile material is minimal. Figure 5 presents a somewhat simplified picture illustrating the material flows for which we currently have at least some data available and those for which we should be able to have data in the future.

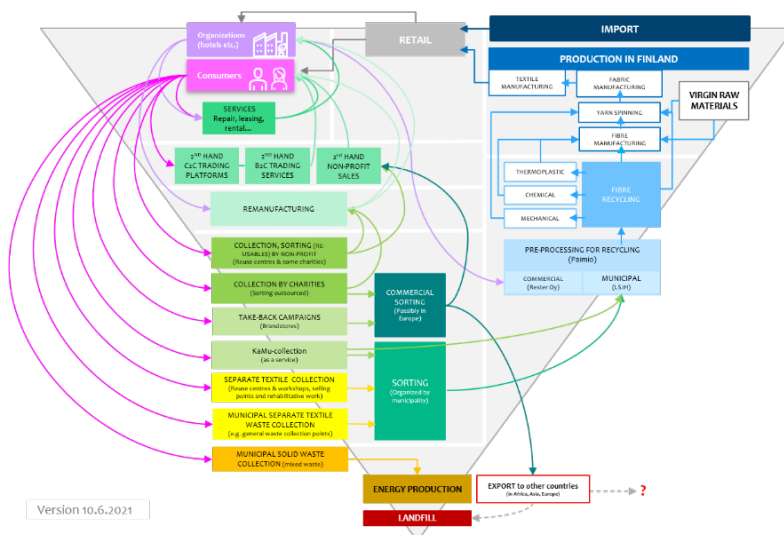

Figure 4. A detailed diagram to show different activities in a circular textile system.

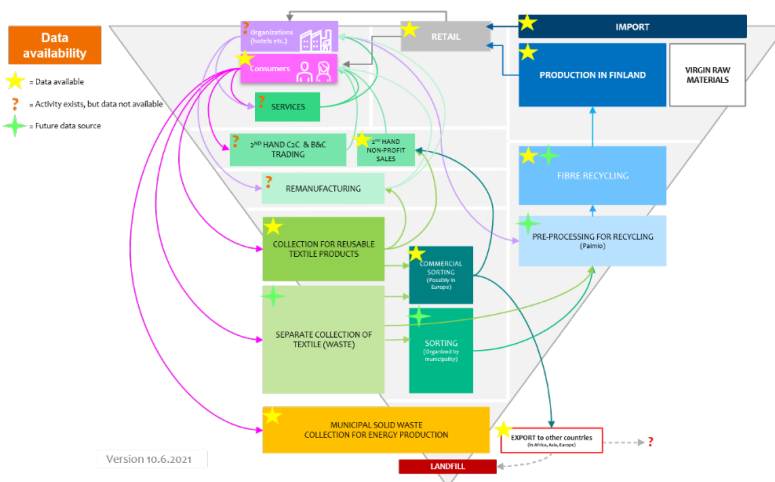

Figure 5. A simplified system diagram to show the data of material flows in a circular textile system.

In 2021, SYKE led a survey that mapped textile flows in Finland. Conducting such a survey was not an easy task, since even though some waste management-related data is gathered, there is no systematic collection of all the data needed for such mapping. These same challenges apply to circular textile data and information in general. Very few data sources are systematically collected and automatically updated. Information is collected periodically, for example, by textile organizations, or produced within surveys and projects when funding for these is available. Since the availability of textile flow-related data is limited to some waste-related data, and to obtain information needed for systemic understanding and planning of circular textiles, we need to rely on individual surveys. More information about textile data sources can be found in [Appendix A](#), Chapter 3.

2.5 Plastics

Tiina K. M. Karppinen

The 20-fold increase in the total production of plastics globally from the 1960s to 2015 (322 million tonnes) illustrates the dire need for a circular economy of plastics. It is estimated that one million tons of plastics finds its way to the world’s oceans each year. When produced and managed sustainably, plastics can, however, be very useful, for example in durable light-weight solutions or in extending the shelf life of food, thereby reducing the amount of food waste. (European Commission, 2018)

In this review, the focus is on end-of-life plastics and the use of plastics as secondary raw materials. The Finnish Environment Institute SYKE has developed a model for estimating the streams of plastic waste in Finland in the project ALL-IN for Plastics Recycling (PLASTin) and a mass balance for plastic waste flows in the project Novel method for the accounting of forest ecosystems and circular materials (ENVECO).

The estimate of plastic waste streams combines data from various national sources, such as the official national statistics on waste, data on producer responsibility systems, environmental compliance monitoring (YLVA database), and the data from the Customs (Table 4) ([Appendix A](#), Chapter 7).

Table 4. *The main datasets available on end-of-life plastics in Finland.*

Data set	Source
Plastic waste, mixed MSW, treatment types	MSW statistics, Statistics Finland
Plastic packaging waste	Producer responsibility statistics, PIRELY
Plastic packaging waste collected in regional collection points and arriving at terminals	RINKI
Waste PET bottles returned to deposit system	Palpa

Data set	Source
Storage of plastics waste	YLVA database
Plastics in mixed MSW	Suomen kiertovoima ry KIVO, Koostumustietopankki
Plastic sorted and recycled	Environmental permits of individual plants
Plastics exports	Uljäs database, Customs

The main data gaps in the secondary material flows of plastics in Finland include the amounts of plastic waste exported and imported, plastics ending up in the environment, for example via littering, and the rejects from the utilization of the secondary materials (Figure 6). In addition, there is great uncertainty in the material flows of combination materials containing plastics.

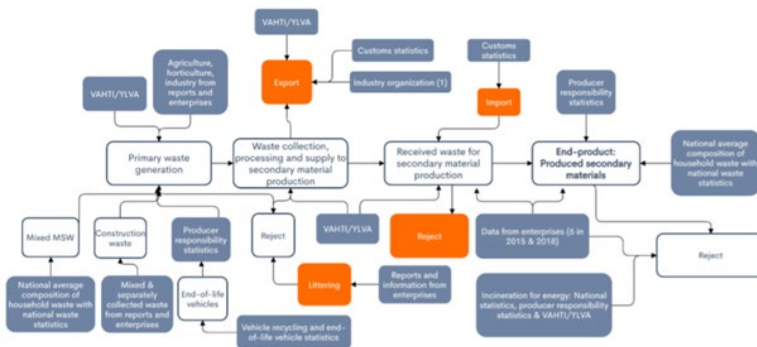

Figure 6. Data sources and data gaps for end-of-life plastic flows in Finland (Hurskainen, et al., 2021).

2.6 The built environment

Milja Räisänen, Tiina K. M. Karpinen

The construction sector is the third largest user of raw materials in Finland after forestry and mining and quarrying (Ruokamo, et al., 2021). In addition, it produces the second highest amount of waste when different sectors are compared (12% of all waste, 46% if mining and quarrying waste is not considered) (Statistics Finland, 2021b). Therefore, it is important to find circular solutions to promote the sustainable use of materials in the sector.

The use of data-based circular economy solutions will become available as digitalization progresses in the construction sector. Potentially, data can be utilized in favour of a circular economy, for example at different stages of a building's life cycle, from planning to waste management. EU and national initiatives promoting the twin transition, as well as some examples of digital solutions adopted in the construction sector, are presented in Section 4.4.3.

The built environment information system RYTJ is a new national data system currently under development. It is based on the objectives set in Prime Minister Sanna Marin's government programme on the digitalization of the built environment (Finnish Government, 2019). The data system will eventually contain all relevant information on building and land use planning submitted by municipalities. This includes permits, decisions, and restrictions, as well as data models on plans and construction sites. The information gathered in the data system can be used to promote the circular economy, such as in decision making when regional and property-specific uses are discussed, when municipalities or other building owners assess the need for repairs to their properties, and in services development for a certain area. More information on RYTJ is provided in Appendix A, Section 6.1.

When choosing construction products, environmental impacts can be better accounted for by using [CO2data.fi](#) ([Appendix A](#), Section 6.2.). This is an emission database for building products, services, and systems. In addition to carbon footprint and handprint information, the service provides information on, for instance, the recyclability and material efficiency of construction products used in Finland. It also shows the waste percentages on construction sites and the technical lifetimes of frequently replaced products. The service is open to everyone free of charge.

The amounts of construction and demolition waste are monitored by Statistics Finland ([Appendix A](#), Section 6.3.) and published annually with a delay of 1.5 years. Information on the recycling rate or waste treatment types are not available specifically for the construction sector in the waste statistics. However, the recycling rate is monitored in relation to the EU's targets in co-operation with SYKE and Statistics Finland. Local data on waste streams could enhance the utilization of construction and demolition waste. For better utilization of various side streams and wastes (incl. construction materials), the Ministry of the Environment and Motiva Oy have developed a platform called Materiaalitori for declaring these materials. For more information about Materiaalitori, see Section 4.4.2.

2.7 Primary mineral raw materials and mining waste

Jussi Pokki

Primary mineral raw materials refer to mineral raw materials that are directly sourced from geological deposits. These include metallic minerals (ferrous and non-ferrous minerals), industrial minerals (non-metallic minerals), aggregates (hard rock aggregates, sand, and gravel), and dimension stones. Mining waste refers to mineral waste formed in mining or subsequent processing of ore and has a potential to be utilized as a secondary raw material source. A great deal of data is available on the occurrence of primary mineral raw materials in the Finnish bedrock and on mine production. Data on mining waste would be particularly important for the development of a circular economy, but very little such data is available.

The Mineral Deposit database of the Geological Survey of Finland (GTK) is the most important source dealing with primary mineral raw materials in Finland. It contains detailed information on Finland's mineral deposits, such as the location, contained commodities, for the most significant deposits the estimated quantities of commodities (resources and reserves), and for mines the production volumes ([Appendix A](#), Section 4.1.). Mineral deposit information can be viewed in a browser-based online service 'Mineral Deposits and Exploration' at <https://gtkdata.gtk.fi/mdae/>. The data can also be downloaded from GTK's Hakku service at <https://hakku.gtk.fi/> for viewing with GIS software. The data is public and available free of charge. However, without advance permission from GTK, the data can only be used for certain personal purposes or for internal use within an organization. No permission is needed when the data is used in documents created for authorities, in scientific publications, and teaching materials.

In the case of mining waste, only the annual amount of waste rocks extracted from each mine is regularly stored in GTK's Mineral Deposit database ([Appendix A](#), Section 4.2.). This data is collected and published by the Finnish Safety and Chemicals Agency (Tukes), which is the mining authority in Finland. We are not aware of a public source of information on the formation of other mining waste. Accurate data on the location, quantity, and quality of available mining waste would be highly valuable, as it would facilitate the utilization of secondary raw materials while decreasing the consumption of primary raw materials.

GTK's Mineral Deposit database presents data at the level of individual deposits. In addition to occurrence-level data, country summaries are also important and can be used to make continental or global summaries. The European Minerals Yearbook at <http://minerals4eu.brgm-rec.fr/m4eu-yearbook/index.html> contains country-specific summaries of mineral production in different European countries (2004–2018), resources and reserves (2013), foreign trade (2004–2018), and key figures on exploration (2013) ([Appendix A](#), Section 4.3.). The same data is available in EGDI portal at https://data.geus.dk/egdi/?mapname=egdi_geoera_mintell4eu. This portal additionally contains data for the statistical year 2019 (production, resources and reserves, and exploration) and is more sophisticated as a user interface. It is noteworthy that resources and reserves for Finland in 2019 have been reported in a harmonized way using the UNFC reporting code.

Exploration data describe the efforts and results of companies aiming to discover new mineral deposits and/or new resources for known deposits. Tukes maintains a public Mining Register, which shows the areas where exploration is currently permitted. GTK maintains a spatial data product called 'Expired claim and exploration permits', which shows areas that have been licensed for exploration in the past ([Appendix A](#), Section 4.4.). In addition, reports on the results of mineral exploration, prepared by the exploration companies, can be accessed in this data product whenever available. Other exploration companies can build on this information when planning new exploration campaigns.

Data on undiscovered mineral resources is also available based on modelling efforts ([Appendix A](#), Section 4.5.). This refers to resources that are believed to exist at a depth between 0–1000 m in the bedrock, even though they have not yet been

discovered. The assessment only covers those undiscovered deposits that are believed to be economically exploitable. The assessments carried out by GTK cover undiscovered mineral resources (in metal tonnes) of 15 metals in 14 different mineral deposit types. The results do not show the exact location of the individual undiscovered mineral deposits but are presented per permissive area. These are contiguous areas where geological factors allow the presence of a particular type of mineral deposit. The data is public and freely available at GTK's webservice 'Mineral Deposits and Exploration'. The data can be utilized, for example, in exploration and land-use planning.

Data on Finland's foreign trade in various mineral raw materials can be found in the ULJAS database maintained by the Finnish Customs (<https://uljas.tulli.fi/v3rti/>) ([Appendix A](#), Section 4.6.). Data in the Uljas database can be used freely in every feasible way (also commercially) provided that the source is mentioned. Once the user has specified the data of interest, the application retrieves it from the database and displays it in the selected format.

Considering the circular economy, mineral production and imports define what has entered the circular loop. Data on reserves, resources, and undiscovered resources describe what could potentially enter the loop in the future – at a decreasing level of probability. Data on mineral waste and exports describe what has exited the national circular loop but could potentially re-enter the circular economy.

2.8 Waste

Tiina K. M. Karppinen

The official monitoring of the circular economy has a strong emphasis on waste-related data (Eurostat, 2021a). However, a circular design is needed to avoid the production of waste as far as possible and to maximize the utilization of waste materials. Data on waste is still needed, for instance, to assess the availability of secondary materials for more sustainable and circular production.

Data on waste can be found from many sources and databases. The national statistics ([Appendix A](#), Section 9.1.) describe the general picture and trends in waste generation and utilisation (Statistics Finland, 2021b). Statistics rely primarily on data provided by producers and handlers of waste in the national database of the environmental compliance monitoring system (YLVA) ([Appendix A](#), Section 9.2.) (Ministry of the Environment, 2021a) and the producer responsibility statistics collected by the Pirkanmaa Centre for Economic Development, Transport and the Environment with producer responsibility organisations ([Appendix A](#), Section 9.3.) (Pirkanmaa Centre for Economic Development, Transport and the Environment, 2019). The trends in the amounts of waste and recycling according to the National Waste Plan are monitored by the Finnish Environment Institute SYKE ([Appendix A](#), Section 9.) (Finnish Environment Institute SYKE, 2021).

In addition to these, there is data on the transboundary shipments of waste, collected by SYKE ([Appendix A](#), Section 2.9.) and the Finnish Customs ([Appendix A](#), Section 4.6.). Some waste-related data can also be found in other sources, such as Natural Resources Institute Finland's data on food waste and the Food Safety Authority's database on fertilizers ([Appendix A](#), Section 1.). The national advocacy organisation for the public waste management sector, Suomen Kiertovoima ry KIVO, also collects data on picking analyses conducted on mixed municipal solid waste from households (Suomen Kiertovoima ry KIVO, 2021). Finally, different research projects provide a closer look at certain materials, waste streams, or locations, or model the system further.

2.9 Industrial production and material utilization

Mika Naumanen

In a working circular economy, the demand for natural resources as raw materials decreases as they are replaced with recycled materials. Good planning can also improve the efficiency of production processes and extend the service life of products, and these measures are also reflected in a decreasing use of virgin raw materials. Currently, few statistical classifications distinguish the use of raw materials by source, but natural resources taken into use in the economy can be measured with domestic material use.

The industrial production materials and supplies survey contains purchasing information on the materials and supplies used in the manufacture of goods in industrial production. Purchasing information is requested from informants on an item-by-item basis. Purchased materials and supplies refer to raw materials, semi-finished products, additional materials, and supplies purchased from outside the enterprise for production during the calendar year, for the manufacture of goods in industrial production, regardless of the year of use. A more detailed description of these sources can be found in [Appendix A](#).

2.10 Other data sources for circular design approaches

Tiina K. M. Karppinen

In addition to the thematic data sets presented in the previous sections, numerous other data sources can be useful in circular design approaches. Some relevant data can be found, for example, in SYKE's Liiteri database for geographic data, SYKE's data on water accounting, and Statistics Finland's dataset on the circular economy in business (see [Appendix A](#), Chapter 8.). Many of these data sources are commonly used in planning or monitoring, but they already contain and increasingly include data that can be utilized from the circular design perspective. The data is often scattered in many sources and under varying topics, which hinders its utilization.

3. New tools and technologies for data management, distribution, and value addition

Many innovative solutions, new products, and processes developed from material flows that have previously gone to waste exist in Finland. One example is Rens sneakers, a Finnish start-up, which uses recycled coffee grounds and recycled plastic as raw materials. Another is the candymaker Fazer's new xylitol factory, which uses oat side streams – worth investing 40 million euros in a small-town suburb. These biomaterials have earlier gone to waste, but with these innovations, their life cycles have been extended and add value to new products. It takes a creative mind, data for calculations, and the necessary resources to make these types of innovations happen.

Closed-loop economies, where nothing goes to waste, can be reached by individuals who see an opportunity in a pile of trash. However, when a company or an innovative individual is interested in exploiting circular economy data, where can this data be found?

This chapter describes the current state of the circular economy data in Finland, introducing the past and current methods for data collection and management, as well as the emerging solutions that could be growing to be mainstream solutions in the future. We discuss the challenges and opportunities of these data sources.

We also introduce several tools and technologies that guide and, sometimes, restrict the use of circular economy data, guidelines that aim to enhance the production and use of circular economy data, and incentives that have been introduced for manufacturing firms, businesses, and customers to motivate them in better production, sharing, and usage of circular economy data and steer the markets and customers towards a greener future.

We describe the circular design strategies of narrowing, slowing, closing, regenerating, and informing, and methods to design and assess the circularity. Life cycle assessment (LCA) is thoroughly discussed, as well as social LCA and environmental life cycle costing (LCC). The risk assessment of product creations includes safety in design, safety in production and safety in the marketplace. We also introduce the multi-criteria decision-making analysis and ROI calculation tool. Design for Circular Economy & Design for X are presented in detail.

The circular economy business models introduced by Paavo Ritala and Nancy Bocken present six strategies for business organisations in the circular economy. Regarding resource strategy, organisations can choose narrowing, slowing, and closing of material loops, and closed or open innovation strategies. (Bocken, de Pauw, Bakker, & van der Grinten, 2016; Bocken & Antikainen, 2018; Geissdoerfer, Morioka, de Carvalho, & Evans, 2018; Bocken & Ritala, 2021)

3.1 Data collection, management, and distribution

Katja Hilska-Keinänen, Henri Pitkänen

As shown in the descriptions of different circular economy datasets in [Appendix A](#), there are various methods for data collection, management, and distribution. Many data sources that are created, collected, and processed in Finland can also be exploited from the circular economy perspective. The data collection methods vary from traditional, even old-fashioned, to very modern methods. We have data that is manually typed into databases, and we have intelligent sensors reading and sending data automatically. To use data for value creation, it needs to be accessible, understandable, transferable, and trustworthy.

Many of the data sources have been established from a very different angle than that of a circular economy. When societies have faced the necessary move towards a circular economy and the closing and slowing of production loops, the data traditionally used for monitoring purposes has suddenly also become interesting from the circular economy perspective. Material sources that have previously been considered waste are now seen as promising raw material for new product solutions. The side streams of mines, forestry, and the food industry are seen as opportunities for innovation and new ground-breaking design items and processes worth investing millions of euros.

Data collection, in its very basic form, covers any means by which some information (data) is collected with any method, for any purpose. Data collection can be automatic or very thoughtfully managed. It might be as simple as an automatic electricity meter or much more complicated, such as the effort required in the national food waste registry, where participants use personal diaries to gather information on food usage and food waste.

The technologies used for collecting and analysing data can be manual, automatic, instrument-based, done with satellites, other remote sensing and scanning methods, probes, equipment sending data automatically, and so on. Data may be sent without the user even realising it, in which case data sending comes without any use phase effort. In other cases, the collection of data or reporting of it to databases might be very cumbersome.

In any case, the collected data will not go anywhere or be used to create any value unless it is somehow managed. There are many private collections and unmanaged data sources lying unused in individual's and organisation's drawers. This data might be interesting from the circular economy, sustainability, or other environmental perspectives, but will never be managed, distributed, or exploited in any way, as the data is unknown to outsiders, non-readable, non-standardised, and therefore unmanageable.

Data management refers to systems, capacities, and automatic and human resources that are behind the very essence of data collection: to ensure that the collected data is readable, reachable, searchable, transferable, and manageable from one medium to another, year after year. Data management is also the tool to

ensure that data is accessible in both technical and cognitive terms – be it machine readable, interpretable by humans, or both.

From the circular economy perspective, data management is a medium for bringing together the actors of the circular economy: sources, providers, producers, administration, and those who could benefit from the use of this data. Data management is a way to open the possibilities of value creation from the data provided, and the managing bodies should therefore understand the interests that could arise from users of the data.

An eye-opening example is the government registries related to compensation for farmers. These were originally created for control and monitoring, but could also be used in circular economy innovations, when approached from a different perspective. It takes a creative mind to see the circular economy data opportunities in these registries, but also a lot of work to make the data approachable, usable – and attractive.

Data distribution is the channel to ensure that the data collected and managed is also understandable and usable. Raw data is presented in a way that enables human interpretation and machine learning. Within the data sources described in [Appendix A](#), data distribution has been ensured, for example, by developing map-based services (e.g., the Biomass Atlas), where thematic maps represent the data in a visual form.

These map-based data distribution solutions enable easy access for the user and a personal feel to data representations, as it is possible to surf through the whole country when browsing for interesting data sources, solving problems of material collection, or calculating the most optimal siting for a circular raw materials-based factory. Another widespread data distribution solution is a database, for example YLVA and KIVA for textile waste.

At present, no data is available on how many innovations have grown from these shared, open data services. Are there problems with data usage or gaps in data that are related to data collection, data management, or data distribution? These issues should be analysed and government agencies could arrange hackathons for innovative firms and individuals to challenge them in value creation from distributed data, to see whether the distributed data is truly valuable and study different approaches to it. The descriptions of individual data sources in [Appendix A](#) of this report also contain comments on the properties of these data sets.

3.1.1 Current state of circular economy data collection, management, and distribution in Finland

With all this data gathered in a wide array of platforms, are we content with the current situation? What should be done next to promote the use of these data sources and create better circular economy solutions, making sure that nothing valuable goes to waste and we can live on this planet without using up all its renewable resources by the end of August each year?

The current state of circular economy data collection, management, and distribution in Finland is partly very well managed and has many strengths, but there

is also room for improvement. Data sources are wide and varied, and the main challenges to be tackled are not only those of findability, accessibility, searchability, and reusability, but they are also heavily intertwined with motivation, resources, and responsibility issues.

The strengths of the circular economy data lie in the wide network of actors participating in the collection and sharing of the data. Some of the data have been gathered and monitored for years, while other sources are late arrivals. However, the new data sources may be better designed and more relevant than the traditional ones regarding the circular economy perspective. Many of the data sources listed in this report have originated from other than circular economy needs, while others have been developed for recycling and other circular economy purposes.

The weaknesses in circular economy data collection and management could be rightly termed “challenges” in this case, as the weaknesses are well known and many earlier studies and reports have analysed these aspects of circular economy data. It is not a lack of knowledge that weakens the data approaches to the circular economy, but the challenges with co-ordination, ownership, and resources.

The challenges in national data management for circular economy solutions arise from the lack of centralized circular economy data governance and commonly agreed standards and incentives for data collection. Circular economy data has many owners, from private entrepreneurs to small manufacturers, large factories and facilities, as well as governmental organizations, and these organizations have very different possibilities and motives for collecting, sharing, and opening their circular economy-related data.

Also, the question remains of who the owner of this agenda is and whether there should be a centralized administration for circular data management. There is an urgent need for a governing body that could co-ordinate the governance of circular economy data, keep track of international developments and European standards, and match these with the national agenda and local contexts.

The current situation and challenges for the further development of the Finnish circular economy are documented and discussed in an earlier report entitled “Kiertotalouden strategisen ohjelman arvio” published in early 2021 (Hildén, et al., 2021). The report describes the platform economy as a technology and business model that has great potential for supporting and developing a circular economy. A circular platform economy could be seen as an ideal solution, when technology meets customer behaviour and deeply affects the current ways of consuming, in which ownership has been private and product lines linear. The report also mentions the need to form a circular economy community.

As described in previous sections, the lack of data sources is not the first challenge to be tackled in the circular economy. To describe the methods that are currently used in Finland for collecting, managing, and processing the data, Table 5 presents some of the most promising circular economy data and their properties. The complete table is available as [Appendix B](#), which is a condensed tabular presentation of the detailed descriptions of individual data sources presented in Appendix A. It is noteworthy that the types and sources of data, technologies used, and data access are not standardised or regulated across the various data sets from

the circular economy point of view. Instead, technological solutions have been designed one by one to serve the data collection task at hand, based on the needs of the owner or manager of the data at that time. The tabular presentation of the data sources and their various attributes, including technological solutions, in [Appendix B](#) can be used to gain an overview of the complexity of the issue and to identify and prioritize challenges to be tackled, which would help to advance the use and value creation based on circular economy data.

Table 5. Example of the data table.

Data	Description	Sources of data	Data set properties	Data access
1. Food and carbon				
1.1 Field and crop data - IACS register	<p>Common agricultural policy of European Union has been applied in Finland since 1995. Approximately 90 % of farmers have committed to the system and it covers more than 90 % of field area.</p> <p>The field register (part of IACS) of Finnish Food Authority has approximately 200 different plant or land use codes for different types of field use.</p> <p>Though the data is collected for administration and control purposes, it can be used also to calculate biomass potentials, monitor land use, estimate nutrient demand in different areas etc.</p>	<p>Finnish Food Authority collects register of cultivation plans made by Finnish farmers. The original data owner is therefore the farmer. The integrated administration and control system, IACS is a register for management for payments to farmers. The farmer reports every spring the cultivation plans for the coming growing season.</p>	<p>The time span for field parcel data is from 1995 to the current year. There might appear new plant codes when terms for common agricultural policy (CAP) change. Also, some old codes might go out of use. Usually, the continuity of the codes is good, and it is possible to form continuous time series.</p>	<p>Public and free. Fee for research purposes.</p>
1.1 Field and crop data - crop production statistics	<p>Crop production statistics contain harvest data on Finland's most important field crops, including cereals (wheat, rye, barley and oats), turnip rape, potato, sugar beet and herbage crops. Detailed description of the statistics can be found at https://stat.luke.fi/en/mjasto/125/kuvauks/1128.</p>	<p>The Natural Resources Institute Finland produces and processes Finland's statistics on food and natural resources. Producing statistics about agricultural production is one of its basic tasks as statistical author. Statistic data can be found at Natural Resources Institute Finland website https://stat.luke.fi/en.</p> <p>Agricultural statistics are produced to follow and understand agriculture and its development and trends. It is needed for decision making e.g., for food security, regional development, and environment protection.</p>	<p>Data is available for the whole Finland and by Centres for economic development, Transport and the Environment (ELY-Centres). Data is available from the 1920s onwards. The statistics contain harvest data on Finland's most important field crops. The cereals included are spring and winter wheat, rye, malting barley, feed barley, oats, mixed grain and other grains. Other plant groups are turnip rape, oilseed rape, caraway, peas, table potatoes, early potatoes, processed food potatoes, starch potatoes, other potatoes and sugar beet. The herbage crops included are timothy seeds, hay, fresh grass, silage (fresh and dried) and reed canary grass. The statistics also contain harvest data for green chop, wholegrain silage and fresh silage. Data on the field crop harvest is presented in both kilos per hectare (10,000 m²) and as total yield in millions of kilos. The dry matter content of harvested herbage is also given.</p> <p>The statistics are updated annually.</p>	<p>Crop statistics are public, open and free to use. Reference to mention is OSF, Natural Resources Institute Finland, Crop production statistics.</p>

3.1.2 Data for a circular economy comes from multiple sources

Government research institutes and administration receive data from a variety of sources or use their own resources to collect data for a specific purpose. A vast amount of data is automatically collected using measuring instruments, but stakeholders also input data to registries manually.

Valuable data can sometimes be obtained through sampling methods to arrive at estimates of the behaviour of a larger population for generalizations. In the case of food waste, for example, selected households have been asked to keep a waste diary, and the catering industry reports its food waste with similar methods. The data collected with this method might not be very accurate and readily transferable for further use and value creation, but it provides an order of magnitude estimate of a selected behaviour and phase in the flow of materials. The food diaries and food waste reporting are good examples of citizen science. Households are also sent surveys related to consumption. Anyone can produce valuable data to support common decisions.

Data collected with sensors and other automatic digital measuring instruments might be overwhelming in its quantity but challenging from the value creation perspective. With data, it is relevant to question the quality versus quantity and accuracy versus usability. For an individual or an organization, it is essential to be able to trust the quality of data available for investment purposes, but easy access to data may be an even more important factor when it comes to the initial planning of new circular economy solutions.

3.1.3 Case: The FAIR principles of research data as a model for circular economy data management

The FAIR principles of research data were created from the needs of better data management for the research community and the large number of actors involved in it. While one of the original motivations of the FAIR principles was the need to ensure transparent science, the relatively straightforward and intuitive principles of the research data ecosystem could possibly be used as a model for the circular economy data ecosystem.

The community around research data has succeeded in launching the FAIR data principles after intensive work that already started in 2014. The FAIR acronym stands for Findable – Accessible – Interoperable – Reusable. The FAIR principles are well distributed and known among research organisations. They are a standard skill required when recruiting data management professionals who support researchers in data management. It could even be argued that one cannot work in research data support without mastering the FAIR principles. It is possible that similar standards and requirements could be developed for circular economy data.

THE FAIR DATA PRINCIPLES

One of the grand challenges of data-intensive science is to facilitate knowledge discovery by assisting humans and machines in their discovery of, access to, integration, and analysis of task-appropriate scientific data and their associated algorithms and workflows. Here, we describe FAIR – a set of guiding principles to make data Findable, Accessible, Interoperable, and Reusable. The term FAIR was launched at a [Lorentz workshop](#) in 2014; the resulting FAIR principles were [published](#) in 2016.

To be FINDABLE:

- F1. (Meta)data are assigned a globally unique and eternally persistent identifier.
- F2. Data are described with rich metadata.
- F3. (Meta)data are registered or indexed in a searchable resource.
- F4. Metadata specify the data identifier.

To be ACCESSIBLE:

- A1. (Meta)data are retrievable by their identifier using a

standardized communications protocol.

A1.1. The protocol is open, free, and universally implementable.

A1.2. The protocol allows for an authentication and authorization procedure, where necessary.

A2. Metadata are accessible, even when the data are no longer available.

To be INTEROPERABLE:

I1. (Meta)data use a formal, accessible, shared, and broadly applicable language for knowledge representation.

I2. (Meta)data use vocabularies that follow FAIR principles.

I3. (Meta)data include qualified references to other (meta)data.

To be RE-USABLE:

R1. Meta(data) have a plurality of accurate and relevant attributes.

R1.1. (Meta)data are released with a clear and accessible data usage license.

R1.2. (Meta)data are associated with their provenance.

R1.3. (Meta)data meet domain-relevant community standards.

It is possible that the management of circular economy data could benefit from adapting the FAIR principles that the European Union has launched for research data. FAIR principles are well developed and communicated throughout university and other research organization networks and supported in their home organizations with information services and libraries or other research support staff. It may be possible to implement similar support structures to promote circular economy data. This solution is discussed in more detail in the recent report “Uusi suunta – kiertotalouden strateginen edistämishjelma” (“New direction – strategic program for promoting circular economy”), (Valtioneuvosto, 2021) and in Section 4.2.

Data sharing platforms as business opportunities

Open data can be used by individuals, start-ups, and other organizations to develop their own applications. Also, enabling individuals to share data and connect to others through this data and information could be a profitable business opportunity. As an example, one of the richest men on earth has collected his fortune by letting other people sell and buy merchandise in his web shop. Many platforms that enable people-to-people or business-to-people solutions have grown significantly in both size and variety.

As an example of platforms for the circular economy, the mission to reduce food waste has been well received by individuals. An app called ResQ has grown popular in large cities such as Helsinki, Turku, Tampere, Lahti, and Rovaniemi. With ResQ, restaurants can sell their excess meals at a lower price to customers, who can search for discounted meals based on location. The ResQ app does not utilize

governmentally collected and shared open data but it grows from the same agenda of food waste reduction. The same agenda has been capitalized by Fiksuruoka.fi and Matsmart, both selling excess food stock to customers via easy-to-use websites. It could be useful for government organizations to study the data generated with these types of businesses to be more aware of the value of these applications and service innovations. Materiaalitori (“Materials marketplace”, described in more detail in Section 4.4.2.) is a good example of an administration-led recycling platform.

Opening data involves challenges

At present, not all data repositories and data streams are open for anyone to use. This is to some degree related to the challenges related to open data services. Even if it would be technically possible, opening all the data available to everyone is not straightforward. In particular, making data public and open includes responsibility and security issues for both business organizations and the government.

For business organizations, opening their production data, for example, or monitoring data for the water quality in a nearby lake, could be an issue for sensitive business information, reputation, and stakeholder relations. It is possible for the data to be interpreted incorrectly, and the data can be exposed to manipulation. Sensor-based real-time environmental data is prone to short-lived excursions and the sensors may record events that are not the result of the activities of the sensor owner. These types of issues may discourage commercial companies from sharing their data openly, even if the technology would enable it.

Open data also involves ethical issues. Data containing or easily linked to personal details, for example farmers’ personal data, may not be shared without a valid reason, and this is well considered with the authorities. The raw data is not shared without specific requests, and the openly shared data is combined or anonymized in a way that it will not harm the providers.

The openness and accessibility of data alone does not guarantee the use of data. The usability and interpretability of data are very important from the value creation perspective. Furthermore, awareness of available data should be ensured with marketing and communication activities. The vast amount of data made available by governmental organizations might not be well known among business organizations and innovative individuals. The usability of data includes easy-to-use interfaces and interpretability of the retrieved data, but also fast response times, which requires human resources.

For commercial purposes the **licensing of data and its reusability** (conditions for use) should be easy to understand. The usability of data and other available information sources should be supported with dedicated professionals, for example information services and information retrieval professionals, along with researchers and developers who are responsible for the data collection.

The availability of data is rather well developed in Finland. However, a large amount of rich data is closed to various systems and databases. Interfaces should

be opened for everyone to use. Locked data is a major drag on the development of new applications, technologies, and markets. Harmonizing legislation so that organizations are encouraged to open their data could remedy the situation.

3.2 Advanced technologies enable value creation in a circular economy

Kristiina Valtanen, Hannu Tanner

Digital leadership is one of the European Commission's main goals alongside climate neutrality. This twin transition of green and digital change comprises an idea that climate-friendly modernisation efforts are required to ensure that Europe's industry stays competitive in global markets. The European industrial structure is already undergoing a deep transformation driven by digital and other innovative technologies and new business models. Generally referred to as the Fourth Industrial Revolution, several physical, digital, and biological technologies (Figure 7) can be used together to provide disruptive combinatorial effects. The outcomes can significantly facilitate the transition to a circular economy, for example, by improving how materials are sourced, managed, and valued. (World Economic Forum, 2019)

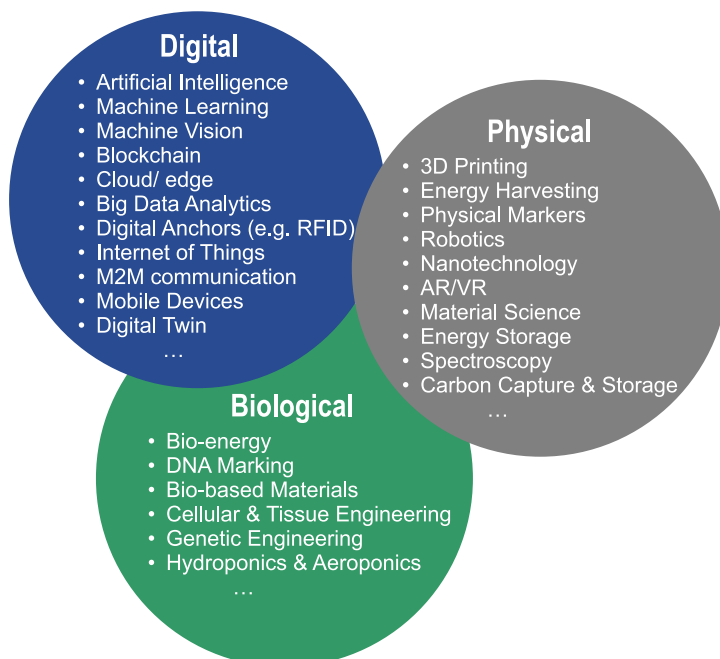

Figure 7. Technologies of the Fourth Industrial Revolution. Adapted from World Economic Forum (2019).

In the process, adequately steered digitalization can particularly be seen as an enabler and accelerator of positive change, contributing to a system-wide transition by, for example, “enhancing connectivity and the sharing of information across the value chains, making products, processes and services more circular, empowering citizens and consumers to contribute to the transition and improving the implementation of policies needed for a digital circular economy” (Hedberg & Šipka, 2020). According to ECERA European Circular Economy Research Alliance, (2020), the evolution towards circular solutions can be achieved by further harnessing the digital tools in:

- **Processes:** to allow higher efficiency and circularity in the processing of materials and manufacturing of products
- **Products:** to allow the tracking and tracing of products and components, value chain optimisation, the development of products as a service, and to increase reuse, repair, refurbishment
- **Platforms:** to connect consumers and producers, allow the development of services and dematerialisation, and facilitate industrial symbiosis

Advanced technologies are expected to offer enormous growth potential for Europe. Technologies such as the Internet of Things, artificial intelligence, blockchain and other ledger technologies, as well as robotics and 3D printing, are all mentioned as opportunities that will enable European industry to expand its leadership. As depicted in Figure 8 from the manufacturing industry, these technologies, among others, are relevant with respect to resource efficiency and the transition towards a circular economy. It is noteworthy that the digital technologies need to be aggregated to increase the operational maturity of industry to leverage more advanced functions for decoupling value creation from resource consumption. Thus, to achieve advanced resource optimization capabilities that have self-organizing or self-deciding features will require a comprehensive set of technologies for data collection, integration, and analysis. (Kristoffersen, Blomsma, Mikalef, & Li, 2020)

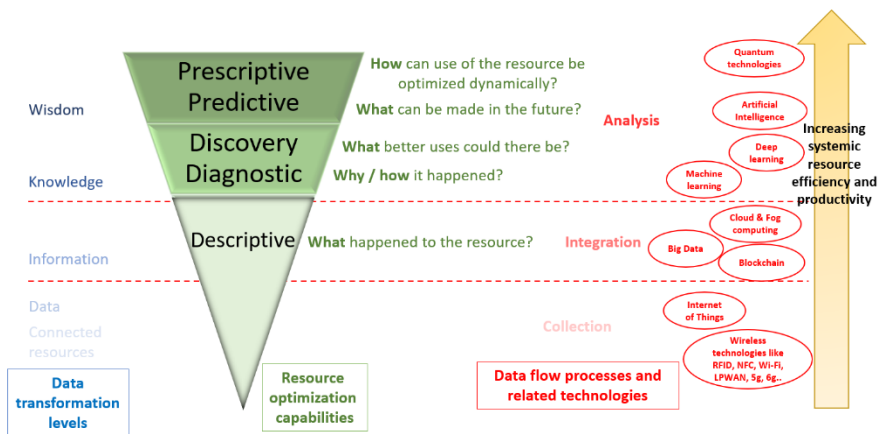

Figure 8. Advanced resource optimization requires technologies for data collection, integration, and analysis. Adapted and merged from Kristoffersen, Blomsma, Mikalef, & Li (2020) and Traficom/Deloitte (2020).

Perhaps the most cross-cutting technological use case related to the circular economy is the tracking of resource flows and efficiency. While the use cases differ greatly between industrial domains, the tools for monitoring material and product flows at the macro-level consider the circular economy from an economy-wide perspective. These can help in capturing system-wide effects and assessing whether absolute reductions in resource use and waste flows have been achieved (European Environment Agency, 2020).

The principles of tracking can be applied to both raw materials and ready-made products or components. Digital solutions can provide stakeholders in a value chain – such as consumers or recyclers – the specific information that they require to obtain, use, maintain, repair, reuse, or recycle a particular product in an optimal way. The more complex and valuable the product is, the more likely it is going to be worth tracking throughout its life cycle.

In order to be tracked, the product needs to be identifiable. Depending on the product and the use case, the level of required identity may vary from identifying the material used and the producer to identifying the product model, the production lot, or even the individual product. This requires including some type of label, marking, or device – which should be digitally readable – into the product or product packaging. This identity, as well as data related to the activity being recorded, needs to be stored in a secure and efficient way, protecting the interests of the stakeholders involved. Furthermore, the data needs to be transformed into knowledge that benefits the value chain and presented to the relevant stakeholders in a practical format, while still protecting the privacy and security of individual users.

3.2.1 Case: IoT can multiply opportunities for value creation in a circular economy

An Internet of Things (IoT) system is a network of physical objects such as devices, vehicles, and buildings that are embedded with electronics, software, sensors, and network connectivity, giving these objects an ability to collect and exchange data. IoT consists of numerous technologies. Small, embedded devices as well as advanced control and automation systems can be connected, for example, via Ethernet or using wireless technologies such as RFID, NFC, Wi-Fi, 5G, or LPWAN, depending on the requirements of the application. In addition, “things” must be addressable so that they can be referred to.

There are several technologies and standards for creating unique identifiers for products, devices, and other objects. For instance, IPv6 provides a large enough address space to meet the requirements of Internet-connected IoT devices, and an EPC (Electronic Product Code) saved in an RFID tag enables the identifying all things uniquely. In recent years, more and more development work has focused on increasing the intelligence of IoT systems using, for example, artificial intelligence and machine learning techniques (described in more detail in Section 3.3.1).

Depending on the application and its requirements and limitations, the intelligence can be implemented in an IoT device itself, on its fog or in the cloud. In the future, the emergence of open IoT systems and data markets will provide increasing opportunities for data analysis and decision-making, as well as system autonomy, self-organisation, and context awareness. This may significantly facilitate the development of circular economy systems that require a cross-organizational, systemic view.

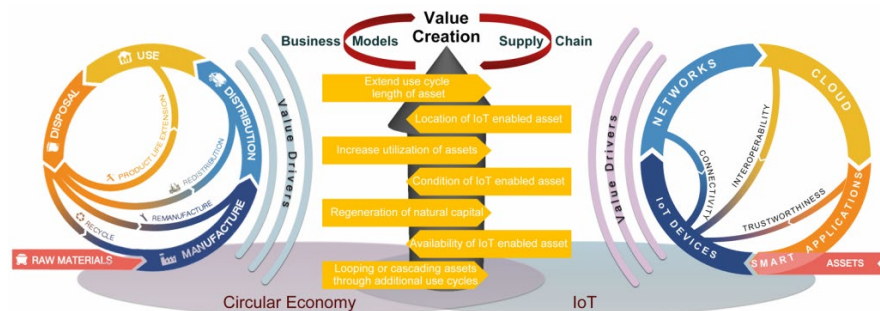

Figure 9. CE-IoT, “A Framework for Pairing Circular Economy and IoT.” <https://www.ce-iot.eu>.

3.2.2 Case: Automatic identification methods form the foundation for efficient product and material data collection

The implementation of a circular economy requires methods for the automatic identification of objects that are robust enough to last over the life cycle of the

product. Only then can full traceability be realized for both the product and its raw materials. Ideally, not only the main product, but also each smaller part of the product that requires a post-use phase process of its own would be individually identified. In addition to robustness and a small size, such an approach requires that the added cost of the identification mechanism remains low. It is also important that neither the insertion of the means of identification nor its reading add complexity or slow down the handling processes excessively. Technologies of automatic identification include optical codes, radio frequency identification (RFID), and, for instance, chemical markers that can be used to identify various raw materials.

Being the oldest of the technologies of automatic identification, **optical codes** such as the EAN bar code or the QR code (Figure 10) are widely used solutions for many applications. Methods of optical identification are still evolving as, for example, machine-vision-based pattern recognition falls under this category. The increased computing power and memory, together with high-quality, high depth-of-field cameras make it possible to use individual features of objects themselves as a means of identification. Additionally, hyperspectral cameras can be used in identifying materials, such as different types of textiles and fibres. More traditional and simpler implementation of object recognition is the automatic reading of text and numbers, such as the automatic reading of license plates of cars in parking buildings. Smart phones with high-quality cameras and high computing power enable many new consumer applications with optical identification.



Figure 10. Optical bar codes (left) and a QR code (right).

The most popular form of machine-readable optical code is a printed bar code or QR code, attached to an object as a label sticker or by direct printing. The code can also be etched, milled, or engraved by laser. Laser engraving of a QR code or a dot matrix is often used with metal parts. Dot matrixes can also be implemented by punching. Optical codes can also only be visible under ultraviolet or infrared light, making them invisible to the human eye.

Considering simple printed optical codes such as bar codes, their clearest advantage is low price. For product packages that anyhow have printed text and

figures on them, an optical code does not cause any extra cost, and it can be reprinted into the product wherever and whenever needed. Optical codes do not typically affect the recyclability of a product in any way, as they do not contain any harmful or problematic substances. Therefore, optical codes are well suited for many consumer products. The disadvantages, in turn, include a relatively short read range and the physical vulnerability of the code tag. Additionally, the reader must have a clear line of sight to the optical code.

In principle, any technology that utilizes radio frequencies as the way of transferring identification information from an object to a reader device can be referred to as **radio frequency identification (RFID)**. In practice, however, RFID typically refers to passive RFID technologies. A passive RFID transponder or tag does not contain any internal source of power but extracts the energy it requires from the electromagnetic field emitted by the reader or interrogator. Consequently, the tags are structurally simple and extremely long-lasting in the sense that there is no battery that would expire or need replacement.

RFID technologies can be categorized according to their operation frequency into three classes: low frequency (LF), high frequency (HF), and ultra-high frequency (UHF). In practice, the use of LF tags has been limited to animals and people, and it seems unlikely they will have a significant role in the circular economy. Over the past years, HF technology has gained popularity on the consumer market due to its use in the **near-field communication (NFC)** concept. An NFC reader as a standard feature of a smart phone, as well as many practical everyday applications, have made the concept successful.

The approval of the ISO standard (EPC Gen 2) provided a boost for **UHF RFID** technology, as the end users could finally invest in an internationally standardized systems instead of choosing between the many proprietary systems in use before this. **RAIN RFID** (<https://rainrfid.org/>) is a global alliance that promotes standardizing the way UHF RFID-based data can be stored, managed, and shared via the Internet. The most common type of RFID tag for both NFC and UHF is a label sticker.

RFID technology is still being developed further. As RFID enables different form factors for the tags and embedding tags into products, **special RFID tags** can be designed for applications for which the standard label or hard tags do not suit. For example, textile-based UHF RFID tags have been developed for the textile industry (Figure 11), while nail-shaped and wedge-shaped tags that can be hammered inside timber are available in different sizes and as NFC and UHF versions. RFID tags can be hidden inside a product or, for example, injection-moulded inside a plastic part, which is relevant for anti-counterfeiting applications. As potential future solutions, chipless RFID tags as well as light-based IoT tags have also been proposed.



Figure 11. UHF RFID yarn and a HF RFID tag.

Using simple and visible markers such as optical codes or insecure RFID tags leaves products open to forgery and wrongdoing. To tackle these problems, new solutions such as **chemical and forensic markers** are being developed. In these, identifiers are concealed in the molecular structure of a product. Several novel identification technologies have been introduced, including artificial DNA, various chemical (non-DNA) markers, as well as coating particles and microstructure particles. The origin of an organic product can also be identified by comparing the ratios of stable isotopes of elements in product samples against a specification.

The development stages for these solutions are varied: some are already established and available on the market, while others are still at the concept level. Many of these technologies are, however, relatively difficult to implement, making the identification process time-consuming, complex, or costly. However, these solutions have the unique advantage that they can be used to directly identify and authenticate raw materials such as wool or grain, instead of relying on identifiers attached to the packaging of the material.

For example, the identification system by FiberTrace (www.fibertrace.io) has been developed to track textiles throughout the production chain, and it uses nano-sized pigment particles of organic rare earth elements embedded in cellulose fibres. These fibres are mixed into any natural or synthetic fibre at the start of the production process, with no impact on texture or performance. After the fibres have been produced into a fabric, and the fabric further into a garment, the tracing fibres are still instantly readable using handheld, Bluetooth-connected readers, and the users can verify the entire history of the product in the supply chain.

3.2.3 Case: Blockchain and other distributed ledger technologies (DLT) provide a means for transparency and traceability

Blockchain (BC) is a distributed ledger that can be used to record and share information securely, and to enable online transactions. Information can be managed in a decentralised way and made available to those with access. For a

circular economy, blockchain has already proven to be useful in improving transparency and communication across value chains and in storing and sharing information securely, thus addressing a major barrier to achieving a circular economy. (Hedberg & Šipka, 2020)

From the perspective of a circular economy, blockchain technology provides interesting capabilities, including:

- Information transparency
- Reliability
- Smart contracts
- Micropayments / tokens

The blockchain-based ledger can be used to store circular economy data that can comprise the source of materials and products, actors involved, processes, energy consumption, and end of the life cycle. Additionally, when integrated with tracking devices (e.g., GPS), the blockchain enables life-cycle-long traceability of objects, materials, and products. These, together, can create the foundation for reusability, upcycling, recycling programmes, and circularity performance management. (Kouhizadeh, Zhu, & Sarkis, 2019)

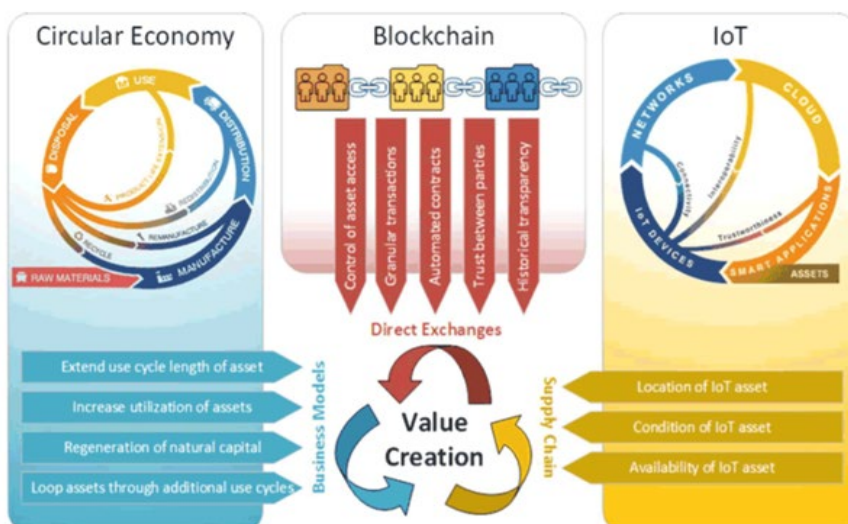

Figure 12. Interplay of value drivers created by blockchain, IoT, and the circular economy (Askoxylakis, Alexandris, & Demetriou, 2017).

Figure 12 depicts value creation in the circular economy enabled by blockchain and IoT. Blockchain is presented as a ledger for origin, a chain for logistics documents, as well as an enabler of granular micropayments in scale, enabling circular economy-related activities such as production optimization, marketplaces, and validating the quality of recycled material.

Table 6 presents some real-world blockchain applications in the circular economy field. These applications have been planned, piloted, or implemented by companies and, as shown, they widely utilize the blockchain capabilities of traceability, reliability, and smart execution. The applications are categorized using the ReSOLVE model (introduced by the Ellen MacArthur Foundation), which consists of six major strategic actions towards the circular business paradigm: Regenerate, Share, Optimise, Loop, Virtualise, and Exchange. Interestingly, blockchain-based applications can support all these actions.

At the EU level, the development of blockchain infrastructure is ongoing. The European Blockchain Services Infrastructure (EBSI), a joint initiative of the European Commission and the European Blockchain Partnership (EBP), aims at delivering EU-wide cross-border public services using blockchain technology (European Commission, 2020f). The EBSI will be implemented as a network of distributed nodes across Europe, leveraging an increasing number of applications focused on specific use cases. The first ones are:

- Notarisation
- Diplomas
- European Self-Sovereign Identity
- Trusted Data Sharing

In the EBSI Open Market Consultation Report (European Commission, 2020f), the Green Product Portfolio (Circular Product Tracking) use case, its requirements, and expected impact have also been assessed. In the report, Circular Product Tracking is still described as a demanding use case from the perspective of blockchain architecture. Significant R&D effort is needed to address, for example, issues related to scalability, data storage, and interoperability.

Table 6. Real-world circular economy-related blockchain applications planned, piloted, or implemented by companies. Adapted from (Kouhizadeh, Zhu, & Sarkis, 2019)

	Transparency / traceability	Security / reliability / immutability	Smart execution
REGENERATE	Decentralised energy/material management, renewable energy and materials (Toyota, Wien Energy) Digital Transactions (Toyota).	Solar energy trading on a transparent and secure peer-to-peer network (ABB).	Smart grids market for energy projects, e.g., smart gas (ABB).
SHARE		Enhanced trust and security through a new mobility ecosystem (e.g., autonomous vehicles) (Toyota).	Leverage business exchanges through smart contract – intermediate between two parties (Alibaba); Smart contracts – trigger automatic

	Transparency / traceability	Security / reliability / immutability	Smart execution
			payments and link them to the delivery systems (UPS); Using virtual currencies in the future for payment purposes (UPS).
OPTIMISE	Digital ad campaign buys and eliminate wasted spending and optimise ad buy (Toyota); Leverage big data – driving/testing data sharing; car/ride share transaction; usage-based insurance (Toyota); Global trade digitisation – container tracking, shipment traceability, shipping container condition information transparency (Maersk, UPS); Sustainability performance measurement traceability in livestock and agri-food products (BASF); The Blockchain in Transport Alliance (BiTA) defines standards frameworks for blockchains in the freight industry (UPS, FedEx, BNSF Railway).	Prevent fraud in digital advertising campaigns (Toyota); Improved product safety by assessing product authenticity (Walmart, Alibaba); Ensure trustworthiness of actions, freeze suspicious users' accounts, and minimise risks (Alibaba).	
LOOP	Reserve logistics activities traceability, e.g., history of returned / recalled cars, for repurpose decision making (Toyota); Monitor returns from multiple online channels (UPS).	Reliable information regarding the life cycle impact of products' provenance and leverage animal production value chain (BASF).	
VIRTUALISE	Transparency to the "entire life cycle of an	Replace paperwork with virtualised systems and	Ethereum-based smart contracts to store protocols with their

	Transparency / traceability	Security / reliability / immutability	Smart execution
	advertiser's media dollar flow" (Toyota); Food traceability between sources (i.e., farm) to stores in real time virtualisation on food conditions from the origins to the end sale point (Walmart, Bumble Bee Foods, BASF); Luxury goods traceability with dynamic image recognition system, laser marking, and QR codes (Alibaba); Upload and share product information, schedule shipments, manage sales, and facilitate marketing analytics (UPS).	enhanced reliability in documentation (Maersk); Provide blockchain service to help Chinese logistics and medical industry embed the secure transformation (Alibaba); Facilitate online business markets in a secure trusted manner (UPS); Tamper-resistant information sharing among supply chain parties addressing mislabelling and fraud issues in the seafood industry (Bumble Bee Foods); Track wellbore rock and fluid samples in a secure manner (BHP Billiton).	contractors, e.g., geologists and shipping companies (BHP Billiton).
EXCHANGE	A consortium formed by a major automaker to develop blockchain-based services in the automotive industry (Toyota, General Motors, BMW, Renault, Bosch, etc.); BiTA was formed to educate the freight industry for blockchain adoption (UPS, FedEx, BNSF Railway).	Leverage blockchains with RFID, QR codes, IoT, and similar sensors to prevent data falsification and increase reliability (Walmart, Alibaba, Bumble Bee Food).	

While Blockchain is a dominant technology and a well-known term, it must be noted that there are also other approaches to build distributed ledgers. For example, IOTA has developed from vast IoT-oriented research and is based on so-called DAG (Directed Acyclic Graph) technology. DAG allows immediate, free-of-charge transactions, fast operating speed, and scalability, which are all useful features, especially considering IoT systems.

The technologies described above enable data collection and data flow to support data analysis, modelling, and circular design decision making described in the next section.

3.3 Methods and frameworks for data analysis, modelling, and decision making in circular design

Susanna Horn, Hannu Ilvesniemi, Päivi Kivikytö-Reponen, Sami Majaniemi, Jukka-Pekka Ovaska, Eero Siivola, Jaana Sorvari, Teuvo Uusitalo

This report has already demonstrated different sources of existing data, innovative ways of collecting new data, and ways of distributing and managing this data. The data itself is usually not very valuable, due to often not being usable as such. The raw, original data can be used in generating simple visualizations and in computing statistical measures such as means. However, several more sophisticated methods exist for analysing, modelling, and making decisions using data. This section discusses these methods from the perspective of a circular economy.

Data analysis is typically understood as a process of using statistical techniques, predictive modelling, or prescriptive analysis (in the field of business analytics) with the goal of finding useful information and supporting decision-making. Data analysis can be combined with knowledge of materials science, process design, environmental sciences, social sciences, and economics. These data and model combinations provide more a reliable basis for analysis and may overcome the challenges related to data quality and issues related to the representativeness of the data sets. In addition to the quality of the data, the analysis and decision-making reliability are typically dependent on state-of-the-art algorithms, general understanding of the system under analysis, and sufficient computational capacity.

Decision-making to support the circular economy can have various forms and actions and may be carried out at several scales. Some of the decisions are needed at the macro level, to support the global circularity goals, while some other decisions are needed at the micro level to support a product system or a materials system through the life cycle. At the material level, and even at the microstructural level, decision-making is needed to support the design of recyclable chemistries, more durable materials, understanding of the impurities of secondary raw materials, and so on.

Circular design and Design for X (see below) are employed to influence and improve the circularity of materials and products. The combination of data analysis and science-based modelling supports circular design, and specific Design for X strategies, such as design out waste and pollution, design for repair, design for recycling and Safe and Sustainable by Design. The utilization of data analysis and science-based understanding provides new business opportunities and new business models to support sustainable development, for example, for zero waste strategies, using secondary raw materials, material lifetime extension, reuse, remanufacturing, and recycling.

Circular design requires the development of dedicated methodologies, it is not simply a collection of (historically) more or less unrelated assessment techniques. Circular design is recognized as a catalyst to move from linear operating and organizational models to a circular economy of linked operators. It can be defined

through a collection of key principles and strategies that designers should follow. Several design strategies are available:

- **Narrowing**, i.e., using fewer or less products, materials, energy, etc., over the life cycle of the system,
- **Slowing**, i.e., using products and materials longer,
- **Closing**, i.e., bringing waste back into the economic cycle,
- **Regenerating**, i.e., managing and sustaining natural ecosystem services and using renewable and nontoxic materials and energy, and
- **Informing**, i.e., using information technology to support the circular economy (Konietzko, Bocken & Hultink, 2020).

Circular design strategies should consider the systemic and hierarchical perspectives, which affect the selection of a proper circularity principle or Design for X method. Therefore, it is beneficial to divide circular design principles into hierarchical levels: product, business model, and ecosystem.

The scope of circular design principles operates in a hierarchical manner, covering various methods from the traditional product-level planning to macro (economy)-level planning. All these different levels require dedicated modelling methods detailed below.

3.3.1 Decision-making methods and tools

Life cycle assessment (LCA)

There is an increasing requirement on all levels of society to be able to assess the life cycle-wide sustainability impacts of different value chains, i.e., product systems. These assessments may impact on regulations, purchase decisions, consumer awareness or investment strategies, just to name a few.

As for environmental sustainability, life cycle assessment (LCA) has been developed to **quantify the environmental impacts that the product system causes in each process**. As such, LCA is defined as the compilation and evaluation of inputs, outputs, and potential environmental impacts of a product system throughout its life cycle and has been standardised by ISO. In practice, this means that each life cycle stage of a product or service (raw-material extraction, production, transportation, use, end-of-life processes) must be acknowledged and included in an LCA. The product system (a product or service) is followed from its cradle, where raw materials are extracted from natural resources, through production and use to its grave, the end-of-life processes (Baumann & Tillman, 2004). The environmental impact categories covered by the method include climate change, acidification, eutrophication, emissions of particulate matter, ozone depletion, ecotoxicity, human toxicity, and resource depletion (European Commission, 2013). The comprehensive scope of LCA is useful to avoid problem-

shifting between life cycle phases, regions, or environmental problems (Finnveden, 2009).

However, LCA is a time-consuming method, with high data requirements. Recently, LCA tools have started supporting functionalities for collaborative design and decision-making needed for circular design and Design for X problems, also to reduce the heavy process of data sourcing. The collaborative functionalities have been implemented in anticipation of companies' growing needs to adapt their sustainability management practices to better suit the forthcoming circular economy business models. In a circular economy, most materials need to circulate longer and cause less environmental impacts while product lifetimes are extended. Moreover, recyclability requirements and the use of waste streams in circular operations are subjects of keen interest at present. As companies' actions will affect the performance of other companies, circular operations and their collaborative sustainability design offers large potential for finding more optimal alternatives than previously.

The Network LCA¹ cloud service has been designed to serve circular economy operators to improve the use of company-related data without directly sharing it with any of the value network members. Instead, what is shared are the computational results generated from the data of the individual network partners related to their LCAs. As the shared results are aggregate results (e.g., total carbon footprint), no individual contributors can be identified from the publicly available information, which helps all network members to optimize their operations (e.g., material usage, chemical processes related to manufacturing). The network-level thinking can be generalized to other types of design, testing, and decision-making processes that use data, without sharing it.

Another generalization of the LCA methods (which, like Network LCA, does not require any changes to be made in the LCA method itself) is Online LCA². Just like Network LCA, Online LCA is a general tool that can be applied to almost any field of engineering and decision-making at the 'factory floor' level. Online LCA relies on the data obtained directly from the measurement sensors at the production site, such as the automation system. Real-time measurement data can be used as input for any simulation & computational models, which give the factory operators a real-time view of the sustainability indicators (e.g., carbon or water footprint, energy consumption). This extra information can be used by the operator to direct the production process into a more sustainable direction (one must, of course, choose from a set of likely conflicting indicators, with sustainability KPIs forming just one subset of decision variables). Nevertheless, the information will be available for decision-making at a much higher frequency than in the 'traditional' life-cycle assessment, which is possibly carried out just once, or once each time legislation changes.

¹ Public Network LCA demo tool (requires registration): <https://modellingfactory.org/services#lca>

² Online LCA information: <https://modellingfactory.org/services#online>

Social LCA (s-LCA)

Sustainability does not limit itself to mere environmental considerations but should include an assessment of social sustainability (and economic as well, as discussed in the following section). Social LCA (s-LCA) is an extension of LCA and aims to complement the assessment with social and socio-economic aspects of products and their potential positive and negative impacts along their life cycle. (UNEP, 2009) As in LCA, the life cycle encompasses the extraction and processing of raw materials, manufacturing, distribution, use, re-use, maintenance, recycling, and final disposal. In comparison to LCA, a clear difference lies in the fact that inventory data and impact assessment are specified in relation to different defined stakeholders and are locally bound. In s-LCA, stakeholder involvement/participation is also emphasized. When carrying out an s-LCA, the definition of subcategories is the basis of an assessment, because they are the items on which justification of inclusion or exclusion needs to be provided. The subcategories are socially significant themes or attributes and are detailed by Benoît-Norris et al. (2011). Subcategories are classified according to stakeholder and impact categories and are assessed using inventory indicators, measured with a unit of measurement. While traditional LCA focusing on environmental impacts is already standardized, s-LCA is a more novel methodology and a consensus on a systematic and standardized procedure for conducting the assessment has not yet been achieved (Iofrida, Strano, Gulisano, & Luca, 2018; Di Cesare, Silveri, & Sala, 2018). Given the immaturity of the field, depending on the specific methods chosen, there is considerably more room for interpretation of the results than with LCA. Also, some of the currently used definitions may not be compatible with all the practices followed in the more quantified older fields. Many of the quantitative methods developed elsewhere can also be applied as part of s-LCA studies (e.g., cost-benefit, risk, and scenario analyses). Part of the challenge of s-LCA is dealing with the multitude of dimensions in which social impacts can be studied (e.g., legal compliance, international relations, socio-cultural effects).

As such, many of the s-LCA principles are highly compatible with the general idea of a circular economy, such as the focus on being able to evaluate sustainability over entire value chains (many linked operators). It is also possible to integrate some of the more quantitative s-LCA models with other types of assessment models (see the sections on LCA and LCC above). To do this, social sustainability should be defined in a narrow sense and, for instance, restricted to the evaluation of macro-economic indicators such as taxation and income distribution-related measures, or labour force evolution.

Life cycle costing (LCC) and environmental life cycle costing (eLCC)

Life cycle costing is a process to determine the sum of all expenses associated with a product, process, sub-process, or project, including acquisition and all associated costs, operation and maintenance, refurbishment, and retirement costs. The IEC

standard on Life Cycle Costing (IEC 60300-3-3:2017, 2017) defines LCC as the process of performing an economic analysis to assess the cost of an item over a portion, or all, of its life cycle to make decisions that will minimize the total cost of ownership while still meeting stakeholder requirements.

A typical case for LCC calculation is a decision-making situation aiming to select an optimal alternative among different options. By considering life cycle costs, decision makers have a better opportunity to optimize the total cost of ownership and achieve better profitability in the long term. The costs over the lifetime of the solution are discounted to current values. LCC is typically based on the cost breakdown structure, which is a representation of costs related to the case in question and divides a rather abstract life cycle cost into more concrete and thus more easily estimated cost elements. The hierarchical way to define cost structure promotes the recognition of all relevant cost elements. The breakdown of the cost elements into lower cost items is needed to be able to make the calculations.

Within the context of sustainability assessments, there have been developments to better consider the way the so-called hidden, social, or external costs are dealt with in the method of environmental life cycle costing (eLCC) (Klöpffer, 2003). The eLCC Code of Practice (Swarr, et al., 2009) formulated a description of the method in such a way that instead of having to monetarize external impacts, such as pollution, the subsequent assessment of environmental impacts (LCA) and economic impacts (eLCC), and potentially also social impacts (s-LCA), would make all different impacts of the product system transparent (Swarr, et al., 2011). The parallel LCA and eLCC would rectify the problem of double counting any impacts (having external costs expressed both in monetary units and in environmental units).

Risk assessment

Within the LCA-LCC methodologies described above, the so-called constant environmental impacts are mainly accounted for. However, in various industry sectors, there are also considerable safety issues and environmental risks that need to be factored in the decisions.

There are three principles to follow when creating a product:

- **Safety in design** covers the evaluation of safety during the original product design. This phase should include the designation of the product life cycle (see above for LCA). The methods to limit the risks of a product below the tolerable risk level should also be considered.
- **Safety in production** refers to the manifestation of design principles and the hazard analysis into the establishment of the actual product and addresses the steps necessary to move basic principles along the supply chain, from design to manufacturing.
- **Safety in the marketplace** covers the responsibilities of the distributor, provider, or vendor in ensuring that the product order meets the safety

requirements. Ensuring safety in the marketplace means that the incidents, warranty returns, and all other product hazards that were missed in the earlier assessments will verify conformance and determine the need for continuous improvement.

Risk comprises the severity of a consequence/harm and the probability of its occurrence. Risk assessment (RA) is a procedure for determining the risks, i.e., potential harm, and it identifies the severity of hazards to determine whether the risk level is high or low as compared with the level defined by the risk manager. In general, risk can refer to risks to human health, the environment, or society. Thus, risk assessment can focus on ecotoxicological and toxicological risks arising from harmful substances, psychological and social/societal risks, and economic risks. RA can be either a qualitative or quantitative process, and the latter can be either deterministic or probabilistic.

In case of products, RA is first performed in the design stage and again over time along with any changes in the process or product specifications or more accurate or increased data. Therefore, there should be continuous data flow between the different product phases (Figure 13). Risk assessment differs from LCA by considering the whole event chain from the source via exposure to the effects on the recipient. While providing the design phase with more specific information on the risks related to harmful substances, RA can complement LCA, which addresses these only superficially. Also, unlike in LCA, probability is an inherent property. By considering exposure scenarios, RA also provides more realistic and application-specific information on the hazards. This means that scenarios for how the product could be manufactured and what hazards could occur need to be developed in the first place.

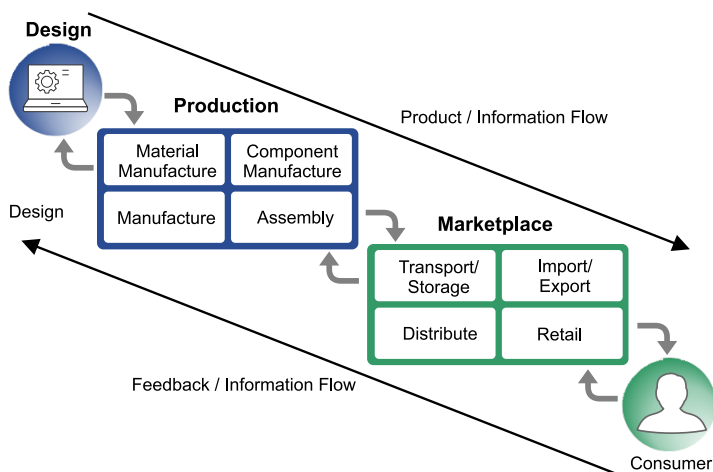

Figure 13. Information flows related to product development (International Organization for Standardization, 2013).

The international standard ISO 10377:2013 (“Consumer product safety – Guidelines for suppliers”) includes practical guidance about product risk assessment. It considers safety in design, production, and in the marketplace and addresses areas such as hazard identification, foreseeable use and misuse, exposure analysis, developing injury scenarios, and evaluation of the severity and probability of injury. It excludes issues such as worker safety, protection of the environment (addressed in the 13.020 series of standards), or social and ethical issues. The guidance also describes an iterative process of risk assessment that is repeated as risk reduction measures are established (Figure 14). Although the standard is meant for consumer products, it can also be adopted in the production of other items.

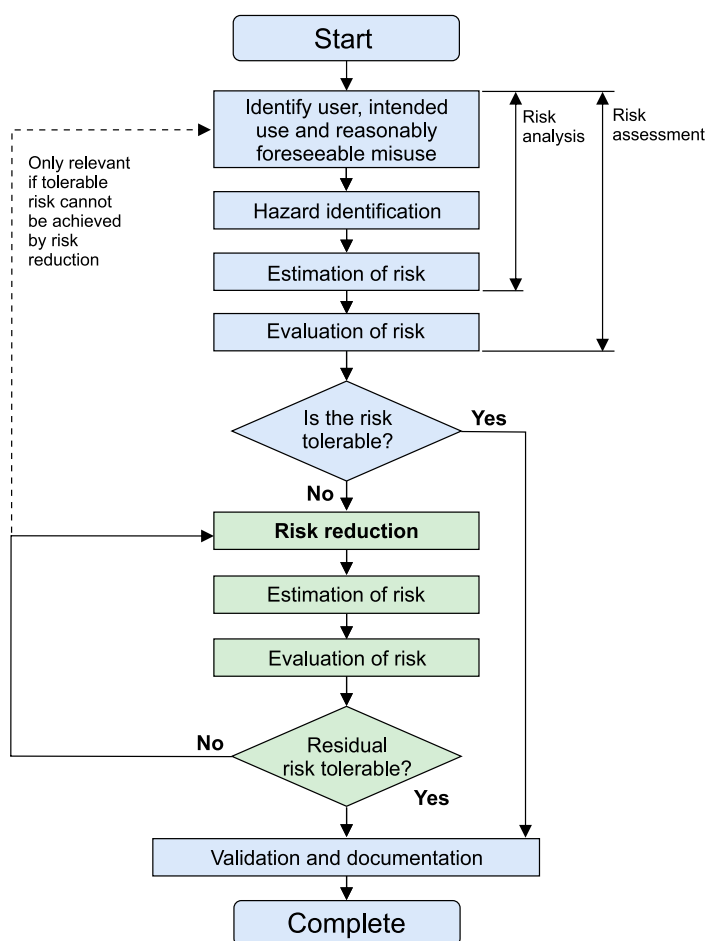

Figure 14. The iterative risk assessment process (International Organization for Standardization and International Electrotechnical Commission, 2014).

Multi-criteria decision making

Multi-Criteria Decision Making (MCDM) or Multi-Criteria (Decision) Analysis (MC(D)A) refers to a process that enables the solving of complex decision problems. MCDM refers to the evaluation of several decision alternatives by considering different contributing factors (decision criteria) involved in decision-making, such as environmental performance, costs, social aspects, and societal factors. MCDM applies different processes, which cover various methods based on different models (Figure 15). The common property of all these methods is that they enable the combining of decision criteria that may have different dimensions and units. MCDM methods also allow the decision-maker to account for the importance of the contributing factors in the decision-making by assigning weights, i.e., numerical multipliers, which imply their importance in relation to each other; by rating each factor or objective against other factors and objectives; or by ranking the decision alternatives. Therefore, MCDM tools also provide a decision maker with a possibility to involve different stakeholders in the decision process, find their preferences, and identify the most optimal, compromise solution.

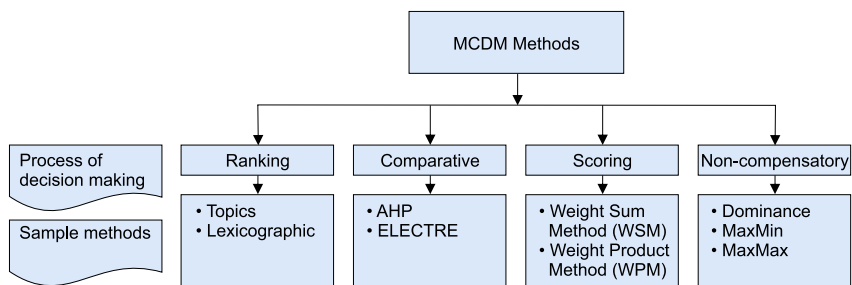

Figure 15. Different MCDM processes and examples of their most common methods (Jafaryeganeh, Ventura, & Guedes Soares, 2020). TOPSIS = Technique for Order Preferences by Similarity to an Ideal Solution; AHP = Analytical Hierarchy Procedure, ELECTRE = ELimination Et Choix Traduisant la REalite.

Different MCDM methods have been used in diverse contexts, such as in the planning of energy systems, logistics, and water resources management, in government policy development, in product design, in the selection of remediation and restoration methods, and in city planning, among others (Kumar, et al., 2017; Linkov, et al., 2006). Independent of the method chosen, the MCDM procedure should start with a clear definition of the decision problem to be solved and alternative solutions, followed by the definition of decision criteria (Figure 16).

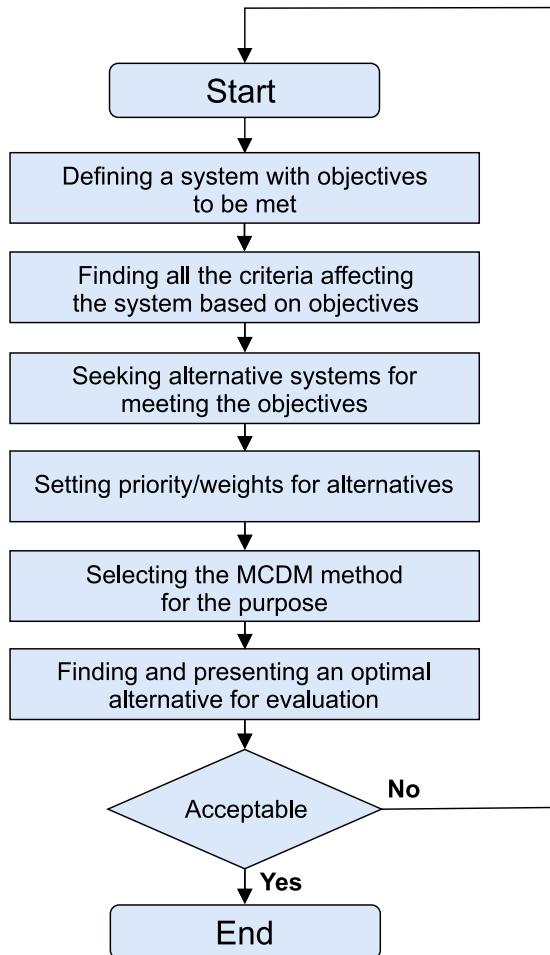

Figure 16. Generic works steps of a MCDM procedure (Kumar, et al., 2017).

Each MCDM has its strengths and weaknesses, and while some generic guidance and decision charts are available (e.g., Sabaei, Erkoyuncu, & Roy (2015), the choice of the method is ultimately subjective. Figure 17 presents an example of an MCDM procedure developed for the identification of the best circular strategies in product design. Particularly quantitative MCDM methods generally require large amount of data that may not be available in the design phase. This can limit their usability and reduce the reliability of the results.

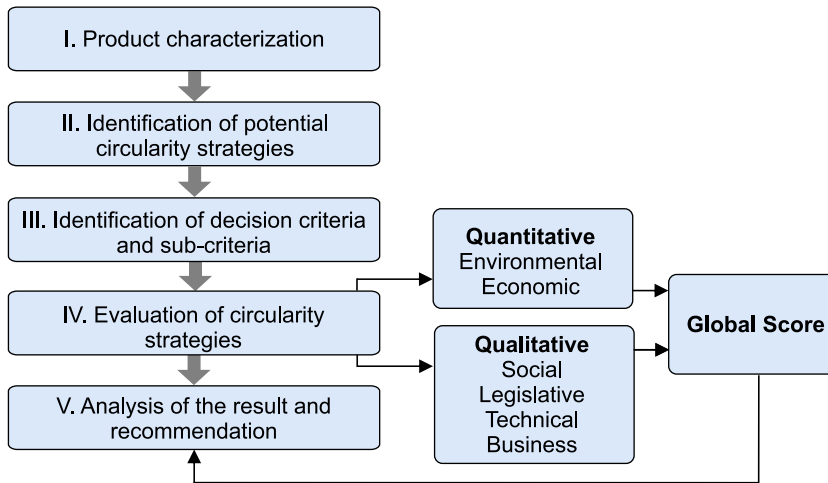

Figure 17. Example of an MCDM procedure for selecting circular solutions in product design and the quantitative and qualitative decision criteria included in it (Alamerew, Kambanou, Sakao, & Brissaud, 2020)

Integrated computational materials engineering (ICME)

A fully integrated Design for circularity / eco-design / Design for X framework should also enable the use of ICME (Integrated computational materials engineering) simulation models. ICME has traditionally been associated with (microscopic) product-wise design, but on a methodology level, there is nothing that prevents it from also being applied to larger scale applications. ICME models are typically multi-domain (multi-physics) models, which develop the hierarchical (multi-scale) approach from the point of view of an isolated application.

In addition to their quantitiveness (owing to the physics-based nature of the models), ICME category simulations provide important information about the product and its materials performance under realistic use conditions. These results can be utilized in LCC and LCA type assessments, as well as in systemic-level sustainable development descriptions, to provide estimates of the lifetimes of different products (e.g., how fast materials wear out, when certain types of functionalities are lost), among other uses.

ICME category models are typically very heavy computationally, which means that faster-to-compute (surrogate) versions typically need to be developed for integration purposes with other types of assessment models related to circular design. Again, this task is in no way trivial and requires dedicated resources and knowledge.

Design for Circular Economy & Design for X (DfX)

The technologies and analysis frameworks described above support the actual design work for a circular economy. The importance of design for circular economy is acknowledged, for example from the sustainability perspective, even if the design phase may determine as much as 80% of the environmental impact of a product (European Commission, 2014). Typically, circular design strategies include 'narrowing', 'slowing', and 'closing' the material loops (Bocken, de Pauw, Bakker, & van der Grinten, 2016). These are the strategies that can be the basis of business models and service design. Furthermore, actual material and product design should support the holistic circular strategies and circular business models through suitable Design for X approaches.

Circular design targets fitting the materials and products into circular systems. Therefore, understanding the whole life cycle of the materials and products is essential. It is sometimes forgotten that circular systems require both circular materials and circular products, and the design of both of these is therefore important. However, they are individual processes and typically designed separately. First, materials are designed and then materials available in the market are selected in the product design phase. However, there are exceptions. For example, additive manufacturing methods enable simultaneous material design and product (component) design. The design process typically starts by setting goals and requirements and selecting potential approaches for achieving these goals. The work continues with typical design process steps that include the following:

- create understanding of the system
- create ideas
- create concepts
- select the concepts to be developed further
- design the details
- test or pilot
- launch to the market
- lifetime support
- design for recycling.

The earlier in the process the circular design decisions are made, the greater are the possibilities to impact on the sustainability of materials and products.

Circular design concepts and methods can be applied to both material and product design. However, there seems to be more literature about circular product design than circular material design concepts. The key product design concepts and terms of the 'design for circular economy' have been reviewed by den Hollander et al. (2017), who stated that circular product design encompasses both design for product integrity and design for recycling. Product integrity covers longer lifetime strategies such as design for emotional and physical durability, design for maintenance and upgrading, design for repair, design for refurbishment, and design for remanufacturing (den Hollander, Bakker, & Hultink, 2017). Design for circular economy can also be broken down into other DfX strategies, such as in terms of R

strategies according to the R9 framework (Kirchherr, Reike, & Hekkert, 2017). For product integrity, the R9 framework includes design for reuse, repair, refurbish, remanufacture, and repurpose (Figure 18).

In addition to the lifetime extension strategies included in the R9 framework, design for a long lifetime can also be based on other product integrity strategies, including design for attachment and trust, design for durability, design for standardization and compatibility, design for ease of maintenance and repair, design for adaptability and upgradability, and design for dis- and reassembly (Figure 19). (Bakker, den Hollander, van Hinte, & Zijlstra, 2014)

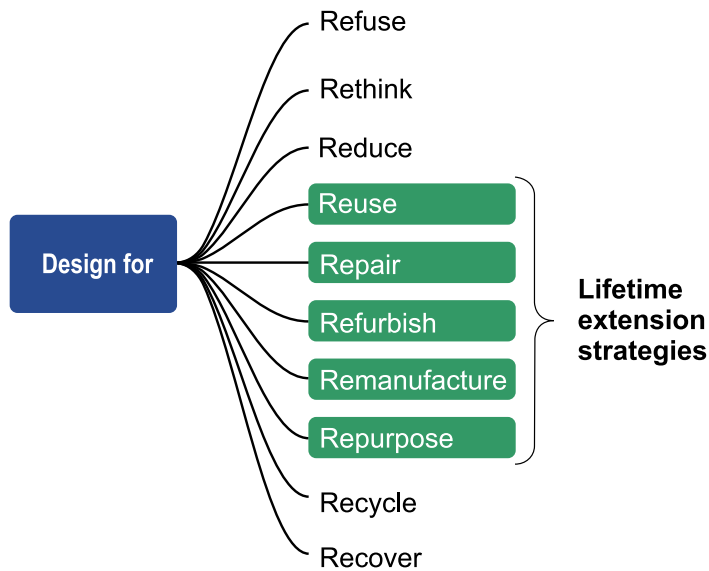

Figure 18. Design for R shows the different design aims to support the Design for Multiple Use Cycles and Design for Recovery.

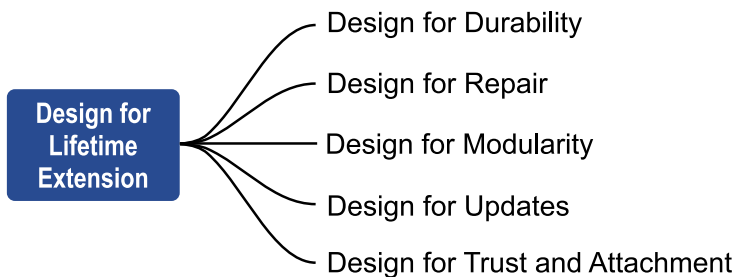

Figure 19. Design for lifetime extension. Modified from Bakker, den Hollander, van Hinte, & Zijlstra (2014).

As described above, a holistic and systemic view needs to be taken to arrive at truly circular economy solutions. Design for X strategies thus need to be selected that fulfil this overall goal, as illustrated by the example of designing products for durability. In a physical sense, durability is a material property that impacts on product reliability in use and a longer potential lifetime (Bakker, den Hollander, van Hinte, & Zijlstra, 2014). Design for physical durability thus targets optimal mechanical, chemical, and thermal properties expected from a product. Concerning physical durability, the product performance is improved with 'durable' materials, for example, against aging, fatigue, wear, or corrosion. However, design for durability can lead to more durable materials and components (e.g., composite or complex multilayer materials) that are difficult or even impossible to recycle in current facilities. Attempts to increase the durability of materials can also increase the need for critical materials or hazardous substances. Therefore, several DfX strategies should preferably be considered, not aiming solely at one DfX target, but combining selected DfX strategies in practical design exercises.

Machine learning

Machine learning (ML) is a form of data analysis in which existing data is used to automatically train a computer to perform specific tasks. The biggest strength of machine learning algorithms as compared to more traditional data analysis methods is self-training: no-one needs to explicitly tell the computer what to do. This allows machine learning algorithms to rapidly and easily utilize large amounts of data. The downside of these methods is that without the context and knowledge that humans usually have when building models for data analysis, machine learning algorithms are usually considered to be rather data heavy. That is, they need lots of data for the outcome of the self-training to be useful in practice. A good and easy to understand book on the basics of modern machine learning algorithms is available at <https://www.deeplearningbook.org/> (Goodfellow, Bengio, & Courville, 2016).

Machine learning methods can help utilize and collect data that is needed in all phases of the life cycle of a product based on circular economy. Not much research and work can be found on combining circular economy and machine learning. However, there are many review articles hypothesizing about the uses of machine learning in the context of a circular economy (Pagoropoulos, Pigosso, & McAlloone, 2017; D'Amato, et al., 2017; Malahat & Happonen, 2020). The existing use cases have proved that machine learning can help in managing the supply chain (Wang & Yuming, 2020) and optimizing resource use (Khayyam, et al., 2021; Magazzino, Mele, Schneider, & Sarkodie, 2021). In addition to the ML solutions applied solely in the circular economy context, there are more use cases of reducing running costs with resource optimization (Wang, et al., 2018) and predictive maintenance (Wu, Gebraeel, Lawley, & Yih, 2007). These solutions can be applied to any product, not just those classified as circular economy.

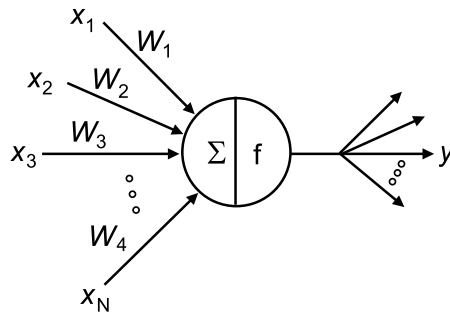

Figure 20. A single computational unit in a neural network. The output is computed as $y = f(\sum_{i=1}^N w_i x_i)$, where x_i are the inputs of the neuron, w_i are the weights of each input, $f(\cdot)$ is an activation function, and y is the output of the neuron that can be split or copied to be an input of another neuron. A very common activation function is rectified linear (relu), $f(x) = \max(0, x)$.

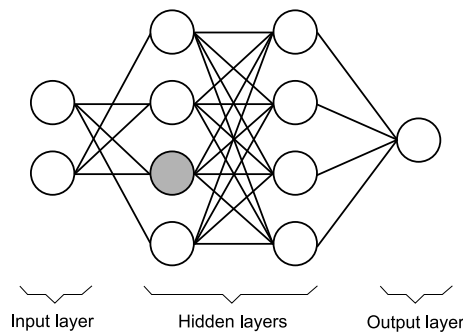

Figure 21. An illustration of a simple neural network with 2-dimensional input and one-dimensional output. In this case, there are two hidden layers with four neurons in each. As an example, the output of the third neuron in the first hidden layer (coloured grey) can be computed as $y_{13} = f(\sum_{i=1}^2 w_{i3} x_i)$.

Arguably the most prominent and versatile ML technique is neural networks. Algorithms based on neural networks can be used as self-learning black boxes that do not necessarily require deep understanding of mathematics or other ML approaches. Neural networks are computational structures inspired by biological brains. Similarly, they consist of computing units, neurons, that are connected to one another. By connecting multiple neurons to one another with tuneable weights, it is possible to generate very versatile and flexible algorithms that can be taught to solve various tasks. See Figure 20 for an illustration of a neuron and Figure 21 for an illustration of a simple neural network. The learning happens by iteratively changing the connecting weights so that a predefined loss function of the input data is minimized. The iterative tuning happens by computing the gradients of the loss

function value with respect to the weights of the neural network and moving each weight to the direction of the negative gradient. Recent software packages can compute the required gradients automatically without the user having to understand complex matrix algebra. In addition to the ease of use, another major reason for the popularity of neural networks is their scalability as a function of available data. Modern graphics processing units (GPUs) are specialized at rapidly computing matrix algebra, which makes training neural networks fast. Good learning material for further details can be found in (Goodfellow, Bengio, & Courville, 2016). In the circular economy context, neural networks have been applied to waste prediction (Qdais, Hani, & Shatnawi, 2010; Magazzino, Mele, Schneider, & Sarkodie, 2021) and supply chain management (Wang & Yuming, 2020). In addition to this, neural networks are a popular approach in predictive maintenance (Wu, Gebraeel, Lawley, & Yih, 2007; Kanawaday & Sane, 2017; Rivas, et al., 2019).

Although neural networks play a significant role in a large part of new machine learning-related research and product development, there are also other prominent technologies. Bayesian networks are a widely applied machine learning approach for building models of variables (e.g., raw materials and products) and their connections. Mathematically, they are directed acyclic graphs that form hierarchical probabilistic models. The nodes of the graph represent the variables of interest by probability distributions and the edges of the graph represent the connections of the variables. Bayesian networks can be used to build static and dynamic models, and tools (Çambaşı, Kuru, Amasyalı, & Tahar, 2019) and tutorials (Heckerman, 2008) are available. In the circular economy context, Bayesian networks have been used to analyse the stability of a recycling system (Wang, 2016) and to study behavioural aspects of systems based on circular economy (Bakshan, Srour, Chehab, El-Fadel, & Karaziwan, 2017). Another, more recent, machine learning-based data management method is differential privacy (Dwork, Rothblum, & Vadhan, 2010). Differential privacy is an approach for sharing data while guaranteeing the privacy of the individuals sharing data. Differential privacy allows different stakeholders to share their data with one another and guarantee that the data cannot be misused. Differential privacy has been used to share data from smartphones (Nguyễn, 2016) and share health-related data (Choudhury, 2019), among other applications.

3.3.2 Circular business models and financial decision-making

As we have seen in previous sections, many tools, data, and analysis frameworks can be used in assessing the social and environmental sustainability of new circular products and services. However, even the most sustainable products also need to be economically viable, otherwise they will not last long in the marketplace. This is why we now turn our focus to circular business models and financial decision-making. Circular business models have been touched upon a few times throughout the handbook in the context of building circular data flows or designing circular products. This section discusses the concept of circular business models more thoroughly and introduces a few simple metrics and methods that managers, designers, and entrepreneurs can use when making financial decisions about new

circular solutions. Understanding these aspects of sustainability is not only important for making decisions about the design of new circular products and services, but they can also help secure funding from investors, creditors, or other sources by demonstrating that a new idea is economically sound. This is not restricted to private enterprises, but non-profit organizations and social enterprises also need to cover their costs of operation, pay their employees, and invest in growth so they can expand their impact.

Circular business models

A business model defines how a company creates, delivers, and captures value. It outlines what services or products a company offers to its customers, how it promises to deliver these services, and how the company plans to generate revenue from the service. How a company creates and delivers value is also called a *value proposition*, and how a company captures value is often called a *revenue model* or a *value capture logic*. These two sides of the same coin are enabled by all the other parts of a business system, including partnerships, supply chains, logistics, manufacturing, service operations, marketing, sales, and delivery. A business model can be written down and used for communicating these elements and their interactions to internal and external stakeholders, but a business model can also be a source of innovation. A classic example of business model innovation is Southwest Airlines, an American airline company that redesigned its business model by eliminating unnecessary and expensive elements from its value proposition and by implementing operational efficiencies that further reduced its operating costs. The changes allowed it to introduce cheaper tickets than any of its competitors could offer and serve a new group of price-sensitive customers that were previously unserved by other airlines.

A circular business model is essentially the same concept as a conventional business model, but with the added dimension of narrowing, slowing, and closing resource and energy loops (Bocken, de Pauw, Bakker, & van der Grinten, 2016; Bocken & Antikainen, 2018; Geissdoerfer, Morioka, de Carvalho, & Evans, 2018; Bocken & Ritala, 2021). In addition to outlining how a company creates, delivers, and captures value, a circular business model details how the company integrates the logic of circular economy into its operations. This can happen in various ways, and many different frameworks for circular business models have been introduced over the past few years. In this handbook, we use the circular business model strategy framework introduced by Nancy Bocken and Paavo Ritala (2021). The framework has two dimensions: 1) Resource strategy and 2) Innovation strategy.

		Resource strategy		
		Narrowing loops	Slowing loops	Closing loops
Innovation strategy	Open	<p><i>Open-narrowing</i></p> <p>Value proposition (example): Reduce waste and resources in design and production processes</p> <p>Value creation and delivery: Reduce cost and negative impact through new technologies and processes in collaboration with suppliers, customers and others</p> <p>Value capture logic: Save cost and resources</p> <p>Case examples: Industry collaboration on cleaner refrigeration technology; Sony and Samsung collaboration on LCD efficiency</p>	<p><i>Open-slowng</i></p> <p>Value proposition (example): Reuse resources to broaden the offerings to the customer (e.g. vintage, second-hand)</p> <p>Value creation and delivery: Create value by connecting internal and external resource flows via generative models</p> <p>Value capture logic: Increase the number of transactions in an ecosystems via reuse of products</p> <p>Case examples: H&M - Sellpy collaboration on second-hand clothes market; iFixit repair platform; ResQ Club excess food sales model</p>	<p><i>Open-closing</i></p> <p>Value proposition (example): A circular offering which involves lower environmental footprint and resource burden</p> <p>Value creation and delivery: Combine resource flows from external ecosystem into customer offerings</p> <p>Value capture logic: Lower the cost of resources used in customer offerings, improve brand and corporate image</p> <p>Case examples: Interface Networks for "circular carpets" with ZSL, Aquafi and fishery communities; JLR and Novelis closing the aluminum loop</p>
	Closed	<p><i>Closed-narrowing</i></p> <p>Value proposition (example): Reduce waste and resources in design and production processes</p> <p>Value creation and delivery: Reduce cost and negative impact through internal technology, process and design innovations</p> <p>Value capture logic: Save cost and resources</p> <p>Case examples: Companies like Apple minimising packaging and using recycled materials; McDonald's "fried for fuel"</p>	<p><i>Closed-slowng</i></p> <p>Value proposition (example): High quality products with high customer value</p> <p>Value creation and delivery: Long lasting design, repair services; create more value from less resources</p> <p>Value capture logic: Price premium through achieving quality leadership and customer loyalty; create value from same product multiple times</p> <p>Case examples: Long-life warranties; hotel linen rental services focused on product longevity</p>	<p><i>Closed-closing</i></p> <p>Value proposition (example): Connect with customers by using, recovering, and maintaining post-consumer materials</p> <p>Value creation and delivery: Increase customer retention and repurchases via take-back plans</p> <p>Value capture logic: Resource efficiency, improve brand and reputation, reduce cost for materials</p> <p>Case examples: Take back, rental and lease models to recover the company's own materials such as MUD Jeans Lease and Phillips pay per lux</p>

Figure 22. Circular business model strategy framework. Source: (Bocken & Ritala, 2021). Six ways to build circular business models. Journal of Business Strategy, Vol. ahead-of-print No. ahead-of-print.

- Firstly, *resource strategy* refers to the three environmental goals of the circular economy, as proposed by Bocken et al. (2016): narrowing, slowing, and closing resource loops.
- *Narrowing resource loops* is about using fewer resources throughout a company's value chain. This is achieved by improving the efficiency of operations, reducing material waste, and removing redundancies, all of which are also desirable goals in the traditional linear economy.
- *Slowing resource loops* is about extending the lifetime of products so that they remain in use for as long as possible. Product quality and durability are the watchwords of this strategy, but it is also crucial to provide maintenance and repair services. Another key practice for slowing resource loops is to provide a service or to sell an outcome instead of a product, which makes it even easier to maintain and increase the lifetime of products and assets.

- *Closing resource loops* is about making sure that products and assets do not end up as waste at the end of their lifetime. Recycling is only one part of closing resource loops, as recycling usually downgrades materials and destroys some of the value and energy embedded in products. Upcycling is the opposite of recycling, with new value being added to the product as part of its repurposing. A product can also be reused for its original purpose after necessary repairs and refurbishments.

Secondly, *innovation strategy* dictates whether the circular business model involves open or closed innovation. A *closed innovation strategy* involves introducing new practices only within the boundaries of the firm, for example establishing take-back schemes that allow customers to return their products for reuse, recycling, or upcycling. In contrast, an *open innovation strategy* involves building the business model in collaboration with partners, customers, or other external stakeholders. Taken together, the two dimensions result in six different circular business model archetypes: *Open-narrowing*, *open-slowness*, *open-closing*, and *closed-narrowing*, *closed-slowness*, *closed-closing*. Figure 22 provides more details about each type.

Circular business models present many benefits and opportunities to companies. Perhaps the most obvious benefit is that circular business models help reduce waste and improve material efficiency, which usually translates to reduced costs. A more indirect benefit is that designing more long-lasting products can also improve customer satisfaction and help develop deep customer relationships. For example, Touchpoint – a Finnish workwear company – designs its workwear for durability and recycling and allows its customers to return their products for recycling once they become worn and damaged. Touchpoint also provides its customers with environmental KPIs that help customers keep track of their own environmental footprint. The overall service is a turn-key solution that allows customers to focus on their own business rather than spend time thinking about workwear. Providing more holistic services or even launching product-service systems may work especially well in capital-intensive industries such as industrial machinery and tools. For example, Hilti, Caterpillar, and Kaeser Compressors have developed fleet management and leasing services that either retain the ownership of the product with the manufacturer or optimize the fleet of machines and tools for the customer by removing redundancies and overlapping resources. These services reduce resource consumption, help customers save money, and are good for business. Launching new leasing services or product-service systems may also lead to collaboration between new ecosystem partners, which can be a source of innovation and competitive advantage in its own right (Rajala, et al., 2018).

In addition to reducing costs and helping companies innovate on existing operations, circular business models can help companies find completely new sources of revenue. For example, Varusteleka and Pure Waste Textiles are two Finnish clothing companies that do business by tapping into previously unused raw materials. Varusteleka is Europe's largest seller of surplus military clothing, and has also established a take-back scheme for its own goods, which further increases the clothes' lifetime. Pure Waste Textiles buys pre-consumer surplus textiles from

textile factories in India and turns them into yarns, textiles, and clothes. Both companies have seen fast growth and increasing profits since their foundation. A circular business model can also reduce a company's dependency on certain materials and mitigate the risk of material price shocks (Ghisellini, Cialani, & Ulgiati, 2016). As we have seen during the COVID19 pandemic, global supply chains are vulnerable to disruptions that can result in long supply bottlenecks. Using recycled materials from more local sources diversifies a company's materials base and helps reduce these supply chain risks. Finally, being a sustainability forerunner helps companies reduce regulatory risks and adapt faster to changes in the business environment. For example, in 2021, the EU commission put forth plans for the world's first carbon border tax for steel, aluminium, cement, fertilizers, and electricity. The tax will put a carbon price on imports and therefore increase the cost of many products and product parts throughout the supply chain in these industries. The increasing price of CO₂ emissions is both a risk to be avoided and an opportunity to create a competitive advantage by adopting a low-carbon circular business model.

Building a circular business model or circular products also involves many challenges. The biggest and most obvious challenge is that a circular business model may require fundamental changes to many, if not all, aspects of a company's business operations. Depending on the company's industry and current business model, building a circular business may involve anything from establishing reverse logistics and product take-back schemes to developing product-service systems or industrial symbioses. For example, replacing a product with a leasing service will likely require developing a new service model and maintenance operations to facilitate leasing, as well as arranging the recycling/upcycling of the rented products. Even when a circular business model builds on a company's existing competencies, the new model may involve many changes to the company's day-to-day operations. Creating closed material loops can make managing material flows and supply chains drastically more complicated, as the whole life cycle of the materials needs to be considered. Circular business models also increase interdependencies between companies. For example, creating closed resource loops can make a business more reliant on the outputs of other companies and often necessitates close cooperation across the company's entire supply chain (Lopes de Sousa Jabbour, et al., 2019). Circular business models are also closely connected with supply chain management, as reconfiguring a company's supply chain can affect its business model, and vice versa (Bocken, de Pauw, Bakker, & van der Grinten, 2016; De Angelis, Howard, & Miemczyk, 2018). For example, choosing new material sources and supply chain partners can change the company's cost structure and may therefore require changes to product pricing and to the customer value proposition. Conversely, launching a new product rental service may necessitate changes in existing products, which in turn may require new supply chain partners to facilitate these changes. These interdependencies add another layer of complexity and risk to circular business models, which managers and decision-makers should consider when adopting circular practices.

Finally, it is necessary to recognize that adopting a circular business model may not always lead to increased revenue or reduced costs. Firstly, all entrepreneurs, business managers, engineers, and designers know that ideas are worthless without proper execution. Like any other business development or change program, adopting a circular business model needs careful planning and execution, especially because of the complexities and interdependencies discussed above. More importantly, managers and decision-makers need to consider the real possibility that being a circular economy forerunner may sometimes improve environmental and social sustainability, but not profitability. The environmental and social sustainability improvements related to circular business models are a common good, in the same way that CO₂ emissions and waste are a common cost. Because of this, the profitability of circular business models is not always solely dependent on the decisions and actions of individuals, but may require new taxes, regulation, or other incentives to level the playing field for more sustainable alternatives. For example, introducing more mechanisms for pricing CO₂ emissions may be a necessary enabler that makes circular business models and sustainable solutions truly viable. Business decision-makers should therefore take stock of all the potential benefits that adopting different circular business models involve and weigh them against the costs. Decisions about how, when, and which circular business model to adopt can be a complex process that takes time. There is no silver bullet to making a perfect decision, so it is important to plan carefully, do experiments, and have different options available.

Financial decision-making tools

The role of data and good decision-making tools can be crucial when adopting a circular business model. As discussed in earlier chapters, assessing the environmental, social, and monetary impacts of products along their whole life cycle is an important step when comparing the benefits and risks of different alternatives. These tools can be used as input for other financial decision-making techniques that focus purely on the profitability of different business models and products. It might not always be possible to analyse every little detail of a business model before implementation, but the costs and future revenues can be roughly estimated. Furthermore, creating a circular business model will often require investments into new production techniques, product designs, supply chains, or personnel, depending on the nature of the business. In this section, we will introduce a few simple techniques for evaluating the benefits and costs of such investments. This is not a comprehensive summary of all the available tools and models. Instead, we will introduce the three most widely adopted and simple to use techniques that you can start using immediately. They are not specific to the circular economy, but they are fully applicable to the context of circular business models when evaluating their benefits in terms of cash flow and profits.

Return on investment (ROI)

Return on investment (ROI) is one of the most widely used financial planning and investment tools for assessing the financial performance of different investments and projects. Simply put, ROI is a method that gives the profit of an investment as a percentage, whether the investment is the launch of a new business venture, purchasing new capital equipment, building a new production facility, or designing a new product. ROI can also be used for estimating future profits for a planned investment and can therefore be a good starting point for deciding between alternative circular business models or related projects. For example, if a manager is deciding between a new circular supply chain project or a new circular product launch, he/she can calculate the ROI-% of both investments and compare the two. It is also useful for finding low-hanging fruits where small investments can lead to greater future profits. The return on an investment that has already been made is called actual ROI and the return on a future investment is called estimated or anticipated ROI.

For more information and the full formula: <https://online.hbs.edu/blog/post/how-to-calculate-roi-for-a-project>

Payback period

The payback period method is one of the simplest methods for comparing different investment alternatives and is often the starting point for analysing a potential investment. As the name suggests, the method involves calculating the time it takes for an investment to pay itself back, expressed in days, months, and years. A typical way to calculate the payback time is to divide the investment amount by the annual cash flow that the investment produces (or saves in costs). For example, if an investment into a new recycling facility costs 1M euros, and the facility creates 100,000 euros in annual material savings, the payback period is 10 years (1M divided by 100,000). Although the payback period is very simple to calculate, the method does not consider the time value of money or opportunity cost. Because of this drawback, payback period calculations are often complemented with the Net Present Value method (see next).

For more information and the full formula: <https://hbr.org/2016/04/a-refresher-on-payback-method>

Net Present Value (NPV)

The Net Present Value (NPV) is another widely used method for comparing different investment alternatives or projects. While return-on-investment calculations give the estimated profit in percentages, the NPV method calculates the future value of an investment in today's euros. There are several benefits to the NPV method compared to many other techniques. Firstly, since the output of the calculation is in euros instead of percentages, it can be somewhat easier to compare different

alternatives. Secondly, when using the NPV method, the potential future cash flow that an investment produces is discounted to today's euro value, which takes the time value of money and opportunity costs into account. For example, if a manager considers investing in a new circular product line, he/she might have an alternative investment in mind that can produce 7% yearly returns. Using the NPV method, the future cash flows of the new product are calculated in today's euros by using the 7% return as a baseline comparison. If the present value of the discounted cash flows is positive, it means that the new product is a better investment than the best available alternative. If the present value is negative, the alternative is better. The drawback of the NPV method is that its reliability depends on the accuracy of the assumptions made during the calculation. For example, in the above example, the future cash flows of the new product and the 7% returns of the alternative would be based on the manager's estimations, which may or may not be accurate. The NPV method is also questionable from the point of view of sustainability, as it favours short-term benefits over long-term goals. NPV analyses should therefore be used as part of a more balanced assessment of sustainability costs and benefits to avoid sacrificing long-term values in favour of short-term gains.

For more information and the full formula: <https://hbr.org/2014/11/a-refresher-on-net-present-value>

4. Governance towards a data-driven circular economy

Annukka Berg, Katja Hilska-Keinänen, Liisa Pesonen, Milja Räisänen & Kristiina Valtanen

4.1 Introduction

This report has already shown the potential of data in a circular economy and its various practical applications and challenges. In this chapter, we familiarize the reader with the various governance questions related to a data-driven circular economy. The term governance is often associated with the regulatory powers of the state, but it is more fruitful to define it in a broader way. An example of such a **broad governance definition** is provided by Colebatch (2014): “the complex of formal and informal institutions, mechanisms, relationships, and processes between and among states, markets, citizens and organisations, both inter- and non-governmental, through which collective interests - - are articulated, rights and obligations are established, and differences are mediated.” In this chapter, we use this definition and emphasize the role of governance in spurring societal objectives such as digitalization and circularity in various ways.

From the governance perspective, circular economy and digitalisation are major, versatile, and turbulent fields for policy development. Therefore, it is challenging to grasp in depth how they intertwine. Moreover, governance solutions for a data-driven circular economy are covered by earlier literature in a relatively scattered manner. Thus, there are few sources in which the key drivers, obstacles, and potential governance solutions would be covered in a topical, holistic way (Berg, et al., 2021).

One of the pioneering works on the European level was published by European Policy Centre (EPC) in 2020 (Hedberg & Šipka, 2020). The researchers of the EPC conducted a series of 10 workshops in 2017–2019 and put together an EU framework for action with an impressive list of policy recommendations. The key message was that there should be a digital review of the circular economy transition and a sustainability review of the digital transition (European Policy Centre, 2020). The main recommendations included that EU defines a vision for a digitally enabled circular economy, uses policy tools such as regulation to provide a framework for action and economic instruments to encourage transition, and strengthens partnerships and empowers citizens. The study pinpointed a number of key areas of action: improvement of knowledge, connections and information sharing; making business models, products, and processes more circular; and strengthening the roles of citizens and consumers (European Policy Centre, 2020). In addition to the work conducted by the European Policy Centre, there have also been other important reports on the digital circular economy (Berg, et al., 2021; ECERA European Circular Economy Research Alliance, 2020; Kristoffersen, et al., 2020), but they have been targeted more at business developers and less at policy makers.

In Finland, the new strategic programme to promote a circular economy (Valtioneuvosto, 2021; Ministry of the Environment, 2021b) lists various **governance challenges for a data-driven circular economy**. These include a large part of materials and data currently flowing in closed, linear supply chains. Thus, circular economy-relevant data, information, or knowledge are not necessarily available for other actors of the same ecosystem, let alone customers. Yet, consumers and decision makers in both business and policy would need impartial, understandable, and comparable knowledge about the life cycle and environmental impacts of various products and investments. To allow this, the collection and sharing of data should be based on joint, standardized rules. The proposal of Finland's circular economy programme (Valtioneuvosto, 2021; Ministry of the Environment, 2021b) is that action should be taken to:

- **Define, gather and open the data relevant for a circular economy** within a network of key actors and particularly in the public sector.
- **Link various data sources** for the benefit of measurement activities and decision-making.
- **Promote digital circular economy infrastructures** both in Finland and abroad.

In Finland's circular economy programme (Valtioneuvosto, 2021; Ministry of the Environment, 2021b), the development of the circular economy architecture of Gaia-X (see Section 4.3.5. for further details) is a concrete initiative advancing both the digital and the circular agendas. The proposal is that Finland could play an active, international role as a developer of this initiative. Indeed, a massive amount of RDI work on different levels and spheres will be needed before a well-functioning, circular data economy can emerge. Participating in or staying tuned with international efforts can pay dividends in many ways.

From this perspective, good news is that a lot is happening, particularly on the EU level. The **EU is proposing a twin transition** that includes the Green Deal, also covering, for example, the new Circular Economy Action Plan and Sustainable Product Policy Framework, and key data initiatives such as Digital Strategy and Data Strategy. Figure 23 depicts key initiatives from both fields.

Governance towards data-driven circular economy - main drivers

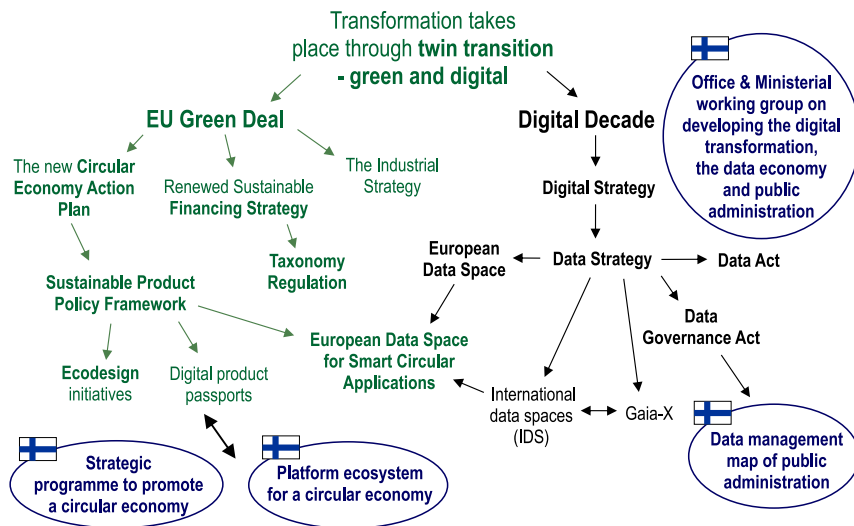

Figure 23. Governance towards a data-driven circular economy – key initiatives in Europe and Finland. In the figure, green text refers to mainly green/circular EU initiatives, black text to digitalisation/data initiatives, and blue text to national processes in Finland.

In this chapter, we seek to understand the twin transition in more depth and analyse its bearings for a country such as Finland. In particular, we try to get a hold of its main drivers and to find strategic ways to proceed. We discuss the twin transition by **mapping the most important green/circular economy and digitalisation initiatives in Finland and particularly in the EU**. We describe these initiatives and analyse their relevance for the promotion of a data-driven circular economy. In addition, we seek to understand their interconnections and joint dynamics. However, as many of the key initiatives in the field are scattered, we sometimes describe them as cases.

In the analysis work, we draw from previous literature on data and circularity (Berg, et al., 2021; Hedberg & Šipka, 2020). At the same time, we recognize that transformation towards a data-driven circular economy requires rather fundamental systemic changes. Thus, we use the 4Is framework (Brockhaus & Angelsen, 2012) derived from political economy research to sum up some of our results.

The main method of the study has been document analysis. We have started from the top green/circular and digitalisation/data strategies and continued from there to lower-level initiatives, strategies, and acts. Proceeding this way, and by discussing within our cross-disciplinary writer team, we have sought to find those initiatives, strategies, and acts that are most relevant for the development of a data-driven circular economy in Finland. Furthermore, we have interviewed 16 Finnish

experts from different spheres and sectors³ to find out how the EU-level strategies and acts are being implemented in Finland, and what kinds of pioneering projects have been or should be initiated on the national level.

We start our journey by first introducing the key EU initiatives. We then discuss their implementation in Finland, along with other interesting work taking place on the national level. In the end, we draw conclusions and propose ideas for a future data-driven circular economy governance strategy in Finland.

4.2 EU Green Deal paints the big picture for a green transition

The need for a more circular economy is clear, since our current global economy is only 8.6% circular and the trend has been downwards in recent years (CGRi, 2021). Since the start of the millennium, the EU's resource productivity⁴ has increased by around 35% (Eurostat, 2021b). However, as Figure 24 shows, the level of resource productivity varies widely between EU Member States. In this comparison, Finland is one of the least resource productive countries in the EU.

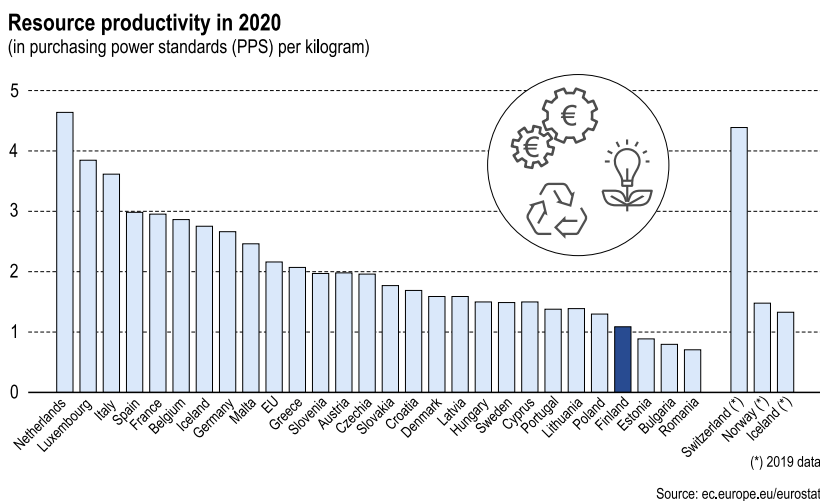

Figure 24. Resource productivity in different European countries. Adapted from an original figure by Eurostat (Eurostat, 2021b).

³ Andrea Weckman and Aino Kainulainen 17 February 2021; Vesa Siilfer, Motiva, 18 March 2021; Taina Nikula and Heikki Sorasahi, Ministry of the Environment, 19 March 2021; Tuomo Tuikka, VTT, 30 March 2021; Olli Salmi, EIT RM, 7 April 2021; Lotta Engdahl and Tuomas Kaivola, Ministry of Transport and Communications, 9 April 2021; Maria Kekäläinen and Markus Rähkola, Ministry of Finance, 9 April 2021; Jyri Arponen, Sitra, 16 April 2021; Antti Poikola, Helena Soimakallio and Jussi Mäkinen, Technology Industries of Finland, 16 April 2021; Sari Tasa, Ministry of Economic Affairs and Employment, 28 April 2021.

⁴ Resource productivity quantifies the relationship between the size of the economy and the use of natural resources.

While there is a lot to do to make the global, the European, or the Finnish economy truly circular, the current EU agenda for a green transition is ambitious: Europe aims to be the first climate neutral continent by 2050, to decouple economic growth from resource use and to ensure a just transition for all regions and people. The actions needed for reaching the objectives are set in the European Green Deal (COM-2019-640), presented in December 2019. The Green Deal is a growth strategy that renews climate legislation and presents new initiatives that, for instance, promote a circular economy. The implementation of the United Nation's Agenda 2030 is also refocused and strengthened as a part of the European Green Deal. The Green Deal initiatives cover a wide range of different sectors. Figure 25 presents the key policy areas and examples of related initiatives.

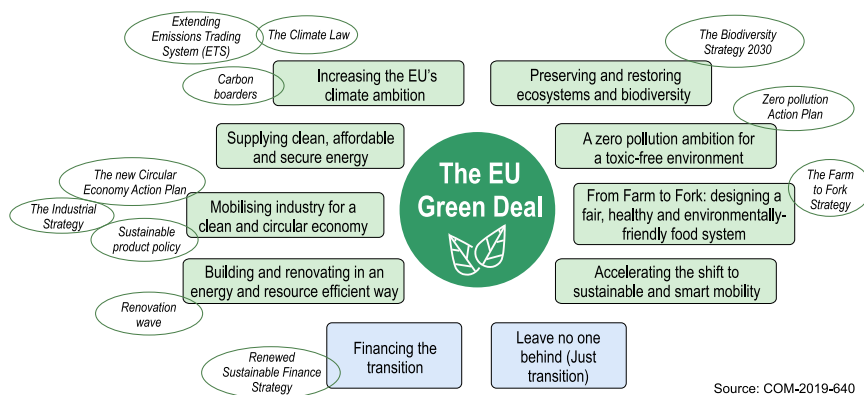

Figure 25. EU Green Deal policy areas and some of the related initiatives, actions, and strategies. Adapted from an original figure by the European Commission (COM-2019-640).

When implementing the EU Green Deal, digitalisation is expected to serve as an important catalyst in the transition. Accessible, interoperable, and reliable data together with digital technology (such as AI, 5G, and IoT) and digital infrastructures (such as supercomputers, cloud, and ultra-fast networks) strengthen evidence-based decision-making and provide new understanding of the environmental impacts of different actions. For example, digital technologies enable better monitoring and optimisation of resource use. In addition, digital passports can help product information, such as the origin, composition, renovation, dismantling, and end-of-use information, to stay attached to the product through its life cycle (and see 3.2.2).

The green and digital transitions together form a twin challenge that is addressed especially in the EU Industrial Strategy. Industry has a significant role in the European economy's transition to a climate neutral circular economy. In sum, data-driven circular economy measures are presented for several policy areas in the Green Deal. These include the renovation of buildings and sustainable food consumption. Circular economy criteria are also noted in the determination of

sustainable actions in the EU Taxonomy Regulation (COM-2018-97). The most important Green Deal initiatives that promote a data-driven circular economy are presented in more detail in the following sub-sections.

4.2.1 EU Taxonomy connects financing and the circular economy by 2023

For a sustainability transformation to take place, financing needs to be reformed. This aspect has been emphasized in the renewed Sustainable Financing Strategy (COM-2018-97), which is one of the key parts of the EU Green Deal. The strategy underlines that the investments needed for the twin transition are significant and require the mobilization of both public and private funds. However, already before the introduction of the strategy, green investing had started to gain global popularity. As Figure 26 shows, investments in sustainable funds have increased dramatically in the past few years, and active sustainable fund flows were estimated to be more than EUR 150 billion in 2020 (Morningstar, 2021).

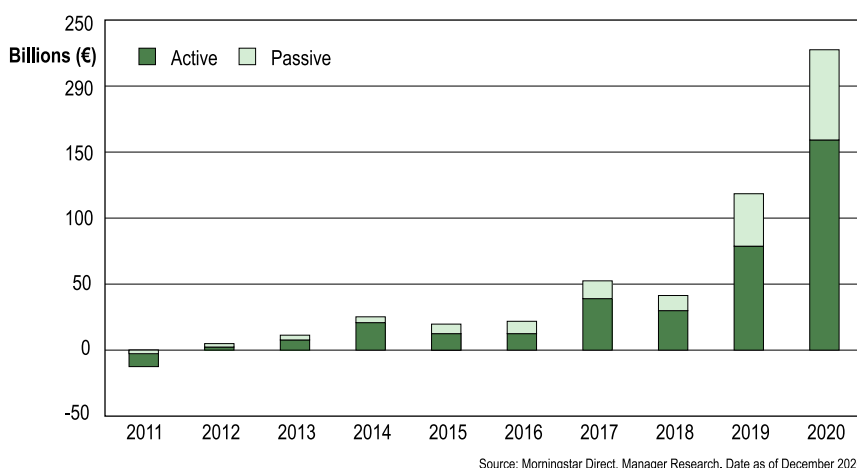

Figure 26. Annual European sustainable funds flow. Adapted from an original figure by Morningstar (Morningstar, 2021).

In the renewed Sustainable Financing Strategy (COM-2018-97), various mechanisms will be put in place to re-orientate capital flows towards a more sustainable economy, to mainstream sustainability into risk management, and to foster transparency and long-termism. These ten main mechanisms are depicted in Figure 27 and described in detail in the Financing Sustainable Growth Action Plan (COM-2018-97). There, the crucial element is the EU Taxonomy, a detailed classification system for sustainable activities. The technical criteria of the EU Taxonomy work as a backbone for the other actions in which, for example, standards and labels for green financial products will be created. Furthermore, companies and financial institutions are directed to disclose their climate and

environmental data so that investors are informed about the sustainability of their investments. And finally, climate and environmental risks will be incorporated into the financial system to make it more resilient.

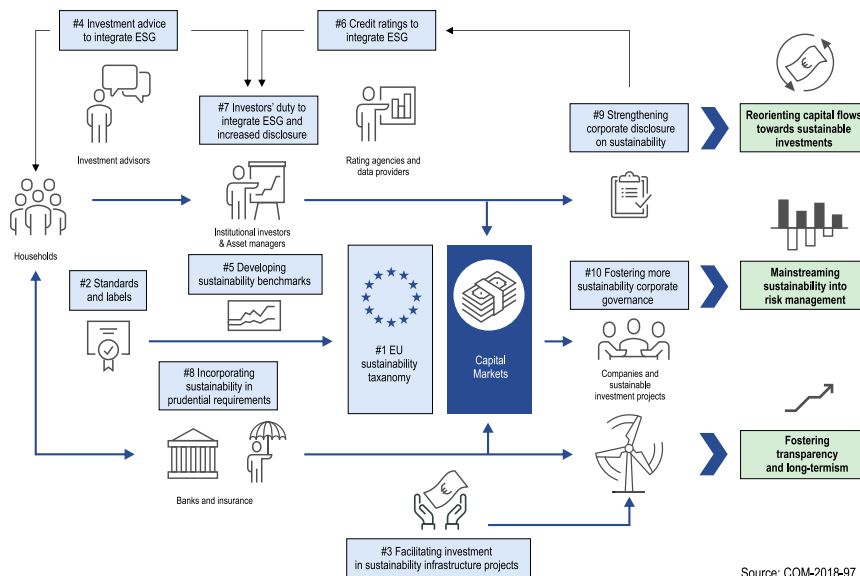

Figure 27. Financing Sustainable Growth Action Plan: Visualization of the actions. Adapted from an original figure by the European Commission (COM-2018-97).

For companies, green funding is a competitive financing option for investments. Furthermore, it provides a way for firms to reliably demonstrate their sustainability efforts, for example, for branding purposes. To be able to access green financing, the companies need to be able to prove to investors how much of their business is Taxonomy compliant. Briefly described, compliance is determined as follows (see also Figure 28):

- For an activity to be “environmentally sustainable”, the economic activity must substantially contribute to one of the six main objectives in the Taxonomy.
- Secondly, the activity must not cause any significant harm to any other Taxonomy objectives.
- Thirdly, the activity must meet the minimum safeguards regarding, for example, human rights.

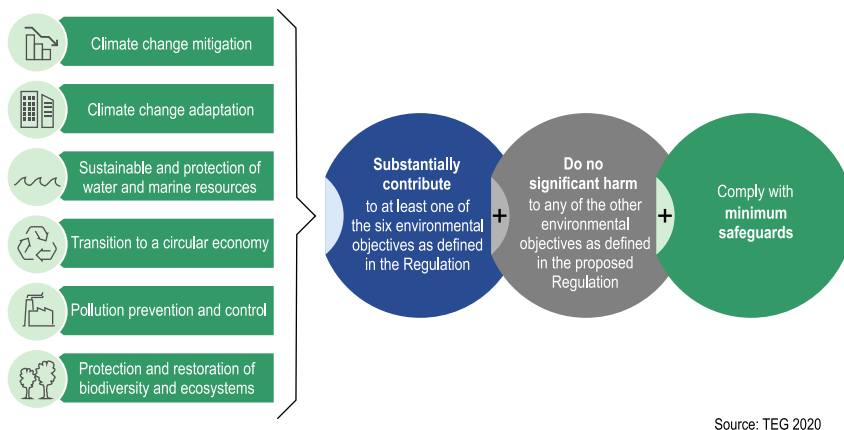

Figure 28. The six objectives and the technical screening criteria of the EU Taxonomy. Adapted from an original figure by the Technical Expert Group on Sustainable Finance (TEG, 2020).

If the data required for the compliance assessment is not available or cannot be verified, it shall be assumed that the target is not reached. This will significantly increase the value and, on the societal level, the availability of reliable and traceable sustainability data. **In summary, the EU Taxonomy will be a major driver for a data-based Green Deal and, thus, a circular economy.**

The EU Taxonomy covers all heavy-emission sectors, and the Technical Expert Group on Sustainable Finance (TEG) has identified activities inside these sectors that can make a substantial contribution. For two of the objectives, climate change mitigation and adaptation, the technical screening criteria have already been defined and were expected to come into force by the end of 2021. For the rest of the objectives, the plan has been that the criteria will be established and come into force by the end of 2022. The Taxonomy should be fully operational by 2023.

From the perspective of a circular economy, especially interesting will be the criteria regarding the objective of “transition to a circular economy”, well introduced, for example, in the Introduction to the EU Taxonomy for a Circular Economy by Bär & Schrems (2021). **The delegated act regarding the circular economy objective** is expected to be adopted in the first half of 2022. However, in the end of the year 2021, only some initial frameworks and proposals for the technical screening criteria were available:

- The European Commission’s Support to Circular Economy Financing Expert Group has outlined **a framework for a generic, sector-agnostic circular economy categorisation system** that defines distinct categories of activities substantially contributing to a circular economy and a set of minimum criteria to be met by activities under each defined category to be considered as substantially contributing to a circular economy (European Commission, 2020e).

- In addition, the Platform on Sustainable Finance's Technical Working Group (TWG) has published **a preliminary set** (TWG, 2021a; TWG, 2021b) **of recommendations for the EU Taxonomy technical screening criteria** for objectives 3–6, and thus also for “transition to a circular economy”. However, the criteria are not yet complete and the next update for all six objectives is scheduled for Q3 2022.

The screening criteria for the circular economy objective have been regarded as really challenging to create, since circular economy is a relatively new concept in the scientific literature and there is no quantitative overarching EU ambition level for a circular economy (TWG, 2021a). Therefore, the criteria strongly build on the EU Circular Economy Action Plan and its role as an enabler helping to achieve other environmental objectives. In summary, several activities that can be regarded as a significant contribution to the transition to a circular economy have been drafted. They fall into the following main categories (TWG, 2021b):

- Circular design and production
- Circular use
- Circular value recovery, and
- Circular support

In the future, the **Taxonomy is likely to be extended** to also include performance criteria for activities that are environmentally significantly harmful (SH) or have no significant impact (NSI). These additions would address the issue of using the green Taxonomy as a binary instrument strictly separating “green” and “not green” activities. The idea is to give recognition and ensure access to capital to corporates that are transitioning towards a more sustainable business model, but whose activities fail to meet a significant contribution (SC). (TWG, 2021c) Furthermore, the more fine-grained classification of different environmental performance levels would increase the currently narrow supply of Taxonomy-aligned financial assets, making them more widely available, but still preserving the incentives to strive towards greener options.

Lastly, the EU Taxonomy not only guides financing, but also provides valuable insight, for example, for business development and innovation. The methodology used in the creation of the Taxonomy has required a substantial data collection effort, assessments, verifications, and multi-criteria analysis on impacts, reduction potentials, and potential costs. The result is a comprehensive science-based listing of economic activities prioritized based on their potential to reduce environmental pressure, and it can also be freely utilized beyond financial purposes, for example, in designing more sustainable business.

In summary, the EU Taxonomy will clearly increase reporting obligations for those companies who want to gain access to cheaper green funding instruments. Successful reporting to achieve Taxonomy compliance will require reliable and traceable sustainability data, which means that companies should prepare to closely coordinate reporting and information gathering across their supply chains. Additionally, the requirement for verified data is likely to emphasize the importance

of data quality. As a result, **by presenting clear financial incentives for increasing data quality, availability, and sharing across supply chains, it can be expected that the EU Taxonomy will not only speed up the transformation towards sustainability, but also boost the general industrial data sharing efforts.** All these efforts can significantly pave the way towards a data-driven circular economy.

4.2.2 The new Circular Economy Action Plan guides the transition towards circularity in the EU

As one of the key actions implementing the EU Green Deal, a new Circular Economy Action Plan – For a cleaner and more competitive Europe (CEAP) (COM-2020-98) was adopted in March 2020. The overall objective of the plan is to establish a product policy framework that advances the sustainability of products, services, and business models. It also aims to prevent waste production by affecting consumption patterns. The key actions presented in the plan fall under seven themes: A sustainable product policy framework; key product value chains; less waste, more value; making the circular economy work for people, regions, and cities; cross-cutting actions; leading efforts at the global level; and monitoring the progress.

According to the action plan, a circular economy can strengthen the EU’s industrial base and promote business creation when built on the single market and the potential of digital technologies. The Internet of Things, big data, blockchain, and artificial intelligence are identified as technologies accelerating circularity and dematerialization, or “digital tools to achieve circular objectives”. The CEAP initiatives regarding data-driven and digital solutions for circularity are presented in Table 7.

Table 7. *The initiatives regarding data-driven and digital solutions in the Circular Economy Action Plan (COM-2020-98).*

CEAP Theme		Initiative
A sustainable product policy framework	Circularity in production processes	In synergy with the objectives laid out in the Industrial Strategy, the Commission will enable greater circularity in industry by promoting the use of digital technologies for tracking, tracing, and mapping of resources.
	Designing sustainable products	As part of a sustainable product policy legislative initiative, the Commission will consider establishing sustainability principles and other appropriate ways to regulate. The aim is to mobilise the potential of digitalisation of product information, including solutions such as digital passports, tagging and watermarks. To support the effective and efficient application of the new sustainable product framework, the Commission will establish a common European Dataspace for Smart Circular Applications with data on value chains and product information. The European Dataspace for Smart Circular Applications will provide the architecture and

CEAP Theme		Initiative
		governance system to drive applications and services such as product passports, resource mapping and consumer information.
Less waste, more value	Enhancing circularity in a toxic-free environment	To increase the confidence in using secondary raw materials, the Commission will co-operate with industry to progressively develop harmonized systems to track and manage information on substances identified as being of very high concern and other relevant substances, in particular those with chronic effects and substances posing technical problems for recovery operations present along supply chains. The Commission also seeks to identify those substances in waste, in synergy with measures under the sustainable products policy framework and with the ECHA Database on articles containing substances of very high concern.
Key product value chains	Construction and buildings	To exploit the potential for increasing material efficiency and reducing climate impacts, the Commission will launch a new comprehensive Strategy for a Sustainable Built Environment . It will promote circularity principles throughout the life cycle of buildings, for example, by promoting measures to improve the durability and adaptability of built assets in line with the circular economy principles for buildings design and developing digital logbooks for buildings.
Cross-cutting actions	Getting the economics right	The Commission will enhance disclosure of environmental data by companies in the upcoming review of the non-financial reporting directive as well as support a business-led initiative to develop environmental accounting principles that complement financial data with circular economy performance data. Also notice the Commissions initiative of integrating the circular economy objective under the EU Taxonomy Regulation (see more about this subject in Section 4.2.1)

The potential of digital technologies to promote circular economy is associated with product and resource information. It is pointed out that these technologies can help to trace the journeys of products, materials, and substances, thus making the value chains more transparent. The data provided need to be securely accessible. For this purpose, the Commission intends to establish the European Data space for Smart Circular Applications. Digital product passports are one example of the solutions that provide high quality data for the common European Data space (see Sections 4.3.3 and 4.3.4).

The CEAP aims to attain a cleaner and more competitive Europe, where safe and sustainable products are the norm. To support this goal, the Chemicals Strategy for Sustainability (COM-2020-667) will catalyse the shift towards chemicals, materials, and products that are inherently safe and sustainable through their whole life cycle. In product design, this means consideration of durability, reusability, upgradability, and reparability, which enable the reuse and recycling of materials without compromising the safety of human health and biota arising from hazardous

chemicals. **Safe and sustainable by design (SSbD)** is a pre-market design approach that addresses these objectives. To achieve the overall objective, the Commission has committed to developing SSbD criteria by 2022.

In summary, through the new CEAP, the Commission is accelerating the development of product policy to ensure the sustainability of products, services, and business models. The plan introduces the potential for digital solutions in the circular economy and thus promotes both green and digital transitions. The digital solutions mentioned in the plan, such as product passports and digital logbooks of buildings, make efficient use of data, enabling the promotion of circular economy principles and safety throughout the life cycle of a product or service. Such solutions are at the heart of a data-driven circular economy, and with CEAP and digital initiatives, the EU is taking its first steps to unlocking these opportunities.

4.2.3 Ecodesign makes products work for sustainability

The Ecodesign Directive of the EU aims at targeting a product's energy consumption and is closely related to the Energy Labelling Directive. With the Ecodesign Directive, manufacturers are guided towards designing and producing more energy-efficient products, and the Energy Labelling Directive helps consumers to choose the best products on the market by promoting a clear labelling scheme. The Ecodesign Working Plan continued this work and is seen as an important part of the Circular Economy package. The Working Plan added several new product categories on the side of the product lots established earlier. **The idea behind these actions is that the European market is only open for environmentally friendly products that consume energy sustainably and are repairable and recyclable.**

The European Commission has promoted the implementation of eco-design for a few decades already. The first Ecodesign Directive (Directive 2005/32/EC) set requirements for energy-using products, for example household equipment such as washing machines and refrigerators. In 2009, the Directive was replaced by a more extensive Ecodesign Directive (Directive 2009/125/EC), which covered a wider scope of energy-related products, for example products used in construction such as windows, insulation materials, or shower heads.

The Ecodesign Directive is implemented through product-specific regulations, directly applicable in all EU countries. According to the Ecodesign Directive, products are eligible for measures if they meet certain criteria regarding sales volumes and significance in environmental impact or the potential to improve it. It is difficult to formulate *ex ante* whether any of these significant impacts apply, which is why there is a standard procedure for carrying out such preparatory studies (BIO Intelligence Service, 2013). The product-specific preparatory studies comprise, for example, a market, user, and technology study, an LCA and LCC study, design options assessment, and scenario analysis (see e.g., 3.3).

To strengthen the goals that are behind the Ecodesign and Energy Labelling Directives, several initiatives have been launched, which bring the European product market further regarding a sustainable, circular economy. One of these

initiatives is **Consumer policy – strengthening the role of consumers in the green transition**. The initiative prevents greenwashing and helps consumers to receive reliable information on sustainable products in the EU.

Another initiative supporting the circular economy is the **Sustainable products initiative**. This initiative aims at making products placed on the EU market more sustainable and it will revise the Ecodesign Directive. Both consumers and the environment will benefit from longer product lives, making **consumer products more durable, reusable, repairable, recyclable, and energy efficient**. The initiative also considers harmful chemicals that are used in many consumer products, such as electronics, ICT accessories and equipment, textiles, and furniture, and also construction and renovation materials such as steel, cement, and chemicals. Hence, adoption of the initiative will necessitate a more thorough tracking of hazardous substances in production processes.

Both the Consumer policy initiative and the Sustainable products initiative seem to be welcomed by the stakeholders, since, for instance, greenwashing is seen as a major challenge that both manufacturers and consumers want to overcome.

In summary, for a data-driven circular economy, the various EU eco-design initiatives have already meant a lot. The product-specific preparatory studies conducted based on the Ecodesign Directive have produced a substantial amount of circular economy-relevant information such as LCA studies, design option assessments, and scenario analyses.

4.2.4 Product labelling – from early pioneers to PEF

Already for some decades, designers, manufacturers, and consumers alike have been guided towards sustainability and a circular economy with authorized labels and badges that are used in communication and the marketing of products. In Finland alone, nearly 40 ecolabels that are used in consumer communication exist.

The best known and widespread ecolabels are the EU Ecolabel and the Nordic Swan Ecolabel, which are both governed in Finland by Ecolabel Finland. Ecolabel Finland participates in the preparation of the eco-labelling criteria for each product group and processes and issues the licenses for their use.

The Nordic Swan ecolabel was established in 1989, and it is the official ecolabel of the Nordic countries. It is issued only for those products and services that are the best in their product group from an environmental perspective. The label can be applied for a product or service such as toilet paper or hotel service by a manufacturer, importer, or service provider. The requirement is that eco-labelling criteria confirmed by the Nordic Ecolabelling Board need to be met by the product or service. Currently, nearly 70 different product group criteria have been confirmed by the Board.

The criteria of the Nordic Swan label refer to a product's whole life cycle, from production to consumption. Raw materials, production processes, use, disposal, and recycling are all considered when applying for the label. The quality requirements ensure that the product is also efficient and durable.

Meanwhile, the EU Ecolabel was established in 1992 and covers nearly 30 product groups. Products carrying the EU Ecolabel have undergone strict tests that ensure their superior environmental and quality performance. As is the case with the Nordic Swan, the criteria of the EU Ecolabel consider all the stages of a product's life cycle, from the first production stages to the disposal and recycling of the product.

Manufacturers, designers, and importers of products have to apply for the use of the labels and prove that they meet the criteria in the selection process. When applying for the Nordic Swan label, for example, applicants must provide primary data on all their functions and products that are covered by the criteria. It is expected that the applicant who has the primary data also has the power to change the operations to achieve environmental goals. Unfortunately, however, the data used in the application process is related to monitoring of the activities of a company and its supply chain and might not be very useful from a broader circular economy perspective. (Salo, Suikkanen, & Nissinen, 2019a).

Particularly the Nordic Swan Ecolabel, but also the EU Ecolabel have been pioneers in their field. Nowadays, the environmental impacts of products and services are communicated through a myriad of labels and claims. In the EU alone, there are more than 200 active environmental labels (European Commission, 2021b). Some of them have strict criteria set by a third party, but some are self-declared by companies. **In the worst case, these self-declared labels give misleading information or a misleading impression about the environmental performance of a product or service,** leading to so-called greenwashing.

In the EU, this problem of unfounded environmental performance or sustainability claims has been raised in the EU Green Deal, the Circular Economy Action Plan, and the Farm to Fork strategy (see Sections 4.2, 4.2.2, 4.2.8). Currently, the Commission is preparing new legislation that would oblige companies to substantiate environmental claims. **The green claims initiative** (European Commission, 2021b) **seeks to promote a standardized method to evaluate environmental performance.** Thus, the veracity of the claims could be assessed, and the claims would be comparable with each other. **Product and Organisation Environmental Footprint methods (PEF and OEF) have been proposed as suitable evaluation tools** in the Circular Economy Action Plan (COM-2020-98).

The PEF is a life cycle-based method to calculate a product's environmental performance. It was developed by the European Commission to harmonise environmental footprinting methodology (European Commission, 2021b). It includes 17 product groups with group-specific rules (PEFCRs), and it evaluates the environmental performance with 16 impact categories including resource depletion, toxicity, and climate change. The PEF will strengthen the single market for green products. (Salo, Suikkanen, & Nissinen, 2019b)

Meanwhile, the Organisation Environmental Footprint (OEF), another initiative by the European Union, targets the creation of a shared methodology for environmental performance calculations for organisations. OEF enables the use of open, high-quality data to make trustworthy calculations for each organisation's environmental footprint.

Compared to previous methods, PEF and OEF were designed to offer several advantages. Among these are the clear identification of the potential environmental impact requiring assessment in a comprehensive Life Cycle Assessment (LCA), as well as various data quality requirements. Both methods are accompanied by Category Rules (CR), allowing easier comparison of products or sectors by focusing on just three or four environmental impacts. (European Commission, 2013)

In summary, some product labels such as the Nordic Swan Ecolabel and the EU Ecolabel have been pioneering in environmental data production. Thus, they have provided important references for showing that environmental claims need to be proven with reliable and valid data. Furthermore, they have been important developers for the criteria and methodologies, setting the scene for others to follow. From the circular data perspective, environmental product labels could also be developed even further. This would imply that the potential powers of the labels would be used for opening, improving, and enhancing the exchange of data with commonly shared standards, applying, for example, the FAIR principles for research data. However, it could be an essential addition to the criteria of the labels that the applying bodies would also be asked to share the data continuously and openly regarding their production, logistics, distribution, and other processes with common standards when applying for the use the labels. However, ensuring continuous data provision from the actors would require motivation and resources from the data providers and continuous dialogue among regulators, providers, and users of the data.

4.2.5 Case: Product passport for batteries – an electronic record to enhance sustainability

In the EU, the idea of a product passport has been presented in several strategies (COM-2019-640; COM-2020-98; COM-2020-66). It is a digital solution that promotes the sustainability of products through the information that accompanies them. In the strategies, **a product passport is outlined to include information on a product's origin, durability, composition, reuse, repair, and dismantling possibilities** (COM-2020-66).

Access to information enables consumers to make more informed choices. It also **promotes value-retaining operations such as use-optimisation, sharing, servitisation, reverse logistics, predictive maintenance, reuse, repair, refurbishment, and recovery of components and materials** (Lemos, 2020).

Developing product passports is linked to the process of establishing a common European Data Space for Smart Circular Applications that will provide the architecture and governance system to drive data-based circular applications and services (COM-2020-98).

For batteries, the concept of a battery passport was initially presented by the Global Battery Alliance (GBA) in January 2020. It is one of the flagship deliverables of the work GBA has committed to do to promote sustainability in the battery value chain. According to GBA, the Battery Passport aims to provide transparency of the value chain, create a framework for benchmarking and standardizing the

sustainability performance, and validate and track the sustainability progress. (GBA, 2020)

The GBA Battery Passport will be a digital twin of a physical battery. Basically, it will be a sustainability certificate that contains all applicable information on environmental, social, governance, and life-cycle requirements involving all actors in the battery value chain (Figure 29). (GBA, 2020)

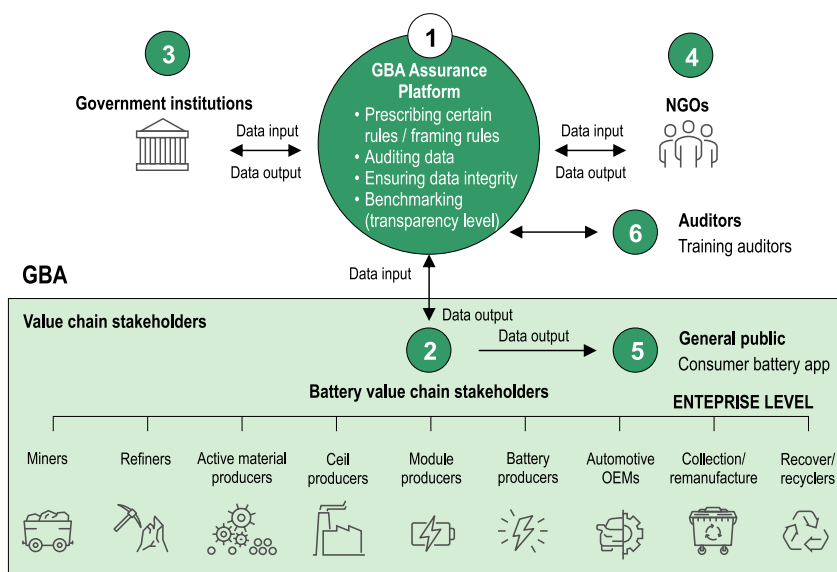

Source: GBA 2020

Figure 29. The concept of GBA Battery Passport. Adapted from an original figure by the Global Battery Alliance (GBA, 2020).

The proposal for new batteries regulation in the EU (presented in December 2020) supports the development of a battery passport. According to the proposed regulation, each industrial battery and electric vehicle battery placed on the market or put into service and whose capacity is higher than 2 kWh shall have a unique, electronic record (“battery passport”) by January 2026.

The following points are important for understanding how the proposed EU battery passport will work in practice (COM-2020-798):

- Each battery will be identified by a unique printed or engraved identifier.
- The economic operator that places an industrial battery or an electric vehicle battery on the market will ensure that the data included in the battery passport is accurate, complete, and up-to-date.
- The access to information will be divided to three user groups: “public”, “accredited economic operators and the commission”, and “notified bodies,

market surveillance authorities and the commission". The information accessible for each group is presented in the proposal.

- All information will be stored in an electronic exchange system that the Commission will set up by 2026.

4.2.6 Case: Ownership is reconsidered in a circular economy

In a circular economy, the traditional concept of owning products is about to undergo a change when sharing, renting, and other kind of services take a bigger role. With its product policy framework, the new Circular Economy Action Plan promotes business models that aim at savings in material and energy consumption and thus contribute to the overall sustainability of products. The basis for value creation of a product is remodified and the intelligence of goods is highlighted (Rajala, et al., 2018).

To keep materials in circulation, mechanisms such as Extended Producer Responsibility (EPR) have been introduced for different products. An EPR scheme sets the responsibility for a post-consumer product to be managed by producers. From the perspective of EPR, the next step towards strengthening the responsibility of a producer would be a producer ownership model that widens the focus from waste management and recycling to a more comprehensive idea of ownership change (Orasmaa, Laurila, & Liimatainen, 2020; Domenech, et al., 2019).

Providing a product as a service is already a typical circular economy strategy, but in addition to products, materials and performance can also be provided as services. All of these are referred as producer ownership models, in which the ownership remains with the producer instead of the user (which could be business or consumer). Function guarantees, such as extended warranties and deposit systems, can also be considered producer ownership models (Table 8). As the ownership remains with the producer, it encourages more circular design, as the producer is responsible for ensuring the most efficient use of materials and products throughout their life cycle (Sitra, 2021a). These business models are usually complemented with data platforms and other digital solutions. (Orasmaa, Laurila, & Liimatainen, 2020; Domenech, et al., 2019)

Table 8. *The main categories of producer ownership models and solutions supporting them. Adapted from Orasmaa, Laurila, & Liimatainen (2020), original source of information Domenech et al. (2019).*

Model of producer ownership	Description
Product-as-a-service	A service model in which the customer rents or leases the product instead of buying it. The service provider owns the products and is responsible for their maintenance.
Material-as-a-service	A service model in which the manufacturer of the materials produces and owns the materials, but the customer is responsible for their use.
Performance-as-a-service	A service model in which the customer buys a “performance” instead of owning and using a product.
Function guarantee	1) A lifetime warranty for a product, with the producer taking responsibility for the product’s maintenance and longevity. 2) Deposit systems that ensure that products are returned from the customer for subsequent reuse, remanufacture, repair, or use as raw material in production.
Solutions that support producer ownership	Description
Sharing platforms and digital solutions	Digital sharing platforms and solutions that make it possible to increase the usage rate of goods and other resources through renting and sharing, for example. In this model, the platform operator does not directly own the resources that are rented and shared on the platform, but nevertheless holds a key role in the effective functioning of the business model.

However, to fully unlock the potential of producer ownership models in the circular economy, policies should support their introduction. This refers to consumer legislation, but also, for example, public procurement and taxation. (Sitra, 2021a)

Nowadays, products contain and handle increasing amounts of data about, for instance, their real-time condition, location, use, and history. In industry, the growing amount of data shifts the value creation toward service-based models to meet the increasing needs of customers (Rajala, et al., 2018). The relationship with and interests in data vary between the actors in a value chain. In addition to defining the owner of data, it is necessary to determine who has access to the data, who controls the data, and who has the right to utilize the data. (Rajala, et al., 2018)

4.2.7 The European Industrial Strategy aims for a more competitive yet sustainable digital Europe

Industry lays the foundations for the EU economy. It leads the twin transition and thus has a significant role in the change from a linear to a circular economy. A new

Industrial Strategy for Europe was published in March 2020 (COM-2020-102) and updated in May 2021. It describes the industrial policy that is needed for the twin transition, enhancing the competitiveness of EU industry and strengthening Europe's strategic autonomy. The 2021 update adjusts the strategy to post-COVID-19 circumstances and prioritizes crisis-relevant policy areas such as Single Market resilience, Europe's strategic dependencies, and the acceleration of the twin transition.

The strategy describes three drivers for industrial transformation: A globally competitive and world-leading industry, an industry that paves the way to climate-neutrality, and an industry shaping Europe's digital future. In order to maintain the competitiveness of the industry and to simultaneously implement the twin transition, the strategy suggests that it is necessary to focus on innovation, for example, in novel industrial processes and clean technologies, and securing adequate funding for them. **The focus is set on industrial ecosystems, with digital industries being one of the 14 ecosystems.** In this way, all actors in value chains of each ecosystem can be properly accounted.

Building a more circular economy is essential to industry transformation, and the Circular Economy Action Plan thus complements Industrial Strategy, and vice versa. Multiple circular economy actions are already taking place within industry, but **concerns about the sufficiency of raw materials is further accelerating the introduction of circular economy measures, especially in manufacturing.**

The security of supply is a common topic in raw materials discussions and is linked to Europe's dependence on the rest of the world. In the future, the demand for raw materials is expected to grow notably. Critical materials in particular play an important role in enabling digitalisation and achieving climate goals. The strategy initiates an Action Plan on Critical Raw Materials and an industrial alliance for raw materials (European Raw Materials Alliance ERMA).

For Europe, it is important to be a global leader in digitalisation. Building on existing strengths and staying at the forefront of digital innovation (such as 6G) will help in retaining Europe's technological and digital sovereignty. **Europe is leading in the use of industrial data but lags, for example, in cloud and data applications.** As European industry is based on a strong single market, the digital and well-functioning single market needs to be enforced. In the twin transition, all value chains are important, and all sectors should be supported to create individual roadmaps for achieving digital leadership. As digitalisation proceeds, the capacity of the digital infrastructure needs to be maintained and the intellectual property, such as data and algorithms, of all actors needs to be secure. (COM-2020-102) The following sections will shed more light on the digital agenda of the EU.

In summary, the twin transition will bring major changes to European industry as Europe seeks not only to adapt to but also to lead the change. This means investing in the development of novel technologies required by digitalization and carbon neutrality targets. More actions will rely on data, and a single market for data will be developed. These changes are both opportunities and challenges to business, industry, and the economy. The competitiveness of European industry is boosted

by staying at the forefront of development and enabling solutions, such as a data-based circular economy, that serve both aspects of the twin transition.

4.2.8 Case: Farm to Fork Strategy and the new CAP support the sustainability transition of the food system

The food system accounts for about 10% of all GHG emissions in the EU and therefore has a significant role to play in achieving the EU's carbon neutrality goal. The Farm to Fork strategy (COM-2020-381) was established in 2020 under the Green Deal to support the sustainability transition in the food system. The emphasis of the strategy is on food production. As regards the new CAP (Common Agricultural Policy) for 2023–2027, an agreement was reached in June 2021. Spurring the twin transition in agriculture is one of the objectives highlighted in the CAP.

From a circular economy point of view, a very relevant initiative is the new EU carbon farming initiative, which promotes a new kind of business model called carbon sequestration: an action that removes CO₂ from the atmosphere. This initiative is mentioned in the Farm to Fork strategy but is officially published under the Climate Pact. Furthermore, in the Circular Economy Action Plan (COM-2020-98), the Commission commits to developing a regulatory framework for certifying carbon removals.

Adopting circular economy actions in the whole food system will help not only in achieving climate goals but also in taking steps towards overall sustainability. The strategy introduces actions such as refining biowaste and side streams, for example, to bio-fertilizers, bioenergy, or bio-chemicals, improving packaging solutions and food contact materials, and reducing food waste with the help of a new measuring methodology and data from the EU Member States.

Better use of data and analysis as well as investing in cleantech, digital technology, and related practices are identified as ways to help farmers to improve their environmental and climate performance in the new CAP. 'Producing more with less' is a goal that includes the adoption of new technologies, knowledge transfer, and skills training. The strategy also points out the intention to set up a Common European Agriculture Data Space that will be utilized to process and analyse production, land use, environmental, and other data. Thus, the data space can allow the precise and tailored application of production approaches at farm level and the monitoring of performance of the sector, as well as supporting the carbon farming initiative.

It is obvious that a high-quality Internet connection is essential to unlock the full potential of digital solutions in agriculture and to speed up the sustainability transition. Therefore, the Commission has set an objective of 100% Internet access in rural areas by 2025. This would enable, for example, the mainstreaming of precision farming and use of artificial intelligence, as well as the exploitation of the potential of satellite technology. According to the strategy, this will result in cost reductions for farmers, improve soil management and water quality, reduce the use of fertilisers, pesticides, and GHG emissions, improve biodiversity, and create a healthier environment for farmers and citizens. (COM-2020-381)

4.3 EU's Digital Decade shows the way towards Europe's digital future

The utilization of data and digital services is one of the key factors influencing Europe's development and global competitiveness. A data-driven economy enhances sustainable development and the growth of economies by enabling better situational awareness of available resources and demand, improved control of processes, and agile agreements between actors. Data means power, and **Europe therefore aims to build its digital future based on its values of equality, fairness, and democratic development.**

There are several challenges to settle before the target is reached (European Commission, 2020a). Digital infrastructures, i.e., broadband and 5G networks, need to be built to cover the whole of Europe. In 2019, next generation access service was reached by 86% of EU households, but only 44% of households had access to a gigabit-speed Internet service. Only 17 Member States had assigned spectrum in the 5G pioneer bands. Finland is among the most advanced countries in terms of 5G readiness. While 39% of large companies used advanced cloud services and 33% used big data analytics, only 17% of SMEs used cloud services and only 12% big data analytics. In Finland, 50% of companies used cloud services in 2019.

In order to be widely usable, data requires organisation and systematic handling by the data providers, i.e., as in the case of High-Value Data Sets (European Commission, 2020b). The ability to utilise new digital enablers in business and other activities needs improvement. In 2019, only 58% of Europeans had basic digital skills. Further, digital public services were available for 67% of Internet users in Europe.

The aimed efficient utilisation of data for sustainable growth requires establishing dataflows between actors of diverse sectors and between the sectors, and also cross-country. While doing so, it is important to retain individuals' and companies' privacy, data security, and trust in safe digital systems. Europe is building a single digital market that aims at providing equal business opportunities and services throughout Europe. This challenges the interoperability of digital systems and data even more than before. A particular challenge is how new technologies and services can interact with old systems and data sources without causing extra e-waste.

The digital transformation in Europe begun in the last decade, when progress towards the **Digital Single Market** started. The aim has been to establish a frictionless single market, where companies of all sizes and in any sector can compete on equal terms. The goal is that companies can develop, market and use digital technologies, products and services at a scale that boosts their productivity and global competitiveness. Further, consumers should be confident that their rights are respected. The digital strategy also currently includes the aim of technology that works for all, a concept of open, democratic, and sustainable digital society, and defines Europe as a global digital player.

As a next step on the way to the Single Digital Market, in February 2020, the European Commission released the **European Data Strategy**, the vision of the European data economy, to communicate policy goals and the framework for more

efficient utilization of data in businesses and societies in Europe. It aims at creating “a genuine single market for data, where personal and non-personal data, including confidential and sensitive data, are secure and where businesses and the public sector have easy access to huge amounts of high-quality data to create and innovate. It will be a space where all data-driven products and services fully respect EU rules and values” (COM-2020-66). Thus, the data strategy fully complies with GDPR, giving individuals control of their data. The framework for digital development is complemented with the White Paper on Artificial Intelligence – A European approach to excellence and trust, which aims to turn Europe into the global hub for trustworthy artificial intelligence (AI) (COM-2020-65).

In the spring of 2021, the digital transition pursued in Europe was named the **Digital Decade**. It is a roadmap until the year 2030 and describes the targets and actions for this decade. It sets targets for diverse aspects of society, namely for infrastructure, skills, businesses, and government. The common targets, called the Digital Compass (Figure 30), set by this roadmap are:

- a digitally skilled population and highly skilled digital professionals
- secure and substantial digital infrastructures
- digital transformation of businesses
- digitisation of public sectors

The key enablers to achieve the targets are cloud computing, artificial intelligence, digital identities, data, and connectivity.

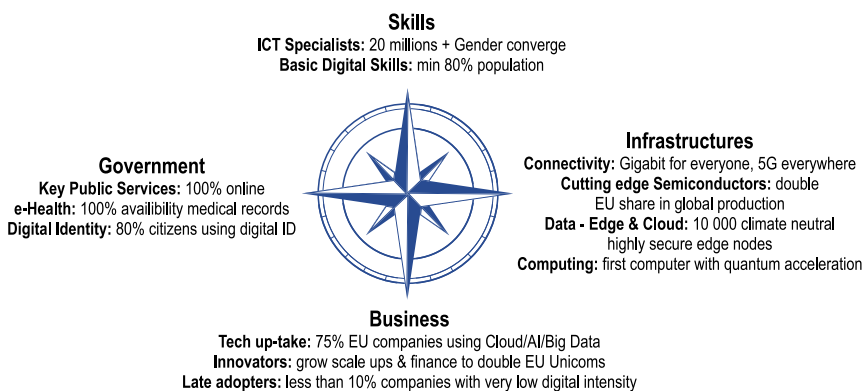

Source: EU 2021. 2030 Digital Compass, The European Way for the Digital Decade

Figure 30. The EU's Digital Compass with diverse targets to meet within this decade. Adapted from an original figure by the European Union (European Union, 2021).

The Finnish Government set up a Ministerial Working Group on Developing the Digital Transformation, the Data Economy and Public Administration in autumn 2021. The working group decided to create a digital compass for Finland during

spring 2022. The objective is to formulate a shared national vision and targets for digital transformation and the data economy for 2030. A coordination group for digitalisation called 'Digitoimisto' (Digital office) was established to support the work of the Ministerial Working Group. It is a permanent interministerial working group tasked with strengthening interministerial cooperation, coordination, and the flow of information.

4.3.1 The Digital Decade and the Data Strategy are supported by several legal instruments

There are several legal instruments to support the digital transformation. The instruments include:

- Data Governance Act
- Digital Markets Act
- Digital Services Act
- Implementing Act on High-value Datasets under the Open Data Directive
- Data Act
- Cybersecurity Act
- Artificial Intelligence Act

Of the key instruments, the **Data Governance Act** (COM-2020-767) aims to ensure trust in data transactions so that public sector data, private sector data, and personal data can be voluntarily made available by data holders. The European Commission delivered the Data Governance Act at the end of 2020 in order to regulate the re-use of certain protected data categories in the possession of the public sector, the requirements applied to the data intermediary services and acknowledged data altruism organizations. The Data Governance Act would also regulate the related regulatory and other tasks and the transfer of data to third countries. In addition, the proposed regulation would establish the European Data Innovation Board, which would strengthen the data sharing procedures in the EU and create a framework for the operation of European data spaces (see Section 4.3.3. for more details).

Released in the first quarter of 2022, the **Data Act** aims to ensure fairness in the allocation of data value among the actors of the data economy. This concerns private sector data, personal data, and co-generated (IoT) data. According to the tentative information available, the Data Act should enhance data sharing from business to government and intervene in the usage rights of commonly produced data i.e., Internet of Things data from industrial environments, which are typically agreed in private agreements. In addition, the Data Act assesses the system of industrial and intellectual property rights to intensify the availability and usage of data. This includes possible re-examining of the Database Directive (Directive 96/9/EC) and a clarification of the Trade Secrets Directive (Directive 2016/943) on the protection of undisclosed know-how and business information (trade secrets) against their unlawful acquisition, use, and disclosure.

Furthermore, the European Commission has delivered proposals for regulations regarding digital services and digital markets. The **Digital Services Act** (COM-

2020-825) ensures the proper functioning of the single market for digital services to enable the best conditions for innovative cross-border digital services to develop. It aims also to maintain a safe online environment and to protect fundamental rights. The Digital Service Act proposes obligations for the transparency of content monitoring of web platform contents and creates mechanisms to prevent the spreading of unlawful content.

Meanwhile, the **Digital Market Act** (COM-2020-842) seeks to regulate market power based on data that consists of personal data and private sector data held by online platforms and originating from the users (both business and individuals). Thus, the Digital Market Act can intervene in unfair practices by large gate-keeper platforms that companies and consumers face.

Finally, the **Implementing Act on High-Value Datasets** under the **Open Data Directive** (Directive 2019/1024) unleashes the socio-economic potential of high value public sector data as a public good by improving the technical usability of these datasets. In addition, the **Cybersecurity Act** (Regulation 2019/881) strengthens the EU Agency for cybersecurity (ENISA) and establishes a cybersecurity certification framework for products and services. With the **Artificial Intelligence Act** (COM-2021-206), the European Commission puts forward the regulatory framework on artificial intelligence with the following specific objectives: 1) to ensure that AI systems placed on the Union market and used are safe and respect existing law on fundamental rights and Union values; 2) to ensure legal certainty to facilitate investment and innovation in AI; 3) to enhance governance and effective enforcement of existing law on fundamental rights and safety requirements applicable to AI systems; and to 4) facilitate the development of a single market for lawful, safe, and trustworthy AI applications and prevent market fragmentation.

To conclude, the aforementioned set of legal acts provides a framework for resolving various data management challenges. These challenges concern the promotion of a circular economy, but also many other domains in our society. Table 9 depicts how the provisions of the aimed legal acts meet the general data management challenges.

Table 9. Data management challenges and how the European legal acts aim to resolve them.

Data management challenge	Data Governance Act	Digital Market Act	Digital Service Act	Open Data Directive	Impl. Act. High Value Datasets	Data Act	AI Act	Cyber-security Act
Access to data	X			X	X	X		
Awareness of available data sources	X ^a							
Ownership and data control rights	X ^b			X		X ^c		

Data management challenge	Data Governance Act	Digital Market Act	Digital Service Act	Open Data Directive	Impl. Act. High Value Data-sets	Data Act	AI Act	Cyber-security Act
Quality/suitability of available data	X				X		X	
Possibility to share data	X ^{d,e}	X ^f				X		
Possibility to receive and utilize data	X ^d	X ^f	X ^g	X		X		
Trustworthiness of data	X ^h						X	X ⁱ
Lack of system interoperability	X ^j							
Lack of data interoperability	X ^k			X	X			

- a Service Catalogue
- b Data use control mechanisms
- c Ownership of IoT data, IPR of data-bases
- d Marketplace
- e Data altruism
- f Gate keeper obligations
- g Data for authority and research
- h Meta data of datasets
- i Certified digital services
- j Data intermediary services
- k Shared vocabularies, data models

In summary, the EU’s Digital Decade, along with its multiple legal acts, provides a framework and rules for designing activities and businesses for a data-driven circular economy. The legal framework aims to solve diverse obstacles hindering the efficient use of data between ecosystem actors and enhances the implementation of the principles of circular design. **After these reforms, following the principles of a data-driven circular economy will not be a technical challenge but rather a question of motivation within the ecosystem partners.**

4.3.2 Case: Data altruism

Openly sharing data involves risks and expenses. Why would any organisation go to the trouble of adopting common standards that might be inconvenient to live with and provide its data freely for anyone to exploit?

Data altruism refers to the sharing of data voluntarily and freely, for the common good, and is presented in the EU Data Governance Act as an agenda for different actors to participate at. Within the EU, data altruism is seen as a way to support Europe in global competition. Having large amounts of data is an essential part of utilizing methods such as machine learning. In the ever-growing

industry of artificial intelligence and self-learning machines, big data and data pools with high quality, re-usable data may pave the way to new innovations and solutions.

As presented in the EU Data Governance Act, businesses and individuals are encouraged to share their data for the benefit of society. This is supported by establishing a trustworthy framework for sharing data, for example within the common European data spaces, where data is donated to a registered organisation for the common good, i.e., for developing AI solutions. For commercial companies, private and public sector organisations, and other actors that produce data in their processes, participation in the larger data pools requires a certain amount of commitment and effort.

From the circular data perspective, smaller manufacturing companies may see the benefits of data altruism as tempting, but the demands for data sharing efforts as challenging, as their resources might not support their participation in common data pools. **For data altruism to succeed, it could be beneficial to establish national and EU-wide support for small manufacturing companies in their data management.** This would encourage smaller companies to publish their data openly and meet the required standards.

4.3.3 Common European data spaces

One of the key actions in the European strategy for data is the high impact project of creating sector and domain-specific common European data spaces. The reasoning behind the data spaces is phrased in the following way: “For the development of many products and services, data needs to be widely and easily available, easily accessible, and simple to use and process. Data has become a key factor of production, and the value it creates has to be shared back with the entire society participating in providing the data. This is why we need to build a genuine European single market for data – a European data space based on European rules and values.” (European Commission, 2020c).

The Data Governance Act (DGA) creates a legal frame for data spaces and their key elements. One of the key elements defined in the DGA is data intermediary services, neutral services that transfer data between different individual platforms. Individual cloud services and even apps and devices can join the data intermediary services and thus link directly with several other systems in the service.

In the position paper about the principles of data spaces published by the OpenDEI project, a data space is defined as a decentralized infrastructure for trustworthy data sharing and exchange in data ecosystems based on commonly agreed principles (Nagel & Lycklama, 2021). The position paper further claims that European data spaces will basically bring about three new elements:

- **Entirely new services** for users, based on enhanced transparency and data sovereignty;
- **A level playing field for data sharing** and exchange, leading to less dominance of, and dependency on, large, quasi-monopolistic players;

- **A new user behaviour and digital culture**, as users learn to play by the rules and use data (both their own and other users' data) in an ethical way.

According to the European strategy for data (COM-2020-66), there will be a common European data space for the following domains:

- Industry (manufacturing)
- **Green Deal (incl. circular economy)**
- Mobility
- Health
- Finance
- Energy
- Agriculture
- Public administrations
- Skills
- Open science

Data spaces are aimed to be established through public–private partnerships, where the European Commission, Member States, private companies, research organizations, and associations contribute with diverse funding programmes and common development initiatives. Figure 31 illustrates how the development of common European data spaces is supported by various actors, strategies, and development projects.

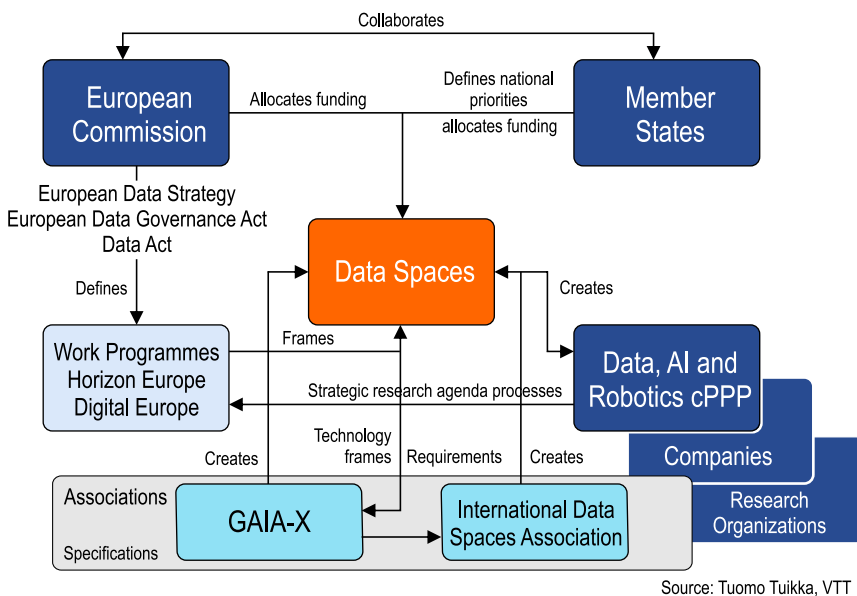

Figure 31. The development of common European data spaces is affected by a myriad of actions. Adapted from an original figure by Tuomo Tuikka (VTT).

From the point of view of a circular economy, the common European Green Deal data space will be of particular interest, providing support for the Green Deal priority actions on climate change, the circular economy, zero pollution, biodiversity, deforestation, and compliance assurance (COM-2020-66). Currently, the initiatives and actions conducted under the Green Deal data space include:

- GreenData4All, which aims at allowing **access to spatial (INSPIRE) and environmental information in the EU** for public authorities, businesses, and citizens
- Rolling out **reusable data services** to collect large volumes of data for **regulatory compliance**
- A European data space for smart circular applications (see Section 4.3.4).
- The **pilot of the zero-pollution ambition**, using already existing data on hazardous chemicals, emissions, etc.
- Destination Earth, which aims to create a very high precision **digital twin of the Earth for forecasting natural and human activity**.

The European Commission aims to invest, together with Member States and businesses, a total of 4–6 billion euros on European data spaces and federated cloud infrastructures (COM-2020-66). Commission will foster synergies between the work on the European cloud federation and Member States' initiatives' such as Gaia-X (COM-2020-66). In Finland, several initiatives have started to work towards data space implementations across domains (LVM, 2021). One of the initiatives is called the Finnish circular economy platform ecosystem, and it is described in more detail in Section 4.4.2.

In summary, an advanced circular economy with a prescriptive approach as well as data-intensive circular design processes will benefit from the development of data spaces, where data also flows between the data spaces of different sectors. **When functioning as expected, data spaces will enable a rich base for data-driven innovations, efficient design, and process optimization.**

4.3.4 European Dataspace for Smart Circular Applications

The establishment of a common European data space for smart circular applications is an initiative under the Common European Green Deal data space. It will provide an architecture and governance for data applications that “enable circular value creations along supply chains.” The focus will be on key value chains of the Circular Economy Action Plan (COM-2020-66; COM-2020-98):

- built environment
- packaging
- textiles
- electronics
- ICT and
- plastics

The circular applications and services under development include digital passports, resource mapping, and consumer information. The plan has been that by 2022, the development process of the European Dataspace for Smart Circular Applications would have covered steps such as the development of architecture and governance, sectoral data strategies, the adoption of a sustainable product policy with product passports and resource mapping, and waste shipments tracking. (COM-2020-66; COM-2020-98) However, the schedule for the establishment of all Common European data spaces appears to be lagging behind (EURACTIV, 2021).

In summary, the **European Dataspace for Smart Circular Applications has ambitious goals to serve as a base layer for product and material traceability, among other targets.** If successful, it seems that it will solve many of the fundamental issues of a data-driven circular economy. However, at the time of writing, the scarcity of information regarding the development of the Smart Circular Applications dataspace hinders making a comprehensive assessment of its scope and significance.

4.3.5 Gaia-X and International Data Spaces (IDS): Two prominent European data-sharing initiatives

Gaia-X is a pan-European project that will build the European data market of the future (BMW, 2020). The project is closely aligned with the European Data Strategy, which aims at creating a genuine digital single market. The Gaia-X project strongly emphasizes European values in building an open ecosystem that defines data

Gaia-X

- Franco-German initiative (introduced in 2019) with close links to the European Commission
- The German Federal Ministry of Economics and Energy (BMW) as a patron
- More than 300 organizations from various countries already involved
- Other countries are invited to join the project
- More than 40 use cases presented from different domains (Industry 4.0/SME, Health, Finance, Public sector, Smart living, Energy, Mobility, and Agriculture)
- Aims at creating a **European federated infrastructure** that creates **trustworthy** service offerings according to clear rules combining centralized and decentralized cloud and edge instances
- Will develop a **reference architecture**, define **standards**, and determine criteria for **certifications** and product quality seals
- The first Gaia-X services will be prototypically implemented by early 2021
- Will work as an enabler of data spaces
- Gaia-X is not a greenfield project – it will **build on existing results and activities** such as IDSA, BDVA, SWIPO, and FIWARE

sharing standards and federated data infrastructure. A non-profit international association, Gaia-X European Association for Data and Cloud AISBL, has been founded to carry out the technical framework and to operate Gaia-X Federation Services (Gaia-X, 2021). An overview of the Gaia-X architecture is presented in Figure 32.

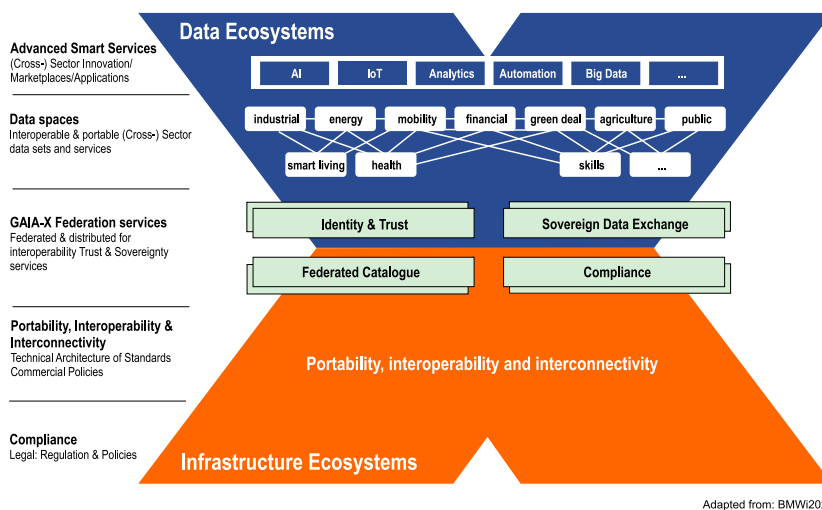

Figure 32. The architectural concept of Gaia-X. Adapted from an original figure by BMWi (BMWi, 2020).

Like Gaia-X, the International Data Spaces Association (IDSA) also has a mission to establish the foundation for the digital economy. The Association’s approach, the International Data Spaces (IDS) initiative, enables secure data exchange with self-determined control of data use, i.e., data sovereignty, by providing services, for example, for data brokering, governance micropayments, and quality scoring. In IDS, certified ecosystem participants can define data usage policies for their data, and a software component called IDS Connector takes care of data and service provisioning.

IDS

- Led by Fraunhofer ISST and promoted by the German Federal Ministry of Education and Research
- Offers a reference architecture sustained by over 100 partners
- The IDS Reference Architecture Model links different cloud platforms through policies and mechanisms for **secure data exchange** and trusted data sharing
- Provides **technical infrastructure** that facilitates contractual agreements on the use of data, for example, for data processing, linkage, analysis, or third-party access
- Parts of the IDS reference architecture have become a formal standard
- A central element of the **Gaia-X** architecture
- IDS research projects demonstrate IDS concepts in real life, and, for example, OPEN DEI <https://www.opendei.eu/> aims at enabling a unified industrial data platform by aligning reference architectures and other initiatives
- IDSA has Hubs in 8 countries for facilitating the adoption of IDS. The **IDSA Hubs** are not-for-profit organizations such as universities or research and technology organizations
- In Finland, the regional IDSA Hub is facilitated by VTT

Gaia-X and IDS very much follow the same vision of proliferating data sovereignty and creating an ecosystem of trust for data sharing. Furthermore, they have a strong architectural connection. IDSA has just recently published a position paper (International Data Spaces Association, 2021a) demonstrating how the principles and architecture elements of these two initiatives fit together. The paper summarizes that “Gaia-X is not as mature as the International Data Spaces (IDS) initiative,” but that “The IDS initiative and IDS Reference Architecture Model (IDS-RAM) offer various concepts and solutions that contribute to the overall vision of Gaia-X and to the concrete Gaia-X architecture demands. On the other hand, Gaia-X provides concepts that include the data storage and cloud-related elements, which can complement the IDS architecture.” This aspect is also depicted in Figure 33.

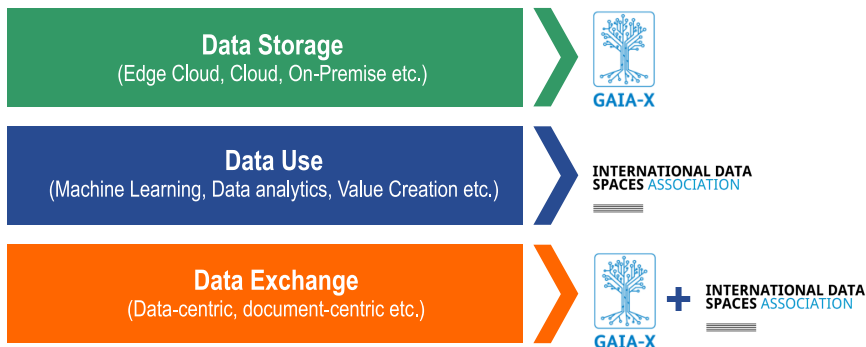

Source: IDSA 2021

Figure 33. Gaia-X and IDS complement each other in ensuring data sovereignty for end-to-end value chains in ecosystems. Adapted from an original figure by International Data Spaces Association (International Data Spaces Association, 2021b)

In summary, Gaia-X and IDS both provide fundamental technical tools and services for secure industrial data sharing. As these projects are being initiated and widely accepted by the industry, they will presumably contribute to the formation of industrial data ecosystems in a considerable way. Furthermore, they will also have a substantial role in the sharing of data for sustainability purposes.

4.4 Implementing and developing a data-driven circular economy in Finland

In Finland, the concept of a circular economy has long been promoted by the Finnish Innovation Fund Sitra, whose work has gained worldwide recognition. Since then, the Finnish Government has taken a more visible role in the policy development. One of the milestones was reached at the beginning of 2021, when the **Government adopted a new strategic programme to promote a circular economy** (Ministry of the Environment, 2021b). The vision of the programme is that in 2035, a carbon-neutral and circular economy will be the foundation of the economy in Finland. Furthermore, the idea is that a “circular economy breakthrough has been made with the help of innovations, digital solutions, smart regulation and responsible investors, companies and consumers” (Ministry of the Environment, 2021b, p. 4). Thus, it is envisioned that multi-stakeholder cooperation and digital solutions will play a key role in the implementation of the programme.

The enactment of the vision will require the sustainable and efficient use of natural resources. **For the first time, the Finnish national circular economy programme features quantitative targets.** These three objectives seek to indicate progress towards a circular economy from different angles (Ministry of the Environment, 2021b, p. 4):

- The consumption of non-renewable natural resources will decrease, and the sustainable use of renewable natural resources may increase to the extent that the total consumption of primary raw materials in Finland in 2035 will not exceed what it was in 2015.
- The profitability of resources will double by 2035 from what it was in 2015.
- The circular economy rate of materials will double by 2035.

The Finnish circular economy programme emphasises the need to highlight the circular economy as the strategic focus of Finland's industrial policy, which aims for sustainable economic growth. In general, **Finland has many strengths for materializing its circular economy vision**, such as advanced product development, ICT know-how, material efficiency, a fruitful operating culture ("thrif in DNA", trust, security), and moderate raw material resources. At the same time, the Finnish challenges appear to be in co-operating, in the creation of end-to-end joint solutions for the global market, and the lack of risk-taking capacity. (Sitra, 2016)

Measures to promote a circular economy have been developed in several national projects (Kautto, et al., 2021; Ruokamo, et al., 2021). **In the Finnish circular economy programme, digitalisation has been included as one of its key drivers**. The main digitalisation proposal of the programme reads as follows (Ministry of the Environment, 2021b, pp. 12-13): "We define, collect and open important data for the circular economy with the support of ongoing platform economy development programmes. We link different sources of information and data important for the circular economy so that by combining data, different actors can lead the circular economy in their own activities, track material data, analyse the impacts of choices, provide circular economy services and create marketplaces. We will open up the authorities' data resources in a safe manner for wider use. We will participate in the Gaia-X project, which aims to create a European data architecture and facilitate the reliable sharing of decentralised data. Finland can be a pioneer by becoming involved in developing and coordinating the architecture applied to the circular economy."

Other key measures of the Finnish circular economy programme include (Ministry of the Environment, 2021b):

- Developing economic incentives that support the sparing use of natural resources, reduce carbon dioxide emissions, and promote the widespread use of circular economy service models.
- Strengthening funding for RDI and ecosystem activities that promote a low-carbon circular economy and for demonstration and facility investments.
- Increasing low-carbon circular economy solutions in such areas as public sector construction, energy and infrastructure projects, and service procurement.
- Improving the effectiveness of funding.
- Influencing the development of legislation and product policy instruments that support the circular economy in the EU.
- Developing cooperation between the authorities in circular economy projects.

- Promoting a stronger market for recycled materials.
- Helping citizens find circular economy services and improving their appeal.
- Signing an agreement on a low-carbon circular economy.
- Establishing a 'national competence network' to support the work of municipalities and regional ecosystems in promoting a carbon-neutral circular economy society.
- Increasing circular economy awareness and expertise in the real estate and construction sector.
- Developing the principles of land use planning and the steering of construction and use of facilities to support the circular economy.
- Launching and promoting circular economy ecosystems.
- Creating a circular economy design programme.
- Including circular economy competence as part of the education system and working life competence.
- Promoting a global transition to the circular economy.
- Developing an orchestration model to accelerate the export of Finnish circular economy solutions.

In Finland, the Ministry of Economic Affairs and Employment is coordinating the implementation of the digitalisation targets and measures of the national circular economy programme. It is cooperating with the Circular Design Network Project and has also kick-started a new project with Motiva Services that, among other activities, will map the state of digitalisation in the circular economy and analyse possible models for the digitalisation of circular economy accelerators.

Meanwhile, major European data and digitalisation initiatives are being implemented in Finland under the lead of the Ministry of Finance and the Ministry of Transport and Communications. As regards the implementation of the EU digitalisation initiatives, the Data Governance Act and Data Act are both topical pieces of regulation. Of these Acts, the Data Governance Act has already been agreed by the European Council and the European Parliament. In Finland, the implementation of the Data Governance Act will mean the establishment of **a single national information point to support the reuse of public sector data and a register of data resources under its umbrella.**

The idea is that the already existing data management map of the public administration (Julkisen hallinnon tiedonhallintakartta) will act as a basis for the register. In general, the Data Governance Act creates common principles for the reuse of data, for example for the processing of data in safe environments and for making it anonymous. Thus, it does not directly open new data but enables its better use. Nevertheless, major changes in the current Finnish conduct could be brought about, for instance, by the idea of the Data Governance Act that **further specialist support and assistance should be available for the establishment of safe digital environments.** The implementation of this idea is, however, still unclear.

Meanwhile, the new Data Act is expected to bring fair rules for data access. A fair data economy is also one of current development spearheads of Sitra, and it provides a home organisation for the recently launched Gaia-X hub of Finland. **In**

general, involvement in the formation of the EU's new data infrastructure is considered important in Finland, and participation in the IDS and Gaia-X initiatives has thus been active. Some actions related to these include the following:

- The Ministry of Employment and the Economy, Business Finland, and VTT have explored in the close co-operation the possibilities for Finnish actors to participate in the Gaia-X initiative.
- The PREGAIA project was carried out as a preparatory project primarily for participating in the Gaia-X definition work.
- VTT coordinates the Finnish IDSA Hub.
- Motiva plans to build a circular economy-related use case in Gaia-X.

When trying to encapsulate the state of governance efforts towards a data-driven circular economy in Finland, the picture is as versatile and turbulent as in the EU in general. This can also be easily recognised when reading Finland's circular economy programme and comparing the digitalisation section, for example, with the section that deals with the promotion of a circular economy in municipalities: As regards municipalities, there seems to be a relatively clear picture on the ways in which a circular economy can be integrated in the strategic management of municipalities, what the key challenges are, and what could be potential tools for development. Meanwhile, the digitalisation section of Finland's circular economy programme deals with the challenges and solutions on a relatively abstract level, and the solutions provided are somewhat piecemeal or sporadic compared to the big picture. (Valtioneuvosto, 2021; Hildén, et al., 2021)

At the same time, **Finland has several assets to act as an international pioneer in the field.** From the governance perspective, the assets include a background in reformative and holistic legislative efforts such as the Act on Transport Services, which has given rise to MaaS solutions (see Section 4.4.1), and a fruitful operating culture that nurtures trust and security. In addition, there is the global reputation of Finland as an ICT country and as a pioneer in the circular economy (Sitra, 2016). Thus, while it can be concluded that the field of a data-driven circular economy is far from easy and clear, there is a general hegemony about the need to develop it and positive pressure to show the way for others.

In summary, implementing major EU initiatives on data and the circular economy is already changing the operational environment for a data-driven circular economy in Finland. At the same time, Finland has adopted a rather ambitious and broad circular economy programme that is accelerating various national circular economy initiatives. In the forthcoming sections, we describe the concrete cases that have already been implemented in Finland. These include the aforementioned MaaS and the Platform ecosystem for a circular economy (see Section 4.4.2). In addition, in Section 4.4.3 we shed further light on a sector that is of key importance for a well-functioning circular economy but that has been overshadowed by other themes in this report: the built environment. The circular economy and data initiatives of the

built environment both in Finland and in the EU will be discussed, with emphasis on those initiatives that combine both aspects of the twin transition in depth.

4.4.1 Case: Pioneering regulatory framework accelerated MaaS

The development of mobility-as-a-service (MaaS) concepts in Finland is a primary example of the potential role that successful governance efforts can play in enabling data-driven circular solutions. The pioneering national legislation, the Act on Transport Services (Act on Transport Services 320/2017), imposes the disclosure of essential information from mobility service providers via an open interface. The obligations aim at promoting digitalisation and enabling the development of mobility services. Data to be submitted include ticket prices, payment methods, routes, and schedules. (Traficom, 2021) The information is submitted to the Finnish national open transport service catalogue (NAP), which is free of registration for service developers, who benefit from open information when developing journey planners and new transport services (NAP, 2021).

Already in 2015, the City of Helsinki identified the importance of MaaS in promoting a functioning transport system and raised it as one of the priorities in the city's mobility plan (City of Helsinki, 2015). The importance of new services and technologies was further emphasised in 2019 in the strategic land use, housing, and transport plan for the Helsinki region (HSL, 2019). Helsinki has also performed highly, for example, in the Deloitte City Mobility Index (Deloitte, 2019).

The best-known MaaS application in Finland is probably Whim, which was developed by Finnish-based MaaS Global, the world's first MaaS operator. Whim combines public and private transport options into one app. The service is based on a seasonal subscription or one-time fee. (Whim, 2021)

MaaS is a good example, as it demonstrates the contradiction of quick and slow paces of development in a data-based circular economy. While Finland, indeed, pioneers in MaaS, and not only in governance but also in business development, **there have also been critical voices in the MaaS discussion.** First of all, opening of the data has not proceeded at the pace required by the Act on Transport Services. In addition, it has proven difficult to make Whim economically viable, despite substantial investments poured into the company behind it (Helsingin Sanomat, 2021).

4.4.2 Platform ecosystem for a circular economy connects platforms, marketplaces, and networks

The development work for the Finnish circular economy platform ecosystem was launched in autumn 2020. **The objective of the circular economy platform ecosystem is to build interoperability between industries and to optimize material use.** In short, the circular economy platform ecosystem aims at:

- collecting, harmonizing, and enriching data for circular material flows across industries
- combining circular demand and supply

- combining services to support material circulation
- connecting data platforms and marketplaces across industries so that the materials find optimal use from both ecological and financial perspectives. (Motiva Oy, 2021)

The circular economy platform ecosystem will serve a wide range of actors: material producers, users, and processors, as well as service providers, developer partners, and other platforms. It will also enable connecting data from private and public information systems, making information from different sources more widely available, and thus also promoting the visibility and use of ecosystem-connected platforms and marketplaces. (Motiva Oy, 2021) When building the platform, it will utilize international standards and architectures, such as those drawn from the Gaia-X.

At first, the development work will focus on the built environment. However, the vision is that in the future, the circular economy platform ecosystem will be “the most widely used solution for the maximal use of side streams and the waste materials of companies and communities, regardless of sector” (Sitra, 2021b). Motiva has developed the concept for the platform and is developing it further in regional pilot projects in collaboration with different actors. (Motiva Oy, 2021)

An example of a service that will be integrated in the Platform ecosystem is Materiaalitori. **Materiaalitori is a data platform intended for the professional exchange of waste and production side streams from companies and organizations** (Materiaalitori, 2021; Motiva Oy, 2021). The use of Materiaalitori is obligated in the Waste Act (Waste Act 646/2011) in a case when a business or organization is in a need of municipal supplementary waste management services with a value of 2000 euros or more per year. In this case, the waste holder is obliged to primarily search for a suitable, market-based service in Materiaalitori. If a suitable service is not found within 14 days, the waste holder may request a municipal supplementary waste management service. The platform brings transparency to this process. It is also used for the management and processing of information on the municipal supplementary waste management service, as well as monitoring the service.

Materiaalitori is open and free of charge for all waste, side stream, and waste service providers and needers. Motiva and the Ministry of the Environment will together develop the content and functionality of Materiaalitori. (Motiva Oy, 2021) **From a data-based circular economy and governance point of view, Materiaalitori provides another key example, as it shows how a legal act can enhance openness and the availability of data.**

4.4.3 Case: Built environment – making the data to serve a circular economy

The material and energy-intensive built environment has a major role in the sustainability transition in the EU. For construction, a very important transition driver will be the EU Taxonomy, but several other measures are also presented in various

EU strategies. Controlling wastes and optimizing material use in construction and renovation, as well as energy consumption throughout the life cycle of buildings, are some of the key actions. The EU has recognized the importance of promoting a circular economy in achieving the green goals, and digitalization has an important role to play in it.

The initiative for a strategy for a sustainable built environment was launched in both the CEAP and Industrial Strategy under the Green Deal. The digital solutions promoting a circular economy in the strategy will involve, for example, increasing the use of a new Level(s) tool, which sets the framework for sustainable buildings (European Commission, 2021c). The strategy for a sustainable built environment is expected to be launched in 2021–2022 (European Parliament, 2021).

In the communication “A Renovation Wave for Europe” (COM-2020-662), utilizing digital solutions such as a digital twin of a building and a Building Information Model (BIM) are recommended, as, for example, they provide information on the performance of a building, improve transparency, and allow cost savings from accelerated administrative procedures. The Renovation Wave presents several digitality promoting initiatives:

- **Update on the energy performance certificates (EPC) framework**, including “looking at uniform EU machine-readable data format for the certificates and more stringent provisions on availability and accessibility of databases and federated digital repositories for EPCs.”
- **Digital Building Logbooks** that will store all building-related data in a compatible and integrated way. Data will be compiled from sources such as Building Renovation Passports, Smart Readiness Indicators, Level(s), and EPCs.
- **The support of the Commission on digitalization in the construction sector** through Horizon Europe, Digital Innovation Hubs, and Testing and Experimentation Facilities.
- **A consideration on setting a governance framework for data spaces** with further actions to develop allocated data spaces, including in the areas of energy, manufacturing, and construction.
- **A recommendation to promote the Building Information Model (BIM) in public procurement** for construction and provide a methodology to public clients to conduct cost–benefit analysis for the use of the BIM in public tenders.
- **The development of a unified EU Framework for digital permitting** in the built environment and establishment of a trusted scheme for certifying energy efficiency meters in buildings that can measure actual energy performance improvements.

In Finland, both the Government Programme and the strategic programme to promote a circular economy encourage the introduction of circular economy

measures, low-carbon construction, and the promotion of digitalization in the construction industry. Promoting digitalisation is also one of the key objectives in the reform of the Land Use and Building Act that is underway. The act will define the information that needs to be obtained in a digital form in the future. (Ministry of the Environment, 2021c)

The Ryhti project of the Ministry of the Environment was launched for the digitalization process of the built environment. The four-year project will compile information on building and land use in a new built environment information system (RYTJ). (Ministry of the Environment, 2021c) A more comprehensive description of RYTJ is provided in Appendix A, Section 6.1

The Ministry of the Environment has also published a three-stage roadmap for low-carbon construction. According to the roadmap, the carbon footprint of a building during its life cycle will be regulated by legislation by the mid-2020s. (Ministry of the Environment, 2021d)

The construction sector in Finland has been active and anticipated the forthcoming EU and national requirements regarding the circular economy and climate targets. Data utilisation with digital tools is becoming increasingly common. With the help of the data, planning, construction, and maintenance will become more efficient. Platforms for demolition materials and side streams are also under development. These include the Platform ecosystem for a circular economy and Materiaalitori discussed in Section 4.4.2.

4.5 Conclusions: lessons for future governance efforts to promote a data-driven circular economy in Finland

In the previous sections, we have sought to map some of the most important governance drivers for a data-based circular economy and to analyse them. The analysis has been somewhat superficial, since many of the initiatives are broad and/or works in progress. However, in this section, we try to draw some conclusions and lessons for future policy development in Finland.

Table 10 paints the big picture of the field by presenting a 4Is analysis (Brockhaus & Angelsen, 2012) on the governance challenges and opportunities of a data-driven circular economy in Finland and the EU. **The 4Is framework** covers ideas, information, interests, and institutions. According to the model, *ideas* describe how an idea, such as a data-driven circular economy, is understood and discussed. Ideas can arise from societal discourses, ideologies, and beliefs. In this context, an idea can be, for example, that a data-driven circular economy is a desirable societal goal, but difficult to achieve. Meanwhile, *information* includes data and knowledge, how they are formed and used, and by whom in political and economic decision-making. In this case, information would cover, for example, reliable knowledge about the key challenges and solutions that would drive a data-based circular economy in different contexts. While both ideas and information are related to knowledge, *interests* refer to actors in the policy field and their potential material benefits. Thus, the interests of various stakeholders may heavily influence the type

of policy that is being promoted. And finally, *institutions* entail formal and informal institutional arrangements, such as various acts, political strategies, or networks – but also path dependencies that can form potential resistance to change (Brockhaus & Angelsen, 2012).

Table 10. *4Is analysis on the challenges and opportunities of governing a data-driven circular economy in Finland and the EU.*

4Is	Opportunities	Challenges
Ideas	The general idea about promoting a data-driven circular economy is widely supported.	Ideas about a future data-driven circular economy are somewhat blurry and siloed. In particular, ideas about how to get to such a future in a swift, fair, and strategic manner are scarce. For example, only a few experts have clear ideas about the initiatives and experiments that Finland should drive forward when a data-driven circular economy is being promoted particularly in Europe.
Information	An increasing amount of information relevant for proceeding towards a real circular economy is available, and, for example, initiatives such as the EU Green Deal and the EU Taxonomy can be used for increasing not only the availability and quality of information, but also its use in key decision-making processes.	Knowledge about the various challenges and the potential solutions is scattered. It is difficult to assess which of them are more important than the others. Furthermore, many of the already existing solutions are poorly known. For example, the potential of tracing technologies is not fully utilised. There are major needs for co-creative R&D&I work.
Interests	There are no major politized contradictions in the field.	In practice, there are, however, a lot of minor unsolved conflicts of interest as regards, for example, the sharing of the benefits of opening privately owned data. As the technological opportunities for sharing, enhancing, and using data could be better utilised to drive a circular economy, there is a need for clear incentives.
Institutions	There is a wide array of initiatives that, for example, the EU has put forward in order to promote the twin transition and also a data-driven circular economy.	From many perspectives, missing institutional arrangements such as incentives and infrastructures for producing, sharing, quality- proofing, and using data are the main obstacle for proceeding towards a data-driven circular economy. However, initiatives such as the EU Taxonomy can act as quick game-changer, particularly in fields where methodologies and technologies are relatively well-developed, such as in many low-carbon solutions. In addition, it will be interesting to see how entities such as the European Dataspace for Smart Circular Applications develop, and which actors will have key roles, power, and responsibilities in the development processes.

When seeking to understand the dynamics of policy development towards a data-driven circular economy, **a key aspect is to trace the ways in which top-down and bottom-up initiatives interact.** For example, the development of European data spaces and initiatives such as Gaia-X and IDS provide shared vocabulary, architecture, and components for solutions on all levels and in all sectors. Thus, these initiatives, as well as tools and technologies such as blockchain, can provide opportunities for data sharing and use on international, national, and local levels – in both public and private sectors. It would be important to ensure high quality implementation of the key top-down initiatives and to broadly scale up the most promising bottom-up cases.

From a circular economy point of view, one of the core aspects is to affect the environmental footprint of products and services along their life cycles, and the environmental burden of our production and consumption systems more generally (Berg, et al., 2018). An interesting concept in this context is also the environmental handprint, i.e., how to increase the beneficial impacts created within the life cycle of products and services (Norris, 2015; Behm, et al., 2016). However, not only those initiatives that take place within resource-intensive sectors such as construction or manufacture, or within specific product life cycles, but also those that can change systems and practices more broadly are critical. Hence, **when prioritising actions, it is important to estimate the potential they have to cut emissions and improve circularity on large scale,** alongside the economics associated with them. The idea is to prioritise those actions that have the largest benefits at the cheapest cost and are preferably also quick to implement. For example, marginal abatement cost curves (McKinsey, 2009; Farbes, Haley, & Jones, 2020) have been constructed to compare various solutions based on abatement and cost criteria. The presented methodologies are all sensitive to changes in the underlying assumptions, such as technological advances, new actors, or altered market frameworks (e.g., EU Taxonomy), which may change the rules of the game.

What does this mean for a country such as Finland that has chosen (Ministry of the Environment, 2021b) to proceed towards a data-driven circular economy? How should it develop its national strategy now and in the near future? In this report, we have mapped many key European and national initiatives that support the digital and circular twin transition and also sought to understand the dynamics of the field. **The next step would be to define practical, national development priorities among the key stakeholders.** What type of R&D&I work will be supported? Will there be national steering mechanisms of some kind, such as new financial incentives, voluntary agreements, or regulations, that support this work? **When seeking to select the right measures, it would be useful to have a framework to evaluate them even on a rough scale.** For the moment, no ready-made tool is available, but inspiration could be drawn, for example, from:

- The lists of barriers to a circular economy (Bakajic & Parvi, 2018): Do the measures chosen solve some of the key challenges?

- The indicators of the circular economy (Alaerts, et al., 2019): How do the measures contribute to the state of art as shown by the metrics?
- The depth or smartness of change (ECERA European Circular Economy Research Alliance, 2020): How superficial or fundamental will the change towards a circular economy be, and will it be based on merely descriptive data or a systemic view?

In a nutshell, the lessons for practical policy-making are the following:

- **The twin transition towards digitalisation and sustainability should really be synergetic.** In other cases, there is a risk of, for example, bad investments or detrimental future lock-ins (Berg, et al., 2021; Hedberg & Šipka, 2020).
- Grasping the big picture of the state of art of a data-driven circular economy is difficult and easily becomes outdated. Therefore, **a national governance process seeking to promote it should be agile** (Berg, et al., 2021). Rather than formulating a perfect implementation roadmap for the next decade, it should include **frequent scanning of the field and involve a network of key actors**. It is not only important to scan the developments taking place in Finland, but particularly on the EU level. As has been shown, several EU-level drivers may substantially speed up the uptake and development of a circular economy and, for example, relevant data management systems in companies.
- When **setting development priorities**, an idea could be to prioritise those initiatives that address the most material-intensive sectors, such as construction, or sectors that use critical raw materials, such as ICT. Many of these sectors have also been discussed in this report. It would also be important to take part in the cross-cutting international development efforts such as Gaia-X. Furthermore, it would be important to get the **economic incentives** to work for a data-driven circular economy. Initiatives such as the Taxonomy Regulation can provide an important tool for this, but development work and policy reforms will also be needed in various other realms.
- The network of key actors in the field of a data-driven circular economy could also kick-start **joint projects and apply for international R&D&I funding**, such as Horizon money.
- The actors of the central government could ensure a fruitful regulatory environment and **encourage experimentation by providing, for example, opportunities for R&D&I work, funding, or regulatory sandboxes**.
- **Measurement methods, standards, and indicators** for a circular economy are from many perspectives underdeveloped compared, for example, to those of climate change mitigation. Thus, research institutes could pay special attention to them, and R&D&I financiers could ensure that resources are available for this development.

Acknowledgements

The authors would like to thank the numerous experts who, in addition to those listed as authors, took part in the preparation of this report. We also would like to thank Dr Patrick Friedrichs for his review of the report and the Academy of Finland for financial support for the CircDNet project (grant n:o 337713).

References

- Act on the Openness of Government Activities 621/1999. (1999). Retrieved from <https://finlex.fi/fi/laki/ajantasa/1999/19990621>
- Act on Transport Services 320/2017. (2017). Act on Transport Services 320/2017. Retrieved from <https://www.finlex.fi/en/laki/kaannokset/2017/en20170320>
- Akkukierrätys Pb Oy. (2021). Akkukierrätys Pb Oy. Retrieved from <https://www.akkukierratyspb.fi/akkukierratys-pb-oy/>
- Alaerts, L., Acker, K., Rousseau, S., De Jaeger, S., Moraga, G., Dewulf, J., De Meester, S., Passel, S., Compernelle, T., Bachus, K., Vrancken, K. & Eyckmans, J. (2019). Towards a more direct policy feedback in circular economy monitoring via a societal needs perspective. *Resources, Conservation and Recycling*, 149, 363-371. doi:<https://doi.org/10.1016/j.resconrec.2019.06.004>
- Alakangas, E., Junginger, M., van Dam, J., Hinge, J., Keränen, J., Olsson, O., Porsö, C., Martikainen, A., Rathbauer, J., Sulzbacher, L., Vesterinen, P. & Vinterbäck, J. (2012, 8). EUBIONET III—Solutions to biomass trade and market barriers. *Renewable and Sustainable Energy Reviews*, 16(6).
- Alakangas, E., Nikolaisen, L., Sikkema, R. & Junginger, M. (2011). Combined Nomenclatures (CN Codes) for Biomass Fuels. VTT-R-03873-1. Retrieved from https://www.vttresearch.com/sites/default/files/julkaisut/muut/2011/D2-4-EUBIONETIII_CN_code_report.pdf
- Alamerew, Y., Kambanou, M., Sakao, T. & Brissaud, D. (2020). A Multi-Criteria Evaluation Method of Product-Level Circularity Strategies. *Sustainability* (12), 5129. doi:10.3390/su12125129
- Askoxylakis, I., Alexandris, G. & Demetriou, G. (2017). Block-chain-enabled Intelligent Asset Exchange for a Circular Economy. *Block-chain Engineering*, 27.
- Bakajic, M. & Parvi, A. (2018). Barriers to Closing Waste Loops in the European Union - Implications for circular economy platforms in waste management. Aalto University School of Business, Information and Service Management. Aalto University. doi:10.13140/RG.2.2.17952.43528
- Bakker, C., den Hollander, M., van Hinte, E. & Zijlstra, Y. (2014). Products that Last: Product Design for Circular Business Models. TUDelft library.

- Bakshan, A., Srour, I., Chehab, G., El-Fadel, M. & Karaziwan, J. (2017). Behavioral determinants towards enhancing construction waste management: A Bayesian Network analysis.". *Resources, Conservation and Recycling* (117), 274–284.
- Bär, H. & Schrems, I. (2021). Introduction to the EU Taxonomy for a Circular Economy. *Forum Ökologisch-Soziale Marktwirtschaft (FÖS)*.
- Baumann, H. & Tillman, A.-M. (2004). *The Hitch Hiker's Guide to LCA. An orientation in LCA methodology and application.*
- Behm, K., Husgafvel, R., Hohenthal, C., Pihkola, H. & Vatanen, S. (2016). Carbon handprint – communicating the good we do. Espoo: VTT Technical Research Centre of Finland. Retrieved from <http://www.vtt.fi/inf/julkaisut/muut/2016/VTT-R-00452-16.pdf>
- Benoît-Norris, C., Vickery-Niederman, G. & Valdivia, S. (2011). Introducing the UNEP/SETAC methodological sheets for subcategories of social LCA. *Int J Life Cycle Assess*, 16, 682–690. doi:<https://doi.org/10.1007/s11367-011-0301-y>
- Berg, A., Antikainen, R., Hartikainen, E., Kauppi, S., Kautto, P., Lazarevic, D., Piesik, S. & Saikku, L. (2018). *Circular Economy for Sustainable Development.* Finnish Environment Institute. Retrieved from <http://hdl.handle.net/10138/251516>
- Berg, H., Bendix, P., Jansen, M., Le Blévenec, K., Bottermann, P., Magnus-Melgar, M., Pohjalainen, E. & Wahlström, M. (2021). *Unlocking the potential of Industry 4.0 to reduce the environmental impact of production.* European Environment Agency, European Topic Centre on Waste and Materials.
- BIO Intelligence Service. (2013). *Material-efficiency Ecodesign Report and Module to the Methodology for the Ecodesign of Energy-related Products (MEErP), Part 1: Material Efficiency for Ecodesign – Draft Final Report.* Prepared for: European Commission - DG Enterprise and Industry.
- Blomberg, K. & Toivikko, S. (2015). *Puhdistamolietteiden käsittely ja hyödyntäminen - Kyselyn tulokset 2015.* Helsinki: Suomen Vesilaitosyhdistys ry.
- BMWi. (2020). *GAIA-X: The European project kicks off the next phase.* Berlin: Federal Ministry for Economic Affairs and Energy (BMWi) Public Relations. Retrieved from https://www.data-infrastructure.eu/GAIA-X/Redaktion/EN/Publications/gaia-x-the-european-project-kicks-of-the-next-phase.pdf?__blob=publicationFile&v=7

- Bocken, N. M., de Pauw, I., Bakker, C. & van der Grinten, B. (2016). Product design and business model strategies for a circular economy. *Journal of Industrial and Production Engineering* (33), 308–320. doi:<https://doi.org/10.1080/21681015.2016.1172124>
- Bocken, N. & Antikainen, M. (2018). Circular Business Model Experimentation: Concept and Approaches. In D. Dao, R. Howlett, R. Setchi, & L. Vlacic, *Sustainable Design and Manufacturing*. Springer International Publishing. doi:https://doi.org/10.1007/978-3-030-04290-5_25
- Bocken, N. & Ritala, P. (2021). Six ways to build circular business models. *Journal of Business Strategy*, 8. doi:<https://doi.org/10.1108/JBS-11-2020-0258>
- Brockhaus, M. & Angelsen, A. (2012). Seeing REDD+ through 4Is: A political economy framework. In A. Angelsen, M. Brockhaus, W. Sunderlin, & L. Verchot, *Analysing REDD+: Challenges and choices*. Bogor: Center for International Forestry Research (CIFOR).
- Çambaşı, H., Kuru, Ö., Amasyalı, M. F. & Tahar, S. (2019). Comparison of Dynamic Bayesian Network Tools. *Innovations in Intelligent Systems and Applications Conference (ASYU)*, (pp. 1–6). doi:doi:10.1109/ASYU48272.2019.8946390.
- CE-IoT. (2021). CE-IoT. Retrieved from A Framework for Pairing Circular Economy and IoT.: <https://www.ce-iot.eu/>
- CGRi. (2021). Circularity Gap Report. Retrieved from <https://www.circularity-gap.world/2021>
- Choudhury, O. (2019). "Differential privacy-enabled federated learning for sensitive health data." arXiv preprint arXiv:1910.02578.
- City of Helsinki. (2015). Helsingin kaupunkisuunnitteluviraston liikennesuunnitteluosaston selvityksiä 2015:4. Retrieved from https://www.hel.fi/hel2/ksv/julkaisut/los_2015-4.pdf
- Colebatch, H. (2014). Making sense of governance. *Policy and Society*, 33, 307–316. doi:<https://doi.org/10.1016/j.polsoc.2014.10.001>
- COM-2018-97. (2018). Action Plan: Financing Sustainable Growth. COM/2018/97 final. Brussels, 8.3.2018. Communication from the Commission to the European Parliament, The European Council, The Council, The European Central Bank, The European Economic and Social Committee and the Committee of the Regions. Retrieved from <https://ec.europa.eu/transparency/regdoc/rep/1/2018/EN/COM-2018-97-F1-EN-MAIN-PART-1.PDF>

- COM-2019-640. (2019). The European Green Deal. COM/2019/640 final. Brussels, 11.12.2019. Communication from the Commission to the European Parliament, The European Council, The Council, The European Economic and Social Committee and The Committee of the Regions. Retrieved from https://ec.europa.eu/info/sites/info/files/european-green-deal-communication_en.pdf
- COM-2020-102. (2020). A New Industrial Strategy for Europe. COM/2020/102 final. Brussels, 10.3.2020. Communication from the Commission to the European Parliament, The Council, The European Economic and Social Committee and the Committee of the Regions. Retrieved from <https://eur-lex.europa.eu/legal-content/EN/TXT/?uri=CELEX:52020DC0102>
- COM-2020-381. (2020). A Farm to Fork Strategy for a fair, healthy and environmentally-friendly food system. COM/2020/ 381 final. Brussels, 20.5.2020. Communication from the Commission to the European Parliament, The Council, The European Economic and Social Committee and the Committee of the Regions. Retrieved from <https://eur-lex.europa.eu/legal-content/EN/TXT/?uri=CELEX:52020DC0381>
- COM-2020-65. (2020). WHITE PAPER On Artificial Intelligence - A European approach to excellence and trust. Brussels. Retrieved from <https://eur-lex.europa.eu/legal-content/EN/TXT/?uri=COM:2020:65:FIN>
- COM-2020-66. (2020). A European strategy for data. COM/2020/66 final. 19.2.2020. Communication from the Commission to the European Parliament, The Council, The European Economic and Social Committee and the Committee of the Regions. Retrieved from https://ec.europa.eu/info/sites/info/files/communication-european-strategy-data-19feb2020_en.pdf
- COM-2020-662. (2020). A Renovation Wave for Europe - greening our buildings, creating jobs, improving lives. COM/2020/662 final. Brussels 14.10.2020. Communication from the Commission to the European Parliament, The Council, The European Economic and Social Committee and the Committee of the Regions. Retrieved from <https://eur-lex.europa.eu/legal-content/EN/TXT/?uri=CELEX:52020DC0662>.
- COM-2020-667. (2020, October 14). Chemicals Strategy for Sustainability Towards a Toxic-Free Environment. Communication from the Commission to the European Parliament, The Council, The European Economic and Social Committee and the Committee of the Regions., Brussels. Retrieved from <https://eur-lex.europa.eu/legal-content/EN/TXT/?uri=COM:2020:667:FIN>
- COM-2020-67. (2020). Shaping Europe's digital future. COM/2020/67 final. Brussels, 19.2.2020. Communication from the Commission to the

European Parliament, The Council, The European Economic and Social Committee and the Committee of the Regions. Retrieved from <https://eur-lex.europa.eu/legal-content/en/TXT/?uri=CELEX:52020DC0067>

COM-2020-767. (2020). Proposal for a Regulation of the European Parliament and of the Council on European data governance (Data Governance Act). Brussels. Retrieved from <https://eur-lex.europa.eu/legal-content/EN/TXT/?uri=CELEX%3A52020PC0767>

COM-2020-798. (2020). Proposal for a Regulation of The European Parliament and of The Council concerning batteries and waste batteries, repealing Directive 2006/66/EC and amending Regulation (EU) No 2019/1020. COM/2020/798 final. Brussels, 10.12.2020. Retrieved from <https://eur-lex.europa.eu/legal-content/EN/TXT/?uri=CELEX:52020PC0798>

COM-2020-825. (2020, December 15). Proposal for a Regulation of the European Parliament and of the Council on a Single Market for Digital Services (Digital Services Act) and amending Directive 2000/31/EC. Retrieved from <https://eur-lex.europa.eu/legal-content/en/TXT/?uri=COM%3A2020%3A825%3AFIN>

COM-2020-842. (2020, December 15). Proposal for a Regulation of the European Parliament and of the Council on contestable and fair markets in the digital sector (Digital Markets Act). Brussels. Retrieved from <https://eur-lex.europa.eu/legal-content/en/TXT/?uri=COM%3A2020%3A842%3AFIN>

COM-2020-98. (2020). A new Circular Economy Action Plan. For a cleaner and more competitive Europe. COM/2020/98 final. Brussels, 11.3.2020. Communication from the Commission to the European Parliament, The Council, The European Economic and Social Committee and the Committee of the Regions. Retrieved from <https://eur-lex.europa.eu/legal-content/EN/TXT/?uri=COM:2020:98:FIN>

COM-2021-206. (2021, April 21). Proposal for a Regulation of the European Parliament and of the Council Laying Down Harmonised Rules on Artificial Intelligence (Artificial Intelligence Act) and Amending Certain Union Legislative Acts. Brussels. Retrieved from https://eur-lex.europa.eu/resource.html?uri=cellar:e0649735-a372-11eb-9585-01aa75ed71a1.0001.02/DOC_1&format=PDF

CRIRSCO. (2013). International Reporting Template for the Public Reporting of Exploration Results, Mineral Resources and Mineral Reserves. Retrieved from www.crirSCO.com.

- Dahlbo, H., Aalto, K., Eskelinen, H. & Salmenperä, H. (2017). Increasing textile circulation - consequences and requirements. *Sustain Prod and Consum* (9), 44–57. doi:10.1016/j.spc.2016.06.005
- Dahlbo, H., Aalto, K., Salmenperä, H., Eskelinen, H., Pennanen, J., Sippola, K. & Huopalainen, M. (2015). Tekstiilien uudelleenkäytön ja tekstiilijätteen kierrätyksen tehostaminen Suomessa. (4).
- D'Amato, D., Droste, N., Allen, B., Kettunen, M., Lähtinen, K., Korhonen, J., Leskinen, P., Matthies, B. & Toppinen, A. (2017). Green, circular, bio economy: A comparative analysis of sustainability avenues. *Journal of Cleaner Production* (168), 716–734.
- De Angelis, R., Howard, M. & Miemczyk, J. (2018). Supply chain management and the circular economy: Towards the circular supply chain. *Production Planning & Control* (29), 425–437. doi:https://doi.org/10.1080/09537287.2018.1449244
- Deloitte. (2019). Deloitte City Mobility Index Helsinki. Deloitte insights. Retrieved from https://www2.deloitte.com/content/dam/insights/us/articles/4331_Deloitte-City-Mobility-Index/Helsinki_GlobalCityMobility_WEB.pdf
- den Hollander, M. C., Bakker, C. A. & Hultink, E. J. (2017). Product Design in a Circular Economy: Development of a Typology of Key Concepts and Terms. *Journal of Industrial Ecology* (21), 517–525.
- Di Cesare, S., Silveri, F. & Sala, S. (2018). Positive impacts in social life cycle assessment: state of the art and the way forward. *Int J Life Cycle Assess* (23), 406–421. doi:10.1007/s11367-016-1169-7
- Digital and Population Data Services Agency. (2021). Avoindata.fi. Retrieved 12 27, 2021, from <https://www.avoindata.fi/fi/opas/mita-on-avoin-data>
- Directive (EU) 2016/943. (2016, June 8). Directive (EU) 2016/943 of the European Parliament and of the Council on the protection of undisclosed know-how and business information (trade secrets) against their unlawful acquisition, use and disclosure. *Official Journal of the European Union*, 157, 1–18. Retrieved from <https://eur-lex.europa.eu/legal-content/EN/TXT/?uri=CELEX:32016L0943>
- Directive (EU) 2019/1024. (2019, June 20). Directive (EU) 2019/1024 of the European Parliament and of the Council on open data and the re-use of public sector information. Retrieved from https://eur-lex.europa.eu/legal-content/EN/TXT/?uri=uriserv:OJ.L_.2019.172.01.0056.01.ENG

- Directive 2005/32/EC. (2005, July 22). Directive 2005/32/EC of the European Parliament and of the Council establishing a framework for the setting of ecodesign requirements for energy-using products and amending Council Directive 92/42/EEC and Directives 96/57/EC and 2000/55/EC. Official Journal of the European Union, 191, 29–58. Retrieved from <https://eur-lex.europa.eu/legal-content/en/ALL/?uri=CELEX:32005L0032>
- Directive 2009/125/EC. (2009, October 31). Directive 2009/125/EC of the European Parliament and of the Council establishing a framework for the setting of ecodesign requirements for energy-related products. Official Journal of the European Union, 285, 10–35. Retrieved from <https://eur-lex.europa.eu/legal-content/EN/ALL/?uri=celex:32009L0125>
- Directive 96/9/EC. (1996, March 27). Directive 96/9/EC of the European Parliament and of the Council of 11 March 1996 on the legal protection of databases. Official Journal of the European Communities, 77, 20–28. Retrieved from <https://eur-lex.europa.eu/legal-content/EN/TXT/?uri=celex:31996L0009>
- Domenech, T., Ekins, P., van Ewijk, S., Klein, S., Kloss, B., Miedzinski, M., Petit, M., Stuchtey, M. & Tomej, J. (2019). Making Materials Work for Life – Introducing Producer Ownership. Project Launch. Retrieved from <https://www.systemiq.earth/wp-content/uploads/2020/02/Producer-Ownership-Project-LAUNCH-White-Paper.pdf>
- Dwork, C., Rothblum, G. N. & Vadhan, S. (2010). Boosting and differential privacy. IEEE 51st Annual Symposium on Foundations of Computer Science. IEEE.
- ECERA European Circular Economy Research Alliance. (2020). Digital circular economy - as a cornerstone of a sustainable European industry transformation. White Paper. Retrieved from https://www.era-min.eu/sites/default/files/publications/201023_ecera_white_paper_on_di
- ECHA, E. C. (2020, 10). ECHA-20-H-16-EN. Requirements for SCIP notifications. Helsinki, Finland. doi: 10.2823/686692
- Eilu, P., Bjerkgård, T., Franzson, H., Gautneb, H., Häkkinen, T., Jonsson, E., Keiding, J., Pokki, J., Raaness, A., Reginiussen, H., Róbertsdóttir, B., Rosa, D., Sadeghi, M., Sandstad, J., Stendal, H., Þórhallsson, E. & Törmänen, T. (2021). The Nordic supply potential of critical metals and minerals for Green Energy Transition. Nordic Innovation Report. Retrieved from <https://norden.diva-portal.org/smash/get/diva2:1593571/FULLTEXT02>
- Ellen MacArthur Foundation. (2016). Intelligent Assets: Unlocking the Circular Economy Potential. Appendix: Selected Case Studies.

- EURACTIV. (2021). EU leaders to call for progress in common data spaces, summit drafts reveal. Retrieved from <https://www.euractiv.com/section/digital/news/eu-leaders-to-call-for-progress-in-common-data-spaces-summit-drafts-reveal/>
- European Commission. (2013, May 4). Commission Recommendation on the use of common methods to measure and communicate the life cycle environmental performance of products and organisations. Commission Recommendation 2013/179/EU. Retrieved from <http://data.europa.eu/eli/reco/2013/179/oj>
- European Commission. (2014). Ecodesign your future.
- European Commission. (2018). A European Strategy for Plastics in a Circular Economy. Brussels, 16.1.2018. Retrieved from <https://eur-lex.europa.eu/legal-content/EN/TXT/?uri=COM:2018:28:FIN>
- European Commission. (2020a). Digital Economy and Society Index (DESI) 2020. Thematic Chapters. European Commission. Retrieved from <https://digital-strategy.ec.europa.eu/en/policies/desi>
- European Commission. (2020b). Analytical Report 15. High-value datasets: understanding the perspective of data providers. Capgemini Invent, the European Data Portal. Luxembourg: Publications Office of the European Union. doi:10.2830/363773
- European Commission. (2020c). Shaping Europe's Digital Future. Luxembourg: Publications Office of the European Union. doi:10.2759/091014 KK-03-20-102-EN-N
- European Commission. (2020d). Datanhallintasäädös. Retrieved from <https://eur-lex.europa.eu/legal-content/FI/TXT/PDF/?uri=CELEX:52020PC0767&from=EN>
- European Commission. (2020e). European Commission Directorate General for Research and Innovation Healthy Planet. Categorisation System for the Circular Economy A sector-agnostic approach for activities contributing to the circular economy. 3/2020. Retrieved from https://circulareconomy.europa.eu/platform/sites/default/files/categorisation_system_for_the_ce.pdf
- European Commission. (2020f). European Blockchain Services Infrastructure (EBSI) - Open Market Consultation Report. Retrieved from https://ec.europa.eu/newsroom/dae/document.cfm?doc_id=69281.

- European Commission. (2021a, 10 13). Integrated Administration and Control System (IACS). Retrieved from https://ec.europa.eu/info/food-farming-fisheries/key-policies/common-agricultural-policy/financing-cap/financial-assurance/managing-payments_en
- European Commission. (2021b). Initiative on substantiating green claims. Retrieved from https://ec.europa.eu/environment/eusssd/smgp/initiative_on_green_claims.htm
- European Commission. (2021c). Level(s). Retrieved from https://ec.europa.eu/environment/topics/circular-economy/levels_en
- European Environment Agency. (2020). Paving the way for a circular economy: insights on status and potentials. EEA Report no. 11/2020. Retrieved from <https://www.eea.europa.eu/publications/circular-economy-in-europe-insights>
- European Parliament. (2021). Legislative train schedule. European Green Deal. Strategy for a sustainable built environment. Retrieved from <https://www.europarl.europa.eu/legislative-train/theme-a-european-green-deal/file-strategy-for-a-sustainable-built-environment>.
- European Policy Centre. (2020). The digital circular economy: A driver for the European Green Deal. Main findings of the EPC Task Force "A digital roadmap for a circular economy".
- European Union. (2021). 2030 Digital Compass: the European way for the Digital Decade. Retrieved October 8, 2021, from European Commission Web site: <https://digital-strategy.ec.europa.eu/en/policies/europes-digital-decade>
- Eurostat. (2021a). Circular economy indicators. Retrieved from <https://ec.europa.eu/eurostat/web/circular-economy/indicators>
- Eurostat. (2021b). EU resource productivity slightly decreased in 2020. Retrieved October 8, 2021, from Eurostat: <https://ec.europa.eu/eurostat/web/products-eurostat-news/-/ddn-20210713-1>
- Evira. (2013). Nautarekisterin esiselvitys. Retrieved 15.2.2022, from source: <https://www.ruokavirasto.fi/globalassets/viljelijat/elaintenpito/elainten-merkinta-ja-rekisterointi/nauta/uusi-nauta/nautarekisterin-esiselvitysraportti-ii.pdf>. (Finnish food authority 2022, site visited 15.2.2022) <https://www.ruokavirasto.fi/viljelijat/elaintenpito/elainten-merkinta-ja-rekisterointi/nautaelaimet/uusi-nautarekisteri-hanke/>

- Farbes, J., Haley, B. & Jones, R. (2020). Marginal Abatement Cost Curves for U.S. Net-Zero Energy Systems - A Systems Approach. Evolved Energy Research LLC and Environmental Defense Fund.
- Finfood, F.F. (2021, 12 14). [www.ruokatieto.fi](https://www.ruokatieto.fi/sites/default/files/media/flash/tietohaarukka_2021_englanti_forkful_of_facts.pdf). Retrieved from https://www.ruokatieto.fi/sites/default/files/media/flash/tietohaarukka_2021_englanti_forkful_of_facts.pdf
- Finnish Environment Institute SYKE. (2020). Elinympäristön tietopalvelu Liiteri. Retrieved from https://www.ymparisto.fi/fi/Elinympariston_tietopalvelu_Liiteri
- Finnish Environment Institute SYKE. (2021). Valtakunnallisen jätesuunnitelman seuranta. Retrieved from https://www.ymparisto.fi/fi/kulutus_ja_tuotanto/jatteen_ja_jatehuolto/jatesuunnittelu/valtakunnallinen_jatesuunnitelman_seuranta
- Finnish Food Authority. (2020, 8 24). Peltolohkoaineisto. Retrieved from Field register: <https://www.ruokavirasto.fi/tietoa-meista/avointieto/tiedonluovutukset/peltolohkoaineisto/>
- Finnish Food Authority. (2021, 10 13). Viljelijätukien hakuopas 2021, Liite B. Retrieved from <https://www.ruokavirasto.fi/globalassets/viljelijat/opaat/hakuoppaat/hakuoppaan-liitteet/viljelijatukien-hakuopas-liite-b.xlsx>
- Finnish Government. (2019). Programme of Prime Minister Sanna Marin's Government 10 December 2019. Inclusive and competent Finland - a socially, economically and ecologically sustainable society. Helsinki: Finnish Government. Retrieved from <http://urn.fi/URN:ISBN:978-952-287-811-3>
- Finnveden, G. H. (2009). Review: Recent developments in Life Cycle Assessment. *Journal of Environmental Management* 91 (1), 1–21.
- Gaia-X. (2021). Gaia-X European Association for Data and Cloud AISBL. Retrieved October 10, 2021, from <https://www.gaia-x.eu/who-we-are/association>
- GBA. (2020). The Global Battery Alliance Battery Passport. Giving an identity to the EV's most important component. Retrieved from <https://www.globalbattery.org/publications/>
- Geissdoerfer, M., Morioka, S. N., de Carvalho, M. M. & Evans, S. (2018). Business models and supply chains for the circular economy. *Journal of Cleaner Production* (190), 712–721. doi:<https://doi.org/10.1016/j.jclepro.2018.04.159>

- Ghisellini, P., Cialani, C. & Ulgiati, S. (2016). A review on circular economy: The expected transition to a balanced interplay of environmental and economic systems. *Journal of Cleaner Production* (114), 11–32. doi:<https://doi.org/10.1016/j.jclepro.2015.09.007>
- Goodfellow, I., Bengio, Y. & Courville, A. (2016). *Deep learning*. Vol. 1. No. 2. Cambridge: MIT press.
- Grönroos, J., Munther, J. & Luostarinen, S. (2017). Calculation of atmospheric nitrogen and NMVOC emissions from Finnish agriculture - Description of the revised model. Finnish Environment Institute. Retrieved from <http://hdl.handle.net/10138/229364>
- Hakala, K., Kontturi, M. & Pahkala, K. (2009). Field biomass as global energy source. *Agricultural and food science*, 347–365.
- Hartikainen, H., Riipi, I., Katajajuuri, J. & Silvennoinen, K. (2020). From Measurement to Management: Food Waste in the Finnish Food Chain. In E. Närvänen, N. Mesiranta, M. Mattila & A. Heikkinen, *Food Waste Management*. Palgrave Macmillan, Cham. doi:https://doi.org/10.1007/978-3-030-20561-4_16
- Heckerman, D. (2008). A tutorial on learning with Bayesian networks. *Innovations in Bayesian networks*, 33–82.
- Hedberg, A. & Šipka, S. (2020). The circular economy: Going digital. Retrieved from https://wms.flexious.be/editor/plugins/imagemanager/content/2140/PDF/2020/DRCE_web.pdf
- Hedberg, A., Šipka, S. & Bjerkem, J. (2019). Creating a digital roadmap for a circular economy. Retrieved from https://wms.flexious.be/editor/plugins/imagemanager/content/2140/PDF/2019/pub_difital_roadmap_for_circular_economy.pdf.
- Helsingin Sanomat. (2021, October 11). Liike hyytyy. Retrieved from Helsingin Sanomat: <https://www.hs.fi/visio/art-2000008002897.html>
- Hildén, M., Berg, A., Salo, H., Alhola, K., Horn, S., Jokinen, A., Jokinen, P., Junnila, S., Karppinen, T., Kivikytö-Reponen, P., Korhonen-Kurki, K., Lammi, M., Lehtimäki, H., Leino, H., Lintunen, J., Myllymaa, T., Ottelin, J. & Ritschkoff, A.-C. (2021). Kiertotalouden strategisen ohjelman arvio SYKE 7/2021. Helsinki: Suomen Ympäristökeskus. Retrieved from <https://helda.helsinki.fi/handle/10138/326688>

- Hokka, J. & Eilu, P. (2021). Report on harmonization issues, data gaps and challenges, also reviewing the quality of Pan-European aggregated inventories for selected commodities. Mintell4EU Deliverable 4.2.
- Honkajoki. (2020). Vastuullisuusraportti 2020. Retrieved 15.2.2022, from source: https://www.honkajokioy.fi/wp-content/uploads/2021/06/Honkajoki_vastuullisuusraportti2020_FIN_2020.pdf
- HSL. (2019). MAL 2019: Helsinki Regions land use, housing and transport. Retrieved from https://www.hsl.fi/sites/default/files/uploads/mal2019_suunnitelmaraportti_27052019.pdf
- Hurskainen, P., Salminen, J., Balázs, A., Johansson, A., Kangas, A., Karppinen, T. K. M., Laturi, J., Mäyrä, J., Pohjola, J., Savolainen, H., Tuominen, S., Vihervaara, P. & Virkkunen, H. (2021). Novel methods for the accounting of forest ecosystems and circular materials. Retrieved from https://www.syke.fi/en-US/Research_Development/Research_and_development_projects/Projects/Novel_methods_for_the_accounting_of_forest_ecosystems_and_circular_materials_ENVECO
- IDS. (2019). International Data Spaces (IDS). IDS – A standard for data sovereignty and an indispensable element of data ecosystems. November 2019. Retrieved from <https://internationaldataspaces.org/wp-content/uploads/IDSA-Brochure-IDS-Standard-for-Data-Sovereignty-Indispensable-Element-for-Data-Ecosystems.pdf>
- IEC 60300-3-3:2017. (2017). Dependability management – Part 3-3: Application guide – Life cycle costing. Geneva, Switzerland.
- International Data Spaces Association. (2021). GAIA-X and IDS. Position Paper / Version 1.0 / January 2021. Retrieved from <https://internationaldataspaces.org/wp-content/uploads/IDSA-Position-Paper-GAIA-X-and-IDS.pdf>
- International Organization for Standardization. (2013). Consumer product safety — Guidelines for suppliers. ISO 10377:2013.
- International Organization for Standardization and International Electrotechnical Commission. (2014). Safety aspects — Guidelines for their inclusion in standards. ISO/IEC Guide 51.

- Iofrida, N., Strano, A., Gulisano, G. & Luca, A. (2018). Why social life cycle assessment is struggling in development? *Int J Life Cycle Assess* (23), 201–203. doi:<https://doi.org/10.1007/s11367-017-1381-0>
- IPCC. (2019). Food Security. In: *Climate Change and Land: an IPCC special report on climate change, desertification, land degradation, sustainable land management, food security, and greenhouse gas fluxes in terrestrial ecosystems*. IPCC, WMO, UNEP.
- Jafaryeganeh, H., Ventura, M. & Guedes Soares, C. (2020). Effect of normalization techniques in multi-criteria decision making methods for the design of ship internal layout from a Pareto optimal set. *Struct Multidisc Optim* (62), 1849–1863. doi:[doi: 10.1007/s00158-020-02581-9](https://doi.org/10.1007/s00158-020-02581-9).
- Kanawaday, A. & Sane, A. (2017). Machine learning for predictive maintenance of industrial machines using IoT sensor data. *8th IEEE International Conference on Software Engineering and Service Science (ICSESS)*.
- Kautto, P., Kalimo, H., Salo, H., Heinonen, T., Lifset, R., Mateo, E., Nissinen, A., Leskinen, P., Miettinen, M., Turunen, T. & Jukka, A. (2021). The Circular Economy and product policy. Publications of the Government’s analysis, assessment and research activities 2021:47. Retrieved from <http://urn.fi/URN:ISBN:978-952-383-283-1>
- Khayyam, H., Naebe, M., Milani, A. S., Fakhrhoseini, S. M., Date, A., Shabani, B., Atkiss, S., Ramakrishna, S., Fox, B. & Jazar, R. N. (2021). Improving energy efficiency of carbon fiber manufacturing through waste heat recovery: A circular economy approach with machine learning. *Energy* (225), 120113.
- Kirchherr, J., Piscicelli, L., Bour, R., Kostense-Smit, E., Muller, J., Huibrechtse-Truijens, A. & Hekkert, M. (2018). Barriers to the Circular Economy: Evidence from the European Union (EU). *Ecol. Econ.* (150), 264–272. doi:[doi: 10.1016/j.ecolecon.2018.04.028](https://doi.org/10.1016/j.ecolecon.2018.04.028).
- Kirchherr, J., Reike, D. & Hekkert, M. (2017). Conceptualizing the circular economy: An analysis of 114 definitions, *Resources, Conservation and Recycling*. (Vol. 127).
- Klöpffer, W. (2003). Life-cycle based methods for sustainable product development. *International Journal of Life Cycle Assessment*, 8(3), 157–159.
- Konietzko, J., Bocken, N. & Hultink, J. E. (2020). A Tool to Analyze, Ideate and Develop Circular Innovation Ecosystems. *Sustainability*, 12(1), 417.
- Koskinen, J. (2021, 3 22). Interview on monitoring of reuse.

- Kouhizadeh, M., Zhu, Q. & Sarkis, J. (2019). Blockchain and the circular economy: potential tensions and critical reflections from practice. *Prod. Plan. Control Manag. Oper.*, 31(11-12), 950–966. doi: doi: 10.1080/09537287.2019.169592
- Kristoffersen, E., Blomsma, F., Mikalef, P. & Li, J. (2020). The smart circular economy: A digital-enabled circular strategies framework for manufacturing companies. *Journal of Business Research*, 0148–2963. doi:<https://doi.org/10.1016/j.jbusres.2020.07.044>
- Kristoffersen, E., Li, Z., Li, J., Jensen, T. H., Pigosso, D. C. & McAloone, T. C. (2020). Smart Circular Economy: CIRCit Workbook 4. Smart Circular Economy: CIRCit Workbook 4 — Welcome to DTU Research Database.
- Kumar, A., Sah, B., Singh, A., Deng, Y., He, X., Kumar, P., & Bansal, C. (2017). A review of multi criteria decision making (MCDM) towards sustainable renewable energy development. *Renewable and Sustainable Energy Reviews*(69). doi:Doi: 10.1016/j.rser.2016.11.191.
- Lehtonen, E., Anttila, P., Hakala, K., Kolehmainen, M., Lehtinen, H., Lehtoranta, S., Luostarinen, S., Maharjan, A., Merilehto, K., Mäntylä, V. & Niemeläinen, O. (in preparation). An open web-based GIS service for biomass data. Manuscript in preparation.
- Lehtonen, E., Lindroos, M., Anttila, P., Kotiharju, A., Luostarinen, S., Niemeläinen, O., Hakala, K., Merilehto, K., Kolehmainen, M., Lehtinen, H. & Haavisto, T. (2017). Biomassa-atlas. (Natural Resources Institute Finland (Luke)) Retrieved 12 23, 2021, from <https://projects.luke.fi/biomassa-atlas/>
- Lemos, P. (2020). Hamburg Sustainability Session #2: Towards a Circular Economy. Presentation on Product Passport. In P. L. B1. (Ed.). Retrieved from <https://essr.eu/wp-content/uploads/Keynote-1-Paulo-da-Silva-Product-passport.pdf>
- Lihatiedotusyhdistys ry. (2018, 8 17). Lihatiedotus. Retrieved from Rehut ja vesi: <https://www.lihatiedotus.fi/tilalta-kauppaan/alkutuotanto/elainten-olotiloilla/rehut-ja-vesi.html>
- Linkov, I., Satterstrom, F., Kiker, G., Batchelor, C., Bridges, T. & Ferguson, E. (2006). From comparative risk assessment to multi-criteria decision analysis and adaptive management: recent developments and applications. *Environ. Int.*, 32(8), 1072–93. doi:doi: 10.1016/j.envint.2006.06.013
- Lopes de Sousa Jabbour, A. B., Rojas Luiz, J. V., Rojas Luiz, O., Jabbour, C. J., Ndubisi, N. O., Caldeira de Oliveira, J. H. & Junior, F. H. (2019). Circular

- economy business models and operations management. *Journal of Cleaner Production* (235), 1525–1539. doi:<https://doi.org/10.1016/j.jclepro.2019.06.349>
- Luoma, P., Toppinen, A. & Penttinen, E. (2021). The Role and Value of Data in Realising Circular Business Models – a Systematic Literature Review. *Journal of business models*, 44–71.
- Luostarinen, S. & Kaasinen, S. (2016). Manure nutrient content in the Baltic Sea countries. Helsinki: Natural Resources Institute Finland (Luke).
- Luostarinen, S., Grönroos, J., Hellstedt, M., Nousiainen, J. & Munther, J. (2017a). Finnish Normative Manure System: System documentation and first results. National Resource Institute Finland. Retrieved from <http://urn.fi/URN:ISBN:978-952-326-443-4>
- Luostarinen, S., Grönroos, J., Hellstedt, M., Nousiainen, J. & Munther, J. (2017b). SUOMEN NORMILANTA – laskentajärjestelmän kuvaus ja ensimmäiset tulokset. Natural Resources Institute Finland. Retrieved from <http://urn.fi/URN:ISBN:978-952-326-441-0>
- Luostarinen, S., Perttilä, S., Nousiainen, J., Hellstedt, M., Joki-Tokola, E. & Grönroos, J. (2017c). Turkeläinten lannan määrä ja ominaisuudet: Tilaseurannan ja lantalaskennan tulokset. Retrieved from <http://urn.fi/URN:ISBN:978-952-326-439-7>
- LVM. (2021). State of Data Spaces. Study report. LVM Ministry of Transport and Communications. Retrieved from https://api.hankeikkuna.fi/asiakirjat/b0cf8878-816f-4913-a917-ee9c0884f60d/e416beab-7752-49f3-a964-8226719de182/LIITE_20211108141220.PDF
- Magazzino, C., Mele, M., Schneider, N. & Sarkodie, S. A. (2021). Waste generation, wealth and GHG emissions from the waste sector: Is Denmark on the path towards circular economy? *Science of the Total Environment* (755), 142510.
- Malahat, G. & Happonen, A. (2020). New Promises AI brings into circular economy accelerated product design: a review on supporting literature. *E3S Web Conf.*, 10.
- Materiaalitori. (2021). Tietoa palvelusta. Retrieved July 6, 2021, from <https://www.materiaalitori.fi/tietoa-palvelusta>
- McKinsey. (2009). Pathways to a Low-Carbon Economy, Version 2 of the Global Greenhouse Gas Abatement Cost Curve.

- Merilehto, K. & Salmenperä, H. (2021). Jätedirektiivi (1004/2019/EY), kierrätysasteiden saavuttaminen vuonna 2019. Retrieved from <https://ckan.ymparisto.fi/envi-reports/jatedirektiivi-1004-2019>
- Ministry of Economic Affairs and Employment of Finland. (2021). Sector report on the mining industry. Innovations and Enterprise Financing. Helsinki: Ministry of Economic Affairs and Employment of Finland. Retrieved 8 15, 2021, from <https://julkaisut.valtioneuvosto.fi/handle/10024/163279>
- Ministry of the Environment. (2021a). Ympäristönsuojelun valvonnan sähköinen asiointijärjestelmä YLVA. Retrieved from <https://www.ymparisto.fi/YLVA>
- Ministry of the Environment. (2021b). GOVERNMENT RESOLUTION ON THE STRATEGIC PROGRAMME FOR CIRCULAR ECONOMY. Ministry of the Environment Resolution 8 April 2021.
- Ministry of the Environment. (2021c). Rakennetun ympäristön tietojärjestelmä. Retrieved from <https://ym.fi/ryhti>
- Ministry of the Environment. (2021d). Vähähiilisen rakentamisen tiekartta. Retrieved from <https://ym.fi/vahahiilisen-rakentamisen-tiekartta>
- Morningstar. (2021). 2020 oli ennätysvuosi vastuullisille rahastoille. Retrieved from <https://www.morningstar.fi/fi/news/211158/2020-oli-enn%C3%A4tyvuosi-vastuullisille-rahastoille.aspx>
- Motiva Oy. (2020). Huoneistokohtaista vedenmittausta ja laskutusta koskeva lakiuudistus. Retrieved from https://www.motiva.fi/koti_ja_asuminen/taloyhtiot_-_yhdessä_energiatohokkaasti/vesi_ja_vedenkulutus/vedenkulutusmittauksen_lakiuudistus
- Motiva Oy. (2021). Materiaalitori. Retrieved from <https://www.materiaalitori.fi/tietoa-palvelusta>
- Nagel, L. & Lycklama, D. (2021). Design Principles for Data Spaces. Position Paper. Version 1.0. Berlin. doi: <http://doi.org/10.5281/zenodo.5105744>
- NAP. (2021). Finnish national open transport service catalog. Retrieved from <https://www.finap.fi/#/>
- National Land Survey Finland. (2021, 12 23). Paikkatietohakemisto. Retrieved 12 23, 2021, from Paikkatietohakemisto: <https://www.paikkatietohakemisto.fi/geonetwork/srv/fin/catalog.search#/metadata/bc83cca7-0dde-4b69-9659-699843a488bd>

- National Land Survey of Finland. (2021). Paikkatietoikkuna (National geoportal service). Retrieved from <https://kartta.paikkatietoikkuna.fi/?lang=en>
- Natural Resources Institute Finland (Luke). (2021). Biomass Atlas. Retrieved 12 23, 2021, from Biomass Atlas Map: <https://biomassa-atlas.luke.fi/>
- Natural Resources Institute Finland. (2021). Official Statistics of Finland, Crop production statistics.
- Nguyên, T. T. (2016). Collecting and analyzing data from smart device users with local differential privacy. Retrieved from arXiv:1606.05053
- Norris, G. (2015). Handprint-Based NetPositive Assessment. Boston: Harvard T.H. Chan School of Public Health.
- Official Statistics of Finland. (2010, 12 22). Crop Production Statistics. Retrieved from <https://stat.luke.fi/en/tilasto/175/kuvaus/1128>
- Official Statistics of Finland. (2018). Waste statistics [e-publication]. Helsinki: Statistics Finland. Retrieved August 19, 2021
- OPENDEI. (2020). https://twitter.com/opendei_eu/status/1270283734705672192.
- Orasmaa, A., Laurila, L., & Liimatainen, H. (2020). Rethinking ownership. Producer ownership models in a circular economy. *Sitra studies*, 176. Retrieved from <https://media.sitra.fi/2020/12/02164106/rethinking-ownership.pdf>
- Pagoropoulos, A., Pigosso, D. C. & McAlloone, T. C. (2017). The emergent role of digital technologies in the Circular Economy: A review. *Procedia CIRP* (64), 19–24.
- Pajunen, J. (2019). Alustava selvitys biokaasulaitoksen kannattavuudesta UPM Tervasaaren paperitehtaalla. Tampere: Tampere University of Applied Sciences.
- Personal Data Act 523/1999. (2021, 10 13). Retrieved from <https://www.finlex.fi/fi/laki/kaannokset/1999/en19990523.pdf>
- Pirkanmaa Centre for Economic Development, Transport and the Environment. (2019). Tuottajavastuun tilastot. Retrieved from https://www.ymparisto.fi/fi-FI/Kartat_ja_tilastot/Jatetilastot/Tuottajavastuun_tilastot
- Poore, J. & Nemecek, T. (2018). Reducing food's environmental impacts through producers and consumers. *Science*, 987–992.

- Puustinen, H. (2020). Säilörehuhävikkien selvittäminen haastavaa - mutta palkitsevaa: Case-tutkimukset pohjoissavolaisilla maataloilla. Savonia university of applied sciences. Noudettu osoitteesta <https://urn.fi/URN:NBN:fi:amk-2020052112794>
- Qdais, H. A., Hani, K. B. & Shatnawi, N. (2010). Modeling and optimization of biogas production from a waste digester using artificial neural network and genetic algorithm. *Resources, Conservation and Recycling*, 54(6), 359–363.
- Rajala, R., Hakanen, E., Mattila, J., Seppälä, T. & Westerlund, M. (2018). How Do Intelligent Goods Shape Closed-Loop Systems? *California Management Review* (60), 20–44. doi:<https://doi.org/10.1177/0008125618759685>
- Rasilainen, K., Eilu, P., Ahtola, T., Halkoaho, T., Kärkkäinen, N., Kuusela, J., Lintinen, P. & Törmänen, T. (2018). Quantitative assessment of undiscovered resources in lithium–caesium–tantalum pegmatite-hosted deposits in Finland. *Geol. Surv. Finland, Bull.*
- Rasilainen, K., Eilu, P., Halkoaho, T., Heino, T., Huovinen, I., Iljina, M., Juopperi, H., Karinen, T., Kärkkäinen, N., Karvinen, A., Kontinen, A., Kontoniemi, O., Kousa, J., Lauri, L., Lepistö, K., Luukas, J., Makkonen, H., Manninen, T. & Niiranen, T. (2017). Assessment of undiscovered metal resources in Finland. *Ore Geology Reviews* (86), 896–923.
- Rasilainen, K., Eilu, P., Huovinen, I., Konnunaho, J., Niiranen, T., Ojala, J. & Törmänen, T. (2020). Quantitative assessment of undiscovered resources in Kuusamo-type Co-Au deposits in Finland. *Geological Survey of Finland Bulletin*.
- Regulation (EU) 2019/881. (2019, April 17). Regulation (EU) 2019/881 of the European Parliament and of the Council on ENISA (the European Union Agency for Cybersecurity) and on information and communications technology cybersecurity certification and repealing Regulation (EU) No 526/2013. Retrieved from https://eur-lex.europa.eu/legal-content/EN/TXT/?uri=uriserv:OJ.L_.2019.151.01.0015.01.ENG
- Riipi, I., Hartikainen, H., Silvennoinen, K., Joensuu, K., Vahvaselkä, M., Kuisma, M. & Katajajuuri, J.-M. (2021). Elintarvikejätteen ja ruokahävikin seurantajärjestelmän rakentaminen ja ruokahävikkitiekartta. *Elintarvikejätteen ja Luonnonvara- ja biotalouden tutkimus* (49). Retrieved from <https://jukuri.luke.fi/handle/10024/547657>
- Rivas, A., Fraile, J., Chamoso, P., González-Briones, A., Sittón, I. & Corchado, J. (2019). A predictive maintenance model using recurrent neural networks. *International Workshop on Soft Computing Models in Industrial and Environmental Applications*. Springer, Cham.

- Rowe, G. & Wright, G. (1999). The Delphi technique as a forecasting tool: issues and analysis. *International Journal of Forecasting*, 15, 353–375.
- Ruokamo, E., Savolainen, H., Seppälä, J., Sironen, S., Räisänen, M., Auvinen, A.-P. & Antikainen, R. (2021). *Kiertotalous vähähiilisyiden edistäjänä ja luonnon monimuotoisuuden turvaajana*. Helsinki: Ympäristöministeriö. Retrieved from <http://urn.fi/URN:ISBN:978-952-361-205-1>
- Rupert Resources. (2021). Media release 13 September 2021. Retrieved from <https://rupertresources.com/maiden-inferred-resource-for-ikkari-of-49-million-tonnes-grading-2-5-grams-per-tonne-3-95-million-ounces-of-gold/>
- Sabaei, D., Erkoyuncu, J. & Roy, R. (2015). A Review of Multi-criteria Decision Making Methods for Enhanced Maintenance Delivery. *Procedia CIRP* (37), 30–35. doi:doi: 10.1016/j.procir.2015.08.086.
- Salminen, J., Tikkanen, S. & Koskiahio, J. (2017). Kohti vesiviisasta kiertotaloutta, SYKE 16/2017. SYKE.
- Salo, H., Suikkanen, J. & Nissinen, A. (2019a). Nordic Swan Ecolabel and Organisation Environmental Footprint. Focus on the organisation environmental information used in the retail sector. *TemaNord*, 543. doi:). <http://dx.doi.org/10.6027/TN2019-543>
- Salo, H., Suikkanen, J. & Nissinen, A. (2019b). Use of ecodesign tools and expectations for Product Environmental Footprint. Case study of Nordic textile and IT companies. *TemaNord*, 542. doi:<http://dx.doi.org/10.6027/TN2019-542>
- SHAPING. (2020). European Commission, “Shaping Europe’s digital future – Questions and Answers,” Retrieved from https://ec.europa.eu/commission/presscorner/detail/en/qanda_20_264.
- Sitra. (2016). *Kierrolla kärkeen: Suomen tiekartta kiertotalouteen 2016-2025*. Retrieved from <https://media.sitra.fi/2017/02/27175308/Selvityksia117-3.pdf>
- Sitra. (2021a). The EU’s Sustainable product policy framework and producer ownership models are key to mainstreaming circular business models. EU Policy Brief 16.6.2021. Retrieved from <https://www.sitra.fi/en/articles/the-eus-sustainable-product-policy-framework-and-producer-ownership-models-are-key-to-mainstreaming-circular-business-models/>
- Sitra. (2021b). Data boosts the recirculation of materials in the circular economy marketplace. Examples. Retrieved from

<https://www.sitra.fi/en/cases/data-boosts-the-recirculation-of-materials-in-the-circular-economy-marketplace/>

Statistics Finland. (2021a). Indicators for the circular economy business. Retrieved from https://www.stat.fi/tup/kiertotalous/kiertotalousliiketoiminnan-indikaattorit_en.html

Statistics Finland. (2021b). Statistics Finland's free-of-charge statistical database. Retrieved from <https://pxnet2.stat.fi/PXWeb/pxweb/en/StatFin/>

Suomen Autokierrätys. (2021). Kierrätyslainsäädäntö. Retrieved from <https://www.autokierratys.fi/kuluttajille/kierratysjarjestelma/kierratyslainsaadanto/>

Suomen Kiertovoima ry KIVO. (2021). Koostumustietopankki. Retrieved from <https://kivo.fi/yymmarramme/koostumustietopankki/>

Swarr, T., Hunkeler, D., Klöpffer, W., Pesonen, H.-L., Ciroth, A., Brent, A. & Pagan, R. (2011). Environmental life-cycle costing: a code of practice. *The International Journal of Life cycle assessment* (16), 389–391.

TEG. (2020). Taxonomy: Final report of the Technical Expert Group on Sustainable Finance. EU Technical Expert Group on Sustainable Finance. Retrieved from https://ec.europa.eu/info/sites/info/files/business_economy_euro/banking_and_finance/documents/200309-sustainable-finance-teg-final-report-taxonomy_en.pdf

Tojo, N., Kogg, B., Kjørboe, N., Kjær, B. & Aalto, K. (2012). Prevention of textile waste - material flows of textiles in three Nordic countries and suggestions on policy instruments. *TemaNord*, 545.

Traficom. (2021). Mobility services interface information. (Page visited 2.7.2021). Retrieved from <https://www.traficom.fi/en/transport/liikennejarjestelma/mobility-services-interface-information>

Traficom/Deloitte. (2020). Selvitys ICT-alan nousevien teknologioiden vaikutuksista ympäristön- ja ilmastonmuutokseen. Traficom julkaisu 224/2020. Retrieved from https://www.traficom.fi/sites/default/files/media/publication/ICT_ilmastovaiikutukset_selvitys_Traficom_julkaisu_244_2020_17.8.20.pdf

Turvallisuus- ja kemikaalivirasto Tukes. (2021). Kemidigi - Kemikaalitieto yhdessä palvelussa. Retrieved from <https://www.kemidigi.fi>

- Turvallisuus- ja kemikaalivirasto Tukes. (2021). REACH - Rekisteröinti, luvat ja rajoitukset. Retrieved from <https://tukes.fi/kemikaalit/reach>.
- TWG. (2021a). Platform on sustainable finance: technical working group (2021). Taxonomy pack for feedback. Retrieved from https://ec.europa.eu/info/sites/default/files/business_economy_euro/banking_and_finance/documents/210803-sustainable-finance-platform-report-technical-screening-criteria-taxonomy_en.pdf
- TWG. (2021b). Platform on sustainable finance: technical working group (2021). PART B – Annex: Full list of Technical Screening Criteria. Retrieved from https://ec.europa.eu/info/sites/default/files/business_economy_euro/banking_and_finance/documents/210803-sustainable-finance-platform-report-technical-screening-criteria-taxonomy-annex_en.pdf
- TWG. (2021c). Platform on sustainable finance: technical working group (2021). Public Consultation Report on Taxonomy extension options linked to environmental objectives. Retrieved from https://ec.europa.eu/info/sites/default/files/business_economy_euro/banking_and_finance/documents/sustainable-finance-platform-report-taxonomy-extension-july2021_en.pdf
- UNECE. (2015). Bridging Document between the Committee for Mineral Reserves International Reporting Standards (CRIRSCO) Template and the United Nations Framework Classification for Resource (UNFC). UNECE Energy Series. Retrieved from www.unece.org/index.php?id34487
- UNECE. (2020). United Nations Framework Classification for Resources, Update 2019. UNECE Energy Series. Retrieved from https://www.unece.org/fileadmin/DAM/energy/se/pdfs/UNFC/publ/UNFC_ES61_Update_2019.pdf
- UNEP. (2009). Guidelines for social life cycle assessment of products. Paris, France.
- Valtioneuvosto. (2021). Uusi suunta – kiertotalouden strateginen edistämishjelma. Retrieved from <https://ym.fi/kiertotalousohjelma>
- Viskari, V., Koutonen, H., Retkin, R., Heikkala, E. & Korkiakoski, J. (2020). Alueellinen biomassakartoitus Circvol-hanke. Espoo: Ramboll.
- VYR, The Finnish Cereal Committee. (2020). Kansallinen viljastrategia 2012-2020. Retrieved from Vilja-alan yhteistyöryhmä: https://www.vyr.fi/document/1/124/dc2fa51/viljas_dfa7a15_32637_KansallinenViljastrategia_net.pdf

- Wang, D. & Yuming, Z. (2020). Implications for sustainability in supply chain management and the circular economy using machine learning model. *Information systems and e-Business Management*, 1–13.
- Wang, J.-B., Wang, J., Wu, Y., Wang, J.-Y., Zhu, H., Lin, M. & Wang, J. (2018). A machine learning framework for resource allocation assisted by cloud computing. *IEEE Network*, 32(2), 144–151.
- Wang, X. (2016). A Prediction Method of the Stability of the Recycling Industry Chain based on Bayesian Network. *International Journal of Simulation--Systems, Science & Technology* (7).
- Waste Act 646/2011. (2011). Waste Act 646/2011. Retrieved from <https://www.finlex.fi/fi/laki/ajantasa/2011/20110646>
- Watson, D., Trzepacz, S. & Gravggaard Pedersen, O. (2018). Mapping of textile flows in Denmark. The Danish Environmental Protection Agency, Environmental Project No. 2025.
- Whim. (2021). Whim Helsinki. Retrieved from <https://whimapp.com/helsinki/en/>
- World Economic Forum. (2019). Harnessing the Fourth Industrial Revolution for the Circular Economy Consumer Electronics and Plastics Packaging. Retrieved from http://www3.weforum.org/docs/WEF_Harnessing_4IR_Circular_Economy_report_2018.pdf
- Wu, S.-J., Gebraeel, N., Lawley, M. A. & Yih, Y. (2007). A neural network integrated decision support system for condition-based optimal predictive maintenance policy. *IEEE Transactions on Systems, Man, and Cybernetics-Part A: Systems and Humans*, 37(2), 226–236.

Appendix A. Sources of data for circular design in Finland

1. Food and carbon	3
1.1. Field and crop data.....	5
1.2. Crop-based products	14
1.3. Fertilizers.....	14
1.4. Feed	17
1.5. Feed waste and feed surplus	18
1.6. Livestock	18
1.7. Animal products.....	23
1.8. Manure	23
1.9. Slaughter waste and other side streams of animal origin	25
1.10. Food waste	26
1.11. Biowaste	29
1.12. Sewage sludge	29
1.13. Processing of manure and plant waste.....	29
1.14. Forest biomass, forest statistics.....	30
1.15. Food system data service – the Biomass Atlas	32
1.16. Calculation tool for regional nutrient and carbon recycling	33
2. Batteries – data through the battery value chain	34
2.1. Regional State Administrative Agency, water and environmental permits information service	34
2.2. Registration, Evaluation, Authorisation, and Restriction of Chemicals (REACH)	35
2.3. Hazardous chemicals data by Kemidigi.....	36
2.4. Substances in Products in the Nordic Countries (SPIN).....	37
2.5. Substances of Concern in Articles as such or in Complex Objects (SCIP) Database	38
2.6. Battery management system (BMS).....	40
2.7. Chemicals data by the Finnish Safety and Chemicals Agency (TUKES)	42
2.8. Producer responsibility register by the Pirkanmaa Centre for Economic Development, Transport and the Environment (PIRELY).....	43
2.9. International waste transfer data by the Finnish Environment Institute (SYKE)	44
3. Textiles	46
3.1. Textile flow survey 2021	46
3.2. Textile waste in municipal waste statistics	47
3.3. Monitoring of reused textile products under the EU Waste Framework Directive	49
3.4. Statistics by Suomen Tekstiili & Muoti (STJM)	50

3.5. Statistics and analyses by the European Apparel and Textile Confederation - Euratex	51
3.6. Telaketju Research Activities Research Data via the Telaketju webpage	52
3.7. Nordic cooperation in textiles	54
4. Primary mineral raw materials and mining waste	56
4.1. Mineral deposits and mines.....	56
4.2. Mining waste	61
4.3. Mineral statistics in the European Minerals Yearbook.....	65
4.4. Mineral exploration activity and results.....	71
4.5. Undiscovered mineral resources	75
4.6. Mineral exports and imports	80
5. Surveys on industrial production and material utilization	84
5.1. Industrial production materials and supplies	84
5.2. Industrial output.....	88
5.3. Environmental protection activities.....	94
6. Built environment.....	101
6.1. The built environment information system RYTJ.....	101
6.2. Emission database for building products, services, and systems, CO2data.fi	103
6.3. Construction and demolition waste.....	107
7. Plastics.....	109
7.1. Studies on secondary plastic flows in Finland	109
8. Other data sources for circular design approaches	112
8.1. Geographic data on the circular economy in the Liiteri database.....	112
8.2. Accounting of water use	113
8.3. Indicators for the development of circular business by Statistics Finland	114
9. Waste.....	116
9.1. National statistics on waste	116
9.2. Production and treatment of waste in the national environmental compliance monitoring system (YLVA).....	118
9.3. Producer responsibility statistics on waste	119
9.4. Monitoring of the National Waste Plan	122

1. Food and carbon

Eeva Lehtonen, Sari Luostarinen, Hannu Ilvesniemi

The global CO₂ balance in the atmosphere is dependent on the balance between carbon inputs and outputs to the atmosphere. The emissions from fossil fuels are the major driver in increasing atmospheric carbon, but biomass production and land use also have significant effects. Different EU countries have several national tools to estimate the biomass production of plant species commonly used in agriculture and forestry. This knowledge can be used when analysing the carbon cycles in agriculture and forestry. Global land use changes include afforestation, deforestation, reforestation, and urbanization.

Climate, land use, management, and edaphic factors affect the amount of carbon stocks, but changes in these pools are not well understood. Greenhouse gas emissions, carbon stocks, and stock changes are complex to measure, complicating the verification practices.

Net primary production and decomposition rates naturally vary between sites, but certain management practices are also known to have positive effects on the size of the different carbon stocks in forests and cultivated soils. In arable land, management practices and their history affect the accumulation of carbon. Globally applied conservation principles include minimizing soil disturbance, maximizing surface cover, and stimulating biological activity through cover crops, crop rotation, and integrated nutrient and pest management.

The Biomass Atlas gives detailed information on agricultural and forest products. Based on this annually accumulating information, it is possible to analyse the effects of the existing or planned new products or production methods on many aspects, such as carbon circulation, related to the circular economy. Awareness of the availability of detailed statistical data facilitates the development of new solutions.

The material budgets of the whole production chain of plant and animal-based products can be calculated using the mass and concentration of a selected biomass. When the circulation of food carbon is estimated, the whole production chain, including soil preparation, fertilization, irrigation, pest treatments, harvest, yield preparation, transport, industrial processing, transportation, food use, waste management, and the reuse of nutrients needs to be analysed.

At the moment, several types of methods to be used in carbon markets are under development. These products need to be able to quantify the sold carbon units, estimate the stability of the carbon added, and the economic and social acceptability of such operations. Good basic understanding of the processes and amounts related to carbon accumulation are essential parts of such markets.

The food chain spans from primary production through food manufacturing and processing to consumers. We cannot circulate food in a same way as we can circulate some other items, such as clothes or batteries. When talking about a circular economy, we emphasize material efficiency. All stages of the food chain are composed of different types of side streams. There is a need to develop these side

streams and minimize the losses, because significant amounts of carbon and nutrients are taken into the food chain, as well as emitted from it. Recycling or prolonging the circulation of carbon and nutrients would minimize the use of non-renewable inputs to the food chain and diminish waste.

In food chain, there are actors at many scales on farms and in manufacturing, retail and consumption. New actors have joined or should join to the chain to utilize different side stream biomasses and turn them into new products. In particular, recycled fertilizers are needed to enhance resource efficiency and self-sufficiency. Recycled fertilizers can contain organic matter or nutrients such as nitrogen and phosphorus. Organic matter maintains the fertility of soil and its ability to retain moisture, whereas nutrients are needed for plant growth.

Data related to carbon and nutrient cycles of the food chain is described based on a systemic description of the food chain (Figure A1).

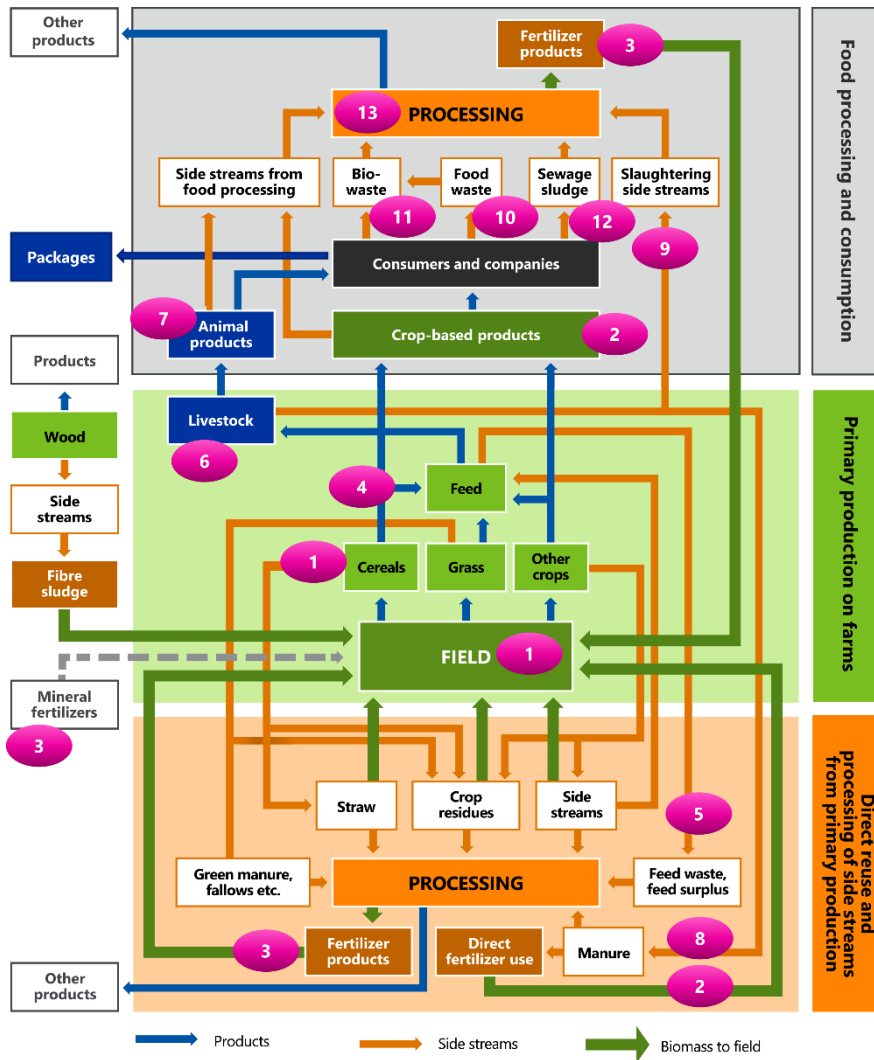

Figure A1. A systemic diagram of the food production chain. Numbers in pink ellipses relate to the data listed in Section 2.1, Table 1. The data are described in more detail in the following sections of the Appendix A, and the number also refers to the sections in Appendix A. For example, number 2 refers to Section 1.2 in Appendix A.

1.1. Field and crop data

There are several sources for field and crop data. The Finnish Food Authority maintains a register of fields and crops cultivated on them. The data is collected from the cultivation plans of each farm. Thus, it reflects the situation in agricultural

land use. Natural Resources Institute Finland (Luke) is one of the official statistics authorities in Finland and collects statistics on agriculture, crops, and crop yields. Crop statistics are collected after each harvest season; therefore, they describe crops harvested, harvested area, crop yield and the crop yield per hectare. Luke has a map service called the Biomass Atlas, which combines the register data from the Finnish Food Authority and Luke statistics in thematic maps and datasets and presents estimations of field use, crop potential, and side streams of cultivated crops.

Description of the IACS register

The Common Agricultural Policy of European Union has been applied in Finland since 1995. Approximately 90% of farmers have committed to the system and it covers more than 90% of the field area. The Integrated Administration and Control System (IACS) ([European Commission, 2021a](#)) database is maintained for management of the payment system.

The field register (part of the IACS) of the Finnish Food Authority has approximately 200 different plant or land use codes for different types of field use. For each field, there is the name and code for the plant cultivated, the cultivation area, field location, and shape of the field. Plant codes for 2021 can be found in the [application guide](#) for EU subsidies. Some examples are given in Table A1.

Although the data is collected for administration and control purposes, it can also be used to calculate biomass potentials, monitor land use, and estimate nutrient demand in different areas, among other uses.

Sources of IACS data

The Finnish Food Authority collects register on the cultivation plans of Finnish farmers (Finnish Food Authority, 2020). The original data owner is therefore the farmer. The integrated administration and control system, [IACS \(European Commission, 2021a\)](#), is a register for the management of payments to farmers, who every spring report the cultivation plans for the coming growing season.

IACS data set properties

The time span for field parcel data is from 1995 to the current year. New plant codes might appear when the terms for the Common Agricultural Policy (CAP) change. In addition, some old codes might be taken out of use. Usually, the continuity of the codes is good, and it is possible to form continuous time series of data.

IACS data access

The documents of the authorities are public, based on law (Act on the Openness of Government Activities 621/1999, 1999). In addition to the Act on openness, the

Personal Data Act (Personal Data Act 523/1999, 2021) applies to register data, because it is possible to join field data to farmer data, which is personal data. Therefore, it is possible to obtain the data for scientific research, and the researcher in charge must ensure that the personal data is not disclosed to outsiders.

For research purposes, it is possible to ask the Finnish Food Authority to detach certain data from their register. Permission for this is required first. Usually, it takes several weeks to ask and gain the permission, and then later obtain the data. A fee covers work expenses and is typically some hundreds of euros.

Just at the time of finalizing this report, the Finnish Food Authority published the WMS and WFS services for IACS data, which are defined by the INSPIRE standards. The WMS service is described in Paikkatietohakemisto (National Land Survey Finland, 2021).

Technologies

The data is collected from those farmers who have committed to implementing the Common Agricultural Policy and who obtain payments based on cultivation areas. In Finland, approximately 44 300 farmers participate in the Vipu service and only 2500 farmers send the information in paper format. Other EU member countries have the same system of subsidies and database for integrated administration. In Finland, data is collected every spring by [Vipu electronic services](#) from farmers.

The data is assigned from the database of the Food Authority in text format, e.g., *-dat format, and sent by e-mail or secure link for download.

Future developments of IACS data

The database is expected to be maintained in the future, as the Common Agricultural Policy, as well as subsidies for food production, will continue. Changes in attributes are expected along with policy changes.

Gaps and opportunities of IACS data

The IACS database was originally designed to collect data for the administration and control of subsidies for food production. Its use for circular economy applications is therefore restricted:

For cereals, potatoes, and vegetables, data is available on the species and even the cultivar level. On the other hand, grass species are not specified, but there are several different land use and subsidy types where grass is produced, with the intensity of production varying widely. More exact data on the plant species and cultivation intensity would be needed for accurate calculations of the nutrient demand of plants, which is needed when planning the application of manure and recycled fertilizers to soil.

As the primary purpose of data collection is the administration of the Common Agricultural Policy (CAP), the data attributes might change between CAP seasons.

New plant codes and especially land use codes appear and some old codes cease to be used.

Cropping plans by farmers change depending on the market prices and springtime weather conditions. Therefore, the actual situation in farming can be seen from the IACS register. For trends or the long-term situation, it is recommendable to examine the data over multiple years.

Description of crop production statistics

Crop production statistics contain harvest data on Finland's most important field crops, including cereals (wheat, rye, barley, and oats), turnip rape, potato, sugar beet, and herbage crops. A detailed description of the statistics can be found at <https://stat.luke.fi/en/tilasto/175/kuvaus/1128> (Official Statistics of Finland, 2010).

Sources of data

Natural Resources Institute Finland (Luke) produces and processes Finland's statistics on food and natural resources. Producing statistics about agricultural production is one of its basic tasks as a statistical author. Statistical data can be found on the Luke website <https://stat.luke.fi/en>

Agricultural statistics are produced to follow and understand agriculture and its development and trends. They are needed in decision making, for example, regarding food security, regional development, and environmental protection.

Data set properties

Data is available for the whole of Finland and separate Centres for Economic Development, Transport, and the Environment (ELY Centres). Data is available from the 1920s onwards. The statistics contain harvest data on Finland's most important field crops. The cereals included are spring and winter wheat, rye, malting barley, feed barley, oats, mixed grain, and other grains. Other plant groups are turnip rape, oilseed rape, caraway, peas, table potatoes, early potatoes, processed food potatoes, starch potatoes, other potatoes, and sugar beet. The herbage crops included are timothy seeds, hay, fresh grass, silage (fresh and dried), and reed canary grass. The statistics also contain harvest data for green chop, wholegrain silage, and fresh silage. Data on the field crop harvest is presented in both kilos per hectare (10,000 m²) and as the total yield in millions of kilos. The dry matter content of harvested herbage is also given.

The statistics are updated annually.

Data access

Crop statistics are public, open, and free to use. A reference to mention is OSF: Natural Resources Institute Finland, Crop production statistics.

Technologies

Field area data is mainly gathered from farmers during their dealings with Finland's agricultural industry administration. The per-hectare harvest data is based on information collected from farmers by statistical data inquiry.

Statistics are available at <https://stat.luke.fi/en/crop-production-statistics> with different options to explore, edit, and save the data as tables, figures, files, links, and html embeddings. Data can be downloaded as files or read through the PX-Web API (application programming interface) in the following formats: xlsx, csv, json, json stat, sdmx, and px.

There is also a web portal for statistical information. The figures on the statistics websites are an example of PX-Web API implementation. The data behind the figures are loaded every time the web page is opened or updated, and when the database is updated, the figures are updated automatically.

Future developments

Due to the long history and well-established regime of the statistics, the continuity of the data is also expected to be good in the future.

The reported crops can change depending on the extent of cultivation. For example, the triticale yield was requested this year, and oil hemp will be requested next year for the first time.

Legislation changes for Eurostat reports (SAIO regulation) will cause some changes to the content of statistics. Silages will be calculated as dry matter and the sugar beet yield will probably also be reported as sugar produced. (European Parliament, 2021)

A larger part of the agricultural area will be addressed for non-marketable products. There will be more statistics on various environmental subsidies, carbon sequestration, etc., in addition to traditional statistics on primary production.

The use of satellite data in arable crop statistics is changing data collection. Maps will be used for data publication. Initially, PxWeb data will be exported to map templates, and in the next step, it will be possible to combine the data in the national geodata portal, [Paikkatietoikkuna \(National Land Survey Finland P. , 2021\)](#), with the data of different data producers.

Gaps and opportunities

The objective and need for crop data collection developed long before there was any idea of a circular economy. Circularity has been built into old-fashioned agriculture, although it was not named as such or measured, and the need for monitoring has decreased as volumes have grown. Despite measuring production more than circularity, the statistical data is well structured and suits many purposes. Crop data can be used for circular economy planning; for example, plant and crop data is needed to plan the more effective use of nutrients in agriculture.

When making decisions regarding whether one should use the data of a certain year or long-term averages, it is good to keep in mind that there is variation between years. Weather conditions during the growing season and harvest time affect crop quality and decisions regarding whether a cereal crop will be harvested for feed, flour, or malt, or silage sward will be harvested for silage, hay, or green fodder.

In a circular economy, considerable emphasis is placed on the better utilisation of side streams. There is no statistical data on side streams in agriculture, they can be estimated with statistical data and literature values, which has been done in the Biomass Atlas.

Description of field, crop, and side stream data in the Biomass Atlas

The Biomass Atlas (1.15) combines the field data from the IACS register and Luke crop production statistics, presenting data on land use, crop potential, and crop side streams.

Crop data from the IACS register have been sorted and reclassified for the Biomass Atlas according to the land use, crop yield, and side stream type. In Table A1, some examples of IACS plant codes and reclassification in the Biomass Atlas land use classes are given.

Table A1. Some examples of plant codes in the IACS register and the Biomass Atlas.

Plant name	Plant code	Biomass Atlas class
Winter wheat	1110	Winter wheat
Spring wheat	1120	Spring wheat
Durum wheat	1130	Not classified
Winter spelt wheat	1141	Winter wheat
Spring spelt wheat	1142	Spring wheat
Winter triticale	1210	Triticale
Spring triticale	1211	Triticale
...		
Food potato	3110	Potato
Food industry potato	3120	Potato
Starch potato	3130	Potato
...		
Green manures	6050	Green manure sward
1-year grassland for hay, silage, and green fodder	6111	Silage
1-year grassland for pasture	6112	Cultivated pasture
...		
Cultivation for honey production	9060	Special crops
Green fallow	9412	

Plant name	Plant code	Biomass Atlas class
Nature management fields	9405	Green fallow and nature management fields
Fields for diversity	9422	Fields for diversity and landscape
Buffer zone	9820	Buffer zones and strips

Sources of biomass data

The Biomass Atlas is a service that gathers spatial data on biomasses formed in forestry, agriculture, the food industry, and municipalities (Lehtonen, et al., in preparation). Consisting of approximately 300 data layers and covering all of Finland, the Biomass Atlas is a significant source of data on land use, production, side streams, and wastes. It has been widely used for strategic regional planning (e.g. (Viskari;Koutonen;Retkin;Heikkala;& Korkiakoski, 2020) (Pajunen, 2019) since 2017, with ca. 1500 users per year.

The [Biomass Atlas web map application](#) consist of a database and a user interface. The user interface offers a tool to explore different types of biomasses visually by means of thematic maps, conduct spatial analysis, and summarize mass amounts for selected regions on a map and export the results for later use. Data layers are also available via web map service (WMS) and web feature service (WFS) interfaces and can be downloaded as files. (Natural Resources Institute Finland (Luke), 2021).

The data is spatially harmonised to a 1-km grid, which enables fast functionality in the web service. All the data, features, and functionalities of the Biomass Atlas will be described in an article by Lehtonen et al. (in preparation).

Besides the map user interface, the [Biomass Atlas web page](#) describes the main biomass types, where they are formed, how they are typically used, and what kinds of possibilities there are for other uses. (Lehtonen, et al., 2017).

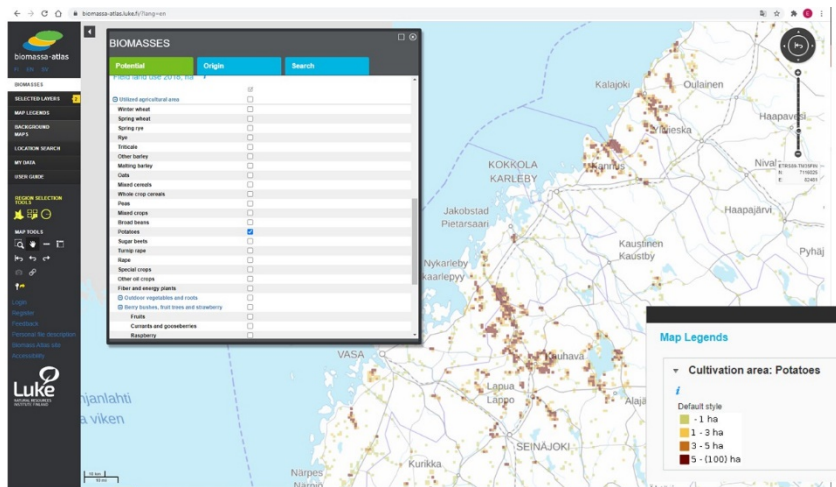

Figure A2. The Biomass Atlas user interface, map window, biomass selection tool, and a thematic map of the potato cultivation area.

Data set properties

Data is available for the whole Finland. Crop data in the Biomass Atlas describes the situation for a year. For field use, there are 49 data and map layers: the utilized agricultural area, winter wheat, spring wheat, spring rye, rye, triticale, malting barley, other barley, oats, mixed cereals, whole crop cereals, peas, mixed crops, broad beans, potatoes, sugar beets, turnip rape, rape, special crops, fibre and energy plants, outdoor vegetables and roots, garden pea, heading cabbages, other cabbages, carrot, beetroots (red and yellow), other beetroots, gherkin, onion, lettuce, berry bushes, fruit trees and strawberry, fruits, currants and gooseberries, raspberry, flowers and ornamental plants, nursery production, caraway, green manure sward, cultivated pasture, silage sward, hay, fresh silage sward, natural pasture, herbage seed production, set aside and uncultivated fields, green fallow and nature management fields, buffer zones and buffer strips. The unit is hectare [ha].

Data on field use in the Biomass Atlas originally comes from the IACS register, and the original plant codes are reclassified and field areas are joined in a 1 km x 1 km grid.

For crop production potential, the map and data layers are winter wheat, spring wheat, spring rye, rye, malting barley, other barley, oats, mixed cereals, whole crop cereals, peas, broad beans, potatoes, sugar beets, turnip rape, rape, oil linen, reed canary grass, caraway, pasture yield, silage sward, hay, fresh silage sward, herbage seed, garden pea, heading cabbages, other cabbages, carrot, beetroots (red and yellow, other beetroots, onion, gherkin, lettuce, fruits, currants and gooseberries, raspberry, strawberry. The unit is tons of dry mass per year [t(TS)/a].

Data on crop production potential originates from the IACS register of land use and the crop statistics of Luke. For each plant, the yield in each ELY Centre is joined to field area of the same plant and of the same ELY Centre to estimate the crop production potential in each grid cell, based on the crop area in that particular grid and the crop yield in the ELY Centre where the field is located. For those plants that are found in the Crop Statistics, the calculation is straight forward. For silages, hays, and grass from nature management fields, different types of estimates are used.

For crop production side streams, the map and data layers are cereal straw, stems from peas and broadbean, potato tops, sugarbeet tops, potential additional harvest of green manuring sward, straw of herbage seed crops, potential biomass of green fallow, biomass of buffer zone vegetation, and stems of oil crops. The unit is tons per year [t/a]. Side stream calculations are based on the crop production potential and plant specific harvest indices (Hakala, Kontturi, & Pahkala, 2009).

The amounts of biomass and side streams and the areas of fields are calculated for a 1 km x 1 km grid. It is possible to make map queries and obtain biomass summaries for selected areas. The selection options include freely selected areas, a central point with chosen radius as a circle radius or along a road network, or preselected areas. The pre-selected areas include Centres for Economic development, Transport, and the Environment (ELY Centres), municipalities, provinces, postal code areas, and drainage basins.

The Biomass Atlas was published 2017 with data from the previous year, and updates are carried out annually or when necessary.

The data descriptions i.e. metadata of the main biomass types are available via the national geoportal [Paikkatietohakemisto \(National Land Survey Finland, 2021\)](#).

Data access

Data can be explored in the Biomass Atlas web service (Natural Resources Institute Finland (Luke), 2021), which is open and free to use. There are WMS and WFS interfaces to obtain the data. Registered users can also download it. The data is licenced by CC4 by name.

Technologies

The register data for fields (IACS) comes to the Biomass Atlas from the Finnish Food Authority as text files, and crop statistics are requested from the API of Luke Statistics by JSON query. The data from two different sources are then combined according to the plant code and imported to the Biomass Atlas by batch processing. SQL syntaxes are used for different groups of field use and crops.

The Biomass Atlas database uses the Postgre SQL database system with PostGis extension. The WMS and WFS services are used to share the data in map format.

The Biomass Atlas system utilizes Oskari, which is a framework for building web mapping applications utilizing distributed spatial data infrastructures such as

INSPIRE. It is based on open-source components such as Open Layers, Geo Tools, and GeoServer. Oskari supports the EU directive INSPIRE and OGC standards.

Gaps and opportunities

The Biomass Atlas has improved the availability of spatially explicit data on field use and the biomass potential in Finland, and it also appears to be quite unique compared to data availability in other countries.

However, the lack of regular maintenance and updating protocols and their resources makes the system vulnerable. Data of current use of field biomasses would help to assess the real availability of field biomass. Also, more participatory and real-time methods of data collection and sharing would help to utilize the potential of crop side streams.

1.2. Crop-based products

[Statistics on cereals purchased, used, and stockpiled by industry and trade](#) published by Luke are quarterly statistics on the volumes of cereals, turnip rape, and oilseed rape purchased directly from farmers and the volumes used by the cereal industry. Biannual statistics on the stocks of cereals, turnip rape, and oilseed rape are held by enterprises that buy and use cereals. The statistics include data on the volumes of cereals purchased from farms.

The Finfood - Finnish Food Information publishes Forkful of Facts (Finfood, 2021), a yearly compilation of food statistics covering the entire food production chain, including food manufacturers by sector as well as import and export of foodstuffs.

The Finnish Cereal Committee (VYR) is a co-operation platform of the Finnish cereal and oilseed sector. It produces information on grain production and processing in Finland, such as a map of processing places. The map and other figures are in the form of reports.

1.3. Fertilizers

Description

All fertilizer products (fertilizers, liming materials, soil conditioners, substrates, microbial products) produced in, imported to, and marketed in Finland must be included either in the national type designation list of fertilizer products or, in the case of EC fertilizers, in the list of types of EC fertilizers designations specified in Annex I to EC Regulation 2003/2003. Fertilizers must also meet the requirements set out in the Finnish Fertilizer Product Act (539/2006). The Act ensures that all fertilizer products placed on the market in Finland are safe, of good quality, and suitable for plant production. There is no registration or approval process for fertilizer products, but the entrepreneur responsible for placing fertilizer on the market must

be registered. The data on fertilizer products are collected by the Finnish Food Authority, which is the supervising body for the production, marketing, and import of fertilizer products in Finland. The overall steering of the production, marketing, and import of fertilizer products and their monitoring belongs to the Ministry of Agriculture and Forestry.

Data set properties

The Finnish Food Authority upholds a register of activities involved in fertilizer manufacture for sale or release, the use of animal by-products (excluding manure), supplying for markets, and imports from inside or outside the EU. Using industrial by-products or other similar waste streams in fertilizer products is also considered as manufacturing and is monitored. Operators who only store, transport, or resell fertilizer products are not required to register. An exception to this is the storage of fertilizers of animal origin, which requires approval. The entrepreneur must supply the Finnish Food Authority with details of the purchases and origin of fertilizer products and their raw materials for traceability. The quantities of products manufactured, the deliveries of products and storage locations must be recorded. In addition, a record must be kept of the import and export volumes. The annual report is submitted to the Finnish Food Authority by all registered entrepreneurs in January of the following year.

The Finnish Food Authority is also responsible for paying and implementing subsidies to farmers funded by the European Agricultural Guarantee Fund, the European Agricultural Fund for Rural Development, and national funds. The application process for farmers is organized in an online service called VIPU. Subsidies are mainly based on the number of farm animals and arable land area. As part of the subsidy system, the majority of Finnish farmers have committed to a voluntary agri-environmental support scheme regulated by the Ministry of Agriculture and Forestry Decree on Environment Payments (327/2015), which requires very strict and field-specific bookkeeping of all cultivation measures (e.g., date of cultivation, sowing and fertilizing, cultivation method, crop species, amount and types of fertilizers used, liming, yield information). However, this large database remains hidden even from research, as the VIPU online system is open only for farmers, local advisory services, and municipal rural business authorities. Documents outside the online system concerning actual cultivation measures are kept in each farm for occasional monitoring purposes.

Data access

The Finnish Food Authority publishes a national register of operators in the fertilizer sector annually. The public list comprises the name, address, and industry (e.g., manufacturing, import) of the company, and, in the case of requiring approval, the approval number. Specific information on the fertilizer products and nutrient flows is not publicly available.

Statistics on mineral fertilizers sold in Finland are annually published by Natural Resources Institute Finland (Luke) based on information collected from Kemira Agro Ltd/Yara Finland Ltd, and fertilizer importing enterprises by the Finnish Food Authority. The data is published as kilograms of nutrient (nitrogen, phosphorus, potassium) per hectare of cultivated agricultural land (excl. fallow). Luke upholds the statistics on cultivated agricultural area (ha).

No similar dataset for other types of fertilizer products, such as organic fertilizer products, ashes, and soil conditioners, are available for open access. The Finnish Food Authority collects data on alternative fertilizers in annual reports, but it is not publicly available. It is used, for example, in the calculation of nutrient balances (nitrogen, phosphorus), indicating agricultural nutrient use efficiency. National nutrient balances are calculated annually in accordance with the calculation methods of Eurostat, resulting in nutrient balances for phosphorus and nitrogen (kg/ha; since 1995). Also, the use of mineral fertilizers is included in the nutrient balances. However, the datasets behind the resulting nutrient balances are not publicly available.

Fertilizer use data collected directly from farmers as part of the voluntary agri-environmental support scheme is used only for advisory and monitoring purposes and it is not available for other uses.

Technologies

Excel-based annual reports on fertilizer products are annually sent to the Finnish Food Authority, which makes the necessary compilations and forwards the data to permitted uses.

There is no information on the data collection systems of the entrepreneurs producing, marketing, and/or importing fertilizer products. Significant variation in data collection systems and the precision of the data is to be expected.

Future developments

The legislation on fertilization will be updated in Finland starting in 2021. The goal is to have the legislation ready by 2023, when the new CAP is implemented. The fertilizing limits are planned to be removed from the voluntary agri-environmental scheme and henceforth regulated by legislation.

Gaps and opportunities

The datasets on fertilizer products are scattered between the data collected and maintained by the entrepreneurs, the authorities monitoring their production, marketing and import, and the official statistics. From the viewpoint of a circular economy, a large part of the data is hidden either in the archives of the enterprises or in those of the Finnish Food Authority. A significant part of the data – fertilizer products actually used on farms – is not even available to research, although

farmers are obliged to record strict and field-specific measures as a condition for receiving EU agricultural subsidies.

1.4. Feed

Description

Approximately half of the produced grain yield (4 million tons of cereals and oil seeds) in Finland is used as animal feed (VYR, The Finnish Cereal Committee, 2020). Approximately 85% of the feed used for cattle, pigs, and poultry originates from Finland. Moreover, soy and other protein-rich plants are used for feed (Lihatiedotusyhdistys ry, 2018). A large part of the feed used is directly used on farms and data on the feed used remains on the farms.

Definitions related to feed can be found in the feed labelling [guide](#) of the Finnish Food Authority.

Data set properties

The Finnish Food Authority keeps statistics on the manufacture of feed materials. Feed materials of plant origin, animal origin, and other feed materials are reported in total and as amounts for the domestic market and for export. Direct domestic use is distinguished for the feeding of farmed animals, domestic animals, and wild animals. Amounts are reported in tons.

The data is based on annual declarations made by feed sector actors. The latest available statistics are from two years previously.

[Statistics are available](#) as pdf files.

The Finnish Food Authority compiles the statistics from annual feed declarations. A complete list of materials used for feed can be found in the EU legislation (EU 2017/[1017](#), part C) in the catalogue of feed materials. The main feed categories are as follows: 1) Cereal grains and products derived thereof, 2) oil seeds, oil fruits, and products derived thereof, 3) legume seeds and products derived thereof, 4) tubers, roots, and products derived thereof, 5) other seeds and fruits, and products derived thereof, 6) forages and roughage, and products derived thereof, 7) other plants, algae, and products derived thereof, 8) milk products and products derived thereof, 9) land animal products and products derived thereof, 10) fish, other aquatic animals, and products derived thereof, 11) minerals and products derived thereof, 12) products and by-products obtained by fermentation using micro-organisms, inactivated resulting in the absence of live micro-organisms, and 13) miscellaneous.

Manufactured feed and raw materials used for feed are reported by the places of manufacture. Imported feed is reported by the country of origin.

Data access

The statistics on manufacturing are available via the website of the Finnish Food Authority. Original declaration forms are held by the Finnish Food Authority in the form of Excel sheets.

Technologies

Data is requested annually from feed business operators in Excel sheets sent by e-mail or mail.

Gaps and opportunities

Data on feed materials can be used to model the circulation of nutrients and carbon in the food chain. If the feed consumption is known, the amount and properties of manure as well as feed waste can be better estimated.

Although the manufacture of feed materials can be traced originated to operators, and the destination of feed is requested, exact amounts of feed used on farms or at the regional level are unknown. Perhaps such amounts would be possible to model based on feed manufacturing, numbers of animals, and feeding recommendations. However, farms might have practises that differ from recommendations.

1.5. Feed waste and feed surplus

Estimations of excess silage and grass produced in nature management fields can be found in the Biomass Atlas, which is described in Appendix A, Section 1.15.

There are harvest losses of silage on fields, in storage, and when feeding cattle. Silage storage loss is typically 5–15% (Nousiainen et al 2010, p. 73, in (Puustinen, 2020)). Puustinen estimated silage losses to be 7.9% of feed dry matter in her thesis (2020), with 1.3% of losses consisting of natural degradation to gas and 6.6% consisting of silage spoilage. In addition, 3.7% of catered feed was not used by animals.

Feed eaten by ruminants varies considerably. There is more exact information on the feed for pigs and poultry, but waste and surplus amounts are difficult to estimate.

1.6. Livestock

The Finnish Food Authority keeps many different registers of animal keepers and shelters, livestock amounts, etc., which are mainly aimed to guarantee the safety of food production and avoid the spread of animal-borne diseases.

Natural Resources Institute Finland (Luke) keeps statistics on agriculture and production, including the number of livestock, with 13 statistical tables presenting

livestock numbers categorized by animal species, municipality, ELY Centre, herd size range, or by different year.

Description of animal registers

The register of animal keepers and holdings (shelters) is kept because the food production chain of animal origin can be monitored from start to finish. This ensures that food is safe and traceable throughout the production chain. In the case of serious animal diseases, it is essential to know the locations where the animal disease has been diagnosed. This also applies to recreational animals. The register can additionally improve the control of animal welfare.

The bovine register refers to the system used to produce and implement services required for the labelling and registration of bovine animals. All bovine animals born in Finland and imported to Finland are registered. Each animal must be uniquely identifiable. This is done by ear marks. Registry data is used primarily for preventing animal diseases, for traceability of animals and beef, and in the management of agricultural subsidies.

In addition, pig keepers must register the place where pigs are kept, and pigs must be marked either with a tattoo or an ear mark.

Poultry refers to all species of birds reared to produce meat, eggs, or other products, including broilers, laying hens, turkeys, geese, and ducks. They must all be registered. For each registered holding, a record must be kept of the animal species, categories of animals, and number of animals. In addition, records must be kept of animals entering and leaving the holding.

Bees, horses, camels, rabbits, sheep, goats, dogs, cats, frets, foxes, minks, and other animals are also registered. The complete list of animal registers can be found at <https://www.ruokavirasto.fi/viljelijat/elaintenpito/elainten-merkinta-ja-rekisterointi/> [in Finnish]

Sources of data

The Finnish Food Authority keeps the registers of animals. They include the number of pigs, bovines, poultry, sheep and goats, and horses kept on farms, the farm ID, and farm location. Pigs are listed by size, sex, and life stage, bovine animals by age, sex, and production type, and breed data also exist. Attributes of animals include the following:

- Bovine animals, aged less than 1 year
- Bovine animals, aged 1–2 years
- Male bovine animals, aged 2 years or over
- Heifers, aged 2 years or over
- Dairy Cows
- Non-dairy cows
- Piglets, less than 20 kg
- Pigs, from 20 kg to less than 50 kg

- Fattening pigs, 50 kg or over
- Breeding boars
- Breeding sows
- Sheep and Lambs
- Live goats
- Broilers
- Layers
- Other Chickens
- Ducks
- Turkeys
- Geese
- Equidae
- Other livestock

The registers are not openly accessible, as they contain personal data (farm location).

Data set properties

The animal group, species, purpose of animal keeping, and maximum capacity for animals are enquired for the register of animal keepers and holdings. The number of animals usually kept on the holding is also asked. The identification of the animal keeper is registered (personal ID, farm code or company ID), and for agricultural subsidies the registration is made using the farm code. The mode of operation, and starting and ending date of operation are stored in the database. Examples of the mode of operation include breeding, meat production, milk production, suckler cow production, keeping of companion and hobby animals, production of piglets, storage of gametes or embryos, and other modes. All animal species and modes of operation are listed in a [document](#) by the Finnish Food Authority.

The numbers of pigs, bovines, sheep, or goats are declared as exact numbers in their own registers. Declarations concerning events with bovine animals, such as calving, purchases, transfers, and imports from abroad, must be done within 7 days of the event. When a calf is born, the birth date, sex, race, and intended use are declared. The keeper must also keep an up-to-date list of animals by holding. The keeper can maintain the list digitally in the database of the Food Authority or the list can be maintained on paper at the farm. The paper list of animals must be kept for three years from the last date on which the animal was last marked on the list. The list contains information on the EU ID, ear number, name, date of birth, holder at birth, sex, breed, use, day of entry, previous holder, day and method of removal, next holder, information on the mother and father, reasons if not registered, and method of disposal. (Finnish Food Authority, 2021)

From the listed information, other variables such as age group can be derived. In addition, whether the breed is used for milking or meat production can be listed.

Data access

The key premise is that the rural business administration information system can only be used for the purpose for which the data were collected and stored. On the other hand, the documents of the authorities are public, which is based on the Act on the Openness of Government Activities. In addition to the Act on openness, the Personal Data Act applies to register data, because it is possible to join field data to farmer data, which is personal data. Therefore, it is possible to obtain the data for scientific research and the researcher in charge must ensure that the personal data is not disclosed to outsiders.

For research purposes, it is possible to ask the Finnish Food Authority to detach certain data from their register. Permission is first required. Usually, it takes several weeks to ask for and obtain the permission, and then later receive the data. A fee covers work expenses and is typically some hundreds of euros.

Future developments

Legislation on the identification and registration of animals changed on 21 April 2021, when EU Animal Health Code (EU 2016/429) and the acts adopted on the basis thereof became applicable.

The Food Safety Authority has a development project for a new bovine register, which will become operational in March 2022. There will be an interface for animal keepers as well as for authorities. The new bovine register will be based on architecture, where a Data Exchange Layer will enable stakeholders and authorities to undertake complex information processing and all actors will have equal opportunities to develop applications based on bovine data in accordance with the open data principle. The change to the new system is described in a report (Evira 2013). The new bovine register will also introduce the Suomi.fi credits, which will allow animal keepers to authorize other actors, such as a slaughterhouse, to act on their behalf. This will reduce the number of invalid registry entries.

Gaps and opportunities

Numbers of horses are only reported on farms. For other horses, only the housing sites are registered with the capacity and typical number of horses. From 21 April 2021, the new animal health regulations on animal housing and traceability oblige the operator responsible for the housing of horses to keep a record of the animals entering, born, dying, or leaving the housing. The records must show the number and identity of the equidae in the housing at any given time. The new regulation will result in more information on horse numbers and locations. However, the data is maintained at each housing location, and only presented to the authority upon request.

Fur animals are registered, but a significant number of fur farms are missing.

Description of animal statistics

Livestock numbers include cattle, pigs, poultry, and sheep and goats. Depending on the species, livestock numbers are recorded on 1 April or 1 May and on 1 December each year. The data is presented by ELY Centre and municipality. Information is also available according to other regional classifications and herd size. Information on the number of domestic animals is mostly obtained from registers.

Sources of data

See Appendix A, Section 1.1, Sources of crop production data.

Data set properties

The statistics are presented by ELY Centre and municipality and contain the numbers of cattle, swine, sheep, goats, poultry, and farm horses. The cattle statistics give a breakdown of the numbers of cows, suckler cows, bulls, heifers, and calves. The swine statistics show the numbers of sows, boars, fattening pigs, and piglets. The poultry statistics give a breakdown of the numbers of hens, chicks, roosters, broilers, turkeys, and other species.

The number of livestock on 1 April or 1 May and the number of cattle on 1 December are also available by other regional classifications and by herd size.

The classification of farms into regions is based on the municipality in which a farm's administrative centre is located.

Statistics on the number of domestic animals mainly include production animals on farms entered in the register of agricultural and horticultural enterprises. Registered farms include agricultural and horticultural enterprises, the financial size of which is at least EUR 2,000.

The number of poultry and horses on farms entered in the register of agricultural and horticultural enterprises (as of 1 April) is based on data collected from farmers in conjunction with the spring subsidy application.

Numbers of pigs on 1 April are taken from the Pig Register. The number of pigs on 1 December is drawn up using a sample of the data collected from farmers for the Farm Survey.

The numbers of cattle on 1 May and 1 December are taken from the Bovine Register as a complete enumeration, and the numbers of sheep and goats on 1 May are taken from the Sheep and Goat Register.

The statistics on cattle and pigs are drawn up twice a year, while the statistics for poultry, sheep, goats, and farm horses are drawn up once a year.

Data is available from the 1950s onwards.

Data access

Statistics on the number of livestock are public, open, and free to use. A reference worth mentioning is OSF: Natural Resources Institute Finland, Number of Livestock.

Technologies

Statistical databases are available at <https://stat.luke.fi/en/crop-production-statistics> with different options to explore, edit, and save the data as tables, figures, files, links, and html embeddings. Data can be downloaded as files or read through the PX-Web API (application programming interface) in the following formats: xlsx, csv, json, json stat, sdmx, and px.

There is also a web portal for statistical information. The figures in statistical websites are an example of PX-Web API implementation. The data behind the figures are loaded every time the web page is opened or updated, and when the database is updated, the figures are updated automatically.

1.7. Animal products

Luke statistics include yearly amounts for milk and milk products, meat production, and egg production in agricultural production statistics.

The Finnish Food Production Chain association publishes Forkful of Facts, a yearly compilation of food statistics covering the entire food production chain, including food manufacturers by sector as well as import and export of foodstuffs (Finfood, 2021).

1.8. Manure

Description

The Finnish national data on manure is produced in cooperation between Natural Resources Institute Finland (Luke) and the Finnish Environment Institute SYKE. The data is produced with a calculation tool called the Finnish Normative Manure System and it includes information on the quantity and composition of manure for different animal categories and manure types. The calculation is a mass balance starting from the excretion of animals and proceeding to the technologies and practices during animal housing and manure storage. Excretion calculations are performed by Luke with separate models for each animal category.

When the resulting manure data is multiplied with the statistics on the number of animals (1.7.6), data on manure produced in Finland can be obtained. Similarly, regional manure data can be obtained if the numbers of animals are divided according to the location of the animals (or animal farms). The Normative Manure System is not directly usable for farm-specific data provision, as it contains

information on average animal rearing and manure management for Finland instead of the specific choices made per farm.

Nevertheless, farm-scale data on the nutrient content of manure is a requirement for planning manure use as a fertilizer. For this, the farmer must have a manure sample analysed at minimum every five years or can choose to use the table values for manure nutrients given in the legislation (1250/2014; analysis is also still needed). The table values are derived from a large dataset of analysed manure samples from commercial laboratories (compilation by SYKE and Luke). Furthermore, manure quantity is not measured on farms, but they use minimum storage capacity requirements given in the legislation (1250/2014) to plan and build adequate storages. The capacities are based on a simplified calculation with the Normative Manure System.

Data set properties

The Finnish Normative Manure System is connected to the model calculating gaseous nitrogen emissions from agriculture (Grönroos, Munther, & Luostarinen, 2017). The model is used for annual inventoring and reporting of the emissions for the UN Convention on Long-range Transboundary Air Pollution (CLRTAP), the EU National Emission Ceilings Directive (2001/81/EC), and the UN Framework on Climate Change (UNFCCC). The model is updated irregularly as required and guided by the inventory protocol. The main responsible organization maintaining and using the model is SYKE.

No similar guidelines are available for the other sections of the Normative Manure System, but it has been developed using several different references and basic principles of mass balance calculations, as described by (Luostarinen, Grönroos, Hellstedt, Nousiainen, & Munther, 2017a) (Luostarinen, Grönroos, Hellstedt, Nousiainen, & Munther, 2017b) (Luostarinen, et al., 2017c).

The Normative Manure System may also be developed and updated by SYKE and Luke when required for its different uses or when new background data is available. However, no regular resources are available for this, and the work is carried out under different projects and/or other tasks of the organizations.

Data access

The information on manure quantity and properties as calculated by the Finnish Normative Manure System is openly available in three reports (Luostarinen, Grönroos, Hellstedt, Nousiainen, & Munther, 2017a) (Luostarinen, Grönroos, Hellstedt, Nousiainen, & Munther, 2017b) (Luostarinen, et al., 2017c), but the system itself is not. There is also no permanent location where the updated results would be made available. Their publication should thus always be organized separately until a proper solution is reached for how and where the new results are published after updates.

Animal statistics are collected and available as described in 1.6.

The manure analysis results of commercial laboratories are not openly available. The largest company, Eurofins, publishes some average data irregularly on its website. The original datasets may be purchased for given uses, such as the table values in legislation, but it must be ensured that no specific farms can be identified.

Technologies

The Finnish Normative Manure System is an Excel-based model, as are also the excretion calculation models per animal category. The background data for the system was previously collected by an electronic survey on manure management on livestock farms.

Future developments

The maintenance and updating protocols are being discussed and developed by Luke and SYKE, including the resources needed and their origin. The data produced is of vital importance for emission inventories from agriculture (greenhouse gases, gaseous nitrogen emissions, nutrient loading to waters), agricultural nutrient balance calculations (required by Eurostat), legislation regulating manure management and use on farms, and R&D work towards improved manure use efficiency.

Gaps and opportunities

Due to the data collection carried out by Luke and SYKE since 2010, manure data in the Finnish context is better than for many other organic biomasses and also better than in many other countries (e.g., in the Baltic Sea Region, (Luostarinen & Kaasinen, 2016). Nevertheless, the lack of regular maintenance and updating protocols and their resources makes the system vulnerable.

1.9. Slaughter waste and other side streams of animal origin

Description

Annually, over 250 000 tons of side stream of animal origin are formed in the meat industry. This category includes those parts of animals and products of animal origin that are not used for human nutrition: animals that die or are killed on farms, slaughter waste, waste from fisheries, fur animal bodies, and food waste of animal origin. An animal by-products regulation (EC 1069/2009) is applied to side streams of animal origin to ensure animal health and the safety of the food and feed chain. Based on EC and national laws (517/2015), the side streams are classified into three safety classes, and the possibilities to use side streams depends on the safety rules.

The YLVA database (described in Appendix A, Section 9.2) contains amounts of waste from industrial units where waste of animal origin is generated. European Waste Codes for animal tissue waste are those relating to animal-tissue waste from agriculture and forestry (02 01 02), animal-tissue waste from the manufacture of fish and meat products (02 02 02), and materials unsuitable for consumption or processing (02 02 03).

Honkajoki Oy is the largest company treating and refining the side streams of animal origin in Finland. At least 50% of the side stream goes to Honkajoki. Figure A3 describes the use of animal-tissue waste.



Figure A3. Use of animal tissue waste.

Data set properties

The main data source for side streams of animal origin is the YLVA database of the environmental administration of Finland. Some data can be also found from responsibility reports of plants processing animal-tissue waste (Honkajoki, 2020).

1.10. Food waste

Description

Food waste (FW) (Finnish: elintarvikejäte) is defined by the European Commission (2019/1597) as inedible (e.g., bones and peels of fruits) and edible food that is not utilized for human consumption, feed, or other value components. Edible food waste (Finnish: ruokahävikki) is originally edible food that is not utilized for human consumption, feed, or other value components (national definition). FW generation was estimated to total 643 million kg in 2019 in Finland.

The first complementary analysis of the amount of FW from the whole food chain of production and consumption was performed in the project of "Food waste monitoring and road map". A method to estimate food waste (solid and liquid) in all stages of food production and consumption was also developed in the project. The

sample sizes needed will be considered for future updates of the study. The results of the project enable food waste generation to be systematically followed and on a regular basis. (Riipi, et al., 2021) (Hartikainen, Riipi, Katajajuuri, & Silvennoinen, 2020).

The concepts of measuring FW have been defined at the national level, and a road map to diminish food waste in Finland was drawn up in the project.

The work is based on a European Commission statute draft about the measurement of food waste. The statute was approved as a delegated act for member states in May 2019. According to the statute, the member states have been required to report their food waste statistics to the commission since 2020.

Sources of data

Data summaries are presented in the tables of the project report (Riipi et al., 2021). The original data will be published later in scientific articles.

Data set properties

The data includes the amount of food waste and edible food waste in Finland in various parts of the food chain: primary production, the food industry, retail, food services, and households.

For food waste from primary production data is given for 17 indicator products that cover 97% of agricultural production in Finland. The products are wheat, barley, oats, rye, potato, sugar beet, carrot, strawberry, tomato, cucumber, beef, pork, chicken, eggs, milk, caught fish, and cultivated fish.

For waste from the food industry, the data is divided into six categories: 1) drinks; 2) dairy products; 3) vegetarian products and conservatives; 4) flour mills and bakeries; 5) meat processing and slaughter; and 6) other, including readymade foods, coffee, sugar, and sweets.

For retail waste, the data is divided into product sectors: 1) fresh vegetables, roots, potato, fruits, and berries; 2) fresh bread and bakery products; 3) meat, meat products, fish, and seafood; 4) milk and dairy products, cheese, fat, and eggs; and 5) others. Data is only given as percentages of food waste. Estimates are also provided for destinations and treatments of food waste.

In the food service sector, FW has been categorized into kitchen waste, serving waste, plate waste, and inedible food waste, and the data is given as the percentage of food produced and grams per customer in various branches: student restaurants, personnel restaurants, schools, day care centres, elderly care homes, hospitals, a la carte restaurants, hotels, petrol stations, and cafes, and for all branches together.

Household food waste was investigated with two methods: food waste diaries and sorting studies. The results are given as the amount per capita and according to the type of food.

Food waste data was collected in 2018–2019, but some of the figures used for calculations are based on older data.

The amounts are presented at an accuracy of 10⁵ kg/year (for primary production) and as a percentage (formed waste per produced or prepared amount of food; for primary production, the food industry). The percentage depends on definition of food waste and is given for three different definitions: EC, national, and FAO.

Data access

The report for the project “Food waste monitoring and road map” has been published and is available at: <https://www.luke.fi/ruokahavikkiseuranta/en/>

Technologies

Data on food waste from agriculture was collected from previous studies, the farm register, and literature values.

Retail food waste data was collected in cooperation with retail sector actors. Luke prepared a form for data collection and the Finnish Grocery Trade Association (Päivittäistavara-kauppa ry) collected the data from companies and aggregated the results.

Data on food service FW was collected in the form of a waste diary. A specific on-line data collection application, Lukeloki, was designed to steer catering personnel to input the same attributes of the data in the same format.

Questionnaires complemented the diary results and provided extra information on the reasons for food loss and methods to diminish the loss.

The food waste of households was examined in a waste sorting study and using a diary and questionnaire.

Future developments

Sampling for the first complete food waste research was not randomized, as participation was voluntary. In future studies, the sampling will be developed further. There are plans to make regular updates for the food waste data using the methods presented in the report. A delegated decision on the measurement of food waste (2019/1597) entered into force in May 2019. According to the decision, EU member states have been required to report their food waste to the Commission every year since 2020. Luke is Finland’s equivalent expert institution, which is responsible for reporting the food waste data of Finland to the European Commission.

One of the ways to improve the data could be the more holistic use of the information collected daily in markets. The estimates of food waste by consumers also need to be improved.

Gaps and opportunities

For some waste categories, absolute amounts are not given but only the percentage of waste generated. It is not always possible to differentiate between wastes originating from edible and non-edible food.

Most values are aggregated at the national level. Regional estimations might be possible if data on the population, companies, and agriculture is available and can be connected to food waste estimates.

1.11. Biowaste

Biowaste generated in municipalities is estimated in the Biomass Atlas based on census data of Statistics Finland and waste generated per capita. The Biomass Atlas is described in Appendix A, Section 1.1 and Section 1.15.

Biodegradable waste from companies and biodegradable waste from waste treatment plants is reported in the YLVA database, which is described in Appendix A, Section 9.2.

1.12. Sewage sludge

About one million tonnes of sludge per year is produced in water treatment plants according to Statistics Finland.

Sewage sludge from wastewater treatment plants is reported in the YLVA database, which is described in more detail in Appendix A, Section 9.2. The YLVA database contains generated amounts, but poor information on where the sludge ends up.

The Finnish Water Utilities Association (FIWA) is the co-operation and member association of the Finnish water and wastewater utilities, and it conducts a survey of wastewater treatment plants about the quality, treatment, transport, utilisation, and final disposal of sludge (Blomberg & Toivikko, 2015).

1.13. Processing of manure and plant waste

Processing of manure and plant waste mainly takes place in biogas plants. Data on the processing of manure and plant waste formed on farms is scarce and scattered. Environmental permits are one potential source of data, but the permit allows the treatment of different biomass types and processing can vary due to biomass changes. Therefore, environmental permits are more likely to provide data on the capacity of the biogas plant than the amounts processed or process operations.

1.14. Forest biomass, forest statistics

Description

The national forest inventory (NFI) produces data on Finnish forests based on measurements from a nationwide sampling site network with a good coverage over the land area of Finland (www.luke.fi. VMI). Finnish forest statistics (www.Luke.fi) compile various aspects related to forests and forest products.

The NFI is a continuously operating monitoring system that produces accumulating areal and nationwide information on Finnish forests, land use, forest health, biodiversity, carbon stocks, and carbon sinks. Finnish forest statistics 2020 is a compilation of key statistics on Finnish forests, forestry, and forest industries. It also includes statistics concerning the forest environment and forest protection. The annual growth of the forests is nearly 110 Mm³. A total of 73 million cubic metres of roundwood were harvested from Finnish forests in 2019. Between 2016 and 2019, an average of 91% of the sustainable yield of commercial timber and energy wood was harvested. The annual increment of the growing stock has clearly been higher than the total drain. Finnish forest statistics also provides comprehensive statistics on roundwood trade and roundwood removals. Additionally, wood consumption figures for the forest industries and energy industries are presented. Finnish forest statistics has a long history, dating back 50 years. Its content has been continuously developed to respond to growing needs for up-to-date information. For example, it can be used to monitor the sustainable use of forests and changes in forest carbon stocks. The forest statistics form part of the Finnish forest statistical system, which is of the best quality on a global scale.

The NFI and Finnish forest statistics are presented together here, because they support each other.

Sources of data

The Finnish forest statistics can be found in:

- suomen_metsatilastot_2020_verkko.pdf (luke.fi)
- [Suomen metsätilastot 2020](#) (2020)

and NFI results in:

- <https://www.luke.fi/tietoa-luonnonvaroista/metsa/metsavarat-ja-metsasuunnittelu/metsavarat/#:~:text=Valtakunnan%20metsien%20inventointi%20%28VMI%29%20on%20metsien%20ja%20mets%C3%A4varojen,metsien%20monimuotoisuudesta%20sek%C3%A4%20metsien%20hiilivaroista%20ja%20niiden%20muutoksista>.

Finnish forest statistics provides a comprehensive description of the Finnish forest sector and NFI produces original measured data and a time series of the properties of Finnish forests.

The data is collected by Luke (statistics and NFI) and owned by Luke. The purpose of the statistics is to extensively present the different sectors of forestry (list below).

Table of contents (Forest statistics):

- 1) [Metsävarat](#), Forest resources
- 2) [Metsien suojele ja monimuotoisuus](#), Forest protection and biodiversity
- 3) [Metsien hoito](#), Silviculture
- 4) [Puukauppa](#), Forest trade
- 5) [Hakkuut ja puuston poistuma](#), Harvest and timber removals
- 6) [Yksityismetsätalouden kannattavuus](#), The profitability of private sector forestry
- 7) Metsäsektorin työvoima, Forest sector labour
- 8) Metsäteollisuuden puunkäyttö, The timber use of the forest industry
- 9) [Puun energiakäyttö](#), The use of forest products as energy
- 10) [Metsäteollisuus](#), The forest industry
- 11) [Metsäteollisuuden ulkomaankauppa](#), The foreign trade of the forest industry
- 12) [Metsäsektori kansantaloudessa](#), The forest sector as a part of the national economy
- 13) [Kansainvälisiä metsätilastoja](#), International forest statistics

Many of the forest farms have forest management plans that provide a good description of the tree stand properties and the expected forest growth on a compartment level. This data is not public.

Data set properties

The data covers the whole land area of Finland, is published annually, and is freely available via the Internet, including figures and tables. NFI data accumulates annually, while forest statistics are supplemented annually. NFI data is based on original measurements, with the original data being used to produce more general tables, and the value of the data is ensured and the measurements are conducted following a strict protocol. Similar data is available over a number of decades, and for the NFI now covers a period of 100 years.

Data access

The data is open and free. When applied, the source of data needs to be mentioned.

Technologies

These comprise field measurements, forest data databases in Luke, and distribution via the Luke web pages. The data is refined in tables and figures complemented with explanatory texts (www.luke.fi) and <https://metsainfo.luke.fi/>.

Future developments

The NFI measurements and publication of Finnish forest statistics will continue and new properties will be added according to future needs. The utilization rate of the data is high, and the annual costs of the NFI are EUR 1.8 million.

Gaps and opportunities

The data can be used to develop new forestry products and to increase the degree of utilization.

1.15. Food system data service – the Biomass Atlas

Description

The Biomass Atlas is a web-based service that provides spatially explicit data on crop production and its side streams, manure, municipal biowaste, biodegradable waste of companies and public services, and forest cutting side streams at a 1 km x 1 km resolution. A description of the service is also given in Appendix A, Section 1.1 on field and crop data, but other data available in the Biomass Atlas is described below.

Data set properties

The service covers Finland with a 1 km x 1 km grid. The data has accumulated annually since 2016. The latest data is visible in the map application, but older datasets can be downloaded by registered users.

Manure – The calculation method is from Finnish Normative Manure system and is based on the animal amount, excretion factors, and fodders used.

Field use – Through the Integrated Administration and Control System (IACS) and land parcel identification system (LPIS), farmers annually report of their cultivation plan. The raw data is grouped into the main field use types.

Crop potential – Field use combined with crop statistics to form an annual potential for crop production.

Field side stream potential – A harvest index-based estimate of remaining part of the plant after the main crop is harvested. The potential is the theoretical yield of

the plant side stream, and reductions need to be made by user to acquire the technical or sustainable potential.

Separately collected biowaste from municipalities – Modelled using census population data and the average waste yield per capita.

Biodegradable waste from companies – From the YLVA database of environmental governance for the environmental licence administration.

Ashes from incineration plants – Also from the YLVA database.

Selected summaries from the multisource national forest inventory.

Forest chip potentials: small wood and branches of deciduous trees, pine, and spruce.

Data access

The service is available at: <https://www.luke.fi/biomassa-atlas/en/>

1.16. Calculation tool for regional nutrient and carbon recycling

The Nutrient Calculator is a tool for planning regional nutrient and carbon recycling. It contains data on nutrient-rich biomasses, their quantity, composition, and location, on three levels: national, regional, and municipal. The user can simulate biomass use by different processing techniques, choose different shares of the biomass for the processes, and simulate various end products. The biomass quantity and nutrients are provided after processing. Fertilization can be calculated in three different strategies: according to the environmental scheme, crop phosphorus requirement, or nitrates decree. The regional surplus or deficit in nutrients can be calculated as a comparison between nutrients in biomasses and nutrients given in fertilization. An estimate of nutrients bound in the crop yield is also available. The phosphorus balance is used for estimating the change in the soil phosphorus status.

The Nutrient Calculator tool was developed for authorities to enable planning and making scenarios. When aiming at improved nutrient and carbon recycling, the first prerequisite is to know the quantities and characteristics of recyclable biomasses available at a given location. Secondly, it is important to know how these biomasses can be handled and processed to promote the closing of material cycles.

2. Batteries – data through the battery value chain

Sonja Lavikko, Marjaana Karhu, Sari Kauppi, Ari Hentunen, Samppa Jenu

2.1. Regional State Administrative Agency, water and environmental permits information service

Description

The Regional State Administrative Agency provides a water and environmental permits information service. The information service provides a tool for searching water and environmental permit cases and related public documents for cases initiated, notified, and decided by the Regional State Administrative Agency.

Sources of data

The Regional State Administrative Agency provides a water and environmental permits information service. In this service, documents related to water and environmental permit cases concerning to by battery value chain actors can be searched for.

Data set properties

Environmental permits include data on raw materials, products, by-products, and production capacities. Data is also included on the main chemicals used in processing, process side flows, waste, and effluents (emissions to air).

Data access

In the Regional State Administrative Agency water and environmental permits information service, data is openly accessible and free of charge for public use. In the information service, water and environmental permit cases initiated, notified and decided by the Regional State Administrative Agency, and related public documents can be searched for. However, personal data and/or confidential information has been removed from the documents.

Technologies

Data not available.

Future developments

Data not available.

Gaps and opportunities

From the data, some confidential information might be removed, which is the one possible gap for open data access.

2.2. Registration, Evaluation, Authorisation, and Restriction of Chemicals (REACH)

Description

The European Union REACH legislation considers the registration, evaluation, permit procedures, and regulations of substances. The legislation obligates the manufacturers, importers, producers, users, and distributors. Hazardous chemicals intended for professional use or common consumption require a chemical notification submitted to TUKES. The notification is provided by the company producing a chemical for the domestic market or a Finnish company importing a chemical to Finland.

Sources of data

Collected data is submitted to the European Chemicals Agency (ECHA) by registering the substance. Registration concerns any producer importing substances to the EU or a manufacturer producing >1000 kg/year inside the EU.

Data set properties

Distributors are required to collect data on the features and uses of a substance they either manufacture or import. They are also required to evaluate the risks and hazards of the products, as well as to specify the requirements for the safe use of a substance. Notifications are submitted through the Kemidigi system.

Data access

ECHA supports cooperation in the field of chemicals regulation through involvement in several cooperation platforms and initiatives. Stakeholders are required to share data and work together.

Technologies

Data is collected by different stakeholders and combined by ECHA.

Future developments

By working together with stakeholders, including industry representatives and NGOs, authorities can help ensure the transparency and predictability of regulatory activities, and make sure that all parties are informed on the progress made in addressing particular groups of substances.

Gaps and opportunities

ECHA is actively aiming to avoid gaps, overlap, and duplication of data by working together with stakeholders.

2.3. Hazardous chemicals data by Kemidigi

Description

Kemidigi provides open access data on hazardous chemicals available on the Finnish market.

Sources of data

The data required from companies include import or production quantities as precisely as possible (in tons).

Data set properties

Data is collected annually. Authorities monitor the quality of the submitted data.

Data access

Registered companies and authorities have access to chemical data, their own information, notifications, and directories. Data is available to other parties upon request.

Technologies

Submitted data is used to evaluate the quantities of chemicals on the Finnish market.

Future developments

Regulations and permit requirements are updated according to need.

Gaps and opportunities

Data cannot be used to identify a certain company or a certain product.

2.4. Substances in Products in the Nordic Countries (SPIN)

Description

SPIN provides the quantities of substances openly available in the Nordic countries. The intention behind the SPIN database is to make available to the public as much data as possible from the registers.

Sources of data

The national product registers of Finland, Sweden, Denmark, and Norway.

Data set properties

Substance quantities on the market are updated annually. SPIN contains use information from several years.

Data access

SPIN is a free of charge, open access database.

Technologies

The SPIN database is available in an offline version and uses the Microsoft Access format. Four index tools have been developed:

- Use Index: A general estimation of emission/exposure to a chemical for different human and environmental target groups.
- Range of Use index: Indicates the broadness of use of a substance in a Nordic country.
- Article Index: Gives indications of whether a substance may end up as part of an article.
- Quantity Index: Based on the amount of a substance consumed annually.

All the data are summarized and no references can be made to specific concentrations of any given substance in any type of product. The summarized data in SPIN are in general based on the data in Nordic product registers.

Future developments

Data not available.

Gaps and opportunities

Non-chemical products are not included. For example, biocides and heavy metals contained in articles are not included in SPIN.

When the composition of a product is changed, the companies do often not report this to the product registers.

SPIN provides a rough estimation of the quantities used in different areas in the Nordic countries. The figures are not as accurate as the number of digits suggests, and when using them they should preferably be considerably rounded off. Secrecy rules have made it necessary to exclude data on many substances in SPIN. As a result of secrecy considerations, some substances in the Nordic product registers are only mentioned in SPIN by their name.

2.5. Substances of Concern in Articles as such or in Complex Objects (SCIP) Database

Description

SCIP is a database of Substances of Concern In articles as such or in complex objects (Products) that was established under the EU's Waste Framework Directive (WFD, EU 2018/851, amending Directive 2008/98/EC on waste). The objective is to prevent the generation of waste containing substances of concern. The further aims for the database are to ensure that information on hazardous substances is available for all (consumers, authorities, and other operators) throughout the whole life cycle of products and materials. It also aims to reduce the content of hazardous substances in products and materials while pushing for substitution of substances of concern. A further aim is to improve waste treatment operations and so contribute to managing hazardous substances in the circular economy.

European regulation on chemicals (Registration, Evaluation, Authorisation, and Restriction of Chemicals, i.e., REACH) includes guidance for producers and importers of articles to identify whether they have an obligation under REACH in registration and notification according to Article 7 and in relation to article supply chain communication according to Article 33.

Sources of data

The European Chemicals Agency (ECHA) established and maintains the database of SCIP notifications following Article 9(2) of WFD. Companies are required to submit information to the SCIP database when supplying articles containing substances of very high concern (SVHCs) on the Candidate List in a concentration above 0.1% by weight.

“The SCIP database has three main objectives: 1. Decrease the generation of waste containing hazardous substances by supporting the substitution of Candidate List substances in articles placed on the EU market. 2. Make information available to further improve waste treatment operations. 3. Allow authorities to monitor the use of substances of concern in articles and initiate appropriate actions over the whole lifecycle of articles, including at their waste stage.” (ECHA, 2020)

Data set properties

Companies need to submit information to ECHA when supplying articles containing SVHCs (0.1% w/w) on the EU market. It is possible to refer to the data that is submitted by a supplier or by the company. The information needed is the following:

- Identification of the article / complex object (brand or model names and public identifiers included)
- Identification, concentration range and location of the Candidate List substance(s) present in the article
- Information on the safe use of the article and sufficient information for the proper management of the article in the waste phase.

Data access

SCIP notification incurs a cost for the companies. The data is available for authorities, waste operators, and consumers.

Technologies

ECHA has provided IT tools such as an online tool (ECHA Submission Portal) to submit information on articles that contain a Candidate List substance at a concentration above 0.1% w/w.

Future developments

SCIP is regulated by the EU and so obligatory for any supplier.

Gaps and opportunities

The SCIP database is necessary for a future safe circular economy and safe and sustainable recycling processes of products and materials without severe hazardous substances.

2.6. Battery management system (BMS)

Description

Battery use phase data in the application of a battery is collected by a battery management system (BMS). The BMS monitors the state of the battery with direct measurements (e.g., cell voltages, current, power, temperature, energy throughput (kWh)) and calculates state estimates (state of charge (SOC), state of health (SOH), remaining useful life) and key performance indicators (KPIs) from the measured data. Some aggregated data is transmitted to the vehicle control unit (VCU), supervisory control and data acquisition (SCADA) system, or human-machine interface (HMI), typically via a data bus such as controller area network (CAN) bus.

The data originates from the BMS, which monitors, processes, and transmits the data. Besides the BMS, the data may be collected and stored by many instances and devices, such as:

- The battery supplier
 - access to the BMS in case of technical support or warranty claims
 - might have remote access to the BMS
 - might have a remote data connection and storage, e.g., to the cloud
- The vehicle manufacturer or system integrator
 - collected data in databases
 - control units and management systems such as the VCU or energy management system
 - data acquisition unit
 - might have direct access to the BMS data
- The end-user (vehicle owner/operator or stationary battery storage operator)
 - supervisory control and data acquisition (SCADA) system
 - in passenger cars and other consumer products, the user can typically see some battery status information such as SOC, SOH, or temperature, but cannot access the full spectrum of data from the BMS, CAN bus, or other systems
- The battery data analytics provider
 - data storage in the cloud
 - data-based battery monitoring, diagnostics, and analytics

Data set properties

The BMS monitors the battery with numerous direct measurements (e.g., cell voltages, cell or module level temperatures, current) on a time scale from tens of milliseconds to seconds. In most applications, it is not reasonable to collect and store all the measured data, but instead, the BMS sends some aggregated battery data (e.g., min/max cell voltages, pack voltage, min/max temperatures, current) and calculated state estimates (e.g., SOC, SOH) on a time scale from seconds to minutes to the VCU or SCADA system. This data can be stored at the vehicle/system level or at the fleet level in a cloud-based battery data platform.

Data access

The data is owned by the companies, and hence is not public.

Technologies

The BMS stores some historical usage data, but it is not capable of storing large amounts of data. In vehicular and industrial applications, the BMS typically sends processed data to the data bus, from which the VCU or SCADA can read the data that it needs for control and data storage. The BMS keeps track of battery system warnings and faults, along with some KPIs. In the most advanced systems, data is transmitted to a cloud-based battery data platform, which provides powerful data storage and analytics capabilities. Some companies already offer platforms for battery data monitoring, diagnostics, and analysis in the cloud.

Future developments

Advanced cloud-based data analytics platforms and services are currently being developed that can improve battery management and provide predictive maintenance. This results in a longer battery lifetime and may reduce the downtime of the battery system caused by malfunctions or scheduled maintenance.

The European Commission (EC) has prepared a proposal for a regulation of the European Parliament and of the Council concerning batteries and waste batteries, repealing Directive 2006/66/EC and amending Regulation (EU) No 2019/1020 (Battery Regulation). The proposal is very broad and addresses many aspects through the battery value chain, including:

- Traceability: battery composition and the origin of minerals must be available (Battery Passport)
- BMS data processing: key performance indicators are defined and their measurement method is specified in detail
- BMS data availability: selected battery usage data must be openly available from the BMS

- Second life and recycling: battery composition, SOH, and lifetime history must be openly available

Gaps and opportunities

Significant business opportunities are emerging in advanced cloud-based battery analytics and management. Some commercial platforms and services are already available, but the market is not yet fully established.

The closed data interface of the BMS severely limits the possibilities to explore the second-life possibilities of a battery after it has reached the end of life in the vehicle. In the battery refurbishment and second-life application segments, the vehicle OEMs have established partnerships with selected companies to provide refurbished batteries and second-life battery storage systems. The proposal for the Battery Regulation addresses this gap by obligating battery suppliers to partly open the BMS interface so that some of the battery usage history data will become accessible to all stakeholders.

2.7. Chemicals data by the Finnish Safety and Chemicals Agency (TUKES)

Description

The Finnish Safety and Chemicals Agency, or Tukes, is an agency within the Ministry of Employment and the Economy of Finland. Its task is to monitor and enforce safety and regulations compliance in technology, chemicals and hazardous materials, workplace safety, and consumer and product safety.

Sources of data

The data is collected from the Register for Market Surveillance maintained by TUKES.

Data set properties

Accessible information covers the past three years and is updated daily.

Data access

Some of the data provided by TUKES has been made open access and free of charge for public use. Open data includes information on hazardous products restricted by TUKES, as well as security releases, product recalls, and removals by the companies themselves.

Technologies

Data not available.

Future developments

The EU aims to guarantee the free movement of products by harmonising requirements for products.

Gaps and opportunities

Harmonised European requirements are not specified for all products.

2.8. Producer responsibility register by the Pirkanmaa Centre for Economic Development, Transport and the Environment (PIRELY)

Description

PIRELY maintains a platform for producer responsibility. Producer responsibility applies to all battery and accumulator importers and manufacturers in Finland. It also applies to batteries and accumulators imported to Finland that are included in vehicles (such as cars), as well as inside electrical and electronic equipment. Companies importing or manufacturing batteries and/or accumulators to Finland may comply with the producer responsibility requirements by joining a producer responsibility organization (Akkukierrätys Pb Oy, Suomen Autokierrätys Oy, Recser Oy, ERP Finland ry). By joining a PRO, a company ('producer') may transfer its producer responsibility obligations for the PRO. PROs report to the Pirkanmaa Centre for Economic Development, Transport and the Environment.

Sources of data

PIRELY maintains a platform for producer responsibility that lists producer responsibility organisations (PRO) and information on their members. PROs collect data on the quantities and compiled statistics of batteries, monthly scrapping statistics, and a collection point register (Table A2.).

Data set properties

PIRELY reports the quantities of batteries and cells imported and collected in Finland to the European Commission. Producer responsibility in Finland is based on the Waste Act (646/2011), as well as on the Government Decree on Batteries and Accumulators (520/2014).

Data access

Data availability differs between PROs (Table A2.). Producer listings are openly available. Producer reports and details are processed confidentially and securely and are not therefore openly accessible.

Table A2. Data availability of Producer Responsibility Registers.

PRO	DATA COLLECTED	DATA AVAILABILITY	OTHER
AKKUKIERRÄTYS PBOY	Producer Register Collected and compiled statistics on batteries	Open access to Producer Listing	Producer reports and details are processed confidentially and securely
SUOMEN AUTOKIERRÄTYS OY	Producer Register Monthly scrapping statistics	Open access to Producer Listing	
RECSER OY	Producer Register Collection Point Register	Open access to Producer Listing and Collection Points	Producer reports and details are processed confidentially and securely
ERP FINLAND	Producer Register Collected Quantities	Open access to Producer Listing	

Technologies

Data not available.

Future developments

Data not available.

Gaps and opportunities

Detailed information is not publicly available. There are no producer responsibility organizations for lithium-based starter batteries or electric motorcycle traction batteries.

2.9. International waste transfer data by the Finnish Environment Institute (SYKE)

Description

The Finnish Environment Institute is a research institute and government agency under the Ministry of the Environment. SYKE monitors international waste transfers in Finland.

Sources of data

SYKE requires waste transfer permits from the operatives handling the transfer and environmental permits from the operatives receiving the transfer. The data and information are produced and collected mainly by the organizations of environmental administration, especially the Finnish Environment Institute (SYKE) and Centres for Economic Development, Transport and the Environment (ELY Centres).

Data set properties

Open access lists for valid TFS notifications are available for the past year.

Data access

The international waste shipments system (Finnish: TFS) publishes open access lists for valid TFS notifications. Data is accessible by utilizing web services, spatial datasets, and satellite observations, as well as data stored in environmental information systems. Environmental data can also be viewed in various web map applications.

Technologies

Descriptions of different datasets and data systems can be viewed in the metadata portal. A Creative Commons Attribution 4.0 International license for open datasets allows users to distribute, remix, tweak, and build upon others' work, even commercially, as long as they credit the original creation. The source references for credits can be found in the metadata of each data product.

Future developments

Data not available.

Gaps and opportunities

Data not available.

3. Textiles

Pirjo Heikkilä, Helena Dahlbo, Tiina K. M. Karppinen

In 2021, SYKE led a mapping survey of the textile flows in Finland (3.1). Conducting such survey was not an easy task, since even though some waste management-related data is gathered (3.2 and 3.3), there is no systematic collection of all the data needed for such mapping. Furthermore, information was collected from various sources, and one challenge is that some data sources indicate value (in euros) and others weight (in kg/tons).

These same challenges apply to circular textile data and information in general. Very few data sources are systematically collected and automatically updated. Information is generated periodically, for example, by textile organizations such as Finnish Textile & Fashion (3.4) or Euratex (3.5), or produced within surveys and projects when funding for these is available, for example, the textile flow survey (3.1), Telaketju projects (3.6), and Nordic research collaborations (3.7).

3.1. Textile flow survey 2021

Helena Dahlbo

Description

The Textile flows in Finland – update for the 2013 survey is a project funded by the Ministry of the Environment, Suomen Tekstiili ja Muoti ry, ETU ry, KIVO ry, and the Finnish Environment Institute SYKE (Finix project). The project is coordinated by SYKE and carried out in co-operation with Turku AMK and Lounais-Suomen Jätehuolto Oy.

The 2013 survey (Dahlbo et al., 2015, Dahlbo et al., 2017) was based on 2012 data, which has now been updated using 2019 data. The survey followed the methodology developed in several previous Nordic studies (Tojo et al., 2012, Watson et al., 2018).

Sources of data

The data will be reported in the project report (currently being prepared, 15.4.2021). The report will be published in the publication series of Turku AMK.

The textile flows cover the supply of textiles in Finland ((domestic production+import)-export) and the flows of used textiles (reuse in Finland, reuse abroad, recycling, incineration).

Data set properties

The data covers the Finnish textile flows in 2019. For some of the flows, the most recent data originated from 2018. In these cases, the validity of this data for 2019 was estimated and when relevant was applied for 2019.

Data access

A public report is available at: <http://julkaisut.turkuamk.fi/isbn9789522167873.pdf>

Technologies

Data was collected from various sources by different organisations and combined by SYKE.

The supply was calculated based on statistics on the production of domestic textiles in the Customs database (Uljas). The flows of used textiles were obtained from questionnaires to charity organisations and other operators collecting used textiles separately. Additionally, data from laundries on used textile flows was collected with questionnaires.

Future developments

The data includes several sources of uncertainty, which are described in the report.

Gaps and opportunities

There is no continuous collection system for this data.

3.2. Textile waste in municipal waste statistics

Tiina K. M. Karppinen

Description

End-of-life phase data on textiles can be found from the national compliance database for environmental permit monitoring (YLVA) (Ministry of the Environment, 2021a). Textile (200111) and clothing (200110) waste from municipalities have individual codes in waste categorisation. This data is available upon request and for a service fee from the Finnish Environment Institute SYKE.

In addition to source-separated waste streams, textile waste ends up in mixed municipal solid waste (MSW). In Finland, mixed MSW is incinerated. National data is available on the consistency of mixed MSW from Finnish households, where the mass-based share of textiles can be seen.

More information on the data sources regarding waste in Finland can be found from Appendix A, Chapter 9.

Sources of data

The YLVA database collects data on waste from actors who have environmental permits. Most of national waste streams are found in the YLVA database. The waste-related data in YLVA is mostly public. It is available for monitoring purposes directly and for other purposes somewhat modified and upon request.

An organisation for public waste management in Finland governs a database on the consistency of mixed MSW from Finnish households (Suomen kiertovoima ry KIVO, 2021). The database is intended for summarising and collecting the different picking analyses to provide open and high-quality data. It is based on a national suggestion for carrying out picking analyses for mixed MSW.

Data set properties

YLVA includes data on waste streams arriving to or leaving treatment, as well as storage. The waste is categorised according to EWC waste codes, and the type of treatment also follows a standardised categorisation. The database is constantly updated with new data.

The data on the consistency of mixed MSW is based on individual picking analyses carried out by public waste management companies in Finland, following a harmonised method. The analyses considered in the national estimate are going through a manual quality check. The national estimates currently available are based on four picking analyses carried out in 2015–2019. Carrying out picking analyses and providing the data to the database is voluntary and based on individual development projects.

Data access

The waste-related data in YLVA is mostly available to the public upon request and for a service fee.

Data on the consistency of mixed MSW is publicly available free of charge, including both the national estimates and individual reports.

Future developments

There is an ongoing broad development project in the administration to improve the data systems for material and waste streams. The YLVA database will also be further developed.

In the future, there is also a need to monitor the consistency of mixed MSW from other sources than only from households, such as stores and offices.

Gaps and opportunities

Textile waste is a broad category that does not differentiate between the plethora of materials used in textiles. Also, the waste statistics do not directly account for textile waste found in mixed waste fractions or reused textiles.

3.3. Monitoring of reused textile products under the EU Waste Framework Directive

Tiina K. M. Karppinen

Description

The member states were required to begin monitoring the reuse of certain products, including textiles, in 2021 according to the revised EU Waste Framework Directive (COM-2018-98, 2018). Until now, there has been no continuous monitoring of the reuse of textiles. The Finnish Environment Institute SYKE is developing methods for monitoring the reuse of textiles. The monitoring will cover textiles sold or given away for secondary use by actors, such as recycling centres, auctions, and second-hand shops, as well as online marketplaces. The monitoring will not cover all actors in such fields. It will be based on sampling. The monitoring data will be made publicly available. (Koskinen, 2021)

Sources of data

As part of the EU Waste Framework reporting, monitoring of reuse will be used to evaluate the development in Finland, as well as in the EU. The data will be available via public websites or databases.

Data set properties

The national data will be updated every three years. The data sets will provide data on reused textiles in masses. SYKE is responsible for both the collection of data and reporting to the EU. The data will be available in a database based on the Harava system, from which the data can be retrieved as csv or Excel files.

Data access

The data sets from the EU Waste Framework reporting will be open to the public free of charge. The background data potentially concerning individual actors will not be public.

Gaps and opportunities

The monitoring of textile reuse only accounts for some of the streams and cannot so far provide a full picture of all streams of reused textiles.

3.4. Statistics by Suomen Tekstiili & Muoti (STJM)

Pirjo Heikkilä

Description

STJM is the central organization for textile, clothing, and fashion companies in Finland. It maintains statistics on the textile sector at the national level: <https://www.stjm.fi/julkaisut-ja-tilastot/tilastot/> The statistics include the following:

- The number of companies, turnover, and personnel: <https://www.stjm.fi/julkaisut-ja-tilastot/tilastot/tekstiili-ja-muotialan-yritysten-lukumaara-liikevaihto-ja-henkilosto/>
- Textile exports and imports: <https://www.stjm.fi/julkaisut-ja-tilastot/tilastot/vienti-ja-tuonti/>
- How much money people use on textiles: <https://www.stjm.fi/julkaisut-ja-tilastot/tilastot/rahankaytto-tekstiiliin-ja-muotiin-suomessa-ja-euroopassa/>
- Global fibre production: <https://www.stjm.fi/julkaisut-ja-tilastot/tilastot/kuitujen-tuotanto/>

In addition, STJM has a service allowing its member companies to be searched by name, location, or product category: <https://www.stjm.fi/liitto/jasenyritykset-toimialoittain/>

Owner: Suomen Tekstiili & Muoti

Sources of data

Sources are identified on the STJM website for each statistic.

Data set properties

Data properties are identified on the STJM website for each statistic. Most of these are updated annually.

Data access

Public, open access, free.

Technologies

Reports are available in pdf format.

Future developments

Updated annually.

Gaps and opportunities

Gaps include slow updating and low resolution (detail) of the data

Opportunities include a good overview of the textile sector and its volumes, customers, and actors.

3.5. Statistics and analyses by the European Apparel and Textile Confederation - Euratex

Pirjo Heikkilä

Description

Euratex is the central organization for national textile, clothing, and fashion organizations in Europe. It maintains statistics on the textile sector at the European level (including Finland): <https://euratex.eu/statistics/>

Statistics include:

- Key facts and figures: <https://euratex.eu/facts-and-key-figures/>
- Economic analyses and updates

Owner: Euratex

Sources of data

Sources are identified on the Euratex website for each statistic.

Data set properties

Data properties are identified on the Euratex website for each statistic. Some of these are updated annually.

Data access

Public, open access, free.

Technologies

Reports are available in pdf format.

Future developments

Statistics are updated annually. New analyses are published sporadically.

Gaps and opportunities

Gaps include slow updating and low resolution of the data.

Opportunities include a good overview of the textile sector and its volumes, customers, and actors.

3.6. Telaketju Research Activities Research Data via the Telaketju webpage

Pirjo Heikkilä

Description

Telaketju is an active network of actors aiming for better circularity of textiles in Finland. The website of Telaketju activities can be found at: www.telaketju.fi / <https://telaketju.turkuamk.fi/>. It contains research results in the form of reports, webinars, presentations, etc., prepared within different Telaketju projects, as well as links to research reports and other materials prepared by others. Projects that have contributed to public knowledge include:

- Telaketju YM (funded by the Ministry of the Environment) 2017–2018
- Telaketju Tekes (funded by Tekes) 2017–2019
- Telaketju TEM (funded by the Ministry of Economic Affairs and Employment) 2018–2020
- Telaketju 2 BF (funded by Business Finland) 2019–2021

Materials and links include the following:

- Final reports of Telaketju first-stage projects: Telaketju Tekes project 2019 <https://cris.vtt.fi/en/publications/telaketju-towards-circularity-of-textiles>, Telaketju YM project 2019 <https://storage.googleapis.com/turku-amk/2019/07/telaketju-ym-kokeiluhankkeen-loppuraportti.pdf> and Telaketju TEM, 2020 <https://telaketju.turkuamk.fi/uploads/2020/09/a90428d0-telaketju-tem-hankkeen-loppuraportti.pdf>
- Report on the suitability of different textile fractions for recycling processes (2019, Telaketju Tekes, in Finnish) <https://cris.vtt.fi/en/publications/tekstiilimateriaalien-soveltuvuus->

[kierr%C3%A4tykseen](#) (summary in English in the Telaketju Tekes report - see above)

- Report on risks and risk management on textile recycling (2019, Telaketju Tekes, in Finnish) <https://www.vttresearch.com/sites/default/files/pdf/technology/2018/T343.pdf> (summary in English in the Telaketju Tekes report - see first bullet)
- Report on economic modelling of textile collecting, sorting and recycling (2019, Telaketju Tekes, in Finnish) <https://cris.vtt.fi/en/publications/tekstiilikierr%C3%A4tyksen-prosessien-kustannusmallinnus> (summary in English in the Telaketju Tekes report - see first bullet). NOTE: the model is to be updated in the Telaketju 2 project
- Description of the concept for a national textile waste collection system in Finland (2020, Telaketju 2 BF & Telaketju TEM,) https://telaketju.turkuamk.fi/uploads/2020/08/5d8cc5d4-poistotekstiilin-valtakunnallinen-kerays_lsjh.pdf and https://telaketju.turkuamk.fi/uploads/2020/08/0c08d295-national-collection-of-end-of-life-textiles-in-finland_lsjh.pdf

The authors are indicated in each report. More information is available from the project manager, Pirjo Heikkilä.

Sources of data

Reports on research carried out in different Telaketju projects. The sources of data differ between the reports.

Data set properties

Reports on different topics. The origin and collection of data depends on the report. The data is not updated systemically. The data is not standardized and has been produced by normal project work with related quality control (according to the project group's best understanding at the present time).

Data access

Public, open access, free

Technologies

Reports based on research carried out in different Telaketju projects. Not updated systematically.

Future developments

More reports on different topics are to be included for as long as Telaketju activities are ongoing.

Gaps and opportunities

Gaps include the data not being updated systemically and only covering selected topics from the project.

Opportunities include the inclusion of new research results on topics that are not yet widely studied.

3.7. Nordic cooperation in textiles

Tiina K.M. Karppinen

Description

Under the Nordic Council of Ministers, Nordic cooperation has carried out in a number of surveys and projects related to textiles in the Nordic countries. The topics of the projects range from textile waste prevention, indicators, and recycling to commitments and ecolabels. The results of the most significant projects from a global perspective have been collected in the United Nations' One Planet best practices database under the umbrella of the Nordic Council of Ministers (<https://www.oneplanetnetwork.org/value-chains/textiles>).

Sources of data

The projects are carried out by the Nordic Council of Ministers to promote sustainability in the Nordic region and beyond. The results are open to the general public free of charge.

Data set properties

There are no official, updated data sets from the projects. However, a lot of data, including quantitative data, has been collected in the projects. For example, an overview of European and global markets for used textiles and estimates of the amounts of used textiles exported from the Nordic region can be found from the reports.

Data access

All of the project reports are publicly available.

Future developments

Circularity in the textile industry is still a high-priority theme in Nordic cooperation. More research and development projects on the topic are expected.

Gaps and opportunities

There are no actual databases in which data would be easily accessible. All updates of the data rely on project activity.

4. Primary mineral raw materials and mining waste

Jussi Pokki, Pasi Eilu, Svetlana Sapon

4.1. Mineral deposits and mines

Description

The Mineral Deposit database of the Geological Survey of Finland (GTK) contains data and information on mineral deposits and mines in Finland. It covers both metallic and industrial mineral deposits, including precious stones and industrial rocks. It does not cover soapstone, other dimension stones, sand, gravel, clay or comparable earth materials, or peat.

For each mineral deposit, there is a publicly available pdf report that contains the same information as the database. These mineral deposit reports can be downloaded by using a free data product called **Mineral deposits**. In these reports, data is divided under seven sections: General information, Geology, Exploration, Resources and reserves, Mining, Figures, and References. A second public data product, called **Mines**, only contains those deposits that have been mined or are currently being mined (or are mine projects being developed into operating mines). The data product Mines does not provide access to the pdf reports.

Sources of data

The data in the Mineral Deposit database is owned by GTK. However, the database also contains copies of images and original reference documents, and these files originally produced by other organisations are not owned by GTK. The data in the data products 'Mineral deposits' and 'Mines' can be 1) viewed in GTK's web service 'Mineral Deposits and Exploration' in a web browser, or 2) the data can be downloaded and viewed in GIS software:

- 1) As a user, enter GTK's web service 'Mineral Deposits and Exploration' at <https://gtkdata.gtk.fi/mdae/>. There, the mineral deposit layers can be found by following the path Mineral deposit and mines / Mineral deposits. The mine layers can be found by following the path Mineral deposit and mines / Mines. Check the check boxes in order to see the desired layers in the map view.

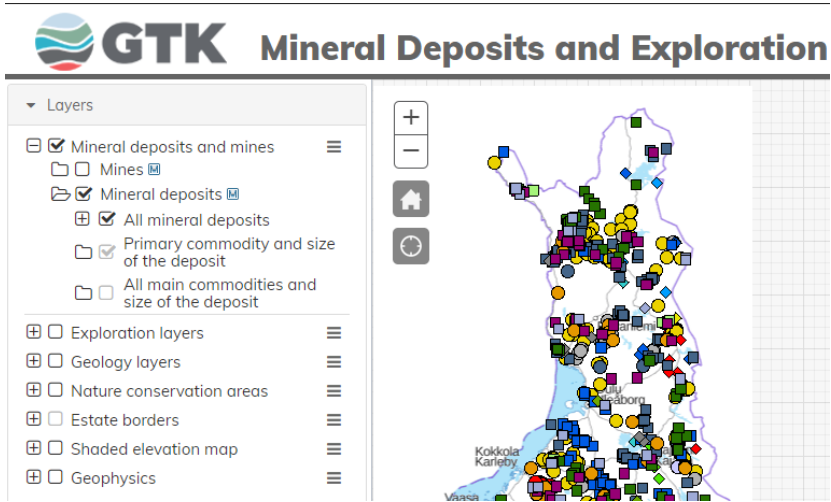

Figure A4. Information on mineral deposits and mines in Finland can be viewed in a web browser from GTK's public web service 'Mineral Deposits and Exploration' at <https://gtkdata.gtk.fi/mdae/>.

- 2) As a user, enter GTK's web service Hakku at <https://hakku.gtk.fi/en/locations/search>. To locate the product, scroll down the product list or write "Mineral deposits" or "Mines" in the search field.

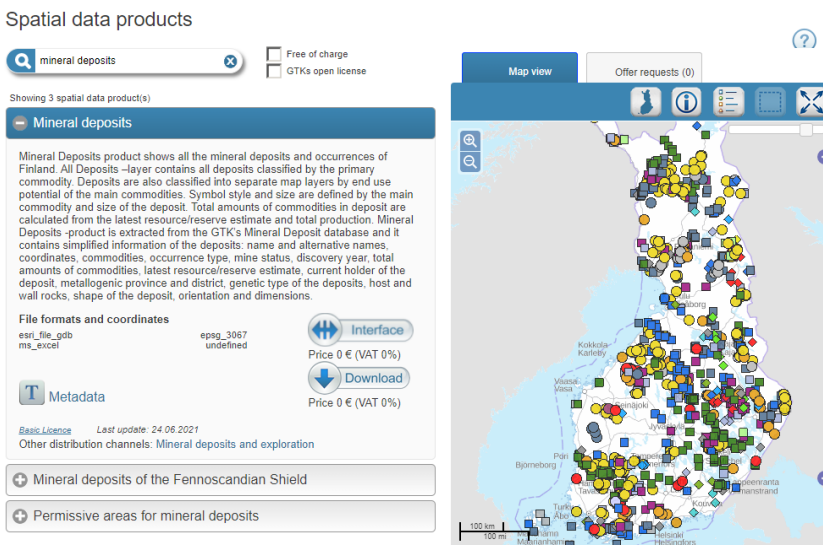

Figure A5. The data products 'Mineral deposits' (in the image) and 'Mines', as well as several other data products, can be downloaded from GTK's web service Hakku at <https://hakku.gtk.fi/en/locations/search>.

GTK's Mineral Deposit database is a state-of-art database on mineral deposits in Finland. It has been designed to facilitate access to a wide range of different information on each mineral deposit. The database can be used, for example, to find an answer to a simple question (e.g., How much nickel did the Kevitsa mine produce in 2015?) or to compile a synthesis table to show aggregated mineral resources of Finland for different commodities in the UNFC resource classification.

Data set properties

GTK's Mineral Deposit database currently contains information on over 1200 mineral deposits in Finland.

The data product **Mineral deposits** contains three layers (Figure A4) (in fact, one layer and two group layers): When zoomed into a relatively large area, only the layer 'All mineral deposits' is visible. It shows all mineral deposits, each classified by its primary commodity (e.g., a nickel deposit, an apatite deposit). When zoomed into smaller area, this layer disappears, and a group layer 'Primary commodity and size of the deposit' becomes visible. In this group layer, the deposits have also been classified according to the primary commodity, but these primary commodities have been grouped into eight categories (e.g., base metals, precious metals, industrial minerals). In addition, the size of each deposit is indicated in classes that are based on the sum of the latest resource estimate (total reserves and resources) and the production in the past. The user can hide this group layer and add into view a group layer 'All main commodities and size of the deposit'. This is in many ways similar to the previous group layer, but here a deposit can also be found under its other main commodities in addition to the primary commodity. For example, the primary commodity of the Kevitsa deposit is nickel and Kevitsa's main commodities are nickel and copper. Therefore, in the former group layer, Kevitsa can only be found under nickel, but in the latter group layer, it is under both nickel and copper.

By clicking on the symbol for each deposit in the map view, a user can open an information box containing attributes describing the deposit. For each deposit, there is a separate pdf report that contains all the information stored in the database on the deposit in question. This pdf report can be downloaded via the link 'Report' in the top part of the information box (Figure A6). The link related to, for example, the Kevitsa deposit opens the file http://tupa.gtk.fi/kartasovellus/mdae/raportti/12_Kevitsa.pdf. For mined deposits, the pdf report also contains mining data. However, the data product 'Mines' does not contain a link to the pdf reports. Therefore, a user can find more data on mining in the data product 'Mineral deposits' than in the data product 'Mines'.

The information boxes of the 'Mineral deposits' product facilitate the following 31 attributes (however, information has not been entered for all the attributes for all deposits): name, [primary] commodity, alternative names, current holder, occurrence type, all main commodities, other commodities, commodity measure total, deposit type, host rocks, discovery year, resources, reserves, size by commodity, mine status, calc[ulation] method [of the resources], calc[ulation] year

[of the resources], province, district, wall rocks, deposit shape, dip azimuth, dip, plunge azimuth, plunge dip, length m, width m, thickness m, depth m, easting EUREF, and northing EUREF.

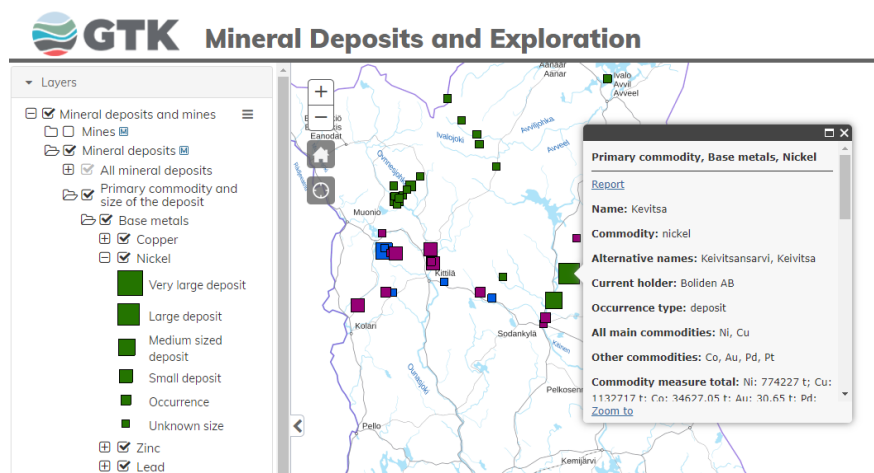

Figure A6. The information box of each deposit facilitates 31 different attributes. By clicking on the link 'Report', a user can open a pdf file containing all the information stored in GTK's Mineral Deposit database on the deposit in question.

The data product **Mines** contains the group layers 'Metallic mines' and 'Industrial mineral mines'. Both have been further divided into four categories: active mines, closed mines, historic mines, and mines under development (= projects being developed into operating mines). These, in turn, have been divided into categories based on the primary commodity of the deposit. The deposit size is indicated in classes based on the sum of the latest resource estimate (total reserves and resources) and the production in the past.

By clicking on the symbol for each mine, a user can open an information box facilitating the following 25 attributes (however, not all of them have been filled for all deposits): mine name, mine alternative names, mine status, current holder, main commodities deposit, other commodities deposit, production, size by main commodity, mining started, mining ended, years mined, resources total, reserves total, mine commodity mined, total ore mined, total ore processed, total waste mined, calculation method [of the resources], calculation year [of the resources], deposit name, easting EUREF, northing EUREF, easting YKJ, northing YKJ, and date updated. More extensive coverage of mining data is available in the pdf reports that can be accessed via the data product 'Mineral deposits'.

Data access

A so-called Licence 1 (Basic licence version 1.1; 28.9.2016; see http://tupa.gtk.fi/paikkatieto/lisenssi/gtk_basic_licence_1.pdf) regulates the terms of use for the data. The data is publicly available free of charge. However, the data is not open, because it can only be used for certain personal purposes or for internal use within an organization. Everything other than internal use, including the use of material 'as is' or as a part of the user's own products, such as maps, publications, books, brochures, advertisements, multimedia, or any other kind of use without the advance permission of GTK is prohibited. In documents created for authorities and in scientific publications and teaching materials, it is allowed to use images created from the material without separate permission. When using the material, the original source and the revision year of the material must be mentioned in the service that uses the material or a part of it. The material is to be marked as either presented as is or modified.

Technologies

GTK personnel store the data on mineral deposits in GTK's Mineral Deposit database by using the METSO interface specifically designed for this purpose. The database is part of a larger entity called the Geodata system. The METSO interface can be only accessed through GTK's intranet. Different portions of the data in the Mineral Deposit database are publicly available via several distribution channels: The spatial data products 'Mineral deposits' and 'Mines' are geodatabase files that are distributed as zip files in the Hakku service. The content of these data products is also available in the interactive web map service 'Mineral Deposits and Exploration', which can be viewed in a web browser. This web map service also contains a large number of other layers relevant to the subject. Some of these layers utilize data that other organisations feed into an interface for others to use.

For each mineral deposit, there is a publicly available pdf report that presents all information stored in the Mineral Deposit database on the deposit in question. These pdf files are automatically generated. Each time any information for any deposit is updated, the system automatically generates an updated pdf file for this deposit.

Future developments

It has been planned that a layer visualising mineral resources reported in the UNFC reporting code will be added in the Mineral Deposits and Exploration web service. This information is already present in the Mineral Deposit database itself. Also, keeping the attribute field 'current holder' updated for each mineral deposit will be automated. The MDaE is one of GTK's most used web services.

Gaps and opportunities

Data on mineral deposits and mines mostly describe what could potentially enter the circular loop in the future (reserves, resources) and, to a smaller extent, what has already entered it (mineral and metal production). Apart from mining wastes (Appendix A, Section 4.2), the Mineral Deposit database is focused on primary mineral raw materials and primary production, leaving the connection to the circular economy quite thin. It takes a considerably long period until these materials reach the end-of-life status and are available for recycling in the context of the circular economy.

Non-public data is not stored in GTK's Mineral Deposit database, because all data in the database is publicly available as mineral deposit reports in pdf format.

Major data gaps exist with following items (e.g., Eilu, et al., (2021)):

- What are the contents of battery metals in known mineral deposits and occurrences? Concerning battery metals, the best data coverage is for nickel.
- What are the contents of possible by-product metals (battery and other critical metals) in known deposits?

4.2. Mining waste

Description

Mining waste refers to mineral waste formed in mining or the subsequent processing of ore. Here, we only consider mining waste formed in processes regulated by the Mining Act, i.e., waste formed by the extraction or exploitation of so-called mining minerals defined in the Mining Act. Consequently, left-over rocks extracted from dimension stone quarries and rocks and soil extracted at various construction sites are not included. The Mineral Deposit database of the Geological Survey of Finland (GTK) has been constructed to facilitate the storage of data on the annual production of different types of mining waste. However, due to data shortage, the tonnages of left-over rocks extracted from each mine are the only attribute regularly recorded in the database. See also Appendix A, Section 4.3 for a brief account of waste statistics in Finland and 39 other European countries in 2010 and 2012.

Sources of data

The mining waste data is stored in GTK's Mineral Deposit database and is owned by GTK. Within the GTK intranet, the database can be accessed by using the 'METSO' interface. An external user can access the data by using the data product '**Mineral deposits**', which can be viewed and downloaded for free. Appendix A, Section 4.1 describes how to access the data in the data product (either via <https://gtkdata.gtk.fi/mdae/> or <https://hakku.gtk.fi/en/locations/search>). After opening an information box on an individual mineral deposit, a mineral deposit

report can be downloaded via a link as a pdf file. In this report, the cumulative total of mining waste is presented in the section MINING, below the heading 'Other materials' (Figure A7). Annual mining waste figures are under the heading 'Mining activity'.

GTK's Mineral Deposit database is a state-of-art database on mineral deposits in Finland. It has been designed to facilitate access to a wide range of information on mineral deposits, including mining waste. Mining waste data is needed when planning how to use this waste as a secondary raw material.

MINING

Siilinjärvi

Easting EUREF: 536941.573

Northing EUREF: 6998805.151

Status: Operating

Operating years: 1966-2020

Years in production: 47

Total ore mined: 336496863 t

Comments: Siilinjärvi mine started officially 1979. Prior to that it was in testing phase only.

References: 1, 10

Total production:

Product	Product measure
calcite	1754330 t
mica	145821 t
apatite	28654812 t

Other materials:

Material type	Material measure
waste from mineral non-metalliferous excavation	213618577 t

Mining activity:

Year	Ore mined	Ore processed	Activity type	Production	Other material
2020	10825723 t	10825723 t	open-pit mining	apatite 995066 t	waste from mineral non-metalliferous excavation 13547364 t
2019	10736327 t	10736327 t	open-pit mining	apatite 994572 t	waste from mineral non-metalliferous excavation 11272711 t
2018	10886690 t	10886690 t	open-pit mining	apatite 989073 t	waste from mineral non-metalliferous excavation 14151099 t

Figure A7. The cumulative and annual production of mining waste is available in the pdf report of each mineral deposit, under the section MINING. The data covers the type of mining waste (e.g., waste from mineral non-metalliferous excavation) and the related tonnage.

Data set properties

A sophisticated mining waste hierarchy has been designed to facilitate the storage of information on different types of mining waste in the database (Figure A8). However, due to poor data availability, only two of the categories are regularly used: 01.2 to record the extraction of left-over rocks in metallic ore mines and talc mines and class 01.1 to record the extraction of left-over rocks in industrial mineral mines (excluding talc mines). Data on the extraction of left-over rocks is directly sourced from the annual mining statistics published by the Finnish Safety and Chemicals Agency (Tukes) on its website www.tukes.fi each spring. This data is annually updated in the Mineral Deposit database (in March–April).

wastes from mineral excavation (01)
waste from mineral non-metalliferous excavation (01.1)
waste from mineral metalliferous excavation (01.2)
wastes from mineral dressing (02)
wastes from the dressing of metalliferous minerals (02.1)
cobbing waste (02.1.1)
magnetic-separation tailings (02.1.2)
wash tailings (02.1.3)
flotation tailings (02.1.4)
leach residues (02.1.5)
wastes not otherwise specified (02.1.6)
wastes from the dressing on non-metalliferous minerals (02.2)
wastes from further physical and chemical processing of metalliferous tailings (03.1)
dusty and powdery waste (03.2)
red mud from alumina production (03.3)
other sludges/muds/chemical liquid products than specified above
wastes not otherwise specified (03.5)
wastes from further physical and chemical processing on non-metalliferous tailings (04.1)
waste gravel and crushed rocks (04.1)
waste sand and clays (04.2)
dusty and powdery waste (04.3)
waste from potash and rock-salt processing (04.4)
waste from washing and cleaning of minerals (04.5)
waste from stone cutting and sawing (04.6)
waste not otherwise specified (04.7)
drilling muds and other drilling wastes (05)
oil-containing drilling muds and wastes (05.1)
barite-containing drilling muds and wastes (05.2)
chloride-containing drilling muds and wastes (05.3)
fresh-water drilling muds and wastes (05.4)
wastes not otherwise specified (05.5)

Figure A8. GTK's Mineral Deposit database contains a sophisticated hierarchy to facilitate the storage of information on different types of mining waste. However, due to poor data availability, only two of the classes are regularly filled to record the extraction of left-over rocks (classes 01.1 and 01.2).

Data access

A so-called Licence 1 (Basic licence version 1.1; 28.9.2016), see http://tupa.gtk.fi/paikkatieto/lisenssi/gtk_basic_licence_1.pdf, regulates the terms of use for mining waste data (already described in Appendix A, Section 4.1).

Technologies

Mining waste data is stored and edited in the section 'Production' in the METSO interface of GTK's Mineral Deposit database. The related technology is described in Appendix A, Section 4.1.

Future developments

Currently, there is no significant practical application for the dataset of left-over rocks extracted from mines, but development in the national mineral policy to increase the use of mining wastes could change the situation. This issue will be addressed sooner or later, and at that point, the data stored over the years will become crucial.

The database structure is being developed to facilitate the storage of even more diverse data on mining waste. However, lack of primary public data sources remains an issue. Many of the new fields will be related to the environmental impact of mining waste.

Gaps and opportunities

The data covers the annual and cumulative tonnages of left-over rocks extracted in each mine, but does not cover any event of the left-over rocks beyond extraction. Therefore, the current location and current total tonnage of left-over rocks available for use are not accurately known. In most cases, the majority of left-over rocks are probably still in the vicinity of the mine, if not fed back into the mine itself. Some of them may have been used for various construction purposes and are not available for other use. The database contains no direct information on the composition of the left-over rocks, even though some clues are provided by the description of the wall rock of the deposit.

GTK's Mineral Deposit database is built to accommodate a wide range of data on different mining waste types, but this data first needs to be made publicly available. Companies operating in Finland produce and record some mining waste data, but it is not a standard practice for them to publish this data. We suspect that much of the existing information and data are currently confidential and only held by the companies. There are major data gaps in metal contents of side streams in mines, refineries, and smelters (e.g., Eilu, et al., (2021)).

Ideally, annual production figures of many kinds of mining waste would be stored in the database; the application automatically calculates cumulative totals for each

waste type. If some production figure is a sum from several years (instead of an annual figure), this sum can also be stored in the database (just assigned to a certain year with a note that in reality it is a sum containing several years). The storage type (surface/covered/underground/underwater) as well as environmental impact of mining waste can also be recorded in the database.

4.3. Mineral statistics in the European Minerals Yearbook

Description

The European Minerals Yearbook is one of the many sources containing statistical data on minerals in Finland. In addition to Finland, nearly all other European countries are represented (about 30–40 countries, depending on the dataset). This electronic database was originally created in the Minerals4EU Project (2014–2015), funded by the EU. For primary minerals, the Yearbook contains data on production, import and export, resources and reserves, and exploration. For secondary raw materials, some waste flow data is included. Following the end of the Minerals4EU Project, the Yearbook has been updated to contain production and trade data for all years between 2004 and 2018.

EGDI portal at https://data.geus.dk/egdi/?mapname=egdi_geoera_mintell4eu additionally contains data for the statistical year 2019 (production, resources and reserves, and exploration) and is more sophisticated as a user interface. Data for 2019 was collected in the MINTELL4EU Project (2018–2021), funded by the EU. This is the first major attempt to compile as comprehensive as possible national data on primary resources and reserves of several European countries by using one, harmonised reporting code, the UNFC classification (UNECE, 2020). Using a harmonised reporting code is a prerequisite to summing the resources and reserves from the deposit level to the national level. Only in this way can one arrive at a truly meaningful answer to a question such as how much cobalt there is, for example, in the mineral resources of Finland. If the coverage of new data is sufficient, this could allow, for the first time, the compilation of pan-European resources and reserves of different commodities (see the sub-section Future developments).

Sources of data

The European Minerals Yearbook can be found at <http://minerals4eu.brgm-rec.fr/m4eu-yearbook/index.html>. The purpose of the Yearbook is to contain official and best possible mineral statistics of European countries. The Yearbook will be regularly updated. Mineral statistics data is highly valuable for a great number of different purposes and is essential, for example, in supporting political decision making related to the utilization of natural resources and in supporting investment decisions.

Data set properties

A detailed user guide of the European Minerals Yearbook can be downloaded at <http://minerals4eu.brgm-rec.fr/node/45527>. The text below summarises some of the main points. Based on the selection made on the landing page of the Yearbook, the data can be viewed by country (Figure A9) or by commodity (Figure A10).

EUROPEAN MINERALS YEARBOOK - DATA FOR Finland

Production Import Export Resource Reserve Exploration Waste flow

Show 10 entries Search:

Commodity	Sub-commodity	Units	2004	2005	2006
Aggregates and related materials	Crushed rock	t	Estimate 43000000	Estimate 45000000	Estimate 49000000
Chromium ores and concentrates (gross weight)		t	580000	372000	549000
Cobalt (mine production, metal content)	Ores and concentrates (metal content)	t(mc)		Estimate 100	Estimate 100
Cobalt (refined)	Refined	t	7893	8171	8582
Copper (mine production, metal content)	Ores and concentrates (metal content)	t(mc)	15500	15000	13000
Copper, refined		t	132384	132126	137961
Copper, smelter		t	151647	157933	164306
Crude steel		t	4832427	4738446	5053714
Feldspar		t	44495	42783	43187
Finished cement		t	Sales 1290000	Sales 1347000	Sales 1684507

Figure A9. Data by country is displayed in table form. The data type can be selected from the seven tabs (from Production to Waste flow) above the table. The view can be scrolled to the right to proceed towards more recent years.

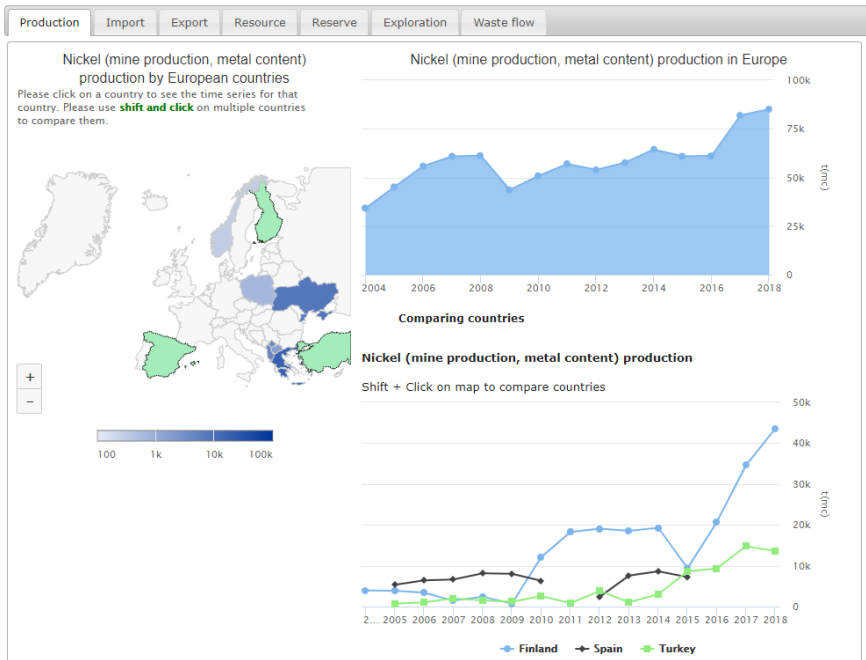

Figure A10. The 'Data by commodity' view shows total figures for Europe in the blue chart in the upper right corner. The chart below this presents figures for those countries selected on the map. The data type can be selected from the seven tabs at the top.

The European Minerals Yearbook contains production data for 40 countries during 2004–2018, and for over 65 primary mineral and metal commodities. For Finland, data on 27 commodities is included. The data is collected by the British Geological Survey (BGS) using long-established BGS procedures with an international network of contacts from data providers. The data is collected in three main ways: by writing directly to the data source, often using a questionnaire, by receiving printed or digital publications, and by consulting websites or web-based databases.

Import and export data for primary minerals covers 35 countries during 2004–2018 and over 65 commodities (and many more sub-commodities). For Finland, import and export data on 57 commodities or sub-commodities is included. The trade data is purchased in bulk from an agency that specialises in monitoring trade information. The data is then compared with the United Nations (UN) commodity trade web database, Eurostat's online database, or, in some cases, with databases compiled by national statistical offices.

Resource and reserve data and exploration data for primary minerals cover about 30 countries and over 65 commodities. These data are only available from countries that returned the questionnaires during the Minerals4EU project AND where data in

these countries was available. Resources and reserves data depicts the situation as of 31.12.2013, while exploration data depicts the year 2013.

For Finland, resource data includes 27 commodities and reserve data includes 14 commodities. The data for 2013 is presented at the deposit level, i.e., the data has not been aggregated to the national level. There are two reasons for this: 1) companies had used many different reporting codes while carrying out the original reporting of resources and reserves and 2) ideas for a uniform reporting code and related conversion methods had not been widely adopted by the geological community in 2015, but only during later years. Considerable progress in this issue is taking place and described under Future developments. Exploration data for 2013 in Finland only contains written notes, but the update for 2019 will also contain numerical data, described under Future developments.

Waste flow data covers 33 countries for 2010 and 2012. This data is only available by category, not by commodity. The categories included in the Yearbook are batteries and accumulators, combustion wastes, discarded equipment, discarded vehicles, dredging spoils, glass waste, ferrous metal wastes, non-ferrous metal wastes, mixed metal wastes, mineral waste from construction and demolition, mineral wastes from waste treatment, and other mineral wastes. Of these, the following data are presented: waste generated (tonnes), waste imported (tonnes), waste exported (tonnes), and waste treated (tonnes). Data on waste treated has been divided into six treatment options displayed in green characters. In addition, there is data on waste facilities in 2010 and 2012. Waste data was collated from public sources, including the Eurostat waste statistics database, the Eurostat Comext database, and other national databases and publications (from National Environment Agencies, Ministries of the Environment, etc.).

Data access

The data is public and can be accessed free of charge.

Technologies

A sophisticated online platform was created in the Mintell4EU Project for national data providers to submit data on production, resources and reserves, and exploration of primary mineral raw materials. This platform was used for the first time when collecting data for the year 2019 in the Minetell4EU minerals survey during early 2021. The data goes through the quality control of the British Geological Survey before being published in the European Minerals Yearbook or in the EGDI portal.

Future developments

Data for the statistical year 2019 (production, resources and reserves, and exploration) has only recently been updated in the EGDI portal at

https://data.geus.dk/egdi/?mapname=egdi_geoera_mintell4eu. This is a state-of-art web portal used to distribute different geological datasets, and it might possibly replace the European Minerals Yearbook in the future. The data for 2019 was collected in an online Mintell4EU minerals survey. National geological surveys were requested to provide data on resources and reserves (situation at a single point in time: 31.12.2019) for their own country, as well as exploration data for 2019. Production data can also be submitted in this platform, but no trade data, which will be bought from a specialized agency. Resource and reserve data on any reporting code was accepted, because in this way, the picture will be as complete as possible. In addition, all data reported in any of the codes belonging to the CRIRSCO family can be easily converted into UNFC (CRIRSCO, 2013; UNECE, 2015). All data on resources and reserves in Finland was submitted in the UNFC reporting code.

Exploration data for 2019 in the EGDl portal includes the following five variables: 1) number of active licences, 2) number of issued licences, 3) total licenced area, 4) number of companies exploring, and 5) expenditure (investment in exploration in €). The data is collected per commodity for a statistical year. During the Mintell4EU minerals survey, data on 32 commodities for the four first-mentioned variables was submitted for Finland. Commodity-specific expenditure is not available for any of the commodities. The exploration data was compiled from the Mining Register of Finland, maintained by the Finnish Safety and Chemicals Agency (Tukes). This is presumably the first time this type of commodity specified national compilation had been carried out by using the data in the Finnish Mining Register.

Three issues to note regarding the 2019 exploration data of Finland in the EGDl portal are as follows:

- The data only covers exploration in valid exploration permit and valid claim areas. Therefore, brownfield exploration (exploration carried out within mining permit areas or mining concession areas) is excluded in the statistics.
- For most exploration permit or claim areas, several commodities (up to 10 for some areas) are listed as target minerals in the Mining Register. In reality, companies focus more on some of the listed commodities than others. Therefore, some of the commodities appear overrepresented in the data.
- Numbers for different commodities within any of the variables cannot be summed to obtain a national total of the variable in question. National totals are published by Tukes on its website each spring.

Gaps and opportunities

Major challenges identified in the data and information on resources and reserves include the following:

- Data gaps. Accessibility of national resource data differs among European countries. How can the completeness of the reported national resources be assessed?
- Variable resource reporting standards between deposits and countries. For one deposit, there may be high-quality quantitative mineral resource and reserve data, whereas for another deposit, the estimate may only be based on scarce data. In addition, the reported resource practically never covers the entire mineral deposit, as the cost of exploring a deposit is prohibitive.
- Lack of up-to-date resources data: resources may have been estimated several years or even decades ago.
- Lack of access to resource data on industrial mineral deposits held or mined by non-listed companies. This is a common issue across the world, and especially relates to talc, wollastonite, quartz sand, and carbonate (calcite, dolomite, magnesite) deposits. These companies usually do not report their mineral resources, even to national authorities, unless required to do so by the law.
- Inadequate quality data. Documentation of resource estimates does not always ensure a transparent view of the resources. In such cases, the reader cannot clearly understand the basis of the resource estimates and their classification.
- CRM data is dominantly of low quality. This is because most CRMs are (potential) by-products of a mine, often seen to mean little if any added value for the economy of a mine (e.g., the Rare Earth Elements). Also, some of the CRMs (e.g., antimony and bismuth) have, for a long time, been regarded as harmful substances, decreasing the value of the ore. This means that a mining company may have concentration data on a metal but does not report it in public, to avoid possible negative effects on the share price of the company.
- Very little quantitative information exists on potential secondary mineral and metal resources: For the overwhelming majority of cases, in all European countries, there is only location information and circumstantial indications of what potentially extractable commodities might occur at a site. For the CRMs, even the circumstantial information is predominantly missing. This holds for mining, refinery, and smelter side streams and wastes.

All these issues naturally also indicate opportunities for improvement. A major push in making the existing mineral resource data comparable between deposits and countries is underway by the UNECE and by the MINTELL4EU project (Hokka & Eilu, 2021), in which work has been done to introduce the UNFC reporting system. Other nationally funded and EU-funded projects have been and are producing and improving the CRM and secondary resources data, making them also available through EU resource information and data platforms.

4.4. Mineral exploration activity and results

Description

In Finland, exploration of the so-called *mining minerals* is regulated by the Mining Act and licenced by the national mining authority. Since 2011, this authority has been the Finnish Safety and Chemicals Agency (Tukes). Tukes is responsible for licencing mineral exploration and maintaining data on exploration activities and results that exploration companies must report to Tukes. Tukes maintains GIS data that shows the current status of areas that are in some way 'active' in relation to permitting for exploration or mining (e.g., application submitted, valid permit, expired permit in quarantine). This publicly available GIS data contains the boundaries and general information on these areas and is referred to as the Mining Register in this report. Exploration is allowed in areas with a valid claim (previous Mining Act) or exploration permit (current Mining Act).

Once a claim or an exploration permit has expired and a subsequent quarantine period is over, the area is deleted from the Mining Register and added to the data product 'Expired claim and exploration permits' maintained by the Geological Survey of Finland (GTK). Exploration results and the related data become public after a certain period and are linked to this data product. Some exploration results typically already become public during the exploration work, as many companies are eager to publish their findings.

Data on present and past exploration activity describe the efforts to locate new mineral deposits and increase information on the known deposits. This data does not cover mineral production or describe what enters the circular loop, and the connection to the circular economy is therefore very thin. The Mining Register also contains mining permit and mining concession areas, but these only show where the exploitation of mining minerals is allowed (they do not show whether any mineral production is actually taking place).

Sources of data

Data in the Mining Register is maintained and owned by Tukes. Tukes provides the most recent version of the GIS files for download in its website at <https://tukes.fi/en/mining-ore-prospecting-and-gold-panning/map-files>. Tukes also provides this data in an interface from which it is harvested for several online map services, including:

- 'Kaivosrekisterin karttapalvelu' maintained by GTK at <https://gtkdata.gtk.fi/kaivosrekisteri/> (Finnish language only)
- 'Mineral Deposits and Exploration' maintained by GTK at <https://gtkdata.gtk.fi/mdae/> (path Exploration layers / Mining Registry) (Figure A11) (English language only)

- 'Paikkatietokkuna' at <https://kartta.paikkatietokkuna.fi/> maintained by the National Land Survey of Finland (MML) (Figure A12).

The purpose of the data is to facilitate the legal obligation of Tukes to administer licencing of exploration and mining activities and provide public information on the present status of licencing in different areas. All areas displayed in the Mining Register are currently reserved for on-going or future exploration or mining and are not available for other companies.

The data product 'Expired claim and exploration permits' is publicly available in two locations and can be

- viewed in the online map service 'Mineral Deposits and Exploration' maintained by GTK at <https://gtkdata.gtk.fi/mdae/> (path Exploration layers / Mining Registry / Expired claims) (Figure A11) (English language only)
- downloaded via the Hakku web service maintained by GTK at <https://hakku.gtk.fi/en/locations/search> and viewed in GIS software.

The data on past exploration activity shows where exploration has already been carried out and what the main mineral discoveries were (if any). Other exploration companies can utilize the data when planning exploration campaigns: they can build on knowledge gained from previous work and avoid duplicating expensive work that has already been carried out. The data can also be utilized in geological research.

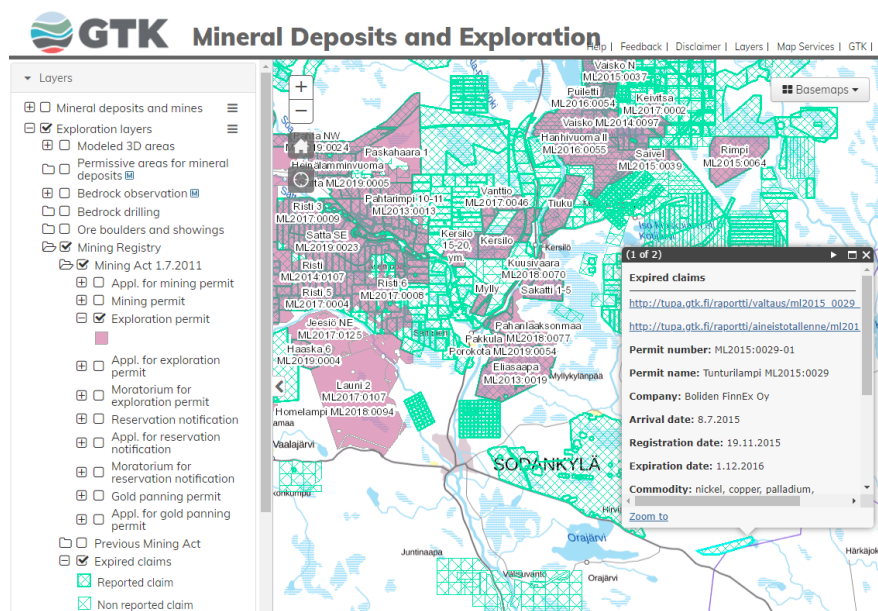

Figure A11. Valid exploration permits (red) and expired claims and exploration permits (green) in the Sodankylä region in GTK's public online map service 'Mineral Deposits and Exploration' at <https://gtkdata.gtk.fi/mdae/>. The information box of the

expired Tunturilampi exploration permit contains links to the exploration report and other data on exploration results, and also presents general information on the area.

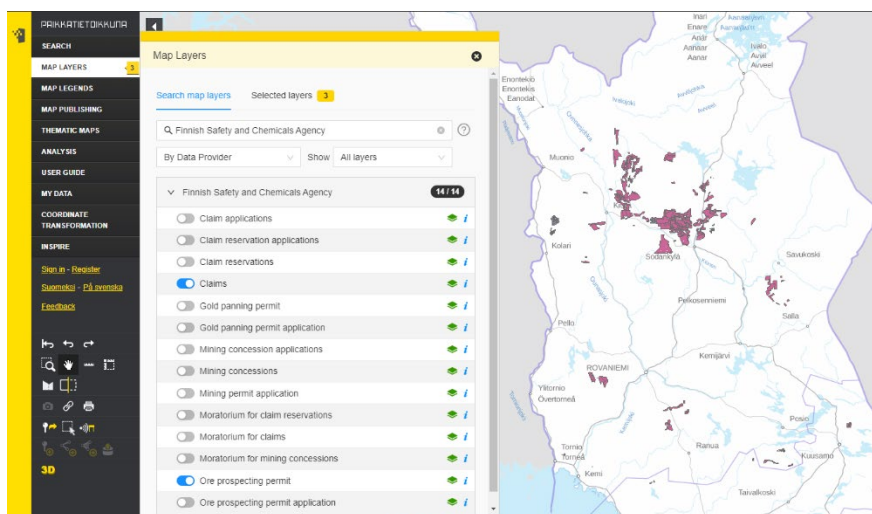

Figure A12. Different layers of the Mining Register are available in the public online map service Paikkatietoikkuna maintained by the National Land Survey of Finland at <https://kartta.paikkatietoikkuna.fi/>. These layers can be located by entering “Finnish Safety and Chemicals Agency” into the search window when using a search by data provider.

Data set properties

The Mining Register covers the whole of Finland. A user can check whether a certain area is in some way ‘active’ in relation to permitting for exploration or mining. Timewise, the Mining Register is kept updated to show the present situation. It separately shows areas under the current Mining Act (621/2011) and the previous Mining Act. The current Mining Act is represented by ten different layers: eight related to industrial-scale mineral exploration or artisanal gold panning and two related to mining. Exploration is allowed in areas with a valid exploration permit. The previous Mining Act is represented by six different layers: three related to exploration and three related to mining. As of January 2022, the Mining Register contains 280 areas with a valid exploration permit and 167 areas with a valid claim (however, even though ‘valid’, the expiration date for all 167 claims has already passed; the last one expired in December 2019).

The attributes for each exploration permit and claim area are the permit code, permit name, name of permit holder, arrival date of the application, registration date (= date of decision), expiration date, and the commodities explored. This information is sourced from applications submitted by exploration companies and from the decision documents of Tukes. The data is updated continuously, and updated data

are published every two or three weeks. The mentioned online map services maintained by GTK or MLL present the Mining Register data as provided by Tukes.

Once an exploration permit expires, the permit holder must within six months submit a final report on exploration activities to Tukes, as well as the exploration data. Once the quarantine period expires, the area is deleted from the Mining Register and added to the data product 'Expired claim and exploration permits'. The report on exploration work and exploration data are delivered by Tukes to GTK and linked in the data product (Figure A11.); other attributes presented are essentially the same as in the Mining Registry. The reported and non-reported areas are displayed with different symbology. Data has also been sourced from previous mining authorities: the Ministry of Trade and Industry (KTM), followed by the Ministry of Employment and the Economy (TEM).

The dataset 'Expired claim and exploration permits' was produced between 2000–2016 by scanning exploration work reports and digitizing expired claim areas as polygons in GIS files. Additional metadata on 'Expired claim and exploration permits' are available at https://tupa.gtk.fi/paikkatieto/meta/expired_exploration_permits.html.

Data access

The GIS data of the Mining Register is publicly available to be downloaded free of charge. Tukes presents the conditions for using the data at <https://tukes.fi/karttatiedostot-rss-atomfeedina>. There, Tukes disclaims all responsibility for any consequences caused as a result of the use of the material. As no other condition is listed, it is implied that this is open data and can be used in any way, including commercial applications and services.

A so-called Licence 1 (Basic licence version 1.1; 28.9.2016, see http://tupa.gtk.fi/paikkatieto/lisenssi/gtk_basic_licence_1.pdf) regulates the terms of use for the data of 'Expired claim and exploration permits'. The data is publicly available to be downloaded free of charge. However, without the advance permission of GTK, the data can only be used for certain personal purposes or for internal use within an organization (documents created for authorities, scientific publications, and teaching materials being exceptions).

Technologies

Tukes reports using MapInfo software to digitize the borders of the areas subject to a new application for an exploration permit. By using a georeferenced GIS database, Tukes can easily check whether an area in an application overlaps areas that are in the Mining Register with a status that prevents the granting of a new permit.

Tukes provides Mining Register files for distribution as downloadable ZIP files and an ATOM feed at <https://tukes.fi/karttatiedostot-rss-atomfeedina>. The ZIP files contain the GIS files in TAB, MIF, and SHP formats, which allows viewing with GIS

software, such as QGIS, open-source OpenJUMP, or commercial MapInfo or ArcView.

An ATOM feed is an interface allowing other organisations to use the data. For example, at GTK, an FME Desktop workspace reads the ATOM feed provided by Tukes and converts it into ESRI's Geodatabase format, which is used in GTK's distribution channels.

The database of expired claim and exploration permits was compiled by digitizing the borders of the oldest areas from claim reports. Claim areas granted after 1995 or thereabouts, as well as exploration permit areas under the current Mining Act, have been picked from the map files of the Mining Register. The old exploration work reports were scanned, and they are currently delivered in electronic format by Tukes.

Future developments

The Mining Register facilitates the legal obligation of Tukes to administer licencing of exploration and mining activities. Without this public register, it would be complicated to fulfil this obligation and complicated for exploration companies to know which areas have already been reserved by other companies. All this indicates that the Mining Register is an extremely important web service and heavily used.

The expired claim and exploration permit database is updated monthly and is actively used by mining companies and for research purposes.

Gaps and opportunities

Not all exploration work has been properly reported. Location inaccuracies in the digitised material should be considered when using the data. Information on possible by-products of a deposit is typically scarce.

Regarding opportunities, there is no need for specific software documentation or specific software to be downloaded with the data, as the data can be accessed with standard tools.

4.5. Undiscovered mineral resources

Description

Geological Survey of Finland (GTK) has carried out assessments of undiscovered mineral deposits in Finland since 2008. These deposits contain resources that are believed to exist at 0–1000 m depth in the bedrock, even though they have not been discovered yet or are only partly known to exist. The assessment only covers those undiscovered deposits that are believed to be economically exploitable.

The data on undiscovered mineral resources in Finland can be accessed in the data product called '**Permissive areas for mineral deposits**'. Within the permissive areas, geology permits certain types of mineral deposits to exist. So far,

the assessment has been carried out for 14 different deposit types (Rasilainen K. et al., 2017; Rasilainen K. et al., 2018; Rasilainen K. et al., 2020). In the dataset, each deposit type is presented on a separate layer that contains several polygons representing individual permissive areas. Each polygon is associated with attributes such as the number of undiscovered mineral deposits and the estimated content of different metals in metric tons – these estimations are reported at several different probability levels.

Sources of data

The data on undiscovered mineral resources is owned by GTK. The data can be 1) viewed in GTK's web service 'Mineral Deposits and Exploration' by using a web browser or 2) downloaded and viewed by using GIS software.

- 1) As a user, enter GTK's webservice 'Mineral Deposits and Exploration' at <https://gtkdata.gtk.fi/mdae/>. There, the layers of the 14 different mineral deposit types included in the assessment can be found by following the path Exploration layers / Permissive areas for mineral deposits (Figure A13.). Check the check boxes in order to see the permissive areas on the map.

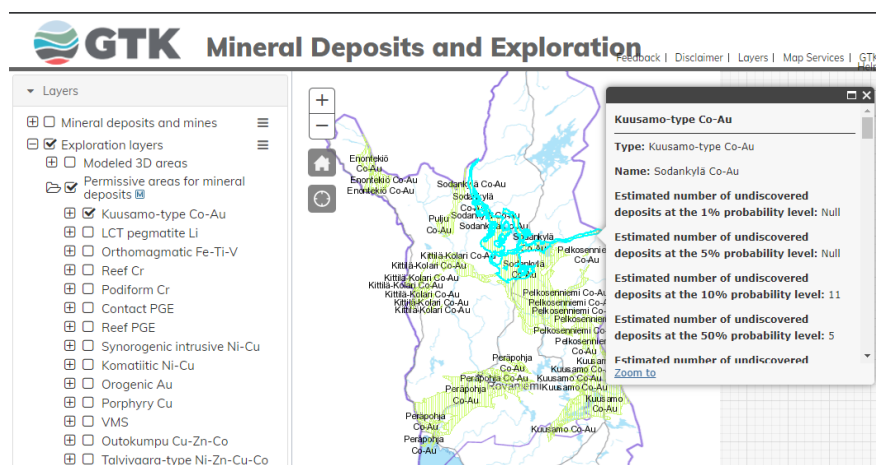

Figure A13. GTK's public web service 'Mineral Deposits and Exploration' at <https://gtkdata.gtk.fi/mdae/> contains a separate layer for each of the 14 mineral deposit types included in the assessment of undiscovered mineral deposits. Permissive areas of Kuusamo type Co–Au deposits in northern Finland are displayed in this image. The information box shows the attributes of a permissive area named 'Sodankylä Co-Au', and its borders are highlighted in light blue.

- 2) As a user, enter GTK's web service Haku at <https://hakku.gtk.fi/en/locations/search>. To locate the product, scroll down the product list or write "Permissive" in the search field (Figure A14).

Spatial data products

permissive

Free of charge
GTKs open license

Showing 1 spatial data product(s)

Permissive areas for mineral deposits

Permissive tracts are areas where geology permits certain types of mineral deposits to exist. Each deposit type has a layer that consists of several separate geographic areas. Each permissive tract contains information on the number of possibly existing mineral deposits and their metal contents in metric tons, estimated at several levels of probability.

File formats and coordinates
esi_file_gdb epsg_3067

Interface
Price 0 € (VAT 0%)
Download
Price 0 € (VAT 0%)

Metadata

Basic license Last update: 11.07.2019
Other distribution channels: Mineral deposits and exploration

Map view Offer requests (0)

Figure A14. The data product 'Permissive areas for mineral deposits' can be downloaded from GTK's web service Haku at <https://haku.gtk.fi/en/locations/search>.

Information on undiscovered mineral resources is important for several purposes. Exploration and mining companies require such information to support investment decisions. Political decision makers and administrative organisations need this information to support decisions concerning land use planning. Research institutions can use the information to widen and deepen the knowledge of raw material deposits and to be able to deliver advice to society, industry, as well as administrative and political entities.

Data set properties

At <https://gtkdata.gtk.fi/mdae>, data on each of the 14 mineral deposit types are on different layer; in data downloadable at <https://haku.gtk.fi>, each of the 14 mineral deposit types are included within the same layer as different feature classes. Attributes associated with each permissive area can be opened for viewing by clicking on the polygon, and these include:

- Mineral deposit type
- Name of the individual permissive area
- Estimated number of undiscovered deposits at five probability levels (1%, 5%, 10%, 50%, 90%). An example: a certain permissive area is estimated to contain at least 8 undiscovered deposits with 10% probability and at least 1 undiscovered deposit with 90% probability.
- Expected (mean) number of undiscovered deposits. An example: the estimations of five different experts are that the number of undiscovered deposits in a certain permissive area is 2, 4, 4, 5, 13. The mean is 6 ($= \frac{2+4+4+5+13}{5}$).

- Estimated undiscovered resources (in metal tonnes) of silver, gold, cobalt, chromium, copper, iron, lithium, molybdenum, nickel, lead, palladium, platinum, titanium, vanadium, and zinc. For each metal, estimation is given with 10% and 90% probability levels, and a median estimate and mean estimate are also given.

Undiscovered mineral resources have been assessed within the national borders of Finland. The assessment also extends to areas covered by water, i.e., bedrock under lakes, the Gulf of Finland, and Bothnian Bay. The data reflects the situation and knowledge at the time the assessment was carried out.

The data can be downloaded as the spatial data product '**Permissive areas for mineral deposits**' through GTK's Hakku web service. The data are in geodatabase format. In this service, click the + sign on the left side of the product title to reveal the content below the product title (Figure A14). Click 'Download' to transfer the item into the shopping cart (the price will be 0 €). Open the shopping cart, click 'Proceed to order', and fill in the required customer info. Then, click 'Order preview'. You are required to accept the terms of use, the purchase and delivery terms, as well as the collection of personal data needed for handling the data deliverance. Finally, you will receive an automatic email with a download link to download the data as a zip file "permissive_areas_for_mineral_deposits_epsg3076_gdb.zip". The size of the zip file is 3.54 MB.

Among the 14 mineral deposit types, a total of 253 permissive areas have been defined as polygons. The sum of the area of all polygons is 320 466 km². It should be noted that permissive areas for different mineral deposits commonly overlap, resulting in multiple counting.

The data product is updated each time the assessment of a new mineral deposit type has been completed. So far, no revision of assessments carried out earlier has been made to better reflect the increased knowledge and general situation. As the assessment focuses on undiscovered deposits that could be economically mined, which to a certain extent is dependent on metal prices and available technologies, revision in long-term cycles (e.g., 10–20 years) is worth considering.

Data access

A so-called Licence 1 (Basic licence version 1.1; 28.9.2016, see http://tupa.gtk.fi/paikkatieto/lisenssi/gtk_basic_licence_1.pdf) regulates the terms of use for the data. The data is publicly available to be downloaded free of charge. However, without the advance permission of GTK, the data can only be used for certain personal purposes or for internal use within an organization (documents created for authorities, scientific publications, and teaching materials being exceptions). A summary of the License 1 is presented in Appendix A, Section 4.1.

Technologies

The data is a synthesis of all available knowledge on the geology in Finland, global grade-tonnage data on the mineral deposit type in question, as well as the subjective opinions of the experts participating in the assessment. The Delphi technique (Rowe & Wright, 1999) is used in assessing the number of undiscovered mineral deposits per permissive area. For each deposit type, the Finnish data and recent international data have been used to test the applicability of the global grade-and-tonnage models. This has resulted in both updating of the global models and, in some cases, the creation of new models better suited to the geology of Finnish mineral deposits.

In Finland, the assessments have been carried out by using the basic office software and ArcGIS. However, in the MAP project (2018–2020) funded by EIT RawMaterials, a free software package called MapWizard was developed to streamline the assessment procedure. This software, downloadable at <https://github.com/gtkfi/MapWizard/releases>, can be used in regional or local assessments in new projects or consulting work.

The data is maintained as geodatabase files. ArcGIS and other commercial or free spatial data software can be used to further edit the dataset. The data is distributed as a zip file that can be downloaded for free from GTK's Hakku web service. The data can also be viewed in GTK's web service Mineral Deposits and Exploration by using a web browser.

Future developments

Assessment of undiscovered phosphorus and Rare Earth Element (REE) deposits in peralkaline rocks, carbonatites, and Th–REE-rich dykes is currently on-going in December 2021. Once this is completed during 2022, the dataset will be updated. After that, all significant deposit types in Finland will have been assessed for undiscovered mineral resources.

At the moment, there is a major push across Europe to report all mineral resources by using the UNFC resource classification. In this classification, undiscovered mineral resources can be categorised into the class 3,4,4. This offers new possibilities for the dissemination of undiscovered mineral resources and will help in increasing its visibility.

For many mineral deposit types, the undiscovered resources have not yet been assessed for all those critical raw materials (CRM) that are known to occur in Finland.

Gaps and opportunities

The subject of this dataset is hypothetical in nature. There is no guarantee that any of the estimated undiscovered resources will ever be found or utilised. The recent discovery of a major gold deposit in Sodankylä (Rupert Resources, 2021) is,

however, an indication that 'undiscovered' resources may indeed turn into 'discovered'.

The data does not indicate the exact locations of the undiscovered mineral deposits, but 1) areas where geology permits these deposits to occur, 2) the estimated number of undiscovered mineral deposits within each area, and 3) the estimated tonnages of different metals in these deposits.

Use of the data is quite strictly controlled by the user licence: without prior written permission from GTK, other organisations are not allowed to republish the data externally (apart from use by authorities, in scientific publications, and in teaching materials).

The main data gaps in the assessment of undiscovered mineral resources are:

- Only those deposit types can be assessed for which there is enough grade and tonnage data to make a statistically reliable numerical model. A prime example is that it has not been possible to carry out assessments for Talvivaara-type nickel–zinc–copper–cobalt deposits and Kevitsa-type nickel–copper–cobalt–platinum–palladium deposits.
- The lack of data also has prevented assessment of the metal endowment of most of the CRMs, as they are predominantly just possible by-products of mining and, hence, rarely included in published mineral resources. Examples of such metals include antimony, beryllium, bismuth, gallium, germanium, indium, niobium, tantalum, and tungsten.

Obtaining more deposit-scale information on all types of mineral deposits and on the potential by-products is the way to improve the quality and extent of the assessment of undiscovered mineral resources. All this information would also positively affect how a mineral resource is mined and what is extracted from the ore.

Regarding data possibilities, all results of the national assessments of undiscovered mineral resources carried out by GTK are public. Supporting information on each assessment is published in GTK's publication series 'Report of Investigation', also available via the Hakku webservice at <https://hakku.gtk.fi/>.

4.6. Mineral exports and imports

Description

Finnish Customs provides data on the foreign trade of Finland in its statistical online database called Uljas. A huge amount of data is available in this complex database utilizing several classification systems, for example the Combined Nomenclature (CN) of the European Community and the Standard International Trade Classification (SITC) of the United Nations. Here, we describe the foreign trade of mineral raw materials in the CN classification. This is divided in 21 Sections (I–XXI) that contain in total 99 Chapters (see <https://tulli.fi/en/statistics/combined-nomenclature-cn>). Mineral products form Section V, which contains Chapters

25–27. See also Appendix A, Section 4.3 for another source of data on mineral exports and imports of Finland (as well as other European countries).

Sources of data

Data on the foreign trade of Finland is freely available in the electronic ‘Uljas’ database at <https://uljas.tulli.fi/>. This is the official information source regarding imports, exports, and the balance of trade of Finland. The database is owned and maintained by Finnish Customs. These statistics provide a reliable picture of the latest development of international trade. They constitute an important instrument for decision makers, as well as planners and researchers in the public and private sectors, both at the national level and within the operations of the EU and several international organisations.

Data set properties

Information in the CN classification exists since 1995. There are slight changes in the nomenclature each year, which means that it is not possible to form a coherent time series for all commodities. In practical terms, data collected from 2002 onwards is more unified with the current data.

In the Uljas database, a user first needs to select between two options: ‘CN from 2002→’, containing data from 2002 onwards, and ‘CN/HS 1989–2002’, containing older data. Further selections defining the data of interest are the subcategory of CN classification, trade items within this subcategory, the time period, countries, direction of foreign trade (export/import), and finally the indicator of interest. Once completed, the application instantly retrieves the queried data from the database. In this way, a user can find out, for example, what the value (in euros) of copper ores and concentrates imported to Finland from all countries together was in 2018. The functionalities for different selections are briefly explained in the following.

The CN classification contains hierarchical subcategories CN2, CN4, CN6, and CN8. Of these, CN2 is the most general and CN8 is the most detailed and, thus, often also the most useful. While CN2 is divided into 99 items (the 99 Chapters mentioned above), CN4 is divided into 1264 items, CN6 into 6186 items, and CN8 into 14 604 items. Items in CN2 are coded with two figures, and items in CN8 with 8 figures.

As mentioned above, in CN2, mineral products can be divided into three groups (or Chapters):

- 25: SALT; SULPHUR; EARTHS AND STONE; PLASTERING MATERIALS, LIME AND CEMENT
- 26: ORES, SLAG AND ASH
- 27: MINERAL FUELS, MINERAL OILS AND PRODUCTS OF THEIR DISTILLATION; BITUMINOUS SUBSTANCES; MINERAL WAXES

In CN2, ores are placed in Chapter 26. In CN8, there are 30 different types of ores, for example the following:

- 26030000: Copper ores and concentrates
- 26040000: Nickel ores and concentrates
- 26080000: Zinc ores and concentrates

The most important trade items related to metallic ores and non-energy industrial minerals are listed in the Appendix 1 of the Sector report of the mining industry 2021 (Ministry of Economic Affairs and Employment of Finland, 2021, pp. 75-78).

A user can select one or more countries for the source of imports or destination of exports. The selection 'All countries together' is also very useful. In addition, a wide range of country hierarchies can be used (e.g., Europe, EU-27, North America, developing countries).

Concerning the direction of flow, a user should select between imports or exports (or select both). The country of origin is the country in which the goods were produced or the latest economically important production stage took place. The packaging of the commodities is not regarded as production. In practical terms, there seems to be no difference between 'Imports by countries of origin' and 'Imports by countries of consignment'. As for export, the country of destination is the last country known at the time of the export from Finland, either direct or via another country.

Finally, a user should select one or more indicators. Two very useful indicators for basic use are 1) cumulative value in euros from the beginning of the year and 2) cumulative quantity (= cumulative quantity in kilograms from the beginning of the year).

Information on the trade carried on by Finland with the other EU Member States is collected from the compulsory statistical declarations provided monthly by importers and exporters through the Intrastat system of internal trade. The information on the trade between Finland and Third Countries is obtained from customs declarations, which have to be submitted for every import and export consignment. The data on both internal and external trade is put together to form the statistics on the international trade of Finland.

The monthly statistics are published within 9 weeks after the end of the respective month. The timetable for publishing is available at <https://tulli.fi/en/statistics/publishing-timetable>. At first, the published figures are preliminary and contain estimates. They are supplemented by estimations on missing statistics declarations and those on companies with figures remaining below the threshold values. The statistics for each calendar year are confirmed by the end of August in the following year.

The country codes comply with those of the ISO/DIS 3166 standard of the International Organization for Standardization.

Data access

Data in the Uljas database can be freely used in every feasible way (also commercially) provided that the source is mentioned. The Creative Commons Attribution 4.0 International licence is applied to Finnish Customs statistical data published in the Uljas database. This is a licence according to the JHS 189 recommendation for open data files in public administration.

Technologies

Uljas is a web-based database that is used with a web browser. A user needs to make a range of selections defining the variables for the data of interest. Once completed, the application instantly retrieves the queried data from the database. The data can be exported into an Excel file. A user can produce different graphs from the data in a web browser or in the exported Excel file. Since calculation tools are very modest in the web application, Excel is definitely recommended for making any calculations with the data.

Gaps and opportunities

Enterprises have the possibility to suppress data relating to trade in cases where enterprise-specific data is recognisable in publications and this would harm its business. Normally, this refers to a case where one statistical class contains fewer than three enterprises or the enterprise that presented the request represents at least 75% of the total value of the statistical class. Finnish Customs suppresses statistical data only at the request of an enterprise engaged in trade. In practice, the result of the suppression may be that quantity data (in kilograms) revealing the country of origin or destination is not published or quantity data is not published at all. However, the data on the total value (in euros) of the so-called suppressed commodity subheadings is always published. Suppressed data are marked with three dots (...).

5. Surveys on industrial production and material utilization

Mika Naumanen

5.1. Industrial production materials and supplies

Description

In a working circular economy, the demand for natural resources as raw materials decreases as they are replaced with recycled materials. Good planning can also improve the efficiency of production processes and extend the service life of products, and these measures are also reflected in a decreasing use of virgin raw materials. Currently, few statistical classifications distinguish the use of raw materials by source, but natural resources taken into use in the economy can be measured with domestic material use.

The industrial production materials and supplies survey material contains purchasing information on the materials and supplies used in the manufacture of goods in industrial production. Purchasing information is requested from informants on an item-by-item basis. Purchased materials and supplies refer to raw materials, semi-finished products, additional materials, and supplies purchased from outside the enterprise for production during the calendar year, for the manufacture of goods in industrial production, regardless of the year of use.

Sources of data

The industrial production materials and supplies survey covers the main industries of the Industrial Classification (TOL) 2008 "B Mining and quarrying" and "C Industry". As a general rule, all companies with at least 20 employees (legal units) with sites (establishments) in the industrial sector (B or C) are included in the inquiry. The reporting units are enterprises or their establishments. An establishment refers to an economic unit owned or controlled by an enterprise that produces goods and services of mainly one particular type usually at one location. The inquiry also covers subcontractors who carry out contract manufacturing on behalf of another company.

Instructions on the filling in of material and supply data requests the reporting of at least 80% of purchases and 100% of total use for the titles in which total use is required. Thus, at least the most important materials and supplies used in production during the calendar year are collected from the units supplying the data.

Data set properties

Since the statistical year 2013, data have been collected only for uneven statistical reference years, i.e., every other year. Prior to that, data were collected annually. The change in Statistics Finland's business statistics system slightly weakened the comparability of data before and after the statistical year 2013.

In the statistical year 2019, a nomenclature change was made. The nomenclature was changed from Statistics Finland's own classification to the CN classification (Combined Nomenclature). As an example, the EUBIONET III project proposed a comprehensive and detailed list of present and potential new raw materials for bioenergy. The classification was based on the identified materials but also created a proposal for a Combined Nomenclature that divides the raw materials into connected groups (Alakangas, Nikolaisen, Sikkema, & Junginger, 2011). The joint work with Eurostat in developing a wood pellet CN (combined nomenclature) code (4401 30 20) has been finalised and the first European trade statistics have been published since 2009. From 2012 onwards, there has also been a corresponding HS (harmonised system) code for global use. This means that trade flows of solid biofuels can be monitored with reasonable accuracy using official statistics (Alakangas, et al., 2012).

Prior to the statistical year 2019, the nomenclature of materials and supplies was based on the classification developed by Statistics Finland on the basis of the European Community's CPA 2008 industry classification of products, applied to meet national needs. The length of the code is 6–7 digits. The first four digits of the code correspond to the code of the Statistical Classification of Economic Activities in the European Community (NACE Rev. 2) and thus to the first four digits of Statistics Finland's classification of economic activities, TOL 2008.

The variables of the industrial production materials and supplies data set are listed in Table A3.

Table A3. Variables of the FIRM_COMMOD, Commodities: Materials and Supplies, data set.

Variable	Description
stoimipaikkaID	Secure site ID
Syrtunnus	Secure company ID
Vuosi	Year
versioid	Statistical version
AineTarvKoodiCPA	Materials and supplies code Starting from the statistical reference year 2019, the European Union's CN nomenclature (Combined Nomenclature) will be used as the nomenclature of the inquiry on materials and supplies of manufacturing production. The CN nomenclature is the eight-digit classification of goods used in statistics on foreign trade. There will be changes in the nomenclature every year, so it is not possible to compile fully comparable time series between the statistical year 2019 and later. In

Variable	Description
	the data, the level of precision of the item varies, as the questionnaire can be answered at the 8- and 6-digit levels of the CN classification.
PanosTyyppiKoodi	<p>Input type code</p> <p>From the statistical year 2019, the input type code always has a value of "1", as quantity data for the inputs are no longer requested.</p> <p>Prior to the statistical year 2019, in addition to the values of purchases of materials and supplies, their quantity data were also inquired. In addition, the amount of total use was asked for separately defined material and article names. Because the record has only one quantity field, the answer related to total usage is on a different record from the answer to the value and volume information for purchases. The input type code tells which situation this is. The value of the input type code "1" refers to the value and volume data of the materials and supplies purchase and the value of the input type code "2" refers to the total use. Total usage was inquired from a fairly small set of titles – on those items of materials and articles for which the reported purchases were not believed to adequately reflect the actual use of materials and articles. Also, no monetary value was asked for total usage, so its value field is empty.</p>
MaaraMittayks1	<p>Quantity of the material or supply in the primary unit of measurement</p> <p>Quantity or total use of purchased materials and supplies by unit of measurement; see input type code. Units of measurement vary by item. Nearly 40 different measurement units are in use. Therefore, there are great restrictions to summing up volume data. Measurement units can describe weight or gross tonnage, length, area, capacity, number (item or pair), power and energy, gross caloric value, etc.</p> <p>As of the statistical year 2019, quantity data are no longer inquired.</p>
TuotanArvo	<p>Value of purchases</p> <p>The purchase value of materials and supplies delivered to the company without VAT. However, the cost of transport with the company's own vehicles is not included in the purchase value. The value field of purchases is by definition empty when the input type code = "2".</p> <p>Purchased materials and supplies covers materials and supplies intended for the manufacture of goods:</p> <ul style="list-style-type: none"> - raw materials, - semi-finished products, - additives, and - accessories. <p>Data collection covers materials and supplies purchased from outside the enterprise (legal unit) during the calendar year, regardless of the year of use.</p>
TuotanTietoVarmuus	<p>Certainty of production observation data or status of processing</p> <p>Generated programmatically or manually when creating a new observation or updating an observation.</p> <p>Possible values:</p> <p>1 = Data received normally</p> <p>2 = Approved</p> <p>3 = Manually estimated</p> <p>5 = Uncertain information (title, value or amount)</p> <p>4, 6, 8, 9 = Quantity data estimated</p> <p>Z, missing data</p>

Variable	Description
	<p>Missing individual value and quantity data have been estimated manually on the basis of data from previous years and data available from other statistics and sources.</p> <p>The programmatic evaluation of quantity data is based on the average price method. In this, the average price has been calculated item by item for answers that have contained both value and quantity information on purchases. When the value of the purchases of these so-called full answers has been at least a certain percentage of the value of all the answers for the item in question, the missing quantity information for the item is estimated by dividing the value of the purchases by the average price per item. Quantity data were last requested for the statistical year 2017.</p>
mitta1ti	Unit of measure
Tol2008Vuosi	Industry code of the site (TOL2008)

Data access

Statistical legislation and the data protection and confidentiality practices specified in legislation are applied in compiling and releasing the data. The releasing of microdata is subject to a user licence. The price of the assignment is determined on the basis of its extent, requirements, and the mode of use of the data. More information is available from Statistics Finland's research services: tutkijapalvelut@tilastokeskus.fi.

Technologies

The target group of the industrial production materials and supplies survey is selected from the reporting units of the Industrial Commodity Inquiry. Since the statistical year 2017, the materials and supplies survey has had its own separate inquiry. Before that, it was done in connection with a commodity inquiry. However, for the statistical years 2017 and 2019, purchases of materials and supplies have still been asked of a small group of companies in connection with the commodity survey in the spring of the year following the statistical year, when the actual survey of materials and supplies was conducted only in autumn.

Data are collected from sites or from combinations of sites. Information on the combinations of sites is presented in the material in the form of single establishments, i.e., distributed programmatically to the different sites of the enterprise.

Future developments

There are minor changes in the nomenclature of materials and supplies from year to year, but not every year. For this reason, it is often not possible to compile comparable statistics between years using an accurate nomenclature. At a more

aggregated heading level, such as at the 4-digit level of the heading (TOL 2008 level) or the 6-digit level (CPA level), statistics can be compared between years.

Statistics Finland calculates the value of domestic material consumption as part of the annually statistics on economy-wide material flow accounts. The consumption of domestic materials includes materials taken into use from Finnish nature, to which the weight of imported goods is added and from which the weight of exports is subtracted. The material intensity is obtained as a ratio of domestic consumption of materials to GDP. Both domestic material consumption and material intensity are among the UN's indicators for sustainable development.

Gaps and opportunities

Data on materials and supplies are inquired from all manufacturing establishments of enterprises with at least 20 persons (i.e., employees and entrepreneurs), and in certain cases smaller enterprises than this. The data supplier unit is an enterprise or an establishment of an enterprise whose main activity is in manufacturing (in the industries mining and quarrying = industry B or manufacturing = industry C). Thus, even establishments of non-industrial enterprises engaged in industrial activity are included in the inquiry.

The size of the target group has been 2,000–2,400 enterprises / sites each statistical year. The response rate has varied between 60% and 70%.

The data describe production in Finland during a calendar year. The quality and coverage of materials and supplies data are inferior to that of import data and are not imputed accordingly.

In the data collections prior to the statistical year 2019, quantity data were also asked for purchases of materials and supplies made for manufacturing production. In addition, total use for certain material and supply headings during the calendar year were asked, regardless of the year of purchase or acquisition. Total use included materials and supplies purchased from outside the enterprise (legal unit) and products prepared for further processing in the enterprise. In order to reduce the response burden, questions on quantity data and total use were discontinued after the statistical year 2019.

5.2. Industrial output

Description

The statistics on industrial output contain data on sold and total outputs by commodity heading. The data are collected annually from enterprises or their establishments in the industry classes of Mining and Quarrying B, and Manufacturing C.

Data are inquired on the value and volume of all goods produced by an enterprise / establishment and sold outside the enterprise. The units used for measuring physical volumes vary according to commodity heading, and there are nearly 40

units in use. In addition, data are inquired on the volume of total output of certain separately defined commodities (in the case of vessels, the value of total output).

Sources of data

The data are collected from enterprises or establishments of enterprises. The data describe production in Finland during a calendar year. An establishment refers to an economic unit owned or controlled by one enterprise that produces goods and services of mainly one particular type usually at one location.

Because the data describe unit-level business activity, the use and release of the data are subject to general rules on data control. Value and quantity data for certain categories of commodities are encrypted at the request of the reporting enterprises. The number of companies is confidential information in all production items.

From a company's or establishment's total production, the values and usually also the quantities of production sold outside the company during the calendar year have been inquired. In addition, the quantities of total production have been asked for separately defined products.

The enterprises and establishments of the industrial output inquiry have been selected so that the representativeness requirement imposed by the EU's PRODCOM Regulation, or at least 90% of the production value of each manufacturing industry must be included in the statistics. Thus, information on manufacturing production is, as a rule, collected from all establishments of enterprises with at least ten persons. In addition, in some manufacturing industries, the inquiry also includes some smaller establishments of enterprises in order to fulfil the EU's representativeness criteria. The size of the population has been around 3,000 to 3,500 sites in recent years.

Data set properties

The data supplier unit in the statistics on manufacturing commodities is all manufacturing enterprises with at least 10 persons (i.e., employees and entrepreneurs), all manufacturing establishments of non-manufacturing enterprises with at least 20 persons, and even smaller enterprises so that at least 90% the production value of each manufacturing industry will be included in the statistics. The data supplier unit is an enterprise or an establishment of an enterprise whose main activity is in manufacturing (in the industries mining and quarrying = industry B or manufacturing = industry C). Thus, even establishments of non-industrial enterprises engaged in industrial activity are included in the inquiry.

Since 1997, the classification of commodity headings referred to in the industrial production statistics has been based on the PRODCOM classification of industrial production of the European Union updated annually. The PRODCOM classification contains 8-digit product headings.

The PRODCOM classification did not include all product groups, for which reason it was supplemented with additional national headings. Some of the PRODCOM

headings were also divided into national subheadings. The national product heading codes comprise 10 digits. The first four digits of the codes correspond to the code of the standard industrial classification of the European Communities (NACE Rev. 2) and thus to the first four digits of Statistics Finland's industrial classification TOL 2008. The first six digits of the code correspond to the Classification of Products by Activity (CPA) of the European Community.

Starting from the statistical reference year 2019, the European Union's CN nomenclature (Combined Nomenclature) has been used as the nomenclature of the inquiry. The CN nomenclature is the eight-digit classification of goods used in statistics on foreign trade.

The variables of the industrial output data set are listed in Table A4.

Table A4. Variables of the *FIRM_COMMOD, Commodities: Products, data set.*

Variable	Description
stoimipaikkaID	Secure site ID
Syrtunnus	Secure company ID
Vuosi	Year
Prodcomkoodi	Prodcom code The PRODCOM code, i.e., product name, length 8 or 10 digits. Since the statistical year 1997, data on industrial production statistics have been compiled according to Eurostat's PRODCOM classification, supplemented by national specifications, i.e., additional national headings.
TuotanTyyppi	Type of production of the commodity The production type code indicates whether the production of the commodity requires more than the value and quantity of the production sold. Possible values: 1 = Value and volume of production sold. 2 = Volume of total output (based on Eurostat's or Statistics Finland's own needs). 3 = Value of total production in question (Large vessels delivered, product headings starting with 301). Total output = the volume of output produced during the accounting year, regardless of whether it was produced for sale or further processing within the same legal unit.
MaaraMittayks1	Production volume in the primary unit of measurement, i.e., quantity1 Volume of production sold in the primary unit of measurement, i.e., quantity 1, when TuotanTyyppi = 1, 2. In the product data, the primary measurement unit is the measurement unit required by the EU. This also concerns both the volume of sold production and total production. If the primary measurement unit is indicated with a hyphen (-), volume data are not inquired at all for the product heading concerned. Then it is either a question of a service heading or a heading with a very heterogenic content, such as a residual category heading on which data cannot be asked only for one measurement unit.

Variable	Description
	Units of measurement vary widely.
MaaraMittayks2	<p>Production volume in the secondary unit of measurement, i.e., quantity2</p> <p>The secondary measurement unit in the product data is the measurement unit used for national needs. The motive is often that data suppliers can give volume data precisely for this measurement unit. This also concerns the volume data of both sold production and total production. If secondary volume data are not inquired, the corresponding measurement unit is indicated with a hyphen (-).</p>
TuotanArvo	<p>Value of production</p> <p>Production value, EUR, when TuotanTyyppi = 1, 3. There is a separate observation (row) for each production type code in the table.</p> <p>-----</p> <p>Production sold = Value of products and semi-finished products sold outside the enterprise during the calendar year, EUR, when TuotanTyyppi = 1 (Sold Production)</p> <p>-----</p> <p>Value of total production, EUR, when TuotanTyyppi = 3 (Total production value; rare, applies only to product headings starting with 301 of delivered large vessels).</p> <p>In the manufacture of large vessels, when TuotanTyyppi = 3, it is usually a matter of several years of project and production value information for a given calendar year not including the value of the entire vessel, but only the part of the vessel's value according to the year's readiness. Thus, partial revenue recognition is used according to the stage of completion of the vessel.</p>
TuotanTietoVarmuus	<p>Certainty of production observation data or status of processing</p> <p>Generated programmatically or manually when creating a new observation or updating an observation.</p> <p>Code 1 = Data received normally</p> <p>Code 2 = Approved</p> <p>Code 3 = Manually estimated</p> <p>Code 4 = Imputed; this situation is an industrial so-called non-rotational sample, a mini-company whose entire answer, i.e., all item information, is imputed at once. In a mini-company, the total number of employees is between 10–19.</p> <p>Code 5 = Uncertain; in this situation, the security code is usually given manually to the individual reporting agent and its item. (The choice of the item code itself, the value of the item or the quantity / quantities may be uncertain. If the item code is uncertain, it may be taken directly from customs export data in a situation where the corresponding production item code has not been obtained from the notifier himself.)</p> <p>Code 6 = Quantitative data on production have been estimated; in this situation, the quality of the data is better than in the case of code 8 and therefore the quantitative data with code 6 can also be used for national statistics, Industrial Production Statistics.</p> <p>Code 7 = Programmatically estimated; in this situation, the entire response of the collection unit, i.e., all product name information, has been evaluated at once, i.e., the unit has not responded to the inquiry in any way. The total number of employees of the company</p>

Variable	Description
	<p>can be any, but at least 10 people, i.e., a company covered by the commodity inquiry in general.</p> <p>Code 8 = Production target data have been estimated for the EU (data not used for national statistics), in which case the assessment has been made exclusively for EU needs and the quality of the data is therefore worse than other estimated data, e.g., data reliability code values 3–4, 6–7, 9. Note: In the case of benign manually assessed information, material handlers have been instructed to use security code 2, 3, or 6 and not a weaker security code 8.</p> <p>Code 9 = Quantity data evaluated programmatically in the situation other data MaaraMittayks1Arviointi or MaaraMittayks2Arviointi (Commodity quantity evaluation codes 1 and 2) = 1 Estimation OK, always.</p>
MaaraMittayks1Arviointi	<p>Quantity estimation code in the primary unit of measurement</p> <p>The programs that generate the estimation codes MaaraMittayks1Arviointi and MaaraMittayks2Arviointi estimate programmatically the missing production (and purchases) *** volume data *** simultaneously. The estimation is based on weighted average price data and requires that the quantity information of the incomplete observation be present in the production stock and that the relative share of the full answers of the item in the total value of the item is large enough to justify the assessment, i.e., at least 40%.</p> <p>The programmatic assessment is performed using weighted average price data (= value / quantity -> quantity = value / average price) calculated from the full responses of other respondents to the same commodity item. For programmatically evaluated observations, the flagging code is updated to MaaraMittayks1Arviointi = 1 or MaaraMittayks2Arviointi = 1, depending on the quantity data to be processed.</p> <p>1 Quantity data is programmatically estimated by price information 2 Quantity data could not be estimated from price information [empty]No need to be estimate quantity data programmatically</p>
MaaraMittayks2Arviointi	<p>Quantity estimation code in the secondary unit of measurement</p> <p>1 Quantity data is programmatically estimated from price information 2 Quantity data could not be estimated from price information [empty]No need to be estimate quantity data programmatically</p>
mitta1ti	Unit of measure for quantity 1
mitta2ti	Unit of measure for quantity 2
Toi2008Vuosi	Industry code of the site (TOL2008)
Salattu	Value or quantity information is concealed
versioid	Statistical version

Data access

Statistical legislation and the data protection and confidentiality practices specified in legislation are applied in compiling and releasing the data. The releasing of microdata is subject to a user licence. The price of the assignment is determined on the basis of its extent, requirements, and the mode of use of the data. More

information is available from Statistics Finland's research services: tutkijapalvelut@tilastokeskus.fi.

Technologies

The target group of the inquiry is mainly formed from Statistics Finland's Register of Enterprises and Establishments. The latter provides new enterprises and establishments for the statistical year, as well as closure and other change data for all observation units compared to the previous year, and data describing the size by reference period. The statistics also cover subcontracting companies that carry out contract manufacturing on behalf of another company. The statistics only apply to the production of the enterprise (legal unit) in Finland.

Data are collected from sites or from combinations of sites. As of 2013, the information on the combinations of sites is presented in the material in the form of single establishments, i.e., distributed programmatically to the different sites of the enterprise.

From the statistical year 2005, the response burden of the smallest industrial enterprises in inquiries was reduced to almost half. In order to reduce the response burden, for a group of 10–19 person industrial enterprises, of which there are about 1,550 in Finland, a set of survey frames was formed, from which a representative rotational sample is taken annually. Each small enterprise is included in the survey as a rotational sample in either even or odd statistical years. However, companies that have not responded in their own round to the survey (survey unit loss) are included in the survey for as long as they respond. The response data of the companies on hold from the survey are imputed (estimated by statistical methods) into the total statistical data programmatically.

In the evaluation method, one general multiplier is first calculated. It is based on the average annual change in the survey response data (statistical year vs. previous year). The calculation of the multiplier takes into account the companies appearing in the response data in both years and the identical production items appearing in both years. From this synchronized set of observations, those observations in which the change in value / quantity has not been within moderate limits, in one direction or another, are removed. The multiplier is calculated separately for value and for quantity data. This general multiplication factor therefore does not depend at all on the industry or the PRODCOM heading.

For the small companies on hold from the survey, any item changes between the consecutive years will first be taken into account. This is done in proportion to the response data of enterprises of all sizes that appear in the most recent statistical year. This item-specific information is multiplied by the general multiplication factor, the value information by its own factor and the quantity information by its own factor. This gives the product name-specific value and quantity data for the company / establishment on hold from the survey, imputed for the statistical year. The patched response data of small industrial enterprises of 10–19 people are included in the unit-level aggregate, in addition to the genuine inquiry responses of enterprises and

sites. The statistical year 2008, when the new Industrial Classification TOL 2008 and the revised PRODCOM nomenclature were introduced, was exceptional in the survey of small enterprises: all 10- to 19-person industrial companies were included in the survey.

In addition, individual physical target data missing from the inquiry responses are estimated in different ways, but they can also be missing from the final data. The missing response data from the companies not answering the survey are estimated. This assessment is mainly done programmatically, and partly also manually.

Future developments

There are minor changes in the nomenclature of materials and supplies from year to year, but not every year. For this reason, it is often not possible to compile comparable statistics across years using an accurate nomenclature. At a more aggregated heading level, such as at the 4-digit level of the heading (TOL 2008 level) or the 6-digit level (CPA level), statistics can be compiled across years. The products0419_prodc2019 file is available separately, where the main corresponding product code of 2019, if any, has been retrieved for the product codes of different years using the classification keys.

Gaps and opportunities

The response rate of the industrial output inquiry has been about 70–90% annually. The smallest 10–19-person industrial companies or their sites have the lowest response rate. If response data are not obtained directly from the reporting enterprise, the aim is to assess the data in as many cases as possible on the basis of the previous year's commodity response data and the financial statements for that statistical year. Often, the information on the company's product range found on the company's website can also be used to help select suitable product items.

5.3. Environmental protection activities

Description

The statistics on industrial environmental protection expenditure describe the expenditure by industry arising from environmental protection. The statistics show the magnitudes of investments in environmental protection and operating expenditure by industry and use (by sector of the environment).

The statistics are intended for the needs of social decision-making, companies and their interest groups, and research. The statistics make it possible to compare expenditure on environmental protection between different industries. The statistics follow the statistical principles formulated by the EU's statistical office, Eurostat, which ensures the comparability of the data with the corresponding statistical data of other European countries and international organizations.

Sources of data

The data required for industrial environmental protection expenditure statistics are collected through an annual survey sent to around 2000 industrial sites. The survey concerns environmental protection expenditure incurred in the previous year and can be answered either on paper or via the Internet using an electronic form.

In the database based on Statistics Finland's register of enterprises and establishments, the basic framework of statistics consists of enterprises of at least one person whose industry is mining and quarrying, industrial manufacturing, energy supply, or water purification and distribution. The survey covers the following sections of the industry classification TOL 2008

B Mining and quarrying (05–09)

C Industry (10–33)

D Electricity, gas, steam, and air conditioning supply (35) and
from Section E - Water collection, treatment, and supply (36)

Data set properties

The statistics cover industrial industries, i.e., mining and quarrying, industrial manufacturing and energy supply, water treatment and distribution, sewage and waste management, households and the state and municipalities. The industry breakdown is in accordance with Statistics Finland's classification TOL 2008 based on the EU standard (Industry Classification 2008, Statistics Finland, Manuals 4, Helsinki 2008).

Statistics on environmental protection expenditure include:

- environmental protection investments
- operating and maintenance costs of environmental protection equipment
- other operational expenditure on environmental protection, such as research and development expenditure, administrative expenditure and miscellaneous charges and compensation

Investments in environmental protection include investments to reduce and treat emissions. Measures to reduce emissions change the production process in such a way that the formation of emissions from production in relation to production volumes is reduced. Investments in environmental protection intended to treat emissions are purifiers and other accessories or solutions, the introduction of which does not substantially change the production process itself.

Environmental protection is defined in these statistics as an activity intended to reduce harm to the physical environment or which is essentially related to the reduction of such harm. Such measures include the treatment of emissions and waste, the prevention of their generation, environmental monitoring and control, environmental management, training and information, remediation of environmental damage, and research and development to reduce the environmental impact of production. In these statistics, material efficiency such as switching to renewable

energy or recycling, energy saving, and occupational safety measures are not included in environmental protection.

The variables of the environmental protection expenditure accounts data set are listed in Table A5.

Table A5. Variables of the environmental protection expenditure accounts data set.

Variable	Description
stoimipaikkID	Secure site ID
Syrtnunnus	Secure company ID
Vuosi	Year
Toi2008Vuosi	Industry code of the site (TOL2008)
inv_kohde_ilm	Value of environmental investment: Air and climate protection (NOx, SOx, CO, VOC, CH4, CO2, CFC, N2O, particles) The capital investment an enterprise spends on environmental protection measures whose primary aim is to create process changes that reduce emissions; treatment of emissions; measurement and monitoring, research laboratories; other measures.
inv_kohde_jate	Value of environmental investment: Waste management (ordinary and hazardous waste) The capital investment an enterprise spends on environmental protection measures whose primary aim is waste prevention; waste collection and transportation; waste treatment and disposal (including investment-related protection of soil, surface water, and groundwater); measurement and monitoring, research laboratories; other measures.
inv_kohde_maa	Value of environmental investment: Protection of soil, surface and groundwater The capital investment an enterprise spends on environmental protection measures whose primary aim is prevention of absorption of the contaminant; remediation of contaminated soil, surface water, and groundwater; landfill landscaping (reported as an investment); measurement and monitoring, research laboratories; other measures.
inv_kohde_melu	Value of environmental investment: Noise and vibration control The capital investment an enterprise spends on environmental protection measures whose primary aim is source prevention; preventing the spread outside the establishment or property; measurement and monitoring, research laboratories; other measures.
inv_kohde_vesi	Value of environmental investment: Wastewater treatment (solid, BOD / COD, N, P, metals, microbes) The capital investment an enterprise spends on environmental protection measures whose primary aim is process changes to reduce water pollution; sewers; wastewater treatment; cooling water treatment; measurement and monitoring, research laboratories; other measures.
inv_kohde_biodiv	Value of environmental investment: Biodiversity and landscape protection

Variable	Description
	The capital investment an enterprise spends on environmental protection measures whose primary aim is the protection of biodiversity and landscape: restoration of species, habitats, and landscape, rehabilitation and clean-up of water bodies; measurement, monitoring, research laboratories, etc.; other measures.
inv_kohde_sateil	Value of environmental investment: Radiation protection (excluding safety and occupational safety of nuclear power plants) The capital investment an enterprise spends on environmental protection measures whose primary aim is environmental protection; transportation and treatment of high-level waste; measurement, monitoring, research laboratories, etc.; other measures.
inv_kohde_ytuke	Value of environmental investment: Environmental research and development The capital investment an enterprise spends on environmental protection measures whose primary aim is protection of ambient air and climate; water protection; waste; soil, surface water, and groundwater protection; noise and vibration control; biodiversity and landscape protection; protection of species and habitats; radiation protection; other environmental research.
inv_kohde_muu	Value of environmental investment: Other environmental protection measures and environmental management costs The capital investment an enterprise spends on environmental protection measures whose primary aim is general environmental management; public administration, legislation, and the like; environmental management; training, orientation, and information; compensation and compensatory expenses; measures whose costs cannot be allocated; measures not specified elsewhere.
inv_type	Type of environmental investment: External or internal The environmental investment type code indicates whether it is an external or an internal investment. Possible values: 0 = not specified (2014–2016) 1 = external investment 2 = internal investment External investment is investment in the treatment, purification, and prevention of the release of emissions and waste into the environment. They do not substantially change the operation of the production process, but may require minor changes in process technology. They are usually various cleaners and other accessories or, for example, structures required for waste treatment. External investments as a whole are investments in environmental protection (the environmental protection share is usually 100%). The investment can be, for example, a machine, a building, land, etc. Internal investments in environmental protection improve the operation of the process by preventing the generation of emissions and waste. In practice, they often mean modernizing the production technology itself. Measures to reduce emissions change the production process in such a way that the formation of emissions from production in relation to production volumes is reduced.

Variable	Description
	Internal investments are usually only part of the total investment made. In this case, the share of the environmental protection investment is reported, i.e., the additional expenditure due to the sub-investments improving the level of environmental protection and its share of the total investment (%). The investment can be, for example, a machine, a building, land, etc.
men_ilma	Operating and maintenance costs: Air and climate protection (NOx, SOx, CO, VOC, CH4, CO2, CFC, N2O, particles)
men_jate	Operating and maintenance costs: Waste management (ordinary and hazardous waste)
men_maa	Operating and maintenance costs: Protection of soil, surface water, and groundwater
men_melu	Operating and maintenance costs: Noise and vibration control
men_vesi	Operating and maintenance costs: Wastewater treatment (solid, BOD / COD, N, P, metals, microbes)
men_biodiv	Operating and maintenance costs: Biodiversity and landscape protection
men_sateil	Operating and maintenance costs: Radiation protection (excluding safety and occupational safety of nuclear power plants)
men_ytuke	Operating and maintenance costs: Environmental research and development
men_muuu	Operating and maintenance costs: Other environmental protection measures and environmental management costs
men_tyyppi	Type of operating and maintenance cost Possible values for the operating and maintenance cost type code are: For the years 2014 - 2016 1 = own work 2 = external cost From 2017 onwards: 11 = salary costs 12 = energy and material costs 13 = other operating expenditures Expenditure on environmental protection covers all expenditure on environmental protection, with the exception of purchases of environmental protection services from third parties. Expenditure is not only the cost of operating and maintaining one's own plant, but also includes other expenditure on environmental protection, such as research and development (reported as 'other operating expenditure' excluding salaries).
opa_ilma	Purchased services: Air and climate protection
opa_jate	Purchased services: Waste management
opa_maa	Purchased services: Soil, surface water, and groundwater protection
opa_melu	Purchased services: Noise and vibration control
opa_vesi	Purchased services: Wastewater treatment
opa_biodiv	Purchased services: Biodiversity and landscape protection
opa_sateil	Purchased services: Radiation protection

Variable	Description
opa_ytuke	Purchased services: Environmental research and development
opa_muu	Services purchased: Other environmental protection measures and environmental management costs
opa_tyyppi	Type of service provider: Private company or public body Possible values for the service provider type code: 1 = environmental or other company 2 = municipality and/or state From 2017 onwards, the purchased services section also indicates administrative and official fees, such as ELY fees and payments based on producer responsibility (Rinki, Recser Oy, ERP Finland Oy, Elker Oy, etc.), as well as compensation costs. They are allocated to the category "Other environmental protection measures and environmental management costs".
tav_invest_avust_arvo	Investment grants Grants and subsidies for projects or measures to reduce environmental damage. Such subsidies include investment grants and interest rate subsidies granted by the Ministry of Economic Affairs and Employment, Business Finland Oy (formerly TEKES), and other organizations for environmental protection investments. Does not apply to energy saving investments and their subsidies.
tav_sivutuott_tuotot_arvo	Revenue from sales of by-products Revenue from the sale of by-products, which has incurred or would incur costs related to environmental protection. Such by-products include recoverable waste and process surplus products such as the sale of side stone or scrap iron.

Data access

Statistical legislation and the data protection and confidentiality practices specified in legislation are applied in compiling and releasing the data. The releasing of microdata is subject to a user licence. The price of the assignment is determined on the basis of its extent, requirements, and the mode of use of the data. More information is available from Statistics Finland's research services: tutkijapalvelut@tilastokeskus.fi.

Technologies

Environmental protection expenditure is recorded on the basis of its allocation, in accordance with the CEPA 2000 international classification of environmental protection measures and costs. (Classification of Environmental Protection Activities and Expenditure). CEPA categories include wastewater management, waste management, air protection, nature protection, and administration and other environmental protection.

All enterprises with at least 250 employees are included in the inquiry. Stratified sampling is used for enterprises with fewer than 250 employees. The statistics include the industries of mining and quarrying, manufacturing, energy supply, and

water supply. The data supply obligation of enterprises is based on the Finnish Statistics Act (280/2004, Section 14).

Future developments

The responses to the industrial environmental protection expenditure inquiry are checked at Statistics Finland to minimize measurement errors. Non-response is taken into account when increasing the data to cover all industrial activities in Finland.

Gaps and opportunities

Due to the sampling nature, there are always statistical uncertainties associated with the results. However, the sampling design used aims at obtaining comprehensive and more reliable statistics on the environmental costs of large industrial enterprises, which are the most significant. The response rate to the questionnaire sent to around 2000 sites has been 70–80% in recent years.

6. Built environment

Milja Räisänen, Tiina K. M. Karppinen, Päivi Malmi, Janne Pesu

6.1. The built environment information system RYTJ

Description

The built environment information system is a new national data system that will bring together the most relevant building and land use planning information. A new system is needed to produce up-to-date, high-quality, reliable information about the built environment. The development of the system is based on the objectives set in the government programme on digitalization of the built environment.

The data system is to be utilized in decision-making and processes related to land use planning and building. The system will create new opportunities to use information in both public administration and business and will facilitate access to information about planned changes in the area for anyone who is interested.

The development and construction of the minimum viable product of the built environment information system is scheduled to be completed in a four-year period from 2020–2024. In 2021, the implementation of the new system (incl. technical implementation) was defined.

Sources of data

Information on zoning plans and building permits will be compiled and processed into a coherent and accessible form. The system is designed to work with other platforms, and they can retrieve information from each other. Municipalities will submit land use and building data in a defined standardized format.

In the future, so-called core data on land use planning and buildings (e.g., use, planning permission) will be available in this new platform, from which other state information systems or other organizations in need of information will retrieve it. In turn, the new system will use, for example, real estate, apartment, owner, and infrastructure data from other systems.

Data set properties

The platform consists of two data resources, one for building data and one for land use planning. In the first phase, the information will be used by the public administration in its statutory activities.

The renewed Land Use and Building Act defines the information that must be obtained in digital form in the future. According to the current plan, the data to be exported to the built environment information system are:

Land use planning:

- Information on the stage of the plan
- Plan proposal as a data model
- Approved plan as a data model
- Legally valid plan as a data model
- Description of the plan
- Information about building ban
- Information about building restriction
- Information about action restriction
- Plot allocation plan
- Plans for common areas
- Building order
- Urban development plan
- Municipal land policy programme and municipal land policy summary

Building permits:

- Building permit decision
- Landscape-work permit decision
- Demolition permit decision
- Exemption permit decision
- Construction site plan data model
- Construction site realization data model
- Operation and maintenance instructions for the subject of the building permit

The data are to be stored only once, in an agreed format, in the national system, where they will be up-to-date and reliably available to all systems.

Data access

In the first phase, the information will be used by the public administration in its statutory activities, but eventually, through the system, different actors will be able to receive necessary land use and building information, for example:

- Decision-makers will receive more detailed information for assessment and foresight, which will guide the use of areas and properties.
- The municipality will receive information that can be used, for example, to assess the need for repairs in the municipality's properties in the near future.
- The owner of the building will receive the core information of the site (e.g., building right and planning of the surrounding area) and can maintain, for example, repair information related to the renovation of the building.
- The rescue department will receive information on the specific features of the site, such as conservation decisions.

- The tax authorities will receive up-to-date information, for example, on property taxation.
- Companies will receive information for service development.

Technologies

-

Future developments

The development of the system has only just begun. SYKE is responsible for the development work. The progress of the project can be followed on the Ministry of the Environment website: <https://ym.fi/en/project-ryhti/the-built-environment-information-system>

Gaps and opportunities

-

6.2. Emission database for building products, services, and systems, CO2data.fi

Description

The [CO2data.fi](https://co2data.fi) online service provides objective data on the climate impact of construction products used in Finland, such as the carbon footprint and handprint, material efficiency, and recyclability. The data harmonises the calculation of greenhouse gas emissions throughout the life cycle of buildings and facilitates the design of a low-carbon building. The database was published in March 2021 and is still being developed.

Sources of data

The data are based on public sources, mainly environmental declarations for construction products, on the basis of which comparisons, selection, and calculation of averages have been made together with experts in the construction products industry. The Finnish Environment Institute SYKE is responsible for the maintenance and development of the database on behalf of the Ministry of the Environment. Emission data has been compiled into easy-to-use results pages (see Figure A15), in addition to which more detailed background studies can also be found. All data is also available in machine readable format (json file).

Data set properties

The database provides, for example:

- the carbon footprint of construction products
- the carbon handprint of construction products
- the scenarios for the recycling and recovery of construction products at the end of their life cycle
- the waste percentages on construction sites
- the technical lifetimes of frequently replaced products
- transport emissions data
- construction emissions data
- emissions data for different forms of energy and scenarios for the development of their carbon footprint for the coming decades
- emissions data for waste treatment

Ceramic tile for walls		0.77 kg CO ₂ e /kg
Keraaminen seinälatta Keramiska vägglattor		CONSERVATIVE VALUE FOR BUILDING PERMIT CALCULATIONS, GWP (A1-A3)
ADD TO LIST		
Environmental indicators		
TYPICAL VALUE, GWP (A1-A3) Not for building permit calculations	0.64 kg CO ₂ e /kg	
CONSERVATIVE VALUE CONVERSION FACTOR	1.2	
CARBON HANDPRINT	D1 Re-use and material recycling D2 Energy recovery D4 Carbon storage effect D5 Carbonation	
WASTE FACTOR Loss at building site	1.1	
SHARE OF RENEWABLE MATERIALS (%)	-	
SHARE OF RECYCLED MATERIALS (%)	-	
SHARE (%) AND TYPE OF HARMFUL SUBSTANCES (SVHC)	<0.1 %	
END OF LIFE SCENARIO (%)	Reuse	0 %
	Recycled as secondary rawmaterial	90 %
	Energy recovery	0 %
	Final disposal	10 %
	Hazardous waste to be removed from use	0 %
CONVERSION FACTOR	Weight, kg/m ²	16
General description		
CATEGORIES	Floorings and surface materials Mineral materials and glass (excluding concrete) Paints, screeds, and mortars Supplementary products	
RELATED HARMONISED STANDARD(S)	EN 14411:2016 Ceramic tiles	
CLASSIFICATION / TALO 2000	411 Keraamiset laatat	
DESCRIPTION	Ceramic floor tiles: The proposed generic values for the ceramic floor tiles are taken as average values from a range of EPDs from relevant markets. Ceramic wall tiles: The proposed generic values for the ceramic wall tiles are taken as average values from a range of EPDs from relevant markets. Representative data for products purchased by the construction sector in Finland	
TECHNICAL DESCRIPTION	The biggest embodied carbon impacts from ceramic tiles comes from the manufacturing of the product (> 60 %). The emissions from raw materials account for approximately 20 – 30 % of the GWP of the product.	
MARKET	In the ceramic tiles market, there is no domestic manufacturing in Finland at all. Majority of the ceramic tiles are imported from the Mediterranean basin (Italy, Turkey, Spain).	
BACKGROUND REPORT	Download full background report	
ID	7000000539	

Figure A15. An example of information given for a specific construction material (here ceramic tile for walls) in the emissions database for construction.

The database contains only general and typical information describing Finnish construction. It does not contain information about individual products or companies.

The data in the database have been compiled by the Finnish Environment Institute SYKE in collaboration with environmental experts and construction professionals. More than 100 experts and professionals have participated in the creation of the database.

The database is based on existing public information and has been compiled from various sources, mainly environmental statements (including RTS EPD, EPD Norge, Environdec, IBU, other generic data if necessary, e.g., ÖkobauDat, ICE, VTT, IVL). Based on this, comparisons, selection, and the calculation of averages have been made. Industry expert groups from different product categories have been involved.

Data on construction, transport, demolition, and waste management are mainly based on Finnish statistics and surveys. The database has been created together with the Swedish authorities and experts. Information in the database is updated regularly/yearly based on feedback received.

Data access

The service is open to everyone free of charge.

Technologies

Currently, data is available both via a simple user interface, CO2data.fi, and in machine readable format (json file) from https://co2data.fi/api/co2data_construction.json.

Future developments

Database coverage will be enlarged to include infrastructure construction and a more advanced API will be developed. More data will also be added based on user feedback, i.e., when new generic products gain market share and environmental importance.

Gaps and opportunities

Identified in future developments.

6.3. Construction and demolition waste

Description

Construction and demolition waste is monitored nationally and for the EU, but the monitoring is less precise than the monitoring of MSW.

Sources of data

The amount of waste produced in the construction sector in Finland is available in the national waste statistics by Statistics Finland (Statistics Finland, 2021b). In the waste statistics, neither the recycling rate nor the treatment types for waste from the construction sector are available.

Waste generated by sector and type in 2018, 1,000 tonnes per year

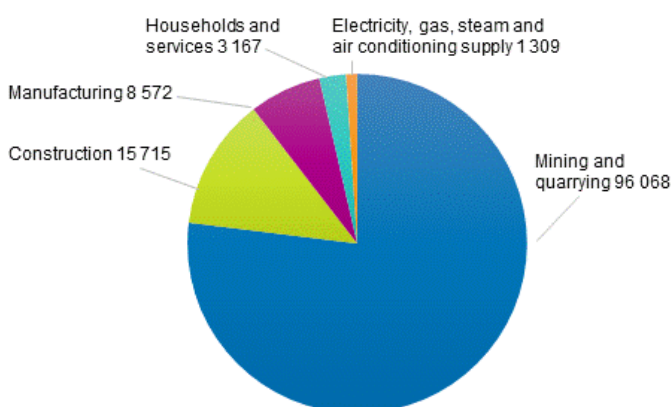

Figure A16. Generation of waste by sectors in 2018 (Official Statistics of Finland, 2018).

SYKE and Statistics Finland compile data to monitor the development in the recycling of MSW, as well as construction and demolition waste, towards the European targets. The data is available in the CKAN database supported by the environmental administration ([link](#)) (Merilehto & Salmenperä, 2021). The recycling rate is calculated with the WStat calculation method that excludes soils.

Data set properties

National waste statistics and EU reporting on MSW, as well as construction and demolition waste, are available with a delay of 1.5 years. By the time of the writing,

the data for 2019 is the most recent. The data is updated annually, and is used for EU reporting, so monitoring is expected to be continued in the future.

Data access

The data is publicly available free of charge.

Technologies

-

Future developments

Construction and demolition waste is one of the largest waste types in Finland. It is also one of the focus topic areas in the National Waste Plan. The EU has set targets on the recycling of construction and demolition waste. Thus, it is expected that the monitoring of both the production and utilisation of construction and demolition waste will be improved in the near future.

Gaps and opportunities

Currently, there are considerable uncertainties in the monitoring of construction and demolition waste. Local data on waste streams could enhance the utilisation of construction and demolition waste.

7. Plastics

Tiina K. M. Karppinen

7.1. Studies on secondary plastic flows in Finland

Description

The Finnish Environment Institute SYKE has developed a model for estimating the secondary streams of plastic waste in Finland in the project *ALL-IN for Plastics Recycling (PLASTin)* and a mass balance for plastic waste flows in the project *Novel method for the accounting of forest ecosystems and circular materials (ENVECO)*. The estimate consists of data from national statistics, research projects, and the business sector.



Figure A17. Data sources and gaps for plastic flows in Finland (Hurskainen et al. 2021).

Sources of data

The estimate on plastic waste streams is produced by SYKE, but it combines data from various national sources. The availability of data on the production of waste is rather good, but the use of secondary plastics in products, rejects in treatment processes, diffusion to nature (e.g., littering), and exports are poorly known.

The overall data is openly available, but some of the background data cannot be opened due to business secrets. The estimate will be published as the project proceeds. The data is intended for open use by all stakeholders interested in positively contributing to the circular economy of plastics.

Data set	Source
Plastic waste, mixed MSW, treatment types	MSW statistics, Statistics Finland
Plastic packaging waste	Producer responsibility statistics, PIRELY
Plastic packaging waste collected in regional collection points and arriving at terminals	RINKI
Waste PET bottles returned to the deposit system	Palpa
Storage of plastic waste	YLVA database
Plastics in mixed MSW	Suomen kiertovoima ry KIVO, Koostumustietopankki
Plastics sorted and recycled	Environmental permits of individual plants
Plastics exports	Uljäs database, Customs

Data set properties

The data is displayed as a flow chart that separates the different processing steps and plastic waste streams in the most detailed way possible. Updating of the estimate is uncertain and depends on future research activities. The accuracy of the data was monitored by offering the data to individual experts and stakeholders to assess.

Data access

The compiled, national data can be found in a report that is available online free of charge.

Technologies

The data was compiled manually from multiple sources. Some of the data (e.g., waste statistics) can be found from open databases, some data is from databases with limited access (e.g., the YLVA database), and some of the data is collected directly from individual companies via interviews.

Future developments

The use of plastics as well as plastics waste globally has attracted considerable attention due to its effect on the climate, as well as littering. In Finland, recycling of plastics from households has a high potential for increasing the recycling rate of municipal solid waste to reach the EU-wide targets.

Gaps and opportunities

Since plastics are a diverse group of materials with different qualities and different paths in the recycling system, more detailed knowledge of the streams of different types of plastics would be needed. In addition, more data on the use of secondary materials could be beneficial for the circular economy.

8. Other data sources for circular design approaches

Tiina K. M. Karppinen, Jani Salminen

8.1. Geographic data on the circular economy in the Liiteri database

Tiina K. M. Karppinen

Description

The Finnish Environment Institute SYKE has built a geographic data tool that allows geographic visualisations and analyses on a variety of statistics. So far, the data related to the circular economy is limited to the accessibility of collection points, methane gas vehicle fuel stations, and e-car charging stations. However, many of the data sets available in Liiteri have an indirect connection to the circular economy. Liiteri has data related, for example, to climate, traffic, extraction of soils, land use, and the built environment that is closely linked to the circular economy. Liiteri consists of hundreds of map levels and over a thousand statistical data sets. (Finnish Environment Institute SYKE, 2020).

Sources of data

The service is one of those provided by the Finnish Environmental Institute SYKE. As the service can to large extent be used without any fees, the service is available for everyone. The statistics used in Liiteri are open data sets produced by a number of Finnish organisations.

Data set properties

The data is annually updated.

Data access

The service can be used without registration for basic browsing, as a registered user for more functionalities, and as a service client with a fee, when one has full functionality of the service in use. See: <https://liiteri.ymparisto.fi/>

Technologies

One can browse all the data sets in Liiteri and analyse them based on official geographical regions, such as municipalities, or define an individual geographical area to be studied. In addition to this, the Liiteri service offers service packages covering different themes relevant to many users to make using Liiteri easier and more approachable for different user groups. Service packages are available, for example, in relation to climate change, the cultural environment, and the planning of water management.

Future developments

The Liiteri service is constantly updated and improved. The circular economy is seen as a key strategic field of development in Finland. As more official data on the circular economy becomes available, it is possible that it will also be added to Liiteri.

Gaps and opportunities

The data sets related to the circular economy are presently scarce. Geographical data on material streams would be particularly useful for the circular economy.

8.2. Accounting of water use

Jani Salminen

Description

Water accounting has been developed for monitoring and modelling water use and efficiency in Finland. The accounting describes the intake of both surface and ground water for domestic consumption, industry, cooling, and irrigation in the Finnish economy. The publicly utilized information is available via the vesi.fi portal.

Sources of data

In Finland, the municipal water authorities supply fresh water and process sewage water. The usage of these is monitored carefully by the municipal water authorities, and the amount of these is the principal for the billing of the customers.

Private wells are not officially monitored and their water quality is the responsibility of their owners, as well the amount of water used and the adequacy of the water source.

The legislation regarding the monitoring of warm water usage was renewed in 2020. The new law requires that water usage is monitored more carefully with user-specific water meters. (Motiva Oy, 2020)

Data access

Data on water usage by manufacturing companies is seen as confidential information, and it is owned by the manufacturing organizations. For example, in the recent studies by Salminen et al., the researchers could access the data for research purposes, but it is not published openly and regularly for anyone to access. Nonetheless, some of companies do publish these figures as a part of their annual reports.

It would be interesting to discuss whether the openness of water usage data should be included in the demands of responsible, sustainable organizations.

Gaps and opportunities

Regarding water consumption, about half of the Finland's water usage is so-called virtual usage, where the consumption of water is related to the manufacturing processes of goods that are imported to Finland.

Therefore, it is important to also consider the global aspect of freshwater resources and their management in the originating countries. (Salminen, Tikkanen, & Koskiahho, 2017).

From the data perspective, it would require global open data resources on water usage in different countries and their industries, going down to the specific level of manufacturing and firms, and even unique plants involved in the manufacturing process. This would help both the authorities and consumers to monitor sustainable water usage.

8.3. Indicators for the development of circular business by Statistics Finland

Tiina K. M. Karppinen

Description

Statistics Finland has collected statistics related to circular business into a collection of 15 indicators in 8 themes. The indicators are related to circular design, material intake, production, logistics, trade and service, consumption, and waste, as well as reuse and recycling. The data is limited by the lack of comprehensive data on the circular economy, as well as limitations in the classification of circular business. (Statistics Finland, 2021b)

Sources of data

The data sets are openly available, free of charge, in Excel format from Statistics Finland: <http://www.stat.fi/tup/kiertotalous/kiertotalousliiketoiminnan-indikaattorit.html>.

The data sets are intended for monitoring of the development of the circular economy in Finland.

Data set properties

The data are based on official statistics. Most of the time series cover 2013–2018. The majority of the data is available on a national level, but some of the data sets are available regionally. Updating of the data series is uncertain.

Data access

The data is openly accessible free of charge. Reference is required.

Technologies

The data sets are based on numerous statistics that utilise both surveys and data from different databases.

Future developments

The need for the development of circularity indicators to monitor the national development is evident. The national circularity strategy has proposed similar indicators to be monitored. So far, it is unclear whether the data sets will be updated in the future.

Gaps and opportunities

The indicators only include branches of business that can be categorised as circular. However, the transition to a circular economy will take place in all branches of business. These indicators note the development in the waste management sector and services. However, they do not recognise the changes in traditional industries, such as the chemical, mechanical, or pulp and paper industry. Many of the most relevant changes that are at the core of a circular economy take place in businesses that cannot be recognised with these indicators and current statistics.

9. Waste

Tiina K. M. Karppinen

Data on waste can be found from many sources and databases. The national statistics (Appendix A, Section 9.1) describe the general picture and trends in waste generation and utilisation (Statistics Finland, 2021a). Statistics rely primarily on data provided by producers and handlers of waste in the national database of the environmental compliance monitoring system (YLVA) (Appendix A, Section 9.2) (Ministry of the Environment, 2021) and the producer responsibility statistics collected by the Pirkanmaa Centre for Economic Development, Transport and the Environment with producer responsibility organisations (Appendix A, Section 9.3) (Pirkanmaa Centre for Economic Development, Transport and the Environment, 2019). The development of waste amounts and recycling according to the National Waste Plan is monitored by the Finnish Environment Institute SYKE (Appendix A, Section 9.4) (Finnish Environment Institute SYKE, 2021).

In addition to these, there is data on transboundary shipments of waste, collected by SYKE (see Appendix A, Section 2.9.) and Finnish Customs (see Appendix A, Section 4.6.). Some waste-related data can also be found in other sources, such as the data of National Resources Institute Finland (Luke) on food waste and the Food Safety Authority's database on fertilizers (see Appendix A, Section 1.). The national advocacy organisation for the public waste management sector, Suomen Kiertovoima ry KIVO, also collects data on picking analyses on mixed municipal solid waste from households (Suomen Kiertovoima ry KIVO, 2021). Finally, different research projects provide a closer look at certain materials, waste streams, or locations, or model the system further.

The following sections provide basic information on the key sources of waste-related data in Finland.

9.1. National statistics on waste

Description

National statistics on waste by Statistics Finland provide a general picture of the production and utilisation of waste in Finland. (Statistics Finland, 2021a)

The data can be found in Statistics Finland's free-of-charge statistical databases (<https://pxnet2.stat.fi/PXWeb/pxweb/en/StatFin/>) under the general topic of Environment and Natural Resources and Waste statistics. The following data sets are currently available:

- 12cv -- Municipal waste by treatment method in Finland
- 12qw -- Waste generation by industry, 2018–2019
- 12qy -- Waste treatment by type of treatment, 2018–2019
- 001 -- Municipal waste by treatment method in 1997 to 2017

- 002 -- Waste treatment in 2015–2019 disaggregated by EU statistical waste classification
- 003 -- Waste generation in 2015–2019 disaggregated by EU statistical waste classification

Waste statistics are used in national steering as well as EU monitoring. They also provide valuable information on the circular economy from the products' end-of-life perspective.

Sources of data

The statistics are primarily based on waste management data from the YLVA database, as well as producer responsibility statistics.

Data set properties

National waste statistics and EU reporting on waste are available with a delay of 1.5 years. The latest data for 2019 became available in June 2021. The data are updated annually. All the statistics can be retrieved from the database as an Excel file or in other standardised formats.

Data access

The data are publicly available free of charge in the open online database maintained by Statistics Finland.

Future developments

It is expected that the collection of national waste statistics will continue, as it is part of the compulsory national monitoring. The data are used for EU reporting, so the monitoring is expected to be continued, and even expanded, in the future. Most likely, the focus on waste statistics will only increase due to the data needs in a circular economy.

Gaps and opportunities

More precise data on waste, such as local data on waste streams, more detailed data on different materials, and data on the recycling of specific materials or types of waste based on their origin could enhance in the utilisation of waste in the circular economy.

9.2. Production and treatment of waste in the national environmental compliance monitoring system (YLVA)

Data on waste produced, treated, or stored is collected from individual actors in a national compliance database for environmental permit monitoring (YLVA). For an individual batch of waste, the data required includes the type of waste (waste code and description), origin of waste, location of the activity, and the type of treatment. This data is available upon request and for a service fee from the Finnish Environment Institute SYKE. The data is primarily used in environmental compliance monitoring by local, regional, and national authorities. (Ministry of the Environment, 2021)

Sources of data

The YLVA database collects data on waste from actors who have environmental permits. Most, but not all, of the national waste streams are found in YLVA database.

Data set properties

YLVA includes data on waste streams arriving to or leaving treatment, as well as storage. The waste is categorised according to the EWC waste codes, and the type of treatment also follows a standardised categorisation. The database is constantly updated with new data. Corrections to the data are also made if necessary.

Data access

The waste-related data in YLVA are mostly available to the public upon request and for a service fee from SYKE. Access to some parts of the data may be limited. The data are available for monitoring purposes directly and for other purposes somewhat modified upon request.

Technologies

The accuracy of the data is monitored by local, regional, and national authorities. The data are also used in national statistics, other monitoring, and research.

Future developments

There is an ongoing broad development project in the administration to improve the data systems for material and waste streams. The YLVA database will also be further developed. Digitalisation could be further utilised so that manual dialling and checking of the data could be automated.

Gaps and opportunities

Since the database has primarily been constructed for compliance monitoring purposes, it is not an optimal source for waste statistics. The main problems in using YLVA's data in estimating national waste amounts are related to the double-counting of individual batches of waste and the loss of data on the origin of waste. Double-counting may occur, since the batches of waste are often taken through a series of treatment steps, such as pretreatment, storage, and final treatment, and the origin of the waste may be lost between the steps. One batch may be accounted first while it enters a pretreatment plant and again as it is entering an incineration plant. In addition, the geographical origin, as well as the activity in which the waste was produced (e.g., industry, municipalities), may be uncertain.

Some significant waste streams, such as construction and demolition waste utilised directly on-site, are missing from YLVA database. The data in YLVA consists of manually dialled amounts of waste, so there are dialling errors and mistakes there. Changes in the database and classification codes, among others, may also hinder the comparability of the data.

YLVA provides important data for national monitoring of waste management. However, it is not well suited for local estimations of waste amounts. As the needs for more detailed data on waste amounts and recycling are increasing, YLVA and the utilisation of its data is also being developed.

9.3. Producer responsibility statistics on waste

Description

The Pirkanmaa Centre for Economic Development, Transport and the Environment (Pirkanmaa ELY Centre) collects data on products and waste that are under producer responsibility schemes in Finland. Producer responsibility covers the following products:

- 1) Vehicles
- 2) Batteries and accumulators
- 3) Paper produce
- 4) Packaging
- 5) Tires
- 6) Electrical and electronic equipment

The producer responsibility statistics include data on the amounts of products entering the market as well as the amount and utilisation of the waste entering the producers' waste management systems. (Pirkanmaa Centre for Economic Development, Transport and the Environment, 2019)

As a practical example, the producer responsibility statistics on waste electrical and electronic equipment (WEEE) are presented in detail below. The statistics include monitoring of the amount (mass in tonnes) of WEEE provided to the

domestic markets, collected from households, collected from other sources than households, reused (as a whole or in parts), recycled, incinerated, deposited, treated in Finland, treated in the EU, and treated outside the EU. The data are annually updated and currently available from 2008 to 2018 (Figure A18). The data on WEEE are also separated into a number of product categories: large household appliances, small household appliances, IT and telecommunications appliances, consumer electronics, lighting, light bulbs (excluding incandescent bulbs), electric tools, toys / sports / leisure equipment, health service equipment, surveillance equipment, and automatic dispensers.

VUOSI 2018	Kotimaan markkinoille toimitettu		Kotitalouksilta kerätty		Muilta kuin kotitalouksilta kerätty		Uudelleenkäytetty (kokonaisena)		Uudelleenkäytetty (osina)		Kierrätetty (materiaalina hyödynnetty)		Energiana hyödynnetty		Loppusijoitettu (esim. kaatopaikka)		Käsittely Suomessa		Käsittely EU:ssa		Käsittely EU:n ulkopuolella		
	t	t	t	t	t	t	t	t	t	t	t	t	t	t	t	t	t	t	t	t	t	t	
Suuret kodinkoneet (1)	73 557	34 627	2 140	217	0	31 783	2 568	2 199	34 584	2 183	0												
Pienet kodinkoneet (2)	8 377	2 823	57	45	0	2 644	80	112	2 855	26	0												
Tieto- ja teletekniset laitteet (3)	15 505	4 668	5 533	1 511	47	8 097	88	463	8 993	1 161	52												
Kuluttajaelektronikka (4)	10 145	11 461	1 107	160	0	11 474	296	640	12 463	107	0												
Valaistuslaitteet (5)	8 730	821	27	45	1	739	19	43	845	2	0												
Lamput * (5a)	1 232	997	31	0	0	925	60	43	1 028	0	0												
Sähkö- ja elektroniikkatyökälyt (6)	8 614	796	14	3	1	761	22	23	804	5	0												
Lelut, vapaa-ajan- ja urheiluvälineet (7)	1 339	299	2	5	0	272	10	14	298	3	0												
Terv.huollon laitteet ja tarvikkeet (8)	1 026	78	160	0	0	212	3	22	231	7	0												
Tarkkailu- ja valvontalaitteet (9)	3 602	54	34	0	0	77	4	6	86	2	0												
Automaatit (10)	703	0	951	67	0	737	113	34	941	10	0												
Yhteensä	132 829	56 624	10 056	2 053	49	57 720	3 263	3 599	63 127	3 505	52												

Figure A18. An example of a data set on waste electrical and electronic equipment (WEEE) (Pirkanmaa Centre for Economic Development, Transport and the Environment, 2019).

Sources of data

The Pirkanmaa Centre for Economic Development, Transport and the Environment is responsible for the collection of the data from producers and producer organisations.

Data set properties

The data sets present national data excluding the province of Åland. The data sets are annually updated with a delay of approximately one year. The length of the time series depends on the product type. Monitoring of paper, packaging, and tires has been carried out since the mid-1990s. However, the data series currently available online are shown in Figure A6

Table A6. The data series available in the producer responsibility statistics online (Pirkanmaa Centre for Economic Development, Transport and the Environment, 2019).

Product Type	Time Series	Other
Vehicles	2005–2019	Change in statistics after 2007
Batteries and accumulators	2010–2019	Data on recycling rates from 2014.
Paper	2016–2020	
Tires	2007–2020	Change in calculation method in 2013.
Electrical and electronic equipment	2008–2019	Change in statistics after 2018.
Packaging	2003–2019	Data on recycling rates from 2012.

The data are presented in pdf format available on the website. The data are also used in national statistics.

Data access

The data sets are available for everyone free of charge via the public website of the Finnish environmental administration: https://www.ymparisto.fi/fi-FI/Kartat_ja_tilastot/Jatetilastot/Tuottajavastuun_tilastot (in Finnish). The more detailed data on the producer responsibility schemes is not publicly available.

Technologies

The producer responsibility statistics are utilised in the official national statistics on waste.

Future developments

The collection and publication of these data sets is noted in waste legislation. The collection is thus expected to be continued, and possibly even become more detailed, similarly to other waste-related monitoring in the EU.

Gaps and opportunities

The data on the products and waste under producer responsibility are not entirely complete, since not all the materials enter the producers' systems. In addition, Åland is not included in the national producer responsibility statistics.

9.4. Monitoring of the National Waste Plan

Description

The Finnish Environment Institute SYKE collects quantitative indicators annually for the monitoring of the National Waste Plan. The monitoring covers all the key topic areas in the National Waste Plan: municipal solid waste, construction waste, WEEE, and biodegradable waste. In addition to these, the monitoring includes indicators on general development in the waste sector in Finland, such as the total amount of waste by sector, the amount of hazardous waste, imports and exports of waste, the development of prices in waste transport, and employment and value added in the environmental business sector. (Finnish Environment Institute SYKE, 2021)

Sources of data

The indicators are based on waste statistics and data from Statistics Finland, as well as producer responsibility statistics from the Pirkanmaa ELY Centre.

Data set properties

A graphical summary of the monitoring is available, as well as Excel spreadsheets for all the indicators.

Data access

The indicator data, as well as summaries of the results, are openly available online free of charge via: https://www.ymparisto.fi/fi-fi/kulutus_ja_tuotanto/jatteet_ja_jatehuolto/jatesuunnittelu/valtakunnallisen_jatesuunnitelman_seuranta.

Future developments

The monitoring of the National Waste Plan is compulsory. However, as the plan is renewed at regular intervals, there may also be changes to the indicators.

Gaps and opportunities

As has been stated above while discussing other sources of waste-related data, there is an increasing need for more detailed data on waste, recycling, and reuse in the transition to a circular economy. Monitoring of the National Waste Plan aims to provide information to support better regulation. This would benefit from more detailed data on the individual measures taken into action.

Appendix B. Descriptions of the data sources

[Link to the table](#)

Title	Handbook for a Data-Driven Circular Economy in Finland Data Sources, Tools, and Governance for Circular Design
Author(s)	Tommi Kauppila (ed.) + 33 other authors
Abstract	<p>The use of raw materials is undergoing a major transformation as living standards rise globally and societies move towards digitalisation and renewable energy production. At the same time, there is a growing awareness of the limits of the carrying capacity of our planet. Raw materials and energy must be used and produced efficiently, economically, and renewably so that we can succeed in the long term. The principles of the circular economy can help to meet this challenge.</p> <p>The circular economy is a technical and economic model that seeks to eliminate waste, reduce the use of matter and energy, keep products and materials in use, and enable natural systems to regenerate in an environmentally, socially, economically, and energetically sustainable way. Circularity is best achieved when it is considered at an early stage in the design of products and processes.</p> <p>High-quality and up-to-date data is needed as a basis for design-based circular economy solutions. It can be used to develop new circular economy solutions, identify opportunities for circular economy innovations, and assess their feasibility and profitability. Easy-to-find and easy-to-use open data therefore offers many opportunities to promote the circular economy in practice. It is no wonder that, in addition to economic interests, there are numerous administrative drivers in Finland and Europe that seek to promote a circular economy, digitalisation, and data transparency.</p> <p>In addition to a change in mindset and data, methods for collecting, managing, sharing, and processing data for decision-making purposes have evolved tremendously. Digital data platforms and new technologies for data analysis, networking, and secure sharing also open many new opportunities for the circular economy. At the same time, digital devices and sensors are producing more and more data for a wide variety of things. This data can be collected, systematized, processed, and shared to generate new information and added value.</p> <p>Design-based solutions for the circular economy (CircDNet) is a project funded by the Academy of Finland and run by VTT, GTK, Luke, SYKE, and Aalto University. The project aims to meet the challenge of a data-enabled and design-based circular economy. This report lays the foundation for the project's work to create data and system-level understanding of data and to turn understanding into action towards concrete solutions for the circular economy. The report is aimed at developers of innovations and solutions in the circular economy, decision-makers influencing the conditions for success of the circular economy, and those working with the data on which circular economy solutions are based. The report systematically discusses the data available in Finland as a basis for circular economy solutions, describes the technologies used to collect, manage, distribute, and analyze data to support decision-making, and addresses the governance drivers affecting the development of the digital circular economy.</p>
ISBN, ISSN, URN	ISBN 978-951-38-8764-3 ISSN-L 2242-1211 ISSN 2242-122X (Online) DOI: 10.32040/2242-122X.2022.T401
Date	February 2022
Language	English, Finnish abstract
Pages	135 p. + app. 123 p.
Name of the project	Circular Design Network
Commissioned by	Academy of Finland
Keywords	circular design, open data, twin transition, digital technologies, change drivers
Publisher	VTT Technical Research Centre of Finland Ltd P.O. Box 1000, FI-02044 VTT, Finland, Tel. 020 722 111, https://www.vttresearch.com

Nimeke	Datapohjaisen kiertotalouden käsikirja Datalähteet, työkalut ja hallintokehitys suunnittelulähtöisten kiertotalousratkaisujen tekemiseksi
Tekijä(t)	Tommi Kauppila (toim.) + 33 muuta kirjoittajaa
Tiivistelmä	<p>Raaka-aineiden käyttö on voimakkaassa murroksessa elintason noustessa maailmanlaajuisesti ja yhteiskuntien siirtyessä digitaalisuuteen ja uusiutuvan energian tuotantoon. Samaan aikaan planeettamme kantokyvyn rajat tiedostetaan entistä selvemmin. Raaka-aineita ja energiaa tulee käyttää ja tuottaa tehokkaasti, säästävää ja uusiutuvasti, jotta voimme onnistua pitkällä aikavälillä. Tähän haasteeseen voidaan osaltaan vastata kiertotalouden periaatteiden avulla. Kiertotalous on tekninen ja taloudellinen malli, joka pyrkii pääsemään eroon jätteiden syntymisestä, vähentämään aineen ja energian käyttöä, pitämään tuotteet ja materiaalit käytössä ja mahdollistamaan luonnon järjestelmien uusiutumisen tavalla, joka on ympäristöllisesti, yhteiskunnallisesti, taloudellisesti ja energieteettisesti kestävä. Kiertotalouteen siirtyminen onnistuu parhaiten, kun se otetaan huomioon jo tuotteiden ja prosessin varhaisessa suunnitteluvaiheessa.</p> <p>Suunnittelulähtöisten kiertotalousratkaisujen perustaksi tarvitaan laadukasta ja ajan tasalla olevaa dataa. Sen avulla voidaan kehittää uusia kiertotalouden ratkaisuja, tunnistaa mahdollisuuksia kiertotalousinnovaatioille ja arvioida niiden toteutettavuutta ja kannattavuutta. Helposti löydettävä ja hyödynnettävä avoimesti jaettava data tarjoaa tämän vuoksi paljon mahdollisuuksia kiertotalouden edistämiseen käytännössä. Ei olekaan ihme, että taloudellisten intressien lisäksi Suomessa ja Euroopassa on tunnistettavissa lukuisia hallinnollisia ajureita, jotka pyrkivät edistämään kiertotaloutta, digitaalisuutta ja datan avoimuutta.</p> <p>Ajattelutavan muutoksen ja datan lisäksi myös menetelmät datan keräämiseksi, hallinnoimiseksi, jakamiseksi ja jalostamiseksi päätöksenteon tarpeisiin ovat kehittyneet huimaavasti. Digitaaliset data-alustat sekä uudet datan analysoinnin, verkottamisen ja turvallisen jakamisen teknologiat avaavat paljon uusia mahdollisuuksia myös kiertotaloudelle. Samaan aikaan digitaaliset laitteet ja sensorit tuottavat entistä enemmän dataa mitä moninlaisimmista asioista. Tätä dataa voidaan kerätä, systematisoida, käsitellä ja jakaa uuden informaation ja lisäarvon tuottamiseksi. Kiertotalouden suunnittelulähtöiset ratkaisut (CircDNet) on Suomen Akatemian rahoittama VTT:n, GTK:n, Luken, SYKE:n ja Aalto yliopiston projekti, joka pyrkii vastaamaan datapohjaisen ja suunnittelulähtöisen kiertotalouden haasteeseen. Tämä CircDNet-raportti luo perustaa projektin työlle, jossa datasta pyritään luomaan tietoa ja systeemiton ymmärrystä sekä muuttamaan ymmärrys toiminnaksi kohti kiertotalouden konkreettisia ratkaisuja. Raportti on suunnattu kiertotalouden innovaatioiden ja ratkaisujen kehittäjille, kiertotalouden onnistumisedellytyksiin vaikuttaville päätöksentekijöille sekä kiertotalousratkaisujen pohjana olevan datan kanssa työskenteleville. Raportissa käsitellään systemaattisesti kiertotalousratkaisujen pohjaksi tarjolla olevia aineistoja Suomessa, kuvataan teknologioita, joilla aineistoja kerätään, hallinnoidaan, jaellaan ja analysoidaan päätöksenteon tueksi, sekä pureudutaan digitaalisen kiertotalouden kehittämiseen vaikuttaviin hallinnollisiin ajureihin ja virtauksiin.</p>
ISBN, ISSN, URN	ISBN 978-951-38-8764-3 ISSN-L 2242-1211 ISSN 2242-122X (Verkkojulkaisu) DOI: 10.32040/2242-122X.2022.T401
Julkaisuaika	Helmikuu 2022
Kieli	Englanti, suomenkielinen tiivistelmä
Sivumäärä	135 s. + liitt. 123 s.
Projektin nimi	Circular Design Network
Rahoittajat	Suomen Akatemia
Avainsanat	suunnittelulähtöinen kiertotalous, avoin data, vihreä ja digitaalinen siirtymä, digitaaliset teknologiat, muutosajurit
Julkaisija	Teknologian tutkimuskeskus VTT Oy PL 1000, 02044 VTT, puh. 020 722 111, https://www.vtt.fi/

Handbook for a Data-Driven Circular Economy in Finland

Data Sources, Tools, and Governance for Circular Design



Circular Design Network

ISBN 978-951-38-8764-3
ISSN-L 2242-1211
ISSN 2242-122X (Online)
DOI: 10.32040/2242-122X.2022.T401

VTT beyond the obvious