

Heikki Kumpulainen, Terttu Peltonen,
Ulla Koponen, Mikael Bergelin,
Matti Valkiainen & Mikael Wasberg

In situ voltammetric characterization of PEM fuel cell catalyst layers

In situ voltammetric characterization of PEM fuel cell catalyst layers

Heikki Kumpulainen*, Terttu Peltonen*, Ulla Koponen**,
Mikael Bergelin**, Matti Valkiainen*, Mikael Wasberg***

* VTT Processes

** Åbo Akademi, Process Chemistry Group

***Kemira Chemicals Oy, Oulu Research Center

ISBN 951-38-5887-1 (nid.)
ISSN 1235-0605 (nid.)

ISBN 951-38-5888-X (URL: <http://www.inf.vtt.fi/pdf/>)
ISSN 1455-0865 (URL: <http://www.inf.vtt.fi/pdf/>)

Copyright © VTT 2002

JULKAISIJA – UTGIVARE – PUBLISHER

VTT, Vuorimiehentie 5, PL 2000, 02044 VTT
puh. vaihde (09) 4561, faksi (09) 456 4374

VTT, Bergsmansvägen 5, PB 2000, 02044 VTT
tel. växel (09) 4561, fax (09) 456 4374

VTT Technical Research Centre of Finland, Vuorimiehentie 5, P.O.Box 2000, FIN-02044 VTT, Finland
phone internat. + 358 9 4561, fax + 358 9 456 4374

VTT Prosessit, Otakaari 3 A, PL 1404, 02044 VTT
puh. vaihde (09) 4561, faksi (09) 456 6390

VTT Processer, Otsvängen 3 A, PB 1404, 02044 VTT
tel. växel (09) 4561, fax (09) 456 6390

VTT Processes, Otakaari 3 A, P.O.Box 1404, FIN-02044 VTT, Finland
phone internat. + 358 9 4561, fax + 358 9 456 6390

Technical editing Leena Ukaskoski

Otamedia Oy, Espoo 2002

Kumpulainen, Heikki, Peltonen, Terttu, Koponen, Ulla, Bergelin, Mikael, Valkiainen, Matti & Wasberg, Mikael. In situ voltammetric characterization of PEM fuel cell catalyst layers. Espoo 2002. VTT Tiedotteita – Research Notes 2137. 28 p. + app. 4 p.

Keywords fuel cells, PEMFC, catalysts, layers, membrane electrodes, characteristics, measurement, electric current, voltage, cyclic voltammetry

Abstract

In our work we have studied in-house made MEA:s (geometric area 5 cm²) based on commercial (E-TEK, Inc.) carbon supported Pt and Pt/Ru catalysts. A Nafion 115 membrane was coated with ink containing Pt/C catalyst and Nafion solution and dried layers were sintered by hot pressing. After post-processing the membranes were installed in a single cell test fixture. In addition, the ink used for coating was characterized in thin film form in sulphuric acid electrolyte and the results were compared to the fuel cell data.

Current-voltage characteristics were measured after a running-in period of about 16 hours. After cooling the test fixture down to room temperature the cyclic voltammograms were taken in situ by using a two-electrode potentiostatic measurement circuit. The electrode under study is purged by an inert gas (N₂) while the other electrode is purged by hydrogen gas so as to form a reversible hydrogen electrode. In this manner the surface processes taking place on both the anode and cathode side of the MEA could be measured and evaluated.

From the hydrogen desorption charge on Pt the available Pt surface area has been determined and the ratio between measured area and calculated total Pt area was in the range of 30%. The ratios between electrochemical surface areas on the anode and cathode side compare well with the corresponding ratios obtained from calculations of total added Pt surface area. The relation between the voltammetrically obtained surface areas and the polarization data (current-voltage curves) is discussed.

An enlargement of the active surface area could be noted after potential scans into the Pt oxide formation region. This indicates the presence of a deactivation process, probably due to adsorbed organic material removed oxidatively during the extended polarization. When MEAs based on Pt/Ru alloy catalysts were measured the hydrogen adsorption charge decreased as a result of the lower hydrogen adsorption capability of Ru. In the double layer region the formation of Ru-oxides was also well manifested.

Preface

This report is based on the work under the research contract “Manufacturing and Optimization of PEM Fuel Cells”, financially supported by the National Technology Agency of Finland (Tekes). The project was co-ordinated by Laboratory of Advanced Energy Systems at Helsinki University of Technology. The work reported here was done at VTT Chemical Technology and Åbo Akademi, Process Chemistry Group.

Contents

Abstract.....	3
Preface	4
1. Introduction.....	7
2. The fuel cell catalyst layers.....	8
3. Measurement of current-voltage characteristics	10
4. Cyclic voltammetry of surface processes	12
5. Characterization of inks by cyclic voltammetry	15
5.1 Characterization of Pure Ink.....	15
5.2 Modification of Ink with Ru.....	16
5.3 Characterization of Pt _{0.7} /Ru _{0.3} /C Catalyst Immobilized on Carbon Fibers	17
6. In-situ characterization of membrane catalyst layers by cyclic voltammetry.....	18
6.1 Measuring procedure	18
6.2 In-situ measurements of catalyst layers.....	21
7. Discussion.....	27
References	28
Appendix	

1. Introduction

The Polymer Electrolyte Membrane Fuel Cell (PEMFC) consists of two electrodes, the anode and the cathode, separated by a polymer membrane electrolyte. Each of the electrodes is coated with a catalyst layer. The electrodes, catalyst and membrane together form the membrane electrode assembly (MEA). Hydrogen and oxygen from the air combine in the fuel cell to produce electricity electrochemically together with the main reaction product: water.

The development of PEMFCs has included innovations to decrease the amount of platinum needed. One possibility is to use carbon supported platinum to increase the effective surface area of the catalyst. The method originates from Los Alamos National Laboratory [e.g. Wilson & Gottesfeld 1992]. In the method developed the catalyst layer was formed spreading a slurry of soluted ionomer and carbon supported platinum on the membrane. The result is a porous layer consisting of catalyst and the ionomer on the membrane. In the work reported here the above mentioned method was used.

To study the performance of catalyzed membrane electrode assemblies for PEM fuel cells, a single cell is typically used. A single fuel cell consists of a membrane electrode assembly and two flow field plates. The fuel cell is connected to a test station, which generates polarization curves indicating the total functioning of the MEA. In order to obtain more specific information an electrochemical method to characterize catalyst layer was taken into use.

Cyclic voltammetry is a well-known electroanalytical method, which is based on linear voltage sweep between two fixed values. In this work it is applied to measure catalyst electroactive surface area. The aim was to use both dried slurry (ink) and in-situ cyclic voltammetry in characterizing fuel cell catalyst layer. These results include the first experiences using the built-up cyclic voltammetry measuring arrangement.

2. The fuel cell catalyst layers

The polymer electrolyte fuel cell membranes studied here are prepared in house by spraying ink consisting of soluble Nafion[®] and Pt/C catalyst powder (ETek 20% Pt on Vulcan XC-72R with an average Pt particle size of 2.5 nm and a 112 m²/g Pt surface area) on Nafion surface, both sides, see Appendix 1 for details. Figures 1 and 2 show the Scanning Electron Microscopy photographs of typical cross-section and a lateral view of the catalyst surface on Nafion.

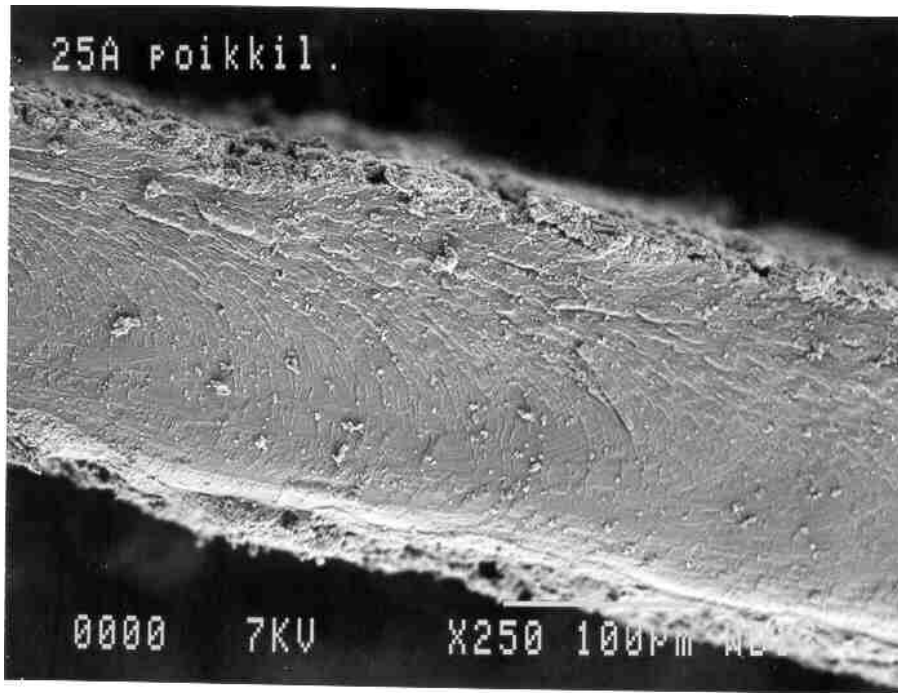

Figure 1. Cross-section of a proton exchange membrane with catalyst layers on both sides.

The layer consists of Pt/C-particles held together with Nafion ionomer, which forms a proton-conducting pathway from anode to cathode side. The porosity of the layer facilitates movement of reacting gases to the active sites.

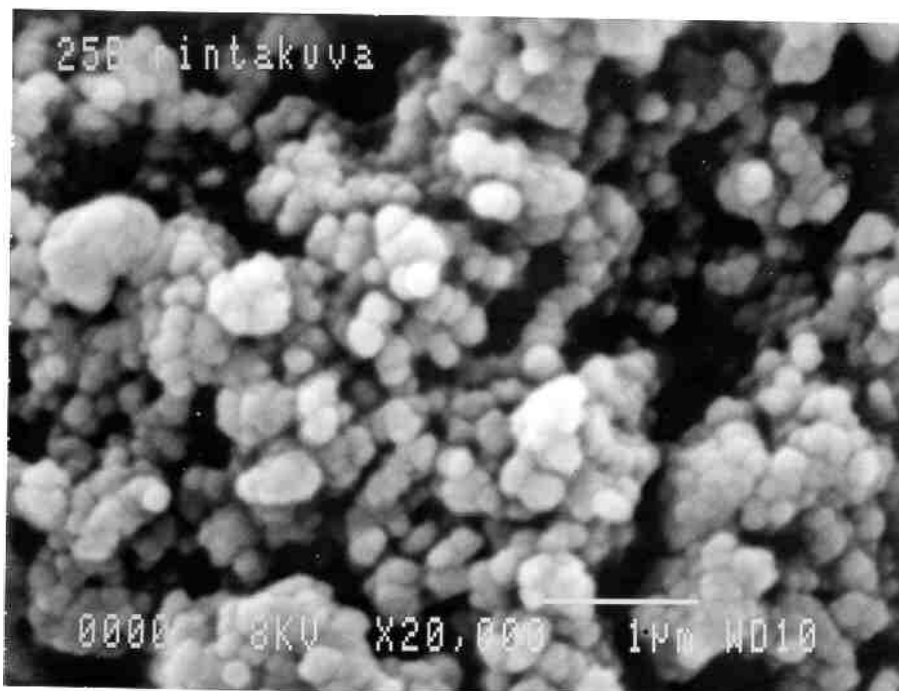

Figure 2. Lateral view of a Pt/C catalyst layer on a Nafion membrane. Agglomerates of Pt/C and the porous structure of the layer are visible.

3. Measurement of current-voltage characteristics

The current-voltage characteristics of the fuel cell MEAs were measured using an H₂/air unit cell (5 cm² active area, Globe Tech. Inc.). The unit cell consists of two graphite plates, which are held together by end plates made of gold plated copper. The MEA is installed between the plates, which have engraved gas channels in contact with carbon cloth serving as pathway of reacting gases and electrons to the electrochemically active area of the MEA. The principle of a unit cell assembly is shown in Figure 3.

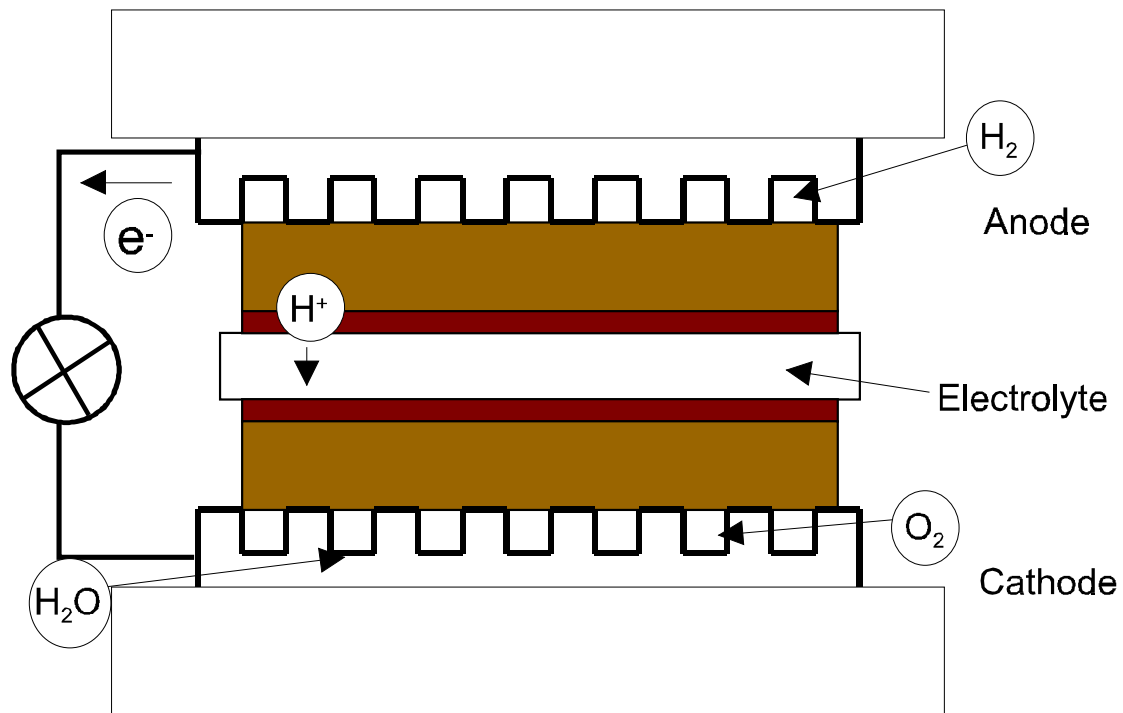

Figure 3. Principle of a PEM unit cell assembly showing schematically the different components.

Experimental measurements were carried out at 60 °C and in gas pressure 1/1, absolute bar for anode/cathode side). The fuel cell test station (GlobeTech GT-100) is equipped with a humidifying system of the reactant gases and temperature control of the cell. The humidifying temperature for H₂/air was maintained at 75 anode/65 cathode °C. A flow configuration was used with gas fluxes of 2 times the stoichiometric value for both H₂ and air. The gas flow rates were controlled by electronic mass flow controllers in the fuel cell test station. The cell potential against current density measurements were recorded in a computer interfaced with the fuel cell test station.

Current-voltage (I-U) characteristics were measured after a running-in period of about 16 hours. Figure 4 shows current-voltage characteristics of measurements, where resistive components in the cell are compensated.

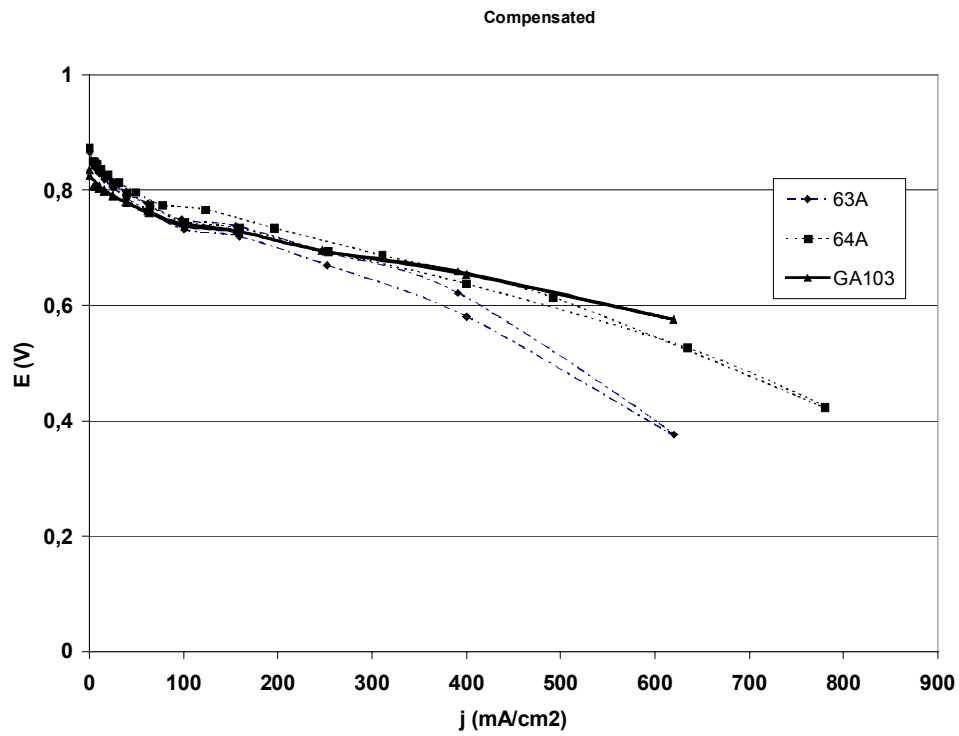

Figure 4. Current-voltage characteristics of measurements, where resistive components in the cell are compensated. Samples 63A and 64A are in-house fabricated, sample GA103 is commercially obtained.

4. Cyclic voltammetry of surface processes

The cyclic voltammetry technique is one of the most commonly used electroanalytical techniques for the study of electroactive species and electrode surfaces.

The potential of the WE is scanned linearly from an initial value to a predetermined potential limit, E_{\max} , where the direction of the scan is reversed. The potential is then scanned to the lower potential limit, E_{\min} , where the scan is again reversed. The current response as a result of this polarization is then plotted as a function of the applied potential. This current-voltage curve is referred to as the cyclic voltammogram and it gives information about reactions occurring on the WE surface. These can for instance be compounds added to the electrolyte being oxidized or reduced at the WE surface. Other information possible to obtain is knowledge of the surface structure sensitive processes occurring with the surface atoms of the WE and electrolyte, for instance creation of a surface oxide or reduction of this oxide, or in the case of catalytically active metals also the adsorption of a hydrogen layer and removal (desorption) of this layer.

If the rate of the electron transfer at the electrode surface is rapid enough for the species adjust to the ratio defined by the Nernst equation both the reduction transient obtained when sweeping the potential towards more negative and the corresponding oxidation transient when sweeping the potential positive have their maximum i value at the same potential. The current response from hydrogen adsorption (reduction) and desorption (oxidation) on platina is an example of such a reaction (see Figure 5, E and G).

If on the other hand the process taking place on the electrode is controlled both by the rate of electrode reaction and by the rate of diffusion the potentials of the reduction and oxidation transients shift further and further apart when increasing sweep rate. As the contribution from the rate of diffusion has further diminished and the electrode process is controlled only by the rate of reaction the oxidation and reduction transients become completely separated. An example on such an irreversible reaction is the oxidation and reduction of the platina surface (see Figure 5, B and D).

When investigating surface reactions using cyclic voltammetry one must also take into account that apart from information about the change of state of the surface one also detects a contribution from the change of state of the double layer at the electrode-electrolyte interface. The effect of this non-Faradaic contribution due to the charging up of the double layer on the total charge is dependent on the potential sweep rate. At low sweep rates the capacitive (non-Faradaic) charge contribution is large in comparison to the charge due to the surface processes but is relatively small at for instance 50 mV/s. In the Pt CV this capacitive contribution correction can be calculated from the double layer

current (between 0.35 and 0.75 V). When the number of electrons involved in the process are known the amount of atoms attached to (or removed from) the surface can be calculated from the corrected charge. The charge obtained when desorbing a complete hydrogen layer (G in Figure 5) also gives information about the real surface area of the WE since it is assumed that one hydrogen atom occupies one Pt site and the number of Pt atoms/cm² can be calculated for the different surface types from crystal structure data. In the case of polycrystalline Pt a charge of 200 μC cm⁻² is assumed (average of the three basal surfaces).

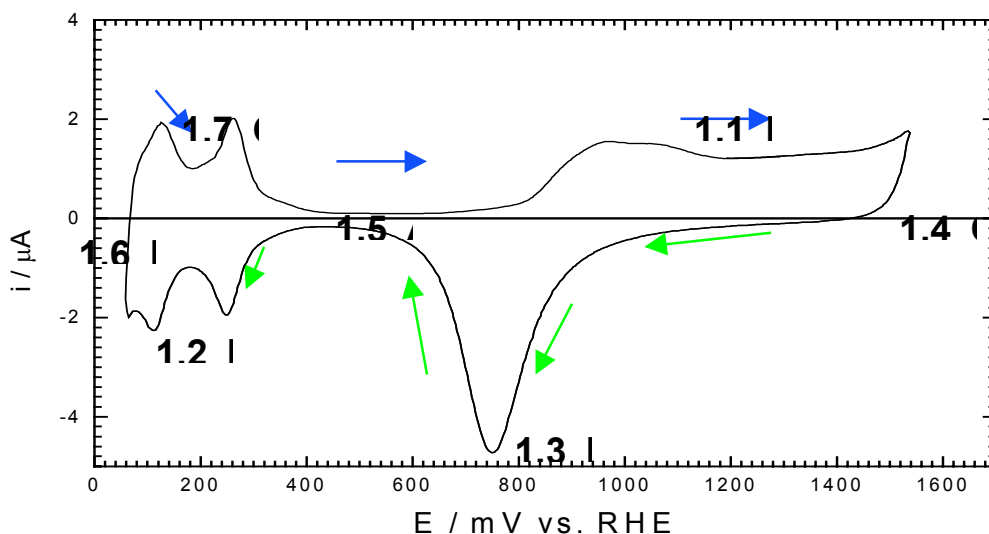
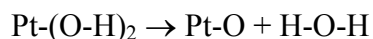
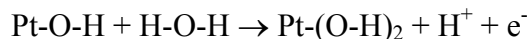
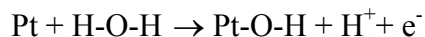
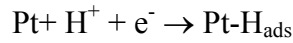

Figure 5. Cyclic voltammogram of polycrystalline platinum. The main reactions occurring on the surface are divided into sections indicated with the letters A through G.

The different surface processes visible in a pc Pt CV in 0.5 M H₂SO₄ are shown in Figure 5. When starting a positive potential sweep at point A no current is flowing in the system (apart from some capacitive current as a result of the charging up of the double layer). When reaching section B at approx. 800 mV a Pt surface oxide is being created for instance as follows



If the potential would be swept above 1.55 V oxygen gas formation would start and therefore the direction of the potential sweep is reversed at point C. No current is flowing before section D where the surface oxide created during the positive going sweep is being reduced in the opposite reactions of those presented above. At section E a hydrogen layer is being adsorbed on the surface in two clearly separated processes as follows



However, these peak shaped processes should be separated as hydrogen is first adsorbing at a higher potential ($E_{\text{peak}} \approx 275 \text{ mV}$) onto the [100] sites and then at a lower potential ($E_{\text{peak}} \approx 125 \text{ mV}$) onto the [110] sites during the negative potential scan as

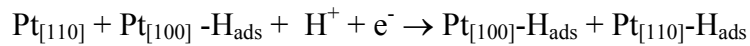
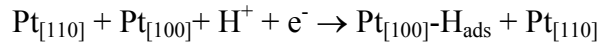

This interpretation is based on CV results obtained on [100] and [110] single crystal surfaces where the hydrogen adsorption and desorption peak potentials correspond well with the peak potentials of the two separate processes visible in the polycrystalline Pt CV. Therefore a full hydrogen layer is not created until at point F where the second process is completed. The potential sweep direction is then again changed to avoid the hydrogen gas evolution resulting from a more negative potential than that required to complete the hydrogen layer. Sweeping the potential again in a positive direction from point F this hydrogen layer is then desorbed in two steps in section G with the opposite reactions to the ones presented above.

5. Characterization of inks by cyclic voltammetry

5.1 Characterization of Pure Ink

A fuel cell catalyst ink based on Vulcan XC-72 / Pt (30%) and Nafion has been characterized by cyclic voltammetry by means of an impinging jet flow cell (Bergelin & Wasberg 1998). The ink was deposited onto a gold substrate by spin-coating (in order to obtain a uniform thin film), followed by drying of the ink under an IR-lamp. The properties of this ink film were then characterized in 0.5 M H_2SO_4 by cycles between

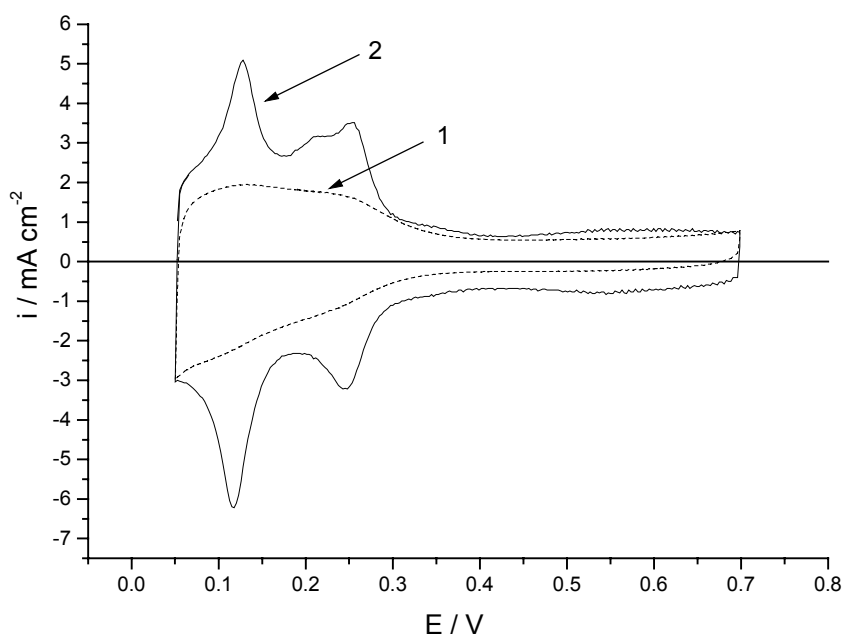

Figure 6. Basic voltammetry of a thin ink film in 0.5 M H_2SO_4 . (1) Before cleansing with CO. (2) After CO dosing and stripping. Scan rate: $0.05 V s^{-1}$.

0.05 and 0.7 V (vs RHE) as depicted in Figure 6 (curve 1). As seen the hydrogen peaks of the Pt crystallites are not well defined. After expelling impurities present in the ink by dosing a strongly adsorbing compound, CO, onto the ink and removing it (oxidizing it away) in pure electrolyte a well-defined hydrogen region was obtained (curve 2). The response from the Pt(110) and Pt(100) surfaces, peaks at 0.12 V and 0.25 V, is clearly visible and resembles that of a polycrystalline Pt electrode.

5.2 Modification of Ink with Ru

After the characterization step the thin film ink was modified with different sized doses of 10^{-4} M Ru by electroreduction at 0.1 V. In Figure 7 examples of the change in voltammetry after dosing of a small amount (10 s) and a larger amount (180 s) can be seen. It should be noted that the overall behavior is remarkably similar to that of polycrystalline Pt subjected to corresponding modifications. As can be seen from the picture both (all three) hydrogen peaks are affected by the doses indicating that Ru has been relatively uniformly deposited on all surface types of the Pt nanoparticles.

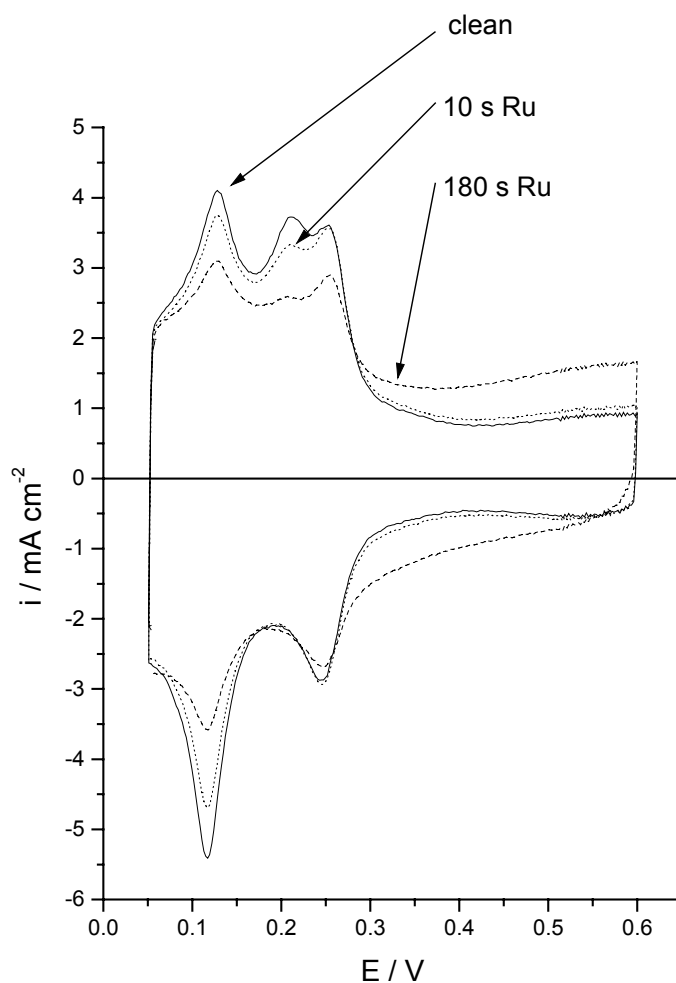

Figure 7. Effect of Ru modification on the ink base voltammetry.

The clear increase in double layer current response indicates a similar surface oxide formation as in the case of polycrystalline Pt. However, it should be noted that part of the Ru could be present in the Nafion matrix or directly deposited onto the carbon particles. This would mean that only part of the Ru is actually modifying the Pt surface

whilst the remaining Ru is acting as independent Ru “nanoparticles”. Judging by the decrease in the hydrogen region charge compared to the charge due to oxidation of Ru (visible between 0.3 and 0.6 V) it is very clear that this is the case since the ratio is much smaller than for similar amounts of Ru deposited onto Pt bead electrodes. Nevertheless, these measurements can be used in assessment of for instance catalysts used for direct methanol oxidation, since methanol is not adsorbed on Ru alone.

5.3 Characterization of Pt_{0.7}/Ru_{0.3}/C Catalyst Immobilized on Carbon Fibers

Pt/Ru carbon powder was immobilized onto a 1.5 mm thread made out of carbon fibers. The thread was then repeatedly immersed in ultra pure water to remove any loosely bonded catalyst particles. After this the thread was moved to a standard electrochemical cell containing 0.5 M H₂SO₄ and a cyclic voltammogram was recorded between 0.05 and 0.7 V. The resulting voltammogram can be seen in Figure 8. Due to the poor resolution of the hydrogen desorption processes the particles were cleaned by potential sweeps between 0.05 and 1.6 V. This treatment revealed a more detailed hydrogen region but the overall charge decreased significantly. This decrease could be attributed partly to the oxidation and removal of parts of the surface Ru (Ru is desorbed above 1.1 V) but the main decrease was most likely due to the detachment of parts of the catalyst particles when swept to oxygen evolution edge (1.6 V).

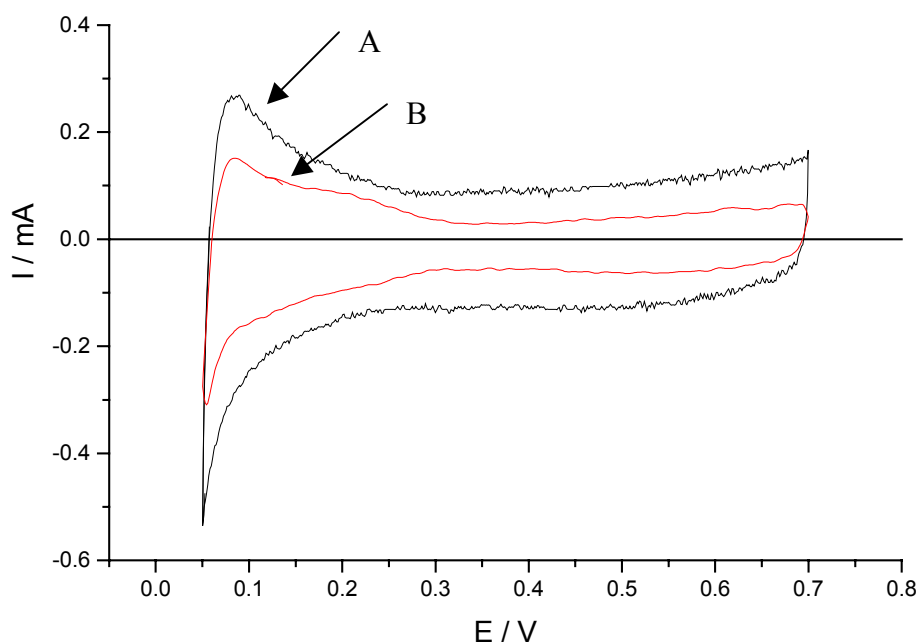

Figure 8. Basic voltammetry of a Pt_{0.7}/Ru_{0.3} catalyst supported on carbon fibers. (A) before (B) after potential excursions up to 1.6 V.

6. In-situ characterization of membrane catalyst layers by cyclic voltammetry

6.1 Measuring procedure

In situ cyclic voltammetry was performed between current-voltage measurements using the same unit cell test fixture. The measurement is based on two electrodes arrangement (Cheng et al. 1999). One of the electrodes was flushed with hydrogen gas (H_2 5.0) and it acted as a reference electrode and the other one flushed with nitrogen gas (N_2 6.0) acted as a measuring electrode, Figure 9. The gases were humidified at an atmospheric pressure in gas washing bottles with fine sinters placed in a water bath and piped to the electrodes via the gas channels of the graphite plates.

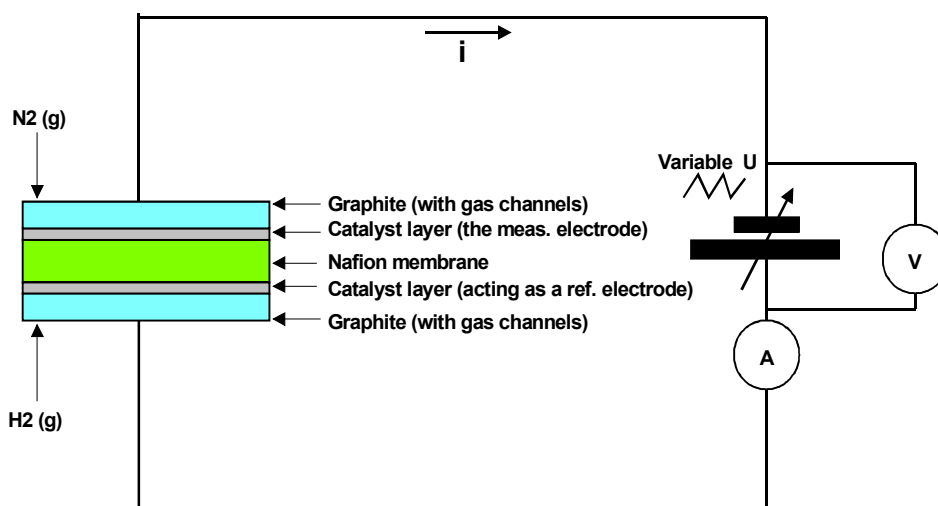

Figure 9. In situ cyclic voltammetry of a unit cell schematically.

In order to be able to obtain reproducible and meaningful measuring results most significant variables were identified. The adopted measuring procedure was based on an experience from a series of measurements. In the present arrangement the voltammetric cycle was deformed at elevated temperatures possibly due to insufficient humidifying of the feeding gases. The higher the temperature, the more resistive features of the voltammogrammic cycle were observed. Figure 10 shows an example of these curves.

Figure 11 shows measured charge as a function of gas flow and humidification time keeping both the cell and humidification bottles at room temperature. The measured hydrogen desorption peak charge was increased at first and then reached a saturation value. A 70 min gas flow time for purging and humidification was used prior to beginning the measuring procedure and the measurement was performed about 80 minutes after beginning the gas flows, when the measured charge had already reached

its saturation value, Figure 11. For more effective humidification the temperature of the humidification bottles was kept at 40 °C. In the applied procedure the cell was kept at room temperature for acceptable measuring results.

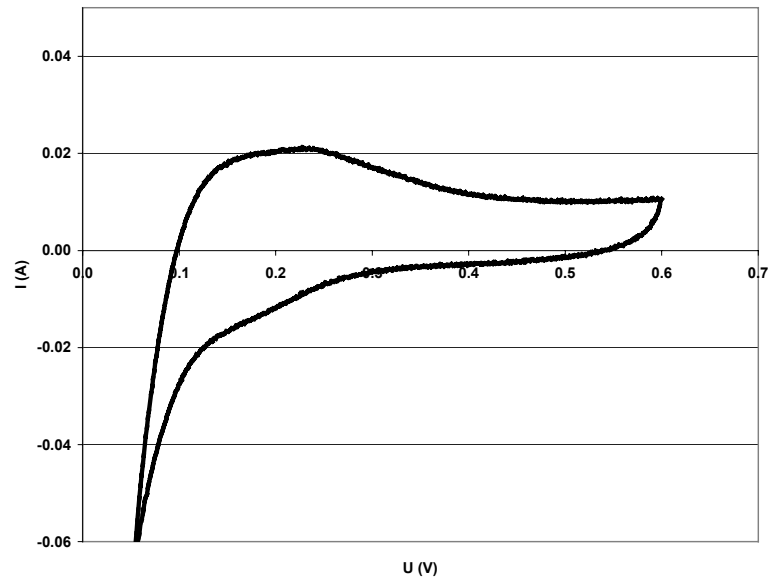

Figure 10. Cyclic voltammogram of MEA 66A at a cell temperature of 50 °C. Sweep rate was 50 mV/s .

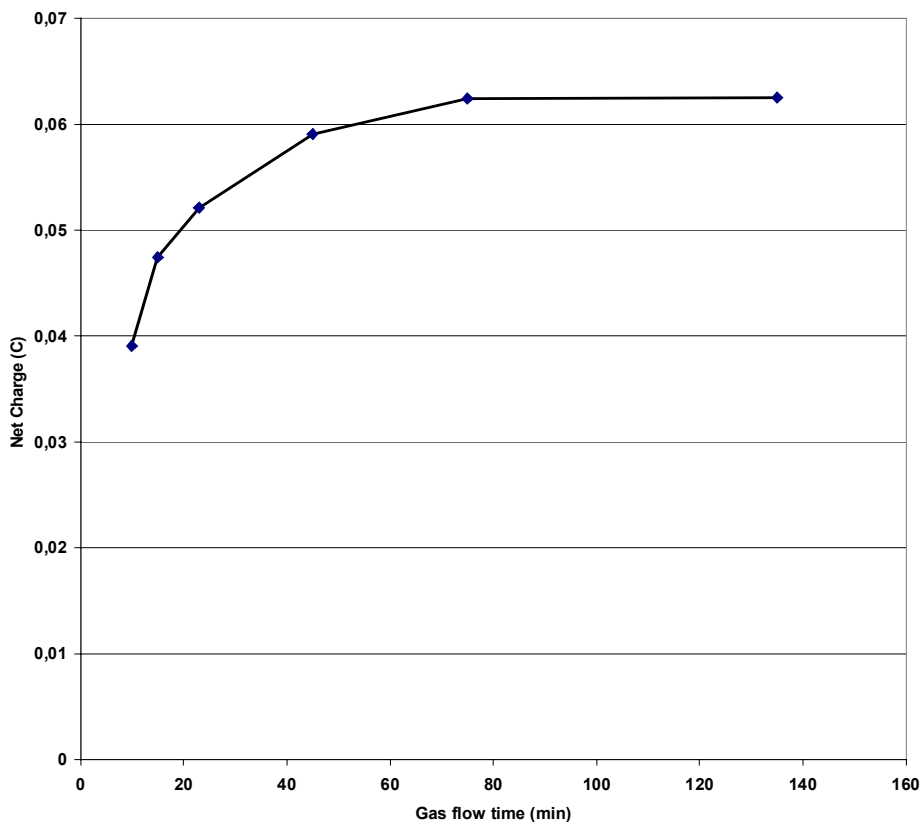

Figure 11. Effect of gas flow and humidification time on the measured charge at room temperature (MEA 66A, 22 °C).

The $I-U$ curve for the cell was run at first. Adding in the associated "awakening" time it took about 16 hours, see above. The test fixture was transferred to the cyclic voltammetry measuring arrangement and was let to cool down to room temperature. In the beginning the gases were purged and then the cyclic voltammograms were taken. For activating and purifying the electroactive Pt surface from possible impurities 5 cycles between the voltages 0.05–1.5 V at a sweep rate of 300 mV/s were run. During these high potential cycles the impurities, which may be adsorbed small organic molecules, were oxidized and removed from the surface. After these cycles the electroactive surface area was seen to be increased. Thereafter measurement cycles (4) between the voltages 0.05–0.6 V were run at the sweep rate of 50 mV/s. The actual measurement was taken from the fourth cycle.

From the saved voltammetric cycle the hydrogen desorption peak charge was obtained as follows. The minimum on the upper branch of the voltammogram was determined indicating the baseline. It occurred approximately at the potential of 0.4 V. Integrating above this baseline gave the net hydrogen desorption charge. Typically integration was performed approximately between the potentials of 0.1 and 0.4 V.

6.2 In-situ measurements of catalyst layers

Similar Pt peaks and structure of the voltammogram were observable in in-situ catalyst layer measurements (Figure 4) as in the thin-layer measurements of the ink shown in Figure 12. Probably due to the thicker layer and longer diffusion distances the Pt crystal plane peaks are not so clearly resolved, however. Also the negative bias of the voltammogram is different from the thin layer ink measurement. The bias was presumably due to trace oxygen in the nitrogen gas originating from the trace oxygen impurity of the nitrogen gas and/or oxygen diffusion through the silicon hose.

In contrast, the commercial MEA gave a voltammogram with a positive bias, Figure 13. Probably the positive bias was due to the diffusion of hydrogen gas through the thin membrane. So tiny a positive bias is negligible in actual power generation applications, but in the sensitive voltammetric measurement its effect shows up easily, however.

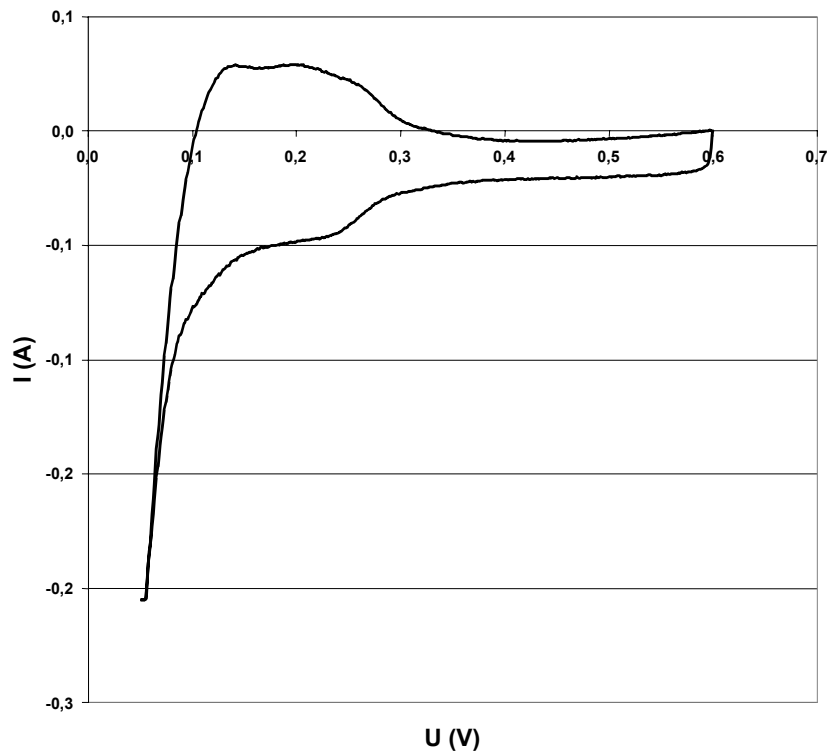

Figure 12. Cyclic voltammogram of MEA 64A (0.32 mg Pt/cm^2). Sweep rate was 50 mV/s .

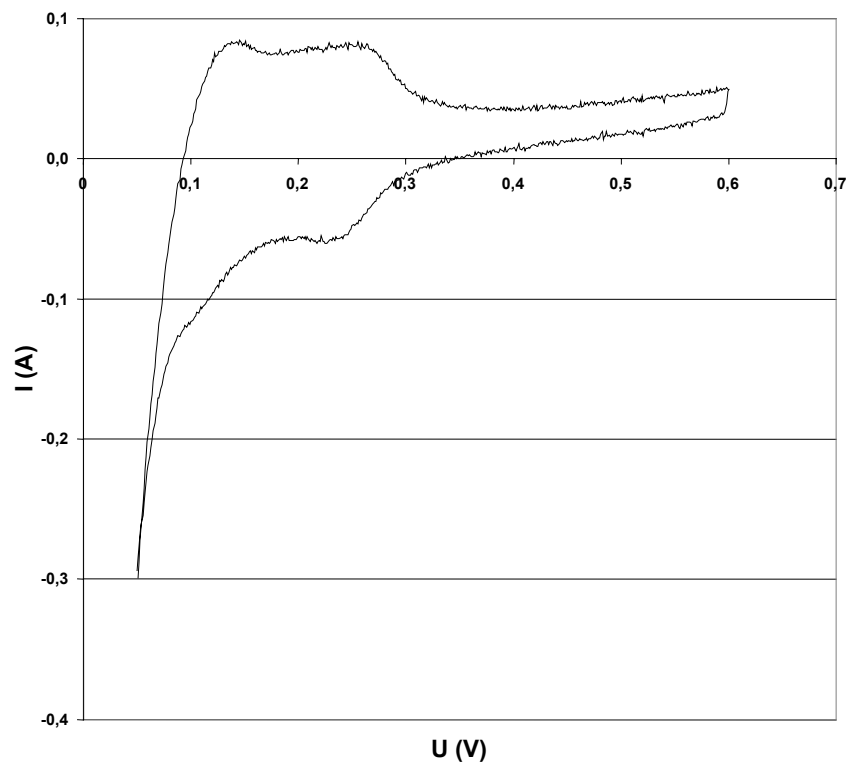

Figure 13. Cyclic voltammogram of MEA GA103 (0.4 mg Pt/cm^2). Sweep rate was 50 mV/s .

Pt/Ru compound catalyst is interesting, because it is more tolerant to trace CO in H₂ than Pt catalyst. Carbon monoxide occurs in a reformer generated hydrogen gas and it is a significant catalyst poison. Unfortunately determination of electroactive Pt/Ru catalyst surface area is more problematic due to indeterminate peaks, Figure 14.

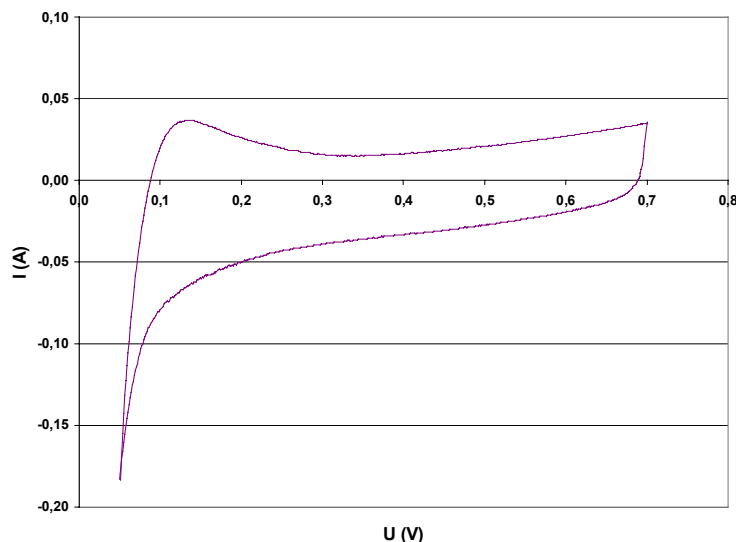

Figure 14. Cyclic voltammogram of a Pt/Ru MEA.: Sweep rate was 50 mv/s. (MEA 68A; Pt: 0.42 mg/cm² + Ru: 0.21 mg/cm²)

Figure 15 shows the behaviour of the hydrogen desorption charge as a function of measurement number. Time from the beginning of the measurement series is displayed in the tiny boxes in the graph. An idea about the reproducibility of the measurement is obtained from the first eleven measurements made during the first 1h time. The calculated relative standard deviation turned out to be 0.8%. The Pt electroactive surface area is proportional to the charge and obtainable by dividing with a factor of 200 $\mu\text{C}/\text{cm}^2$, that is based on the assumption of equal contributions of all three basal planes of Pt. The electroactive surface area decreased about 7% during the first 15h and futhermore about 4% during the next 150h, but not much thereafter, Figure 15. Gas flows were discontinued between measurement periods. Figure 16 shows the charge as a function of time.

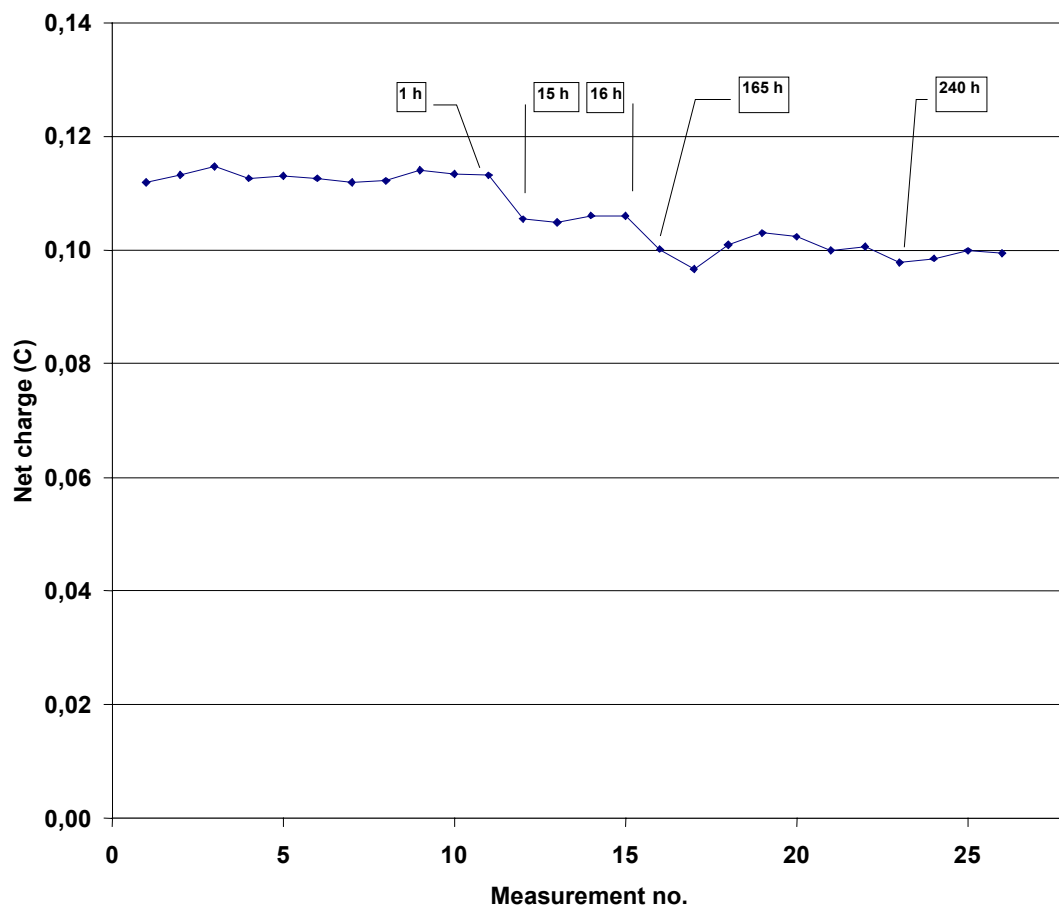

Figure 15. Measured charge as a function of measurement number. Time is shown in the tiny boxes (MEA 64A; 0.32 mg Pt/cm²).

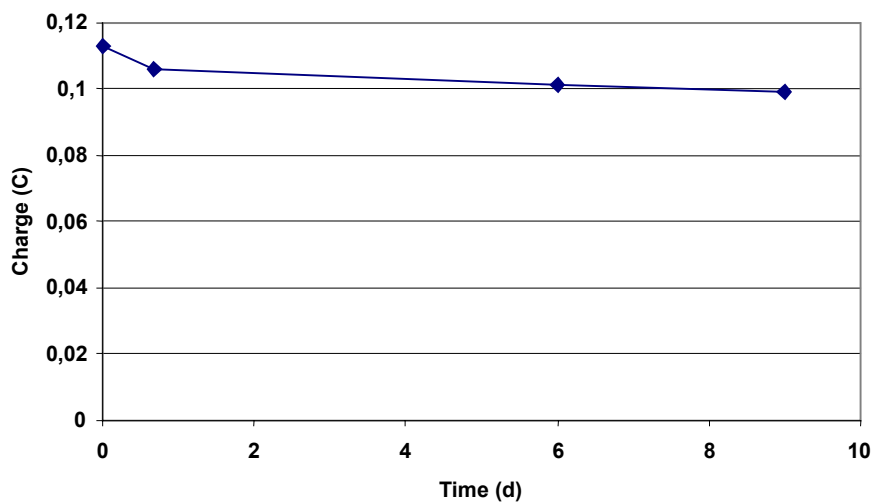

Figure 16. Measured charge as a function of time (MEA 64A).

Measuring results from four in-house prepared MEAs (63A, 64A, 66A and 69A) and a commercial one (code sign GA103 made by GoreTech) are shown in Table 1. The charges per mass unit Pt were calculated from the measured charges and the mass densities. Two observations are evident from the data shown in columns 6 and 7. Although mass densities on both sides of MEAs related up to one to four, the obtained figures were in the same range proving that at these mass densities self-shading effects were absent (i.e. indication of linearity). In the range of 64–83 mC/mgPt they were of the order of the commercial one (81 mC/mgPt).

The last two columns indicate shares of electroactive platinum obtained by comparing the voltammetrically determined surface area with the geometric one. The latter of the two areas was obtained from the mass density and the data of the catalyst ink supplier (Pt specific area 112 m²/g). The specific area has been calculated on the basis of the spherical particle assumption and the particle diameter. On this basis it is evident from the table that on the order of 30% of the Pt in the catalyst layer is electroactive.

For experimenting a MEA was made likewise the other MEAs, but without using TBAOH in the preparation procedure. Although cyclic voltammetry indicated a typical electroactive surface area for the MEA, the polarization measurement showed fundamentally degraded performance.

Table 1. Measured charges (CV) and calculated shares of electroactive Pt.

MEA	Mass density of Pt		Measured charge		Charge/cm ² /(mgPt/cm ²)		Area based on charge/ ("Geometric area")	
	Side I (mg/cm ²)	Side II (mg/cm ²)	Side I (C/cm ²)	Side II (C/cm ²)	Side I (C/mgPt)	Side II (C/mgPt)	Side I (%)	Side II (%)
63A	0.1	0.31	0.008	0.023	0.079	0.074	35	33
64A	0.11	0.32	0.007	0.022	0.064	0.070	29	31
66A	0.17	0.22	0.014	0.083	0.083	0.083	37	
69A	0.08	0.30	0.005	0.020	0.067	0.066	30	29
GA103		0.4		0.032		0.081		

7. Discussion

A method for in situ voltammetric characterization of PEM fuel cell catalyst layers was developed. Similar voltammograms were obtained for the catalyst both in ink and in-situ measurements. The method was used to determine Pt catalyst electroactive surface areas.

In the in-house prepared MEAs coarsely 30% of the Pt in the catalyst layers proved to be electroactive. Pt utilization obtained was of the order of the commercial membrane. Mass density did not significantly affect on the electroactive surface area per mass unit catalyst in the range utilized. I-U curves for the in-house made MEAs showed performance on the order of the commercial one. Pt/Ru mixed catalyst showed a more indeterminate voltammogram than Pt catalyst and was apparently more difficult to quantify.

In-situ voltammograms are useful in assessing catalyst layer electroactive surface areas. In order to obtain comparable results the method has to be performed in an identical way dealing with the measuring method and membrane history. If this is not allowed for, great variability of the results is to be expected.

References

Cheng, X., Yi, B. Y., Han, M., Zhang, J., Qiao, Y. & Yu, J. 1999. Investigation of platinum utilization and morphology in catalyst layer of polymer electrolyte fuel cells. *J. Power Sources* 79, pp. 75–81.

Wilson, M. S. & Gottesfeld, S. 1992. High Performance Catalyzed Membranes of Ultra-low Pt Loadings for Polymer Electrolyte Fuel Cells. *J. Electrochem. Soc.* February, pp. L28–L30. (Vol. 139, No. 2.)

Bergelin, M. & Wasberg, M. 1998. The impinging jet flow method in interfacial electrochemistry: an application to bead-type electrodes. *J. Electroanal. Chem.* 449, pp. 181–191.

Appendix 1. Manufacture of the fuel cell electrodes

The development of PEMFCs has included innovations to decrease the amount of platinum needed. A beneficial alternative possibility is to use carbon supported platinum to increase the effective surface area of the catalyst. The method originates from Los Alamos National Laboratory [e.g. Wilson & Gottesfeld 1992a,b]. In the method invented the catalyst layer was formed spreading a slurry of soluted ionomer and carbon supported platinum on the membrane. The result is a porous layer consisting of catalyst and the ionomer on the membrane. In the work reported here the above mentioned method was used.

Basic method

The membranes were pre-treated as follows: boiled one hour in 5% H₂O₂ to remove organic impurities. After rinsing the membranes were subject to one hour boiling consequently in 0.5 M H₂SO₄, water and 0.5 M NaOH thus activating the ion exchanger and saturating the exchange sites with sodium. The membranes were rinsed and left to stay in water before spreading the catalytic layer on the surfaces.

The ink (Table A1) was fabricated as follows: the Pt/C catalyt was mixed four hours with 5% Nafion solution (in propanol) using ultrasound after which period TetraButylAmmonium Hydroxide (TBAOH) was added to the mixture and mixed several hours to change the ionic form with the organic cation. The ink was conditioned to proper consistency for spreading by adding water and glycerol (Wilson Membrane catalyst layer for fuel cells. US Pat 5,211,984, 1993).

Table A1. Exemplary ink for catalyst layers. The components resting in the dried layer are also shown.

	Ink 10			
	#g in slurry	% in slurry	#g dried	% dried
Pt/C	1,001	3,0 %	1,001	73,7 %
<u>Nafion</u>	6,65	20,0 %	0,3325	24,5 %
<i>Glycerol</i>	20,12	60,5 %	0	0,0 %
<i>Water</i>	5	15,0 %	0	0,0 %
<u>TBAOH</u>	0,477	1,4 %	0,02385	1,8 %
Total	33,248	100,0 %	1,35735	100,0 %

The membrane was installed flat on a porous sinter surface of a box enabling the use of vacuum to hold the membrane in place. Some preparatory wiping procedures were made before spraying of the ink on the surface. The spraying was done with an airbrush (Badger). The next phases consist of drying of the solvents and diluents from the surface and heat-treatment of the layer to sinter the Nafion-coated particles to each other and to the substrate. Subsequently the procedure was performed on the other side of the membrane. An optional heat-treatment under pressure was performed.

The purpose of the NaOH and TBAOH was to decrease the sintering temperature of Nafion. The cations had to be removed before use and this was done in boiling the MEAs in 0.5 M H₂SO₄. The MEAs were after the treatment ready for use.

Methods for serial production

The basic method is suitable only for fabrication of MEAs in a small scale caused by the relatively slow drying phase after the spreading of the layer. The spreading itself and subsequent treatments after the drying period are possible to perform in a way to facilitate serial production of MEAs. It was decided to improve the basic method by automating the spreading process and using solvents, which dry more rapidly than glycerol. The improvements were discussed beforehand with KTH's scientific staff¹, Sweden, which has experience with similar type of manufacturing processes of MEAs.

As to the methods of serial production reported, in addition of methods based on ink (slurry) containing ion-exchanger and catalyst particles, solventless (dry) spraying and vacuum-sputtering of catalyst directly on the PEM-surface should be mentioned.

The diagram in Figure A1 shows the procedure, which is followed in preparation of the electrodes. The method is based on Ref:s A1–A3. The spreading of the slurry (“ink”) was done directly on the membrane.

¹ Jari Itonen, KTH, private communication, June 2001.

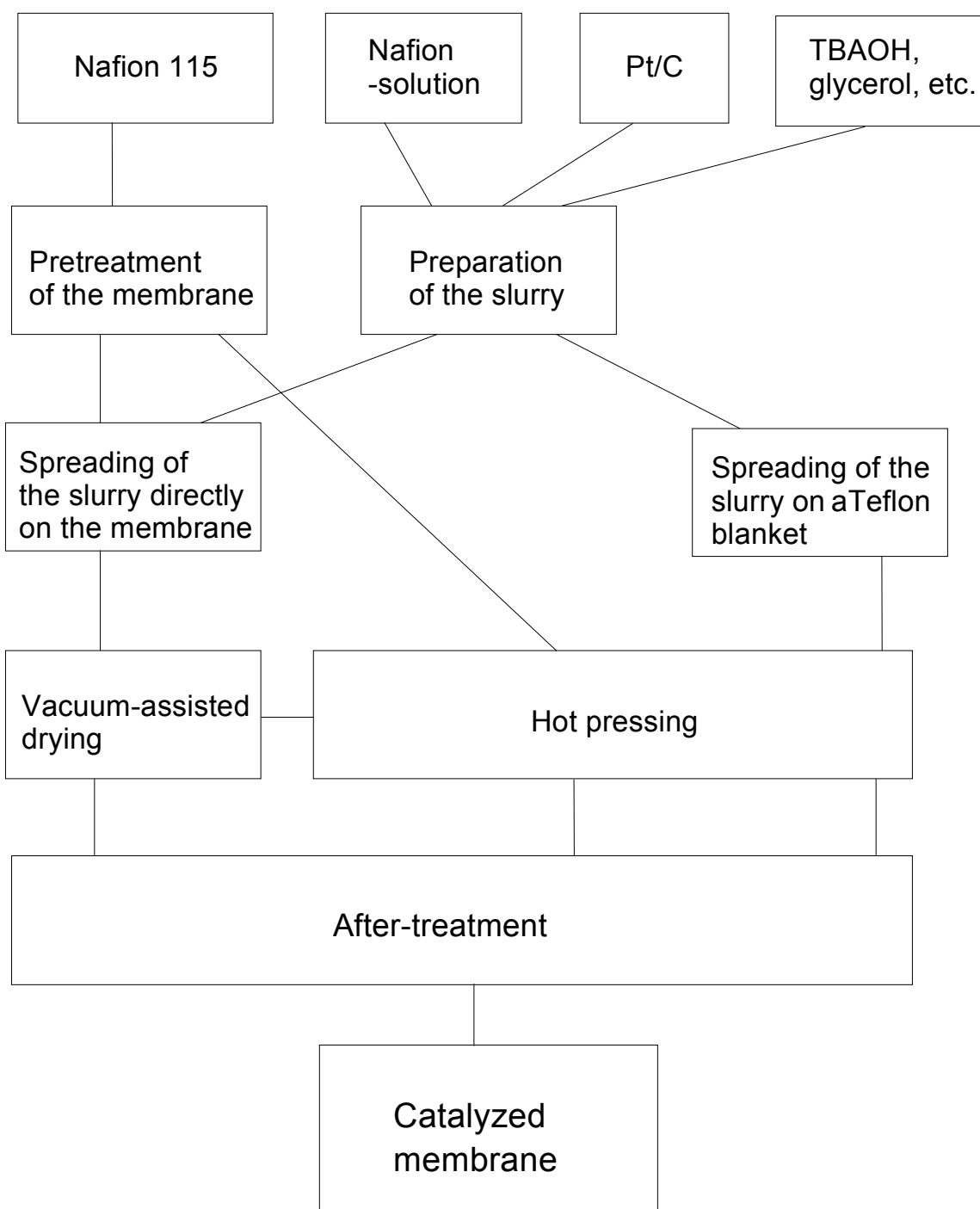

Figure A1. Fabrication of the electrodes on proton conducting Nafion membrane.

References of Appendix 1

Wilson, M. S. & Gottesfeld, S. 1992a. High Performance Catalyzed Membranes of Ultra-low Pt Loadings for Polymer Electrolyte Fuel Cells. *J. Electrochem. Soc.*, February, pp. L28–L30. (Vol. 139, No. 2.)

Wilson, M. S. & Gottesfeld, S. 1992b. Thin-film catalyst layers for polymer electrolyte fuel cell electrodes. *J. Appl. Electrochem.* 22, pp. 1–7.

Wilson, M. S., Valerio, J. A. & Gottesfeld, S. 1995. Low platinum loading electrodes for polymer electrolyte fuel cells fabricated using thermoplastic ionomers. *Electrochimica Acta.*, pp. 355–363. (Vol. 40, No. 3.)

Wilson, M. S. 1993. Membrane catalyst layer fo fuel cells. United States Patent. (5,211,984, 5234777.)



Author(s) Kumpulainen, Heikki, Peltonen, Terttu, Koponen, Ulla, Bergelin, Mikael, Valkiainen, Matti & Wasberg, Mikael			
Title In situ voltammetric characterization of PEM fuel cell catalyst layers			
Abstract <p>In our work we have studied in-house made MEA:s (geometric area 5 cm²) based on commercial (E-TEK, Inc.) carbon supported Pt and Pt/Ru catalysts. A Nafion 115 membrane was coated with ink containing Pt/C catalyst and Nafion solution and dried layers were sintered by hot pressing. After post-processing the membranes were installed in a single cell test fixture. In addition, the ink used for coating was characterized in thin film form in sulphuric acid electrolyte and the results were compared to the fuel cell data.</p> <p>Current-voltage characteristics were measured after a running-in period of about 16 hours. After cooling the test fixture down to room temperature the cyclic voltammograms were taken in situ by using a two-electrode potentiostatic measurement circuit. The electrode under study is purged by an inert gas (N₂) while the other electrode is purged by hydrogen gas so as to form a reversible hydrogen electrode. In this manner the surface processes taking place on both the anode and cathode side of the MEA could be measured and evaluated.</p> <p>From the hydrogen desorption charge on Pt the available Pt surface area has been determined and the ratio between measured area and calculated total Pt area was in the range of 30%. The ratios between electrochemical surface areas on the anode and cathode side compare well with the corresponding ratios obtained from calculations of total added Pt surface area. The relation between the voltammetrically obtained surface areas and the polarization data (current-voltage curves) is discussed.</p> <p>An enlargement of the active surface area could be noted after potential scans into the Pt oxide formation region This indicates the presence of a deactivation process, probably due to adsorbed organic material removed oxidatively during the extended polarization. When MEAs based on Pt/Ru alloy catalysts were measured the hydrogen adsorption charge decreased as a result of the lower hydrogen adsorption capability of Ru. In the double layer region the formation of Ru-oxides was also well manifested.</p>			
Keywords fuel cells, PEMFC, catalysts, layers, membrane electrodes, characteristics, measurement, electric current, voltage, cyclic voltammetry			
Activity unit VTT Processes, Otakaari 3 A, P.O.Box 1404, FIN-02044 VTT, Finland			
ISBN 951-38-5887-1 (soft back ed.) 951-38-5888-X (URL: http://www.inf.vtt.fi/pdf/)		Project number	
Date May 2002	Language English	Pages 28 p. + app. 4 p.	Price A
Name of project Manufacturing and Optimization of PEM Fuel Cells		Commissioned by Tekes	
Series title and ISSN VTT Tiedotteita – Meddelanden – Research Notes 1235-0605 (soft back edition) 1455-0865 (URL: http://www.inf.vtt.fi/pdf/)		Sold by VTT Information Service P.O.Box 2000, FIN-02044 VTT, Finland Phone internat. +358 9 456 4404 Fax +358 9 456 4374	

Membrane Electrode Assemblies for Polymer Electrolyte Fuel Cells were made on Nafion 115 membrane coating with ink containing Pt/C catalyst and Nafion. After post-processing the membranes were installed in a single cell test fixture. In addition, the ink used for coating was characterized in thin film form in sulphuric acid electrolyte and the results were compared to the fuel cell data. The cyclic voltammograms were taken in situ by using a two-electrode potentiostatic measurement circuit. From the hydrogen desorption charge on Pt the available Pt surface area was determined and the ratio between measured area and calculated total Pt area was in the range of 30%. The ratios between electrochemical surface areas compare well with the corresponding ratios obtained from calculations of total added Pt surface area. The relation between the voltammetrically obtained surface areas and the polarization data is discussed.

Tätä julkaisua myy
VTT TIETOPALVELU
PL 2000
02044 VTT
Puh. (09) 456 4404
Faksi (09) 456 4374

Denna publikation säljs av
VTT INFORMATIONSTJÄNST
PB 2000
02044 VTT
Tel. (09) 456 4404
Fax (09) 456 4374

This publication is available from
VTT INFORMATION SERVICE
P.O.Box 2000
FIN-02044 VTT, Finland
Phone internat. + 358 9 456 4404
Fax + 358 9 456 4374