



Ilkka Hannula

Hydrogen production via thermal gasification of biomass in near-to-medium term

ISBN 978-951-38-7191-8 (URL: <http://www.vtt.fi/publications/index.jsp>)
ISSN 1459-7683 (URL: <http://www.vtt.fi/publications/index.jsp>)

Copyright © VTT 2009

JULKAISIJA – UTGIVARE – PUBLISHER

VTT, Vuorimiehentie 3, PL 1000, 02044 VTT
puh. vaihde 020 722 111, faksi 020 722 4374

VTT, Bergsmansvägen 3, PB 1000, 02044 VTT
tel. växel 020 722 111, fax 020 722 4374

VTT Technical Research Centre of Finland, Vuorimiehentie 5, P.O. Box 1000, FI-02044 VTT, Finland
phone internat. +358 20 722 111, fax +358 20 722 4374

Technical editing Mirjami Pullinen



Series title, number and
report code of publication

VTT Working Papers 131
VTT-WORK-131

Author(s) Ilkka Hannula		
Title Hydrogen production via thermal gasification of biomass in near-to-medium term		
Abstract <p>Dedicated biomass gasification technologies are presently being developed in many countries for the production of second-generation liquid biofuels. Both fluidised-bed gasification and special entrained flow systems are under intensive development. These technologies can also be used for hydrogen production, which may become an interesting alternative in replacing part of fossil fuel input in oil refineries and chemical industries. In addition, fuel cell technology is being developed for hydrogen-rich gases.</p> <p>New and revolutionary production methods, capable of replacing the classical process routes, can not however be foreseen to emerge in the medium-term. Also the new hydrogen separation technologies, presently under development, seem to have only limited potential to reduce the production cost of hydrogen compared to commercially available technology. However, with rising prices of fossil fuels and locally depleting natural gas reserves, gasification route is likely to gain more ground as a credible production technology for hydrogen.</p> <p>The global needs to cut down the CO₂ emissions can also make gasification of biomass an interesting possibility. Several biomass gasification processes are presently at demonstration phase, mostly aimed for the production of liquid transportation fuels. If and when this technology will be commercialized, it could easily be adopted to the production of hydrogen.</p>		
ISBN 978-951-38-7191-8 (URL: http://www.vtt.fi/publications/index.jsp)		
Series title and ISSN VTT Working Papers 1459-7683 (URL: http://www.vtt.fi/publications/index.jsp)		Project number 20700
Date September 2009	Language English	Pages 41 p.
Name of project UCGFunda	Commissioned by Tekes, VTT, TKK, ÅA, Carbona/Andritz, Foster Wheeler Energia Oy, Metso Oyj, Neste Oil Oyj, UPM-Kymmene Oyj, Stora Enso Oyj, Vapo Oy	
Keywords biomass, gasification, hydrogen, demonstration, state-of-the-art	Publisher VTT Technical Research Centre of Finland P.O. Box 1000, FI-02044 VTT, Finland Phone internat. +358 20 722 4520 Fax +358 20 722 4374	

Preface

The objective of this report is to review the present status of technologies able to produce hydrogen via thermal gasification of biomass in near-to-medium term. The report is prepared for and reviewed by the participants of IEA HIA Task 27 “Near market routes to hydrogen by co-utilisation of biomass as a renewable energy source with fossil fuel”.

Ilkka Hannula

Contents

Preface	5
1. Introduction	9
2. Technology descriptions	10
2.1 Biomass pre-treatment.....	10
2.2 Gasification	10
2.2.1 Autothermal gasification	11
2.2.2 Allothermal gasification	12
2.2.3 Fluidised-beds reactors	13
2.2.4 Entrained flow reactors.....	13
2.3 Tar treatment technologies	13
2.3.1 Physical removal of tars	14
2.3.2 Thermal cracking of tars.....	14
2.3.3 Catalytic reforming of tars	15
2.4 Water-gas shift reaction	16
2.5 Hydrogen separation.....	17
2.5.1 Adsorbents	17
2.5.2 Membranes	17
3. Principal process alternatives	19
3.1 Hydrogen from fossil feedstocks	19
3.1.1 Steam reforming of hydrocarbons	19
3.1.2 Coal gasification	20
3.2 Hydrogen via gasification of biomass.....	21
3.2.1 Traditional concept with high and low temperature shifts	22
3.2.2 Water-gas-shift with Pressure Swing Adsorption.....	23
4. Selected ongoing biomass gasification projects and processes	24
4.1 Steam/oxygen blown fluidised-bed gasification.....	24
4.1.1 Ultra Clean Gas process, Finland.....	24
4.1.2 NSE Biofuels, Finland	26
4.1.3 UPM & Carbona/Andritz & GTI Renugas	28
4.2 Indirect steam gasification	28
4.2.1 Repotec, TUW (Güssing)	28

4.2.2	Güssing Biomass CHP, Austria.....	29
4.2.3	SilvaGas, US.....	31
4.2.4	AER gasification by ZSW, Germany.....	32
4.3	Oxygen-blown entrained-flow gasification.....	32
4.3.1	CHOREN 3-stage gasification process	32
4.3.2	Beta plant, CHOREN.....	33
4.3.3	Chemrec black liquor gasification.....	35
4.3.4	DP-1, Piteå Sweden	35
4.3.5	FZK Bioliq, Lurgi.....	37
4.3.6	MILENA gasifier, ECN.....	38
4.4	Other technologies.....	39
4.4.1	BioMCN, the Netherlands.....	39
5.	Conclusions.....	40
	References	41

List of Acronyms

AER	Absorption enhanced reforming
BFB	Bubbling fluidised-bed
BTL	Biomass to liquids
CFB	Circulating fluidised-bed
CHP	Combined production of heat and power
CTL	Coal to liquids
FICFB	Fast internally circulating fluidised-bed
IGCC	Integrated gasification combined cycle
LHV	Lower heating value
ppm	Part(s) per million
PSA	Pressure swing adsorption
SNG	Synthesis natural gas
SOFC	Solid-oxide fuel cell
WGS	Water gas shift

1. Introduction

When biomass grows, it stores the solar energy of the Sun to the chemical bounds of its molecules. This energy can later be used to produce heat and power, or converted to solid, liquid or gaseous fuels for numerous energy applications.

Several process routes exist for the production of hydrogen-rich gases, which can then be used as such or upgraded to pure hydrogen. Possible hydrogen consumers include fuel cell power plants where power could be generated with very high efficiency, and refineries where hydrogen is used for the up-grading of heavy oil fractions into higher quality products.

Technologies suitable for the production of hydrogen from biomass can be divided into two major pathways, the Biological and Thermochemical route (Figure 1). This review focuses on the latter with a special interest in the thermal gasification of biomass. For a reader in the need of a broader overview including also the biochemical route a review by Milne et al. (2001) can be recommended.

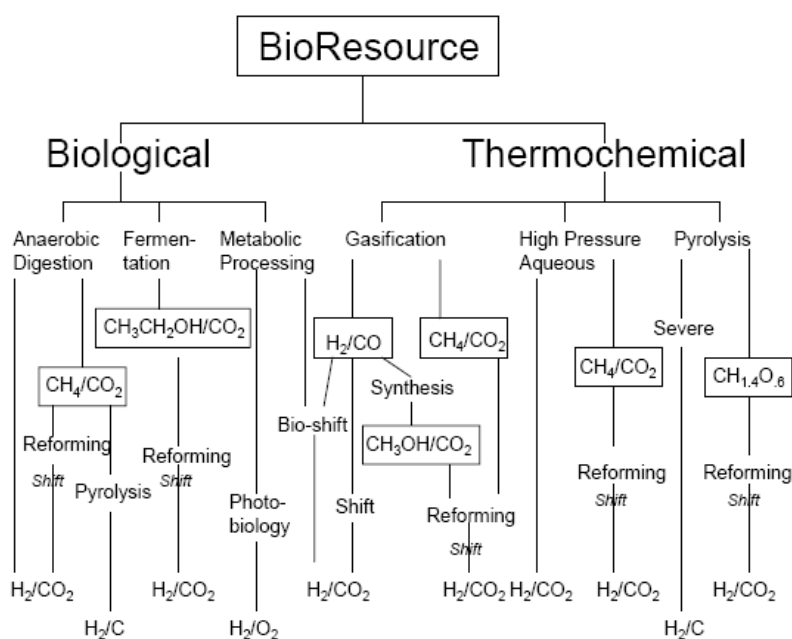

Figure 1. Pathways from Biomass to Hydrogen. Storable intermediates are shown in boxes. (Milne et al. 2001.)

2. Technology descriptions

2.1 Biomass pre-treatment

Energy processes that use biomass as feedstock are usually sensitive to the changes in feedstock quality. For this reason, several kinds of pre-treatment technologies have been developed for making biomass more homogeneous in terms of size, moisture content and density.

Biomass feedstocks are extremely varied in chemical composition and physical appearance. Particularly the moisture content and ash composition can vary greatly. The presence of fuel derived sulphur in the product gas is normally problematic for gasification processes, but less so for biomass than coal feedstocks.

For synthesis gas production purposes, feedstock moisture content must usually be dried down to 30–15 %. Drying to low moisture contents is however problematic and has not been optimised for biomass conversion processes.

At present, most common dryers used at bioenergy plants are direct rotary dryers, but the use of steam drying techniques are increasing because of easy integration to existing systems and the lack of gaseous emissions. On the other hand, steam dryers produce aqueous effluents that often need treatment. (Fagernäs et al. 2008.)

When biomass is to be transported over a long distance, the need for technology that increases energy density of the feedstock becomes apparent. These energy density upgrading technologies include both thermo-mechanical and thermo-chemical means like pelletisation, torrefaction and pyrolysis.

2.2 Gasification

Gasification occurs when biomass is heated under sub-stoichiometric combustion conditions. The result of gasification is a combustible gas mixture (called product gas, synthesis gas or syngas) rich in carbon monoxide and hydrogen. Syngas has an energy content of 5–20 MJ/Nm³, depending on the feedstock and whether gasification is conducted with air, oxygen or indirect heating.

Virtually any carbonaceous feedstock can be gasified to syngas, with high carbon conversion and good thermal efficiency. Syngas can then be further converted to serve various energy uses. An interesting option is the possibility to convert biomass to hydrogen-rich gas / pure hydrogen for high efficiency electricity generation with fuel cells or for up-grading of heavy oil fractions at oil refineries. Gasification reactors can be divided into several categories depending on the way of heat-transfer and gasification medium. The main characteristics of these different approaches will be discussed briefly in the text below.

2.2.1 Autothermal gasification

Autothermal and allothermal gasification are the main technologies used for syngas production. Low-LHV (Lower Heating Value) syngas can be produced with autothermal processes using air as the oxidising agent and medium-LHV syngas by allothermal or steam/oxygen blown autothermal gasification.

Autothermal processes generate enough heat to sustain themselves in the reaction temperature. These kinds of reactors are relatively cheap to construct because no heat transfer area has to be mounted inside the gasifier, but they can also be inconvenient to operate, due to the lack of temperature control by means of cooling medium. Thus the only way to control temperature inside the reactor is to feed excess of one of the components or to use a diluent.

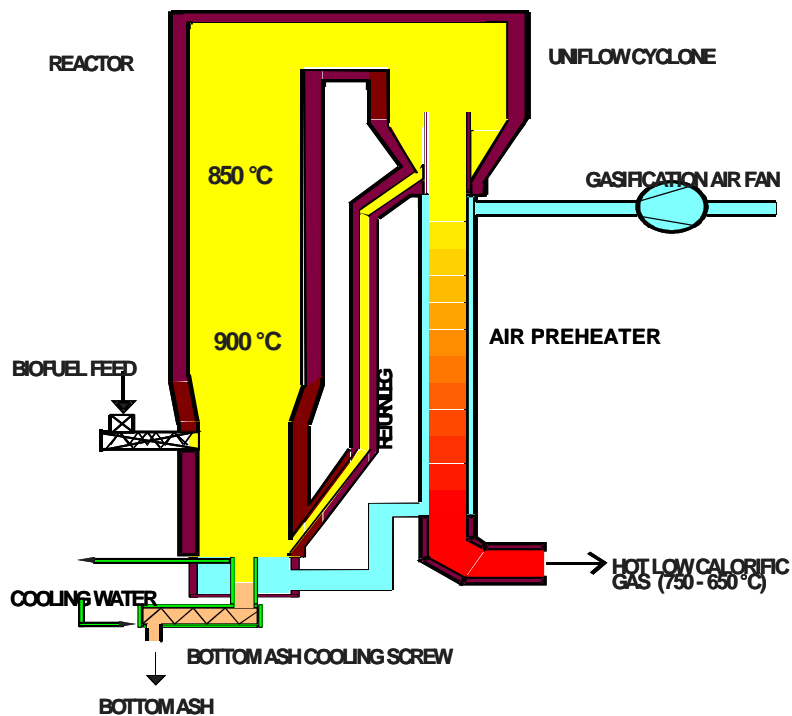

Figure 2. Foster Wheeler circulating fluidised-bed gasifier.

2. Technology descriptions

The Foster Wheeler pressurised steam/oxygen blown CFB gasifier illustrated in Figure 2 is an example of an autothermal reactor suitable for biomass gasification. The gasifier is refractory lined and complemented with an uniflow cyclone. No heat transfer surfaces are mounted inside the gasifier, but an air preheater has been integrated into the gas duct just below the cyclone. The gasifier can be operated flexibly according to different fuels and applications. Normal operating temperatures for woody biomass are in the range of 850–900 °C.

2.2.2 Allothermal gasification

In allothermal (indirectly heated) gasifiers the heat required for the gasification reactions is produced outside the reactor and then transferred inside. One of the major advantages of allothermal gasification is the ability to produce medium-heating value gas without the need of expensive oxygen separation technology. Allothermal gasifiers are usually either heated by heat exchangers inside the gasifier, or circulated hot bed material is used to transfer the heat between combustion and gasification zone.

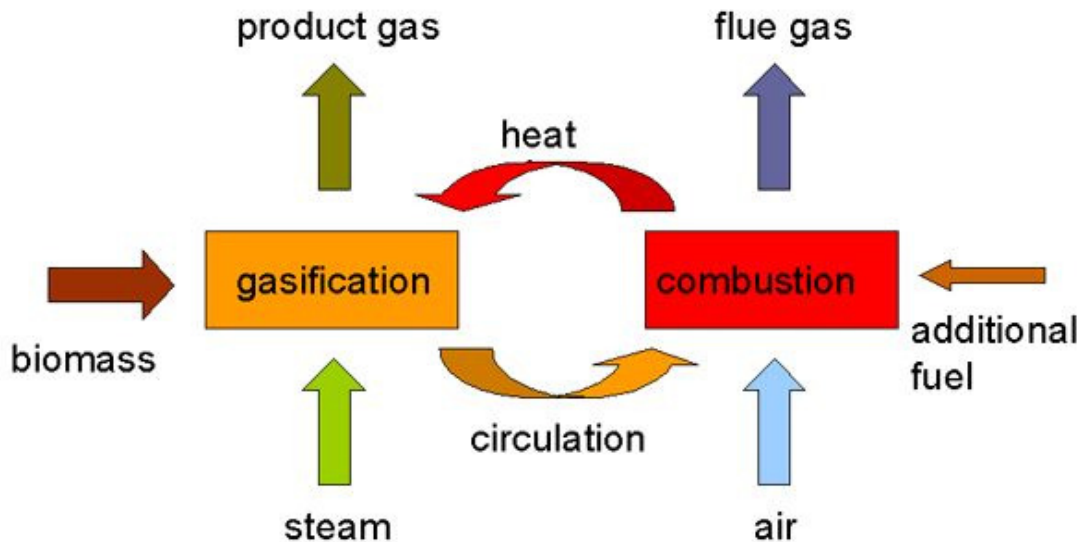

Figure 3. Illustration of the operating principle of an allothermal gasifier (www.ficfb.at).

Examples of this kind of technology include the Battelle (Figure 17) and FICFB (Figure 14) gasifiers. Both of these processes use two physically separate reactors: 1) a gasifier where biomass is converted to medium-heating value gas and residual char, and 2) a combustor where the residual char is combusted to provide heat for the gasification. The heat transfer is carried out by circulating solid bed material (sand) between these two reactors.

2.2.3 Fluidised-beds reactors

In fluidised-bed reactors a fluid (gas or liquid) is blown from the bottom of the reactor causing the bed to suspend and behave as though it were a liquid. This method of contacting has some unusual characteristics that can be utilized for biomass gasification.

Due to the liquid-like behaviour, the fluidised-beds are very well mixed, which effectively eliminates the concentration and temperature gradients inside the reactor. The process is also fairly simple and reliable to operate as the bed acts as a large thermal reservoir that resists rapid changes in temperature and operation conditions.

The disadvantages of the process include the need for recirculation of the entrained solids carried out from the reactor with the fluid, and the nonuniform residence time of the solids that can cause poor conversion levels. The abrasion of the particles can also contribute to serious erosion of pipes and vessels inside the reactor. (Kunii & Levenspiel 1991.)

Examples of fluidised-bed gasifier manufacturers include Foster Wheeler, Carbona, Austrian Engineering and Lurgi.

2.2.4 Entrained flow reactors

Entrained flow reactors use atomised liquid, slurry or dry pulverised solid as a feedstock. The pre-treatment of biomass (drying, pulverisation) is a major operation in terms of the equipment size, ancillary energy consumption and cost. Once pumped inside the gasifier, the feedstock is gasified with oxygen in a co-current flow. The temperatures are usually very high in comparison to fluidised-beds ranging from 1 300 to 1 500 °C. High temperature cracks the tars thermally into lighter hydrocarbons and causes the ash to melt. This melted ash has then to be removed from the bottom of the gasifier in the form of slurry.

Because of strict pre-treatment requirements and harsh conditions inside the reactor, entrained flow gasifiers usually need a very large scale in order to be economic, thus posing challenges for the commercialisation of biomass applications usually confined in smaller scales due to biomass availability.

Examples of entrained flow gasifier manufacturers include Shell, Conoco-Phillips, Texaco and Future Energy (formerly Noell / Babcock Borsig Power).

2.3 Tar treatment technologies

In addition to the main gas components, biomass-derived product gas contains a variable amount of organic and inorganic impurities as well as particulates. The organic impurities range from low to high molecular weight hydrocarbons. While the low-

2. Technology descriptions

weight hydrocarbons can be used as fuel in many applications (e.g. gas turbines and IC engines), heavy hydrocarbons have usually to be treated before end-use.

The higher molecular weight (polynuclear aromatic) hydrocarbons are normally referred as “tars”. Although the exact definition of tars is not always clear, tars are commonly defined as those fractions of hydrocarbons in the product gas that condense in ambient conditions.

Regardless of the exact definition of tars, removal of these heavier organic compounds from product gas is a key technological challenge for virtually every biomass gasification application. Typical tar-related problems in gasification systems include blocking of heat exchangers, pipes and other low-temperature surfaces as well as particulate filters.

Numerous ways to effectively and economically solve the tar-related problems have been tried, and some of the most widely applied methods are discussed briefly in the following chapters.

2.3.1 Physical removal of tars

Tar treatment systems can usually be divided to high and low temperature methods. Physical removal systems, such as wet scrubbing and filtering, are low temperature technologies, and most suitable for gasification processes where low, near-ambient temperature product gas is required (e.g. IC engine applications).

Tar elimination by condensation, e.g. wet scrubbing is widely used with gasification applications. Benefits of this technology include simplicity of operation and a relatively low cost. The main disadvantage of scrubbing is the tar-laden end-product that requires further treatment before discharge from the process. In other words, condensing systems often do not solve the tar problem itself, but transfer it from a gaseous to liquid phase. Another disadvantage of the physical removal system includes the loss of chemical energy, caused by the removal of tars from the product gas, thus contributing to a lower overall efficiency of the process. (Dayton 2002.)

2.3.2 Thermal cracking of tars

Hot-gas cleaning technologies are desirable for gasification processes where product gas has a high end-use temperature (Physical removal systems are still a possibility, but the reheating of tar-free gas stream back to end-use temperature causes thermodynamical penalties). During hot-gas cleaning tars are converted into desired components while preserving their chemical energy in the syngas.

Usually cracking of tars requires much higher temperatures than would be necessary from gasification point of view and in many cases, even temperatures over 1 100 °C have to be applied if high conversions are desired. The required temperature increase can

be obtained by partially combusting syngas with air or oxygen, causing thermodynamical penalties in the process. It is also possible that soot, a very unwanted impurity, will form as a by-product in this process. (Dayton 2002.)

2.3.3 Catalytic reforming of tars

Catalytic reforming aims to combine the positive features of thermal cracking while at the same time trying to avoid thermodynamical penalties and soot formation. It also enables better thermal integration of the tar treatment system to the gasifier and allows adjusting syngas composition.

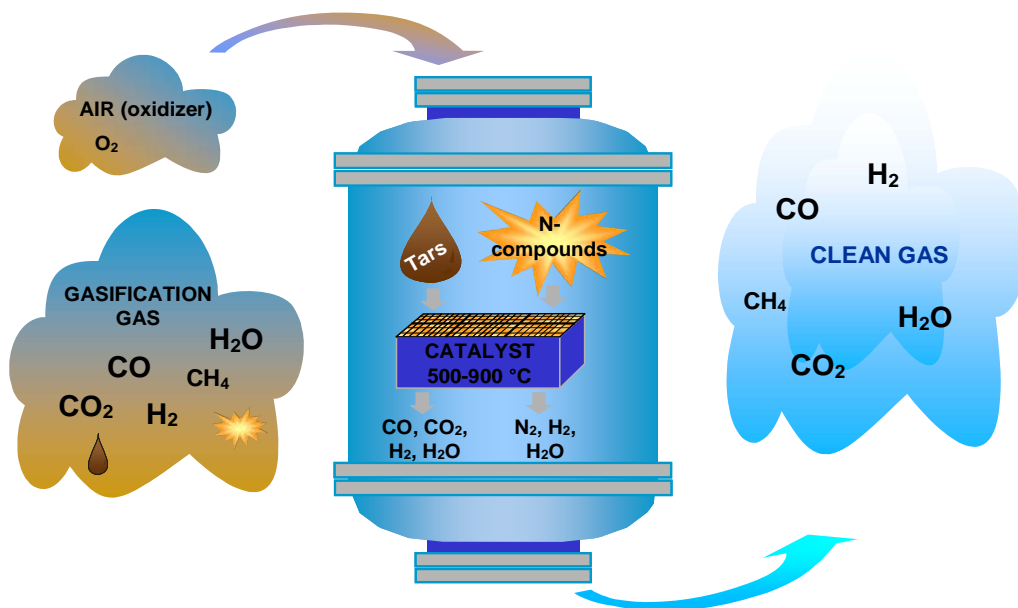

Figure 4. In a catalytic reformer the tars and nitrogen compounds are converted to elemental gases.

Numerous catalysts have been tested for their ability to convert tars and tolerate impurities during the decades of R&D on catalytic tar reforming. Present focus of catalyst development work is directed to achieve higher activities, longer lifetimes and improved tolerances towards impurities.

Three groups of catalyst metals are normally applied with biomass gasification systems: alkali metals, non-metalleic oxides and supported metallic oxides. Alkali metals are not suitable catalysts for tar reforming, but because of their ability to enhance biomass gasification reactions they are often mixed with bed material in the gasification zone.

Non-metallic and supported metallic oxide catalysts can be used to reduce the amount of tars in the syngas. For these applications they are normally used as fixed beds in separate reactors downstream the gasifier. The most widely applied non-metallic tar conversion catalyst in biomass gasification is calcium magnesium carbonate i.e. dolomite.

2. Technology descriptions

Successful reforming of biomass gasification tars with supported Ni-based catalysts has also been demonstrated. (Dayton 2002.)

2.4 Water-gas shift reaction

Water-gas shift reaction (WGS) is the conversion of carbon monoxide and steam to hydrogen and carbon dioxide.



The reaction can also be used to increase hydrogen concentration in syngas. According to reaction equation above, WGS reaction does not involve net change in volume and is therefore only remotely affected by the operation pressure. The reaction is reversible, with forward reaction being mildly exothermic and thus favoured by low temperatures. Higher temperatures will increase the rate of reaction, but decrease the yield of hydrogen. So, in order to simultaneously achieve high yields at high rates of reaction, WGS is usually carried out in both high and low temperatures.

Table 1. Main R&D goals for water-gas shift catalyst in the DOE's Hydrogen from Coal Programm (Miller et al. 2008).

Performance Criteria	Units	Current Status	2010	2015
Reactor Type	-	Multiple fixed beds	Advanced configurations - tbd	
Catalyst Form	-	Pellets	Advanced configurations - tbd	
Active Metal	-	Cu/Zn or Fe/Cr or Co/Mo	Advanced configurations - tbd	
Feed Temperature	°C	200–300	>250	>400
Feed Pressure	psia	450–1150	>450	>750
Approach to Equilibrium	°C	8–10	<6	<4
Min. Steam/CO Ratio	Molar	2.6	<2.6	<2
Sulfur Tolerance, ppmv	-	Varies	>20	>100
COS Conversion	-	Varies	Partial	Total
Chloride Tolerance, ppmv	-	Varies	> 3	>100
Stability/Durability	Years	3–7	>7	>10
Catalyst Cost	\$/lb	~5	<5	<5

In addition to staging, the yield of WGS reaction can be further improved by removing hydrogen from the reactor during reaction or by using excess amount of steam that also helps to suppress the unwanted side reactions that would otherwise occur.

For the use of commercial hydrogen production processes, several WGS catalysts have been developed. The R&D needs for the catalyst improvement include higher

hydrogen yields in high temperatures, improved tolerance against impurities, less unwanted side reactions and wider operating windows in terms of temperature and pressure. Table 1 lists the main R&D goals for WGS catalysts of DOE's Hydrogen from Coal Programme until 2015.

2.5 Hydrogen separation

When WGS reaction is used to increase the concentration of hydrogen in syngas, large amounts of carbon dioxide are produced as well. Thus, for the process to achieve high yields and high purity, WGS has to be followed by some kind of hydrogen separation technology.

2.5.1 Adsorbents

Pressure Swing Adsorption (PSA) is an adsorbent technology that can be used to separate gas species from a mixture of gases under pressure. It is based on molecular sieves, manufactured so accurately that the pore diameter of the sieve allows the separation of different sized molecules of syngas stream. The single most important feature of the PSA system is its ability to remove virtually any gas phase impurity to a required level and, as a consequence, reach very high levels of purity (99–99.99 %).

The purity level has little effect to the hydrogen yield of the PSA system while the operating pressure can vary between 18–36 bars. While the pressure of separated hydrogen is nearly at the inlet pressure, the pressure of tail gas is conversely proportional to the yield and should therefore be extracted from the process at the lowest pressure possible. The disadvantages of PSA separation include modest recovery from the feed-stream hydrogen (around 86 %) and relatively low operating temperatures. (More 1997.)

2.5.2 Membranes

Membrane separation systems are based on the preferentially selective permeation of hydrogen from a mixed gas stream through a polymer, metallic, or ceramic membrane. The typical driving force for membrane separation systems is pressure, with the exact mechanism for permeation of hydrogen through the membrane varying based on the membrane material or design. For example, microporous polymeric membranes are microporous filters that separate molecules through a molecular diffusion transport mechanism determined by the pore diameter and particle size. Metallic membranes – pure metals, metal alloys, or ceramic-metallic (cermet) composites – typically dissociate the hydrogen molecule into atoms that pass through the metal film and the atoms recombine into hydrogen molecules on the other side of the membrane. Dense ceramic

2. Technology descriptions

membranes separate hydrogen by transferring hydrogen ions (i.e. protons) and electrons through the membrane. Dense ceramic membranes generally require higher temperature operation to achieve adequate flux rates compared to other membrane technologies.

Advancements in membrane separation technologies have the potential to reduce costs, improve efficiency, and simplify hydrogen separation and purification systems. One of the advantages of hydrogen separation membranes is that they have the capability to produce ultra-high purity hydrogen for fuel cell applications. Desirable characteristics would include high hydrogen flux at low pressure drop through the membrane, tolerance to contaminants, particularly sulfur and carbon monoxide, and operation at system temperatures of 250–500 °C. (Ackiewicz 2009.)

Many hydrogen membrane separation systems are presently at the research phase and require further advancement to overcome technical challenges such as limited durability due to material or catalyst failure in the presence of contaminants and/or thermal cycling, inability to consistently fabricate defect-free membranes on a large scale, and lack of proper high-pressure seals, among others. Table 2 lists the current performance characteristics for hydrogen permeable cermet membranes under development by the U.S. Department of Energy Office of Fossil Energy and National Energy Technology Laboratory.

Table 2. Examples of Current Status of Membrane Development Activities Sponsored by FE and NETL (Miller et al. 2008).

Membrane Type	Units	Hydrogen permeable cermet
Flux ^a	ft ³ /hour/ft ²	~ 220
Temperature	°C	300–400
Sulfur tolerance	ppmv	~ 20
Cost,	\$/ft ²	< 200
Potential timing ^b	years	10+ years
ΔP Estimated ^c	psi	100
ΔP Function	-	square root

^a For 100 psi ΔP (hydrogen partial pressure basis)

^b Potential timing for development

^c ΔP Estimated – all flux rates have been corrected to an estimated 100 psi ΔP (hydrogen partial pressure basis) across the membrane at 50 psia on the permeate or sweep side.

3. Principal process alternatives

Hydrocarbons such as natural gas, coal and biomass contain hydrogen in chemically bound form and energy is needed to release and isolate it in the elementary form. The main use for hydrogen is for chemical reactions in the chemical and petroleum refining industries, but for environmental reasons hydrogen is also envisaged to serve as a source of clean fuel in the distant future.

It is difficult to try to accurately estimate the global supply and consumption of hydrogen, because hydrogen is produced either on purpose as syngas mixtures (ammonia, methanol etc.) or as by-products (e.g. coke-oven gas). In the refinery sector the situation is even more complex because most of the hydrogen needed in various operations is recovered from the by-product streams of other refinery steps.

In the past, refineries were nearly self-sufficient in hydrogen i.e. the amount of hydrogen needed and produced as by-product, were close to the same level. Tightened environmental regulations and a need to produce higher quality products have however increased the need for purposely produced hydrogen. It has been estimated that in the past 25 % of the combined supply of hydrogen in the EU and USA was produced purposely and 75 % as by-product, recovered mainly from catalytic reforming. (More 1997.)

3.1 Hydrogen from fossil feedstocks

Hydrogen can be produced commercially from hydrocarbons via two routes: steam reforming and gasification. In both cases, the primary reaction is followed by shift conversion step with final purification to achieve the required quality of product. Both production routes are discussed briefly in the following chapters.

3.1.1 Steam reforming of hydrocarbons

Steam reforming of light hydrocarbons such as natural gas, LPG, naphtha and refinery off-gases is the dominating process for the production of hydrogen. Conventional process sequence consists of steam reforming furnace followed by gas cooler before

3. Principal process alternatives

high- and low-temperature shift conversion steps. Carbon dioxide is thereafter removed by conventional scrubbing processes and the resulting hydrogen stream purified by methanation. With this traditional production process it is possible to achieve hydrogen purity between 95 to 98 % with mainly methane in tolerable impurities.

As described earlier, Pressure Swing Adsorption (PSA) technology, introduced in the 1970's, has gradually become the industrial standard for hydrogen separation at steam reforming hydrogen plants. With PSA technology it is possible to extract very high purity (> 99.99 %) hydrogen from the shift-converted gas by adsorption of molecular sieves. This allows much simplified configuration, as the PSA unit replaces three process steps in the conventional system (low-temperature shift, CO₂ removal and methanation) with one step.

3.1.2 Coal gasification

Gasification allows the conversion of (low value) carbonaceous feedstocks to high value products or intermediates, such as Fischer-Tropsch liquids, methanol, SNG and hydrogen. Coal feedstocks are often rich in sulphur (converted mainly to hydrogen sulphide and marginally to carbonyl sulphide in the gasifier) that needs to be removed from the gas stream by acid gas removal process. For the final purification, three process options exist: methanation, PSA and cryogenic purification.

In the Shell Gasification Process, sulphur compounds are normally removed before shift conversion step, i.e. is before it becomes diluted by carbon dioxide formed in WGS reaction. This however leads to the need of removing carbon dioxide later in a separate Rectisol column.

In the Texaco Gasification Process (Figure 5) syngas is quenched after gasification to provide a simple and rather inexpensive way for cooling and adding steam for the shift conversion purposes. This requires the Rectisol steps to be situated after shift conversion, demanding very sulphur-tolerant catalysts. Because hydrogen sulphide is diluted by carbon dioxide, Rectisol unit has to be equipped with a hydrogen sulphide enrichment step prior removal. There is no need, however, for COS hydrolysis stage that might have to be used with the Shell Gasification Process. (More 1997.)

3. Principal process alternatives

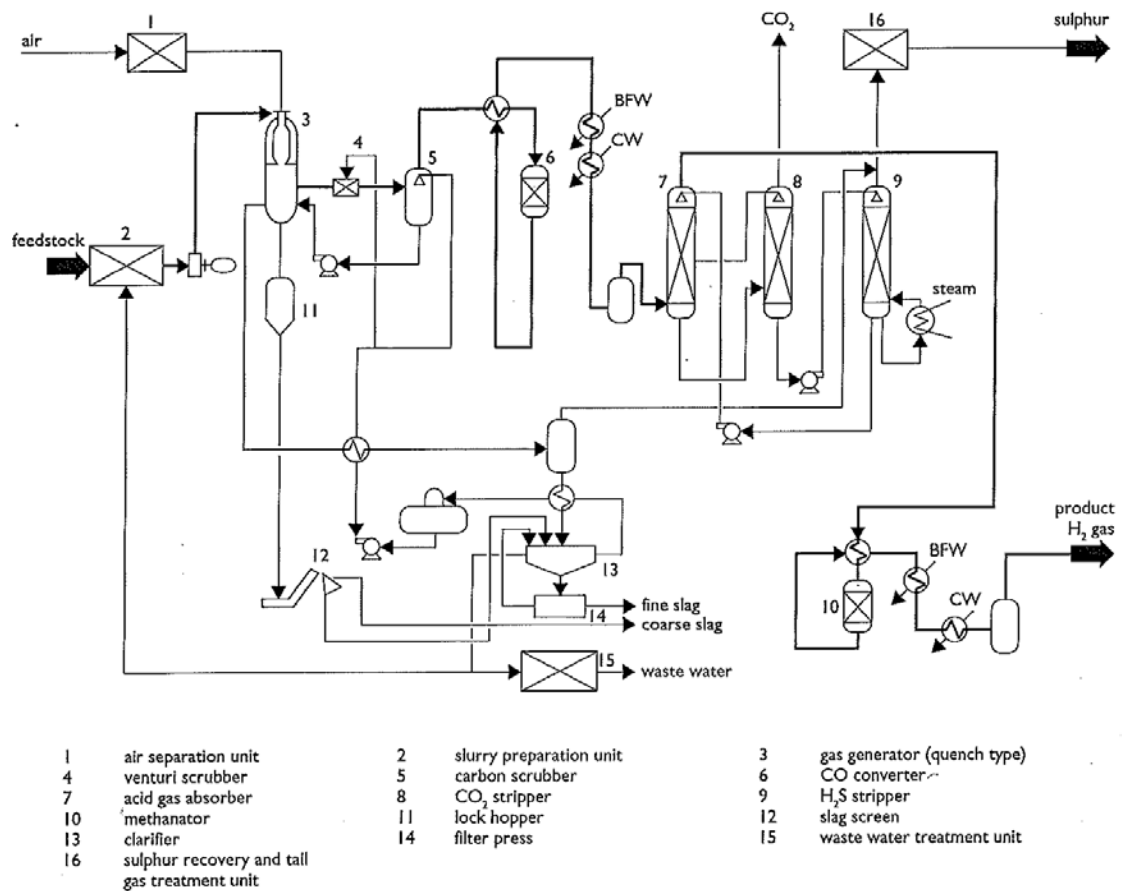

Figure 5. Hydrogen production by the Texaco Coal Gasification Process (More 1997).

3.2 Hydrogen via gasification of biomass

Although gasification of coal and oil residues has been demonstrated commercially already decades ago, biomass gasification technologies are still struggling for market entry. Many barriers are related to the challenging properties of biomass, such as inconsistent availability, low heating value and varied chemical as well as physical properties that make harvesting, transport and storing more complex and expensive for biomass than for fossil fuels.

Nevertheless, once the clean syngas has been produced, a wide variety of chemical processes already available for syngas can be readily applied. For this reason, main R&D can be focused on improving biomass gasification and tar treatment steps, while process steps downstream from tar treatment can be considered commercially available. (Kurkela et al. 2004.)

3. Principal process alternatives

In the following chapters two different process configurations are proposed for the production of hydrogen from biomass via gasification.

3.2.1 Traditional concept with high and low temperature shifts

Figure 6 illustrates a concept where traditional hydrogen process is simply adapted to biomass gasification. Biomass is first dried to 15–30 % moisture content and fed into a fluidised-bed gasifier operating at 5–10 bar. An excess amount of steam is fed to the gasifier to provide enough H₂O for the high temperature shift conversion.

Heavy hydrocarbons, exiting from the gasifier outlet, are treated catalytically at around 800–900 °C in a reformer to produce tar free syngas. The first shift reactor operates between 350–400 °C followed by cooling the gas down to 40 °C with heat exchangers and a scrubber/cooler. The syngas is then pressurized to 30 bar and fed to an acid gas removal stage where H₂O, CO₂, H₂S and other impurities are removed to a very high extent.

At the low temperature shift step, steam is once again added to reach an output H₂/CO ratio of ~ 100 %. Excess steam and CO₂ formed in the shift are once again removed in a second acid gas removal stage. Finally, a methanation step is used to convert the residual carbon monoxide to CH₄. With this traditional process it is possible to achieve hydrogen with a purity of ~ 95 %.

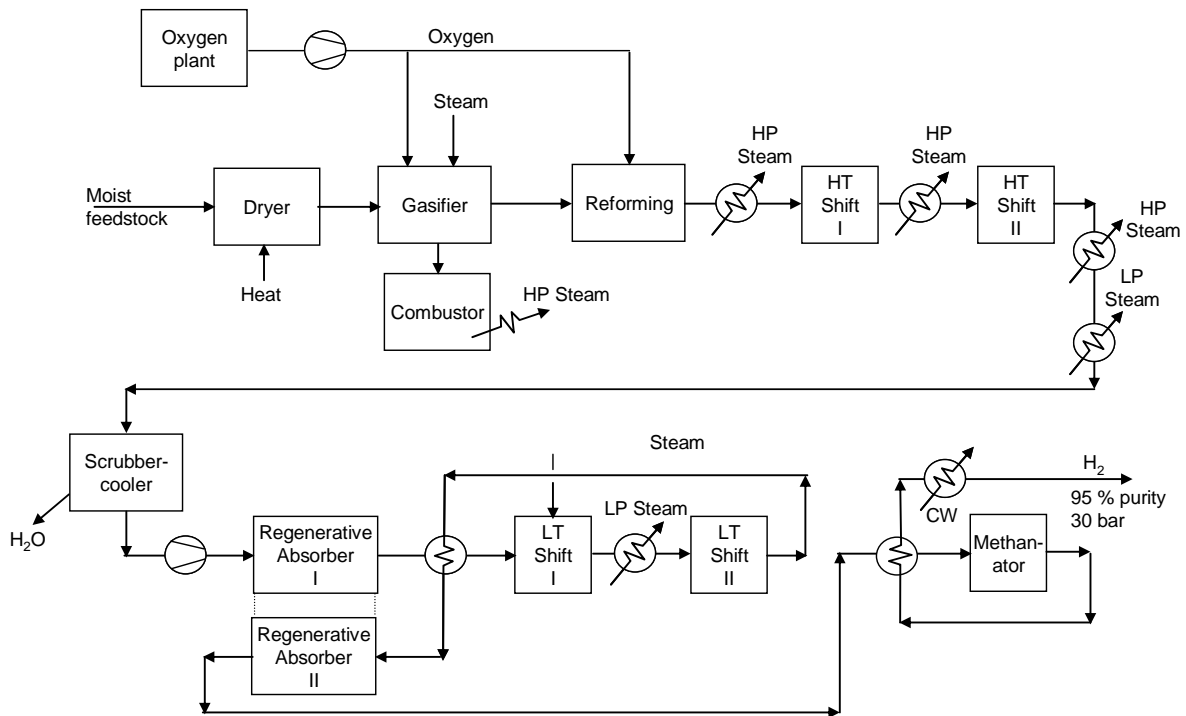

Figure 6. Schematic of a traditional hydrogen production process with high and low temperature shifts.

3.2.2 Water-gas-shift with Pressure Swing Adsorption

Figure 7 illustrates a hydrogen production concept where low temperature shift reactor has been replaced with pressure swing adsorption system. The process is otherwise similar to the traditional process upstream from the syngas compression. With the introduction of PSA there is no need to add a second absorber stage, while extremely good quality hydrogen is produced with 86 % efficiency. The purge gas is then compressed and led to a combined cycle to produce electricity.

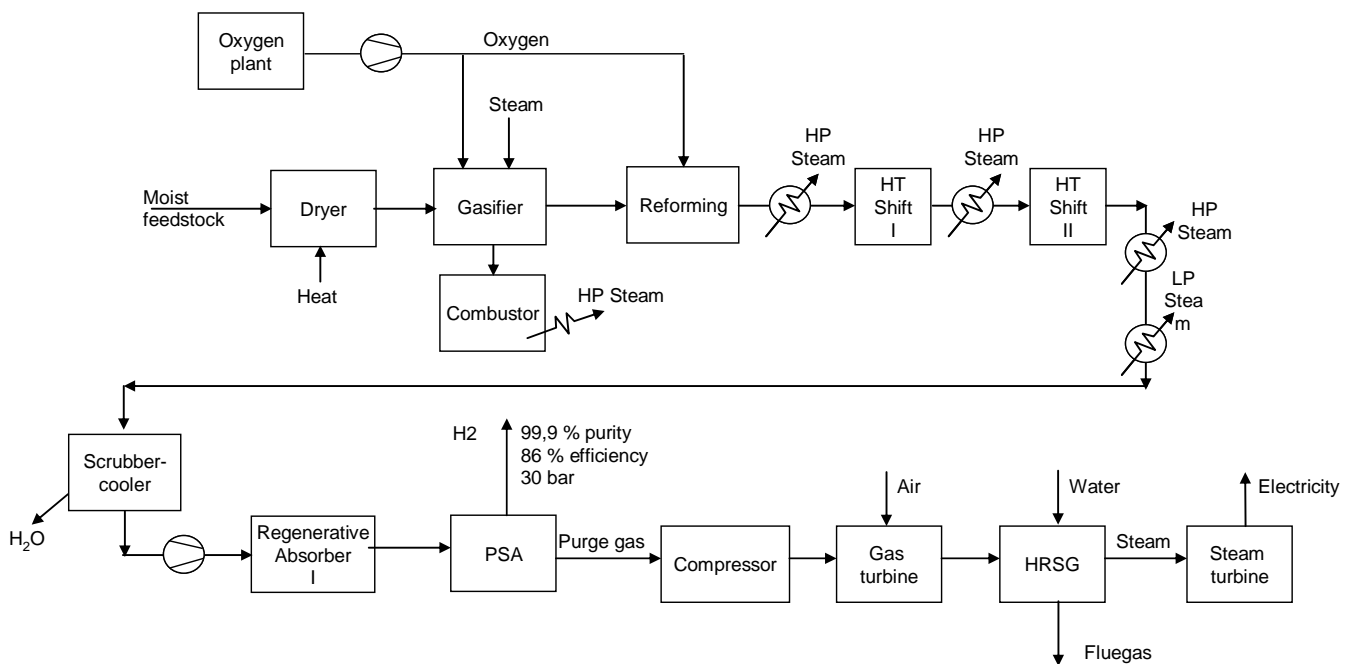

Figure 7. Schematic of a hydrogen production process with high temperature shift and pressure swing adsorption (PSA).

4. Selected ongoing biomass gasification projects and processes

In this chapter, a selection of ongoing biomass gasification projects and related activities are presented. Even though the primary objective of these projects is to develop technology for the production of transportation fuels, many of the processes could also be used for the production of renewable hydrogen.

4.1 Steam/oxygen blown fluidised-bed gasification

The earliest example of steam/oxygen blown fluidised-bed biomass gasification technology can be traced back to the Kemira Oy ammonia plant located at Oulu (Finland), where synthesis gas was produced from peat and saw dust with pressurised O₂-blown fluidised-bed (High Temperature Winkler) gasifier in 140 MW-scale during the late 1980's. The gasifier was coupled to ammonia synthesis plant originally designed for heavy oil gasification. After initial problems and some process modifications, the plant reached stable operation and commercial production of ammonia. Due to very low world market price of ammonia, the production was stopped at Oulu in early 1990's. (Kurkela et al. 2004.)

4.1.1 Ultra Clean Gas process, Finland

Experiences from the Oulu ammonia plant together with later gasification and gas cleaning R&D has led VTT (Technical Research Centre of Finland) to develop Ultra Clean Gas process for biomass and waste-derived fuels. The UCG-process is based on optimised steam/oxygen fluidised-bed gasifier and catalytic gas treatment steps that enables to use a wide range of biomass feedstocks (woody biomass, agrobiomass, peat and waste derived fuels). For the production of liquid biofuels, thermal integration with suitable industrial processes can be utilized in order to reach higher efficiencies and lower production costs (see Figure 9). (Kurkela et al. 2004.)

4. Selected ongoing biomass gasification projects and processes

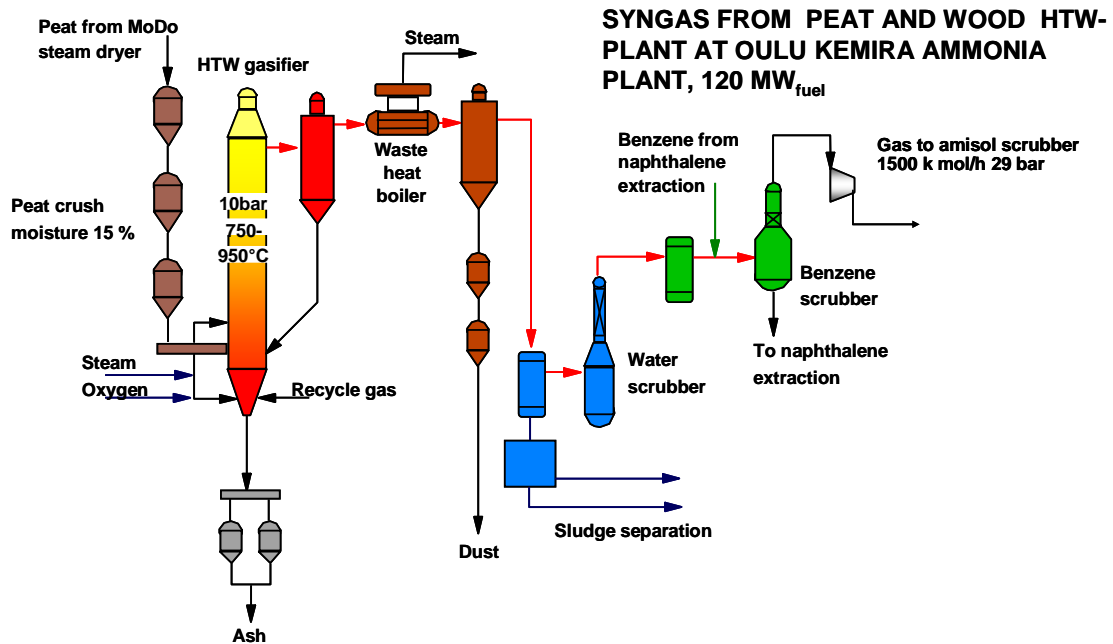

Figure 8. An illustration of a possible thermal coupling of gasification Fischer-Tropsch process to a pulp and paper mill.

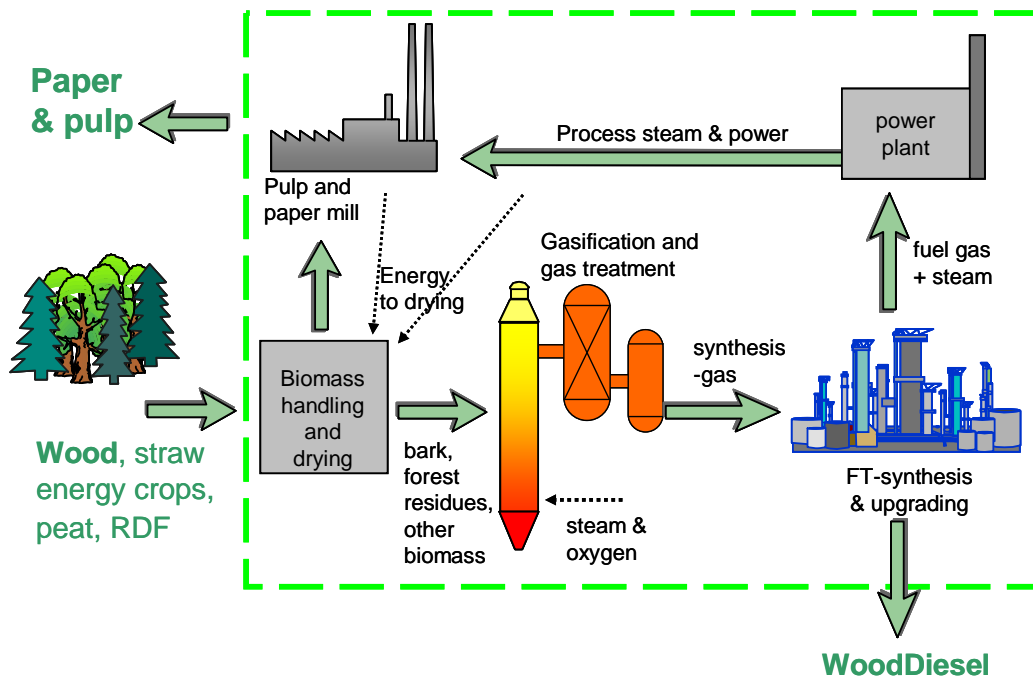

Figure 9. An illustration of a possible thermal coupling of gasification Fischer-Tropsch process to a pulp and paper mill.

The first phase of the research work on UCG-process was started at VTT in the beginning of 2000's with a 500 kW pressurized process development unit. The PDU

4. Selected ongoing biomass gasification projects and processes

gasifier can be operated either with air (power applications) or steam/O₂ (for synthesis gas production) as an oxidation agent, and coupled to an advanced high temperature filtration system as well as reformer for the catalytic treatment of tars and hydrocarbons. Slip-streams are used for analyzing, conditioning and synthesis testing.

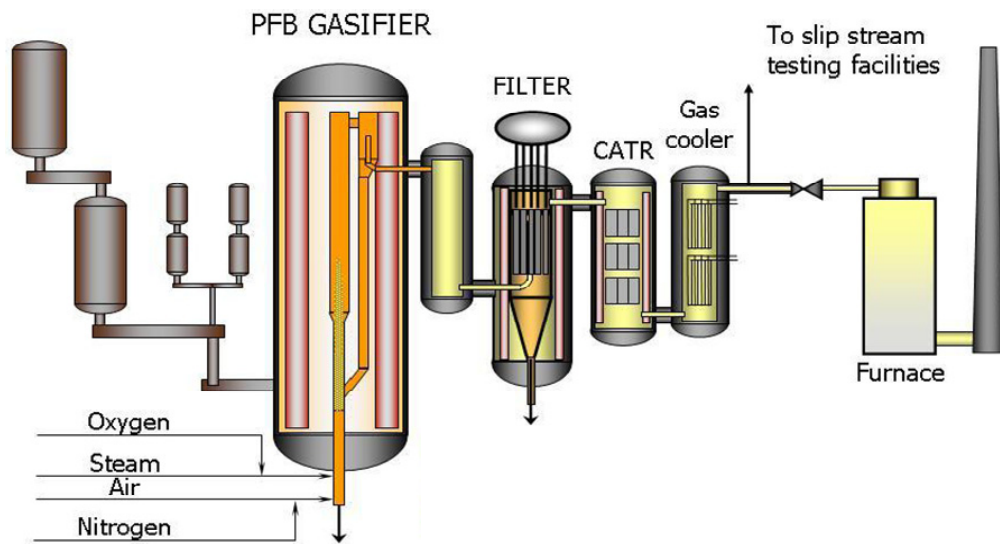

Figure 10. An illustration of the VTT's Ultra Clean Gas process concept.

The work has been focused on the gasification and gas cleaning steps. Targets for the gasifier development work have been simple design, high reliability, high carbon conversion to gas and tars, low oxygen consumption, no need for tar decomposition and avoidance of ash-related problems.

The targets for the gas cleaning step have been complete tar and benzene decomposition, over 95 % methane reforming, suitable H₂/CO ratio for FT-synthesis, reliable operation and minimum overall gas cleanup train cost. (McKeough & Kurkela 2008.)

The work that was started in this project is presently continued by NSE Biofuels.

4.1.2 NSE Biofuels, Finland

NSE Biofuels, a joint venture between Finnish oil refining company Neste Oil and Finnish pulp and paper manufacturer Stora Enso, has announced to be developing a process for the production of 2nd generation liquid biofuels from biomass.

The development and demonstration work is based on the UCG process developed by VTT. NSE Biofuels has announced that the project is currently entering demonstration phase at Stora Enso's mill in Varkaus, Finland (Figure 11).

The demonstration includes 12 MW_{syngas} atmospheric CFB gasifier replacing the current lime kiln burner. The clean-up processes will be demonstrated in a 5 MW slip stream and is expected to start during 2009.

4. Selected ongoing biomass gasification projects and processes

The project has currently four main partners:

- Neste Oil (NSE biofuels partner)
- Stora Enso (NSE biofuels partner)
- VTT (main R&D partner)
- Foster Wheeler Energia (CFB gasification technology and demonstration facility supplier).

The size of the possible commercial scale BTL production plant has been calculated to require a production of 100 000 t/a of Fischer Tropsch waxes that equals about 200–300 MW in fuel input. Foster Wheeler has announced to possess a draft layout for a full-scale gasification plant for synthesis gas production. The gasification concept could also be applied for the production of SNG, hydrogen, methanol, ethanol and electricity (IGCC).



Figure 11. A map showing the location of Varkaus in Finland.



Figure 12. A photograph from the construction site of the NSE Biofuels demonstration facility at Varkaus.

4. Selected ongoing biomass gasification projects and processes

4.1.3 UPM & Carbona/Andritz & GTI Renugas

Finnish Pulp and Paper Company UPM has announced to have teamed up with gasification technology provider Carbona/Andritz and Gas Technology Institute GTI to pursue the development of 2nd generation BtL concept. The piloting work for the process is done at GTI's facility at Des Plaines, USA and engineering work for the commercial scale plant is ongoing. Figure 13 illustrates the main aspects of the chosen process concept.

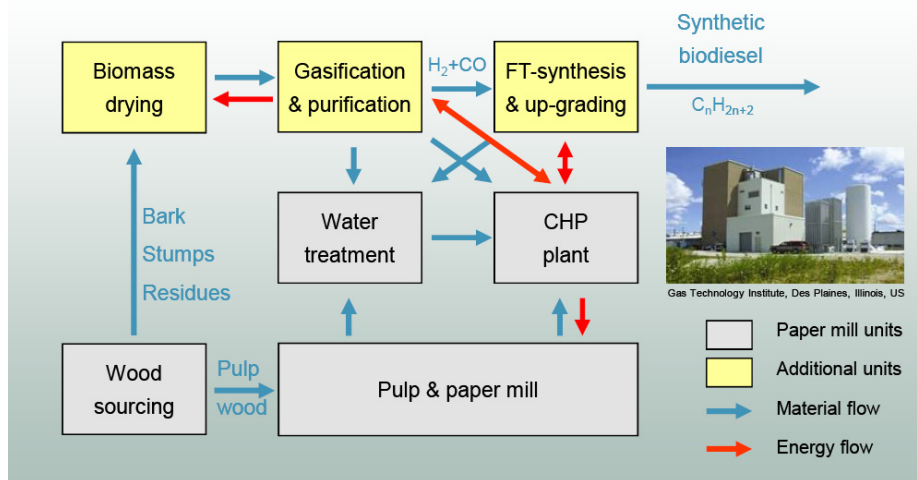

Figure 13. Schematic of the UPM's biodiesel process.

4.2 Indirect steam gasification

4.2.1 Repotec, TUW (Güssing)

Technical University of Vienna (TUW) has developed a Fast Internally Circulating Fluidised-bed (FICFB) technology, in cooperation with Austrian Energy (see Figure 14). The process is based on indirect steam gasification where biomass is gasified in a bubbling fluidised-bed at around 850–900 °C to produce nitrogen-free medium-LHV syngas. The residual carbon together with the bed material slides to the combustion zone where it is fluidised and combusted with air to generate heat for the gasification. After combustion, the particulates are separated from the flue gas with cyclone and circulated back to the gasifier. The joints between the combustion and gasification zone are fluidised with steam to prevent gas leaks between the reactors.

4. Selected ongoing biomass gasification projects and processes

Austrian Energy owns the patent for the FICFB technology but has at the moment no own activities in the area of biomass gasification. Instead, Austrian Energy has licensed the patent to Repotec and Ortner. Several commercial projects are ongoing at the moment, but are still at the design phase.

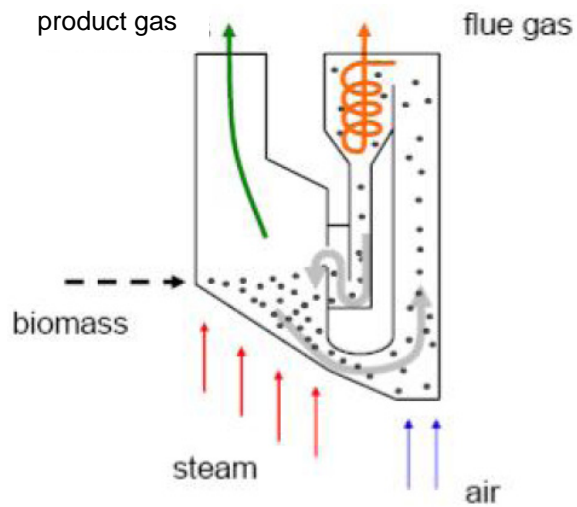

Figure 14. Illustration of the operating principle of FICFB gasifier. Source: TUW.

4.2.2 Güssing Biomass CHP, Austria

The Güssing biomass CHP plant is a demonstration site for the Fast Internally Circulating Fluidised-bed (FICFB) technology developed by Austrian Energy and Technical University of Vienna. The operating principle of the gasifier has been discussed in the previous chapter.

In 2002, a biomass gasification plant of 8 MW_{fuel} capacity was commissioned at the town of Güssing, Austria. Besides electricity, the plant is designed to produce process steam for the local wood-processing industry and heat to the district heating network (see Figure 15). The CHP plant does not include any biomass drying equipment and the moisture content of the as-received-feedstock varies between 25–40 %.

After the syngas exits the gasifier at 850 °C it is cooled down to 150 °C prior baghouse filtering unit. The tars are removed from the gas in a RME scrubber to a level of 20 mg. At the scrubber exit the gas temperature is around 45 °C and ready to be fed into GE Jenbacher IC engine. (Rauch 2008.)

4. Selected ongoing biomass gasification projects and processes

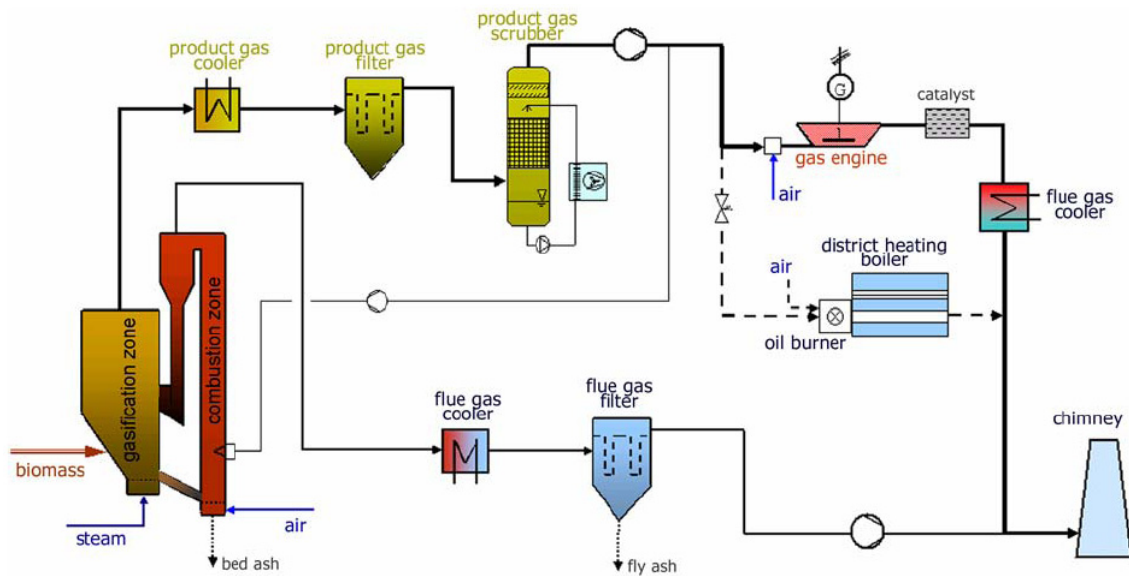

Figure 15. An illustration of the Güssing FICFB process. Source: TUW.

The Güssing CHP gasification plant has a convincing track record in terms of availability. From the year 2006 onwards, the plant has annually exceeded 6 000 hours of operation in CHP mode. The continuous flow of biomass-derived medium-LHV syngas has also enabled wide-ranging research activities in the field of syngas conversion. In the past couple of years, the plant has offered a site for several slip stream studies, including Fischer-Tropsch synthesis and solid-oxide fuel cell testing. Demonstration of a syngas methanation process in a scale of 1 MW is about to begin in early 2009. (Rauch 2009.)

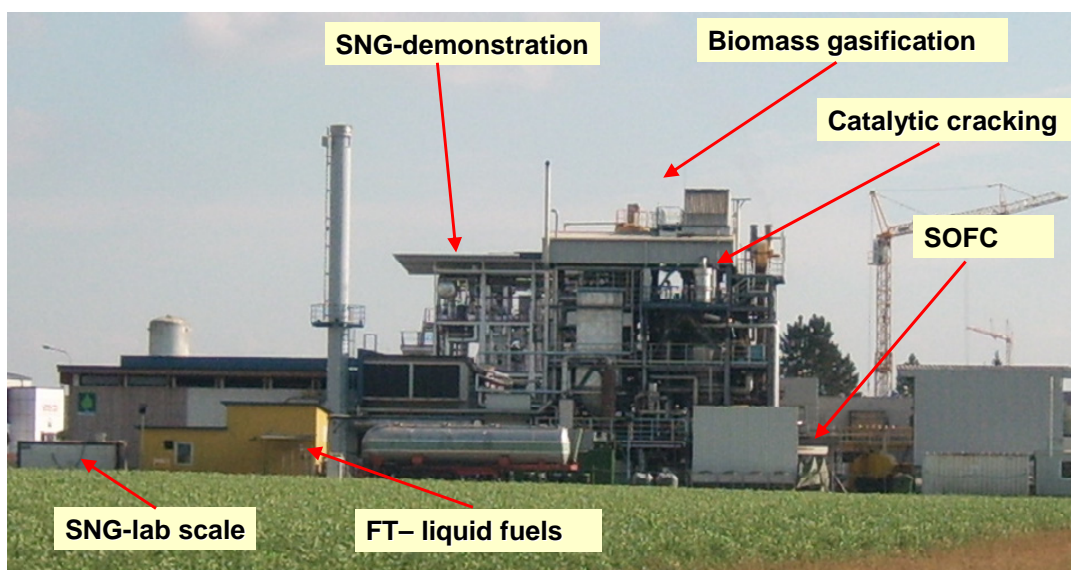

Figure 16. A photograph taken from the Güssing demonstration site. Source: TUW.

4.2.3 SilvaGas, US

The Vermont Gasification Project was a name of the development platform for the field verification of the SilvaGas process. The initial development of the indirectly heated gasifier was done at Battelle's Columbus Laboratories where it was specifically designed for the production of medium LHV gas from biomass.

Initial developments at Battelle began in 1980 and continued through 2000. Construction of the commercial scale demonstration plant (operated with 300 tons per day of biomass) was completed in 1997 and the first operation in full steam gasification occurred in August of 1999. The design of the plant included all key process systems, with the exception of heat recovery, and the product gas was co-fired in the existing power boilers.

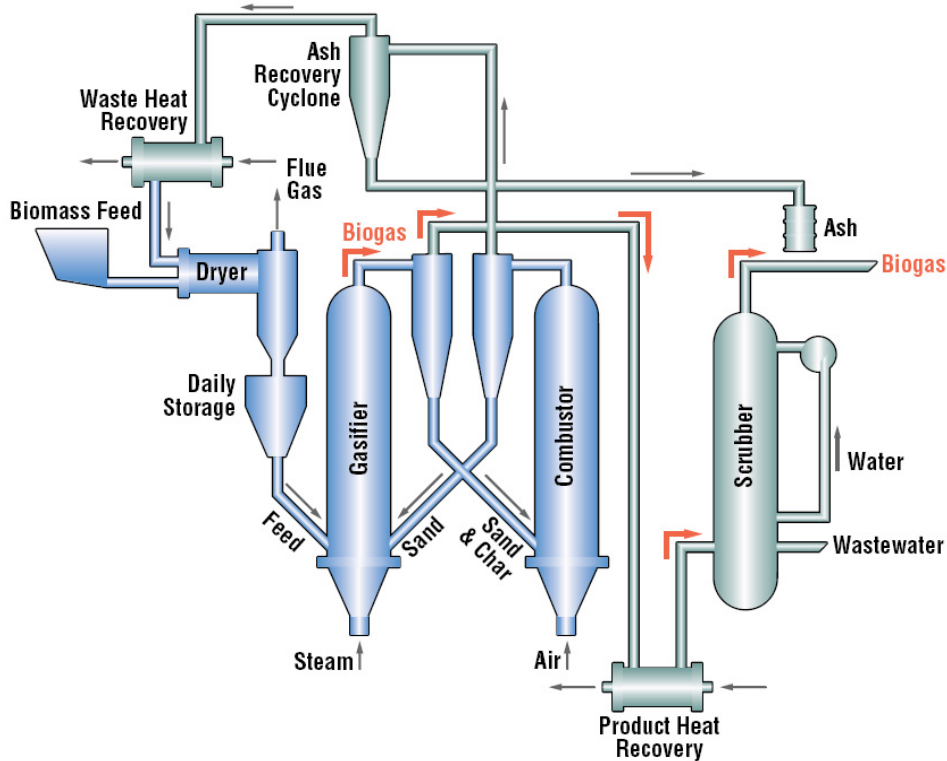

Figure 17. Illustration about the operating principle of the SilvaGas process (www.silvagas.com).

A number of improvements to process auxiliary systems like materials handling, solids separation, and product gas scrubbing had to be made. A novel hot-gas conditioning catalyst was also developed for tar destruction purposes. In 2002, after the completion of the DOE program and testing, the Vermont Gasifier Project was decommissioned.

The partners in the development of the process at the McNeil site were FERCO, Burlington Electric, Battelle, the US DOE, and the National Renewable Energy Laboratory (NREL) (www.nrel.gov).

4. Selected ongoing biomass gasification projects and processes

4.2.4 AER gasification by ZSW, Germany

Adsorption Enhanced Reforming (AER) is a concept, where chemical absorption of carbon dioxide is integrated to the gasification process. The work is currently performed in an EC-project called AER-gas II (www.aer-gas.de) under the coordination of ZSW.

The idea is to add catalytic absorbent material inside the reactor to transfer CO_2 from the gasification zone to the combustion zone causing a shift in the reaction equilibrium that leads to increase in the hydrogen concentration (see Figure 18).

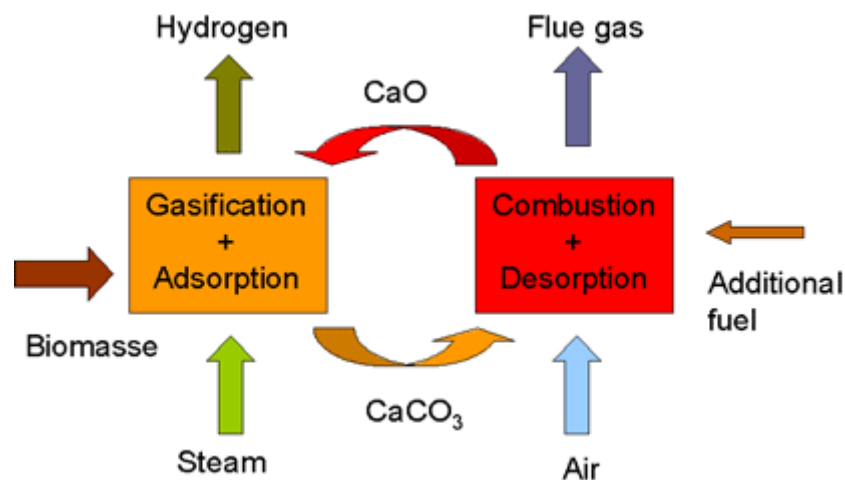

Figure 18. A diagram showing the operating principle of adsorption enhanced reforming (www.ficfb.at).

Several experimental tests have been executed in the past with TUW's 100 kW-scale laboratory gasifier with promising results. During 2008, experimental work was successfully upscaled to 8 MW, along the operation of the Güssing biomass CHP gasifier in AER-Gas mode for a short period of time. At the moment design work for a demonstration plant in Germany is ongoing.

4.3 Oxygen-blown entrained-flow gasification

4.3.1 CHOREN 3-stage gasification process

The Carbo-V Process (Figure 19) is a three-stage gasification process developed by CHOREN industries GmbH, including three sub-processes, namely low temperature gasification, high temperature gasification and endothermic entrained bed gasification.

Low temperature gasification – The first stage of the Carbo-V process is essentially a low temperature pyrolysis process that uses biomass with a moisture content of 15–20 %. The biomass is fed into the gasifier and carbonised with air or oxygen at

4. Selected ongoing biomass gasification projects and processes

temperatures between 400 and 500 °C, which breaks biomass down into solid carbon (char) and tar-laden gas (volatile parts).

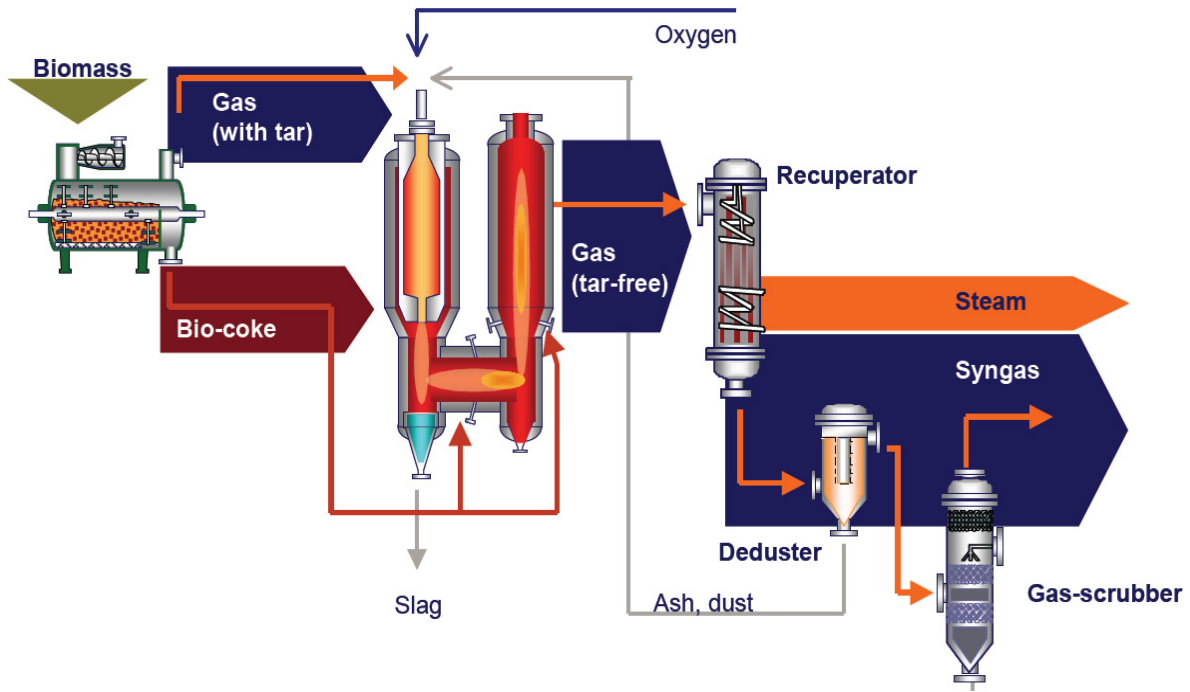

Figure 19. An illustration of the CHOREN Carbo-V gasification process.

High temperature gasification – The tar-laden gas from the first phase is then fed into the high temperature gasifier where it is oxidised using air and/or oxygen. The objective of this phase is to thermally crack the hydrocarbons of the gas by partial oxidation. The operating temperature is above the ash melting point of the fuel.

Entrained bed gasification – The char from the first stage is now pulverized and fed into the hot gasification zone. The pulverized fuel reacts endothermically with the gasification medium and produces raw synthesis gas. Once treated in appropriate manner, this combustible gas mixture can be used for the generation of power, heat or transportation liquids.

4.3.2 Beta plant, CHOREN

The CHOREN Beta plant at Freiberg, Germany is a demonstration site for the Carbo-V biomass-to-liquids process. The aim of the facility is to demonstrate the production of 2nd generation biofuels via thermal gasification of biomass. The operating principle of the Carbo-V gasifier has been discussed in the previous chapter.

Mechanical completion of the Beta plant was announced in April 2008, but information about the start-up had not been released by fall 2008. In parallel with the

4. Selected ongoing biomass gasification projects and processes

commissioning of the Beta plant, it has been announced that basic engineering work for a larger Sigma plant is underway. (www.choren.com.)

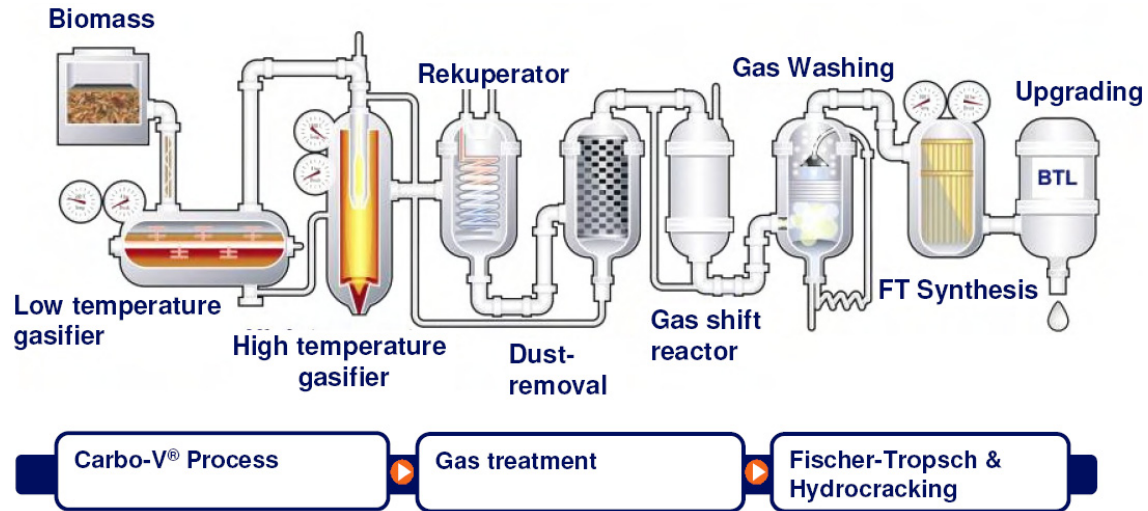

Figure 20. An illustration of the CHOREN Beta plant process (www.choren.com).

The 45 MW_{th} Beta plant uses woodchips with moisture content between 15–20 % for the production of Fischer-Tropsch liquids. The raw synthesis gas leaving the gasifier is first cooled and filtered for the WGS reaction, where the H₂/CO ratio is shifted to better fit the requirements of FT synthesis. After the WGS step, gas is dried and carbon dioxide captured together with ultra cleaning step. (Schulze 2008.)

Table 3. Major components of the CHOREN Beta plant (Schulze 2008).

Location	Conveyors	Heat exchangers	Pumps	Compressors and blowers	Reactors, vessels and others
Biomass logistics, syngas production and cleaning	93	31	62	35	363
FT synthesis, upgrading and ancillary systems	-	73	60	18	181

Listing the major components of a plant gives an idea of the engineering challenges related to BTL demonstrations: The Beta plant has 916 main components out of which 584 are related to the biomass logistics, syngas production and cleaning. The remaining 332 components are related to the FT synthesis, upgrading and ancillary systems. A more detailed breakdown of the main components is presented in Table 3.

4.3.3 Chemrec black liquor gasification

The Chemrec Kraft Recovery is a process based on refractory-lined entrained flow gasifier, operating around 1 000 °C and 32 bar (see Figure 21). In the gasifier, black liquor is decomposed to melt droplets of sodium compounds and combustible gas mixture containing CO, H₂ and CO₂. (Waldheim 2008.)

Chemrec DP-1 Major Process Units

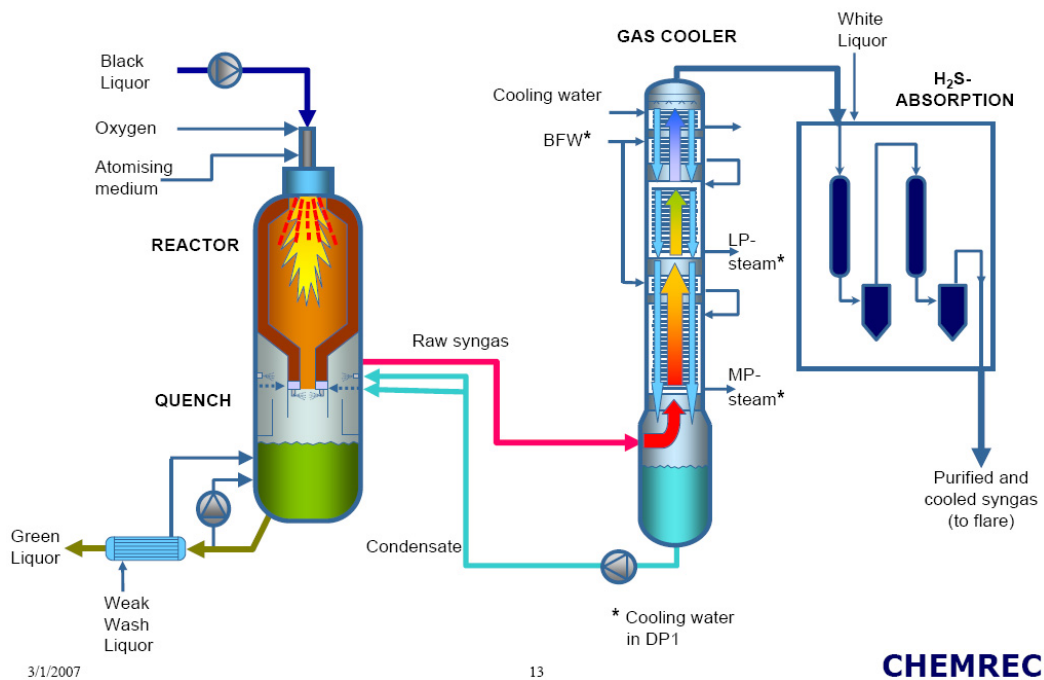

Figure 21. Illustration of the Chemrec DP-1 process (www.chemrec.se).

The gas mixture and the droplets are separated in a direct contact with a cooling liquid. The droplets dissolve into the liquid to form a green liquor solution. Gas leaving the reactor is first cooled down to produce medium and low-pressure steam and is simultaneously washed off from particulates. After H₂S removal, the gas is ready to be used as syngas.

4.3.4 DP-1, Piteå Sweden

Piteå (Sweden) is the demonstration site for the Chemrec's pressurized oxygen-blown gasification process. The aim of the development work is to gather data for design and operation of commercial scale gasifier for synthesis gas production purposes. The DP-1 is designed for gasification of about 20 dry tonnes/day of black liquor (3 MW_{thermal}) and to operate at about 30 bar and 1 000 °C.

4. Selected ongoing biomass gasification projects and processes

Chemrec's first black liquor gasification (BLG) program was executed during 2004–2006 comprising construction, start-up and operation of DP-1 plant in parallel with joint R&D program. The second phase (BLG II) was started in January 2007. BLG II comprises further R&D work together with operation of the DP-1 and should last another three years. The budget for the first three years was 11 M€ and for the second phase approximately 9 M€

The plant was inaugurated in the beginning of 2005 and from the spring of 2006 onwards the plant has produced syngas and green liquor with a high carbon conversion and only little amounts of char in the green liquor. Only limited tar-related fouling has been observed. As of April 2008, the plant had been operated 4 500 hours and reached full capacity at close to design pressure of 30 bars.

Chemrec is currently involved in a scale up of the gasification plant to a demonstration size (from 20 to 400–500 tonnes dry substance per day). Feasibility work is underway with methanol and/or DME being the most likely products corresponding to approximately 45 000–50 000 tonnes/year production capacity of methanol equivalents. (Waldheim 2008.)



Figure 22. A photograph of the pressurized development plant DP-1 at the Kappa Kraftline pulp mill, Piteå, Sweden (Waldheim 2008).

4. Selected ongoing biomass gasification projects and processes

4.3.5 FZK Bioliq, Lurgi

FZK Bioliq is a process developed by KIT, the Karlsruhe Institute of Technology, for the production of synthetic fuels from straw by decentralised fast pyrolysis and centralised entrained flow gasification.

The idea is to use pyrolysis to upgrade the energy density of straw from 2 GJ/m³ to the 25 GJ/m³ of pyrolysis oil. After the upgrading step it would be possible to transport the pyrolysis oil and coke with a radius of 250 km in order to fuel a large centralised gasification process with several regional pyrolysis plants. (www.fzk.de.)

The Lurgi centralized oxygen-blown, slagging entrained flow gasifier is designed to operate above the pressure level of downstream synthesis. This allows avoiding the expensive pressurization step for the intermediate syngas. The gasifier can use any pumpable feed that can be pneumatically atomized with oxygen and has over 10 MJ/kg heating value as a feestock. The energy efficiency of the biomass conversion to liquid fuels via syngas is about 40 %. (Cornitius 2009.)



Figure 23. A photograph of the FZK's Bioliq demonstration facility (www.fzk.de).

For process development purposes a 500 kg/h pyrolysis plant (2 MWth) was constructed to Karlsruhe (Figure 23) during 2006–2007. The operation was scheduled to start during 2008.

4. Selected ongoing biomass gasification projects and processes

4.3.6 MILENA gasifier, ECN

A renewed interest to SNG as energy carrier has recently surfaced in the Netherlands. For this reason, ECN has started to develop indirect gasification process with a high overall efficiency of biomass to SNG. The indirect (allothermal) gasification process MILENA, depicted in Figure 24, is quite similar to the FERCO/Silvagás-concept with the exception of only one integrated reactor instead of two separate.

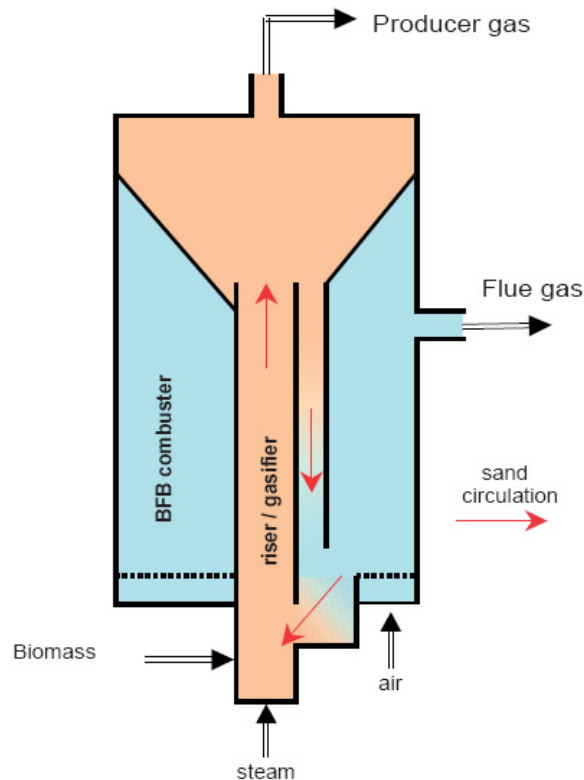

Figure 24. A cross section of the MILENA gasifier (www.milenatechnology.com).

Experimental results with a 25 kW_{th} laboratory-scale MILENA have shown that the gasifier can achieve high efficiency with a good fuel conversion. The product gas contains high amount of hydrocarbons, making the concept especially suitable for biomass-to-SNG applications.

The latest up-scaling activities related to the MILENA technology have been the start-up of an 800 kW pilot plant in September 2008. The gasifier will later be connected to ECN's OLGA process for tar removal. Plans for carrying out a 10 MW_{th} demonstration based on MILENA and OLGA technology are also underway. The target is to produce SNG directly to the existing gas network or to be used as transport fuel. (www.ecn.nl)

4. Selected ongoing biomass gasification projects and processes



Figure 25. A photograph taken during the construction of MILENA demonstration plant (www.milenatechnology.com).

4.4 Other technologies

4.4.1 BioMCN, the Netherlands

The Dutch company BioMCN intends to convert crude glycerine into green methanol. On the site in Delfzijl, Netherlands an existing methanol plant (formerly Methanor) with total capacity of 800 000 tons of methanol per year was reconstructed to enable the use of glycerine. Originally, the plant was based on catalytic steam reforming of natural gas to produce synthesis gas.

The crude glycerin is a byproduct from the biodiesel production (trans-esterification), and according to the Renewable Energy Directive the glycerine should be considered as a 2nd generation biofuel feedstock. In a first step glycerine is further purified and then converted into synthesis gas. The clean synthesis gas is then turned into methanol. Instead of producing methanol, an option would be to recover the hydrogen from the synthesis gas, i.e. producing renewable hydrogen.

The initial capacity of the process will be 200 000 tons of green methanol a year. The company has announced that the feasibility of the glycerine-to-methanol process has been demonstrated on a pilot plant scale in March 2008 and that a larger 200 000 t/a unit will come on stream during 2009. This would make BioMCN the first company in the world to produce high quality biomethanol from renewable resources on an industrial scale. (www.biomcn.eu.)

5. Conclusions

Demand for hydrogen is likely to increase in the future. This development is driven in the medium-term by tightening product specification requirements at oil refineries and in the longer-term by the possibility of hydrogen becoming an important energy carrier.

New and revolutionary production methods, capable of replacing the classical process routes, can not however be foreseen to emerge in the medium-term. Also the new hydrogen separation technologies, presently under development, seem to have only limited potential to reduce the production cost of hydrogen compared to commercially available technology. However, with rising prices of fossil fuels and locally depleting natural gas reserves, gasification route is likely to gain more ground as a credible production technology for hydrogen.

The global needs to cut down the CO₂ emissions can also make gasification of biomass an interesting possibility. Several biomass gasification processes are presently at demonstration phase, mostly aimed for the production of liquid transportation fuels. If and when this technology will be commercialized, it could easily be adopted to the production of hydrogen.

References

- Ackiewicz, M. 2009. Personal communication.
- Chemrec – Turning pulp mills into refineries, 2009. 10.2.2009 last update [Homepage of Chemrec], [Online]. Available: <http://www.chemrec.se> [2009, 02/12].
- Project update: The Vermont gasifier 2000. Available: <http://www.nrel.gov/docs/fy00osti/27983.pdf>.
- Silvagas webpage. Available: <http://www.silvagas.com/proj-vgp.htm> [2008, 11/14].
- Cornitius, T. 2009. Lurgi Building Second-Generation German Biofuels plant Using Novel Bioliq Technology, Zeus Syngas Refining Report edn, Zeus Development Corporation, Houston, Texas, USA.
- Dayton, D. 2002. A Review of the literature on Catalytic Biomass Tar Destruction, NREL, 1617 Cole Blvd. Golden, CO 80401-3393.
- Fagnäs, L., Brammer, J., Wilén, C., Lauer, M. & Verhoeff, F. 2008. Drying of biomass for 2nd generation synfuel production.
- Kunii, D. & Levenspiel, O. 1991. Fluidization Engineering
- Kurkela, E., Nieminen, M. & Simell, P. 2004. Development and Commercialisation of Biomass and Waste Gasification Technologies from Reliable and Robust Co-Firing Plants Towards Synthesis Gas Production and Advanced Power Cycles, Proceedings of the 2nd World Conference and Technology Exhibition on Biomass for Energy, Industry and Climate Protection ETA-Florence and WIP-Munich, Florence, Italy.
- McKeough, P. & Kurkela, E. 2008. Process evaluations and design studies in the UCG project 2004–2007. Espoo, VTT. 45 p. VTT Tiedotteita – Research Notes 2434. ISBN 978-951-38-7209-0; 978-951-38-7210-6. Available: <http://www.vtt.fi/inf/pdf/tiedotteet/2008/T2434.pdf>.
- Miller, C.L., Cicero, D.C. & Ackiewicz, M. 2008. Hydrogen from Coal Programm, External Draft, U.S. Department of Energy, Office of Fossil Energy, NREL.
- Milne, T.A., Elam, C.C. & Evans, R.J. 2001. Hydrogen from Biomass State of the Art and Research Challenges.
- More, A. 1997. Modern Production Technologies.
- Rauch, R. 2008. Personal communication.
- Schulze, O. 2008. Status und Fakten zur Beta-Anlage, Energetische Nutzung von Biomassen – Velen VIII, DGMK-Fachbereichstagung 14.–16. April 2008 in Velen/Westf.
- Waldheim, L. 2008. IEA Task 33: Country Report of Sweden.

This report briefly describes the principal process options and unit operations, along with their present state of development, suitable for the production of hydrogen from biomass via thermal gasification route. The report also attempts to describe a selection of major R&D projects that strive to commercialize gasification processes for the production of ultra clean synthesis gas from biomass. Although the main driver for these development efforts is currently the need for liquid transportation biofuels, same gasification and gas cleaning technology could also be used to generate synthesis gas for the production of green hydrogen.